

Series SS Solid Stainless Cylinders

*Pneumatic to 200 PSI
Hydraulic to 1000 PSI Non shock
3/4", 1 1/8", 1 1/2", 2" Bore*

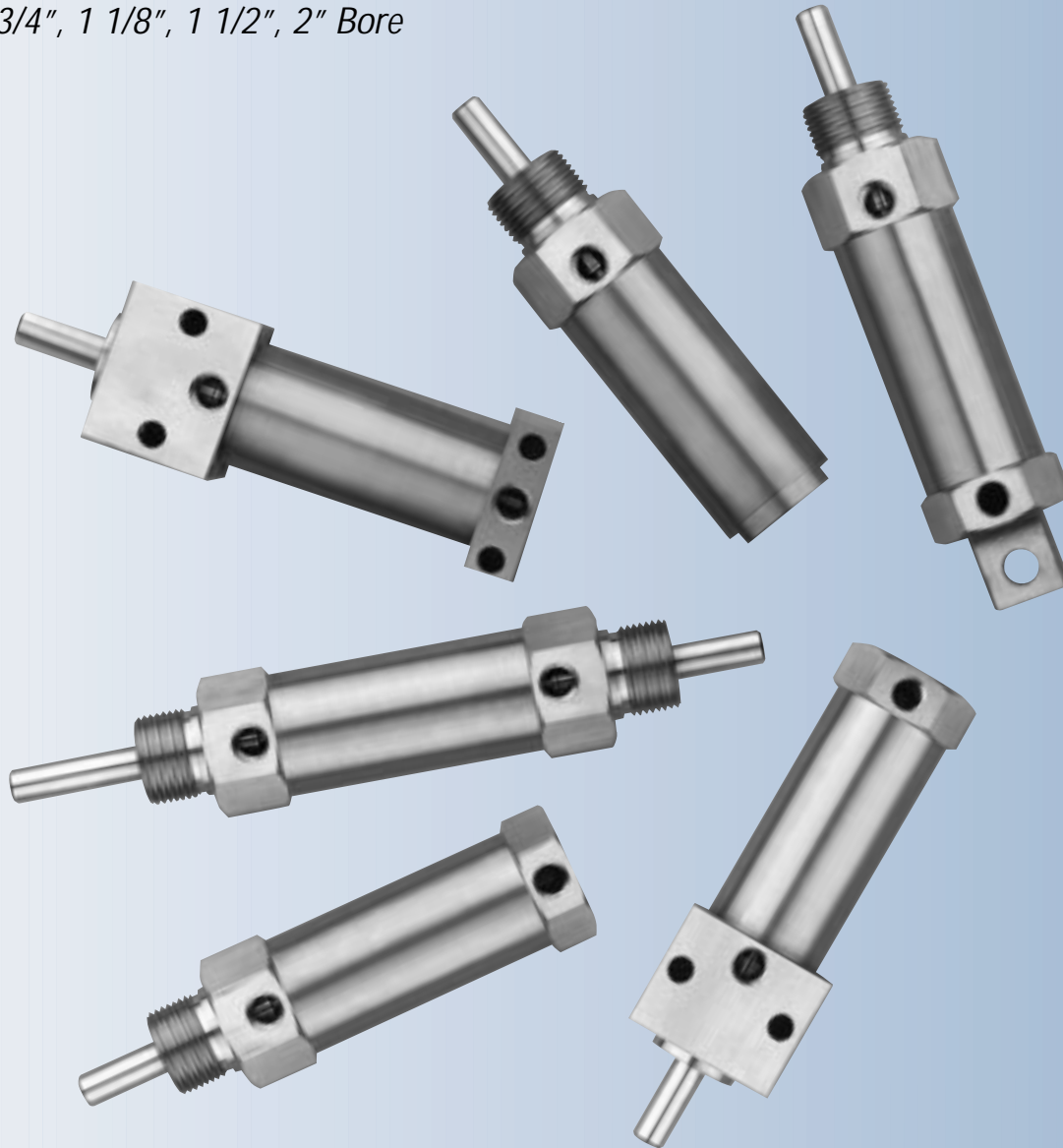

*To Help Brighten Your Corner of the World.
All exterior components 300 series stainless*

SS STAINLESS DESIGN FEATURES

Courtesy of Steven Engineering, Inc. • 230 Ryan Way, South San Francisco, CA, 94080-6370 • Main Office: (650) 588-9200 • Outside Local Area: (800) 258-9200 • www.stevenengineering.com

Piston rod is hard chrome plated type 303 stainless. Optional hollow piston rods available (hollow rod is not chrome plated)

End caps are machined from type 303 stainless steel.

Heavy duty urethane rod wipers seal out the environment. Other materials available.

Removable stainless retaining rings hold the seal and rod wiper in place.

Pneumatic Rod Seal is a "longlife" nitrile cup. Hydraulic Rod Seal is pressure energized and extra long wearing for improved stability

Extra long rod bearings of sintered bronze provide ample support and serve as an oil reservoir for pneumatic use. The bearing is inboard of the seal, away from the environment to ensure proper lubrication. Optional non metallic rod bearings available for chemically inert or severe applications

Tube is heavy 1/8 inch wall type 304 stainless steel and is precision honed to insure proper size, roundness, and finish for maximum cylinder life.

Brass piston silver brazed to the piston rod provides an almost indestructable joint. Optional solid stainless steel piston with teflon wearstrip available for chemically inert or clean applications.

Reduce noise and fatigue problems such as rod breakage with urethane shock pads. Pneumatic use only to 180° F.

Piston seals are extra long wearing pressure energized lip seals of the highest quality

O ring static tube seal

Optional wick provides teflon lube for non-lube service

Adjustable cushions to provide deceleration at the end of the stroke are available on most models above 3/4" bore

Magnetic piston available to operate Aurora stainless proximity switches



3/4" BORE SERIES SS STAINLESS

200 PSI MAX. AIR
1000 PSI MAX. HYD. Non shock

Courtesy of Steven Engineering, Inc. • 230 Ryan Way, South San Francisco, CA, 94080-6370 • Main Office: (650) 588-9200 • Outside Local Area: (800) 258-9200 • www.stevenengineering.com

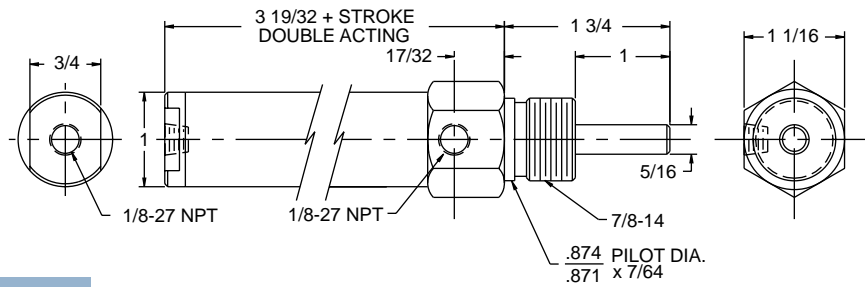

SS1

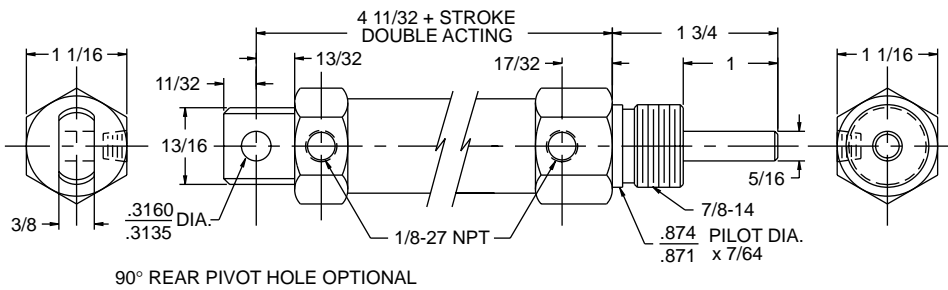

SS2

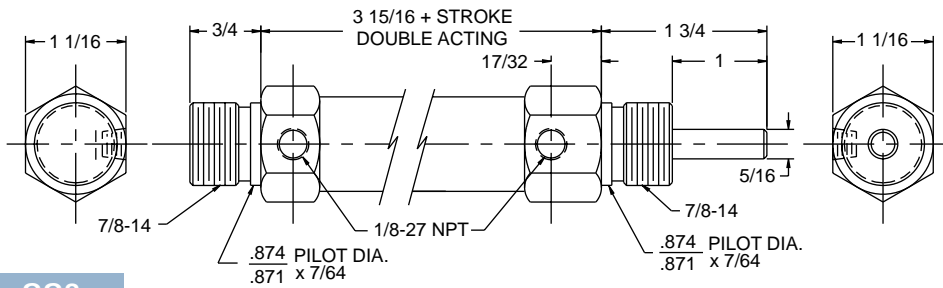

SS3

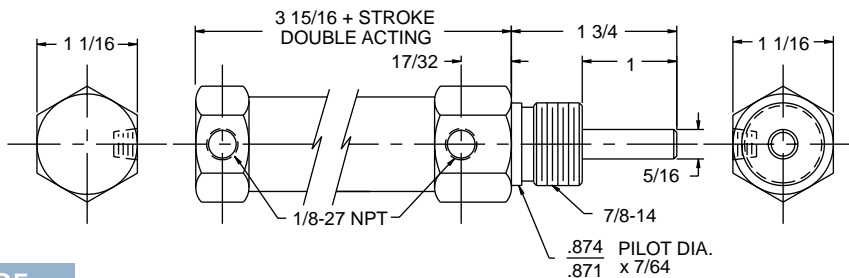

SS5

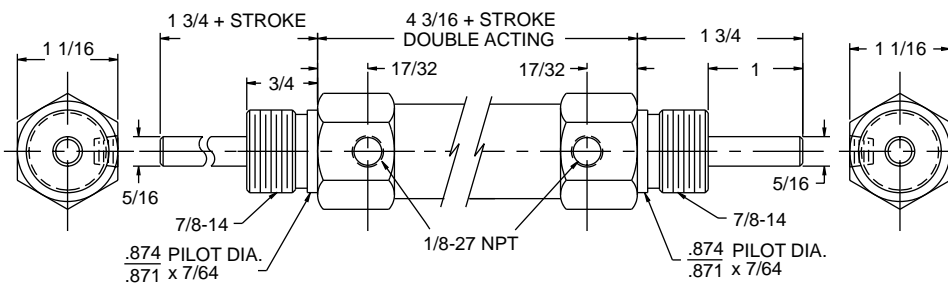

SS6

Single Acting Cylinders

Pneumatic only Adds to cylinder length

TYPE	STROKE	Add to cyl. O.A.L.	STROKE	Add to cyl. O.A.L.
Spring extend	0-1"	1"	Not available over 2" stroke	
Spring return	0-1"	1"	1 1/8"-2"	2"

Spring Force: Spring fully extended approx. 4#
Spring fully compressed approx. 12#

7/8 -14SS Nut Nose Mounting Nut

Not included with cylinder
Order Separately

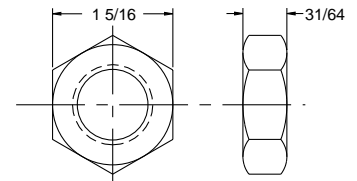

18-8 Stainless

SS-312

Rod Clevis
and Nut

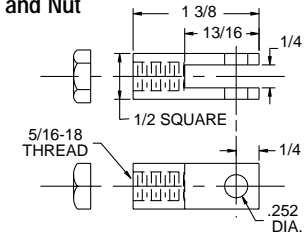

303 Stainless

SS-200

Clevis Pin Assembly

Used on SS-312 303 Stainless



*Suitable
for
Submerged
Service
with Reverse
Polypak Wiper*

SS Options

- Shock Pads
- Wrench Flats
- Viton Seals
- Non-lube Service
- Non-Metallic Rod Br'g
- Reverse Polypak Wiper
- Stainless Piston
- Magnetic Piston
- Hollow Piston Rod
- 90° Rear Clevis

Wrench Flats Optional

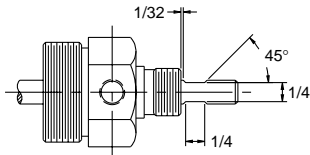

STAIN • LESS
(STAN'LIS) Adjective
1. Without blemish or stain: a stainless reputation

SS-40
St'd Clevis Brk't

Used on SS 2
Series 300 Stainless

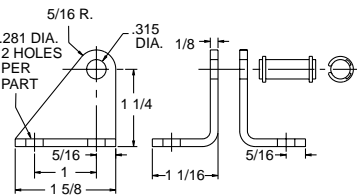

SSC-30
Low Profile Clevis Brk't

Used on SS 2
Series 303 Stainless

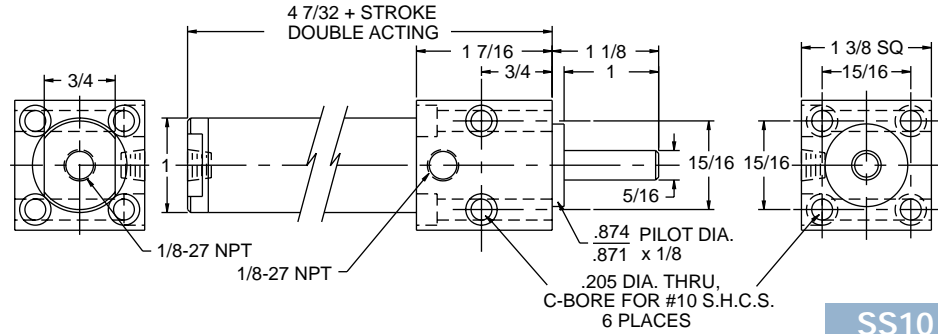
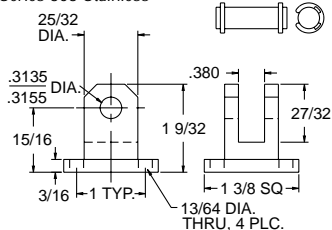

SS10

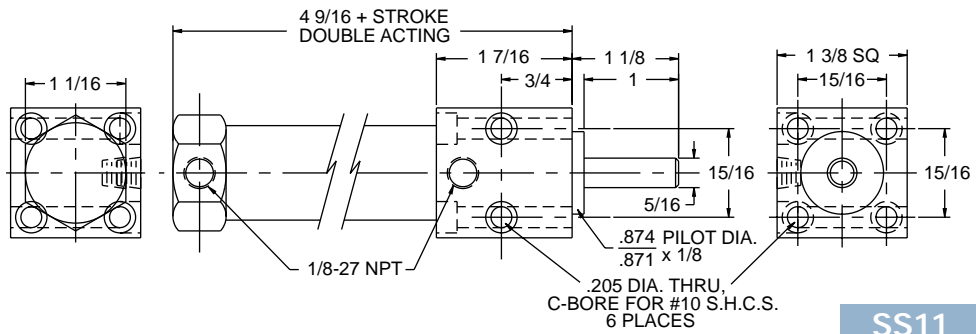

SS11

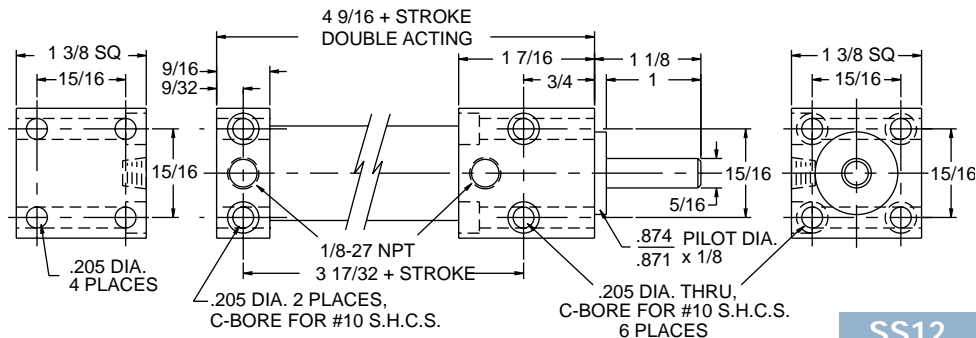

SS12

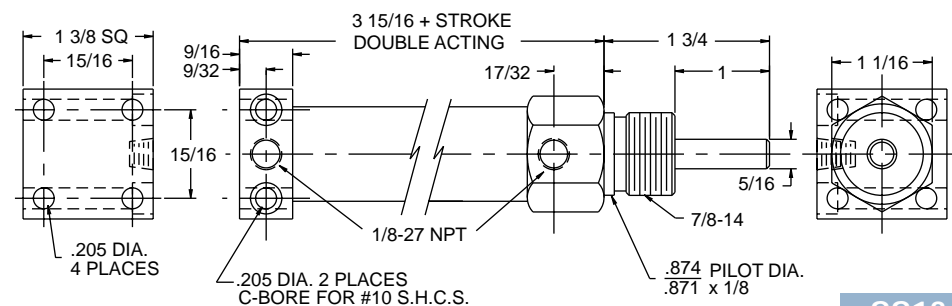

SS13

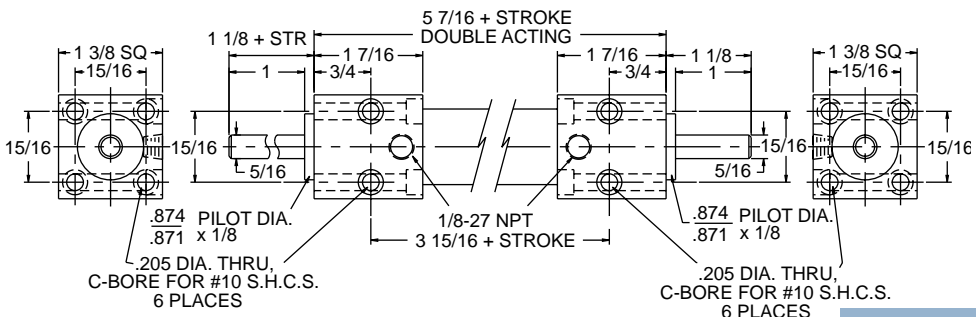

SS14

Series SS Solid Stainless

1 1/8" BORE SERIES SS STAINLESS

200 PSI MAX. AIR
1000 PSI MAX. HYD. Non shock

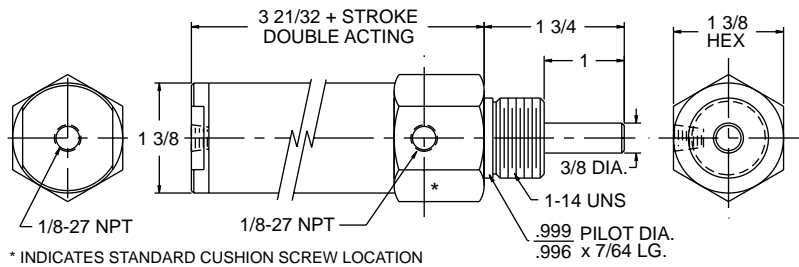

SS1

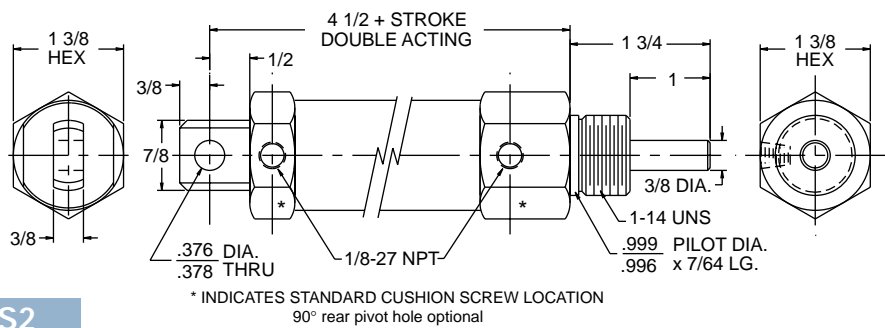

SS2

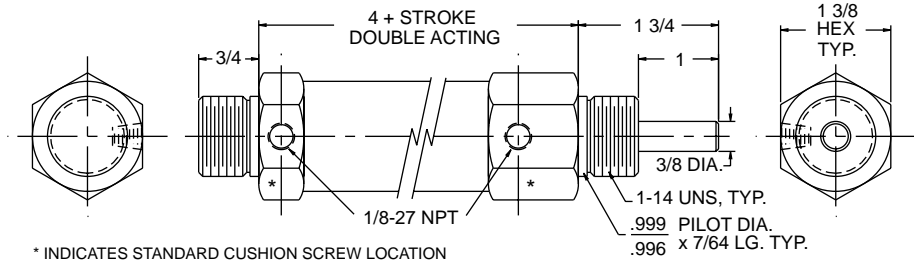

SS3

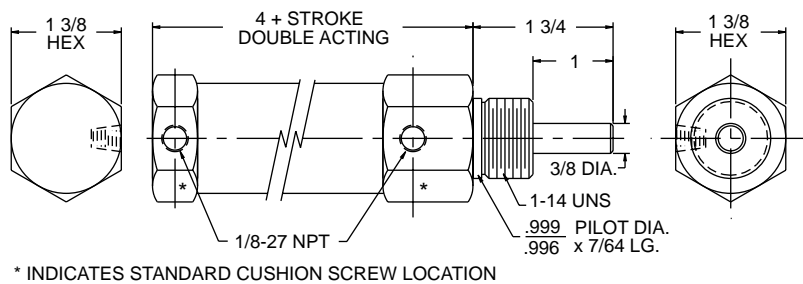

SS5

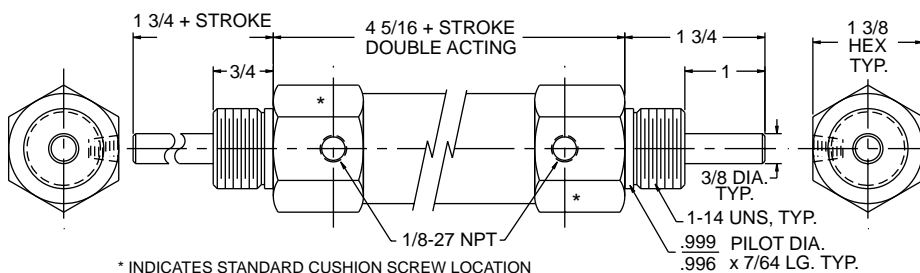

SS6

Single Acting Cylinders

Pneumatic only Adds to cylinder length

TYPE	STROKE	Add to cyl. O.A.L.	STROKE	Add to cyl. O.A.L.
Spring extend	0-2"	1 1/2"	Not available over 2" stroke	
Spring return	0-2"	1 1/2"	2 1/8"-4"	3"

Spring Force: Spring fully extended approx. 7#
Spring fully compressed approx. 22#

1 -14SS Nut Nose Mounting Nut

Not included with cylinder
Order Separately

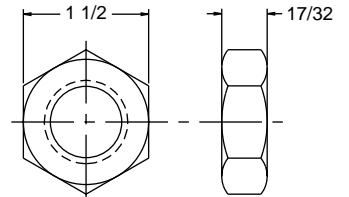

18-8 STAINLESS

SS-375

Rod Clevis
and Nut

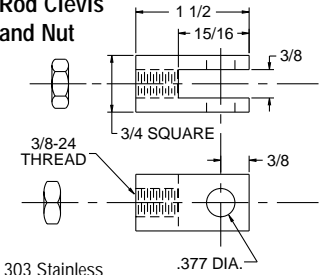

303 Stainless

SS-301

Clevis Pin Assembly

Used on SS-375

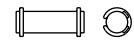

303 Stainless

**Conventional
Cylinder
Cost**

+ Warranty Repairs

+ Downtime

+ Liability

> Aurora Stainless

SOLID STAINLESS CYLINDERS IN 24 HOURS



SS Options

- Shock Pads
- Wrench Flats
- Viton Seals
- Non-lube Service
- Non-Metallic Rod Br'g
- Reverse Polypak Wiper
- Stainless Piston
- Magnetic Piston
- Hollow Piston Rod
- 90° Rear Clevis
- Adjustable Cushions

Wrench Flats Optional

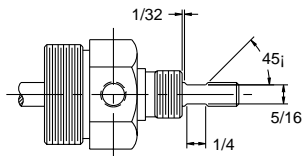

Series SS
Stainless have been field proven since 1983

SS-90

St'd Clevis Brk't
 Used on SS 2
 Series 300 Stainless

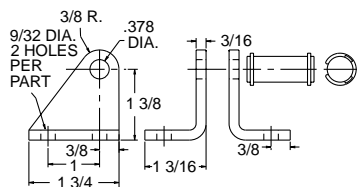

SSC-40

St'd Clevis Brk't
 Used on SS 2
 Series 303 Stainless

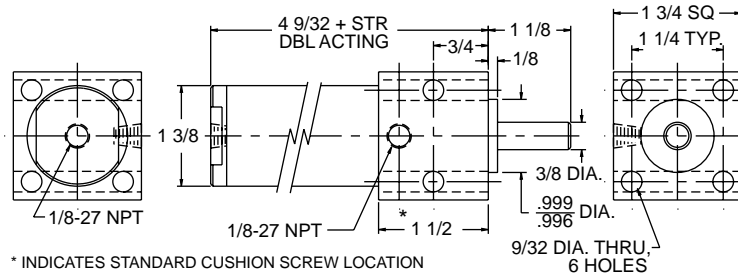
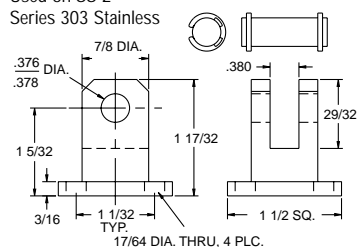

* INDICATES STANDARD CUSHION SCREW LOCATION

SS10

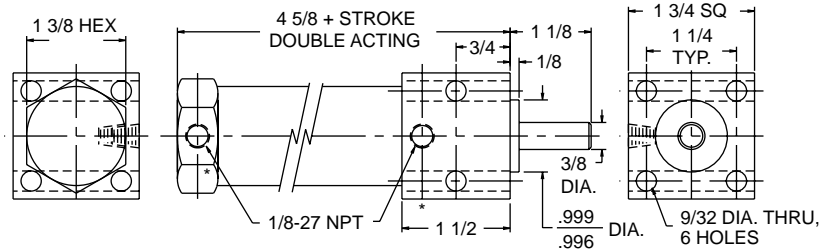

* INDICATES STANDARD CUSHION SCREW LOCATION

SS11

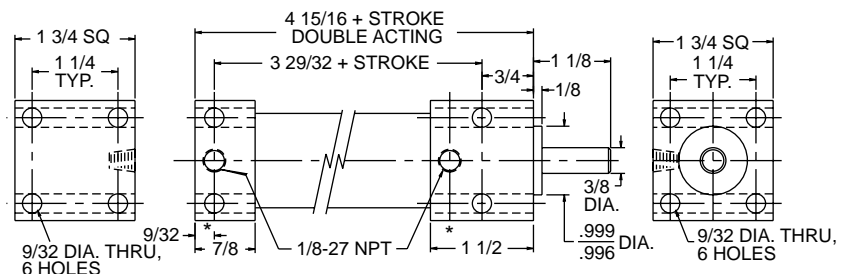

* INDICATES STANDARD CUSHION SCREW LOCATION

SS12

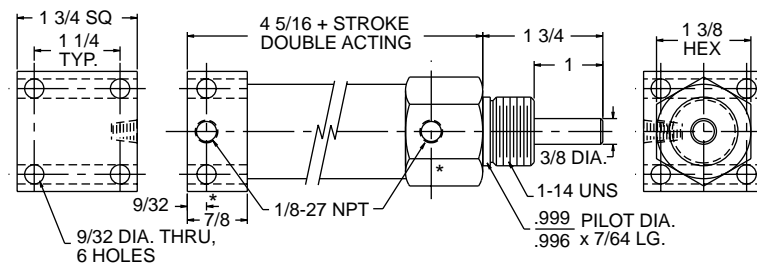

* INDICATES STANDARD CUSHION SCREW LOCATION

SS13

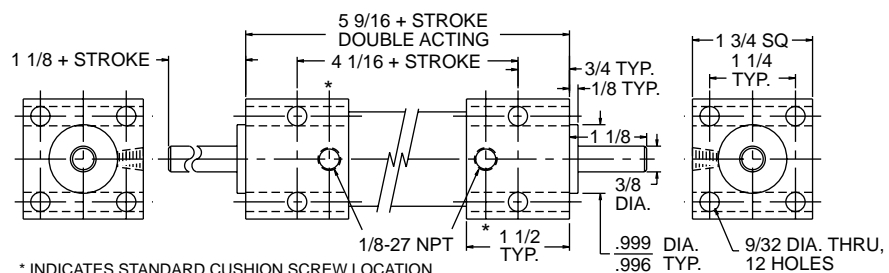

* INDICATES STANDARD CUSHION SCREW LOCATION

SS14

Series SS Solid Stainless

1 1/2" BORE SERIES SS STAINLESS

200 PSI MAX. AIR
1000 PSI MAX. HYD. Non shock

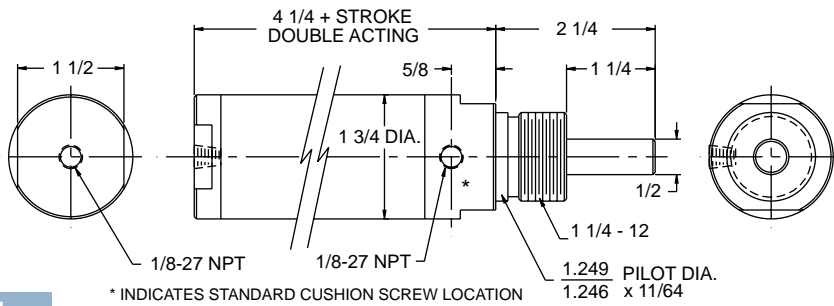

SS1

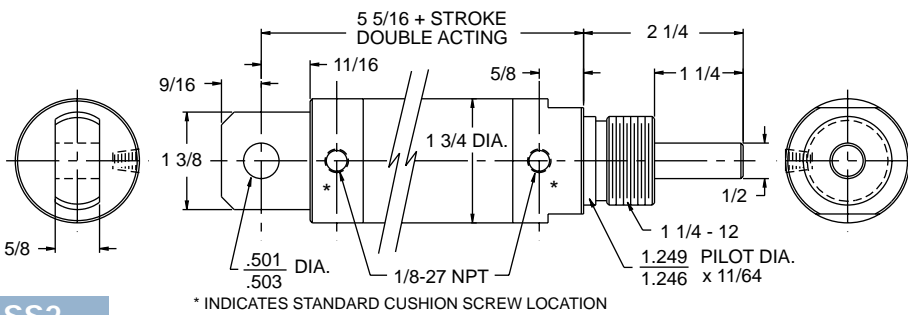

SS2

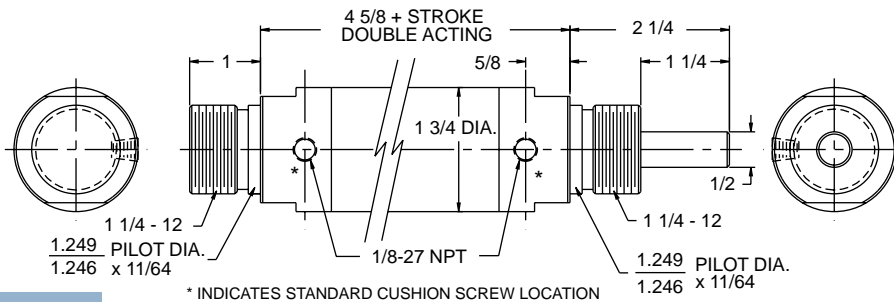

SS3

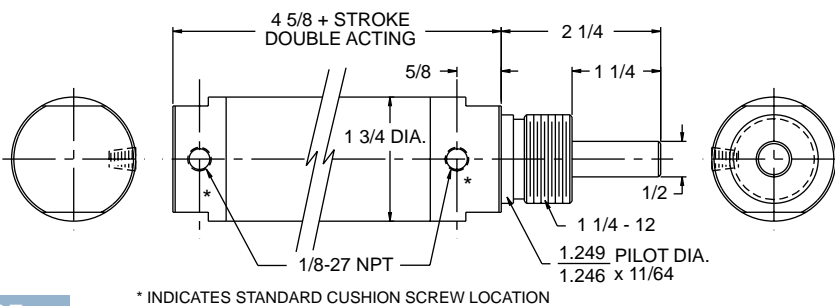

SS5

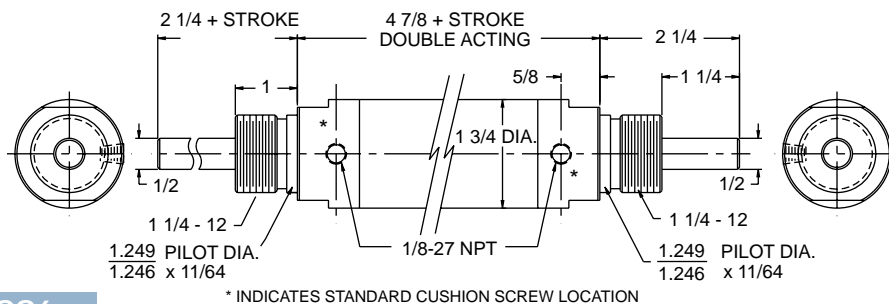

SS6

Single Acting Cylinders

Pneumatic only Adds to cylinder length

TYPE	STROKE	Add to cyl. O.A.L.	STROKE	Add to cyl. O.A.L.
Spring extend	0-2"	1 1/2"	2 1/8"-4"	3"
Spring return	0-2"	1 1/2"	2 1/8"-4"	3"

Spring Force: Spring fully extended approx. 15#
Spring fully compressed approx. 50#

1 1/4 - 12SS Nut Nose Mounting Nut

Not included with cylinder
Order Separately

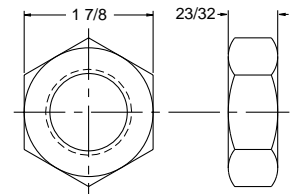

18-8 Stainless

SS-500

Rod Clevis and Nut

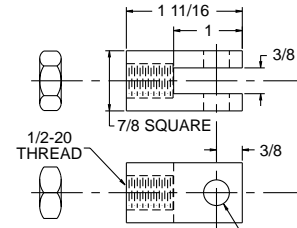

303 Stainless

SS-501

Clevis Pin Assembly

Used on SS-500



303 Stainless

*We'll Bill You for the
Cylinders. . .*

*but Our Experience is
Free*

630 851 4515

2" BORE SERIES SS STAINLESS

200 PSI MAX. AIR
1000 PSI MAX. HYD. Non shock

Courtesy of Steven Engineering, Inc. • 230 Ryan Way, South San Francisco, CA, 94080-6370 • Main Office: (650) 588-9200 • Outside Local Area: (800) 258-9200 • www.stevenengineering.com

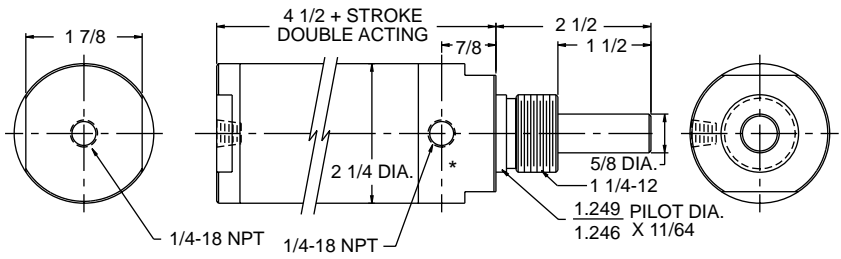

SS1

* INDICATES STANDARD CUSHION SCREW LOCATION

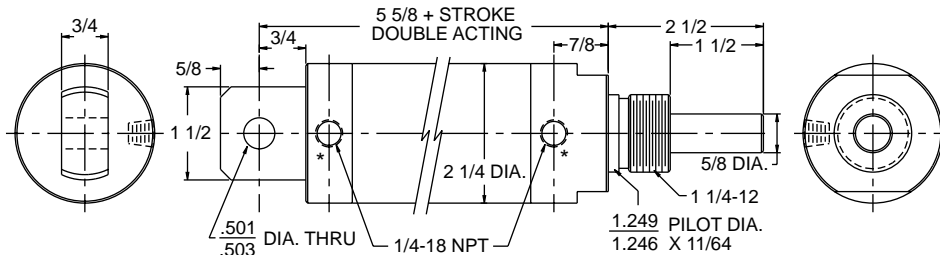

SS2

90° REAR PIVOT HOLE OPTIONAL

* INDICATES STANDARD CUSHION SCREW LOCATION

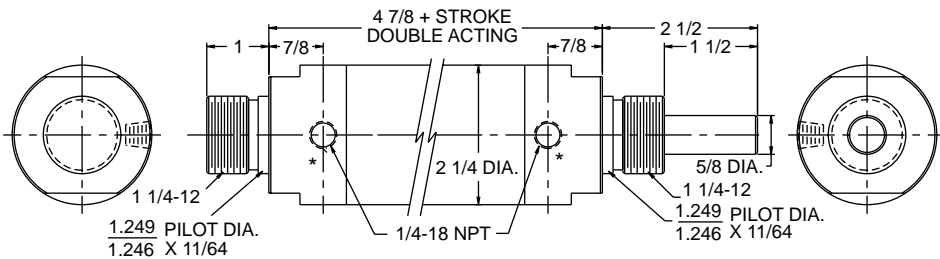

SS3

* INDICATES STANDARD CUSHION SCREW LOCATION

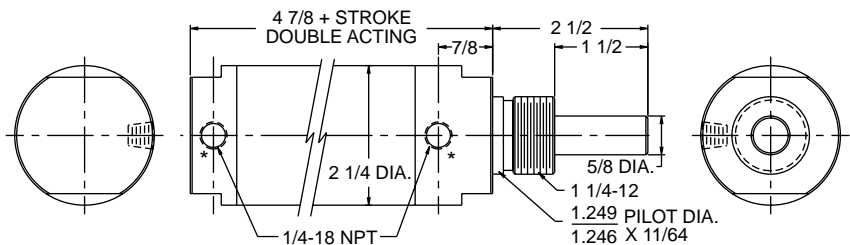

SS5

* INDICATES STANDARD CUSHION SCREW LOCATION

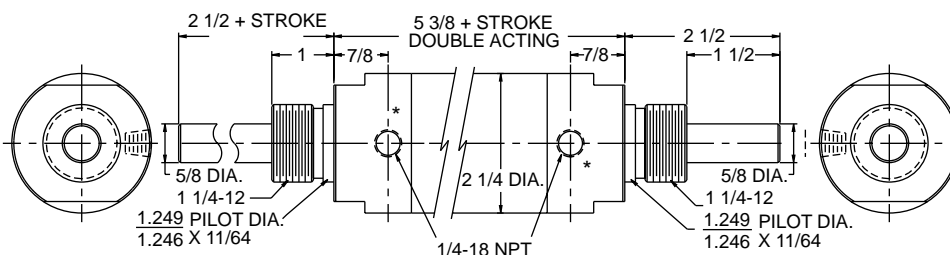

SS6

* INDICATES STANDARD CUSHION SCREW LOCATION

Single Acting Cylinders

Pneumatic only Adds to cylinder length

TYPE	STROKE	Add to cyl. O.A.L.	STROKE	Add to cyl. O.A.L.
Spring extend	0-2"	1 1/2"	2 1/8"-4"	3"
Spring return	0-2"	1 1/2"	2 1/8"-4"	3"

Spring Force: Spring fully extended approx. 20#
Spring fully compressed approx. 75#

1 1/4 -12SS Nut

Nose Mounting Nut

Not included with cylinder
Order Separately

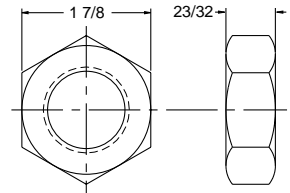

18-8 Stainless

SS-625

Rod Clevis and Nut
303 Stainless

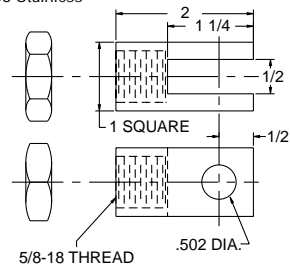

SS-601

Clevis Pin Assembly

Used on SS-625 303 Stainless

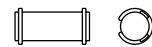

**Make the
Best Choice**

1 630 851 4515

ask for
Technical Support

SOLID STAINLESS CYLINDERS IN 24 HOURS



SS Options

- Shock Pads
- Wrench Flats
- Viton Seals
- Non-lube Service
- Non-Metallic Rod Br'g
- Reverse Polypak Wiper
- Stainless Piston
- Magnetic Piston
- 90° Rear Clevis
- Adjustable Cushions

Wrench Flats Optional

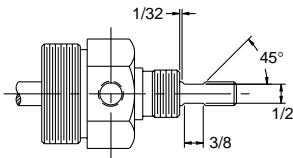

UNIQUE APPLICATIONS SOMETIMES REQUIRE UNIQUE CYLINDERS

See our custom design capabilities on page 87

SS-100

St'd Clevis Br'k't
Used on SS 2
Series 300 Stainless

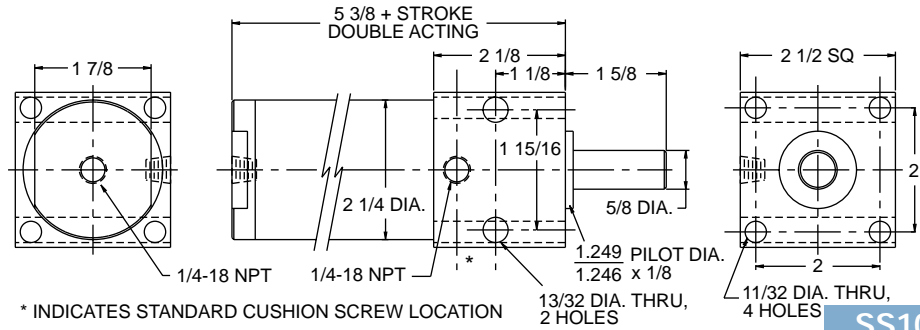
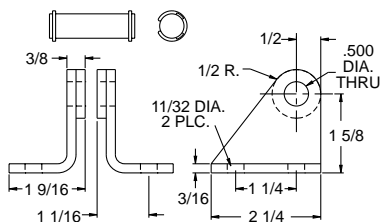

SS10

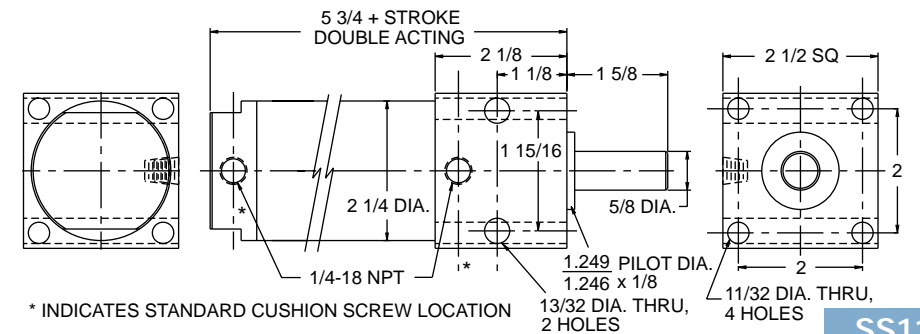

SS11

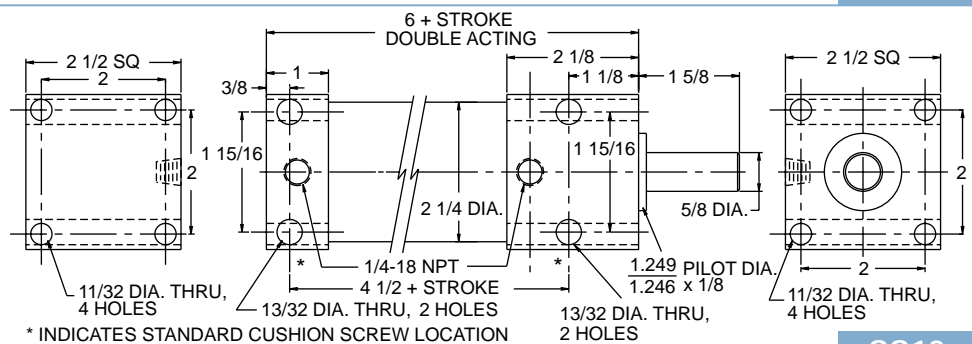

SS12

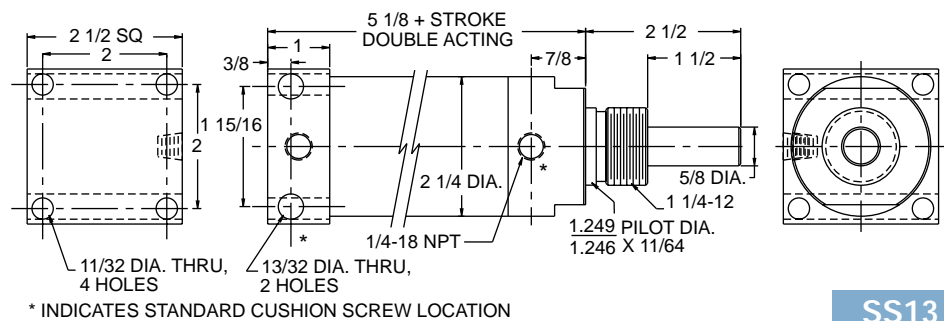

SS13

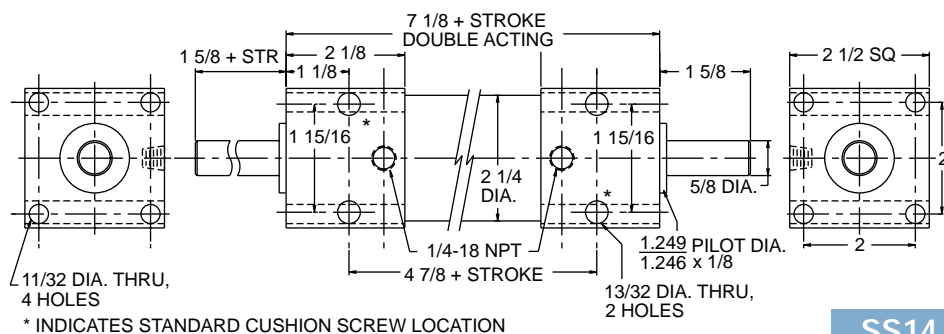

SS14

Series SS Solid Stainless

ORDERING PROCEDURE - Series SS Stainless

Select code numbers/letters (**bold type**) from each of the six boxes below - then select options desired from the table below. List codes in the same sequence as shown.

Bore	Code
3/4"	07
1 1/8"	11
1 1/2"	15
2"	20

Type	Code
Single Acting Spring return*	A
Single Acting Spring extend*	B
Double acting	C

*Adds to cyl. length
If double rod end model is to be single acting, select **A**

Service	Code
Pneumatic	E
Hydraulic	G



Mounting Style/Code	
SS 1	SS 10
SS 2	SS 11
SS 3	SS 12
SS 5	SS 13
SS 6	SS 14

Stroke
Code is stroke in total 1/8" increments
Example: 1" stroke = 8
2 1/4" stroke = 18
Stocked in 1/2" increments as follows:
3/4" bore to 6" 1 1/8" bore to 8"
1 1/2" bore to 10" 2" bore to 12"

Piston Rod Codes		
Bore	Thread	Code
All	Plain rod No thread	0
.750	5/16-18 x 3/4	3
.750	5/16-24 x 3/4	4
1.125	3/8-16 x 3/4	5
1.125	3/8-24 x 3/4	6
1.500	1/2-13 x 1	7
1.500	1/2-20 x 1	8
2.000	5/8-11 x 1 1/4	11
2.000	5/8-18 x 1 1/4	12

SS 6, 14 Double rod models will have same rod thread both ends

Option	Description	Code
Extra rod extension	Specify code letter J followed by the extra length as a two place decimal. Example: J.50 = 1/2" extra J1.25 = 1 1/4" extra SS6, 14 double rod cylinders with extra extension cannot be ordered by a standard part number - consult factory for a special part number.	J
Wrench flats	Specify if required If specified will be added to both ends of SS6, 14 double rod cylinders	K
Shock pads	Double acting cylinders only — must be added to both ends Adds 1/2" to length — pneumatic use only to 180°F	N
Non-lube service	Pneumatic only — Not available with magnetic piston or solid stainless piston	P
Viton seals	Standard seals are nitrile and urethane +10 to +180°F For service -10 to +400°F specify viton	R
Reverse polypak rod wiper	More effective at keeping liquids and gases out of the cylinder	S
Clevis 90° to st'd	SS 2 only	T
Stainless piston	303 Stainless with teflon wear strip Not available with magnet, non lube, or cushion options	V
Magnetic piston	Adds 1/2" to length on 3/4" bore only Not available with Non-lube or stainless piston options	W
Hollow piston rod	Available in 5/16 dia.rod – thru hole .135" Available in 3/8 dia.rod – thru hole .248" Available in 1/2 dia.rod – thru hole .313" Rod is plain 304 stainless - no chrome plating	X
Non - metallic rod bushings	Fiberglass backed teflon	Y
Adjustable Cushions	Not Available on: 3/4" bore cylinders Rear port caps (SS1, 10) Solid stainless piston Cylinders with shock pads	Cushion head end only AA Cushion cap end only BB Cushion both ends CC

Part No. Example:

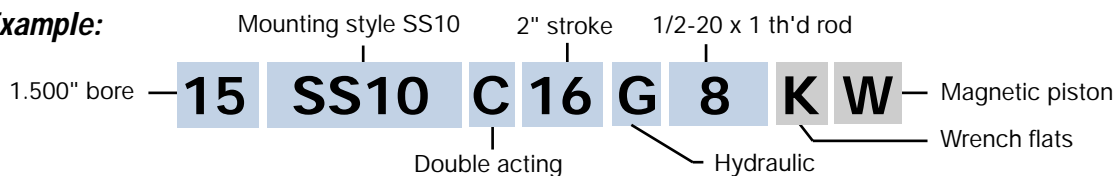

Series SS Service Parts

When ordering any repair part please provide the part number and description shown below along with the serial number and part number of the cylinder being serviced.

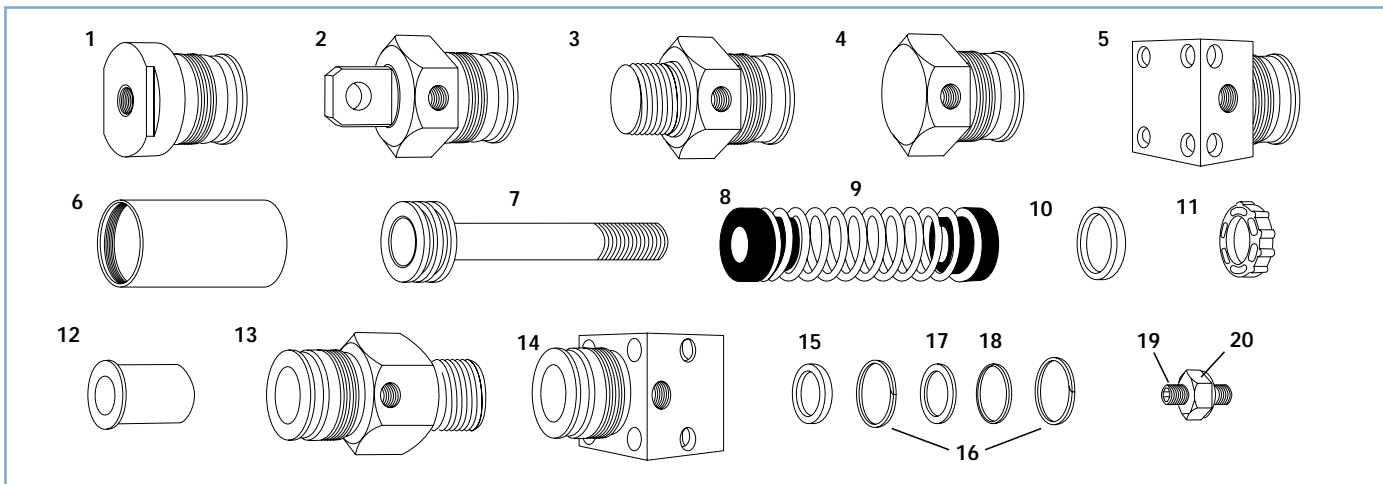

Key	Description	3/4 Bore	1 1/8 Bore	1 1/2 Bore	2 Bore
	Seal kit - Pneumatic, Nitrile Add suffix NL for Non-lube Add suffix REV for Reverse Polypak Wiper Add suffix W with Stainless Piston	SS 2207 PB	SS 2211 PB	SS 2215 PB	SS 2220 PB
	Seal kit - Pneumatic, Viton Add suffix NL for Non-lube Add suffix REV for Reverse Polypak Wiper Add suffix W with Stainless Piston	SS 2207 PV	SS 2211 PV	SS 2215 PV	SS 2220 PV
	Seal kit - Hydraulic, Urethane Add suffix REV for Reverse Polypak Wiper Add suffix W with Stainless Piston	SS 2207 HU	SS 2211 HU	SS 2215 HU	SS 2220 HU
	Seal kit - Hydraulic, Viton Add suffix REV for Reverse Polypak Wiper Add suffix W with Stainless Piston	SS 2207 HV	SS 2211 HV	SS 2215 HV	SS 2220 HV
1	Rear port cap	SS 1007	SS 1011	SS 1015	SS 1020
2	Rear pivot cap Add suffix C for adjustable cushion	SS 1107	SS 1111	SS 1115	SS 1120
2	90° Rear pivot cap Add suffix C for adjustable cushion	SS 110790	SS 111190	SS 111590	SS 112090
3	Rear stud cap Add suffix C for adjustable cushion	SS 1207	SS 1211	SS 1215	SS 1220
4	Side port cap Add suffix C for adjustable cushion	SS 1307	SS 1311	SS 1315	SS 1320
5	Square cap Add suffix C for adjustable cushion	SS 1507	SS 1511	SS 1515	SS 15 20
6	Tube	part No. is T followed by the complete cylinder part number			
7	Piston rod assembly	part No. is PR followed by the complete cylinder part number			
8	Spring guide Pair	SS 2007	SS 2011	SS 2015	SS 2020
9	Spring	SS 2107	SS 2111	SS 2115	SS 2120
10	Magnet 1 or 2 as necessary	SS 3207	SS 3211	SS 3215	SS 3220
11	Shock pad	75MSP	11MSP	15MSP	2MSP
12	Rod bearing Add suffix DU for non-metallic		SS 0211	SS 0215	SS 0220
13	Head w/ Bronze br'g Add suffix C for adjustable cushion	SS 0107	SS 0111	SS 0115	SS 0120
13	Head w/ Non-metallic br'g Add suffix C for adjustable cushion	SS 0107 DU	SS 0111 DU	SS 0115 DU	SS 0120 DU
14	Head w/ Bronze br'g Add suffix C for adjustable cushion	SS 1407	SS 1411	SS 1415	SS 1420
14	Head w/ Non-metallic br'g Add suffix C for adjustable cushion	SS 1407 DU	SS 1411 DU	SS 1415 DU	SS 1420 DU
15	Rod seal retaining washer	SS 0507	SS 0511	SS 0515	SS 0520
16	Rod seal/Rod wiper snap ring	SS 0607	SS 0611	SS 0615	SS 0620
17	Rod wiper inside retaining washer Add suffix REV for Reverse Polypak Wiper	SS 0307	SS 0311	SS 0315	SS 0320
18	Rod wiper outside retaining washer Add suffix REV for Reverse Polypak Wiper	SS 0407	SS 0411	SS 0415	SS 0420
19	Cushion screw 3/4" long		SS 2611	SS 2615	
19	Cushion screw 7/8" long		SS 2611L	SS 2615L	SS 2620L
20	Cushion screw locknut		SS 2711	SS 2715	SS 2720