

Infrared Products

Single Fiber Duplex Modules

HOD2236-111/BBA

HOD4090-111/BBA

FEATURES

- Full duplex over single fiber
- DC to 160 MHz link bandwidth
- Link budgets of 2 km [1.24 miles] or greater
- 40 dB isolation
- Low profile ST housing
- Other options available
- VCSEL is Class 1 eye safe

APPLICATIONS

- Full duplex data transmission
- Multiplexing two signals to a single fiber
- LED coupled power measurements and reflected power measurements (depending upon the configuration of the duplex module)

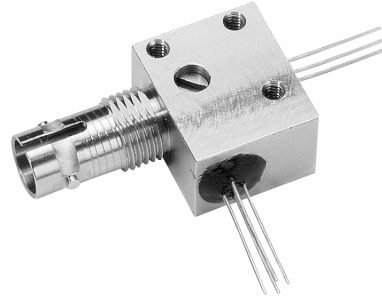

A pair of Honeywell HODXXX-XXX/BBA series of dual wavelength fiber duplex modules allows full duplex communication over a single fiber link. They may also be used where a dual fiber solution is neither possible nor economical. Alternatively, one duplex module may be used to double the capacity of an existing system.

Each duplex module consists of one on-axis port and one off-axis port, each configured with the appropriate devices. These devices are coupled to the single fiber via integral lenses and a 3 dB wavelength differentiating mirror within the duplex module body. In this configuration, two duplex modules can communicate in opposing directions simultaneously and independently of each other. Depending upon the receiver circuitry used, links of 2 km [1.24 miles] or greater are possible.

The following catalog listings indicate the two devices used in each duplex module.

- HOD2236-111/BBA:
 - 1300 nm multimode laser
 - 850 nm PIN diode
- HOD4090-111/BBA (corresponding duplex module):
 - 850 nm VCSEL (Vertical Cavity Emitting Surface Laser)
 - 1300 nm PIN diode

Other options are available on request. These include two LEDs or lasers in one duplex module for single fiber multiplexing, PIN+Preamp receivers (P+P) or any other preferred devices. Housing options include SC and ST optical ports or a high profile housing for mounting duplex modules side by side. Future connectors will likely include SMA, FC, LC and E2000. See the catalog listing numbering scheme on the back page for complete list of available configurations.

⚠ WARNING

MISUSE OF DOCUMENTATION

- The information presented in this product sheet (or catalog) is for reference only. DO NOT USE this document as product installation information.
- Complete installation, operation and maintenance information is provided in the instructions supplied with each product.

Failure to comply with these instructions could result in death or serious injury.

⚠ WARNING

PERSONAL INJURY

- DO NOT USE these products as safety or emergency stop devices, or in any other application where failure of the product could result in personal injury.

Failure to comply with these instructions could result in death or serious injury.

Infrared Products

Single Fiber Duplex Modules

HOD2236-111/BBA

HOD4090-111/BBA

ELECTRO-OPTICAL CHARACTERISTICS FOR THE HOD2236-111/BBA

Absolute Maximum Ratings (25 °C unless otherwise noted)

Continuous Forward Current	150 mA
Lead Solder Temperature	260 °C [500 °F], 10 sec
Operating Temperature	0 °C to 70 °C (32 °F to 158 °F)
Storage Temperature	-40°C to 85 °C (-40 °F to 185 °F)

CAUTION

STRESS DAMAGE

Functional operation of the device at or above "Absolute Maximum Ratings" for extended periods of time may affect reliability.

Failure to comply with these instructions may result in product damage.

Transmit: 1300 nm Laser (All tests made at 25 °C unless otherwise specified.)

Parameter	Symbol	Min.	Typ.	Max.	Units	Test Conditions
Fiber Coupled Power	P_{OC}	40 -14	65 -12	100 -10	μ W dBm	$I_F=17$ mA 50/125 μ m fiber
Laser Diode Reverse Voltage	V_{RLD}			2.0	V	
Photo Diode Reverse Voltage	V_{RPD}			10	V	
Photo Diode Forward Current	V_{FPD}			1	mA	
Slope Efficiency	SE	0.3	0.35		mW/mA	CW, $P_o=5$ mW
Threshold Current	I_{TH}		12	20	mA	CW, $P_o=5$ mW
Peak Wavelength	λ_p	1290	1310	1330	nm	CW, $P_o=5$ mW
Spectral Bandwidth	$\Delta\lambda$		2	5	nm	CW, $P_o=5$ mW
Forward Voltage	V_F		1.2	1.5	V	CW, $P_o=5$ mW
Response Time	t_r/t_f			0.5	ns	$I_{BIAS}=I_{TH}$, 10%-90%
Photo Diode Monitor Current	I_m	100			μ A	CW, $P_o=5$ mW, $V_{RPD}=2$ V
Photo Diode Dark Current	I_{DARK}			0.1	μ A	$V_{RLD}=5$ V
Photo Diode Capacitance	C		6	15	pF	$V_{RLD}=5$ V, $f=1$ MHz

Receive: 850 nm PIN Diode (All tests made at 25 °C unless otherwise specified.)

Parameter	Symbol	Min.	Typ.	Max.	Units	Test Conditions
Flux Responsivity	R	0.2	0.3		A/W	$\lambda=850$ nm
Dark Current	I_D		0.05	1.5	nA	$V_R=30$ V
Reverse Voltage	BVR			50	V	
Response Time						
10%-90%	t_r		1.2	3	ns	$V_R=3.5$ V
90%-10%	t_f		1.2	3		
Capacitance	C		1.5		pF	$V_R=5$ V

Infrared Products

Single Fiber Duplex Modules

HOD2236-111/BBA
HOD4090-111/BBA

CAUTION

PRODUCT DAMAGE DUE TO ESD

Ensure normal ESD (Electrostatic Discharge) precautions are followed when handling this product.

Failure to comply with these instructions may result in product damage.

HOD2236-111/BBA Duplex Module

Mounting and Dimensional Drawing (for reference only mm[in])

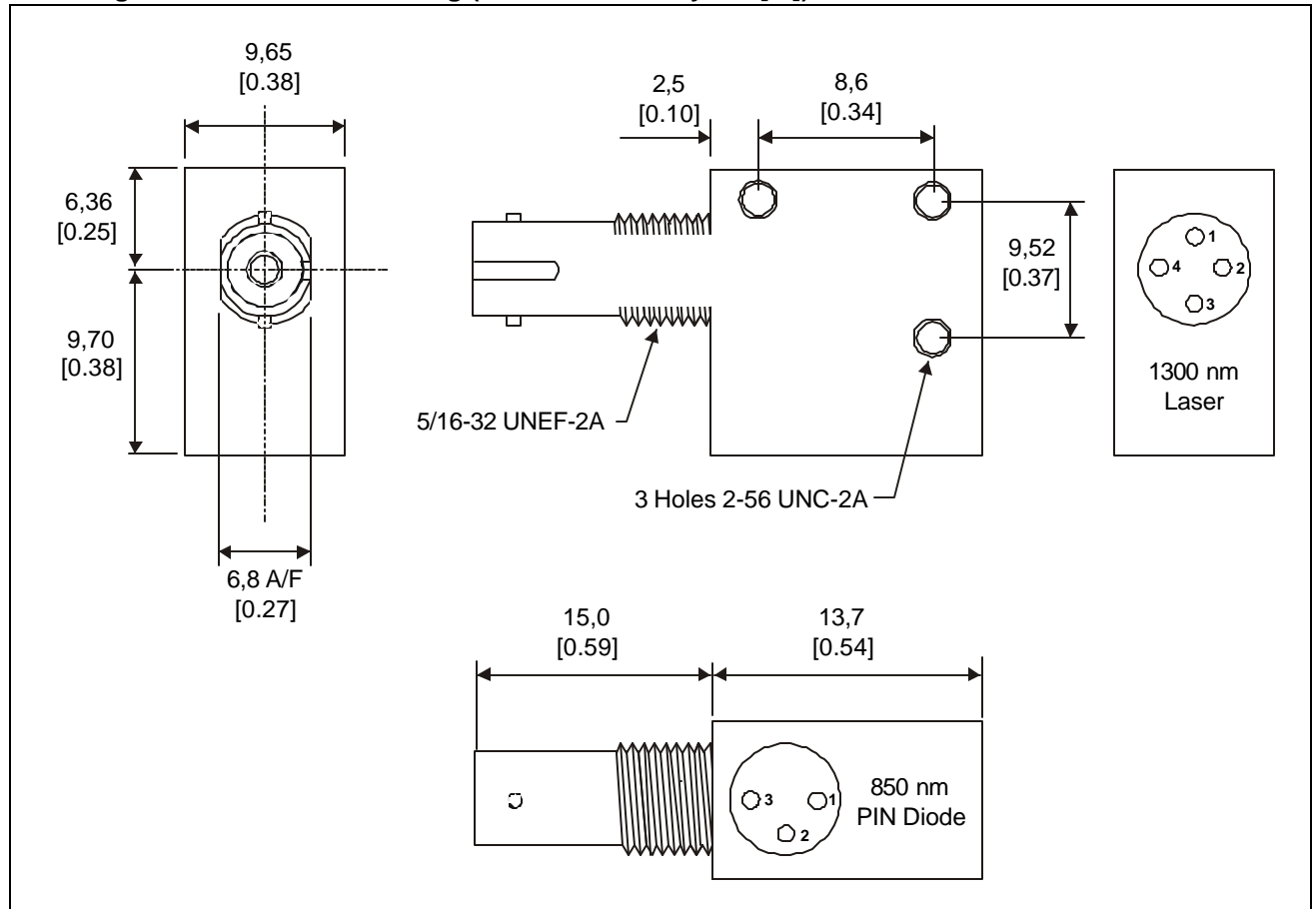

PINOUTS

850 nm PIN Diode		1300 nm Laser	
1	Anode	1	LD Anode
2	Cathode	2	PD Anode
3	Case (Ground)	3	PD Cathode
		4	LD Cathode

Infrared Products

Single Fiber Duplex Modules

HOD2236-111/BBA

HOD4090-111/BBA

ELECTRO-OPTICAL CHARACTERISTICS FOR THE HOD4090-111/BBA

Absolute Maximum Ratings (25 °C unless otherwise noted)

Continuous Forward Current	100 mA
Lead Solder Temperature	260 °C [500 °F], 10 sec
Operating Temperature	-0 °C to 70 °C (32 °F to 158 °F)
Storage Temperature	-45 °C to 85 °C (-49 °F to 185 °F)

CAUTION

STRESS DAMAGE

Functional operation of the device at or above "Absolute Maximum Ratings" for extended periods of time may affect reliability.

Failure to comply with these instructions may result in product damage.

Transmit: 850 nm VCSEL (All tests made at 25 °C unless otherwise specified.)

Parameter	Symbol	Min.	Typ.	Max.	Units	Test Conditions
Fiber Coupled Power	P_{OC}	200 -7	300 -5.2	400 -4	μ W	$I_F=12$ mA 50/125 μ m fiber
Laser Classification				Class 1		$I_F < 15$ mA dc
Threshold Current	I_{TH}		3.6	6	mA	
I_{TH} Temperature Variation	ΔI_{TH}	-1		1	mA	$T_A=0$ °C to 70 °C
Slope Efficiency	η	0.1	0.2	0.4	mW/mA	$P_O=1.3$ mW
η Temperature Variation	$\Delta \eta$		-0.4		%/°C	$T_A=0$ °C to 70 °C
Peak Wavelength	λ_p	820	850	860	nm	$I_F=12$ mA dc
λ_p Temperature Coefficient	$\Delta \lambda_p / \Delta T$		0.06		nm/°C	$I_F=12$ mA
Spectral Bandwidth	$\Delta \lambda$			0.85	nm	$I_F=12$ mA
Laser Forward Voltage	V_F	1.6	1.8	2.2	V	$I_F=12$ mA
Laser Reverse Voltage	BVR_{LD}	5	10		V	$I_R=10$ μ A
Response Time						
-40 °C < T < 100 °C, 10%-90%	t_r		100	300	ps	Bias above threshold
-40 °C < T < 100 °C, 90%-10%	t_f		100	300		
Relative Intensity Noise	RIN		-128	-122	dB/Hz	1 GHz BW
Series Resistance	R_S	15	25	50	Ohms	$I_F=12$ mA
Monitor Current	I_{PD}	0.020		0.044	mA	$P_O=1.3$ mW
I_{PD} Temperature Variation	$\Delta I_{PD} / \Delta T$		0.2		%/°C	$P_O=0.5$ mW
Dark Current	I_D			20	NA	$P_O=0$ mW, $V_R=3$ V
PD Reverse Voltage	BVR_{PD}	30	115		V	$P_O=0$ mW, $I_R=10$ μ A
PD Capacitance	C		100 55		pF	$V_R=0$ V, Freq=1 MHz $V_R=3$ V, Freq=1 MHz

Receive: 1300 nm PIN Diode (All tests made at 25 °C unless otherwise specified.)

Parameter	Symbol	Min.	Typ.	Max.	Units	Test Conditions
Flux Responsivity	R	0.45	0.50		A/W	$\lambda=1300$ nm
Dark Current	I_D		2.0	5.0	nA	$V_R=5$ V, $f=1$ MHz
Response Time						
10%-90%	t_r			1	ns	$\lambda=1300$ nm
90%-10%	t_f			1		
Cut Off Frequency	FC		1500		MHz	$V_R=5$ V, $R_L=50$ Ω
Capacitance	C		1.5	1.7	pF	$V_R=5$ V, $f=1$ MHz
Maximum Reverse Voltage	V_{Rmax}			20	V	
Isolation	I_{CX}		40		dB	I_F (LED)=100 mA dc

Infrared Products

Single Fiber Duplex Modules

HOD2236-111/BBA
HOD4090-111/BBA

CAUTION

PRODUCT DAMAGE DUE TO ESD

Ensure normal ESD (Electrostatic Discharge) precautions are followed when handling this product.
Failure to comply with these instructions may result in product damage.

HOD4090-111/BBA Duplex Module

Mounting and Dimensional Drawing (for reference only mm[in])

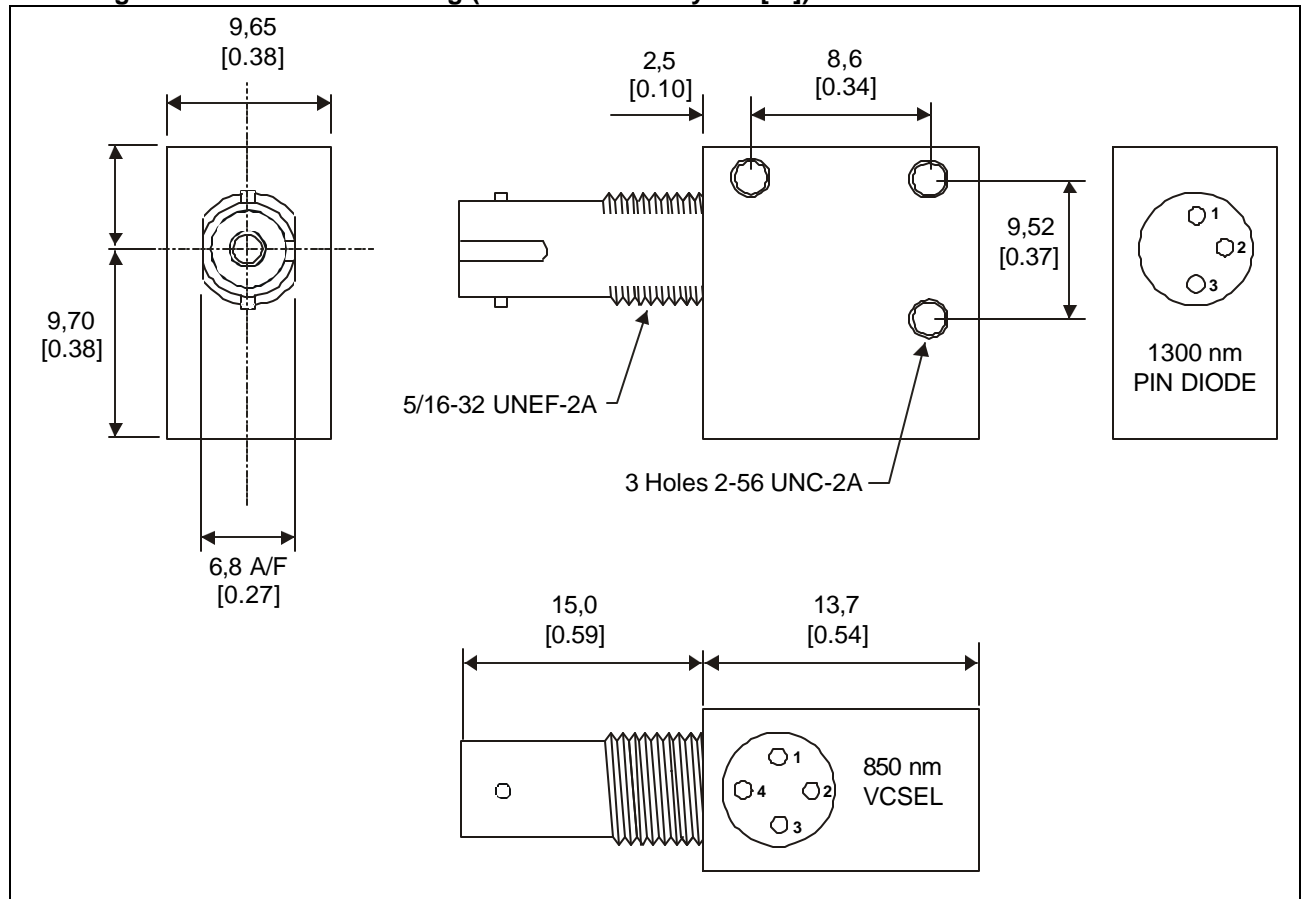

PINOUTS

850 nm VCSEL		1300 nm PIN Diode	
1	Case (Ground)	1	Anode
2	Cathode	2	Cathode
3	Anode	3	Case (Ground)
4	Cathode		

Infrared Products

Single Fiber Duplex Modules

HOD2236-111/BBA
HOD4090-111/BBA

Duplex Module Catalog Listing Numbering Scheme

HOD	XX*	XX*	-	X	X	X	/	X	X	X
	Port 1 Device	Port 2 Device		Port 1 Speed (Rise/Fall Time)	Port 2 Speed (Rise/Fall Time)	Optical Budget		Connector	Mounting	Leads
	1x 850 nm LED	1x 850 nm LED		1 <3 ns	1 <3 ns	1 <10 dB		A SMA	B PCB	A Normal
	2x 1300 nm LED/Laser	2x 1300 nm LED/Laser		2 <6 ns	2 <6 ns	2 <20 dB		B ST Low Profile	X Special	B Formed
	3x 850 nm PIN	3x 850 nm PIN		3 <10 ns	3 <10 ns	3 <30 dB		C FC		C Special
	4x 1300 nm PIN	4x 1300 nm PIN		4 <20 ns	4 <20 ns	4 <40 dB		D ST Close Mount		
	5x 850 nm P+P	5x 850 nm P+P						E SC		
	6x 1300 nm P+P	6x 1300 nm P+P						F LC		
	7x Future	7x Future						G E2000		
	8x Future	8x Future						X Special		
	9x Honeywell VCSEL	9x Honeywell VCSEL								

*The second digit of each pair of port device numbers corresponds to the specific device used.

Example: HOD4013-132/BBA defines:

40	1300 nm PIN in Port 1 (on axis)
13	850 nm LED in Port 2 (perpendicular axis)
-	
1	<3 ns Rise/Fall Time (1300 nm PIN)
3	<10 ns Rise/Fall Time (850 nm LED)
2	20 dB link budget when used with corresponding duplexer
/	
B	ST Low profile connector
B	PCB mounting
A	Normal leads

WARRANTY/REMEDY

Honeywell warrants goods of its manufacture as being free of defective materials and faulty workmanship. Contact your local sales office for warranty information. If warranted goods are returned to Honeywell during the period of coverage, Honeywell will repair or replace without charge those items it finds defective. The foregoing is Buyer's sole remedy and is **in lieu of all other warranties, expressed or implied, including those of merchantability and fitness for a particular purpose.**

Specifications may change without notice. The information we supply is believed to be accurate and reliable as of this printing. However, we assume no responsibility for its use.

While we provide application assistance personally, through our literature and the Honeywell web site, it is up to the customer to determine the suitability of the product in the application.

For application assistance, current specifications, or name of the nearest Authorized Distributor, check the Honeywell web site or call:

1-800-537-6945 USA
1-800-737-3360 Canada
44 1698 481481 Europe
1-815-235-6847 International

FAX

1-815-235-6545 USA

INTERNET

www.honeywell.com/sensing
info.sc@honeywell.com

Honeywell

Control Products

Honeywell
11 West Spring Street
Freeport, Illinois 61032



Printed with Soy Ink
on 50% Recycled Paper

www.honeywell.com/sensing

006469-1-EN IL50 GLO 702 Printed in USA

Infrared Products

Single Fiber Duplex Modules

HOD2294-111/EBA
HOD1121-411/EBA

FEATURES

- Full multiplex over single fiber
- DC to 160 MHz link bandwidth
- Link budgets of 2 km [1.24 miles] or greater
- 40 dB isolation
- SC connector
- Other options available
- VCSEL is Class 1 eye safe

APPLICATIONS

- Full duplex data transmission
- Multiplexing two signals to a single fiber
- LED and laser coupled power measurements and reflected power measurements (depending upon the configuration of the duplex module)

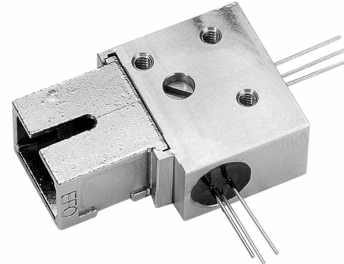

A pair of Honeywell HODXXXX-XXX/EBA series dual wavelength fiber duplex modules allows full duplex communications over a single fiber link. They may also be used where a dual fiber solution is neither possible nor economical.

Each duplex module consists of one on-axis port and one off-axis port, each configured with the appropriate devices. These devices are coupled to the single fiber via integral lenses and a 3 dB wavelength differentiating mirror within the duplex module body. In this configuration, two duplex modules can communicate in the same direction simultaneously and independently of each other. Depending upon the receiver circuitry used, links of 2 km [1.24 miles] or greater are possible.

The following catalog listings indicate the two devices used in each duplex module.

- HOD2294-111/EBA:
 - 850 nm VCSEL (Vertical Cavity Surface Emitting Laser)
 - 1300 nm laser
- HOD1121-411/EBA (corresponding duplex module):
 - 850 nm LED
 - 1300 nm LED

Other standard options are available on request. These include two LEDs in one duplex module for single fiber multiplexing, PIN diodes, VCSEL emitters or any other preferred devices. Housing options include SC and ST optical ports or a high profile housing for mounting duplex modules side by side. Future connectors will likely include SMA, FC, LC and E2000 options. See the catalog listing numbering scheme on the back page for a complete list of available configurations.

⚠ WARNING

MISUSE OF DOCUMENTATION

- The information presented in this product sheet (or catalog) is for reference only. DO NOT USE this document as product installation information.
- Complete installation, operation and maintenance information is provided in the instructions supplied with each product.

Failure to comply with these instructions could result in death or serious injury.

⚠ WARNING

PERSONAL INJURY

- DO NOT USE these products as safety or emergency stop devices or in any other application where failure of the product could result in personal injury.

Failure to comply with these instructions could result in death or serious injury.

Infrared Products

Single Fiber Duplex Modules

HOD2294-111/EBA

HOD1121-411/EBA

ELECTRO-OPTICAL CHARACTERISTICS FOR THE HOD2294-111/EBA

Absolute Maximum Ratings (25 °C unless otherwise noted)

Continuous Forward Current	20 mA (VCSEL), 100 mA (850 nm LED)
Reverse Voltage	5 V (VCSEL), 1 V at 10 μ A (850 nm LED)
Lead Solder Temperature	260 °C [500 °F], 10 sec
Operating Temperature	0 °C to 70 °C (32 °F to 158 °F)
Storage Temperature	-40 °C to 100 °C (-40 °F to 212 °F)

CAUTION

STRESS DAMAGE

Functional operation of the device at or above "Absolute Maximum Ratings" for extended periods of time may affect reliability.

Failure to comply with these instructions may result in product damage.

Transmit: 1300 nm Laser (All tests made at 25 °C unless otherwise specified.)

Parameter	Symbol	Min.	Typ.	Max.	Units	Test Conditions
Fiber Coupled Power	P_{OC}	200 -7.0	280 -5.5		μ W dBm	$I_F=20$ mA 50/125 μ m fiber
Laser Diode Reverse Voltage	V_{RLD}			2.0	V	
Photo Diode Reverse Voltage	V_{RPD}			10	V	
Photo Diode Forward Current	V_{FPD}			1	mA	
Slope Efficiency	SE	0.3	0.35		mW/mA	CW, $P_o=5$ mW
Threshold Current	I_{TH}		12	20	mA	CW, $P_o=5$ mW
Peak Wavelength	λ_p	1290	1310	1330	nm	CW, $P_o=5$ mW
Spectral Bandwidth	$\Delta\lambda$		2	5	nm	CW, $P_o=5$ mW
Forward Voltage	V_F		1.2	1.5	V	CW, $P_o=5$ mW
Response Time	t_r/t_f			0.5	ns	$I_{BIAS}=I_{TH}$ 10%-90%
Photo Diode Monitor Current	I_m	100			μ A	CW, $P_o=5$ mW, $V_{RPD}=2$ V
Photo Diode Dark Current	I_{DARK}			0.1	μ A	$V_{RLD}=5$ V
Photo Diode Capacitance	C		6	15	pF	$V_{RLD}=5$ V, $f=1$ MHz

Transmit: 850 nm VCSEL (All tests made at 25 °C unless otherwise specified.)

Parameter	Symbol	Min.	Typ.	Max.	Units	Test Conditions
Fiber Coupled Power	P_{OC}	200	280		μ W	$I_F=12$ mA 50/125 μ m fiber
Threshold Current	I_{TH}		3.6	6	mA	
I_{TH} Temperature Variation	ΔI_{TH}	-1		1	mA	$T_A=0$ °C to 70 °C
Slope Efficiency	η	0.1	0.2	0.4	mW/mA	$P_o=1.3$ mW
η Temperature Variation	$\Delta\eta$		-0.4		%/°C	$T_A=0$ °C to 70 °C
Peak Wavelength	λ_p	820	850	860	nm	$I_F=12$ mA dc
λ_p Temperature Coefficient	$\Delta\lambda_p/\Delta T$		0.06		nm/°C	$I_F=12$ mA
Spectral Bandwidth	$\Delta\lambda$			0.85	nm	$I_F=12$ mA
Laser Forward Voltage	V_F	1.6	1.8	2.2	V	$I_F=12$ mA
Laser Reverse Voltage	BV_{RLD}	5	10		V	$I_R=10$ μ A
Response Time	t_r t_f		100 100	300 300	Ps	bias above threshold
Relative Intensity Noise	RIN		-128	-122	dB/Hz	1 GHz BW
Series Resistance	R_S	15	25	50	Ohms	$I_F=12$ mA
Monitor Current	I_{PD}	0.020		0.044	mA	$P_o=1.3$ mW
I_{PD} Temperature Variation	$\Delta I_{PD}/\Delta T$		0.2		%/°C	$P_o=0.5$ mW
Dark Current	I_D			20	nA	$P_o=0$ mW, $V_R=3$ V
PD Reverse Voltage	BV_{RPD}	30	115		V	$P_o=0$ mW, $I_R=10$ μ A
PD Capacitance	C		100 55		p	$V_R=0$ V, Freq=1 MHz $V_R=3$ V, Freq=1 MHz

Infrared Products

Single Fiber Duplex Modules

HOD2294-111/EBA
HOD1121-411/EBA

CAUTION

PRODUCT DAMAGE DUE TO ESD

Ensure normal ESD (Electrostatic Discharge) precautions are followed when handling this product.
Failure to comply with these instructions may result in product damage.

HOD2294-111/EBA Duplex Module

Mounting and Dimensional Drawing (for reference only mm[in])

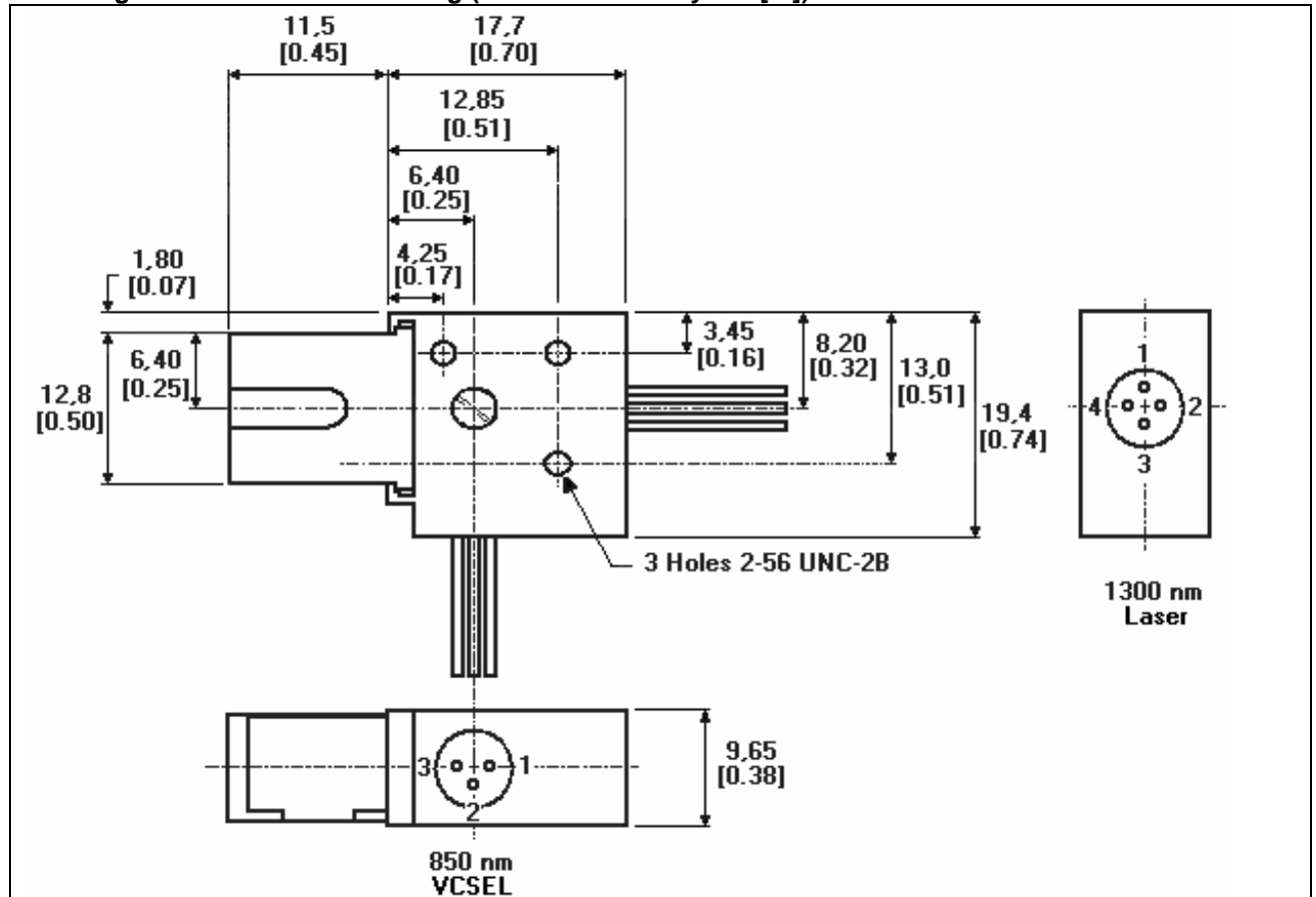

PINOOTS			
850 nm VCSEL		1300 nm Laser	
1	LD Anode	1	LD Anode
2	LD Cathode/PD Cathode	2	PD Anode
3	PD Cathode	3	PD Cathode
		4	LD Cathode

Infrared Products

Single Fiber Duplex Modules

HOD2294-111/EBA

HOD1121-411/EBA

ELECTRO-OPTICAL CHARACTERISTICS FOR THE HOD1121-411EBA

Absolute Maximum Ratings (25 °C unless otherwise noted)

Continuous Forward Current	20 mA (VCSEL), 100 mA (850 nm LED)
Reverse Voltage	5 V (VCSEL), 1 V at 10 μ A (850 nm LED)
Lead Solder Temperature	260 °C [500 °F], 10 sec
Operating Temperature	0 °C to 70 °C (32 °F to 158 °F)
Storage Temperature	-40 °C to 100 °C (-40 °F to 212 °F)

CAUTION

STRESS DAMAGE

Functional operation of the device at or above "Absolute Maximum Ratings" for extended periods of time may affect reliability.

Failure to comply with these instructions may result in product damage.

Transmit: 850 nm LED (all tests made at 25 °C unless otherwise specified)

Parameter	Symbol	Min.	Typ.	Max.	Units	Test Conditions
Fiber Coupled Power	P_{OC}		16 -18.0		μ W dBm	$I_F=20$ mA 62.5/125 μ m fiber
Forward Voltage	V_F		1.5		V	$I_F=10$ mA
Reverse voltage	BVR	1.0	5.0		V	$I_F=10$ μ A
Peak Wavelength	λ_p		850		nm	$I_F=25$ mA dc
Spectral Bandwidth	$\Delta\lambda$		60		nm	$I_F=25$ mA dc
Response Time						
10%-90%	t_r		12	20	ns	1 V prebias, 50 mA peak
90%-10%	t_f		12	20		
Analog Bandwidth	BWE		70		MHz	$I_F=50$ mA dc
Po Temperature Coefficient	$\Delta P_O/\Delta T$		-0.007		dB/°C	$I_F=50$ mA
Capacitance	C		70		pF	$V_R=0$ V, $f=1$ MHz
Thermal Resistance			250		°C/W	heatsinked

Transmit: 1300 nm LED (All tests made at 25 °C unless otherwise specified)

Parameter	Symbol	Min.	Typ.	Max.	Units	Test Conditions
Fiber Coupled Power	P_{OC}		16 -18.0		μ W dBm	$I_F=40$ mA 62.5/125 μ m fiber
Forward Voltage	V_F		1.4	1.7	V	$I_F=100$ mA
Reverse voltage	V_R			2.0		$I_F=2$ μ A
Peak Wavelength	λ_p	1290		1350	nm	$I_F=100$ mA dc
Spectral Bandwidth	$\Delta\lambda$			170	nm	$I_F=100$ mA dc
Response Time						
10%-90%	t_r		2.5	4	ns	$I_F=100$ mA, 50% duty cycle, $f=12.5$ MHz
90%-10%	t_f		2.5	4		
Analog Bandwidth	BWE		115		MHz	$I_F=100$ mA
Po Temperature Coefficient	$\Delta P_O/\Delta T$		-0.03		dB/°C	$I_F=100$ mA
Capacitance	C		15	50	pF	$V_R=3$ V, $f=1$ MHz

Infrared Products

Single Fiber Duplex Modules

HOD2294-111/EBA
HOD1121-411/EBA

CAUTION

PRODUCT DAMAGE DUE TO ESD

Ensure normal ESD (Electrostatic Discharge) precautions are followed when handling this product.

Failure to comply with these instructions may result in product damage.

HOD1121-411/EBA Duplex Module

Mounting and Dimensional Drawing (for reference only mm[in])

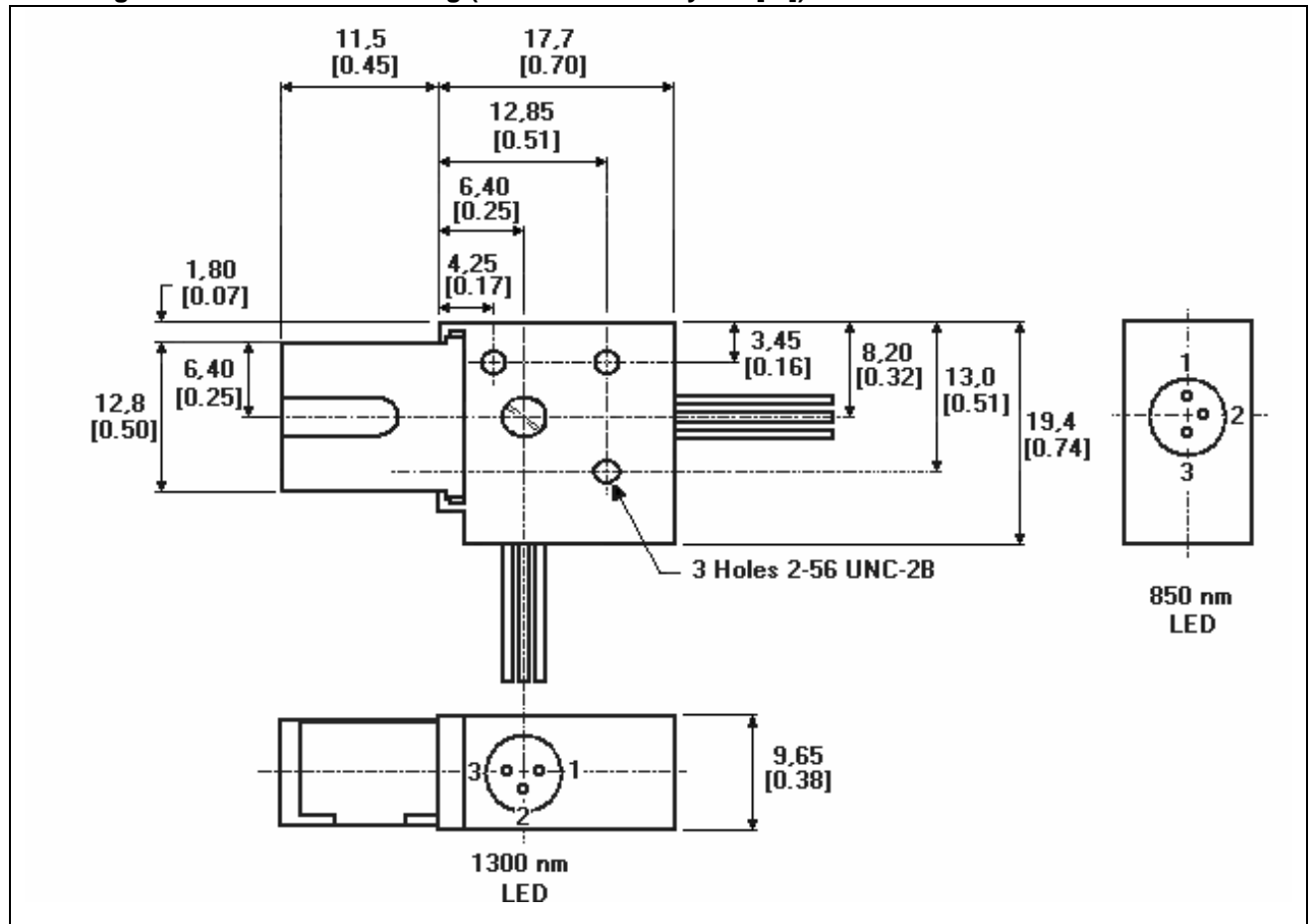

PINOUTS

1300 nm LED		850 nm LED	
1	Anode	1	Anode (Case)
2	Cathode	2	Cathode
3	Case	3	Not Connected

Infrared Products

Single Fiber Duplex Modules

HOD2294-111/EBA
HOD1121-411/EBA

Duplex Module Catalog Listing Numbering Scheme

HOD	XX*	XX*	-	X	X	X	/	X	X	X
	Port 1 Device	Port 2 Device		Port 1 Speed (Rise/Fall Time)	Port 2 Speed (Rise/Fall Time)	Optical Budget		Connector	Mounting	Leads
1x	850 nm LED	1x 850 nm LED		1 <3 ns	1 <3 ns	1 <10 dB		A SMA	B PCB	A Normal
2x	1300 nm LED/Laser	2x 1300 nm LED/Laser		2 <6 ns	2 <6 ns	2 <20 dB		B ST Low Profile	X Special	B Formed
3x	850 nm PIN	3x 850 nm PIN		3 <10 ns	3 <10 ns	3 <30 dB		C FC		C Special
4x	1300 nm PIN	4x 1300 nm PIN		4 <20 ns	4 <20 ns	4 <40 dB		D ST Close Mount		
5x	850 nm P+P	5x 850 nm P+P						E SC		
6x	1300 nm P+P	6x 1300 nm P+P						F LC		
7x	Future	7x Future						G E2000		
8x	Future	8x Future						X Special		
9x	Honeywell VCSEL	9x Honeywell VCSEL								

*The second digit of each pair of port device numbers corresponds to the specific device used.

Example: HOD5721-412/EBA defines:

57	850 nm P+P in Port 1 (on axis)
21	1300 nm LED in Port 2 (perpendicular axis)
-	
4	<20 ns Rise/Fall Time (850 nm P+P)
1	<3 ns Rise/Fall Time (1300 nm LED)
2	20 dB link budget when used with corresponding duplex module
/	
E	SC connector
B	PCB mounting
A	Normal leads

WARRANTY/REMEDY

Honeywell warrants goods of its manufacture as being free of defective materials and faulty workmanship. Contact your local sales office for warranty information. If warranted goods are returned to Honeywell during the period of coverage, Honeywell will repair or replace without charge those items it finds defective. The foregoing is Buyer's sole remedy and is **in lieu of all other warranties, expressed or implied, including those of merchantability and fitness for a particular purpose.**

Specifications may change without notice. The information we supply is believed to be accurate and reliable as of this printing. However, we assume no responsibility for its use.

While we provide application assistance personally, through our literature and the Honeywell web site, it is up to the customer to determine the suitability of the product in the application.

For application assistance, current specifications, or name of the nearest Authorized Distributor, check the Honeywell web site or call:

1-800-537-6945 USA
1-800-737-3360 Canada
44 1698 481481 Europe
1-815-235-6847 International

FAX
1-815-235-6545 USA

INTERNET
www.honeywell.com/sensing
info.sc@honeywell.com

Honeywell

Control Products

Honeywell
11 West Spring Street
Freeport, Illinois 61032



Printed with Soy Ink
on 50% Recycled Paper

www.honeywell.com/sensing

006470-1-EN IL50 GLO 702 Printed in USA