

140 SERIES

STANDARD FEATURES

- Double pole, single throw
- Ratings:
10A 125VAC
8(8) 250VAC
- UL/CSA approved
- Most European approvals

OPTIONS

- Lock on
- Lock off
- Plug-in and/or screw terminals
- Various trigger styles and colors
- Various lock button styles and colors

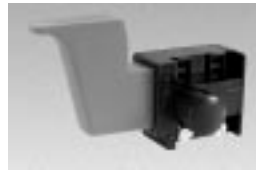

WIRING DIAGRAM

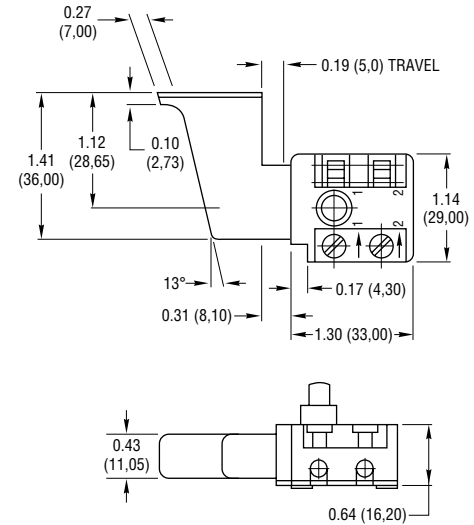
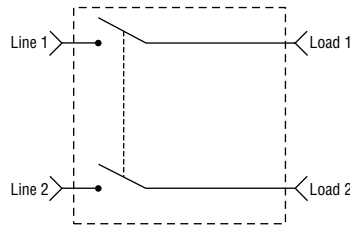

8649 SERIES VARIABLE SPEED

STANDARD FEATURES

- Single pole
- Rating:
10A 12VDC
- UL approved
- Plug-in termination

OPTIONS

- Three position reversing switch with center off
- Various trigger styles and colors
- Dynamic brake circuit
- Battery terminals
- Special speed control circuits for: 7.2, 9.6, 12, 24 and 36VDC
- Wide range of power FETS
- Various reversing lever styles and colors
- Higher ratings



WIRING DIAGRAM

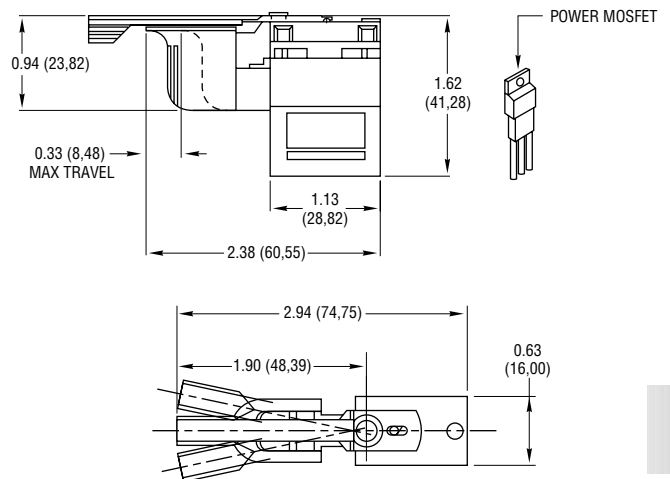
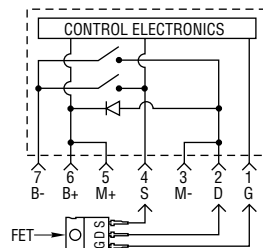

PT SERIES

STANDARD FEATURES

- Double pole, single throw
- UL/CSA approved:
22A 125VAC/DC
10A 250VAC/DC
- VDE 10 (10) 250V
- Screw termination

OPTIONS

- Alternate circuits i.e.: SPDT and alternate action
- Lock on
- Padlock hole
- Various trigger styles and colors



WIRING DIAGRAM

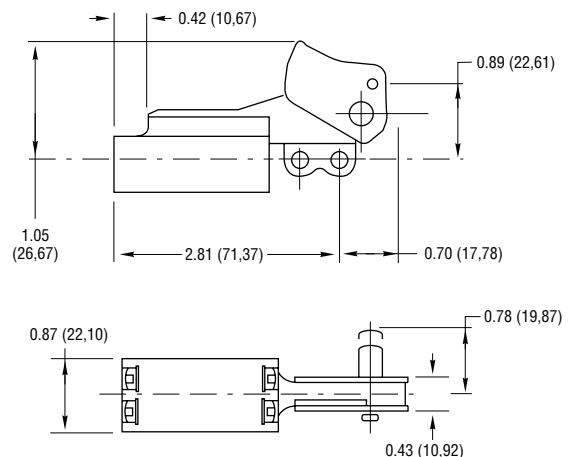
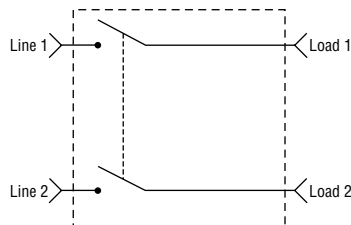

For complete product information, order Catalog 1308650

CUSTOM POWER TOOL SWITCHES

Power Tool Switches include a wide assortment of on/off utility trigger switches, dust resistant AC variable speed switches, in-line and "L" style cordless tool switches, custom battery tool switches, standard and custom industrial dynamic brake switches. These power tool switches are currently used in consumer electric hand power tools and industrial tools. Manufacturing capabilities include thick film on ceramic substrates; automated surface mount placement systems; resistive, reflow, belt reflow and infrared soldering; laser trim/test (active and passive); chip mounting, wire bonding and full encapsulation capability. In addition to our standard product offering, Tyco Electronics can adapt products and develop products which accommodate your specific needs. Working with your engineering staff at the concept stage, we can design solutions for specific customer needs.

Tyco Electronics can manufacture Power Tool Switches to your specific requirements. Contact us for more information at 800-522-6752.

CUSTOM VARIABLE SPEED AND ON/OFF TRIGGER SWITCHES



CUSTOM BATTERY TOOL SWITCHES



CUSTOM INDUSTRIAL TOOL SWITCHES



For complete product information, order Catalog 1308390