



Logic relays and Display system

CL range

Contents

System overview	354
Approvals and marks	356
Ordering details	
Logic relays	
Logic relays	357
Expansions	358
Display modules	358
Remote display connection modules	358
Power supply units	359
Accessories for logic relays	359
Display system	
Display modules	360
Display base modules	360
Display I/O-modules	360
Accessories for display system	361
Technical data	
Logic relays and expansions	362
Display modules	369
Remote display connection modules	370
Display base modules	371
Display I/O-modules	372
Dimensional drawings	376

Logic relays, display system CL range System overview



2 CDC 315 039 F0006

Concept

CL range logic relays are suitable for small and medium-sized control tasks and are able to substitute logic wiring in a quick and simple manner.

They can be used for applications in control as well as for timing functions, e. g.

- in buildings, lighting systems, air-conditioning systems, general control functions,
- in small machines and systems or
- as stand-alone control module for small applications.

Steps to the application of CL range

- CL range can be used easily, rapidly and comfortably without any time-consuming planning and programming.
- The user can discover the advantages and the benefit of these logic relays in no time at all.
- CL range provides for the control statements according to a simple circuit diagram.
- Setup, storage, simulation and documentation are performed using the compact and user-friendly CL-SOFT software (CL-LAS.PS002).

Software characteristics (CL-SOFT)

- display on a PC monitor according to IEC, ANSI
- different languages to choose from
- easy installation on all Microsoft Windows™ operating systems

Logic links instead of wiring

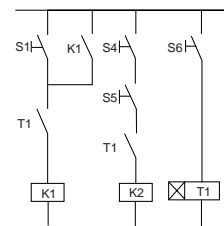

1SVC 110 000 F 0554

Documentation (download from the internet)

Logic relay manual	1SVC 440 795 M0100
Remote display manual	1SVC 440 795 M2100
Display system manual	1SVC 440 795 M1100

Logic relays, display system CL range System overview

System overview

Logic relays

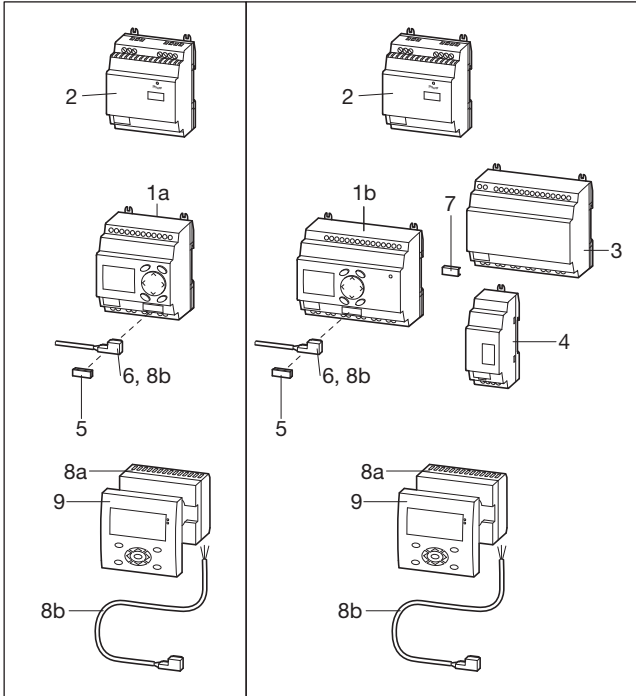

2CDC 312 001 F0b08

- 1a Logic relay CL-LS..
- 1b Expandable logic relay CL-LM..
- 2 Power supply CP-D...
- 3 I/O expansion CL-LER.., CL-LET.. for logic relays CL-LM..
- 4 Coupler unit CL-LEC.. for remote expansion of logic relays CL-LM..
- 5 Memory module CL-LAS.MD003 for logic relays CL-LS.., CL-LM..
- 6 Connecting cable CL-LAS.TK001, CL-LAS.TK002 to connect PC
- 7 CL-LINK plug CL-LAS.TK011 to connect expansion to logic relays CL-LM..
- 8a Remote display connection module CL-LDC.S..
- 8b Connecting cable CL-LAD.TK007 to connect a remote displays to a logic relay
- 9 Display module CL-LDD..

Expansion of logic relays

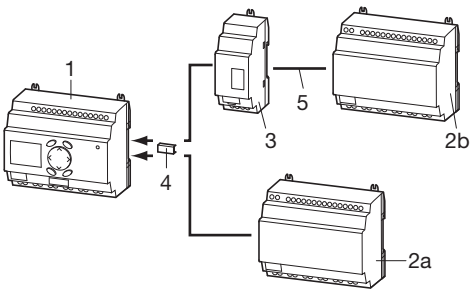

2CDC 312 037 F0b07

- 1 Logic relay CL-LM..
- 2 I/O expansion CL-LER.., CL-LET..
 - 2a local expansion
 - 2b remote expansion
- 3 Coupler unit CL-LEC.. for remote expansion of logic relays CL-LM..
- 4 CL-LINK plug CL-LAS.TK011 for expansion of logic relays CL-LM..
- 5 up to 30 m

Display system → Compact HMI logic relay

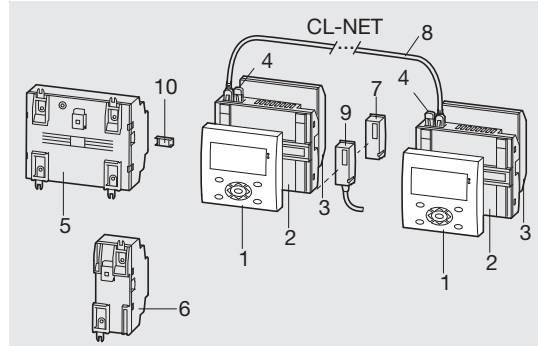

2CDC 312 025 F0b06

- 1 Display module CL-LDD..
 - 2 Display base module CL-LDC.LN..
 - 3 Display I/O module CL-LDR.., CL-LDT..
 - 4 Termination resistor CL-LAD.TK009
 - 5 I/O expansion CL-LER.., CL-LET..
 - 6 Coupler unit CL-LEC.. for remote expansion
 - 7 Memory module CL-LAD.MD004 for display base module
 - 8 Connecting cable CL-LAD.TK002, CL-LAD.TK003, CL-LAD.TK004
 - 9 Connecting cable CL-LAD.TK001, CL-LAD.TK011 to connect PC
 - 10 CL-LINK plug CL-LAS.TK011 for expansion of logic relays CL-LM..
- e.g. door of switchgear cabinet

Stand alone with I/O module

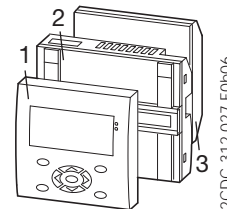

2CDC 312 027 F0b06

- 1 Display CL-LDD..
- 2 Remote display connection module CL-LDC.S.. incl. connecting cable
- 3 Display base module CL-LDC.L..

Communication via CL-NET

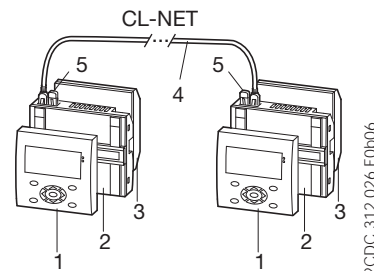

2CDC 312 026 F0b06

- 1 Display CL-LDD..
- 2 Display base module CL-LDC.LN.. for CL-NET
- 3 Display I/O module CL-LDR.., CL-LDT..
- 4 Connecting cable CL-LAD.TK002, CL-LAD.TK003, CL-LAD.TK004
- 5 Termination resistor CL-LAD.TK009

Logic relays, display system

CL range

System overview, Approvals and marks

Technical Data overview

Logic relays

- 8 or 12 digital inputs
- 4 or 6 digital relay outputs
- optionally with 4 or 8 transistor outputs
- 128 rungs
- 3 contacts as n/o or n/c contacts in series plus 1 coil per rung
- optionally with 2 or 4 analog inputs (not 100-240 V AC version)
- power flow display for checking the circuit diagram (devices with display)
- expansions for local or remote level
- enclosure color RAL 7035
- DIN rail mounting

Remote display

- Remote display up to a distance of 5 m
- Illustration of text and status displays
- Remote adjustment via keypad
- Front panel mounting

Display system

- useable as compact HMI logic relay
- fully graphic, backlit display module
- 12 digital inputs
- 4 digital relay outputs
- optionally with 4 transistor outputs
- 256 rungs
- 4 contacts as n/o or n/c contacts in series plus 1 coil per rung
- optionally with 4 analog inputs (not 100-240 V AC version)
- networking-compatible via CL-NET
- front panel mounting
- expansion for local

Software

- 16 timing relays 0.01-99:59 h
- 16 counting relays for up-, down counting
- 8 weekly timer, 8 annual timers
- 16 analog value comparators
- 16 freely editable display texts
- 32 markers or auxiliary relays

		Logic relays				Expansions			Display system				Accessories	
		CL-LSR	CL-LST	CL-LMR	CL-LMT	CL-LER	CL-LET	CL-LEC	CL-LDD	CL-LDC	CL-LDR	CL-LDT	CL-LAS	CL-LAD
Approvals														
B	UL	■	■	■	■	■	■	■	■	■	■	■	■ ¹⁾	■ ²⁾
F	CAN/CSA C22.2 No.14	■	■	■	■	■	■	■	■	■	■	■	■ ¹⁾	■ ²⁾
F	CAN/CSA C22.2 No.213 (hazardous locations)	■	■	■	■	■	■	■	■	■	■	■	■ ¹⁾	■ ²⁾
C	GL	■	■	■	■				■	■ ³⁾	■ ⁴⁾	■		
D	GOST	■	■	■	■	■	■	■	■	■	■	■	■	■
P	Lloyds Register	■	■	■	■				■	■ ³⁾	■ ⁴⁾	■		
Marks														
a	CE	■	■	■	■	■	■	■	■	■	■	■	■	■
b	C-Tick	□	□	□	□	□	□	□	□	□	□	□	□	□

¹⁾ not for: CL-LAS-PS002, CL-LAS.TD001, CL-LAS.FD001, CL-LAS.TK002, CL-LAS.TK011

²⁾ not for: CL-LAD.TK006, CL-LAD.TK011, CL-LAD.FD002

³⁾ not for: CL-LDC.SDC2, CL-LDC.SAC2, CL-LDC.LAC2, CL-LDC.LNAC2

⁴⁾ not for: CL-LDR.16AC2

Logic relays

CL-LSR., CL-LST., CL-LMR., CL-LMT..

Ordering details

2CDC 311 034 F0606



CL-LSR

2CDC 311 033 F0606



CL-LST

2CDC 311 036 F0606



CL-LMR

2CDC 311 035 F0606



CL-LMT

Type	Rated operational voltage	Display + Keypad	Timer	expandable	Order code	Pack. unit pieces	Price 1 piece	Weight 1 piece kg/lb
------	---------------------------	------------------	-------	------------	------------	-------------------	---------------	----------------------

Logic relays

CL-LSR: 8 inputs, 4 relay outputs

CL-LSR.C12AC1	24 V AC	■	■		1SVR 440 712 R0300	1		0.20/0.44
CL-LSR.CX12AC1	24 V AC		■		1SVR 440 712 R0200	1		0.20/0.44
CL-LSR.12AC2	100-240 V AC	■			1SVR 440 713 R0100	1		0.20/0.44
CL-LSR.C12AC2	100-240 V AC	■	■		1SVR 440 713 R0300	1		0.20/0.44
CL-LSR.CX12AC2	100-240 V AC		■		1SVR 440 713 R0200	1		0.20/0.44
CL-LSR.C12DC1	12 V DC	■	■		1SVR 440 710 R0300	1		0.20/0.44
CL-LSR.CX12DC1	12 V DC		■		1SVR 440 710 R0200	1		0.20/0.44
CL-LSR.12DC2	24 V DC	■			1SVR 440 711 R0100	1		0.20/0.44
CL-LSR.C12DC2	24 V DC	■	■		1SVR 440 711 R0300	1		0.20/0.44
CL-LSR.CX12DC2	24 V DC		■		1SVR 440 711 R0200	1		0.20/0.44

CL-LST: 8 inputs, 4 transistor outputs

CL-LST.C12DC2	24 V DC	■	■		1SVR 440 711 R1300	1		0.20/0.44
CL-LST.CX12DC2	24 V DC		■		1SVR 440 711 R1200	1		0.20/0.44

Expandable logic relays

CL-LMR: 12 inputs, 6 relay outputs

CL-LMR.C18AC1	24 V AC	■	■	■	1SVR 440 722 R0300	1		0.36/0.79
CL-LMR.CX18AC1	24 V AC		■	■	1SVR 440 722 R0200	1		0.36/0.79
CL-LMR.C18AC2	100-240 V AC	■	■	■	1SVR 440 723 R0300	1		0.36/0.79
CL-LMR.CX18AC2	100-240 V AC		■	■	1SVR 440 723 R0200	1		0.36/0.79
CL-LMR.C18DC1	12 V DC	■	■	■	1SVR 440 720 R0300	1		0.36/0.79
CL-LMR.CX18DC1	12 V DC		■	■	1SVR 440 720 R0200	1		0.36/0.79
CL-LMR.C18DC2	24 V DC	■	■	■	1SVR 440 721 R0300	1		0.36/0.79
CL-LMR.CX18DC2	24 V DC		■	■	1SVR 440 721 R0200	1		0.36/0.79

CL-LMT: 12 inputs, 8 transistor outputs

CL-LMT.C20DC2	24 V DC	■	■	■	1SVR 440 721 R1300	1		0.36/0.79
CL-LMT.CX20DC2	24 V DC		■	■	1SVR 440 721 R1200	1		0.36/0.79

- Approvals356
- Technical data363
- Dimensional drawings376

Logic relays Accessories - CL-LE., CL-LD.. Ordering details

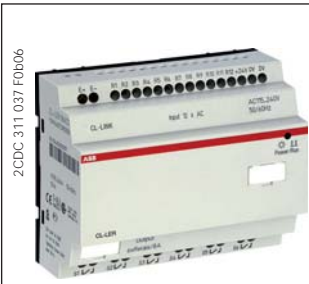

CL-LER



CL-LEC



CL-LDD.K



CL-LDC.S..

Type	Rated operational voltage	Order code	Pack. unit pieces	Price 1 piece	Weight 1 piece kg/lb
------	---------------------------	------------	-------------------	---------------	----------------------

Expansions

CL-LER: 2 relay outputs

CL-LER.20	-	1SVR 440 709 R5000	1		0.07/0.15
-----------	---	--------------------	---	--	-----------

CL-LER: 12 inputs, 6 relay outputs

CL-LER.18AC2	100-240 V AC	1SVR 440 723 R0000	1		0.26/0.57
CL-LER.18DC2	24 V DC	1SVR 440 721 R0000	1		0.22/0.49

CL-LER: 12 inputs, 8 transistor outputs

CL-LER.20DC2	24 V DC	1SVR 440 721 R1000	1		0.21/0.46
--------------	---------	--------------------	---	--	-----------

Coupler unit

CL-LEC: Coupler unit for remote expansion with a distance of up to 30 m

CL-LEC.CI000	-	1SVR 440 709 R0000	1		0.07/0.15
--------------	---	--------------------	---	--	-----------

Type	Rated operational voltage	Order code	Pack. unit pieces	Price 1 piece	Weight 1 piece kg/lb
------	---------------------------	------------	-------------------	---------------	----------------------

Display modules

CL-LDD: Graphic display 132 x 64 pixel

CL-LDD.XK	-	1SVR 440 839 R4500	1		0.14/0.30
-----------	---	--------------------	---	--	-----------

CL-LDD: Graphic display 132 x 64 pixel, with keypad

CL-LDD.K	-	1SVR 440 839 R4400	1		0.13/0.29
----------	---	--------------------	---	--	-----------

Remote display connection modules

CL-LDC: Module to displace the display from the logic relay, incl. connecting cable CL-LAD.TK007, 5 m, length adaptable

CL-LDC.SDC2	24 V DC	1SVR 440 841 R0000	1		0.16/0.36
CL-LDC.SAC2	100-240 V AC	1SVR 440 843 R0000	1		0.16/0.36

- Approvals356
- Technical data365
- Dimensional drawings376

Logic relays Accessories - CL-LA..

Ordering details

2CDC 311 012 F0607



CL-LAS.PS002

2CDC 311 013 F0607



CL-LAS.MD003

2CDC 311 014 F0607



CL-LAS.TK001

2CDC 311 031 F0607



CL-LAS.TK011

2CDC 271 027 F0607



CP-D 24/1.3

Type	Description	Order code	Pack. unit pieces	Price 1 piece	Weight 1 piece kg/lb
------	-------------	------------	-------------------	---------------	----------------------

Software for CL range (CL-SOFT)

CL-LAS: Software for programming and control of CL range devices

CL-LAS.PS002	Installation CD-ROM for Microsoft Windows™	1SVR 440 799 R8000	1		0.10/0.21
--------------	--	--------------------	---	--	-----------

Memory module

CL-LAS: Memory module for logic relays

CL-LAS.MD003	Memory size: 32 kB	1SVR 440 799 R7000	1		0.02/0.04
--------------	--------------------	--------------------	---	--	-----------

Connecting cables

CL-LAS: Cable with serial interface to connect PC and logic relay

CL-LAS.TK001	Length: 2 m	1SVR 440 799 R6000	1		0.10/0.22
--------------	-------------	--------------------	---	--	-----------

CL-LAS: Cable with USB interface to connect PC and logic relay

CL-LAS.TK002	Length:	1SVR 440 799 R6100	1		
--------------	---------	--------------------	---	--	--

CL-LAD: Cable for point-to-point connection of remote-display connection module and logic relay, length adaptable

CL-LAD.TK007	Length: 5 m	1SVR 440 899 R6600	1		0.20/0.44
--------------	-------------	--------------------	---	--	-----------

Fixing brackets

CL-LAS: Fixing brackets for screw mounting of logic relay, expansion, display base module

CL-LAS.FD001	content: 9 fixing brackets	1SVR 440 799 R5000	1		0.01/0.01
--------------	----------------------------	--------------------	---	--	-----------

Connecting plug

CL-LAS: Spare plug (CL-LINK) for connection of logic relay to expansion

CL-LAS.TK011	CL-LINK	1SVR 440 799 R5100	1		0.10/0.22
--------------	---------	--------------------	---	--	-----------

Type	Rated input voltage	Rated output voltage / current	Order code	Pack. unit pieces	Price 1 piece	Weight 1 piece kg/lb
------	---------------------	--------------------------------	------------	-------------------	---------------	----------------------

Simulator

CL-LAS: Input-/ output simulator with wall power supply, fits to CL-LSR and CL-LST

CL-LAS.TD001	100-240 V AC	24 V DC	1SVR 440 793 R0000	1		0.19/0.43
--------------	--------------	---------	--------------------	---	--	-----------

Power supplies

CP-D: Primary switch mode power supplies

CP-D 24/0.42 ¹⁾	100-240 V AC	24 V DC / 0.42 A	1SVR 427 041 R0000	1		0.06/0.13
CP-D 24/1.3 ²⁾	100-240 V AC	24 V DC / 1.3 A	1SVR 427 043 R0100	1		0.19/0.41

¹⁾ replaces CL-LAS.SD001, technical data see chapter "Primary switch mode power supplies"

²⁾ replaces CL-LAS.SD002, technical data see chapter "Primary switch mode power supplies"

- Approvals356
- Dimensional drawings376

Display system

CL-LD..

Ordering details

2CDC 311 028 F0006



CL-LDD.K

2CDC 311 031 F0006



CL-LDC.LN..

2CDC 311 032 F0006



CL-LDR

Type	Rated operational voltage	Order code	Pack. unit pieces	Price 1 piece	Weight 1 piece kg/lb
------	---------------------------	------------	-------------------	---------------	----------------------

Display modules

CL-LDD: Graphic display 132 x 64 pixel

CL-LDD.XK	-	1SVR 440 839 R4500	1		0.14/0.30
------------------	---	---------------------------	---	--	-----------

CL-LDD: Graphic display 132 x 64 pixel, with keypad

CL-LDD.K	-	1SVR 440 839 R4400	1		0.13/0.29
-----------------	---	---------------------------	---	--	-----------

Display base modules

CL-LDC: CPU / power supply

CL-LDC.LDC2	24 V DC	1SVR 440 821 R0000	1		0.16/0.36
--------------------	---------	---------------------------	---	--	-----------

CL-LDC.LAC2	100-240 V AC	1SVR 440 823 R0000	1		0.16/0.36
--------------------	--------------	---------------------------	---	--	-----------

CL-LDC: CPU / power supply, networking-compatible (CL-NET)

CL-LDC.LNDC2	24 V DC	1SVR 440 821 R1000	1		0.17/0.38
---------------------	---------	---------------------------	---	--	-----------

CL-LDC.LNAC2	100-240 V AC	1SVR 440 823 R1000	1		0.17/0.38
---------------------	--------------	---------------------------	---	--	-----------

Display I/O modules

CL-LDR: 12 inputs, 4 relay outputs

CL-LDR.16AC2	100-240 V AC	1SVR 440 853 R0000	1		0.17/0.38
---------------------	--------------	---------------------------	---	--	-----------

CL-LDR.16DC2	24 V DC	1SVR 440 851 R0000	1		0.17/0.38
---------------------	---------	---------------------------	---	--	-----------

CL-LDR: 12 inputs, 4 relay outputs, 1 analog output

CL-LDR.17DC2	24 V DC	1SVR 440 851 R2000	1		0.17/0.38
---------------------	---------	---------------------------	---	--	-----------

CL-LDT: 12 inputs, 4 transistor outputs

CL-LDT.16DC2	24 V DC	1SVR 440 851 R1000	1		0.14/0.30
---------------------	---------	---------------------------	---	--	-----------

CL-LDT: 12 inputs, 4 transistor outputs, 1 analog output

CL-LDT.17DC2	24 V DC	1SVR 440 851 R3000	1		0.14/0.30
---------------------	---------	---------------------------	---	--	-----------

• Approvals	356	• Dimensional drawings	376
• Technical data	369		

Display system Accessories - CL-LAD..

Ordering details

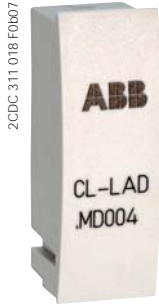

CL-LAD.MD004



CL-LAD.TK001



CL-LAD.TK002



CL-LAD.TK009

Type	Description	Order code	Pack. unit pieces	Price 1 piece	Weight 1 piece kg/lb
------	-------------	------------	-------------------	---------------	----------------------

Memory module

CL-LAD: Memory module for display base modules

CL-LAD.MD004	Memory size: 256 kB	1SVR 440 899 R7000	1		0,02/0.03
--------------	---------------------	--------------------	---	--	-----------

Connecting cables

CL-LAD: Cable with serial interface to connect PC and display base module

CL-LAD.TK001	Length: 2 m	1SVR 440 899 R6000	1		0.11/0.23
--------------	-------------	--------------------	---	--	-----------

CL-LAD: Cable with USB interface to connect PC and display base module

CL-LAD.TK011	Length:	1SVR 440 899 R6700	1		
--------------	---------	--------------------	---	--	--

CL-LAD: Network cable (CL-NET) to connect 2 display base modules

CL-LAD.TK002	Length: 0.3 m	1SVR 440 899 R6100	1		0.05/0.12
CL-LAD.TK003	Length: 0.8 m	1SVR 440 899 R6200	1		0.07/0.14
CL-LAD.TK004	Length: 1.5 m	1SVR 440 899 R6300	1		0.08/0.18

CL-LAD: Cable for point-to-point connection of remote display connection modules and display base module, length adaptable

CL-LAD.TK005	Length: 5 m	1SVR 440 899 R6400	1		0.20/0.44
--------------	-------------	--------------------	---	--	-----------

CL-LAD: Cable for point-to-point connection of 2 display base modules, length adaptable

CL-LAD.TK006	Length: 5 m	1SVR 440 899 R6500	1		0.12/0.26
--------------	-------------	--------------------	---	--	-----------

Termination resistor

CL-LAD: Termination resistor

CL-LAD.TK009	content: 2 pieces	1SVR 440 899 R6900	1		0.01/0.02
--------------	-------------------	--------------------	---	--	-----------

Protective covers

CL-LAD: Protective cover, transparent, for harsh environmental conditions and application in the food industry

CL-LAD.FD001	-	1SVR 440 899 R1000	1		0.03/0.07
--------------	---	--------------------	---	--	-----------

CL-LAD: Protective cover, transparent and sealable

CL-LAD.FD011	-	1SVR 440 899 R2000	1		0.03/0.07
--------------	---	--------------------	---	--	-----------

Assembly tool

CL-LAD: Tool for mounting of display modules

CL-LAD.FD002	-	1SVR 440 899 R3000	1		
--------------	---	--------------------	---	--	--

• Approvals356

Logic relays

CL-LS., CL-LM., CL-LER., CL-LET.

Technical data / Input circuit - supply circuit

Data at $T_a = 25\text{ °C}$ and rated values, if nothing else indicated.

Type	CL-LSR.C...12DC1	CL-LSR...12DC2 CL-LST.C...12DC2	CL-LSR.C...12AC1	CL-LSR...12AC2
Input circuit - supply circuit				
Rated operational voltage U_o	12 V DC	24 V DC	24 V AC	100-240 V AC
Rated operational voltage tolerance	-15...+30 %	-15...+20 %	-15...+10 %	
Operational voltage range	10.2-15.6 V DC	20.4-28.8 V DC	20.4-26.4 V AC	85-264 V AC
Rated frequency	0 Hz		50/60 Hz	
Rated frequency tolerance	-		±5 %	
Residual ripple	≤ 5 %			
Input current	typ. 140 mA	-	-	-
at 12 V DC				
at 24 V DC	-	typ. 80 mA	-	-
at 24 V AC	-	-	typ. 200 mA	-
at 115/120 V AC (60 Hz)	-	-	-	typ. 40 mA
at 230/240 V AC (50 Hz)	-	-	-	typ. 20 mA
Power failure buffering (IEC/EN 61131-2)	10 ms		20 ms	
Power dissipation	typ. 2 W	-	-	-
at 12 V DC				
at 24 V DC	-	typ. 2 W	-	-
at 24 V AC	-	-	typ. 5 VA	-
at 115/120 V AC	-	-	-	typ. 5 VA
at 230/240 V AC	-	-	-	typ. 5 VA

Type	CL-LMR.C...18DC1	CL-LMR.C...18DC2 CL-LMT.C...20DC2	CL-LMR.C...18AC1	CL-LMR.C...18AC2
Input circuit - supply circuit				
Rated operational voltage U_o	12 V DC	24 V DC	24 V AC	100-240 V AC
Rated operational voltage tolerance	-15...+30 %	-15...+20 %	-15...+10 %	
Operational voltage range	10.2-15.6 V DC	20.4-28.8 V DC	20.4-26.4 V AC	85-264 V AC
Rated frequency	0 Hz		50/60 Hz	
Rated frequency tolerance	-		±5 %	
Residual ripple	≤ 5 %			
Input current	typ. 200 mA	-	-	-
at 12 V DC				
at 24 V DC	-	typ. 140 mA	-	-
at 24 V AC	-	-	typ. 300 mA	-
at 115/120 V AC (60 Hz)	-	-	-	typ. 70 mA
at 230/240 V AC (50 Hz)	-	-	-	typ. 35 mA
Power failure buffering (IEC/EN 61131-2)	10 ms		20 ms	
Power dissipation	typ. 3.5 W	-	-	-
at 12 V DC				
at 24 V DC	-	typ. 3.5 W	-	-
at 24 V AC	-	-	typ. 7 VA	-
at 115/120 V AC	-	-	-	typ. 10 VA
at 230/240 V AC	-	-	-	typ. 10 VA

Type	CL-LER.18DC2 CL-LET.20DC2	CL-LER.18AC2		
Input circuit - supply circuit				
Rated operational voltage U_o	24 V DC	100-240 V AC		
Rated operational voltage tolerance	-15...+20 %	-15...+10 %		
Operational voltage range	20.4-28.8 V DC	85-264 V AC		
Rated frequency	0 Hz	50/60 Hz		
Rated frequency tolerance	-	±5 %		
Residual ripple	≤ 5 %			
Input current	typ. 140 mA	-		
at 24 V DC				
at 115/120 V AC (60 Hz)	-	typ. 70 mA		
at 230/240 V AC (50 Hz)	-	typ. 35 mA		
Power failure buffering (IEC/EN 61131-2)	10 ms	20 ms		
Power dissipation	typ. 3.4 W	-		
at 24 V DC				
at 115/120 V AC	-	typ. 10 VA		
at 230/240 V AC	-	typ. 10 VA		

Logic relays CL-LSR., CL-LST..

Technical data / Input circuit - inputs

Data at $T_a = 25\text{ °C}$ and rated values, if nothing else indicated.

Type	CL-LSR.C...12DC1	CL-LSR....12DC2 CL-LST.C...12DC2	CL-LSR.C...12AC1	CL-LSR.C...12AC2
Input circuit - Digital inputs	12 V DC	24 V DC	24 V AC	115 / 230 V AC
Number	8			
Inputs can be used as analog inputs	2 (I7, I8)			-
Indication of operational states	LCD-Display (if existing)			
Electrical isolation	from voltage supply	no		
	between digital inputs	no		
	from the outputs	yes		
Rated operational voltage U_e	12 V DC	24 V DC	24 V AC	
	U_e on „0“ signal	4 V DC (I1-I8)	< 5 V DC (I1-I8)	0-6 V AC (sinusoidal)
	U_e on „1“ signal	8 V DC (I1-I8)	> 15 V DC (I1-I6), > 8 V DC (I7, I8)	> 9,5 V DC, 14-26,4 V AC (sinusoidal) (I1-I6), > 7 V AC (sinusoidal) (I7,I8)
Rated frequency	-		50-60 Hz	
Input current on „1“ signal	3.3 mA (at 12 V DC, I1-I6), 1.1 mA (at 12 V DC, I7, I8)	3.3 mA (at 24 V DC, I6-I7), 2.2 mA (at 24 V DC, I7, I8)	4 mA (at 24 V AC, 50 Hz, I1-I6), 2 mA (at 24 V AC, 50 Hz, I7,I8), 2 mA (at 24 V DC, I7, I8)	6x0.25 mA (at 115 V AC, 60 Hz, I1-I6), 6x0.5 mA (at 230 V AC, 50 Hz, I1-I6) 2x4 mA (at 115 V AC, 60 Hz, I7, I8), 2x6 mA (at 230 V AC, 50 Hz, I7, I8)
Time delay from „0“ to „1“	debounce ON	20 ms		80 ms (at 50 Hz), 66 ^{2/3} ms (at 60 Hz)
	debounce OFF	typ. 0.3 ms (I1-I6), typ. 0.35 ms (I7, I8)	typ. 0,25 ms (I1-I8)	20 ms (at 50 Hz), 16 ^{2/3} ms (at 60 Hz)
Time delay from „1“ to „0“	debounce ON	20 ms		80 ms (at 50 Hz, I1-I6), 66 ^{2/3} ms (at 60 Hz, I1-I6) 160 ms (at 50 Hz, I7, I8), 150 ms (at 60 Hz, I7, I8)
	debounce OFF	typ. 0.3 ms (I1-I6), typ. 0.15 ms (I7, I8)	-	20 ms (at 50 Hz, I1-I6), 16 ^{2/3} ms (at 60 Hz, I1-I6) 100 ms (at 50 Hz, I7, I8), 100 ms (at 60 Hz, I7, I8)
Cable length (unshielded)	100 m		-	-
Maximum cable length per input	-		40 m	40 m (I1-I6), 100 m (I7, I8)
Frequency counter	Number	2 (I3, I4)		-
	counting frequency	< 1 kHz		-
	pulse shape	square-wave		-
	pulse / pause ratio	1:1		-
Rapid counter inputs	Number	2 (I1, I2)		-
	counting frequency	< 1 kHz		-
	pulse shape	square-wave		-
	pulse / pause ratio	1:1		-
Cable length (shielded)	< 20 m		-	-
Input circuit - Analog inputs				
Number	2 (I7, I8)			-
Electrical isolation	from voltage supply	no		
	from the digital inputs	no		
	from the outputs	yes		
	from PC interface, memory module, CL-NET, CL-LINK	no		
Input type	DC voltage			-
Signal range	0-10 V DC			-
Resolution	analog	0.01 V		
	digital	0.01 V; 10 Bit (value 1-1023)		
Input impedance	11.2 kΩ			-
Accuracy of the actual value	two CL devices	±3 %		
	within one device	±2 %, ±0.12 V		
Conversion time analog/digital	Input delay ON	20 ms		
	Input delay OFF	each cycle		
Input current	< 1 mA			-
Cable length (shielded)	< 30 m			-

Logic relays CL-LMR..., CL-LMT.. Technical data / Input circuit - inputs

Data at $T_a = 25\text{ °C}$ and rated values, if nothing else indicated.

Type	CL-LMR.C...18DC1	CL-LMR.C...18DC2 CL-LMT.C...20DC2	CL-LMR.C...18AC1	CL-LMR.C...18AC2
Input circuit - Digital inputs	12 V DC	24 V DC	24 V AC	115 / 230 V AC
Number	12			
Inputs can be used as analog inputs	4 (I7, I8, I11, I12)			-
Indication of operational states	LCD-Display (if existing)			
Electrical isolation	no			
from voltage supply	no			
between digital inputs	no			
from the outputs	yes			
from PC interface, memory module, CL-NET, CL-LINK	no			yes
Rated operational voltage U_e	12 V DC	24 V DC	24 V AC	
U_e on „0“ signal	4 V DC (I1-I12)	< 5 V DC (I1-I12, R1-R12)	0-6 V AC (sinusoidal)	0-40 V AC (sinusoidal)
U_e on „1“ signal	8 V DC (I1-I12)	> 15 V DC (I1-I6, I9, I10) > 8 V DC (I7, I8, I11, I12)	> 9.5 V DC, 14-26.4 V AC (sinusoidal) (I1-I6, I9, I10) > 7 V AC (sinusoidal) (I7, I8, I11, I12)	79-264 V AC (sinusoidal)
Rated frequency	-		50-60 Hz	
Input current on „1“ signal	3.3 mA (at 12 V DC, I1-I6, I9-I12), 1.1 mA (at 12 V DC, I7, I8),	3.3 mA (at 24 V DC, I1-I6, I9, I10), 2.2 mA (at 24 V DC, I7, I8, I11, I12)	4 mA (at 24 V AC, 50 Hz, I1-I6, I9, I10), 2 mA (at 24 V AC, 50 Hz, I7, I8, I11, I12), 2 mA (at 24 V DC, I7, I8, I11, I12)	6x0.25 mA (at 115 V AC, 60 Hz, I1-I6), 6x0.5 mA (at 230 V AC, 50 Hz, I1-I6) 2x4 mA (at 115 V AC, 60 Hz, I7, I8), 2x6 mA (at 230 V AC, 50 Hz, I7, I8), 4x0.25 mA (at 115 V AC, 60 Hz, I9-I12), 4x0.5 mA (at 230 V AC, 50 Hz, I9-I12)
Time delay from „0“ to „1“	debounce ON	20 ms		80 ms (at 50 Hz), 66 ² / ₃ ms (at 60 Hz)
	debounce OFF	typ. 0.3 ms (I1-I6, I9, I10), typ. 0.35 ms (I7, I8, I11, I12)	typ. 0.25 ms	20 ms (at 50 Hz), 16 ² / ₃ ms (at 60 Hz)
Time delay from „1“ to „0“	debounce ON	20 ms		80 ms (at 50 Hz), 66 ² / ₃ ms (at 60 Hz)
	debounce OFF	typ. 0.4 ms (I1-I6, I9, I10), typ. 0.35 ms (I7, I8, I11, I12)	-	20 ms (at 50 Hz), 16 ² / ₃ ms (at 60 Hz)
Cable length (unshielded)	100 m			
Maximum cable length per input			max. 40 m, typ. 40 m (I9, I10)	typ. 40 m (I1-I6, I9-I12), typ. 100 m (I7, I8)
Frequency counter	number	2 (I3, I4)		-
	counting frequency	< 1 kHz		-
	pulse shape	square-wave		-
	pulse / pause ratio	1:1		-
Rapid counter inputs	number	2 (I1, I2)		-
	counting frequency	< 1 kHz		-
	pulse shape	square-wave		-
	pulse / pause ratio	1:1		-
Cable length (shielded)	< 20 m			
Input circuit - Analog inputs				
Number	4 (I7, I8, I11, I12)			-
Electrical isolation	no			
from voltage supply	no			
from the digital inputs	no			
from the outputs	yes			
from PC interface, memory module, CL-NET, CL-LINK	no			
Input type	DC voltage			
Signal range	0-10 V DC			
Resolution	analog	0.01 V		
	digital	0.01 V; 10 Bit (value 1-1023)		
Input impedance	11.2 k Ω			
Accuracy of the actual value	two CL devices	$\pm 3\%$		
	within one device	$\pm 2\%$, $\pm 0.12\text{ V}$		
Conversion time analog/digital	Input delay ON	20 ms		
	Input delay OFF	each cycle		
Input current	< 1 mA			
Cable length (shielded)	< 30 m			

Logic relays

CL-LER., CL-LET..

Technical data / Input circuit - inputs

Data at $T_a = 25\text{ °C}$ and rated values, if nothing else indicated.

Type	CL-LER.18DC2 CL-LET.20DC2	CL-LER.18AC2
Input circuit - Digital inputs	24 V DC	115 / 230 V AC
Number		12
Inputs can be used as analog inputs		-
Indication of operational states		-
Electrical isolation		
from voltage supply		no
between digital inputs		no
from the outputs		yes
from PC interface, memory module, CL-NET, CL-LINK		no
Rated operational voltage U_o	24 V DC	
U_o on „0“ signal	< 5 V DC (I1-I12, R1-R12)	0-40 V AC (sinusoidal)
U_o on „1“ signal	-	79-264 V AC (sinusoidal)
Rated frequency	-	50-60 Hz
Input current on „1“ signal	3.3 mA (at 24 V DC, R1-R12)	12x0.25 mA (at 115 V AC, 60 Hz, R1-R12), 12x0.5 mA (at 230 V AC, 50 Hz, R1-R12)
Time delay from „0“ to „1“		
debounce ON	20 ms	80 ms (at 50 Hz, I1-I12, R1-R12), 66 ² / ₃ ms (at 60 Hz, I1-I12, R1-R12)
debounce OFF	typ. 0.25 ms (R1-R12)	20 ms (at 50 Hz, I1-I12, R1-R12), 16 ² / ₃ ms (at 60 Hz, I1-I12, R1-R12)
Time delay from „1“ to „0“		
debounce ON	20 ms	80 ms (at 50 Hz, I1-I12, R1-R12), 66 ² / ₃ ms (at 60 Hz, I1-I12, R1-R12)
debounce OFF	-	20 ms (at 50 Hz, I1-I12, R1-R12), 16 ² / ₃ ms (at 60 Hz, I1-I12, R1-R12)
Cable length (unshielded)	100 m	-
Maximum cable length per input	-	typ. 40 m (I1-I6, I9-I12, R1-R12), typ. 100 m (I7, I8)

Logic relays

CL-LSR., CL-LMR., CL-LER..

Technical data / Output circuit - Relay outputs

Data at $T_a = 25\text{ °C}$ and rated values, if nothing else indicated.

Type		CL-LSR...	CL-LMR... CL-LER...	CL-LER.20
Output circuit - Relay outputs				
Number		4	6	2
Outputs in groups of		1		2
Parallel switching of outputs to increase capacity		not permissible		
Fusing of the output relay		circuit-breaker B16 or fuse 8 A (slow-acting)		
Electrical isolation	from voltage supply		yes	
	from the inputs		yes	
	from PC interface, memory module, CL-NET, CL-LINK		no	
	protective separation		300 V AC	
	basic isolation		600 V AC	
Mechanical lifetime		10x10 ⁶ switching cycles		
Rung	conventional thermal current (10 A UL)		8 A	
	recommended for load 12 V AC/DC		> 500 mA	
	short-circuit proof $\cos \varphi = 1$; characteristic B16 at 600 A		16 A	
	short-circuit proof $\cos \varphi = 0,5$ up to 0,7; characteristic B16 at 900 A		16 A	
	Rated impulse withstand voltage U_{im} contact-coil		6 kV	
	Rated operational voltage U_e		250 V AC	
Rated insulation voltage U_i			250 V AC	
Protective separation (EN 50178)	between coil and contact		300 V AC	
	between two contacts		300V AC	
Making capacity	AC15, 250 V AC, 3 A (600 ops./h)		300.000 switching cycles	
	DC13, L/R \leq 150 ms, 24 V DC, 1 A (500 ops./h)		200.000 switching cycles	
Breaking capacity	AC15, 250 V AC, 3 A (600 ops./h)		300.000 switching cycles	
	DC13, L/R \leq 150 ms, 24 V DC, 1 A (500 ops./h)		200.000 switching cycles	
Incandescent lamp load	1000 W at 230/240 V AC		25.000 switching cycles	
	500 W at 115/120 V AC		25.000 switching cycles	
Fluorescent lamp load	10 x 58 W at 230/240 V AC with electrical control gear		25.000 switching cycles	
	10 x 58 W at 230/240 V AC uncompensated		25.000 switching cycles	
	1 x 58 W at 230/240 V AC conventional compensated		25.000 switching cycles	
Switching frequency	mechanical operations		10x10 ⁶	
	switching frequency		10 Hz	
	resistive load / lamp load		2 Hz	
	inductive load		0.5 Hz	
UL/CSA				
Continuous current at 240 V			10 A AC	
Continuous current at 24 V			8 A DC	
AC	Utilization category (Control Circuit Rating Codes)		B 300 Light Pilot Duty	
	max. rated operational voltage		300 V AC	
	max. continuous thermal current $\cos \varphi = 1$ at B 300		5 A	
	max. making / breaking apparent power (Make/Break) $\cos \varphi \neq 1$ at B 300		3600/360 VA	
DC	Utilization category (Control Circuit Rating Codes)		R 300 Light Pilot Duty	
	max. rated operational voltage		300 V DC	
	max. continuous thermal current at R 300		1 A	
	max. making / breaking apparent power (Make/Break) at R 300		28/28 VA	

Logic relays

CL-LST., CL-LMT., CL-LET..

Technical data / Output circuit - Transistor outputs

Data at $T_a = 25\text{ °C}$ and rated values, if nothing else indicated.

Type	CL-LST...	CL-LMT...	CL-LET...
Output circuit - Transistor outputs			
Number	4	8	
Rated operational voltage U_o	24 V DC		
Operational voltage range	20.4-28.8 V DC		
Residual ripple	≤ 5 %		
Supply current	on „0“ signal	typ. 9 mA / max. 16 mA	typ. 18 mA / max. 32 mA
	on „1“ signal	typ. 12 mA / max. 22 mA	typ. 24 mA / max. 44 mA
Reverse voltage protection	yes (Attention: If supply voltage is reversed, applying voltage at the outputs, causes a short circuit.)		
Electrical isolation	from voltage supply	yes	
	from the inputs	yes	
	from PC interface, memory module, CL-NET, CL-LINK	-	
Rated operational current I_o on „1“ signal DC	max. 0.5 A		
Lamp load without R_v	5 W		
Residual current on „0“ signal per channel	< 0.1 mA		
Max. output voltage	on „0“ signal at external load < 10 MΩ	2.5 V	
	on „1“ signal at $I_o = 0.5\text{ A}$	$U = U_o - 1\text{ V}$	
Short-circuit protection	yes, thermal (analysis results from diagnosis input I16, I15; R15, R16)		
Short-circuit tripping current for $R_a \leq 10\text{ m}\Omega$	$0.7\text{ A} \leq I_o \leq 2\text{ A}$ per output		
Total short-circuit current	8 A	16 A	
Peak short-circuit current	16 A	32 A	
Thermal tripping	yes		
Max. switching frequency with constant resistive load $R_L < 100\text{ k}\Omega$ (depending on active channels and their load)	40.000 switching cycles/h		
Parallel connection of outputs with resistive load, inductive load with external suppressor, combination within one group	group 1: Q1-Q4	group 1: Q1-Q4, group 2: Q5-Q8	group 1: S1-S4, group 2: S5-S8
	number of outputs	max. 4	
	max. total current	2 A (Attention! Outputs must be actuated simultaneously and for the same length of time.)	
Indication of operational states of the outputs	LCD-Display (if existing)		
Inductive load ¹⁾ without external suppressor			
$T_{0.95} = 1\text{ ms}$, $R = 48\ \Omega$, $L = 16\text{ mH}$	utilization factor	0.25 g	
	duty time	100 %	
	max. switching frequency $f = 0,5\text{ Hz}$ (max. duty time = 50 %)	1500 switching cycles	
DC13, $T_{0.95} = 72\text{ ms}$, $R = 48\ \Omega$, $L = 1.15\text{ H}$	utilization factor	0.25 g	
	duty time	100 %	
	max. switching frequency $f = 0,5\text{ Hz}$ (max. duty time = 50 %)	1500 switching cycles	
$T_{0.95} = 15\text{ ms}$, $R = 48\ \Omega$, $L = 0.24\text{ H}$	utilization factor	0.25 g	
	duty time	100 %	
	max. switching frequency $f = 0,5\text{ Hz}$ (max. duty time = 50 %)	1500 switching cycles	
Inductive load ¹⁾ with external suppressor			
	demand factor	1 g	
	duty time	100 %	
	max. switching frequency max. duty time	depends on suppressor	

¹⁾ For inductive loading, without external suppression of the transistor outputs, the following applies:
 $T_{0.95}$ = time in ms, until 95 % of the steady-state current is achieved. $T_{0.95} = 3 \times T_{0.65} = 3 \times L/R$.

Data transfer rate in the CL-NET network: bus lengths of 40 m and over only attainable with cables with additional cross-section and connection adapter.

Logic relays

CL-LS., CL-LM., CL-LE..

Technical data / General data, ...

Data at $T_a = 25\text{ °C}$ and rated values, if nothing else indicated.

Type		CL-LSR..., CL-LST...	CL-LMR... CL-LMT.. CL-LET., CL-LER.18..	CL-LER.20 CL-LEC.CI000
General data				
Dimensions (W x H x D)		71.5 mm x 90 mm x 58 mm (2.81 inch x 3.54 inch x 2.28 inch)	107.5 mm x 90 mm x 58 mm (4.23 inch x 3.54 inch x 2.28 inch)	35.5 mm x 90 mm x 58 mm (1.40 inch x 3.54 inch x 2.28 inch)
Weight		0.2 kg (0.44 lb)	0.3 kg (0.66 lb)	0.07 kg (0.15 lb)
Mounting		DIN rail (IEC/EN 60715), 35 mm or screw mounting with fixing brackets CL-LAS.FD001 (accessories)		
Mounting position		horizontal / vertical		
Electrical connection				
Wire size	rigid	0.2-4 mm ² (22-12 AWG)		
	fine-strand with wire end ferrule	0.2-2.5 mm ² (22-12 AWG)		
Max. tightening torque		0.6 Nm		
Environmental data				
Ambient temperature range	operation	-25...+55 °C, cold acc. to IEC 60068-2-1, heat acc. to IEC 60068-2-2		
	storage	-40...+70 °C		
LCD-Display (clearly legible)		0...+55 °C		
Condensation		avoid condensation with suitable methods		
Humidity, no condensation (IEC/EN 60068-2-30)		5-95 %		
Air pressure (operation)		795-1080 hPa		
Degree of protection (IEC/EN 60529)		IP20		
Vibration (IEC/EN 60068-2-6)		10-57 Hz (constant amplitude 0.15 mm), 57-150 Hz (constant acceleration 2 g)		
Shock resistance (half-sine 15 g / 11 ms) (IEC/EN 60068-2-27)		18 Shocks		
Drop (IEC/EN 60068-2-31) height of fall		50 mm		
Free fall, packaged (IEC/EN 60068-2-32)		1 m		
Insulation data				
Overvoltage category		II		
Pollution degree (DIN EN 60947)		2		
Rating of air and creepage distances		EN 50178, UL 508, CSA C22.2, No. 142		
Insulation resistance		EN 50178		
Standards				
Standards and directives		EN 55011, EN 55022, IEC/EN 61000-4, IEC 60068-2-6, IEC 60068-2-27		
Electromagnetic compatibility				
Interference immunity				
electrostatic discharge (ESD)	IEC/EN 61000-4-2	Level 3 (air discharge 8 kV, contact discharge 6 kV)		
electromag. field (HF radiation resistance)	IEC/EN 61000-4-3	10 V/m		
fast transients (Burst)	IEC/EN 61000-4-4	Level 3 (supply cable 2 kV, signal lines 2 kV)		
powerful impulses (Surge)	IEC/EN 61000-4-5	supply cable symmetrical (AC) 2 kV, Level 2 (supply cable symmetrical (DC) 0.5 kV)		
HF line emission	IEC/EN 61000-4-6	10 V		
Interference suppression (EN 55011, EN 55022)		class B		
Real time clock				
Back-up time		see diagram		-
Accuracy		typ. ± 5 (± 0.5 h/year)		-
Repeat accuracy of the time relay				
Accuracy (from value)		± 1		-
Resolution	range „S“	10 ms		-
	range „M:S“	1 s		-
	range „H:M“	1 min		-
Retention behaviour				
Write cycles of retention memory (minimum)		1.000.000 (10 ⁶)		-

Technical diagram

Back-up time of the real time clock

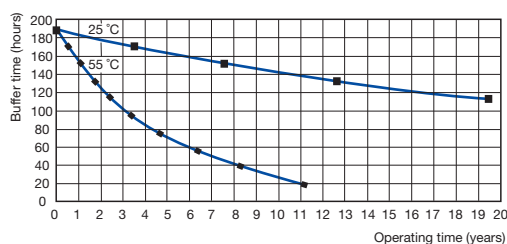

2CDC 312 023 F0206

Display system

Displays - CL-LDD..

Technical data

Data at $T_a = 25\text{ °C}$ and rated values, if nothing else indicated.

Type	CL-LDD...	
Input circuit - Supply circuit		
Power failure buffering (IEC/EN 61131-2)		10 ms
General data		
Dimensions (W x H x D)		with keypad: 86.5 x 86.5 x 21.5 mm (3.41 x 3.41 x 0.85 inch) without keypad: 86.5 x 86.5 x 20 mm (3.41 x 3.41 x 0.79 inch)
Weight		0.13 kg (0.29 lb)
Mounting		2 x 22.5 mm, with 2 retainers screwed
Mounting position		horizontal / vertical
Environmental data		
Ambient temperature range	operation	-25...+55 °C (cold acc. to IEC 60068-2-1, heat acc. to IEC 60068-2-2)
	storage	-40...+70 °C
LCD-Display (clearly legible)		-5...+50 °C, -10...0 °C (with backlit / continuous operation)
Condensation		avoid condensation with suitable methods
Humidity, no condensation (IEC/EN 60068-2-30)		5-95 %
Air pressure (operation)		795-1080 hPa
Degree of protection (IEC/EN 60529)		IP65
Vibration (IEC/EN 60068-2-6)		10-57 Hz (constant amplitude 0.15 mm), 57-150 Hz (constant acceleration 2 g)
Shock resistance (half-sine 15 g / 11 ms) (IEC/EN 60068-2-27)		18 Shocks
Drop (IEC/EN 60068-2-31) height of fall		50 mm
Free fall, packaged (IEC/EN 60068-2-32)		1 m
Insulation data		
Pollution degree (DIN EN 60947)		3
Rating of air and creepage distances		EN 50178, UL 508, CSA 22.2, No 142
Insulation resistance		EN 50178
Standards		
Standards and directives		EN 61000-6-1, EN 61000-6-2, EN 61000-6-3, EN 61000-6-4, IEC 60068-2-6, IEC 60068-2-27
Electromagnetic compatibility		
Interference immunity		
electrostatic discharge (ESD)	IEC/EN 61000-4-2	Level 3 (air discharge 8 kV, contact discharge 6 kV)
electromag. field (HF radiation resistance)	IEC/EN 61000-4-3	10 V/m
fast transients (Burst)	IEC/EN 61000-4-4	Level 3 (supply cable 2 kV, signal lines 2 kV)
powerful impulses (Surge)	IEC/EN 61000-4-5	Level 3 (supply cable symmetrical 2 kV, CL-LDC.L...AC2) Level 2 (0.5 kV supply cable symmetrical, CL-LDC.L...AC2)
HF line emission	IEC/EN 61000-4-6	10 V
Interference suppression (EN 55011, EN 55022)		class B

Logic relay, display system

Remote disp. con. / Display base mod. CL-LDC..

Technical data

Data at $T_a = 25\text{ °C}$ and rated values, if nothing else indicated.

Type	CL-LDC.SDC2	CL-LDC.SAC2	CL-LDC.LDC2	CL-LCD.LAC2	CL-LDC.LNDC2	CL-LDC.LNAC2
Input circuit - Supply circuit						
Rated operational voltage U_g	24 V DC	100-240 V AC	24 V DC	100-240 V AC	24 V DC	100-240 V AC
Rated operational voltage tolerance	-15...+20 %	-15...+10 %	-15...+20 %	-15...+10 %	-15...+20 %	-15...+10 %
Operational voltage range	20.4-28.8 V DC	85-264 V AC	20.4-28.8 V DC	85-264 V AC	20.4-28.8 V DC	85-264 V AC
Frequency	0 Hz	50/60 Hz	0 Hz	50/60 Hz	0 Hz	50/60 Hz
Frequency tolerance	-	± 5 %	-	± 5 %	-	± 5 %
Residual ripple	≤ 5 %	-	≤ 5 %	-	≤ 5 %	-
Input current	10 ms					
at 24 V DC	typ. 185 mA	-	typ. 200 mA	-	typ. 200 mA	-
at 115/120 V AC (60 Hz)	-	typ. 90 mA	-	typ. 90 mA	-	typ. 90 mA
at 230/240 V AC (50 Hz)	-	typ. 60 mA	-	typ. 60 mA	-	typ. 60 mA
Power failure buffering (IEC/EN 61131-2)	10 ms					
Power dissipation	10 ms					
at 24 V DC	1.5 W	-	3.4 W	-	3.4 W	-
at 115/120 V AC	-	typ. 11 VA	-	typ. 11 VA	-	typ. 11 VA
at 230/240 V AC	-	typ. 15 VA	-	typ. 15 VA	-	typ. 15 VA
Network - point-to-point connection						
Number of stations	1		-			
Data transfer rate	CL-LS..., CL-LM...		9,6 kBaud		-	
	CL-LDD		19,2 kBaud		-	
Distance	max. 5 m		-			
Electrical isolation	to voltage supply		yes		-	
	to connected device		yes		-	
Termination system	spring-type terminal		-			
Network - CL-NET						
Number of stations	max. 1		-		max. 8	
Data transfer rate	6 m		-		1000 kBit/s	
	25 m		-		500 kBit/s	
	40 m		-		250 kBit/s	
	125 m		-		125 kBit/s	
	300 m		-		50 kBit/s	
	700 m		-		20 kBit/s	
	1000 m		-		10 kBit/s	
Electrical isolation	to voltage supply		-		yes	
	to inputs		-		yes	
	to outputs		-		yes	
	to PC interface, memory module, CL-NET, CL-LINK		-		yes	
Bus terminator (first and last station)	-		-		yes	
Termination system	-		-		RJ45, 8 pole	
General data						
Dimensions (W x H x D)	75 x 58 x 36.2 mm (2.95 x 2.28 x 1.43 inch)		107.5 x 90 x 30 mm (4.23 x 3.54 x 1.18 inch)			
Weight	0.164 kg (0.36 lb)		0.145 kg (0.32 lb)			
Mounting	plugged onto CL-LDD		plugged onto CL-LDD or on DIN rail (IEC/EN 60715)			
Mounting position						
Electrical connection - Supply circuit						
Wire size	fine-strand with wire end ferrule		0.2 mm ² / 2.5 mm ² (24-12 AWG)			
	rigid		0.2 mm ² / 4 mm ² (24-12 AWG)			
Electrical connection - Data cable						
Wire size	fine-strand with wire end ferrule		0.08 mm ² / 1.5 mm ² (28-12 AWG)		0.2 mm ² / 2.5 mm ² (24-12 AWG)	
	rigid		0.08 mm ² / 2.5 mm ² (28-12 AWG)		0.2 mm ² / 4 mm ² (24-12 AWG)	
Environmental data						
Ambient temperature range	operation		-25...+55 °C (cold acc. to IEC 60068-2-1, heat acc. to IEC 60068-2-2)			
	storage		-40...+70 °C			
Condensation	avoid condensation with suitable methods					
Humidity, no condensation (IEC/EN 60068-2-30)	5-95 %					
Air pressure (operation)	795-1080 hPa					
Degree of protection (IEC/EN 60529)	IP20					
Vibration (IEC/EN 60068-2-6)	10-57 Hz (constant amplitude 0.15 mm), 57-150 Hz (constant acceleration 2 g)					

Logic relay, display system

Remote disp. con. / Display base mod. CL-LDC..

Technical data (continued)

Data at $T_a = 25\text{ °C}$ and rated values, if nothing else indicated.

Type	CL-LDC.SDC2	CL-LDC.SAC2	CL-LDC.LDC2	CL-LCD.LAC2	CL-LDC.LNDC2	CL-LDC.LNAC2
Shock (half-sine 15 g / 11 ms) (IEC/EN 60068-2-27)	18 Shocks					
Drop (IEC/EN 60068-2-31) height of fall	50 mm					
Free fall, packaged (IEC/EN 60068-2-32)	1 m					
Insulation data						
Degree of protection (DIN EN 60947)	2					
Rating of air and creepage distances	EN 50178, UL 508, CSA 22.2, No 142					
Isolation resistance	EN 50178					
Standards						
Standards and directives	EN 61000-6-1, EN 61000-6-2, EN 61000-6-3, EN 61000-6-4, IEC 60068-2-6, IEC 60068-2-27					
Electromagnetical compatibility						
Interference immunity						
electrostatic discharge (ESD)	IEC/EN 61000-4-2	Level 3 (air discharge 8 kV, contact discharge 6 kV)				
electromag. field (HF radiation resistance)	IEC/EN 61000-4-3	10 V/m				
fast transients (Burst)	IEC/EN 61000-4-4	Level 3 (supply cable 2 kV, signal lines 2 kV)				
powerful impulses (Surge)	IEC/EN 61000-4-5	Level 3 (supply cable symmetrical 2 kV, CL-LDC.L...AC2)				
		Level 2 (1 kV supply cable symmetrical)	Level 2 (0.5 kV supply cable symmetrical, CL-LDC.L...AC2)			
HF line emission	IEC/EN 61000-4-6	10 V				
Interference suppression (EN 55011, EN 55022)	class B					
Real time clock						
Back-up time	-	see diagram				
Accuracy	-	typ. ± 5 s/day ($\pm 0,5$ h/year)				
Repeat accuracy of the time relay						
Accuracy (from value)	-	$\pm 0.02\%$				
Resolution	range „S“	-	5 ms			
	range „M:S“	-	1 s			
	range „H:M“	-	1 min			
Retention behaviour						
Write cycles of retention memory (minimum)	-	10^{10} (read/ write cycles)				

Technical diagram

Back-up time of the real time clock

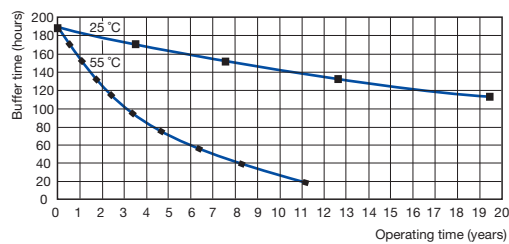

2CDC 312 023 F0206

Display system

Display I/O-modules - CL-LDR., CL-LDT..

Technical data

Data at $T_a = 25\text{ °C}$ and rated values, if nothing else indicated.

Type	CL-LD...16DC2	CL-LD...17DC2	CL-LDR.16AC2
Input circuit - Digital inputs			
		24 V DC	
		115/230 V	
Number	12		
Inputs can be used as analog inputs	4 (I7, I8, I11, I12)		-
Indication of operational states	-		LCD-Display (if existing)
Electrical isolation	from supply voltage	no	
	from digital inputs	no	
	from the outputs	yes	
	from PC interface, memory module, CL-NET, CL-LINK	yes	
Rated operational voltage U_o	24 V DC		-
	U_o on „0“ signal	< 5 V DC (I1-I6, I9, I10), < 8 V DC (I7, I8, I11, I12)	
	U_o on „1“ signal	> 15 V DC (I1-I6, I9, I10), > 8 V DC (I7, I8, I11, I12)	
Rated frequency	0 Hz		50-60 Hz
Input current on „1“ signal	3.3 mA (at 24 V DC, I1-I6, I9, I10), 2.2 mA (at 24 V DC, I7, I8, I11, I12)		12x0.2 mA (at 115 V AC, 60 Hz, I1-I12), 12x0.5 mA (at 230 V AC, 50 Hz, I1-I12)
Time delay from „0“ to „1“	debounce ON	20 ms	
	debounce OFF	typ. 0.1 ms (I1-I4), typ. 0.25 ms (I5-I12)	
Time delay from „1“ to „0“	debounce ON	20 ms	
	debounce OFF	typ. 0.1 ms (I1-I4), typ. 0.4 ms (I5, I6, I9, I10), typ. 0.2 ms (I7, I8, I11, I12)	
Cable length (unshielded)	100 m		-
Maximum cable length per input	-		typ. 60 m
Frequency counter	number	4 (I1, I2, I3, I4)	
	counting frequency	< 3 kHz	
	pulse shape	square-wave	
	pulse / pause ratio	1:1	
Incremental counter	number	2 (I1 + I2, I3 + I4)	
	counting frequency	< 3 kHz	
	pulse shape	square-wave	
	signal offset	90°	
	pulse / pause ratio	1:1	
Rapid counter inputs	number	4 (I1, I2, I3, I4)	
	counting frequency	< 3 kHz	
	pulse shape	square-wave	
	pulse / pause ratio	1:1	
Cable length (shielded)	< 20 m		-
Input circuit - Analog inputs			
Number	4 (I7, I8, I11, I12)		
Electrical isolation	to voltage supply	no	
	to digital inputs	no	
	to outputs	yes	
	to PC interface, memory modul, CL-NET, CL-LINK	yes	
Input type	DC voltage		
Signal range	0-10 V DC		
Resolution	analog	0.01 V	
	digital	0.01 V; 10 Bit (value 0-1023)	
Input impedance	11.2 kΩ		
Accuracy of the actual value	two CL-LD... devices	± 3 %	
	within one device	± 2 %	
Conversion time analog/digital	each cycle		
Input current	< 1 mA		
Cable length (shielded)	< 30 m		

Display system

Display I/O-modules - CL-LDR., CL-LDT..

Technical data (continued)

Data at $T_a = 25\text{ °C}$ and rated values, if nothing else indicated.

Type		CL-LD...16DC2	CL-LD...17DC2	CL-LDR.16AC2
Output circuit - Analog outputs				
Number		-	1	-
Electrical separation	from voltage supply	-	no	-
	from the digital inputs	-	no	-
	from the digital outputs	-	yes	-
	from PC interface, memory module, CL-NET, CL-LINK	-	yes	-
Output type		-	DC voltage	-
Signal range		-	0-10 V DC	-
Max. output current		-	0.01 A	-
Burden resistance		-	1 k Ω	-
Overload and short-circuit protection		-	yes	-
Resolution	analog	-	0.01 V DC	-
	digital	-	10 Bit, (value: 0-1023)	-
Setting time		-	100 ms	-
Accuracy	-25...+55 °C	-	2 %	-
	25 °C	-	1 %	-
Conversion time		-	each CPU cycle	-
General data				
Dimensions (W x H x D)		CL-LDR: 89 x 90 x 44 mm (3.5 x 3.54 x 1.73 inch) CL-LDT (build-in): 89 x 90 x 25 mm (3.5 x 3.54 x 0.98 inch)		89 x 90 x 44 mm (3.5 x 3.54 x 1.73 inch)
Weight		CL-LDR: 0.15 kg (0.33 lb) / CL-LDT: 0.14 kg (0.31 lb)		0.15 kg (0.33 lb)
Mounting		snap-on power supply unit		
Mounting position		horizontal / vertical		
Electrical connection				
Wire size	fine-strand with wire end ferrule	0.2 mm ² / 2.5 mm ² (24-12 AWG)		
	rigid	0.2 mm ² / 4 mm ² (24-12 AWG)		
Electrical connection - Data cable				
Wire size	fine-strand with wire end ferrule	0.08 mm ² / 1.5 mm ² (28-12 AWG)		
	rigid	0.08 mm ² / 2.5 mm ² (28-12 AWG)		
Environmental data				
Ambient temperature range	operation	-25...+55 °C (cold acc. to IEC 60068-2-1, heat acc. to IEC 60068-2-2)		
	storage	-40...+70 °C		
Condensation		avoid condensation with suitable methods		
Humidity, no condensation (IEC/EN 60068-2-30)		5-95 %		
Atmospheric pressure (operation)		795-1080 hPa		
Degree of protection (IEC/EN 60529)		IP20		
Vibration (IEC/EN 60068-2-6)		10-57 Hz (constant amplitude 0.15 mm), 57-150 Hz (constant acceleration 2 g)		
Shock (half-sine 15 g / 11 ms) (IEC/EN 60068-2-27)		18 Shocks		
Drop (IEC/EN 60068-2-31) height of fall		50 mm		
Free fall, packaged (IEC/EN 60068-2-32)		1 m		
Insulation data				
Pollution degree		2		
Rating of air and creepage distances		EN 50178, UL 508, CSA C22.2, No. 142		
Isolation resistance		EN 50178		
Standards				
Standards and directives		EN 61000-6-1/-2/-3/-4, IEC/EN 61000-4, IEC 60068-2-6, IEC 60068-2-27		
Electromagnetic compatibility				
electrostatic discharge (ESD)	IEC/EN 61000-4-2	Level 3 (air discharge 8 kV, contact discharge 6 kV)		
electromag. field (HF radiation res.)	IEC/EN 61000-4-3	10 V/m		
fast transients (Burst)	IEC/EN 61000-4-4	Level 3 (supply cable 2 kV, signal cable 2 kV)		
powerful impulses (Surge)	IEC/EN 61000-4-5	2 kV (supply cable symmetrical), Level 2 (0.5 kV supply cable symmetrical)		
HF line emission	IEC/EN 61000-4-6	10 V		
Interference suppression (EN 55011, EN 55022)		class B		

Display system

Display I/O-modules - CL-LDR..

Technical data / Output circuit - Relay outputs

Data at $T_a = 25\text{ °C}$ and rated values, if nothing else indicated.

Type		CL-LDR...
Output circuit - Relay outputs		
Number		4
Outputs in groups of		-
Parallel switching of outputs to increase capacity		not permissible
Fusing of the output relay		circuit-breaker B16 or fuse 8 A (slow-acting)
Electrical isolation	from voltage supply	yes
	from the inputs	yes
	from PC interface, memory module, CL-NET, CL-LINK	yes
	protective separation	300 V AC
	Basic isolation	600 V AC
Mechanical lifetime		10×10^6 switching cycles
Rung	conventional thermal current (10 A UL)	8 A
	recommended load 12 V AC/DC	> 500 mA
	short-circuit proof $\cos \varphi = 1$; characteristic B16 at 600 A	16 A
	short-circuit proof $\cos \varphi = 0.5$ up to 0.7; characteristic B16 at 900 A	16 A
	Rated impulse withstand voltage U_{imp} contact-coil	6 kV
	Rated operational voltage U_o	250 V AC
Rated insulation voltage U_i		250 V AC
Protective separation (EN 50178)	between coil and contact	300 V AC
	between two contacts	300V AC
Making capacity	AC15, 250 V AC, 3 A (600 ops./h)	300.000 switching cycles
	DC13, L/R \leq 150 ms, 24 V DC, 1 A (500 ops./h)	200.000 switching cycles
Breaking capacity	AC15, 250 V AC, 3 A (600 ops./h)	300.000 switching cycles
	DC13, L/R \leq 150 ms, 24 V DC, 1 A (500 ops./h)	200.000 switching cycles
Incandescent lamp load	1000 W at 230/240 V AC	25.000 switching cycles
	500 W at 115/120 V AC	25.000 switching cycles
Fluorescent lamp load	10 x 58 W at 230/240 V AC with electrical control gear	25.000 switching cycles
	10 x 58 W at 230/240 V AC uncompensated	25.000 switching cycles
	1 x 58 W at 230/240 V AC conventional compensated	25.000 switching cycles
Switching frequency	mechanical operations	10×10^6
	switching frequency	10 Hz
	resistive load / lamp load	2 Hz
	inductive load	0.5 Hz
UL/CSA		
Continuous current at 240 V		10 A AC
Continuous current at 24 V		8 A DC
AC	Utilization category (Control Circuit Rating Codes)	B 300 Light Pilot Duty
	max. rated operational voltage	300 V AC
	max. continuous thermal current $\cos \varphi = 1$ at B 300	5 A
	max. making / breaking apparent power (Make/Break) $\cos \varphi \neq 1$ at B 300	3600/360 VA
DC	Utilization category (Control Circuit Rating Codes)	R 300 Light Pilot Duty
	max. rated operational voltage	300 V DC
	max. continuous thermal current at R 300	1 A
	max. making / breaking apparent power (Make/Break) at R 300	28/28 VA

Display system

Display I/O-modules - CL-LDT..

Technical data / Output circuit - Transistor outputs

Data at $T_a = 25\text{ °C}$ and rated values, if nothing else indicated.

Type	CL-LDT...
Output circuit - Transistor outputs	
Number	4
Rated operational voltage U_o	24 V DC
Operational voltage range	20.4-28.8 V DC
Residual ripple	-
Supply current	on „0“ signal typ. 18 mA / max. 32 mA on „1“ signal typ. 24 mA / max. 44 mA
Reverse voltage protection	yes (Attention: If supply voltage is reversed, applying voltage at the outputs, causes a short circuit.)
Electrical isolation	from voltage supply yes from the inputs yes from PC interface, memory module, CL-NET, CL-LINK yes
Rated operational current I_o on „1“ signal DC	max. 0.5 A
Lamp load without R_v	5 W (Q1-Q4)
Residual current on „0“ signal per channel	< 0.1 mA
Max. output voltage	on „0“ signal at external load < 10 M Ω 2.5 V on „1“ signal at $I_o = 0.5\text{ A}$ $U = U_o - 1\text{ V}$
Short-circuit protection	thermal (Q1-Q4), (analysis results from diagnosis input I16)
Short-circuit tripping current for $R_s \leq 10\text{ m}\Omega$	$0.7\text{ A} \leq I_o \leq 2\text{ A}$ per output
Total short-circuit current	8 A
Peak short-circuit current	16 A
Thermal tripping	yes
Max. switching frequency with constant resistive load $R_L < 100\text{ k}\Omega$ (depending on active channels and their load)	40.000 switching cycles/h
Parallel connection of outputs	with resistive load, inductive load with external suppressor, combination within one group group 1: Q1-Q4
number of outputs	max. 4
max. total current	2 A (Attention! Outputs must be actuated simultaneously and for the same length of time.)
Indication of operational states of the outputs	LCD-Display (if existing)
Inductive load¹⁾ without external suppressor	
$T_{0.95} = 1\text{ ms}$, $R = 48\ \Omega$, $L = 16\text{ mH}$	utilization factor 0.25 g duty time 100 % max. switching frequency $f = 0.5\text{ Hz}$ (max. duty time = 50 %) 1500 switching cycles
DC13, $T_{0.95} = 72\text{ ms}$, $R = 48\ \Omega$, $L = 1.15\text{ H}$	utilization factor 0.25 g duty time 100 % max. switching frequency $f = 0.5\text{ Hz}$ (max. duty time = 50 %) 1500 switching cycles
$T_{0.95} = 15\text{ ms}$, $R = 48\ \Omega$, $L = 0.24\text{ H}$	utilization factor 0.25 g duty time 100 % max. switching frequency $f = 0.5\text{ Hz}$ (max. duty time = 50 %) 1500 switching cycles
Inductive load¹⁾ with external suppressor	
	demand factor 1 g duty time 100 % max. switching frequency max. duty time depends on suppressor

¹⁾ For inductive loading, without external suppression of the transistor outputs, the following applies:

$T_{0.95}$ = time in ms, until 95 % of the steady-state current is achieved. $T_{0.95} \cdot 3 \times T_{0.65} = 3 \times L/R$.

Data transfer rate in the CL-NET network: bus lengths of 40 m and over only attainable with cables with additional cross-section and connection adapter.

Logic relays, display system

CL range

Dimensional drawings

Dimensional drawings

dimensions in mm

CL-LSR, CL-LST

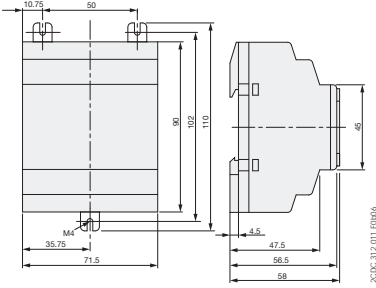

CL-LMR, CL-LMT

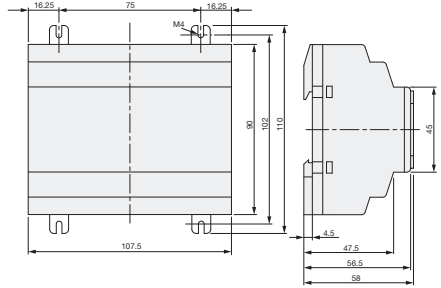

CL-LER.20

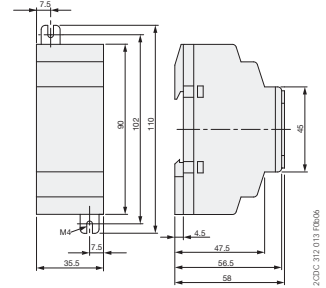

CL-LDD

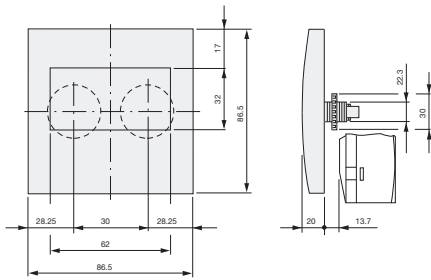

**CL-LDD.K + CL-LDC.L.. +
(CL-LDR or CL-LDT)**

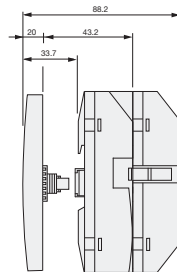
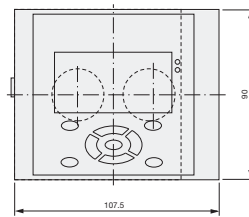

CL-LDC.S..

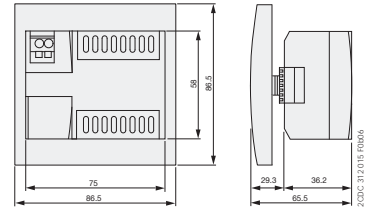

CL-LDR, CL-LDT

