

Ball Screw Brake

The Nexen Ball Screw Brake is a high-torque, spring-engaged brake acting on the machined end of a ball screw. It serves as a primary or redundant safety brake to prevent back driving if a power loss or mechanical defect occurs in the driveline.

The low backlash and coupling combination provides a high degree of accuracy for holding ball screw position. An expanding shaft/clamping hub coupling connects the brake shaft to the end of the ball screw. This coupling comes with an elastomer insert with high torsional stiffness.

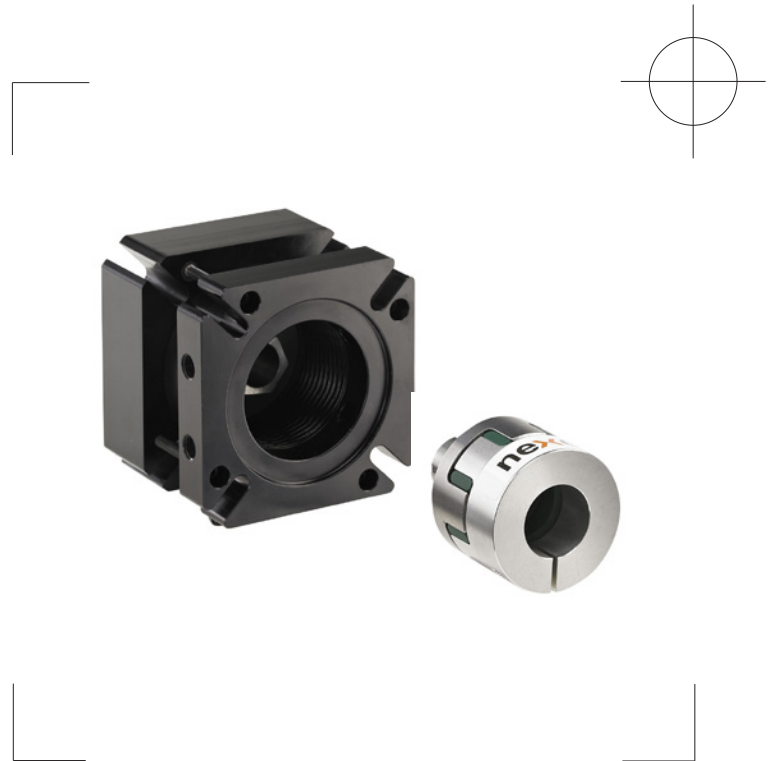

Features

- Low backlash for precision holding
- Spring engaged, air released
- Low inertia
- High torsional rigidity
- Bi-directional braking
- Fast engagement
- Meets IP67 dust and waterproof standards
- Operates in vertical and horizontal applications
- Allows thermal expansion of ball screw

Brake Dimensions

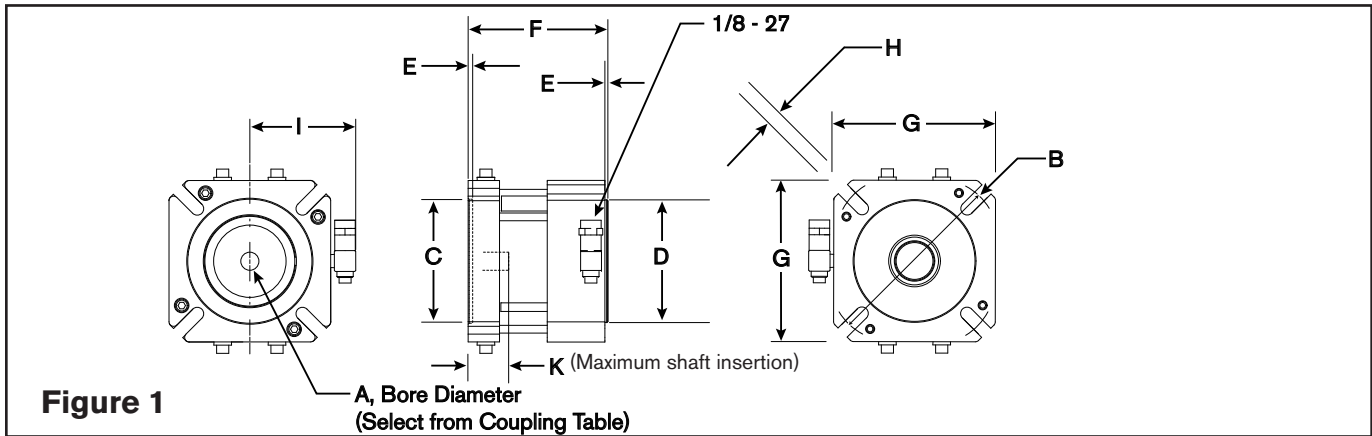

Model Size	Product Numbers	A (Bore Range)	B	C	D	E	F	G	H	I	K
BSB 2	964640	5-12,7 [0.197-0.50]	63-91,5 [2.48-3.60]	52 [2.047]	50 [1.97]	3,50 [0.14]	74,5 [2.93]	74,2 [2.92]	6,3 [0.24]	56 [2.20]	12 [0.5]
BSB 3	964745 964740 ¹	7-16 [0.275-0.63]	95-108 [3.74-4.25]	50 [1.97]	50 [1.97]	5,00 [0.20]	77,7 [3.06]	92 [3.62]	7 [0.28]	65 [2.56]	18.5 [0.73]
BSB 4	964840	16-32 [0.63-1.26]	115-150 [4.53-5.91]	96 [3.78]	95 [3.74]	3,50 [0.14]	105,7 [4.16]	125 [4.92]	10 [0.39]	82 [3.23]	24.2 [0.95]
BSB 5	964940	16-32 [0.63-1.26]	165-186 [6.49-7.32]	130 [5.12]	130 [5.12]	6,15 [0.24]	132,5 [5.22]	150,4 [5.92]	12 [0.47]	95 [3.74]	25.5 [1.00]
BSB 7	965040	20-35 [0.787-1.38]	215 [8.47]	130 [5.12]	130 [5.12]	3,50 [0.14]	105,8 [4.17]	192 [7.56]	15* [0.59]	113 [4.45]	29.1 [1.14]

¹ Torque = 5 Nm (44 in-lbs)

* Clearance Hole Diameter

NOTE: When selecting a brake, a coupling must also be selected. See the coupling chart on the next page.

Brake Specifications

Model Size	Minimum Holding Torque	Release Pressure	Maximum Speed (RPM)	Inertia / Coupling kg.m ² [lbs-ft ²]	Torsional Rigidity Nm/radian [lb-ft/radian]	Weight
BSB 2	2 Nm [20 in-lbs]	5.5 bar [80 psi]	10,000	0,00002 [0.0005]	6180 [4550]	1,3 kg [2.9 lbs]
BSB 3	8 Nm [70 in-lbs]	5.5 bar [80 psi]	10,000	0,00006 [0.0014]	9613 [7090]	1,6 kg [3.5 lbs]
BSB 4	22 Nm [200 in-lbs]	5.5 bar [80 psi]	10,000	0,00031 [0.00736]	23796 [17550]	3,4 kg [7.6 lbs]
BSB 5	45 Nm [400 in-lbs]	5.5bar [80 psi]	10,000	0,00114 [0.0271]	36184 [26688]	6,6 kg [14.6 lbs]
BSB 7	125 Nm [1100 in-lbs]	5.5 bar [80 psi]	5,000	0,00394 [0.0935]	54772 [40390]	14,7 kg [32.4 lbs]

Coupling Specifications

BSB Brake Model	Coupling Product Number	Bore (H7)	Coupling Bore Range	Axial Misalignment	Torsional Rigidity Nm/radian [ft-lb/radian]
BSB2	964641	8 mm	5-12.7 mm (0.197-0.500")	+/- 1 mm (+/- 0.04")	350 (258)
BSB2	964642	0.406	5-12.7 mm (0.197-0.500")	+/- 1 mm (+/- 0.04")	350 (258)
BSB3	964741	14 mm	7-16 mm (0.275-0.625")	+/- 1 mm (+/- 0.04")	600 (442)
BSB3	964742	0.500	7-16 mm (0.275-0.625")	+/- 1 mm (+/- 0.04")	600 (442)
BSB3	964743	0.312	7-16 mm (0.275-0.625")	+/- 1 mm (+/- 0.04")	600 (442)
BSB3	964744	0.625	7-16 mm (0.275-0.625")	+/- 1 mm (+/- 0.04")	600 (442)
BSB4 and BSB5	964841	20 mm	16-32 mm (0.630-1.250")	+/- 2 mm (+/- 0.08")	9750 (7191)
BSB4 and BSB5	964847	20 mm, keyed	16-32 mm (0.630-1.250")	+/- 2 mm (+/- 0.08")	9750 (7191)
BSB4 and BSB5	964868	0.875	16-32 mm (0.630-1.250")	+/- 2 mm (+/- 0.08")	9750 (7191)
BSB4 and BSB5	964854	1.000	16-32 mm (0.630-1.250")	+/- 2 mm (+/- 0.08")	9750 (7191)
BSB4 and BSB5	964859	23 mm	16-32 mm (0.630-1.250")	+/- 2 mm (+/- 0.08")	9750 (7191)
BSB4 and BSB5	964862	19 mm	16-32 mm (0.630-1.250")	+/- 2 mm (+/- 0.08")	9750 (7191)
BSB4 and BSB5	964863	1.125	16-32 mm (0.630-1.250")	+/- 2 mm (+/- 0.08")	9750 (7191)
BSB7	965041	30 mm	20-35 mm (0.787-1.375")	+/- 2 mm (+/- 0.08")	10600 (7818)
BSB7	965042	35 mm	20-35 mm (0.787-1.375")	+/- 2 mm (+/- 0.08")	10600 (7818)
BSB7	965043	1.000	20-35 mm (0.787-1.375")	+/- 2 mm (+/- 0.08")	10600 (7818)
BSB7	965044	20 mm	20-35 mm (0.787-1.375")	+/- 2 mm (+/- 0.08")	10600 (7818)
BSB7	965045	25 mm	20-35 mm (0.787-1.375")	+/- 2 mm (+/- 0.08")	10600 (7818)
BSB7	965046	1.375	20-35 mm (0.787-1.375")	+/- 2 mm (+/- 0.08")	10600 (7818)

Note: Select a coupling with a bore matching the machined end of the ball screw. Custom bores available on request; see Bore Range. Keyed bores optional.

Back Drive Torque Formula

In-lbs

$$\text{Back Drive Torque} = \frac{PLe}{2(\pi)}$$

L = Screw Lead in inches
P = Load in pounds
e = mechanical efficiency of 0.9
 $\pi = 3.1416$

Nm

$$\text{Back Drive Torque} = \frac{LPe}{2000(\pi)}$$

L = Screw Lead in millimeter
P = Load in Newtons
e = mechanical efficiency (0.9)
 $\pi = 3.1416$

Note: Select a Ball Screw Brake with holding torque that exceeds the back-drive torque by 20-30%.

Brake Control

3-Way Valve, Air Inlet Mount

Product Number	964650
Valve	Normally Closed
Effective Orifices	0.062 Body 0.089 Exhaust Port
Port Size	1/8-27 NPT Male
Voltage	24VDC
DIN Connector	Included
Power Consumption	25 Watts

In accordance with Nexen's established policy of constant product improvement, the specifications contained in this document are subject to change without notice. Technical data listed in this document are based on the latest information available at the time of printing and are also subject to change without notice. For current information, please consult www.nexengroup.com

nexen[®]

Nexen Group, Inc.
560 Oak Grove Parkway
Vadnais Heights, MN 55127

800.843.7445
Fax: 651.286.1099
www.nexengroup.com

Nexen has sales offices throughout the United States, Europe, Japan, and Australia.