

Platform Cylinder

Series CXT

ø12, ø16, ø20, ø25, ø32, ø40

A highly rigid and highly accurate slide table integrated with an actuator.

■ Two styles of guide rod bearings to accommodate your application

Slide bearing — For heavy loads

Ball bushing bearing — For highly accurate and smooth operation

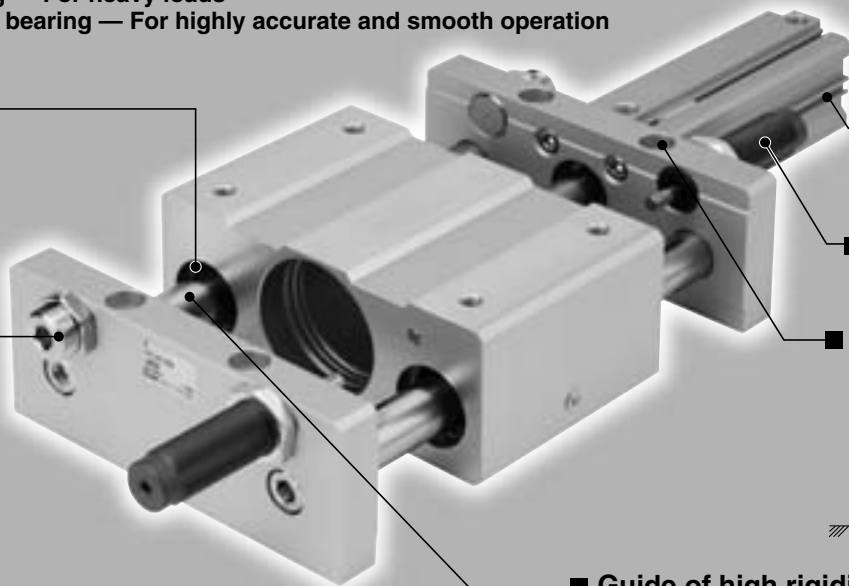

■ Auto switch can be mounted.

■ A shock absorber can be installed (option).

■ Can be mounted on two sides.

Mounting from the upper side Mounting from the bottom side

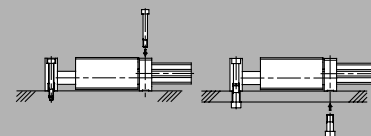

■ Guide of high rigidity

■ Adjusting bolt with bumper is standard.

Performs the function of a cushion and adjusts the stroke 5 mm on each side, or 10 mm for both sides.

For moving and transferring workpieces.

For moving the receptacle for workpieces used in stamping or press-fitting processes.

For using as a Pick & Place unit in combination with other actuators.

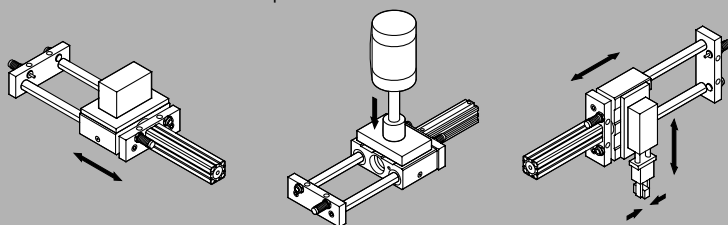

Series	Maximum load mass (kg)	CXTM (Slide bearing)		CXTL (Ball bushing bearing)	
		Table ⁽¹⁾ displacement (mm)	Allowable ⁽²⁾ static mass (kg)	Table ⁽¹⁾ displacement (mm)	Allowable ⁽²⁾ static mass (kg)
CXT□12	3	0.002	350	0.015	60
CXT□16	7	0.004	500	0.019	70
CXT□20	12	0.007	900	0.044	125
CXT□25	20	0.030	900	0.180	125
CXT□32	30	0.032	1100	0.123	140
CXT□40	50	0.025	1900	0.109	170

Note 1) Table displacement

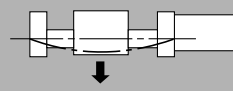

"Table displacement" is the amount of deflection of the guide rod that occurs when a maximum load mass is placed on the maximum stroke table while the table is at the center of the stroke (the amount of looseness is not included).

Note 2) Allowable static mass

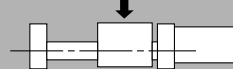

An "allowable stationary mass" is the allowable amount of stationary mass that can be applied vertically to the workpiece mounting surface of the table while the table is at the stroke end.

■ Series Variations

Bearing type		Bore size (mm)	Stroke (mm)										
Slide bearing	Ball bushing bearing		15	25	50	75	100	125	150	175	200	250	300
CXTM12	CXTL12	12	●	●	○	○	○						
CXTM16	CXTL16	16	●	●	○	○	○						
CXTM20	CXTL20	20		●	●	○	○	○	○	○	○	○	○
CXTM25	CXTL25	25			●	●	○	○	○	○	○	○	○
CXTM32	CXTL32	32				●	●	○	○	○	○	○	○
CXTM40	CXTL40	40					●	●	○	○	○	○	○

●Standard stroke ○Long stroke

CX2

CXW

CXT

CXSJ

CXS

D-□

-X□

Individual
-X□

Series CXT Model Selection

Selection Step

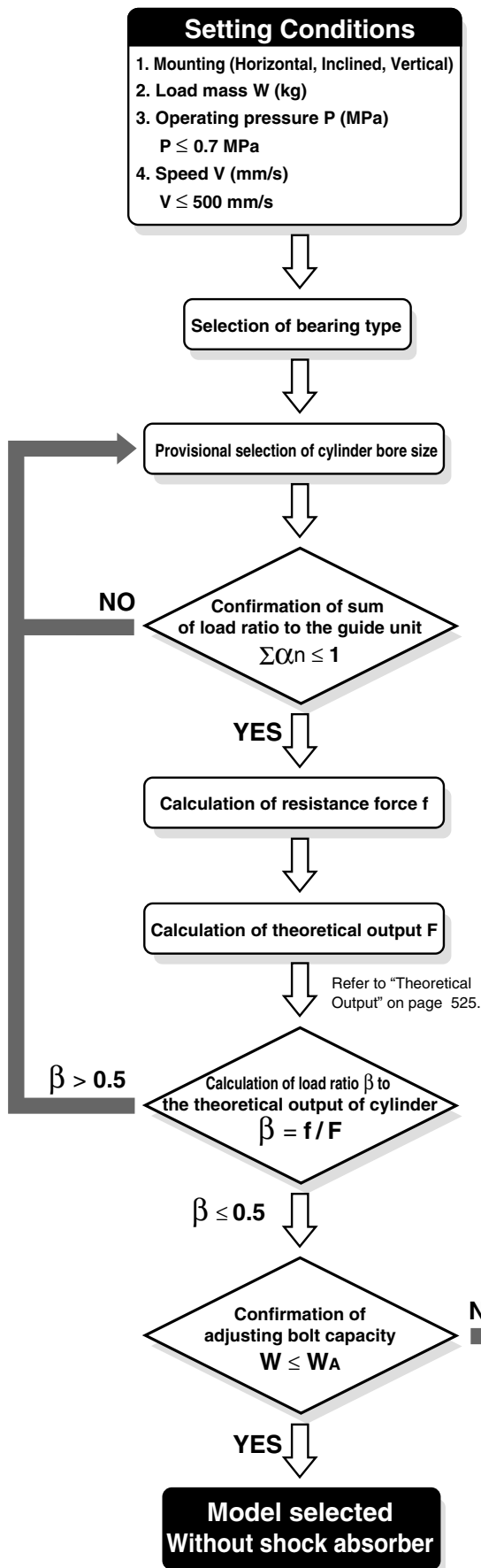

Guideline for Selection of Bearing Type

Bearing type	Required conditions
Slide bearing	<ul style="list-style-type: none"> • Impact load and vibration load are added. • Change in load is large. • Long life span is required.
Ball bushing bearing	<ul style="list-style-type: none"> • High accuracy (Little rattle is allowed.) • Smooth operation

$$\sum \alpha \cdot n = \frac{\text{Load mass [W]}}{\text{Maximum load mass [Wmax]}} + \frac{\text{Moment [mn]}}{\text{Allowable moment [Mn]}}$$

Load mass [W] are as follows in compliance to the mounting way.

Horizontal mounting: W

Inclined mounting: $W \cos \theta$ (θ : Angle of inclination, refer to the figure below.)

Vertical mounting: 0 (None)

The moment load rate must be calculated in accordance with the above formula for all types, M1 to M3.

As for W_{max} and M_n , refer to the maximum load mass and allowable moment table in the next section.

The moment for the inclined mounting must be calculated taking the moment caused by the load into consideration.

Note) Make sure that the distance between the guide shaft center to the center of gravity of the load does not exceed the distance GP between the guide shafts given in the table below. If the distance must be exceeded due to unavoidable circumstances, decrease the load rate that is applied to the guide as indicated below in order to determine the distance.

$$\sum \alpha \cdot n \leq \frac{1}{(L/GP)^2} \quad (\text{Provided that } L > GP)$$

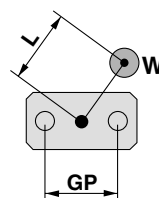

Bore size	12	16	20	25	32	40
Distance between guide rods GP (mm)	50	65	80	90	110	130

Horizontal mounting: $f = \mu \times W$

Inclined mounting: $f = \mu \times W \cos \theta + W \sin \theta$
(Refer to the figure on the right.)

Vertical mounting: $f = W$

$\mu = 0.3$ (Slide bearing)

$\mu = 0.1$ (Ball bushing bearing)

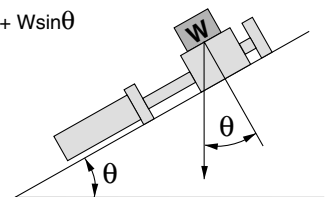

Determine the movable mass W_A which can be operated only by adjusting bolts.

Series CXT

Non-rotating Accuracy of Slide Block

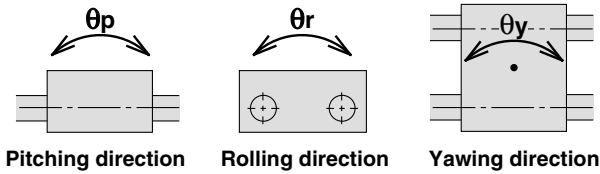

Bore size (mm)	CXTM (Slide bearing)		CXTL (Ball bushing bearing)	
	$\theta_p (= \theta_y)$	θ_r	$\theta_p (= \theta_y)$	θ_r
12	$\pm 0.09^\circ$	$\pm 0.12^\circ$	$\pm 0.05^\circ$	$\pm 0.05^\circ$
16	$\pm 0.08^\circ$	$\pm 0.10^\circ$	$\pm 0.05^\circ$	$\pm 0.04^\circ$
20	$\pm 0.07^\circ$	$\pm 0.08^\circ$	$\pm 0.04^\circ$	$\pm 0.03^\circ$
25	$\pm 0.07^\circ$	$\pm 0.07^\circ$	$\pm 0.04^\circ$	$\pm 0.03^\circ$
32	$\pm 0.08^\circ$	$\pm 0.07^\circ$	$\pm 0.04^\circ$	$\pm 0.03^\circ$
40	$\pm 0.06^\circ$	$\pm 0.06^\circ$	$\pm 0.03^\circ$	$\pm 0.03^\circ$

Maximum Load Mass and Allowable Moment

Bore size (mm)	Bearing	Maximum load mass W_{max} (kg)	Allowable moment (N · m)	
			M1 (= M3)	M2
12	Slide bearing	3	1.25	1.68
	Ball bushing bearing		0.53	0.70
16	Slide bearing	7	3.34	4.25
	Ball bushing bearing		1.53	2.11
20	Slide bearing	12	11.4	17.1
	Ball bushing bearing		5.60	7.28
25	Slide bearing	20	11.4	19.3
	Ball bushing bearing		5.60	8.19
32	Slide bearing	30	19.8	23.3
	Ball bushing bearing		10.1	14.8
40	Slide bearing	50	37.3	46.2
	Ball bushing bearing		21.3	27.5

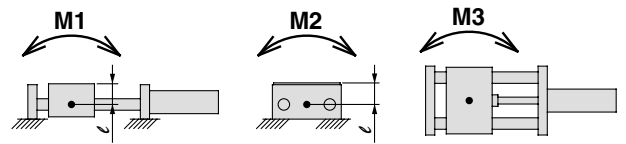

Note) For the purpose of calculating the moment, the length of the arm is the distance that is measured from the guide shaft center ("●" mark). Dimension ℓ from the guide shaft center to the top surface of the table is indicated below.

Bore size	12	16	20	25	32	40
ℓ dimension (mm)	19.5	24	28	31	39.5	47.5

Allowable Load Only by Adjusting Bolt

If only the adjusting bolt is used for stopping the load, make sure that the load mass and the speed will be below the curve in the graph on the right, taking into consideration the durability of the rubber bumper that is attached to the end of the adjusting bolt and the vibration and noise that are created when stopping (provided that the maximum load mass is not exceeded).

In conditions in which the load mass and the speed will be above the curve, use a shock absorber (provided that the maximum load mass is not exceeded).

⚠ Caution

In the case of the ball bushing type, the service life could be drastically shortened if shocks or excessive moments are applied. Therefore, even if the conditions given above are not exceeded, the use of a shock absorber is recommended.

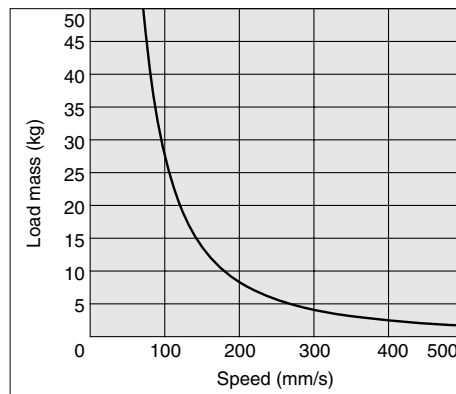

Static Movable Mass when Stopped

When Series CXT cylinder is used for moving the workpiece receptacle, such as in a stamping or press-fitting process, a vertical load will be applied to the top surface of the stopped slide block (refer to the figure on the right). In this case, the allowable mass is greater than the maximum load mass, as given in the table on the right.

⚠ Caution

1. Make sure that the slide block is stopped at the stroke end.
2. Match the center of the mass to be applied with the center of the slide block. The direction of the mass must be vertically downward in relation to the surface on which the workpiece is mounted, as shown in the figure on the right.
3. Do not apply a load that involves shocks such as those caused by pounding (particularly with the ball bushing style).
4. If this mass is applied, the deflection of the guide shaft will also have a large value.

Bore size (mm)	Allowable Static Mass (kg)	
	CXTM (Slide bearing)	CXTL (Ball bushing bearing)
12	350	60
16	500	70
20	900	125
25	900	125
32	1100	140
40	1900	170

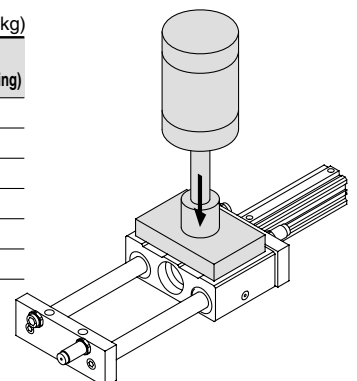

CX2

CXW

CXT

CXSJ

CXS

D-□

-X□

Individual
-X□

Platform Cylinder

Series CXT

ø12, ø16, ø20, ø25, ø32, ø40

How to Order

Port thread type

Nil	M thread	ø12 to ø25
	Rc	
TN	NPT	ø32, ø40
TF	G	

CXT M 20 100 B M9BW

Platform cylinder

Bearing type

M	Slide bearing
L	Ball bushing bearing

Bore size/Stroke (mm)

Bore size (mm)	Stroke (mm)										
	15	25	50	75	100	125	150	175	200	250	300
12	●	●	○	○							
16	●	●	○	○							
20	●	●	○	○							
25	●	●	○	○							
32	●	●	○	○							
40	●	●	○	○							

●Standard stroke ○Long stroke

* For minimum strokes for auto switch equipped style, refer to page 530.

Auto switch

Nil	Without auto switch (Built-in magnet)
-----	---------------------------------------

* For the applicable auto switch model, refer to the table below.

Number of auto switches

Nil	2 pcs.
S	1 pc.
n	"n" pcs.

Option

Nil	Adjusting bolt with bumper only (Standard)
B	With 2 shock absorbers (Set on the driving cylinder side only when packed.)
BS	With 1 shock absorber (Set on the driving cylinder side when packed.)

Shock Absorbers

Type	Bore size (mm)			
	12, 16	20	25	32, 40
Standard (shock absorber Series RB)	RB0806	RB1007	RB1411	RB2015
Shock absorber soft type Series RJ type (-XB22)	RJ0806H	RJ1007H	RJ1412H	—

* The shock absorber service life is different from that of the CXT cylinder. Refer to "Specific Product Precautions" for each shock absorber for the replacement period.
* The shock absorber soft type Series RJ type (-XB22) is a made to order specification. For details, refer to page 1871-1.

Applicable Auto Switch/Refer to pages 1719 to 1827 for further information on auto switches.

Type	Special function	Electrical entry	Wiring (Output)	Load voltage		Auto switch part no.		Lead wire length (m)					Pre-wired connector	Applicable load								
				DC	AC	Perpendicular		In-line		0.5 (Nil)	1 (M)	3 (L)			5 (Z)	None (N)						
						ø12 to ø25	ø32, ø40	ø12 to ø25	ø32, ø40													
Solid state switch	—	Grommet	3-wire (NPN)	5V, 12V		M9NV	M9N	●	●	●	○	—	○	IC circuit								
			3-wire (PNP)					M9PV	M9P	●	●	●	○		—	○						
		Connector	2-wire	12V		M9BV	M9B	●	●	●	○	—	○		—							
			—	J79C	—	—	—	●	—	●	●	●	—		—							
	Diagnostic indication (2-color indication)	Grommet	3-wire (NPN)	5V, 12V	24V	—	M9NVV	M9NW	●	●	●	○	—	○	IC circuit							
			3-wire (PNP)						M9PVV	M9PW	●	●	●	○		—	○					
		Connector	2-wire	12V		M9BWW	M9BW	●	●	●	○	—	○	—								
			3-wire (NPN)	5V, 12V		M9NAV	M9NA	○	○	●	○	—	○	IC circuit								
	Water resistant (2-color indication)	Grommet	3-wire (PNP)	12V		M9PAV	M9PA	○	○	●	○	—	○	IC circuit								
			2-wire	12V		M9BAV	M9BA	○	○	●	○	—	○	—								
With diagnostic output (2-color indication)	Grommet	4-wire	5V, 12V		—	—	F79F	●	—	●	○	—	○	IC circuit								
		—	—	—	—	—	—	—	—	—	—	—	—	—								
Reed switch	—	Grommet	3-wire (NPN equivalent)	—	5V	—	A96V	A96	●	—	●	—	—	—	IC circuit							
									—	200V	—	A72	—	A72H	●	—	●	—	—	—		
									12V	100V	—	A93V	—	A93	●	—	●	—	—	—		
		Connector	2-wire	24V	—	5V, 12V	100 V or less	—	A90V	A90	●	—	●	—	—	—	IC circuit					
											12V	—	—	A73C	—	—	●	—	●	●	—	—
											5V, 12V	24 V or less	—	A80C	—	—	●	—	●	●	●	—
Diagnostic indication (2-color indication)	Grommet	Yes	—	—	—	—	A79W	—	●	—	●	—	—	—	—							
									No	—	—	—	—	—	—	—	—	—	—	—		

* Lead wire length symbols: 0.5 m Nil (Example) M9NV
1 m M (Example) M9NWM
3 m L (Example) M9NWL
5 m Z (Example) M9NWZ
None N (Example) J79CN

* Solid state auto switches marked with "○" are produced upon receipt of order.

* Since there are other applicable auto switches than listed, refer to page 532 for details.
* For details about auto switches with pre-wired connector, refer to pages 1784 and 1785.
* When D-A9□/M9□ types with ø32 to ø40 are mounted on a side other than the port side, order auto switch mounting brackets separately. Refer to page 532 for details.

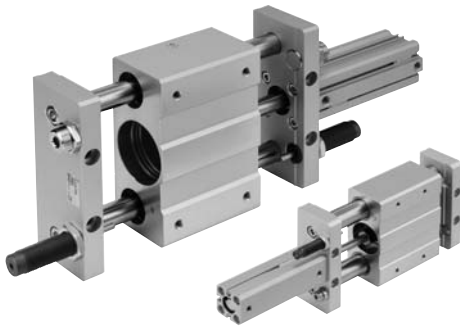

Specifications

Bore size (mm)	12	16	20	25	32	40
Fluid	Air					
Action	Double acting					
Proof pressure	1.5 MPa					
Maximum operating pressure	0.7 MPa ^{Note)}					
Minimum operating pressure	0.15 MPa					
Ambient and fluid temperature	-10 to 60°C (No freezing)					
Piston speed	50 to 500 mm/s					
Cushion	Bumper (Both ends/Standard), Shock absorber (Option)					
Lubrication	Not required (Non-lube)					
Stroke adjusting range	-10 mm (Extension end, Retraction end: -5 mm each)					



Note) Maximum operating pressure for this product with the bumper feature.
The maximum operating pressure for the cylinder alone is 1 MPa.

For detailed specifications about shock absorber, refer to page 1673

Shock Absorber Specifications

Model	CXT□ 12 16	CXT□20	CXT□25	CXT□ 32 40	
Shock absorber model	RB0806	RB1007	RB1411	RB2015	
Max. energy absorption (J)	2.94	5.88	14.7	58.8	
Stroke absorption (mm)	6	7	11	15	
Collision speed	0.05 to 5 m/s				
Max. operating frequency* (cycle/min)	80	70	45	25	
Ambient temperature	-10 to 80°C				
Spring force (N)	Extended	1.96	4.22	6.86	8.34
	Retracted	4.22	6.86	15.30	20.50
Mass (g)	15	25	65	150	



* It denotes the values at the maximum energy absorption per one cycle. Therefore, the operating frequency can be increased according to the energy absorption.

The shock absorber service life is different from that of the CXT cylinder depending on the operating conditions. Refer to the Specific Product Precautions for the replacement period.



Made to Order Specifications
(For details, refer to pages 1865 and 1993.)

Symbol	Specifications
XB13	Low speed cylinder (5 to 50 mm/s)
XB22	Shock absorber soft type Series RJ type
X138	Adjustable stroke type
X777	Fluororubber seals (Actuating cylinder unit only)

Theoretical Output

Bore size (mm)	Operating direction	Piston area (mm ²)	Operating pressure (MPa)		
			0.3	0.5	0.7
12	IN	84.8	25	42	59
	OUT	113	34	57	79
16	IN	151	45	75	106
	OUT	201	60	101	141
20	IN	236	71	118	165
	OUT	314	94	157	220
25	IN	378	113	189	264
	OUT	491	147	245	344
32	IN	603	181	302	422
	OUT	804	241	402	563
40	IN	1056	317	528	739
	OUT	1257	377	628	880

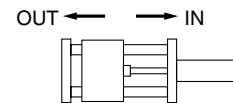

CX2

CXW

CXT

CXSJ

CXS

D-□

-X□

**Individual
-X□**

Series CXT

Mass

CXTM (Slide bearing)

(kg)

Bore size (mm) \ Stroke (mm)	15	25	50	75	100	125	150	175	200	250	300
12	0.85 (0.35)	0.90 (0.35)	1.02 (0.35)	1.13 (0.36)	1.25 (0.37)	—	—	—	—	—	—
16	1.18 (0.50)	1.24 (0.50)	1.39 (0.51)	1.54 (0.52)	1.68 (0.53)	—	—	—	—	—	—
20	—	2.35 (0.85)	2.61 (0.87)	2.89 (0.88)	3.15 (0.90)	3.41 (0.91)	3.66 (0.93)	3.92 (0.94)	4.18 (0.96)	—	—
25	—	2.76 (1.09)	3.03 (1.11)	3.34 (1.14)	3.62 (1.16)	3.89 (1.18)	4.16 (1.21)	4.43 (1.23)	4.70 (1.25)	5.25 (1.30)	5.79 (1.34)
32	—	4.62 (2.06)	4.98 (2.10)	5.34 (2.14)	5.70 (2.17)	6.00 (2.21)	6.35 (2.25)	6.69 (2.29)	7.04 (2.33)	7.73 (2.41)	8.43 (2.49)
40	—	8.30 (3.71)	8.82 (3.75)	9.32 (3.79)	9.83 (3.83)	10.40 (3.87)	10.91 (3.91)	11.43 (3.95)	11.95 (3.99)	12.98 (4.07)	14.02 (4.15)

CXTL (Ball bushing bearing)

(kg)

Bore size (mm) \ Stroke (mm)	15	25	50	75	100	125	150	175	200	250	300
12	0.75 (0.41)	0.78 (0.42)	0.85 (0.42)	0.92 (0.42)	0.98 (0.43)	—	—	—	—	—	—
16	1.05 (0.57)	1.08 (0.57)	1.18 (0.58)	1.27 (0.59)	1.35 (0.60)	—	—	—	—	—	—
20	—	2.00 (1.02)	2.15 (1.04)	2.32 (1.05)	2.46 (1.07)	2.60 (1.08)	2.75 (1.10)	2.89 (1.11)	3.03 (1.13)	—	—
25	—	2.41 (1.25)	2.57 (1.28)	2.77 (1.30)	2.92 (1.33)	3.08 (1.35)	3.24 (1.37)	3.40 (1.39)	3.56 (1.42)	3.78 (1.46)	4.19 (1.50)
32	—	4.23 (2.26)	4.47 (2.30)	4.71 (2.34)	4.95 (2.38)	5.13 (2.42)	5.36 (2.46)	5.59 (2.50)	5.82 (2.54)	6.27 (2.62)	6.73 (2.70)
40	—	7.55 (4.31)	7.86 (4.35)	8.16 (4.39)	8.46 (4.43)	8.82 (4.47)	9.13 (4.51)	9.44 (4.55)	9.75 (4.59)	10.37 (4.67)	10.99 (4.74)

Note 1) (): Denotes the values of the movable parts mass. (Movable parts mass of a cylinder is included, too.)

Note 2) The mass indicated above does not include a shock absorber.

Copper and Fluorine-free (For CRT manufacturing process)

To prevent the influence of copper ions or halogen ions during the CRT manufacturing process, copper and fluorine materials are not used in the component parts.

20-CXT **Bearing type** **Bore size** — **Stroke** **Option** **Auto Switch**

• Copper and fluorine-free

Specifications

Bore size (mm)	12, 16, 20, 25, 32, 40
Fluid	Air
Action	Double acting
Proof pressure	1.5 MPa
Maximum operating pressure	0.7 MPa ^{Note)}
Minimum operating pressure	0.15 MPa
Ambient and fluid temperature	50 to 500 mm/s

* Refer to page 525 for the specifications above and pages 528 and 529 for dimensions.

* Auto switches can be mounted.

Note) The maximum operating pressure for this product taking into account the cushioning ability, etc. The maximum operating pressure for the cylinder alone is 1 MPa.

Construction

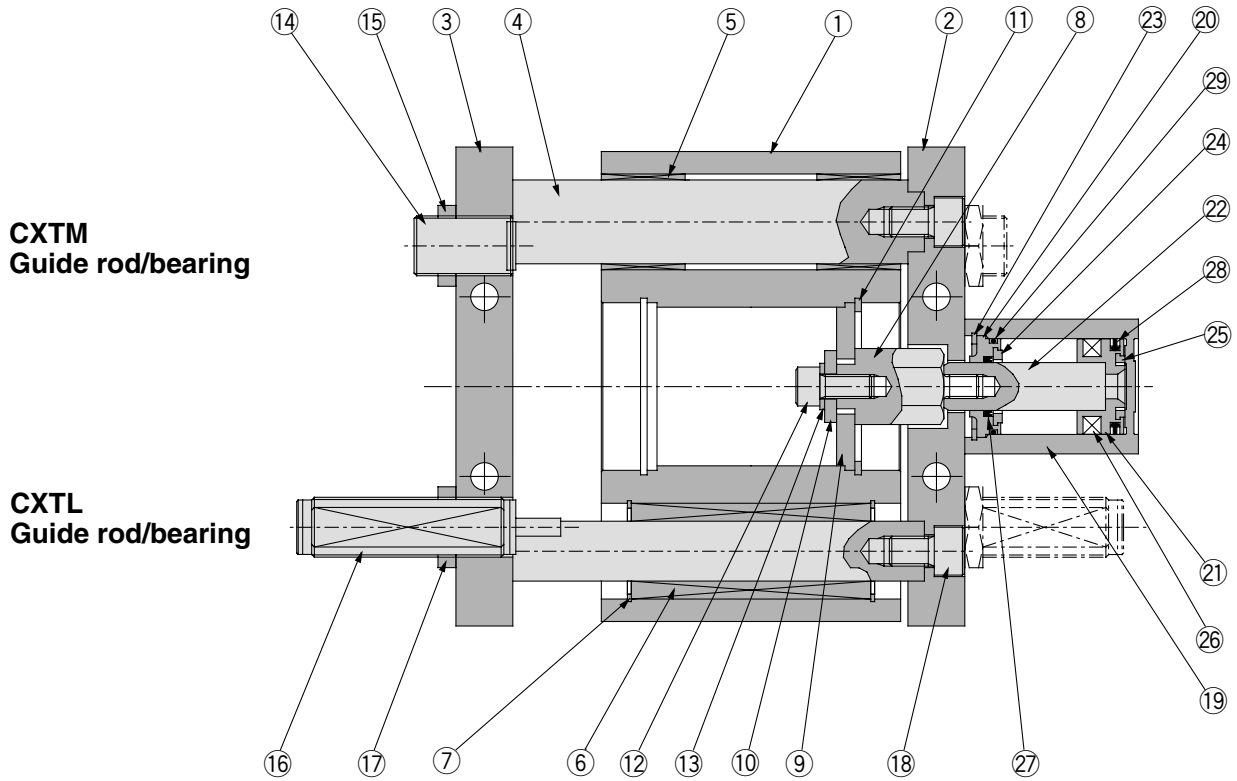

Component Parts

No.	Description	Material	Note
1	Slide block	Aluminum alloy	Clear anodized
2	Plate A	Aluminum alloy	Clear anodized
3	Plate B	Aluminum alloy	Clear anodized
4	Guide rod	CXTM Carbon steel	Hard chrome plated
		CXTL Bearing steel	High frequency quenching, Hard chrome plated
5	Slide bearing	Bearing alloy, Carbon steel	
6	Ball bushing bearing	—	
7	Type C retaining ring	Carbon tool steel	Phosphate coated
8	Adapter	Carbon steel	Electroless nickel plated
9	Connected disk	Carbon steel	Electroless nickel plated
10	Washer	Carbon steel	Colored chromated
11	Type C retaining ring	Carbon tool steel	Phosphate coated
12	Hexagon socket head cap screw	Chromium molybdenum steel	Nickel plated
13	Spring washer	Steel wire	Nickel plated
14	Adjusting bolt (With bumper)	Carbon steel, Elastomer	Nickel plated
15	Nut	Carbon steel	Nickel plated

Component Parts

No.	Description	Material	Note
16	Shock absorber	—	Option
17	Nut	Carbon steel	Shock absorber accessory
18	Hexagon socket head cap screw	Chromium molybdenum steel	Nickel plated
19	Cylinder tube	Aluminum alloy	Hard anodized
20	Collar	Aluminum alloy	Clear anodized
21	Piston	Aluminum alloy	Chromated
		Stainless steel	—
22	Piston rod	—	ø12 to 25
		Carbon steel	Hard chrome plated
23	Type C retaining ring	Carbon tool steel	Phosphate coated
24	Bumper A	Polyurethane	
25	Bumper B	Polyurethane	
26	Magnet	—	
27	Rod seal	NBR	
28	Piston seal	NBR	
29 ^{Note)}	Tube gasket	NBR	

Note) The same type of the part is equipped to the head side for the long stroke type.

Replacement Parts/Seal Kit

Model Cylinder Stroke	Kit no.					
	CXT□12	CXT□16	CXT□20	CXT□25	CXT□32	CXT□40
Standard stroke	CDQSB12	CDQSB16	CDQSB20	CDQSB25	CDQ2A32	CDQ2A40
Long stroke	CQSB12-L-PS	CQSB16-L-PS	CQSB20-L-PS	CQSB25-L-PS	CQ2A32-L-PS	CQ2A40-L-PS

* Seal kit includes 27, 28 and 29. Order the seal kit with the kit number.

* Since the seal kit does not include a grease pack, order it separately.

Grease pack part no.: GR-S-010 (10 g)

CX2

CXW

CXT

CXSJ

CXS

D-□

-X□

Individual
-X□

Series CXT

Dimensions: $\phi 12$ to $\phi 25$

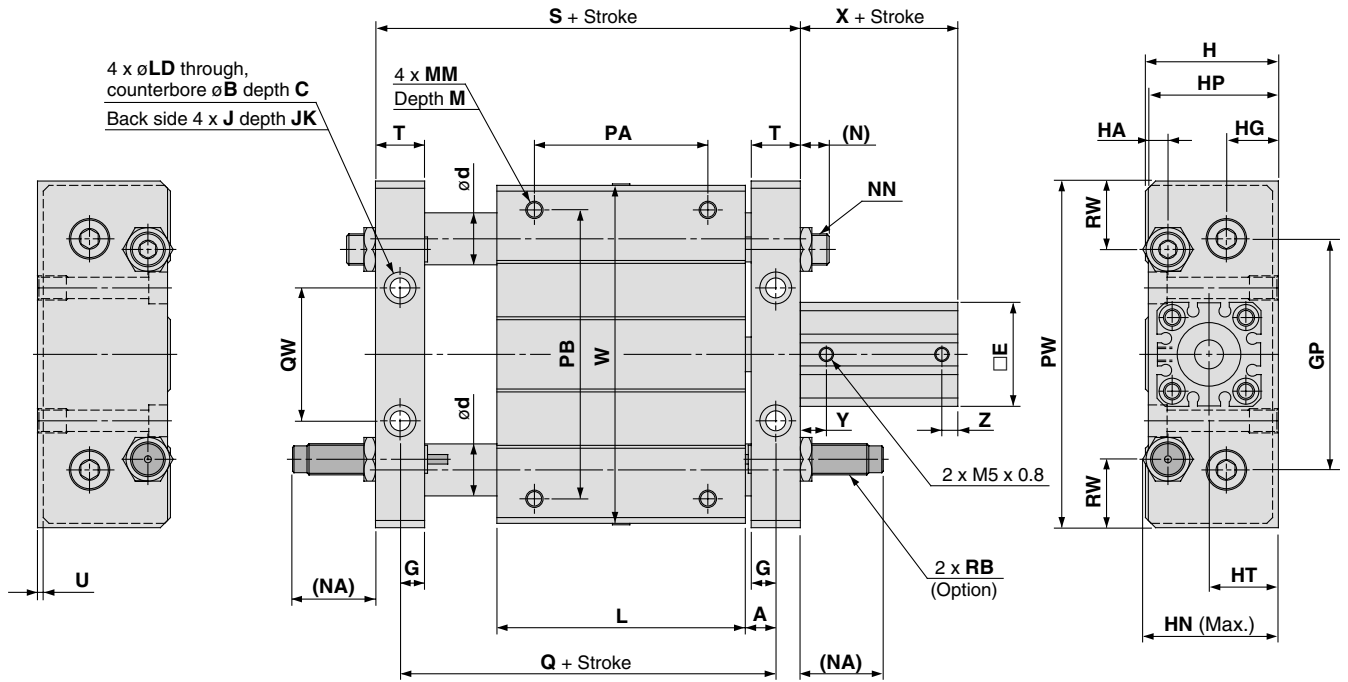

Cylinder form

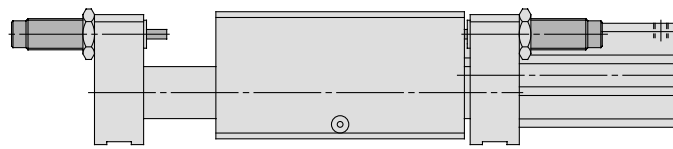

$\phi 12$



$\phi 16$

Bore size (mm)	Standard stroke (mm)	A	B	C	d		E	G	GP	H	HA	HG	HN	HP	HT	J	JK	L	LD
					Slide	Ball bushing													
12	15, 25	8.5	8	4	16	10	25	7.5	50	34	6	14.5	34	33	18	M5 x 0.8	9.5	68	4.3
16	15, 25	7.5	9.5	5	18	12	29	6.5	65	40	6.5	16	39.5	39	21	M6 x 1	9.5	75	5.2
20	25, 50	9.5	11	6.5	25	16	36	8.5	80	46	9	18	44.1	45	24	M8 x 1.25	10	86	6.9
25	25, 50	9.5	11	6.5	25	16	40	8.5	90	54	9	23	55	53	28	M8 x 1.25	10	86	6.9

Bore size (mm)	MM	M	(N)	(NA)	NN	PA*	PB	PW	Q	QW	RB	RW	S	T	U	W	X	Y	Z
12	M4 x 0.7	6	8	27	M8 x 1.0	30	60	80	85	26	RB0806	17.5	96	13	1	77	22	7.5	5
16	M5 x 0.8	8	8	27	M8 x 1.0	45	70	95	90	40	RB0806	15	103	13	2	92	22	7.5	5
20	M6 x 1	10	10	29	M10 x 1.0	60	100	120	105	46	RB1007	26	122	17	2	117	29.5	9	5.5
25	M6 x 1	10	12	50	M14 x 1.5	60	100	130	105	50	RB1411	22	122	17	2	127	32.5	11	5.5

* PA dimension is the center sorted factor of the L dimension.

Long Stroke

Bore size (mm)	Stroke range (mm)	X	Y	Z
12	50, 75, 100	32	7.5	7.5
16	50, 75, 100	32	7.5	7.5
20	75, 100, 125, 150, 175, 200	41	9	9
25	75, 100, 125, 150, 175, 200, 250, 300	44	11	11

Dimensions: $\phi 32, \phi 40$

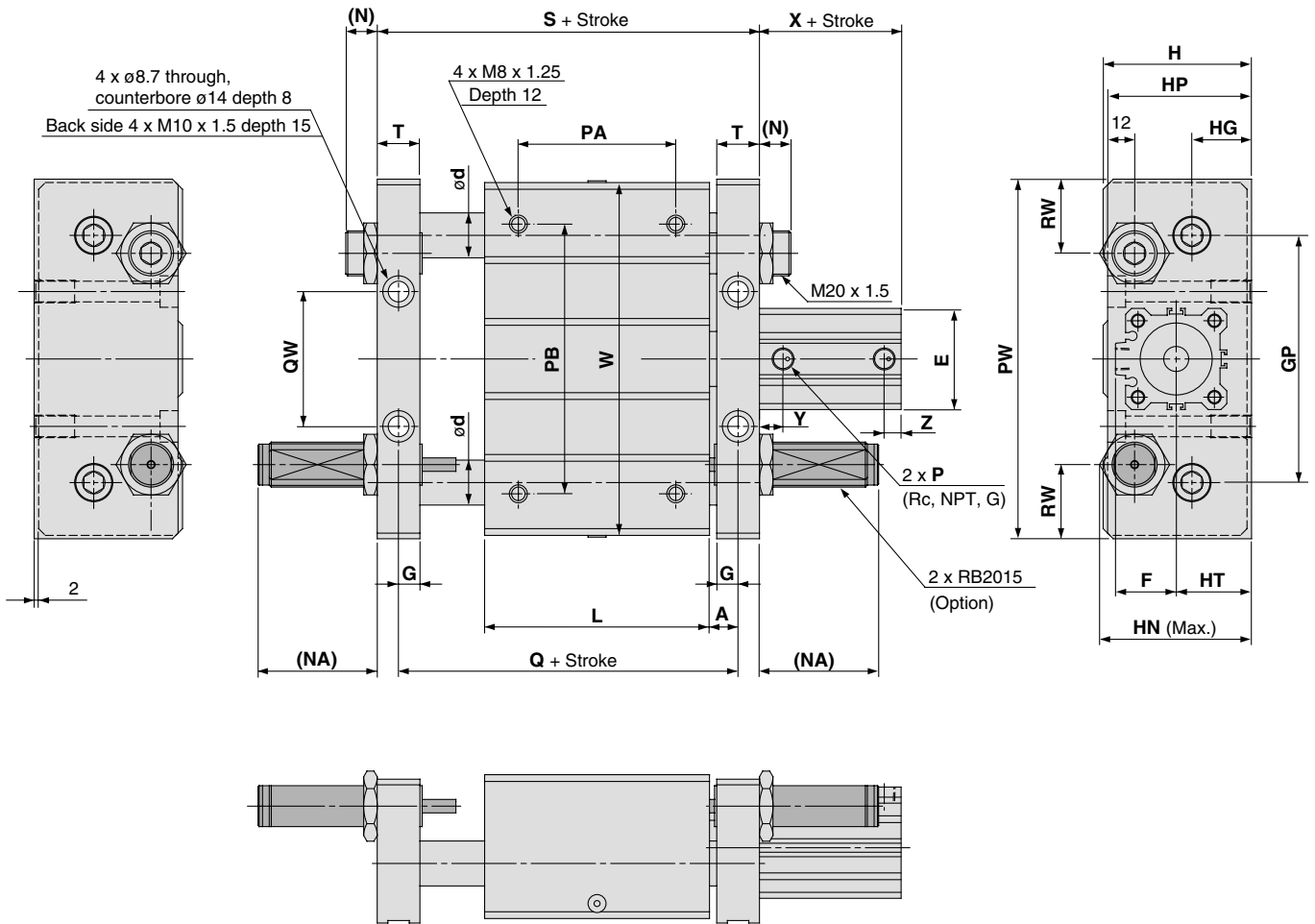

Bore size (mm)	Standard stroke (mm)	A	d		E	F	G	GP	H	HG	HN	HP	HT	L	(N)	(NA)	P ^{Note}	PA*	PB	PW	Q
			Slide	Ball bushing																	
32	25, 50, 75, 100	10.5	28	20	45	27	9.5	110	66	26.5	67.6	64	33.5	100	14	53	1/8	70	120	160	121
40	25, 50, 75, 100	11.5	36	25	52	31	10.5	130	78	30.5	77.6	74	40.5	136	12	51	1/8	90	140	190	159

Bore size (mm)	QW	RW	S	T	W	X	Y	Z
32	60	33	140	19	157	33	10.5	7.5
40	84	35	180	21	187	39.5	11	8

* PA dimension is the center sorted factor of the L dimension.

Note) Rc, NPT and G ports can be selected.

Long Stroke

Bore size (mm)	Stroke range (mm)	X	Y	Z
32	125, 150, 175, 200, 250, 300	45.5	12.5	12.5
40	125, 150, 175, 200, 250, 300	55	14	14

CX2

CXW

CXT

CXSJ

CXS

D-□

-X□

Individual
-X□

Series CXT

Minimum Stroke for Mounting of Auto Switch

Application	Auto switch model No. of auto switches mounted	(mm)					
		D-M9□V	D-A9□V	D-A9□	D-M9□WV D-M9□AVL	D-M9□	D-M9□W D-M9□AL
CXT□12 to CXT□25	1	5	5	10	10	15	20
	2	5	10	10	10	15	20
CXT□32 □40	1	5	5	10	10	10	15
	2	5	10	10	15	10	15

Application	Auto switch model No. of auto switches mounted	(mm)					
		D-F7□V D-J79C	D-A7□ D-A8□ D-A73C D-A80C	D-F7□WV D-F7BAVL	D-A7□H D-A80H D-F7□ D-J79	D-A79W	D-F7□W D-J79W D-F7BAL D-F7NTL D-F79F
CXT□32 □40	1	5	5	10	15	15	20
	2	5	10	15	15	20	20

Proper Auto Switch Mounting Position (Detection at stroke end) and Its Mounting Height

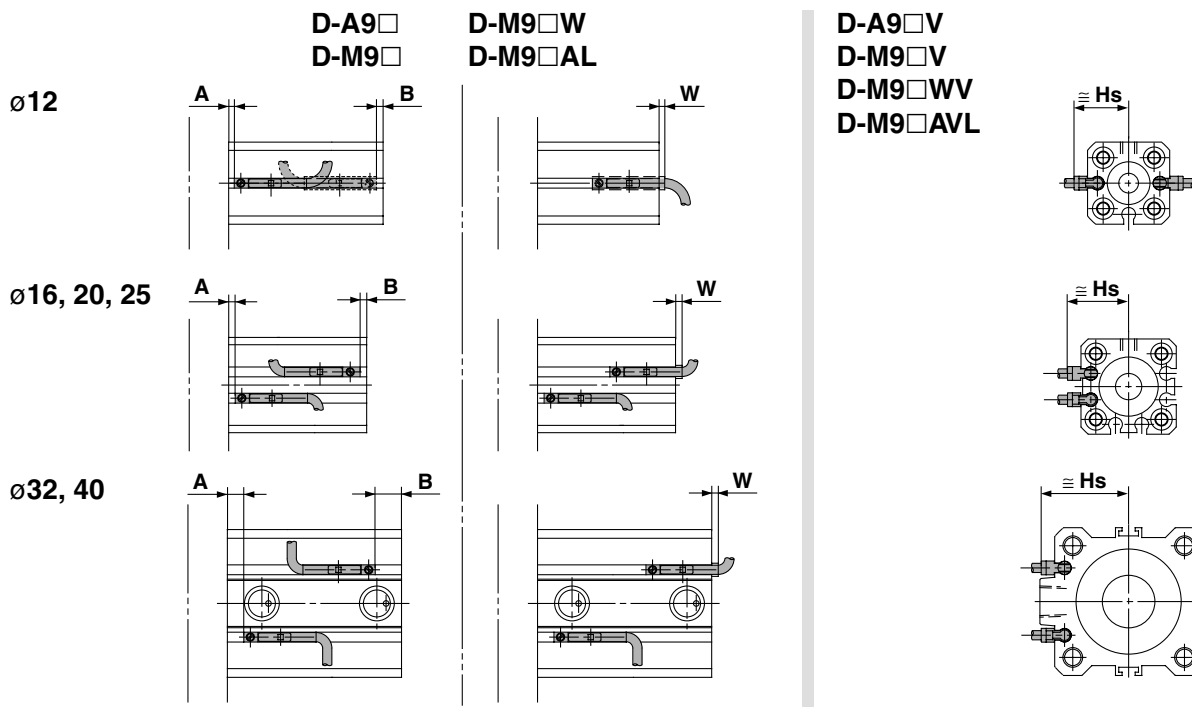

Proper Auto Switch Mounting Position/Standard Stroke

Auto switch model Bore size	D-A9□ D-A9□V			D-M9□/M9□V D-M9□W/M9□WV			D-M9□AL D-M9□AVL		
	A	B	W	A	B	W	A	B	W
12	1.5	0	1.5 (4)	5.5	4.5	5.5	5.5	4.5	7.5
16	2	0	2 (4.5)	6	4	6	6	4	8
20	6	3.5	-1.5 (1)	10	7.5	2.5	10	7.5	4.5
25	7	5.5	-3.5 (-1)	11	9.5	0.5	11	9.5	2.5
32	8	5	-3 (-0.5)	12	9	1	12	9	3
40	12	7.5	-5.5 (-3)	16	11.5	-1.5	16	11.5	0.5

Auto Switch Mounting Height/ Standard Stroke, Long Stroke

Auto switch model Bore size	D-A9□V	D-M9□V D-M9□WV D-M9□AVL
	Hs	Hs
12	17	19
16	19	21
20	22.5	24
25	24.5	26
32	27	29
40	30.5	32.5

Proper Auto Switch Mounting Position/Long Stroke

Auto switch model Bore size	D-A9□ D-A9□V			D-M9□/M9□V D-M9□W/M9□WV			D-M9□AL D-M9□AVL		
	A	B	W	A	B	W	A	B	W
12	5	7	-5 (-2.5)	9	11	-1	9	11	1
16	5.5	6	-4.5 (-2)	9.5	10.5	-0.5	9.5	10.5	1.5
20	9	11.5	-10 (-7.5)	13	16	-6	13	16	-4
25	10	13.5	-12 (-9.5)	14	18	-8	14	18	-6
32	8.5	16.5	-14.5 (-12)	12.5	20.5	-10.5	12.5	20.5	-8.5
40	12	22.5	-20.5 (-18)	16	26.5	-16.5	16	26.5	-14.5

Note 1) (): Denotes the values of D-A93.

Note 2) W is applicable when mounting D-A9□, D-M9□, D-M9□W and D-M9□AL.

Note 3) Adjust the auto switch after confirming the operating conditions in the actual setting.

Auto Switch Proper Mounting Position (Detection at Stroke End) and Its Mounting Height

- | | | |
|--------|---------|---------|
| D-A7□ | D-F7□ | D-F7□V |
| D-A80 | D-J79 | D-J79C |
| D-A73C | D-F7□W | D-F7□WV |
| D-A80C | D-J79W | D-F7BAL |
| D-A79W | D-F7BAL | |
| D-A7□H | D-F79F | |
| D-A80H | D-F7NTL | |

ø32, 40

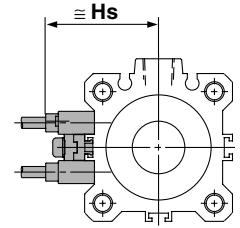
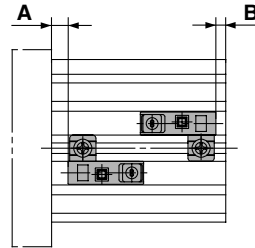

Auto Switch Proper Mounting Position/Standard Stroke

(mm)

Auto switch model \ Bore size	D-A73 D-A80		D-A72/A7□H D-A80H/A73C D-A80C/F7□/J79 D-F7□W/J79W D-F7□V/F7□WV D-F79F/J79C D-F7BAL/F7BAVL		D-A79W		D-F7NTL	
	A	B	A	B	A	B	A	B
32	9	6	9.5	6.5	6.5	3.5	14.5	10.5
40	13	8.5	13.5	9	10.5	6	18.5	13

Auto Switch Proper Mounting Position/Long Stroke

(mm)

Auto switch model \ Bore size	D-A73 D-A80		D-A72/A7□H D-A80H/A73C D-A80C/F7□/J79 D-F7□W/J79W D-F7□V/F7□WV D-F79F/J79C D-F7BAL/F7BAVL		D-A79W		D-F7NTL	
	A	B	A	B	A	B	A	B
32	9.5	17.5	10	18	7	15	15	23
40	13	23.5	13.5	24	10.5	21	18.5	29

Note) Adjust the auto switch after confirming the operating conditions in the actual setting.

Auto Switch Mounting Height/Standard Stroke, Long Stroke

(mm)

Auto switch model \ Bore size	D-A7□ D-A80		D-A7□H D-A80H D-F7□ D-J79 D-F7□W D-J79W D-F79F D-F7BAL D-F7NTL		D-A73C D-A80C		D-A79W		D-F7□V D-F7□WV D-F7BVL		D-J79C	
	Hs	Hs	Hs	Hs	Hs	Hs	Hs	Hs	Hs	Hs	Hs	
32	31.5	32.5	38.5	34	35	38						
40	35	36	42	37.5	38.5	41.5						

Operating Range

(mm)

Auto switch model	Bore size					
	12	16	20	25	32	40
D-A9□/A9□V	6	7.5	10	10	9.5	9.5
D-M9□/M9□V D-M9□W/M9□WV D-M9□AL/M9□AVL	2.5	4	5.5	5.5	6	5.5
D-F7□/F7□V D-J79/J79C D-F7□W/F7□WV D-J79W D-F7BAL/F7BAVL D-F7NTL/F79F	—	—	—	—	6	6
D-A7□/A80	—	—	—	—	12	11
D-A79W	—	—	—	—	13	14

* Since this is a guideline including hysteresis, not meant to be guaranteed. (Assuming approximately ±30% dispersion)
There may be the case it will vary substantially depending on an ambient environment.

* Auto switch mounting brackets BQ2-012 are not used for sizes over ø32 of D-A9□(V)/M9□(V)/M9□W(V)/M9□A(V)L types. The above values indicate the operating range when mounted with the conventional auto switch installation groove.

CX2

CXW

CXT

CXSJ

CXS

D-□

-X□

Individual
-X□

Series CXT

Auto Switch Mounting Bracket: Part No.

Auto switch mounting surface	Bore size (mm)		
	ø12	ø16, ø20, ø25	ø32, ø40
Auto switch mounting surface	Auto switch mounting surface	Auto switch mounting surface	Auto switch mounting surface
Auto switch model	A, B and C sides	Port A, B and C sides	Port side A, B and C sides
D-A9□ D-A9□V D-M9□ D-M9□V D-M9□W D-M9□WV D-M9□AL D-M9□AVL	Auto switch mounting bracket not required.	Auto switch mounting bracket not required.	Auto switch mounting bracket not required. ① BQ-2 ② BQ2-012 2 kinds of auto switch mounting brackets are available as a set.

Note 1) For each cylinder series, when a compact auto switch is mounted on the three sides (A, B and C above) other than the port side of bore sizes ø32 and ø40, the auto switch mounting brackets above are required. Order them separately from cylinders.

Order example
 CXTM32-50-M9BW.....1
 BQ-2.....2 pcs.
 BQ2-012.....2 pcs.

Note 2) When shipping cylinders, auto switch mounting brackets and auto switches are shipped together.

Auto switch model	Bore size (mm)	
	32	40
D-A7□/A80 D-A73C/A80C D-A7□H/A80H D-A79W D-F7□/J79 D-F7□V D-J79C D-F7□W/J79W D-F7□WV D-F7BAL/F7BAVL D-F79F/F7NTL		BQ-2

Note) When shipping cylinders, auto switch mounting brackets and auto switches are shipped together.

[Mounting screw set made of stainless steel]

The following set of mounting screws made of stainless steel (including nuts) is available. Use it in accordance with the operating environment. (Please order the auto switch mounting bracket separately, since it is not included.)

BBA2: For D-A7/A8/F7/J7 types

D-F7BAL and F7BAVL auto switches are set on the cylinder with the stainless steel screws above when shipped. When an auto switch is shipped independently, BBA2 is attached.

Note 4) Refer to page 1817 for the details of BBA2.

Note 5) When D-M9□A(V)L type is mounted on a side other than ø32 and ø40 port sides, order auto switch mounting brackets BQ2-012S and BQ-2, and a stainless steel screw set BBA2.

Auto Switch Mounting Bracket Mass

Auto switch mounting bracket part no.	Mass (g)
BQ-2	1.5
BQ2-012	5

Other Applicable Auto Switches

Refer to pages 1719 to 1827 for the detailed specifications of auto switches.

Auto switch type	Model	Electrical entry (Fetching direction)	Features
Reed	D-A73	Grommet (Perpendicular)	—
	D-A80		Without indicator light
	D-A73H, A76H	Grommet (In-line)	—
	D-A80H		Without indicator light
Solid state	D-F7NV, F7PV, F7BV	Grommet (Perpendicular)	—
	D-F7NWV, F7BWV		Diagnostic indication (2-color indication)
	D-F7BAVL		Water resistant (2-color indication)
	D-F79, F7P, J79	Grommet (In-line)	—
	D-F79W, F7PW, J79W		Diagnostic indication (2-color indication)
	D-F7BAL		Water resistant (2-color indication)
	D-F7NTL		With timer

* For solid state auto switches, auto switches with a pre-wired connector are also available. Refer to pages 1784 and 1785 for details.

* Normally closed (NC = b contact), solid state auto switch (D-F9G/F9H type) are also available. For details, refer to page 1746.

* D-A7/A8/F7/J7 types cannot be mounted on ø12 to ø25.

- If the cylinder is used in an application in which a magnetic material is placed in close contact around the cylinder as shown in the graph on the below (including cases in which even one of the sides is in close contact) the operation of auto switches could become unstable. Therefore, please check with SMC for this type of application.

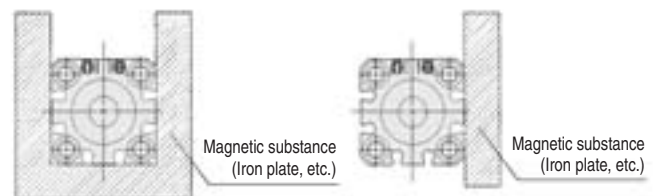



Series CXT Specific Product Precautions

Be sure to read before handling.
Refer to front matters 42 and 43 for Safety Instructions and pages 3 to 11 for Actuator and Auto Switch Precautions.

Operating Precautions

⚠ Caution

1. Make sure not to apply to the slide block a load that exceeds the value that has been calculated in the selection procedures.
2. Operate the cylinder securing it by its plates, not by securing it by its slide block.
3. The clearance between the slide block and the plate at the stroke end is approximately 1 mm to 6 mm. It could be extremely dangerous, as there is the risk of getting your fingers caught.

Install a cover as necessary.

4. At both stroke ends, adjust the damper portion at the end of the adjusting bolt so that it comes in contact with the slide block. (The clearance between the slide block and the plate must be 1 mm or more.)

If it is operated without making any contact, the piston rod of the actuating cylinder or the connecting hardware (adapter) could become damaged by an excessive impact, or the slide block could collide with the plate and create an abnormal noise.

5. The load mass or operating speed will be limited if only the adjusting bolt is used.

Refer to the section on "Allowable load when only the adjusting bolt is used" on page 523

6. Please contact SMC if this product will be used in an environment in which the piston rod and the guide shaft surfaces will be exposed to water (hot water), coolant, cutting chips, or dust.

7. The slide block bearings must be greased periodically. Inject grease (Class 1 or 2 lithium soap grease consistency) through the grease inlet.

Note) On those with a cylinder bore of $\phi 12$, apply grease to the guide shaft.

8. To operate the cylinder, use a non-lubricating air supply. Use turbine oil Class 1 (ISO VG32), if lubricated. (Using machine oil or spindle oil are not allowed.)

Mounting

⚠ Caution

1. While a high level of flatness is desired for the surface on which the cylinder is to be mounted, if sufficient flatness cannot be attained, use shims to adjust the installation of the cylinder so that the slide block can operate throughout its stroke under the minimum operating pressure.

2. Do not scratch or gouge the piston rod of the actuating cylinder, as this could damage the rod seal and lead to air leaks.

The same applies to the guide shaft.

3. Make sure not to apply shocks or excessive moment to the slide block of the ball bushing type.

4. The port direction of the actuating cylinder can be changed in 90° increments by removing the four bolts that secure the cylinder in place.

After changing the direction, verify the operation at the minimum operating pressure.

5. Before the installation, thoroughly flush out the piping to prevent dust or cutting chips from entering the cylinder.

6. The mounting position of the adjusting bolt and the shock absorber cannot be inverted due to the constraints imposed by the locating pin for the shock absorber that is provided on the slide block.

To invert the position, please contact SMC.

Handling on Shock Absorber

⚠ Caution

1. Series RB (SMC made) shock absorbers can absorb a wide range of energy without requiring adjustment. (No adjustment screw is provided.)

2. The screw at the bottom is not for adjustment.

Never turn this screw as it could cause an oil leak (lowered performance).

3. Do not scratch the surface of the shock absorber rod because doing so could affect the shock absorber's durability or lead to poor retraction.

* For detailed specifications about the shock absorber, refer to page 1673.

Service Life and Replacement Period of Shock Absorber

⚠ Caution

1. Allowable operating cycle under the specifications set in this catalog is shown below.

- 1.2 million cycles RB08□□
- 2 million cycles RB10□□ to RB2725

Note) Specified service life (suitable replacement period) is the value at room temperature (20 to 25°C). The period may vary depending on the temperature and other conditions. In some cases the absorber may need to be replaced before the allowable operating cycle above.

CX2

CXW

CXT

CXSJ

CXS

D-□

-X□

Individual
-X□