

PBN Series

Pressure Switches and Sensors

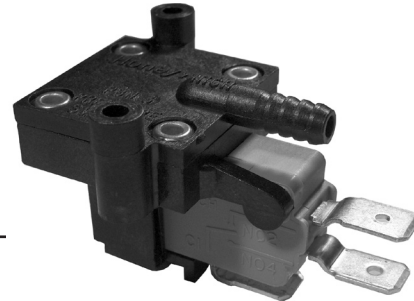

DESCRIPTION

The Honeywell PBN series is a range of versatile, low-cost, ultra-low pressure switches and sensors.

PBN products are compact, lightweight, feature high reliability, and are designed to yield a repeatable response over millions of cycles. They can be mounted in virtually any orientation

and their rugged construction allows use in the most rigorous environments.

Product specifications such as operating characteristics, termination type and contact materials can be customised for certain applications.

FEATURES

- Sensitive to ultra-low pressures
- Gage, vacuum and differential measurement
- Miniature size
- Lightweight
- Fast response
- Rugged housings
- Shock and vibration resistant
- Low and high current versions

POTENTIAL APPLICATIONS

- Arc fault detection
- Filter restriction
- Safety interlock
- HVAC
- Vacuum control
- Liquid level sensing
- Pick and place machinery
- Pump control
- Counters
- Edge detection
- Traffic counters
- Motor control

PBN1

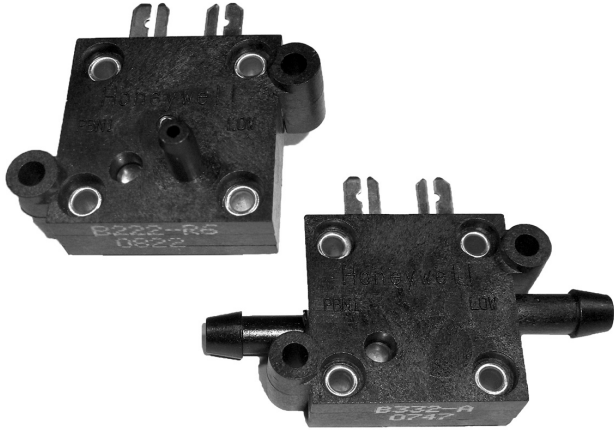

DESCRIPTION

The PBN1 series is available in a wide range of actuation pressures. The required pressure can be supplied factory set or as an adjustable unit. Smooth 4 mm diameter ports perpendicular to the housing and 5 mm barbed radial ports are available. Nominal actuation pressure varies from 1 in-H₂O to 50 in-H₂O on factory set models. Adjustable models have actuation pressures which can be set up to 416 in-H₂O.

FEATURES

- Sensitive to ultra-low pressure
- Gauge, vacuum and differential measurement
- Miniature size
- Lightweight
- Fast response
- Rugged housings
- High shock and vibration resistant versions available
- Adjustable and non-adjustable models

POTENTIAL APPLICATIONS

- Arc fault detection
- Filter restriction
- Safety interlock
- HVAC
- Vacuum control
- Liquid level sensing
- Pick and place machinery
- Pump control
- Counters

MECHANICAL SPECIFICATIONS

Characteristic	Measure
Output	SPST normally open
Sensing medium	Air
Expected mechanical life	Up to 20 million cycles depending on load
Proof pressure	8 psi for units where set point is 3.0 in-H ₂ O or less; 15 psi for units where set point is greater than 3.0 in-H ₂ O
Weight	Less than 10 grams
Operating temperature	4 °C to 66 °C with Polyurethane (standard) diaphragm; -40 °C to 96 °C with Teflon (optional) diaphragm
Action pressure	Tolerance ±20 % for non-adjustable sensors except for PBN1XXXX-A which has a tolerance of +0 %/-100 %

PHYSICAL SPECIFICATIONS

Characteristic	Measure
Mounting	2,6 mm (No 4), thread size screws through mounting lugs or 2 mm (No 2) thread size screws through eyelets
Case material	Polycarbonate standard (other materials available upon request)
Contact material	Gold inlay 18 carat on phosphor bronze
Diaphragm material	Polyurethane (standard) Teflon (optional)
Electrical connections	Terminals: 4,8 x 0,5 mm tab-type (bifurcated) for use with female quick disconnects (ref. AMP 2-520182-2 or equivalent)
Pressure ports	Smooth perpendicular and barbed radial
Pressure settings	Factory set or field adjustable (see chart). Switching hysteresis = 0 %

ELECTRICAL SPECIFICATIONS

Characteristic	Measure
Current rating	40 mA resistive for life up to 20 million cycles
Operating voltage	ac/dc – 30 V or less with resistive load or 120 Vac neon lamp load
Contact resistance	1 Ω or less at 150 % of actuation pressure

Ultra-Low Pressure Sensors

ORDERING INFORMATION

Model Number		Nominal Actuation Pressure			Proof Pressure
4mm smooth perpendicular ports	5mm barbed radial ports	in-H ₂ O	mbar	psi	psi
PBN1B222-A	PBN1B332-A	0.5	1,24	0.018	8
PBN1B222-B	PBN1B332-B	1.0	2,49	0.036	8
PBN1B222-C	PBN1B332-C	1.5	3,73	0.054	8
PBN1B222-D	PBN1B332-D	2.0	4,97	0.072	8
PBN1B222-E	PBN1B332-E	3.0	7,46	0.108	8
PBN1B222-F	PBN1B332-F	4.0	9,95	0.144	15
PBN1B222-G	PBN1B332-G	6.0	14,92	0.217	15
PBN1B222-J	PBN1B332-J	8.0	19,89	0.289	15
PBN1B222-K	PBN1B332-K	10.0	24,86	0.361	15
PBN1B222-L	PBN1B332-L	12.0	29,84	0.433	15
PBN1B222-M	PBN1B332-M	15.0	37,30	0.541	15
PBN1B222-N	PBN1B332-N	20.0	49,73	0.722	15
PBN1B222-P	PBN1B332-P	30.0	74,59	1.083	15
PBN1B222-Q	PBN1B332-Q	40.0	99,46	1.444	15
PBN1B222-S	PBN1B332-S	50.0	124,32	1.804	15
Adjustable models					
PBN1B222-R6	PBN1B332-R6	10.0 to 50.0	24,9 to 124,5	0.36 to 1.80	15
PBN1B222-R7	PBN1B332-R7	51.0 to 416.0	127.0 to 1036.0	1.84 to 15.01	15

Note: Electrical ratings – 40 mA. 30 V ac/dc. 120 Vac neon lamp load

Note: Adjustable models – following adj.. set screw should be sealed using suitable RTV sealant

PBN1

Ultra-Low Pressure Sensors

DIMENSIONS

4 mm smooth perpendicular ports

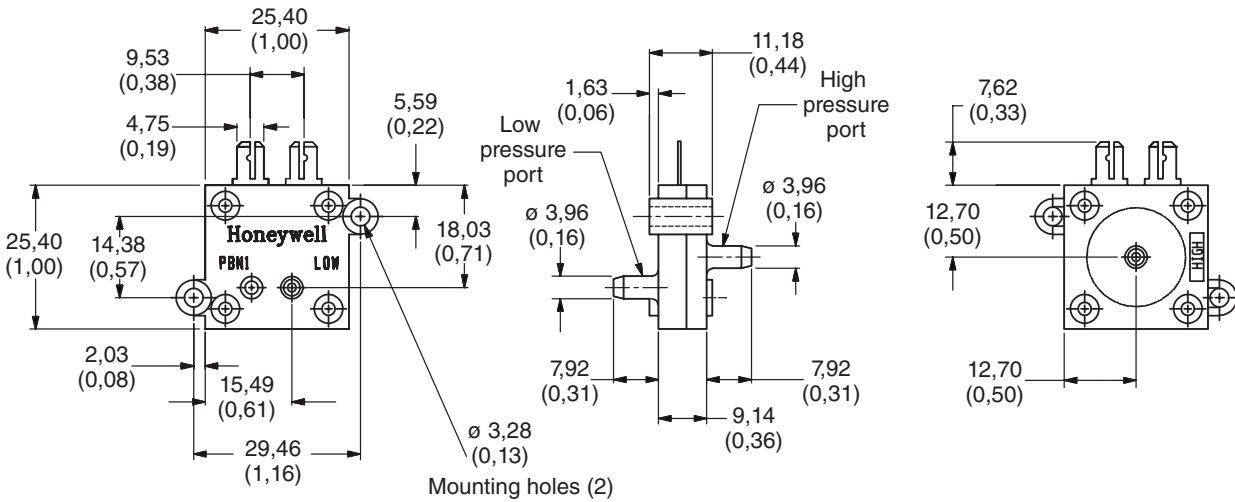

5 mm barbed radial ports

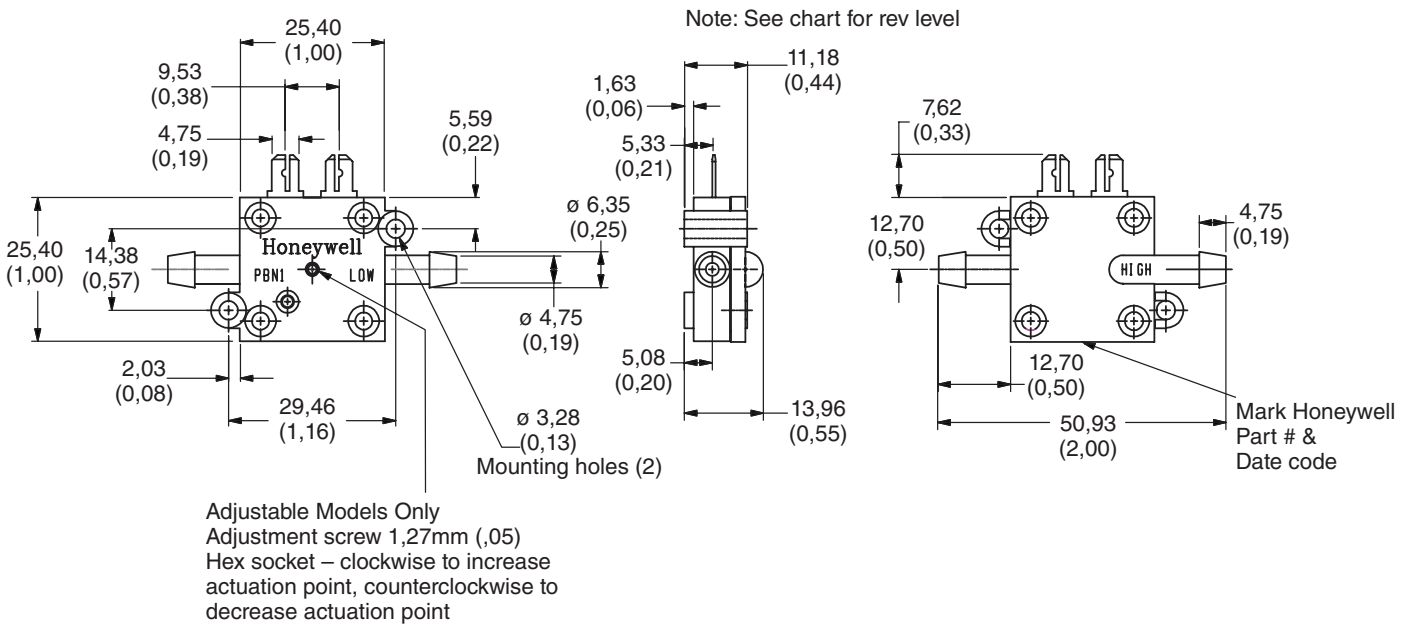

PBN3

High-Current, Low Pressure Sensors



DESCRIPTION

The PBN3 series is a range of miniature, high-current, low-pressure devices which measure gauge pressure and can switch up to 16(4) A. Smooth 4 mm perpendicular ports and 5 mm barbed radial ports are available. Nominal actuation pressure varies from 1 in-H₂O to 6,5 in-H₂O. Adjustable models have actuation pressures which can be set from 10 in-H₂O to 1109 in-H₂O.

PBN3 devices comprise a snap-action SPDT pressure switch which contains an actuator assembly and miniature micro switch. The devices are designed to respond to positive air pressure but may also be activated by non-corrosive liquids at low pressures.

FEATURES

- High current switching capacity
- Sensitive to low gauge pressures
- Miniature size
- Lightweight
- Fast response
- Rugged housings
- Adjustable and non-adjustable models

POTENTIAL APPLICATIONS

- Counting
- Edge detection
- Liquid level sensing
- Traffic counters
- Motor control

MECHANICAL SPECIFICATIONS

Characteristic	Measure
Switch type	SPDT normally open or normally closed
Switching medium	Air or compatible fluids
Expected mechanical life	Up to five million cycles depending on load
Proof pressure	15 psi for units where set point is 75 in-H ₂ O or less; 80 psi for units where set point is greater than 75 in-H ₂ O
Weight	Less than 20 grams
Operating temperature	4 °C to 66 °C with Polyurethane (standard) diaphragm; -40 °C to 96 °C with Teflon (optional) diaphragm

PHYSICAL SPECIFICATIONS

Characteristic	Measure
Mounting	2,6 mm (No 4), thread size screws through mounting lugs or 2 mm (No 2) thread size screws through eyelets
Case material	Polycarbonate and Polyetherimide standard (other materials available upon request) (see chart)
Contact material	Silver (gold available on special order for "dry contact" applications)
Electrical connections	6,3 mm x 0,8 mm quick connect terminals supplied on all listings except PBN3XXXX-B and -D which have 4,8 mm x 0,5 mm connections
Pressure ports	Smooth perpendicular and barbed radial
Pressure settings	Factory set or field adjustable (see chart) Switching hysteresis = 25 % to 50 % of set point

ELECTRICAL SPECIFICATIONS

Characteristic	Measure
Switch type	Single pole double throw
Switch rating	Dependent on actuation pressure (see chart)
Contact voltage	250 Vac

PBN3

ORDERING INFORMATION

Model Number			Actuation Pressure		Tolerance from nominal	AMP rating	Terminal width mm	Proof pressure psi
4 mm smooth perpendicular ports	5 mm barbed radial ports		in-H ₂ O	mbar				
	Same side as terminals	Opposite side from terminals						
PBN3C421-B*	PBN3C441-B*	PBN3C451-B*	1.0	2,49	+100% -50%	3	4,75	15
PBN3C421-D*	PBN3C441-D*	PBN3C451-D*	2.0	4,98	±20 %	3	4,75	15
PBN3C421-H	PBN3D441-H	PBN3D451-H	6.5	16,19	±30 %	5	6,35	15
Adjustable models								
PBN3D421-R1	PBN3D441-R1	PBN3D451-R1	10.0 to 28.0	24,9 to 69,8	N/A	5	6,35	15
PBN3E421-R2	PBN3E441-R2	PBN3E451-R2	35.0 to 75.0	87,0 to 187,0	N/A	16	6,35	15
Listings with polyetherimide as case material								
PBN3E421-R8	PBN3E441-R8	PBN3E451-R8	83.0 to 416.0	207,0 to 1034,0	N/A	16	6,35	80
PBN3E421-R9	PBN3E441-R9	PBN3E451-R9	416.0 to 1109.0	1034,0 to 2758,0	N/A	16	6,35	80

Note: Contact voltage 250 Vac max

*Supplied with terminals 4, 8mm x 0,5 mm instead of standard 6,3 mm x 0,8 mm

DIMENSIONS

4mm smooth perpendicular ports

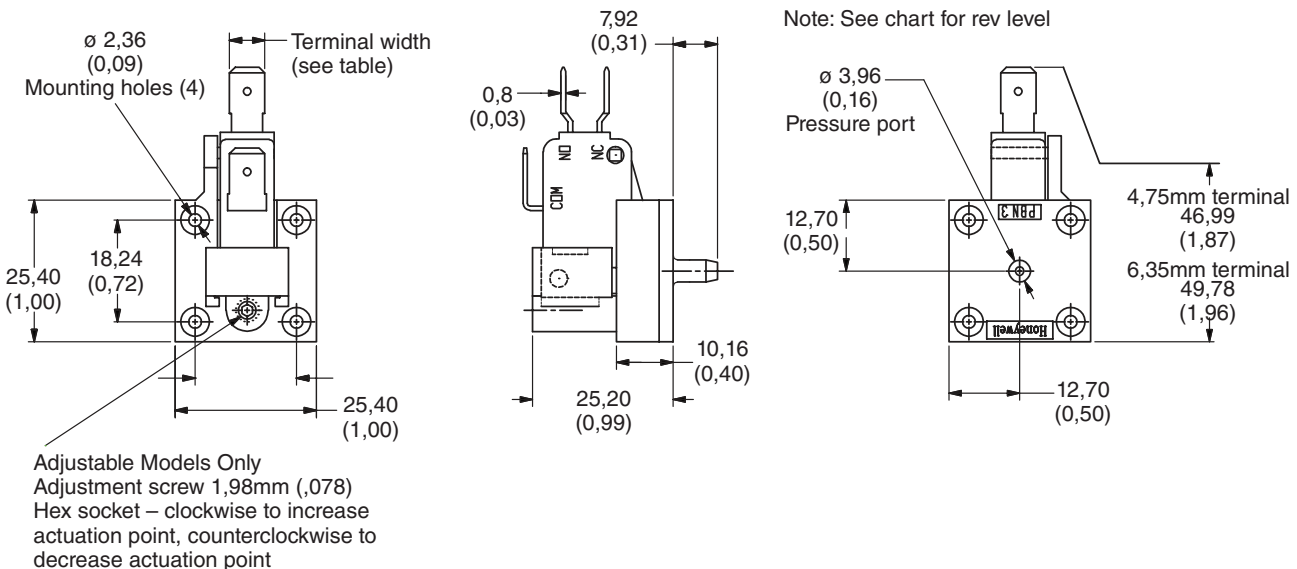

High-Current, Low Pressure Sensors

5 mm barbed radial ports, opposite side from terminals

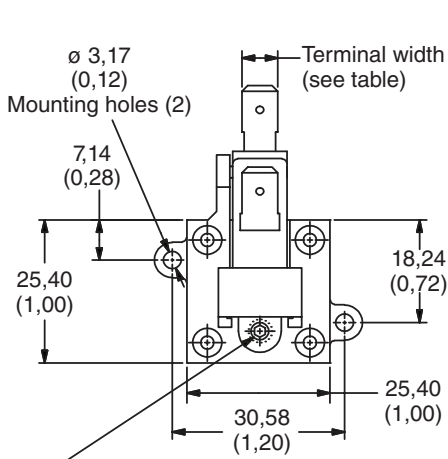

Adjustable Models Only
Adjustment screw 1.98mm (.078)
Hex socket – clockwise to increase
actuation point, counterclockwise to
decrease actuation point

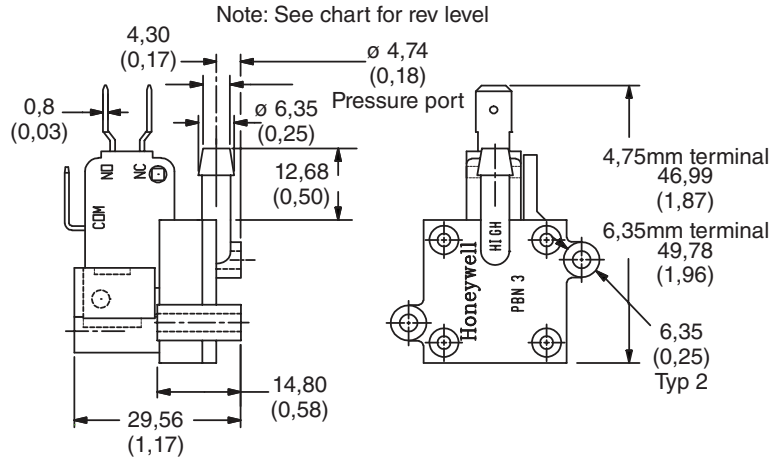

5 mm barbed radial ports, same side from terminals

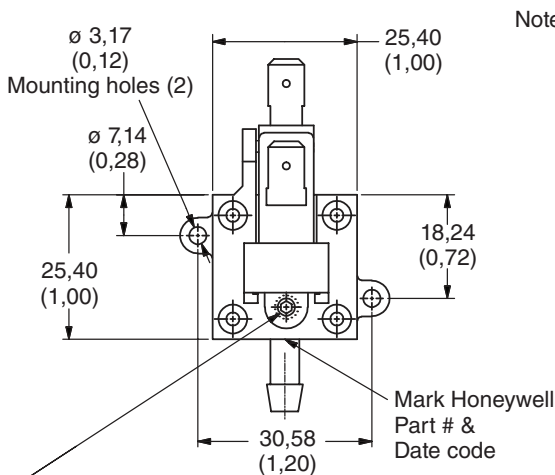

Adjustable Models Only
Adjustment screw 1.98mm (.078)
Hex socket – clockwise to increase
actuation point, counterclockwise to
decrease actuation point

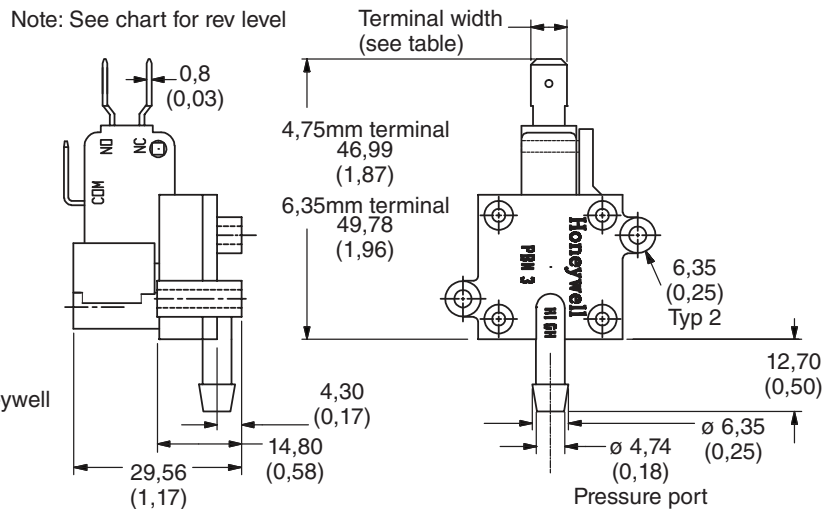

Warranty. Honeywell warrants goods of its manufacture as being free of defective materials and faulty workmanship. Honeywell's standard product warranty applies unless agreed to otherwise by Honeywell in writing; please refer to your order acknowledgement or consult your local sales office for specific warranty details. If warranted goods are returned to Honeywell during the period of coverage, Honeywell will repair or replace, at its option, without charge those items it finds defective. **The foregoing is buyer's sole remedy and is in lieu of all warranties, expressed or implied, including those of merchantability and fitness for a particular purpose. In no event shall Honeywell be liable for consequential, special, or indirect damages.**

While we provide application assistance personally, through our literature and the Honeywell web site, it is up to the customer to determine the suitability of the product in the application.

Specifications may change without notice. The information we supply is believed to be accurate and reliable as of this printing. However, we assume no responsibility for its use.

For more information about Sensing and Control products, visit www.honeywell.com/sensing or call +1-815-235-6847

Email inquiries to info.sc@honeywell.com

WARNING

PERSONAL INJURY

- DO NOT USE these products as safety or emergency stop devices or in any other application where failure of the product could result in personal injury.

Failure to comply with these instructions could result in death or serious injury.

WARNING

MISUSE OF DOCUMENTATION

- The information presented in this catalogue is for reference only. DO NOT USE this document as product installation information.
- Complete installation, operation and maintenance information is provided in the instructions supplied with each product.

Failure to comply with these instructions could result in death or serious injury.

Sensing and Control
Honeywell
1985 Douglas Drive North
Golden Valley, MN 55422 USA
+1-815-235-6847
www.honeywell.com/sensing

ENOM-0358
August 2008
Copyright © 2008 Honeywell International Inc. All rights reserved.

Honeywell

Series 1000

Hydraulic Brake Pressure Switch



DESCRIPTION

The Honeywell Series 1000 pressure switch is a small, low-cost switch actuated by hydraulic fluid or gas. The switch is highly responsive for low-set-point and high burst rating requirements, and may also be used when converting the brake system to hydraulic applications.

With its IP65 sealing and high burst rating, Honeywell's Series 1000 switch often excels in harsh environments such as extreme weather conditions or particle-filled areas. In addition to its high resistance to shock and vibration, this pressure switch is designed to maintain its tolerances across temperature ranges in high system pressure environments.

FEATURES

- Low set point: actuates at 20 psi
- Reduced part count
- High burst rating (for high cost-of-failure applications)
- Banjo bolt fitting
- Sealed to IP65

POTENTIAL APPLICATIONS

- Small vehicle brake light actuation
- Compact agricultural tractors
- Utility vehicles (UTVs)
- Trucks and lift trucks
- Small self-propelled vehicles

BENEFITS

- Low set point is highly responsive
- Reduced field failures at part level
- Enhanced reliability, lowers warranty costs
- Minimized footprint
- Designed for use in high shock and vibration along with most extreme weather conditions

Series 1000

SPECIFICATIONS

Characteristic	Parameter
Type	Direct acting
Circuitry	Normally open
Connector size	M10 x 1.25 banjo fitting
Terminals	6,3 mm [0.25 in] blade
Set point	20 psi \pm 10 psi [1,37 bar \pm 0,69 bar]
Operating pressure, max.	1200 psi [82,74 bar]
Proof pressure	2400 psi [165,47 bar]
Burst pressure	4800 psi [330,95 bar]
Operating temperature	-40 °C to 121 °C [-40 °F to 250 °F]
Operating media	DOT 3 or 4 brake fluid
Electrical rating	12 Vdc with two-1157 bulbs (4.4 A)
Contacts	Silver plated copper
Diaphragm	EPDM
Housing	Rynite 545 glass filled
Base	Trivalent plated steel
Spring	17-7 PH stainless steel
Connector options	M10 x 1.25 double banjo; M10 x 1, 1/8-27 NPT

DIMENSIONS

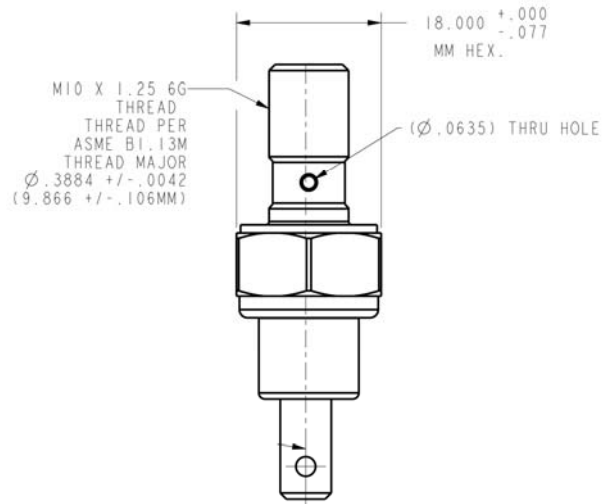
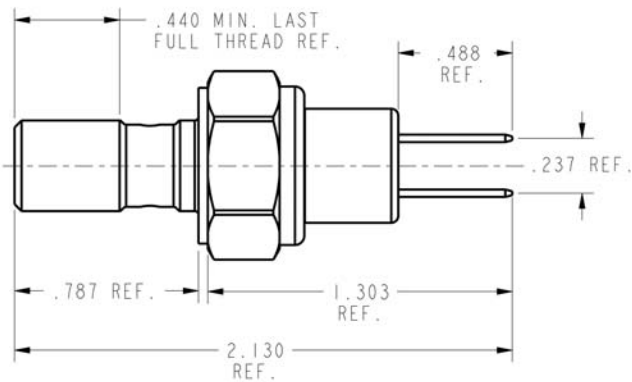

Hydraulic Brake Pressure Switch

ORDER GUIDE

Catalog Listing	Description
83355	Series 1000 hydraulic brake pressure switch, normally open, 20 psi, M10 x 1.25 single banjo fitting, blade terminals
83354	Series 1000 hydraulic brake pressure switch, normally open, 20 psi, M10 x 1.25 double banjo fitting, blade terminals

WARNING

PERSONAL INJURY

DO NOT USE these products as safety or emergency stop devices or in any other application where failure of the product could result in personal injury.

Failure to comply with these instructions could result in death or serious injury.

WARNING

MISUSE OF DOCUMENTATION

- The information presented in this product sheet is for reference only. Do not use this document as a product installation guide.
- Complete installation, operation, and maintenance information is provided in the instructions supplied with each product.

Failure to comply with these instructions could result in death or serious injury.

WARRANTY/REMEDY

Honeywell warrants goods of its manufacture as being free of defective materials and faulty workmanship. Honeywell's standard product warranty applies unless agreed to otherwise by Honeywell in writing; please refer to your order acknowledgement or consult your local sales office for specific warranty details. If warranted goods are returned to Honeywell during the period of coverage, Honeywell will repair or replace, at its option, without charge those items it finds defective. **The foregoing is buyer's sole remedy and is in lieu of all other warranties, expressed or implied, including those of merchantability and fitness for a particular purpose. In no event shall Honeywell be liable for consequential, special, or indirect damages.**

While we provide application assistance personally, through our literature and the Honeywell web site, it is up to the customer to determine the suitability of the product in the application.

Specifications may change without notice. The information we supply is believed to be accurate and reliable as of this printing. However, we assume no responsibility for its use.

SALES AND SERVICE

Honeywell serves its customers through a worldwide network of sales offices, representatives and distributors. For application assistance, current specifications, pricing or name of the nearest Authorized Distributor, contact your local sales office or:

E-mail: info.sc@honeywell.com

Internet: www.honeywell.com/sensing

Phone and Fax:

Asia Pacific +65 6355-2828
+65 6445-3033 Fax
Europe +44 (0) 1698 481481
+44 (0) 1698 481676 Fax
Latin America +1-305-805-8188
+1-305-883-8257 Fax
USA/Canada +1-800-537-6945
+1-815-235-6847
+1-815-235-6545 Fax

Sensing and Control

Honeywell

1985 Douglas Drive North

Golden Valley, Minnesota 55422

www.honeywell.com/sensing

009581-1-EN IL50 GLO Printed in USA

October 2008

Copyright © 2008 Honeywell International Inc. All rights reserved.

Honeywell

Set Points from 0.5 to 150 psi

5000 Series Extended Duty Pressure Switch With Direct Action Blade Contacts

The 5000 Series switch is specifically designed to stand up to extended duty applications. This switch is factory set but capable of field adjustment. It features a Kapton diaphragm for compatibility with a wide variety of fluids, and various terminations including a Metri-Pack connector that forms a tight seal when connected. Among the outstanding design benefits are its durable construction, compact size, and enhanced set point integrity.

Standard Specifications

Type: Direct action blade contact

Contacts: Silver alloy, gold plated

Set Point: Factory set from 0.5 to 150 PSI

Operating Pressure: 150 PSI for 0.5-24 PSI set point range, 250 PSI for 25-150 PSI set point range

Proof Pressure: 500 PSI

Burst Pressure: 750 PSI for 0.5-24 PSI set point range, 1250 PSI for 25-150 PSI set point range.



Switch Boot P/N 79380 for Vacuum and Pressure

Ratings:

Resistive:	15 AMP-	6 VDC
	8 AMP-	12 VDC
	4 AMP-	24 VDC
Inductive:	1 AMP-	120 VAC
	0.5 AMP-	240 VAC

Diaphragm: Polyimide film

Temperature

Range: -40° F to + 250° F

Connector: 1/8 -27 NPT male thread

Terminals: #8-32 screws, 1/4" blade,

280 Series Metri-Pack

Circuitry: SPST-N.O., N.C., 1 circuit adjustable dual circuit, or 2 circuits adjustable dual circuit.

Also available are N.O./N.O. dual circuit and N.C./N.C. dual circuit.

Base: Plated Steel

Cover: Glass reinforced polyester

Options: Brass, plastic or stainless steel base; various base connector thread sizes; wire leads (potted & sealed).

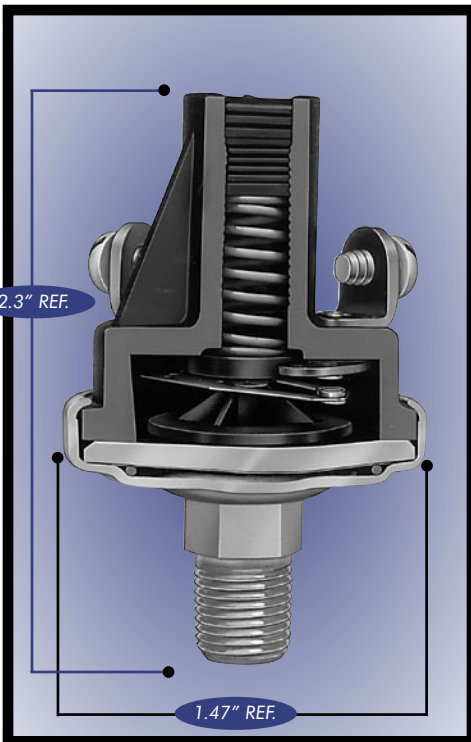

5000 Series Switch with Screw Terminals

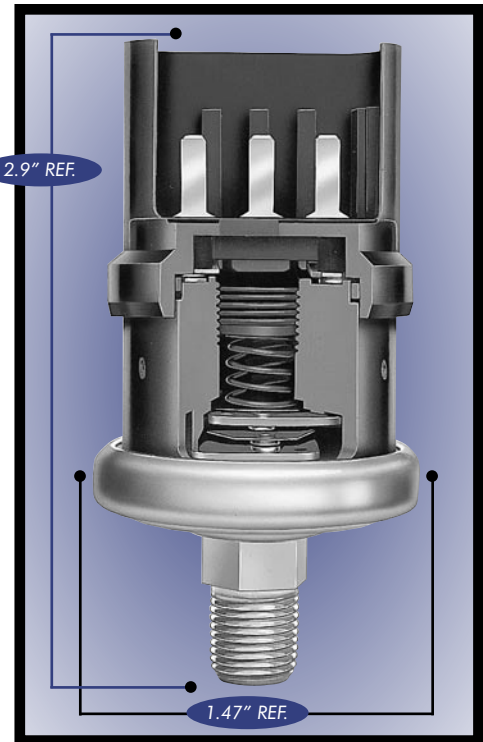

5000 Series Switch with Metri-Pack Terminal

NOTE: OPERATING MEDIA (PRESSURE SWITCH)

The pressure switch is designed to operate with air, motor oils, transmission oils, jet fuels and other similar hydrocarbon media.

5000 Series Pressure Switch With Standard Terminal

			Single Circuit 1 Terminal		Single Circuit 2 Terminals		Dual Circuit One circuit adjustable ¹		Dual Circuit Both circuits adjustable ²		
Contact Setting	Factory Set At	Circuitry	Part Number		Part Number		Part Number		Contact Setting ³	Part Number	
			Screw	Blade	Screw	Blade	Screw	Blade		Screw	Blade
0.5-1 PSI ±0.3	1 PSI	N.O.	78630	78631	78628	78629	78711	78712	3-4 PSI ±0.5	76081	76086
		N.C.	78634	78635	78632	78633					
1.1-3 PSI ±0.5	2 PSI	N.O.	78142	78399	76051	76056	76071	76076	5-8 PSI ±1	76582	76590
		N.C.	78149	78406	76061	76066					
3.1-7 PSI ±1	4 PSI	N.O.	78143	78400	76575	76583	76579	76587	9-24 PSI ±2	76082	76087
		N.C.	78150	78407	76577	76585					
8-13 PSI ±2	10 PSI	N.O.	78144	78401	76576	76584	76580	76588	25-50 PSI ±3	76083	76088
		N.C.	78151	78408	76578	76586					
14-24 PSI ±3	15 PSI	N.O.	78145	78402	76052	76057	76072	76077	51-90 PSI +5/-2	76084	76089
		N.C.	78152	78409	76062	76067					
25-50 PSI ±5	35 PSI	N.O.	78146	78403	76053	76058	76073	76078	91-150 PSI +8/-2	76085	76090
		N.C.	78153	78410	76063	76068					
51-90 PSI ±7	60 PSI	N.O.	78147	78404	76054	76059	76074	76079			
		N.C.	78154	78411	76064	76069					
91-150 PSI ±10	100 PSI	N.O.	78148	78405	76055	76060	76075	76080			
		N.C.	78155	78412	76065	76070					

5000 Series Pressure Switch With Metri-Pack Terminal

			Single Circuit (Mates with Packard P/N 15300027)		Dual Circuit One circuit adjustable ¹ (Mates with Packard P/N 12034147)		Dual Circuit Both circuits adjustable ² (Mates with Packard P/N 12034147)	
Contact Setting	Factory Set At	Circuitry	Part Number	Part Number	Contact Setting ³	Part Number		
1-3 PSI ±0.5	2 PSI	N.O.	77029	77038	3-4 PSI ±0.5	77047		
		N.C.	77020					
4-6 PSI ±1	5 PSI	N.O.	77030	77039	5-10 PSI ±1	77048		
		N.C.	77021					
7-12 PSI ±2	10 PSI	N.O.	77031	77040	11-24 PSI ±2	77049		
		N.C.	77022					
13-24 PSI ±3	20 PSI	N.O.	77032	77041	25-46 PSI ±3	77050		
		N.C.	77023					
25-46 PSI ±5	35 PSI	N.O.	77033	77042	47-76 PSI +5/-2	77051		
		N.C.	77024					
47-76 PSI ±6	60 PSI	N.O.	77034	77043	77-100 PSI +7/-2	77052		
		N.C.	77025					
77-100 PSI ±7	85 PSI	N.O.	77035	77044	101-126 PSI +9/-2	77053		
		N.C.	77026					
101-126 ±9	115 PSI	N.O.	77036	77045	127-150 PSI +10/-2	77054		
		N.C.	77027					
127-150 PSI ±10	135 PSI	N.O.	77037	77046				
		N.C.	77028					

Notes:

- The N.C. circuit is the reference circuit for the dual circuit switch; the normally open circuit is not adjusted. The expected dead band between the N.C. & N.O. circuit is shown in the chart below. For applications requiring the normally open circuit as the reference circuit the N.C. circuit is not adjusted.
- Switch may be adjusted so that:
 - N.C. circuit opens before N.O. circuit closes.
 - N.C. and N.O. circuit have same set point.
 - N.O. circuit closes before the N.C. circuit opens. (There is no dead band and both circuits are on for a brief period of time.)
- The tolerances given in the table are applicable to a switch adjusted so that the N.O. circuit closes before the N.C. circuit opens and applies to the N.C. circuit. The N.O. set point and tolerances are such that a minimum overlap of 1 PSI exists during which both circuits are on.

Note 1: Expected Dead Band (Higher than N.C. circuit)

Contact Setting	Dead Band
0.5-3 PSI	1.5 PSI
4-7 PSI	2.5 PSI
8-13 PSI	3.5 PSI
14-24 PSI	8 PSI
25-50 PSI	15 PSI
51-90 PSI	23 PSI
91-150 PSI	40 PSI