

Integrated Power Center 2 (IPC2™) Centro de alimentación integrado 2 (IPC2™) Centre d'alimentation intégrée 2 (IPC2^{MC})



Instruction Bulletin
Boletín de instrucciones
Directives d'utilisation
Retain for Future Use. / Conservar para
uso futuro. / À conserver pour usage
ultérieur.

IPC2 Section



Integrated Power Center 2 (IPC2™) Class 2735

Instruction Bulletin
Retain for future use.

IPC2 Section



HAZARD CATEGORIES AND SPECIAL SYMBOLS

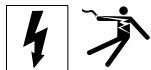

Read these instructions carefully and look at the equipment to become familiar with the device before trying to install, operate, service or maintain it. The following special messages may appear throughout this bulletin or on the equipment to warn of potential hazards or to call attention to information that clarifies or simplifies a procedure.

The addition of either symbol to a “Danger” or “Warning” safety label indicates that an electrical hazard exists which will result in personal injury if the instructions are not followed.

This is the safety alert symbol. It is used to alert you to potential personal injury hazards. Obey all safety messages that follow this symbol to avoid possible injury or death.

⚠ DANGER

DANGER indicates an imminently hazardous situation which, if not avoided, **will result in** death or serious injury.

⚠ WARNING

WARNING indicates a potentially hazardous situation which, if not avoided, **can result in** death or serious injury.

⚠ CAUTION

CAUTION indicates a potentially hazardous situation which, if not avoided, **can result in** minor or moderate injury.

CAUTION

CAUTION, used without the safety alert symbol, indicates a potentially hazardous situation which, if not avoided, **can result in** property damage.

NOTE: Provides additional information to clarify or simplify a procedure.

PLEASE NOTE

Electrical equipment should be installed, operated, serviced, and maintained only by qualified personnel. No responsibility is assumed by Schneider Electric for any consequences arising out of the use of this material.

TABLE OF CONTENTS

Section 1—Introduction	5
Inspection and Packaging	5
Document Replacement	5
Section 2—Safety Precautions	5
Section 3—Receiving, Handling, and Storing	6
Receiving	6
Handling	6
Handling NEMA 1 IPC2™ Enclosures with Lifting Angles.....	7
Handling NEMA 3R Enclosures or NEMA 1 IPC2™ Enclosures with Drip Hoods	9
Storing	10
Section 4—Installation	10
Location	10
Foundation Preparation	10
IPC2™ Preparation	11
General Installation	11
Joining Shipping Sections—Indoor IPC2 and Switchboards	12
Joining Shipping Sections—Outdoor IPC2™ and Switchboards	13
Ground Bus Splice Connections Between IPC2™ and Power-Style® QED Switchboards	14
IPC2 Connection to Indoor Integrated Power Center (IPC) and Modular Panelboard System (MPS)	14
Integrated Power Center (IPC) and IPC2 Enclosure Splice	14
Modular Panelboard System (MPS) and IPC2™ Enclosure Splice	16
Anchoring the IPC2™ for Seismic Qualifications	18
Responsibility for Mitigation of Seismic Damage.....	19
Maintaining Seismic Certification.....	19
Anchoring IPC2 for Seismic Applications	19
Anchoring the IPC2™	20
Grounding and Bonding	20
Service Equipment—Grounded System.....	20
Service Equipment—Ungrounded System.....	21
Not Service Equipment.....	21
High-Impedance Grounded Neutral Systems.....	21
Conduit Area	21
Cable Pulling	22
Cable Terminations	22
Ground-Fault Protection for Equipment	23
Section 5—Pre-Energizing Checkout Procedure	24
Section 6—Energizing the IPC2™	26
Section 7—Maintaining the IPC2™	26
General Inspection and Cleaning	26
Panel Bus Bar Joints, Lug Terminations, and Insulating Materials	27
General Lubrication Information	27
Automatic Transfer Switches	27
Circuit Breakers	28
Ground-Fault Protection for Equipment	28
Other Manufacturers' Devices	29
Section 8—Adverse Circumstances	29
Inspection Following a Short Circuit	29
Clean-up Following a Short Circuit	29
Water-Soaked Equipment	30
Water-Sprayed or Splashed Equipment (Clean Water Only)	30
Inspection and Clean-up of Clean Water Sprayed or Splashed Equipment	30
Section 9—Torque Values for Electrical Connections	31
Section 10—IPC2™ Power Center Insulation Resistance Chart	33
Section 11—Reference Publications	34

LIST OF FIGURES

Figure 1:	Lifting with an Overhead Crane, Lifting Angles, and Cables or Chains	7
Figure 2:	Lifting Warning Labels, IPC2 and Switchboards	8
Figure 3:	IPC2 in Sling Rigging	9
Figure 4:	Forklift Safety Strap	9
Figure 5:	Indoor IPC2™	12
Figure 6:	Joining Adjacent Sections—Outdoor IPC2 and Switchboards	13
Figure 7:	Ground Bus Splice Connection	14
Figure 8:	IPC2 and IPC Shipping Sections	15
Figure 9:	Ground Splice Connection	16
Figure 10:	IPC2 and MPS Shipping Sections	17
Figure 11:	Ground Splice Connection	18
Figure 12:	IPC2 Base Channels	20
Figure 13:	Grounding Electrode Connector	21
Figure 14:	Instantaneous Trip Setting	24

LIST OF TABLES

Table 1:	Blank Fillers and Extensions.....	28
Table 2:	Incoming, Branch, Neutral, and Ground Lugs	31
Table 3:	Multiple Conductor Neutral and/or Ground Terminal	31
Table 4:	Contactors, Terminal Block Conductor, and Torque Data ...	31

SECTION 1—INTRODUCTION

This bulletin contains instructions for the proper installation, operation, and maintenance of Square D® Integrated Power and Control Solutions (IPaCS) Integrated Power Center 2 (IPC2™) equipment manufactured by Schneider Electric. The purchaser's engineering, installation, and operating staff supervisors should familiarize themselves with this bulletin and become acquainted with the appearance and characteristics of each piece of equipment mounted or contained in the IPC2.

These instructions and procedures apply to IPC2 installations by Schneider Electric. When special features or non-standard components are incorporated in the IPC2, detailed instructions for these components are included in the instruction material holder.

Inspection and Packaging

Every IPC2 is carefully inspected and packaged at the assembly plant. Construction of the IPC2 is checked, both structurally and electrically, for compliance with all specifications, codes, and standards. After a complete inspection, the IPC2 is prepared for shipment. The factory order number, the identification number, and the shipping weights are plainly marked on each shipping block.

Document Replacement

Contact your nearest Schneider Electric field office to replace lost or damaged wiring diagrams and instruction sheets. Use the factory order number as a reference.

SECTION 2—SAFETY PRECAUTIONS

<p style="text-align: center;">⚠ DANGER</p> <p>HAZARD OF ELECTRIC SHOCK, EXPLOSION, OR ARC FLASH</p> <ul style="list-style-type: none">• Apply appropriate personal protective equipment (PPE) and follow safe electrical work practices. See NFPA 70E.• This equipment must be installed and serviced only by qualified personnel.• Perform such work only after reading and understanding all of the instructions contained in this bulletin.• Turn off all power supplying this equipment before working on or inside equipment.• Before performing visual inspections, tests, or maintenance on this equipment, disconnect all sources of electric power. Assume all circuits are live until they are completely de-energized, tested, and tagged. Pay particular attention to the design of the power system. Consider all sources of power, including the possibility of backfeeding.• Always use a properly rated voltage sensing device to confirm power is off.• Handle this equipment carefully and install, operate, and maintain it correctly in order for it to function properly. Neglecting fundamental installation and maintenance requirements may lead to personal injury, as well as damage to equipment or other property.• Disconnect the neutral connection at any TVSS or other electronic device prior to performing electrical insulation resistance tests; reconnect to the device after testing.• Carefully inspect your work area and remove any tools and objects left inside the equipment.• Replace all devices, doors, and covers before turning on power to this equipment.• All instructions in this bulletin assume that the customer has taken these measures before performing maintenance or testing. <p>Failure to follow these instructions will result in death or serious injury.</p>

SECTION 3—RECEIVING, HANDLING, AND STORING

Receiving

Upon receipt, check the packing list against the equipment received to ensure the order and shipment are complete. Also upon receipt, immediately inspect the IPC2™ shipping blocks for any damage that may have occurred in transit. If damage is found or suspected, file a claim with the carrier immediately and notify the nearest Schneider Electric representative. Claims for shortages or errors must be made in writing to Schneider Electric within 60 days after delivery. Failure to give such notice will constitute unqualified acceptance and a waiver of all such claims by the purchaser.

Delivery of equipment to a carrier at any of the Schneider Electric plants or other shipping points constitutes delivery to the purchaser regardless of freight payment and title. All risk of loss or damage pass to the purchaser at that time.

For details concerning claims for equipment shortages and other errors, refer to Schneider Electric "Terms and Conditions of Sale."

Handling

CAUTION

HAZARD OF EQUIPMENT DAMAGE

Do not lay the equipment on its back, front, or sides. Contact the local sales office for specific instructions.

Failure to follow this instruction can result in equipment damage.

Ensure that proper equipment, such as an overhead crane, is available at the installation site to handle the IPC2.

The shipping weight of each shipping block is marked on the packing list. Verify the lifting capacity of the equipment being used to handle the IPC2 in accordance with the shipping weight of each shipping block. Keep the IPC2 upright during handling.

Schneider Electric recommends using an overhead crane, lifting angles, and cables or chains to handle the NEMA 1 enclosed IPC2. This method and alternative handling methods are discussed in this section.

Handling NEMA 1 IPC2™ Enclosures with Lifting Angles

NOTE: For NEMA 1 enclosures with drip hoods, see “Handling NEMA 3R Enclosures or NEMA 1 IPC2™ Enclosures with Drip Hoods” on page 9.

Schneider Electric provides lifting angles as standard equipment for NEMA 1 enclosed IPC2™ shipping blocks. Instruction labels on each shipping block include drawings and written instructions outlining the proper use of the lifting angles (Figure 1). Use rigid spreaders or a spanner bar to provide vertical lift on the lifting angles. This will help prevent damage to the frame or finish.

Figure 1: Lifting with an Overhead Crane, Lifting Angles, and Cables or Chains

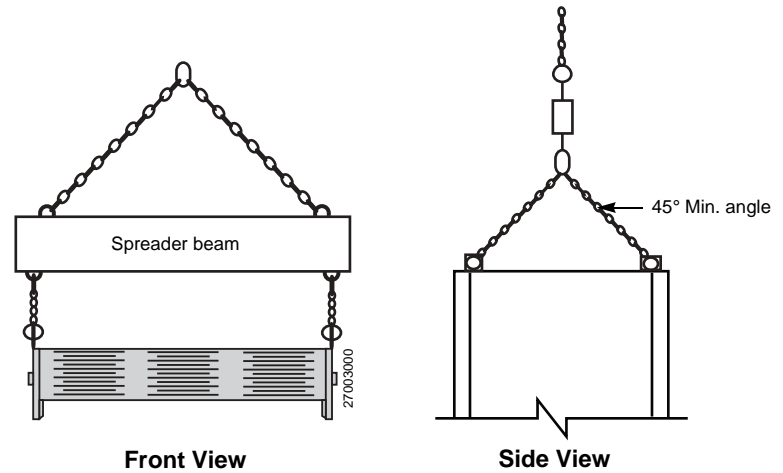

Follow these instructions to handle the NEMA 1 enclosed IPC2:

1. Use load-rated cables or chains with safety hooks or shackles. Do not pass cables or chains through holes in lifting angles.
2. Use a load-rated spreader beam to prevent structure damage. Rig so that the minimum angle between the lifting cables or chains and equipment top is 45 degrees.

The following lifting warning labels (Figure 2) are attached to the IPC2™.

Figure 2: Lifting Warning Labels, IPC2 and Switchboards

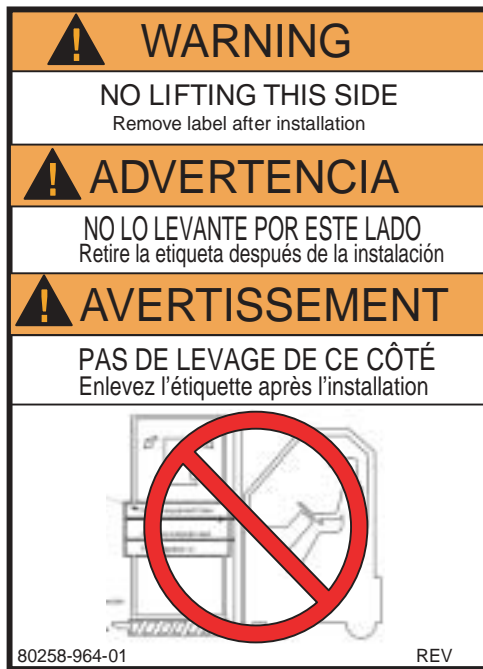

Front Label on IPC2



Rear Label on IPC2

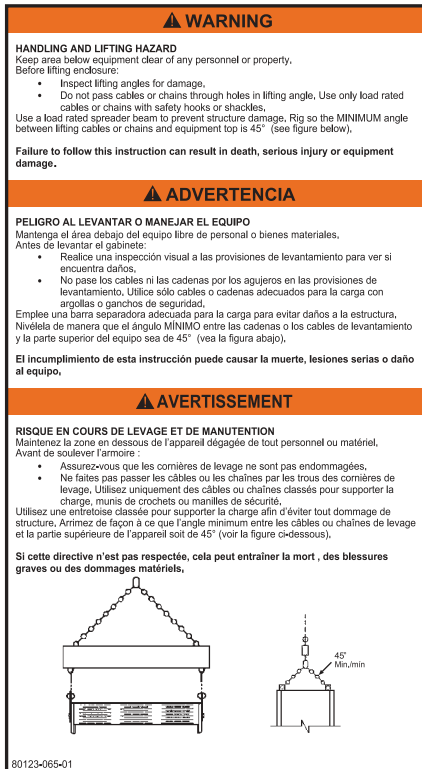

Label Applied Adjacent to Lifting Angles

Handling NEMA 3R Enclosures or NEMA 1 IPC2™ Enclosures with Drip Hoods

Rollers or slings may be used to handle the shipping blocks. When elevating a shipping block without the use of the lifting angles, an overhead crane equipped with either of the following may be used:

- Load rated chain coupled to a sling rigging
- Load rated wire cable with safety hooks and shackles

Wrap the sling completely around the IPC2™ and shipping stringers (see Figure 3).

⚠ WARNING

HAZARD OF EQUIPMENT DAMAGE—TOP HEAVY LOAD

Stabilize the shipping block to reduce the possibility of tipping.

Failure to follow this instruction can result in death or serious injury.

Figure 3: IPC2 in Sling Rigging

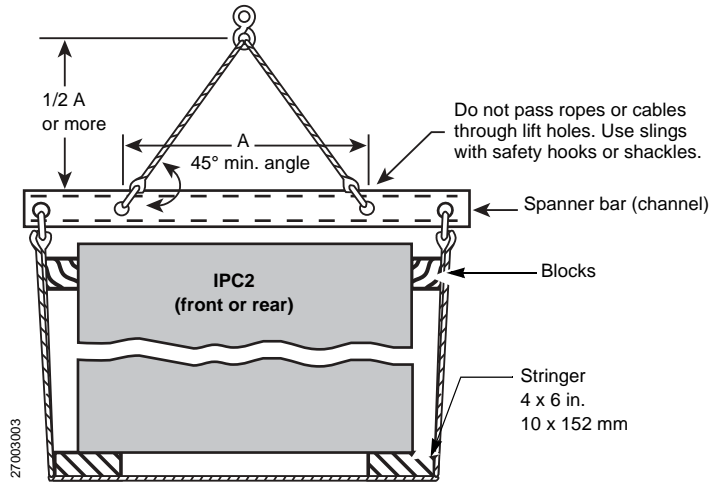

A forklift is an alternative method of handling the IPC2.

NOTE: Always check the fork lengths to ensure that the forks extend under the entire IPC2. Carefully balance the load, and always use a safety strap when handling or moving an IPC2 with a forklift (Figure 4).

Figure 4: Forklift Safety Strap

⚠ WARNING

TOP HEAVY LOAD

May tip resulting in death, severe personal injury, or equipment damage.
Secure to forklift with safety strap.

⚠ ADVERTENCIA

CARGA PESADA EN LA PARTE SUPERIOR

Se puede voltear y causar la muerte, lesiones serias o daño al equipo.
Sujete al montacargas con la correa de seguridad.

⚠ AVERTISSEMENT

CHARGE INSTABLE

Peut se déséquilibrer entraînant la mort, des blessures graves ou des dommages matériels.
Fixer au chariot élévateur avec une sangle de sécurité.

Remove label after installation.
Retire la etiqueta después de la instalación.
Enlever l'étiquette après l'installation.

80258-147-06 REV

Storing

When storing the IPC2™ before installation, cover the top and any openings of the equipment during the construction period to protect the IPC2 from dust and debris.

If a IPC2 is not installed and energized immediately, store it in a clean, dry space with a consistent temperature to prevent condensation. Store the IPC2 indoors, if possible. Preferably, store it in a heated building with adequate air circulation and protect it from dirt, fumes, water, and physical damage. Storing the IPC2 outdoors may cause harmful condensation inside the IPC2.

NOTE: Install portable electric heaters of approximately 250 watts per vertical section in both indoor-type and rainproof-type IPC2 enclosures for adequate protection during storage.

Before energizing the space heaters, remove all loose packing or flammable materials inside the IPC2. Outdoor IPC2 equipment is not weather-resistant until completely and properly installed; treat them the same as indoor IPC2 equipment until after installation.

SECTION 4—INSTALLATION

Correct installation of IPC2 equipment is essential for proper operation of all IPC2 components. Study the associated instruction books and all drawings carefully. In most cases, all drawings are sent to the purchaser before an IPC2 is shipped to enable adequate advance planning.

NOTE: While installing IPC2 equipment, do not use the top of the IPC2 as a support for the weight of the installer.

Location

Find the designated area on the building floor plan where the IPC2 will be installed. The location chosen for installation should provide working clearances complying with Section 110-26 of the National Electrical Code® (NEC®) or Section 2-308 of the Canadian Electrical Code (CEC) Part 1. IPC2 equipment requires field connections, including mains, branches, and ground bus, to be accessible and maintainable from the front.

Foundation Preparation

The floor or foundation must be strong enough to support the weight of the IPC2 without sagging. The surrounding floor area should gently slope toward a drain.

NOTE: For seismic qualifications, read the section “Anchoring the IPC2™ for Seismic Qualifications” on page 18 before pouring the floor or foundation.

IPC2 equipment is assembled on true and level floors at the assembly plant. To ensure correct alignment with adjoining equipment, the mounting pad or final installation site must be smooth and level. If parallel steel floor channels are imbedded for mounting the IPC2, take extra care to ensure the floor channels are level over their entire length to avoid distortion of the IPC2 structure. Each channel should be level with the finished floor.

When pouring the foundation, make provisions for conduits entering the IPC2 from below and carrying the incoming and/or outgoing cables, control wiring, and ground cable. The bottom view in the equipment drawing shows the available conduit area for correct layout.

Conduits should project above the finished floor by about 2.00 in. (51 mm). However, to simplify moving the shipping blocks into place, install the conduits flush with the concrete and, after the blocks are in their final position, add the appropriate extension sleeves. Otherwise, raising the shipping block on timbers or lifting it by a crane to clear the conduit hubs will be necessary.

NOTE: Before pouring the foundation, consider installing additional conduits for future circuits.

IPC2™ Preparation

- Remove dirt and debris from the foundation and surrounding area before moving the IPC2™ into final position.
- After the IPC2 has been moved to its final installation site, take each shipping block off its shipping stringers.
- Remove all packing materials.

General Installation

CAUTION
HAZARD OF EQUIPMENT DAMAGE Level and align adjacent shipping sections with one another. Ensure proper alignment of horizontal main through bus and proper splice bus connections. Failure to follow this instruction can result in equipment damage.

Install the IPC2 into its final position by leveling progressively each section and bolting the frames together, if separated. Position shipping sections as follows:

1. Maneuver each shipping section into the desired position using the procedures under "Handling" on page 6.
2. Carefully lower the equipment over the conduit stubs to comply with the "available conduit area" as shown in the bottom view of the equipment drawings. Otherwise, there may not be sufficient cable bending space.
3. Level the shipping section.
4. After the installation of each section is complete, make the ground bus splice connection to the preceding section before installing the next section.

Joining Shipping Sections—Indoor IPC2 and Switchboards

⚠ DANGER

HAZARD OF ELECTRIC SHOCK, EXPLOSION, OR ARC FLASH

- Apply appropriate personal protective equipment (PPE) and follow safe electrical work practices. See NFPA 70E.
- This equipment must be installed and serviced only by qualified personnel.
- Turn off all power supplying this equipment before working on or inside equipment.
- Always use a properly rated voltage sensing device to confirm power is off.
- Replace all devices, doors, and covers before turning on power to this equipment.

Failure to follow these instructions will result in death and serious injury.

1. Position each adjacent section, carefully leveling and aligning it with the previous section.
2. Open or remove the front and rear doors and panels, providing access to bolt adjacent shipping sections together.
3. Six bolts (3/8-16 x 1 inch) are provided. Place the bolts through the existing holes in the front and rear vertical corner channels to join adjacent sections (Figure 5).
4. Make the ground bus splice connections to the preceding section. See “Ground Bus Splice Connections Between IPC2™ and Power-Style® QED Switchboards” on page 14.
5. Replace and secure all front and rear doors and panels removed in step 2.

Figure 5: Indoor IPC2™

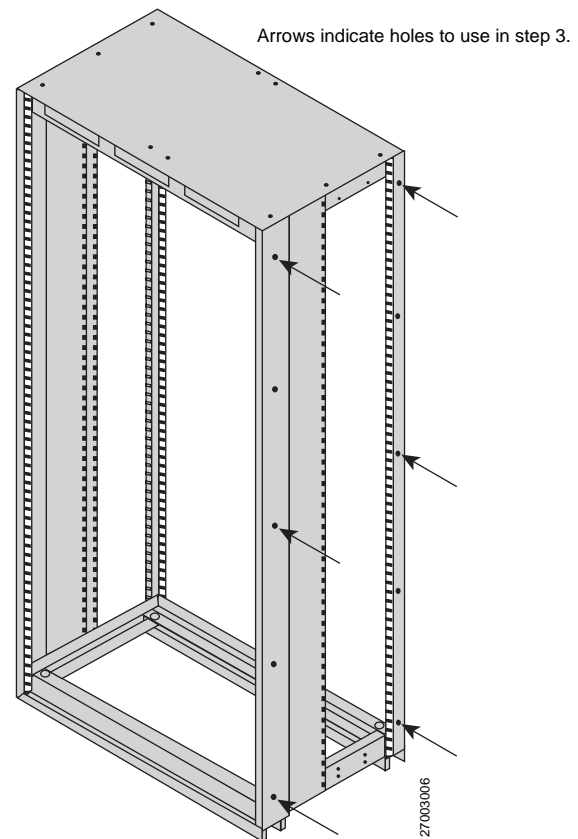

Transformer Combo Section Shown

Joining Shipping Sections—Outdoor IPC2™ and Switchboards

1. Remove the center top cap (Figure 6) from the left-hand section, and retain all hardware for reuse.

Figure 6: Joining Adjacent Sections—Outdoor IPC2 and Switchboards

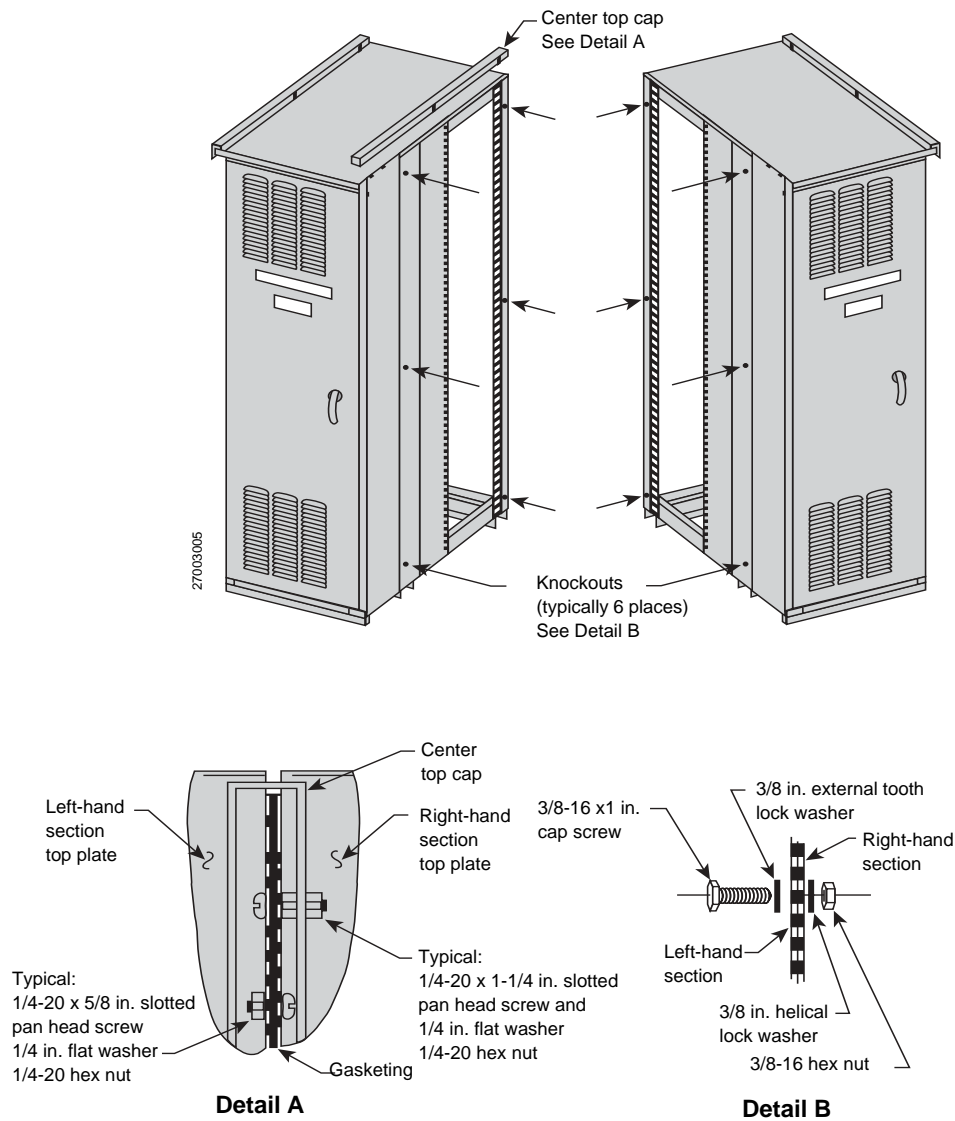

2. When possible, open or remove the front and rear doors and panels, providing access to bolt adjacent shipping sections together.
3. Remove three 0.50-in. (13 mm) diameter knockouts from the front vertical corner channel and three from the rear vertical corner channel (a total of six per frame side) as indicated by the arrows in Figure 6.
4. Position each adjacent section, carefully leveling it and aligning it with the previous section.
5. Six bolts (3/8-16 x 1 inch) are provided. Place them through the holes created in step 3 to join adjacent sections. See Detail B.
6. Make the ground bus splice connections to the preceding section. See “Ground Bus Splice Connections Between IPC2™ and Power-Style® QED Switchboards” on page 14.
7. Replace the center top cap removed in step 1. See Figure 6, Detail A.
8. If applicable, replace and secure all the front and rear doors and panels removed in step 2.

Ground Bus Splice Connections Between IPC2™ and Power-Style® QED Switchboards

⚠ DANGER

HAZARD OF ELECTRIC SHOCK, EXPLOSION, OR ARC FLASH

- Apply appropriate personal protective equipment (PPE) and follow safe electrical work practices. See NFPA 70E.
- This equipment must be installed and serviced only by qualified personnel.
- Turn off all power supplying this equipment before working on or inside equipment.
- Always use a properly rated voltage sensing device to confirm power is off.
- Replace all devices, doors, and covers before turning on power to this equipment.

Failure to follow these instructions will result in death and serious injury.

IPC2 Connection to Indoor Integrated Power Center (IPC) and Modular Panelboard System (MPS)

Integrated Power Center (IPC) and IPC2
Enclosure Splice

Align and secure the ground bus splice connection between shipping sections. Torque connections to 100 lb-in (11 N•m). See Figure 7.

NOTE: Proper installation is essential for equipment ground-fault systems.

Figure 7: Ground Bus Splice Connection

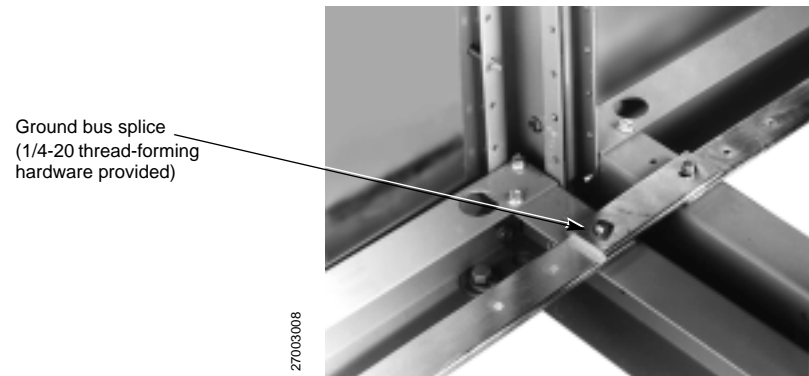

⚠ DANGER

HAZARD OF ELECTRIC SHOCK, EXPLOSION, OR ARC FLASH

- Apply appropriate personal protective equipment (PPE) and follow safe electrical work practices. See NFPA 70E.
- This equipment must be installed and serviced only by qualified personnel.
- Turn off all power supplying this equipment before working on or inside equipment.
- Always use a properly rated voltage sensing device to confirm power is off.
- Replace all devices, doors, and covers before turning on power to this equipment.

Failure to follow these instructions will result in death or serious injury.

Preparing the IPC2™

NOTE: Before joining shipping blocks, ensure the IPC equipment is installed per the Integrated Power Center instruction bulletin no. 80043-056-__.

1. Remove dirt and debris from the foundation and surrounding area before moving the IPC2 enclosure into its final position.
2. After the IPC2 enclosure has been moved to its final installation site, take the equipment off its shipping stringers.

Joining Shipping Sections

1. Remove the side covers from the IPC2™ enclosure to access the vertical support. Open or remove the front doors of the IPC to access the side panels.
2. Position the IPC2 enclosure and IPC sections adjacent to one another, carefully leveling and aligning the rear of each section.

Figure 8: IPC2 and IPC Shipping Sections

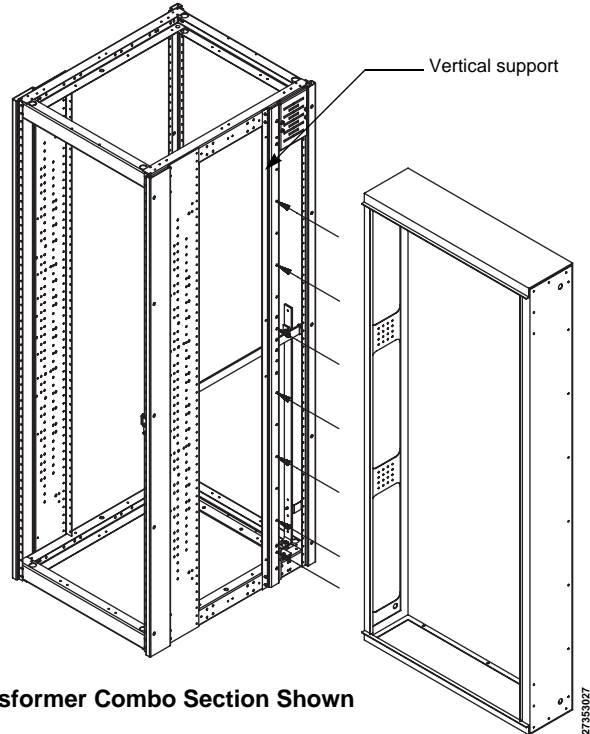

3. Locate and move any factory-installed cables through the side openings into the appropriate sections.
4. Bolts (1/4-20 x 1 inch), washers, and nuts are provided in the IPC structure. Seven sets of hardware will be used to join the sections. Align the section splicing holes in the front of the IPC side panel with the corresponding holes in the IPC2 vertical support.
5. Place the bolts through the holes in the IPC2 vertical support and IPC side panels to join the adjacent sections (Figure 8). Secure each bolt with a washer and nut until the connection is finger-tight.
6. Torque the hardware to 72 lb-in (8 N•m) to complete bolting the sections together.
7. Connect any factory-installed cables per Table 2 on page 31.
8. Replace the side covers on the IPC2 enclosure.

Making Ground Cable Splice Connections

1. Align and secure the ground cable connection between the IPC shipping sections per the *Integrated Power Center* instruction bulletin.
NOTE: Proper installation is essential for equipment ground-fault systems.
2. Locate the ground lug on the ground bar in the IPC2 enclosure.

3. Place the stripped end of the ground cable from the IPC sections into the lug on the IPC2™ ground bar (Figure 9).
4. Torque the ground cable connection per Table 2 on page 31.
5. Replace the IPC door, and reinstall the side covers on the IPC2 enclosure if not already completed.

Figure 9: Ground Splice Connection

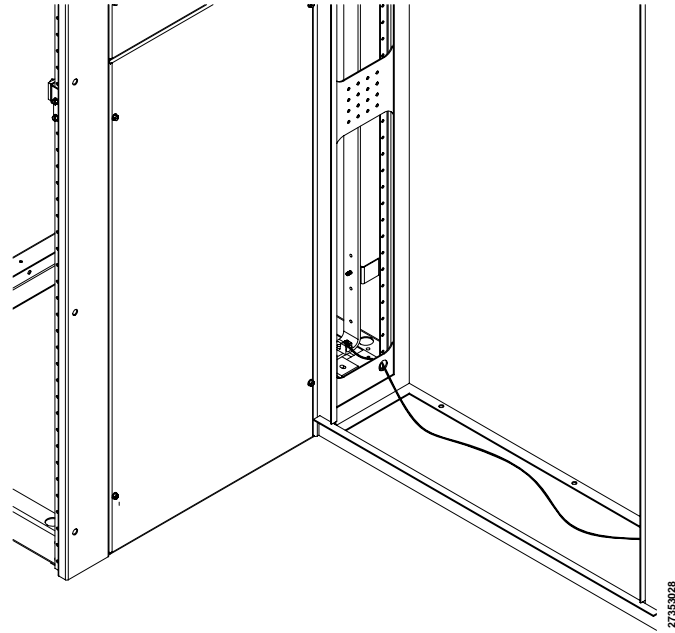

Modular Panelboard System (MPS) and IPC2™
Enclosure Splice

⚠ DANGER

HAZARD OF ELECTRIC SHOCK, EXPLOSION, OR ARC FLASH

- Apply appropriate personal protective equipment (PPE) and follow safe electrical work practices. See NFPA 70E.
- This equipment must be installed and serviced only by qualified personnel.
- Turn off all power supplying this equipment before working on or inside equipment.
- Always use a properly rated voltage sensing device to confirm power is off.
- Replace all devices, doors, and covers before turning on power to this equipment.

Failure to follow these instructions will result in death or serious injury.

Preparing the IPC2

NOTE: Before joining shipping blocks, ensure the MPS equipment is positioned in its final location.

1. Remove dirt and debris from the foundation and surrounding area before moving the IPC2 enclosure into its final position.
2. After the IPC2 enclosure has been moved to its final installation site, take the equipment off its shipping stringers.

Joining Shipping Sections

1. Remove the side covers from the IPC2™ enclosure to access the vertical support. Remove the front covers of the MPS to access the side panels of adjacent sections.
2. Position the IPC2 enclosure and MPS sections adjacent to one another, carefully leveling and aligning the rear of each sections.

Figure 10: IPC2 and MPS Shipping Sections

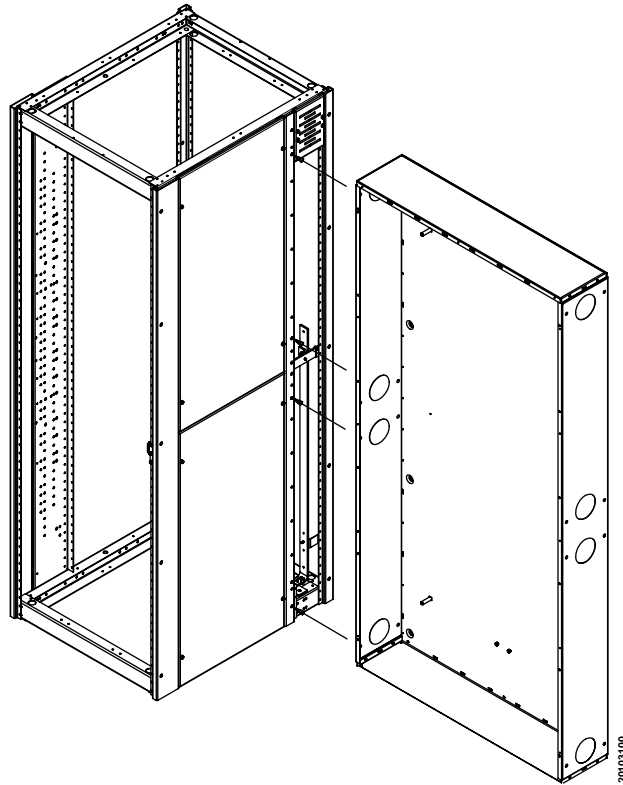

3. Locate and move any factory-installed cables through the side openings into the appropriate sections.
4. Bolts (3/8-16-x 1 inch), washers, and nuts are provided in the MPS structure. Four sets of hardware will be used to join the sections. Align the section splicing holes in the front of the MPS side panel with the corresponding holes in the IPC2 vertical support.
5. Place the bolts through the holes in the IPC2 vertical support and MPS side panels to join the adjacent sections (Figure 10). Secure each bolt with a washer and nut until the connection is finger-tight.
6. Torque the hardware to 72 lb-in (8 N•m) to complete bolting the sections together.
7. Connect any factory-installed cables per Table 2 on page 31.
8. Replace the side covers on the IPC2 enclosure.

Making Ground Cable Splice Connections

1. Run ground cable from the MPS ground bar to the IPC2 enclosure ground bar.

NOTE: Proper installation is essential for equipment ground-fault systems.

2. Locate the ground lug on the ground bar in the IPC2 enclosure.

3. Place the stripped end of the ground cable into the lug on the IPC2™ ground bar (Figure 11).
4. Torque the ground cable connection per Table 2 on page 31.
5. Replace the MPS covers, and reinstall the side covers on the IPC2 enclosure if not already completed.

Figure 11: Ground Splice Connection

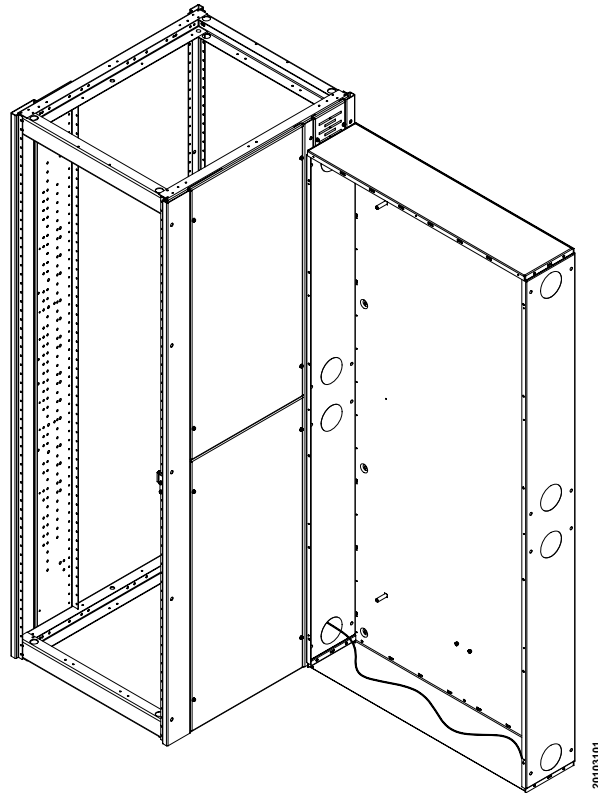

Anchoring the IPC2™ for Seismic Qualifications

IPC2 equipment that is seismically certified has been qualified to the site-specific seismic requirements of the listed model building codes and/or standards. Optional construction features may be required, depending on the location of the installation and the particular code and/or standard of interest. Seismic certificates of compliance are provided with all seismically-certified IPC2 equipment. To maintain the validity of this certification, the installation instructions provided in this bulletin must be followed.

Responsibility for Mitigation of Seismic Damage

For the purposes of the model building codes, IPC2™ equipment is considered as nonstructural building components. Equipment capacity was determined from tri-axial seismic shake table test results as defined in the International Code Counsel Evaluation Service (ICCES) Acceptance Criteria for Seismic Qualification Testing of Nonstructural Components (AC156). Unless otherwise indicated, an equipment importance factor of 1.5 ($I_p = 1.5$) was used, indicating that equipment functionality was verified before and after shaker table seismic simulation testing. This importance factor is indicative of critical facilities where maximizing the probability of post event functionality is a priority. AC156 is published by the ICC ES and has been recognized by the Building Seismic Safety Council (BSSC) as an appropriate methodology in the 2003 National Earthquake Hazard Reduction Program (NEHRP) Commentary (FEMA 450 Part 2). The National Institute of Building Sciences established the BSSC in 1979 to develop and promote regulatory provisions for earthquake risk mitigation at the national level.

Incoming and outgoing cable and conduit must also be considered as related but independent systems. They must be designed and restrained to withstand the forces generated by the seismic event without increasing the load transferred to the equipment. For applications where seismic hazard exists, bottom entry and/or exit of cable and conduit is preferred. This system must be capable of transferring the loads created to the load-bearing path of the building structural system.

Maintaining Seismic Certification

Seismic qualification of nonstructural components by Schneider Electric is just one link in the total chain of responsibility required to maximize the probability that the equipment will be intact and functional after a seismic event. During a seismic event, the equipment must be able to transfer the loads that are created through the mounting pad and anchorage to the load-bearing path of the building structural system.

The structural civil engineer or design engineer of record is responsible for detailing the equipment connection and anchorage requirements for the given installation. The installer and manufacturers of the anchorage restraint system are responsible for assuring that the mounting requirements are met. Schneider Electric is not responsible for the specification and performance of these systems.

Anchoring IPC2 for Seismic Applications

Formed base channels run the width of the section. The channels and connecting braces provide a .75-in. (19 mm) diameter hole for fastening the section to the floor. To properly anchor the IPC2 to the floor, use all four mounting locations. Use ½-in. (12.7mm) diameter anchor bolts (Grade 5 minimum) for the installation of equipment. Use one 1.25-in (31.75 mm) outer diameter Grade 5 belleville washer (Square D part no. 23903-33201, supplied with the IPC2 equipment) under the head of each bolt or anchor nut. To develop full strength of the anchor, torque the hardware to the value specified by the anchor manufacturer or seismic restraint detailing supplied by the Structural Civil Engineer of record for the project.

Additionally, each NEMA 1 enclosed section includes two rear top-located lifting angles with a 1.25-in. (31.75 mm) diameter hole that may be used for upper structural restraint.

Top structural restraint is required for all IPC2 equipment installed:

- where the site specific 0.2 second spectral ground motion exceeds 2.67 g's (as determined from the code referenced ground motion maps or the site specific seismic hazard engineering study),
- or when displacement at the top of the equipment cannot be tolerated.

To develop full strength of the upper structural anchor, install and torque the hardware as specified by the anchor manufacturer or seismic restraint detailing supplied by the Structural Civil Engineer of record for the project.

NOTE: Most of the anchoring hardware is not furnished with the IPC2™ equipment, with the exception of the Grade 5 belleville washer (Square D part no. 23903-33201) mentioned above.

After the IPC2 and adjacent equipment are properly joined together and the entire structure is bolted to the floor, install the incoming service conductors and load side cables. During an earthquake, the top of the IPC2 can move in any direction. Any top incoming cables must accommodate this motion. The IPC2 enclosure (particularly the top) should not be used to mount exterior equipment.

Anchoring the IPC2™

Although sections are freestanding, a hard bump or shifting movement can result in damage to the splice joints between sections and conduit hubs connected to the sections. Therefore, each vertical section must be anchored to the floor.

Formed base channels run the width of the shipping section. For fastening the section to the floors, the channels have .75 in.- (19 mm) diameter holes for seismic applications or 1.12-in. (28 mm) diameter holes for non-seismic applications (see Figure 12 below). Anchor each section to the floor with 1/2-in. diameter (Grade 2 minimum) bolts with flat washers and anchors suitable for installation of electrical equipment (not furnished).

Figure 12: IPC2 Base Channels

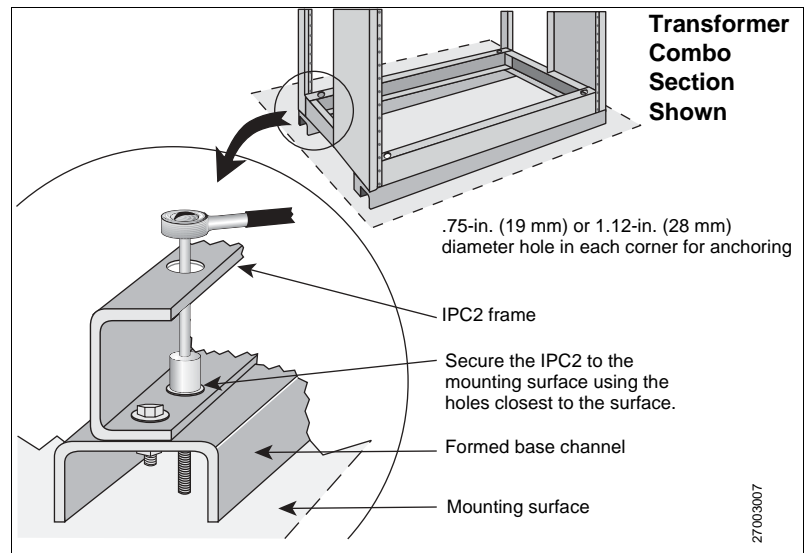

After all equipment sections are properly joined together and the entire structure is bolted to the floor, install the incoming service conductors and load side cables.

Grounding and Bonding

NOTE: A system is “grounded” if it is grounded at any point ahead of the IPC2, whether the grounded conductor (neutral) is carried through to the loads, or not.

Service Equipment—Grounded System

For solidly *grounded* systems used as either service equipment or as a main IPC2 on a separately derived system:

Figure 13: Grounding Electrode Connector

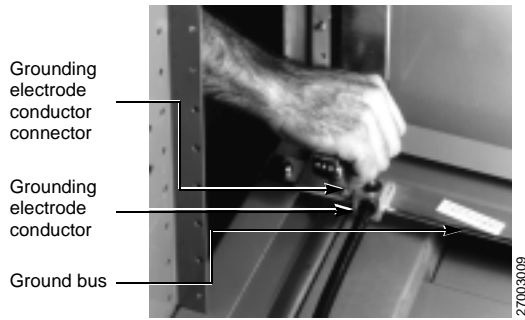

1. Run a grounding electrode conductor from the grounding electrode at the installation site to the grounding electrode conductor connector (ground lug) located on the IPC2™ ground bus (Figure 13). Select the material and size of this grounding electrode conductor to comply with Sections 250-62 and 250-66 of the NEC® or Sections 10-204 and 10-206 of the CEC, and install it as specified in Section 250-64 of the NEC or Section 10-908 of the CEC.
2. Install the main bonding jumper (provided with the IPC2) between the neutral assembly of the service entrance panelboard located in the IPC2 equipment and a ground lug located on the IPC2 unit ground bus. For torque values, refer to Table 2 on page 31.

NOTE: If the IPC2 is fed from multiple sources (for example, double-ended systems), there may be two or more main bonding jumpers to install.

In Canada, a main bonding jumper cable is provided between the neutral assembly and ground bus. When disconnection of the bonding jumper is required (for example, for a Megger® test), remove the cable lug with cable from the neutral assembly. This is normally located near the line neutral lugs. Secure the cable and lug to maintain the required distance from phases and neutral.

NOTE: If the IPC2™ is fed from multiple sources (for example, a double-ended system like a main-tie-main), there may be two or more main bonding jumpers installed.

Service Equipment—Ungrounded System

For *ungrounded* systems used as either service equipment, or as a main IPC2 on a separately derived system:

1. Run a grounding electrode conductor from the grounding electrode at the installation site to the grounding electrode conductor connector (ground lug) located on the IPC2 ground bus (Figure 13).
2. Select the material and size of this grounding electrode conductor to comply with Sections 250-62 and 250-66 of the NEC® or Sections 10-700 and 10-702 of the CEC, and install it as specified in Section 250-64 of the NEC or Section 10-204 of the CEC.

Not Service Equipment

For either *grounded* or *ungrounded* systems, when an IPC2 is used neither as service equipment, nor as a main IPC2 on a separately derived system:

Use equipment grounding conductors sized according to Section 250-122 of the NEC or Section 10-206 of the CEC to connect the IPC2 frame and ground bus to the service ground.

High-Impedance Grounded Neutral Systems

For high-impedance grounded neutral systems:

Ground the system following the instructions provided with the system grounding equipment and in compliance with Section 250-36 of the NEC. Confirm that the IPC2 frame and ground bus are bonded in accordance with Section 250-102 of the NEC.

Conduit Area

1. Locate and terminate all conduit in the IPC2 enclosure in the “available conduit area” designated on the equipment drawing.
 - a. When cables are entering the top of the IPC2, remove the IPC2 top plate and retain the hardware for reuse.
 - b. Add cutouts in the top plate as needed. Ensure no metal shavings are allowed to fall into the IPC2.
 - c. Re-install the top plate and secure it with the hardware retained in step a.

2. Install the conduit properly. Use hubs and ring connectors to protect the cables and prevent condensation on the conduit from entering the IPC2™.

NOTE: If top entry, do not use the top of the IPC2 to support the weight of the conduit. Support the conduit independently.

Under seismic conditions, the top of the IPC2 can move as much as 3.00 in. (76 mm) in any direction. Any top incoming cables must accommodate this motion.

3. Bond all conduit, stubs, and ring connectors to the IPC2 enclosure with approved electrical connections.

Cable Pulling

IPC2 units are constructed to customer specifications for the cable entrance arrangement (for example, top or bottom feed). IPC2 components are arranged to give proper cable clearance and bending space for cables entering or exiting the IPC2 as specified on the equipment drawing.

1. Use only cable sizes suitable for a proper fit with the corresponding lugs.
2. Pull the proper number of line side and load side cables according to the load served and the NEC or CEC.
3. Position the cables inside the IPC2 so that they are not subject to physical damage.
4. Maintain the maximum possible bending radii and proper clearance to bus bars and grounded parts. If any cables are lying or bearing on structural members, support them to relieve this condition or place suitable protective material at the bearing point to protect the cable insulation.

Additionally, when it is necessary to route feeder cables through the Transformer Combo transformer compartment, the installer must reliably route the cables as to ensure there is no direct contact between the cables and the transformer core or coils. **Do not** route cables directly over the transformer core or coils. Use of the cable support brackets on each side of the structure is recommended.

5. **Be certain to run all phase conductors, including the neutral, through the same opening where cables enter or leave the IPC2™, or pass through any metal that has magnetic properties. Otherwise, overheating can result. See Section 300-20(a) of NEC®.**
6. When instructed, brace or cable-lace the conductors.

Cable Terminations

1. Use a proper insulation stripping tool to strip a length of insulation from the end of the cable sufficient to fit into the full length of the lug barrel. Be careful not to nick or ring the strands.
2. Thoroughly clean aluminum cable contact surfaces with a wire brush, or scrub them with an abrasive cloth to remove oxides and foreign matter.
3. Immediately apply an acceptable joint compound to the bare aluminum surfaces.

4. If compression-type lugs are furnished, unbolt and remove them to create sufficient room for crimping the lugs to the cables with the crimping tool.
 - a. Insert the cable into the lug barrel and, using the crimping tool, make the specified number of crimps per the manufacturer's recommendations.
 - b. Wipe excess joint compound from the connector and insulation.
 - c. With the cables connected, remount the lugs onto the bus bars or circuit breakers. Torque the bolts to the values given in "Section 9—Torque Values for Electrical Connections" on pages 31 and 32.
5. Set screw-type lugs may be furnished as main incoming lugs and are standard on molded case circuit breakers. Torque these lugs **to, but do not exceed**, the specified values. Torque values for circuit breaker lugs are marked on these units. Torque values for other IPC2™ lugs are marked on the IPC2.

Ground-Fault Protection for Equipment

▲ WARNING
LOSS OF EQUIPMENT GROUND-FAULT PROTECTION
Do not connect grounding conductors to any load neutral terminal(s).
Failure to follow this instruction can result in death or serious injury.

According to Section 230-95(c) of the NEC, "The ground-fault protection system shall be performance tested when first installed . . . A written record of this test shall be made and shall be available to the authority having jurisdiction."

Schneider Electric tests the factory-installed ground-fault system prior to shipment. However, improper grounding of the IPC2 and devices downstream at the job site will defeat the ground-fault system. Performance testing of the ground-fault system, as stated in the NEC, requires injecting sufficient current into the system to test the ground fault. High current injection by a certified testing organization will test the polarity of the ground-fault sensors, interconnection wiring, and proper bonding of the neutral.

NOTE: Some equipment ground-fault systems require field connections at the job site. Consult the IPC2 interconnection wiring drawing for details.

SECTION 5—PRE-ENERGIZING CHECKOUT PROCEDURE

Conduct a complete inspection **before** the IPC2™ is energized to ensure that all components function and operate properly. **Complete every step of the checkout procedure listed before energizing the IPC2.**

1. Check the ground bus bar connections. Torque values are listed in Table 2 on page 31.
2. Check all accessible connections for tightness.
3. Check all factory- and field-installed lug terminations for tightness.
4. Check the IPC2 enclosure for dents or other damage that reduces electrical clearances inside the IPC2.
5. Remove all foam blocks, or other temporary cushioning or retaining material, from the electrical devices.
6. Manually open and close all switches, circuit breakers, and other operating mechanisms, checking for correct alignment and free operation.
7. Operate all electrically operated switches, circuit breakers, and other devices equipped with remote operators (not under load). An auxiliary source of control power may be necessary to accomplish this.
8. Check all relays, meters, and instrumentation to verify that all field- installed wiring connections are made properly and that the devices function properly.
9. Current transformers (CTs) supplied for customer use require connection to a metering device load before energizing. Verify that the metering device load is properly connected, including main IPC2 connections to remote equipment.
10. All CT circuits supplied by Schneider Electric for customer metering use are shorted for shipment. Remove shorting terminal screws on shorting terminal blocks or jumpers and store in the block.
11. Factory-installed molded case circuit breakers, 250 A frames or larger, may have an adjustable magnetic trip, which is shipped on the “LO” setting. The markings between “LO” and “HI” settings represent a range of instantaneous magnetic trip values of 5–10 times the circuit breaker’s continuous current rating. To provide coordinated operation during a fault, adjust the magnetic trip as outlined in the respective instruction bulletin. All poles are adjusted simultaneously, using a screwdriver, by the single setting (Figure 14).
12. On IPC2 units containing an electronic trip circuit breaker, set the tripping characteristic curve of the adjustable electronic trip unit per the job requirements, or as outlined in the respective instruction bulletin.
13. If ground-fault protection is furnished on molded case circuit breakers, refer to “Section 11—Reference Publications” on page 34 for information to obtain circuit breaker publications.
14. Inspect all cables to ensure the insulation has not been damaged in any fashion.
15. Verify that all grounding connections are correctly made. If the IPC2 is used as a service entrance, double check to see that the main bonding jumper is connected.

Figure 14: Instantaneous Trip Setting

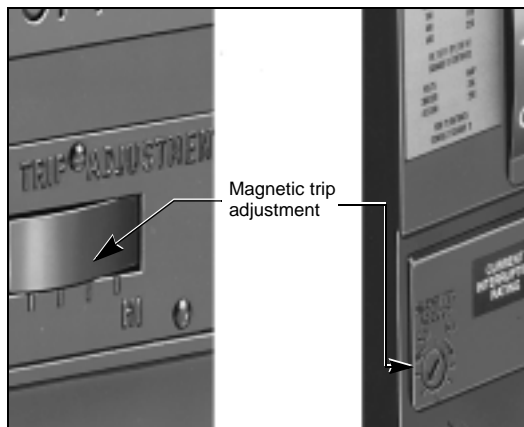

CAUTION

HAZARD OF EQUIPMENT DAMAGE

Do not pry open or spread the fuse mounting clips. This can cause a loose connection, resulting in overheating.

Failure to follow this instruction can result in equipment damage.

16. Conduct an electrical insulation resistance (Megger®) test to ensure that the IPC2™ is free from short circuits and undesirable grounds.
 - a. Open all control power and metering disconnects or remove the fuses from the control circuits.
 - b. Disconnect the neutral connection at any TVSS or other electronic device prior to performing the electrical insulation resistance test; reconnect to the device after the test.
 - c. With the neutral isolated from the ground and the power switches and circuit breakers open, conduct electrical insulation tests from phase-to-phase, phase-to-ground, phase-to-neutral, and neutral-to-ground. If the resistance reads less than one megohm while testing with the branch circuit breaker devices in the open position, the system may be unsafe and should be investigated. Consult Square D Services at 1-888-778-2733 (US) or 1-800-265-3374 (Canada) to help correct any problems.
17. Record resistance values. See “Section 10—IPC2™ Power Center Insulation Resistance Chart” on page 33.
18. After completing the electrical insulation resistance test, replace all control power fuses that may have been removed, and close power disconnects that have been opened.
19. Check all field-installed wiring. Make certain it is clear of all live parts, and when instructed, secured to withstand fault currents.

NOTE: MG-, MJ-, P-, and R-frame circuit breakers require cable lacing within the IPC2 unit. Follow lacing instructions provided with these circuit breakers.
20. Verify that all control wiring between sections is connected.
21. Vacuum to remove any dust, scrap wire, or other debris.
22. Replace all covers; check for any pinched wires, and close doors. Make certain all enclosure parts are aligned properly and securely fastened.

⚠ CAUTION
HAZARD OF EQUIPMENT DAMAGE OR INJURY
<ul style="list-style-type: none">• Remove the long-time rating plug before electrical insulation testing a circuit breaker that has a label stating “Warning: Disconnect Plug Before Dielectric Test.”• Some Micrologic® trip units are not rated for voltages that would occur during electrical resistance insulation testing.• Open all control and metering disconnects from the control circuits.
Failure to follow these instructions can result in injury or equipment damage.

CAUTION
HAZARD OF EQUIPMENT DAMAGE
Do not use an air hose to blow out the IPC2. The dust may settle inside relays and overcurrent devices, causing overheating and improper operation.
Failure to follow this instruction can result in equipment damage.

SECTION 6—ENERGIZING THE IPC2™

⚠ DANGER

HAZARD OF ELECTRIC SHOCK, EXPLOSION, OR ARC FLASH

- Correct short-circuit conditions detected during the checkout procedures described in “Section 5—Pre-Energizing Checkout Procedure”, beginning on page 24.
- Qualified electrical personnel must be present when energizing this equipment for the first time.
- Follow the instructions in this section to properly energize the IPC2™.

Failure to follow these instructions will result in death or serious injury.

1. No load should be on the IPC2 when it is energized. Turn off all downstream loads.
2. Energize the IPC2 in the following sequence:
 - a. Turn on all control power disconnects before energizing the IPC2. Refer to the record drawings supplied with equipment to see if control power disconnects are supplied.
 - b. Close any open doors and/or covers.
 - c. Close the main device(s).
 - d. Close each branch circuit breaker or branch fusible switch.
 - e. Proceed to each panelboard and other downstream load.
3. After all overcurrent protective devices are closed, turn on all loads (e.g., lighting circuits, contactors, heaters, and motors).

SECTION 7—MAINTAINING THE IPC2™

⚠ DANGER

HAZARD OF ELECTRIC SHOCK, EXPLOSION, OR ARC FLASH

- Apply appropriate personal protective equipment (PPE) and follow safe electrical work practices. See NFPA 70E.
- Inspect and perform preventive maintenance only on IPC2 equipment to which power has been turned to the OFF position, disconnected, and electrically isolated (unless otherwise specified) so that no accidental contact can be made with energized parts.

Failure to follow these instructions will result in death or serious injury.

Periodic maintenance of the IPC2 includes cleaning, lubrication, and exercising component parts. The interval between maintenance checks can vary depending upon the amount of usage and environmental conditions of each installation. The maximum recommended inspection interval is one year. This definition for periodic maintenance applies throughout this bulletin, unless otherwise noted.

Always inspect the IPC2 after a fault. (Refer to “Section 8—Adverse Circumstances”, beginning on page 29.) Service bulletins for the various disconnecting and overcurrent devices mounted in the IPC2 are available through your local Schneider Electric field office.

General Inspection and Cleaning

1. Turn off all power supplying this equipment before working on or inside equipment.
2. Always use a properly rated voltage sensing device to confirm all power is off.
3. Vacuum the IPC2 interior to remove any dirt or dust deposits. Wipe all bus bars, insulators, cables, etc., with a clean, dry, lint-free cloth.

CAUTION
HAZARD OF EQUIPMENT DAMAGE
<ul style="list-style-type: none">• Do not use an air hose to blow out the IPC2. The dust may settle inside relays and overcurrent devices, causing overheating and improper operation.• Do not allow paint, chemicals, or petroleum-based solvents to contact plastics or insulating materials.
Failure to follow these instructions can result in equipment damage.

Panel Bus Bar Joints, Lug Terminations, and Insulating Materials

CAUTION
HAZARD OF EQUIPMENT DAMAGE
<ul style="list-style-type: none">• Do not sand or remove plating on any bus bar, splice bar, or terminal lug.• Damage to plating can result in overheating. Replace damaged part. Contact Square D Services at 1-888-778-2733 (US) or 1-800-265-3374 (Canada).
Failure to follow these instructions can result in equipment damage.

General Lubrication Information

Automatic Transfer Switches

4. Check the IPC2™ interior carefully for moisture, condensation build-up, or signs of any previous wetness. Moisture can cause insulation failures and rapid oxidation of current-carrying parts. Inspect all conduit entrances and cracks between the enclosure panels for dripping leaks. Condensation in conduits may be a source of moisture and must not be allowed to drip onto live parts or insulating material. Take the necessary steps to eliminate the moisture and seal off all leaks.
5. Inspect the IPC2 for any signs of overheating. Discoloration, flaking, and cracking of insulation or metal parts are indications of overheating. Inspection of the cable insulation within the Transformer Combo transformer compartment is imperative.
NOTE: If overheating occurs, be sure that all conditions that caused the overheating have been corrected. Loose or contaminated connections can cause overheating.
6. Check for signs of rodent nesting in the IPC2. If required, use a good exterminating technique in the general area of the IPC2.
NOTE: Do not place or use exterminating substances and chemicals inside the IPC2. Some of these products attract rodents.
7. Carefully inspect all devices for any visibly worn-out, cracked, or missing parts.
8. Manually open and close switches and circuit breakers several times to verify they are working properly.
9. Verify that all locking mechanisms are working properly.

1. Do not retighten panel bus bar joints after the pre-energizing checkout procedure is complete.
2. Check all panel bus bar joints and terminal lugs for any pitting, corrosion, or discoloration resulting from high temperatures or subjection to high fault conditions. If any damage has occurred, contact Square D Services in the US at 1-888-Square D (1-888-778-2733) or in Canada at 1-800-265-3374 to help correct any problems. If cleaning is required, use Lectra-Clean®, made by CRC Industries, Inc.
3. Inspect all insulating materials. Before re-energizing the IPC2, replace insulators with any visible damage (such as cracks).

For field maintenance re-lubrication of bus/plug-on connections, use Schneider Electric catalog number PJC7201 (Electric Joint Compound).

Consult the manufacturer's bulletin about these devices for all installation, operation, and maintenance instructions.

Circuit Breakers

⚠ DANGER

HAZARD OF ELECTRIC SHOCK, EXPLOSION, OR ARC FLASH

- If circuit breaker settings are adjusted, do not set the long time trip rating at a higher ampacity than the rating of the bus bar or load cables it supplies; overheating can occur.
- Before energizing the IPC2™, all unused circuit breaker mounting spaces must be filled with blank fillers and/or extensions as listed in Table 1.

Failure to follow these instructions will result in death or serious injury.

CAUTION

HAZARD OF EQUIPMENT DAMAGE

- Do not remove the protective lubricant on the plug-on connectors.
- If additional lubrication is required, apply a coating of electrical joint compound, catalog number PJC7201, to the plug-on connector's contact surfaces.

Failure to follow these instructions can result in equipment damage.

Schneider Electric circuit breakers are designed and manufactured as totally sealed units requiring minimal periodic maintenance.

Exercise circuit breakers at least once a year to ensure proper operation. For general maintenance:

1. Trip the circuit breaker by pushing the Push-To-Trip or "Open" button located on the face of the circuit breaker. Refer to the appropriate circuit breaker bulletin for the specific location of this button.
2. Manually open and close the circuit breaker two to three times.

NOTES:

- *Schneider Electric bulletin 0600DB9901 "Field Testing and Maintenance Guide for Micrologic® Electronic Trip and Thermal-magnetic Molded Case Circuit Breakers" provides more in-depth information. Refer to "Section 11—Reference Publications" on page 34 and contact your local Schneider Electric field office to obtain this bulletin.*
- *Refer to individual circuit breaker instruction bulletins shipped with the IPC2™ for additional maintenance information, such as changing rating columns or adjustable settings and removing circuit breakers. If the instruction bulletins are not available, see "Section 11—Reference Publications" on page 34, and contact your local Schneider Electric field office for information to obtain the appropriate bulletins.*

Table 1: Blank Fillers and Extensions

	Height	Catalog No.
NF Filler Plate	1.00 in (25 mm)	EFP
NQOD Filler Plate	0.75 in (19 mm)	QOFP
I-Line® Blank Fillers	1.50 in (38 mm)	HNM1BL
	4.50 in (114 mm)	HNM4BL
I-Line Blank Extensions	1.50 in (38 mm)	HLW1BL
	4.50 in (114 mm)	HLW4BL

3. The universal test set, Schneider Electric catalog number UTS3, is available to test all Schneider Electric circuit breakers equipped with Micrologic® trip units. It runs trip unit tests automatically, with prompts to the user for initial information. Test modules for each circuit breaker frame are used to store data necessary for automatic tests. Series B Micrologic trip units require test module CBTMB, which is included in UTS3.

Masterpact® and Powerpact® circuit breakers with Micrologic trip units require the full-function test set (catalog no. 533595) or hand-held test set (catalog no. 533594).

NOTE: Tests may be conducted with a circuit breaker installed in the IPC2; removing the circuit breaker is not required. The IPC2 must be de-energized.

Ground-Fault Protection for Equipment

Check the terminal connections on the equipment ground-fault protection system at least once a year for tightness and corrosion. If the system can be tested with or without tripping the main or branch device, directions for testing the system are in the device bulletin. Otherwise, testing the equipment ground-fault protection system will trip the main or branch device to which it is connected. If the equipment ground-fault sensor or relay is physically or electrically damaged, replace it.

If the ground-fault protection system does not operate properly and additional equipment has been connected to the installation since the last maintenance test/check, de-energize the entire system and check for grounds on the neutral downstream from the main bonding jumper. If no downstream grounds are detected and the equipment ground-fault system is not operating properly, contact Square D Services in the US at 1-888-Square D (1-888-778-2733) or in Canada at 1-800-265-3374.

Refer to Schneider Electric bulletin 0600DB9901 *“Field Testing and Maintenance Guide for Micrologic® Electronic Trip and Thermal-magnetic Molded Case Circuit Breakers”* for additional testing information. If the bulletin is not available, refer to “Section 11—Reference Publications” on page 34 and contact your local Schneider Electric field office to obtain the bulletin.

Other Manufacturers’ Devices

Consult the manufacturers’ bulletins about these devices for all installation, operation, and maintenance instructions.

SECTION 8—ADVERSE CIRCUMSTANCES

This section includes, but is not limited to, all electrical components of the IPC2™.

<p style="text-align: center;">⚠ DANGER</p> <p>HAZARD OF ELECTRIC SHOCK, EXPLOSION, OR ARC FLASH</p> <ul style="list-style-type: none">• Apply appropriate personal protective equipment (PPE) and follow safe electrical work practices. See NFPA 70E.• Turn off all power supplying this equipment before working on or inside the equipment.• Always use a properly rated voltage sensing device to confirm all power is off.• Before energizing the IPC2, all unused circuit breaker mounting spaces must be filled. <p>Failure to follow these instructions will result in death or serious injury.</p>
--

NOTE: Before attempting to re-energize the IPC2 following an adverse circumstance, contact Square D Services in the US at 1-888-Square D (1-888-778-2733) or in Canada at 1-800-265-3374, for special instructions.

Inspection Following a Short Circuit

High mechanical and thermal stresses developed by short circuit currents may damage conductors and insulation. If a short circuit occurs, make a thorough inspection of the entire system and verify that no damage to conductors or insulation has occurred. Check the overcurrent protection device that interrupted the short circuit current for possible arcing damage.

Do not open sealed devices, such as molded case circuit breakers. These devices should be replaced if damaged. Before energizing the IPC2, all unused circuit breaker mounting spaces must be filled. For more information about these devices and to obtain the appropriate bulletin, refer to “Section 11—Reference Publications” on page 34.

Clean-up Following a Short Circuit

The insulating properties of some organic insulating materials may deteriorate during an electrical arc. If so:

1. Remove any soot or debris.
2. Replace carbon-tracked insulation.

Water-Soaked Equipment

Do not clean or repair an IPC2™ that has been exposed to large volumes of water or submerged at any time. Current-carrying parts, insulation systems, and electrical components may be damaged beyond repair. Do not energize the IPC2. Contact Square D Services.

Water-Sprayed or Splashed Equipment (Clean Water Only)

⚠ DANGER

HAZARD OF ELECTRIC SHOCK, EXPLOSION, OR ARC FLASH

- Apply appropriate personal protective equipment (PPE) and follow safe electrical work practices. See NFPA 70E.
- Turn off all power supplying this equipment before working on or inside the equipment.
- Always use a properly rated voltage sensing device to confirm all power is off.

Failure to follow these instructions will result in death or serious injury.

Inspection and Clean-up of Clean Water Sprayed or Splashed Equipment

⚠ CAUTION

HAZARD OF EQUIPMENT DAMAGE OR INJURY

- Remove the long-time rating plug before electrical insulation testing a circuit breaker that has a label stating “Warning: Disconnect Plug Before Dielectric Test.”
- Some Micrologic trip units are not rated for voltages that would occur during electrical resistance insulation testing.
- Open all control and metering disconnects from the control circuits.

Failure to follow these instructions can result in injury or equipment damage.

If the IPC2 has been sprayed or splashed with small amounts of clean water, make a thorough inspection of the entire system and verify that no damage to conductors or insulation has occurred. Do not open sealed devices such as molded case circuit breakers or fuses. These devices should be replaced if damaged. For more information about these devices and to obtain the appropriate instruction bulletin, refer to “Section 11—Reference Publications” on page 34.

Follow the steps below only if:

- No signs of physical damage to the equipment are present.
- The IPC2 has not been submerged or exposed to water for long periods of time.
- The water that has been in contact with the IPC2 has not been contaminated with sewage, chemicals, or other substances that can negatively affect the integrity of the electrical equipment.
- The water that has been in contact with the IPC2 has not entered any area of the enclosure that may contain wiring located above any live part. Specifically, inspect for water entering through conduits located above live parts.

If any of these conditions have not been met, contact Square D Services in the US at 1-888-Square D (1-888-778-2733) or in Canada at 1-800-265-3374.

1. Turn off all power supplying this equipment before working on or inside the equipment.
2. Always use a properly rated voltage sensing device to confirm all power is off.
3. Disconnect and electrically isolate the IPC2 so no contact can be made with energized parts.
4. Wipe off all moisture from the panel bus, insulators, and insulating material with a clean, dry, lint-free cloth. Do not use cleaning agents or water displacement sprays.
5. Prepare the IPC2 for insulation resistance (Megger®) testing by disconnecting all line-side supply connections and all load-side cable connections to isolate the IPC2 from the wiring system.
6. Turn all circuit breakers or switches to the ON position. The IPC2 must remain completely de-energized.
7. Use a megohmmeter with a capacity of 500–1,000 Vdc, and apply voltage from:
 - a. each phase-to-ground with circuit breaker on
 - b. phase-to-phase with circuit breaker on

8. Record resistance values. See “Section 10—IPC2™ Power Center Insulation Resistance Chart” on page 33.
9. If resistance measurements are less than 1.0 megohm, call Square D Services for recommendations.
10. If resistance measurements are greater than 1.0 megohm, the equipment can be energized using the procedures listed in “Section 6—Energizing the IPC2™” on page 26.

SECTION 9—TORQUE VALUES FOR ELECTRICAL CONNECTIONS

Table 2: Incoming, Branch, Neutral, and Ground Lugs

Socket Size Across Flats	Torque Value
1/8 in.	45 lb-in (5 N•m)
5/32 in.	100 lb-in (11 N•m)
3/16 in.	120 lb-in (13 N•m)
7/32 in.	150 lb-in (17 N•m)
1/4 in.	200 lb-in (23 N•m)
5/16 in.	275 lb-in (31 N•m)
3/8 in.	375 lb-in (42 N•m)
1/2 in.*	500 lb-in (56 N•m)
9/16 in.	600 lb-in (68 N•m)

* 1/2 in. lug marked with 620 lb-in should be torqued as such.

Table 3: Multiple Conductor Neutral and/or Ground Terminal

Screw Type	Lug Wire Range	Conductor Size	Torque Value
Slotted Head	14–4	14-10 Cu, 12-10 Al	20 lb-in (2 N•m)
		8 Cu-Al	25 lb-in (3 N•m)
		6-4 Cu-Al	35 lb-in (4 N•m)
	14–1/0	14-8 Cu-Al	36 lb-in (4 N•m)
6-1/0 Cu-Al		45 lb-in (5 N•m)	
Socket Head	14–1/0	All	100 lb-in (11 N•m)
	6–300 kcmil	All	275 lb-in (31 N•m)

Table 4: Contactors, Terminal Block Conductor, and Torque Data

Device	Conductor Type	Lug Torque
Square D Class 8903 Contactor Types		
LO/LX 20—1200	Cu only, 75° C rated minimum	20 lb-in (2 N•m)
SMO1, 2, 3, 4, 10, 11, 12, 13		20 lb-in (2 N•m)
SVO1, 2, 3, 4, 10, 11, 12	Cu–Al, 75° C rated minimum	275 lb-in (31 N•m)
SPO1, 2, 3, 4, 10, 11, 12, 13		50 lb-in (6 N•m)
SQO1, 2, 3, 4, 10, 11, 12, 13		80 lb-in (9 N•m)
Square D Class 8910 Contactor Types		
DPA 32, 33, 34	Cu only, 75° C rated minimum	18 lb-in (2 N•m)
Square D Class 9080 Terminal Blocks		
GR6	Cu only, 75° C rated minimum	18–20 lb-in (2 N•m)
GC6		32–35 lb-in (4 N•m)

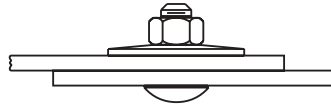

Carriage bolt
 Hex nut
 Conical washer

Hardware Description	Torque Value
1/2 in.	720–840 lb-in (81–95 N•m)

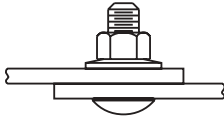

Carriage bolt
 Conical washer assembly
 (Keps nut)

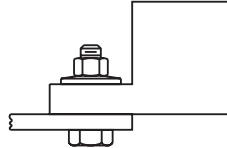

Hex head bolt
 Conical washer assembly
 (Keps nut)

Hardware Description	Torque Value
1/4 in.	50–75 lb-in (6–8 N•m)
5/16 in.	80–125 lb-in (9–14 N•m)
3/8 in.	175–225 lb-in (20–25 N•m)
1/2 in.	250–350 lb-in (28–40 N•m)

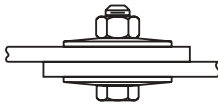

Hex head bolt
 (2) Conical washers

Hardware Description	Torque Value	
	Conical Washer OD	Hex Head Bolt (2) Conical Washers
5/16 in.	0.90 in. (23 mm)	145–160 lb-in (16–18 N•m)
	0.87 in. (22 mm)	250–280 lb-in (28–32 N•m)
3/8 in.	1.00 in. (25 mm)	130–150 lb-in (15–17 N•m)
	1.25 in. (32 mm)	
1/2 in.	2.25 in. (57 mm)	720–840 lb-in (81–95 N•m)
	3.00 in. (76 mm)	

SECTION 11—REFERENCE PUBLICATIONS

Schneider Electric publications are available through your local Schneider Electric field office. These publications include device replacement procedures and spare parts listings to make ordering and servicing of replacement parts quick and convenient.

Contact the nearest Schneider Electric field office for information in the US at 1-888-Square D (1-888-778-2733) or in Canada at 1-800-265-3374. Or, refer to the Technical Library at <http://ecatalog.squared.com/techlib/> to obtain the appropriate publications.

For information about obtaining NEMA documents, write to:

National Electrical Manufacturers Association (NEMA)
Attention: Customer Service
1300 North 17th Street
Suite 1847
Rosslyn, VA 22209

Other Reference Publications	Publication Number
General Instructions for Proper Installation, Operation, and Maintenance of Switchboards Rated 600 V or Less	NEMA Publication PB2.1
Application Guide for Ground-Fault Protective Devices for Equipment	NEMA Publication PB2.2
Circuit Breakers	NEMA Publication AB-4
Enclosed and Miscellaneous Distribution Switches	NEMA Publication KS-1
Electrical Equipment Maintenance	NFPA 70B-1999

**Integrated Power Center 2 (IPC2™)
Instruction Bulletin**

Schneider Electric USA

Square D, Integrated Power
and Control Solutions
105 Summit Park Drive
Salisbury, NC 28146 USA
1-800-868-9662
www.us.SquareD.com/ipacs

Electrical equipment should be installed, operated, serviced, and maintained only by qualified personnel. No responsibility is assumed by Schneider Electric for any consequences arising out of the use of this material.

80043-708-02 © 2005–2006 Schneider Electric All Rights Reserved
Replaces 80043-708-01, 08/2005

07/2006