

# Preventa™ Safety Switches Type XCSDM

Catalog Supplement to 9007CT0201  
2009



**Schneider**  
Electric



---

## Non-contact safety interlock switches

### Non-contact safety interlock switches

- Presentation, General characteristics . . . . . 2
- Plastic,
  - pre-cabled . . . . . 4
  - connector on pigtail . . . . . 5
- Accessories. . . . . 6

### Non-contact safety interlock systems

- Presentation, General characteristics . . . . . 14
- Plastic, solid-state PNP type output,
  - Pre-cabled connection . . . . . 16
  - M12 connector connection . . . . . 17
- Accessories. . . . . 18

Schneider Electric ®, the Schneider Electric logo, and Preventa™ are trademarks or registered trademarks of Schneider Electric.  
Other trademarks used herein are the property of their respective owners.

# Safety detection solutions

## Non-contact safety interlock switches

Plastic

### XCSDMC

Rectangular, compact: 2.01 x 0.63 x 0.28 in (51 x 16 x 7 mm)

Pre-cabled connection

Connector on pigtail connection

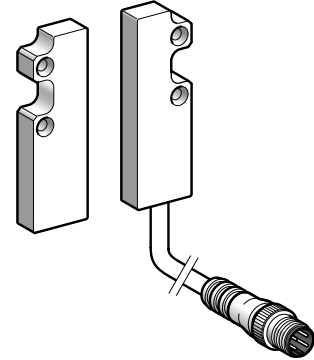
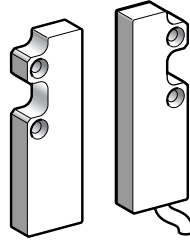

Pages 4 and 5

### XCSDMP

Rectangular, standard: 3.46 x 0.98 x 0.51 in (88 x 25 x 13 mm)

Pre-cabled connection

Connector on pigtail connection

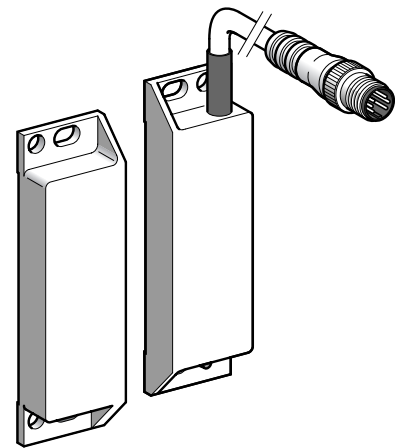
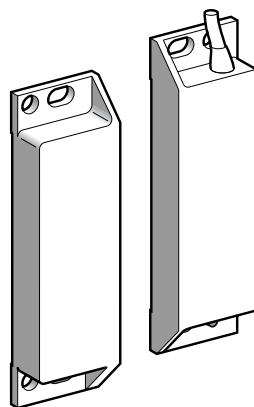

Pages 4 and 5

### XCSDMR

Cylindrical, diameter: 1.18 in (30 mm), length: 1.51 in (38.5 mm)

Pre-cabled connection

Connector on pigtail connection

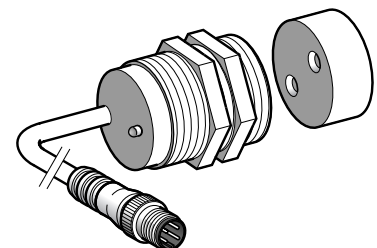
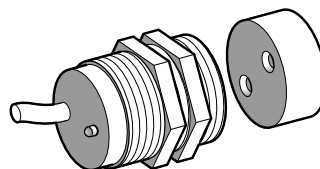

Pages 4 and 5

Environment			
Conformity to standards	Products		IEC/EN 60947-5-1, UL 508, CSA C22 2 n° 14
	Machine assemblies		IEC/EN 60204-1, EN/ISO 12100, EN 1088/ISO 14119 (XCSDM●5●● only)
Product certifications			UL-CSA, BG
Protective treatment			Standard version: "TH"
Ambient air temperature	For operation	°F (°C)	-13...+185 (-25...+85)
	For storage	°F (°C)	-40...+185 (-40...+85)
Vibration resistance			10 gn (10...150 Hz) conforming to IEC 60068-2-6
Shock resistance			30 gn (11 ms) conforming to IEC 60068-2-7
Sensitivity to magnetic fields		mT	≥ 0.3
Electric shock protection			Class II conforming to IEC 60536
Degree of protection	Conforming to IEC 60529		IP 66 and IP 67 for non-contact safety interlock switches with pre-cabled connection IP 67 for non-contact safety interlock switches with connector on pigtail connection
Materials			Thermoplastic case (PBT) PVC cable (ROHS)
Contact block characteristics			
Rated operational characteristics			Ue: ~ 24 V, Ie: 100 mA max.
Rated insulation voltage (Ui)			Ui: ~ 100 V
Rated impulse withstand voltage (U imp)		kV	2.5 conforming to EN/IEC 60947-5-1
Resistance across terminals	Contact with LED	Ω	57
	Contact without LED	Ω	10
Protection (not using safety module)			External cartridge fuse: 500 mA gG (gl)
Connection	XCSDMC		Pre-cabled, 4 x 22 AWG, length: 2, 5 or 10 m depending on model or M8 connector on 5.95 in. (0.15 m) pigtail
	XCSDMP	2 contact model	Pre-cabled, 4 x 22 AWG, length: 2, 5 or 10 m depending on model or M12 connector on 5.95 in. (0.15 m) pigtail
		3 contact model	Pre-cabled, 6 x 22 AWG, length: 2, 5 or 10 m depending on model or M12 connector on 5.95 in. (0.15 m) pigtail
	XCSDMR		Pre-cabled, 4 x 22 AWG, length: 2, 5 or 10 m depending on model or M12 connector on 5.95 in. (0.15 m) pigtail
Contact material			Rhodium
Electrical life			1.2 million operating cycles
Maximum switching voltage		V	~ 100
Switching capacity	Contact with LED	mA	5...100
	Contact without LED	mA	0.1...100
Insulation resistance		MΩ	1000
Maximum breaking capacity	Contact with LED	VA	3
	Contact without LED	VA	10
Maximum switching frequency		Hz	150

# Safety detection solutions

## Non-contact safety interlock switches

### Plastic, pre-cabled

Type	Rectangular		Cylindrical
	Compact 2.01 x 0.63 x 0.28 in (51 x 16 x 7 mm)	Standard 3.46 x 0.98 x 0.51 in (88 x 25 x 13 mm)	Diameter: 1.18 in (30 mm) Length: 1.51 in (38.5 mm)

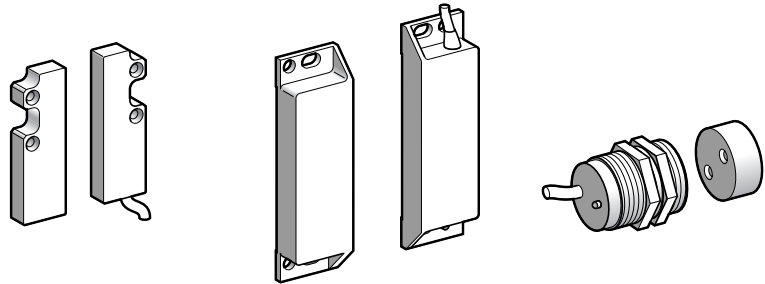

**References of switches (1) must be used in conjunction with safety modules XPS, see pages 10 to 12**  
 Contact states shown are with the magnet positioned in front of the switch

2-pole N.C. + N.O. (N.C. staggered)		<b>XCSDMC5902</b>	<b>XCSDMP5902</b>	<b>XCSDMR5902</b>
2-pole N.O. + N.O. (2) (1 N.O. staggered)		<b>XCSDMC7902</b>	<b>XCSDMP7902</b>	<b>XCSDMR7902</b>
3-pole N.C. + N.C. + N.O. (1 N.C. staggered)		–	<b>XCSDMP5002</b>	–
3-pole N.C. + N.O. + N.O. (2) (1 N.O. staggered)		–	<b>XCSDMP7002</b>	–
2-pole N.C. + N.O. (3) (N.C. staggered) With LED		<b>XCSDMC5912</b>	<b>XCSDMP5912</b>	<b>XCSDMR5912</b>
2-pole N.O. + N.O. (2) (3) (1 N.O. staggered) With LED		<b>XCSDMC7912</b>	<b>XCSDMP7912</b>	<b>XCSDMR7912</b>
3-pole N.C. + N.C. + N.O. (3) (1 N.C. staggered) With LED		–	<b>XCSDMP5012</b>	–
3-pole N.C. + N.O. + N.O. (2) (3) (1 N.O. staggered) With LED		–	<b>XCSDMP7012</b>	–
Weight oz (kg)		3.563 (0.101)	6.349 (0.180)	5.150 (0.146)

- (1) Magnetic switch + coded magnet (XCSCZC●●●●).  
 Switch pre-cabled with 6.6 ft. (2m) long cable. For other cable lengths, replace the last number of the reference (2) by 5 for a 16.4 ft. (5 m) long cable or by 10 for a 32.8 ft. (10 m) long cable.  
 Example: rectangular, compact switch with N.C. + N.O. contacts and 10 m cable becomes **XCSDMC59010**.
- (2) Only to be wired in conjunction with an XPSAF module (see page 11).
- (3) The green LED is lit when the coded magnet is positioned in front of the switch (guard closed).
- N.O. contact PK-GY is to be used as an indicator of the device state, typically to a PLC. It is not to be used for the safety function.

**Complementary characteristics not shown under General characteristics (catalog 9007CT0901 page 6)**

Operating zone	Sao: 0.20 in (5 mm) Sar: 0.59 in. (15 mm)	Sao: 0.31 in. (8 mm) Sar: 0.79 in. (20 mm)	Sao: 0.31 in. (8 mm) 0.79 in. (20 mm)
Approach directions	3 directions	3 directions	1 direction

**Accessories (page 6)**

Characteristics: Page 3	References: Page 4	Accessories: Page 6	Dimensions: Page 8	Wiring Diagrams: Page 10
----------------------------	-----------------------	------------------------	-----------------------	-----------------------------

# Safety detection solutions

## Non-contact safety interlock switches

### Plastic, connector on pigtail

Type	Rectangular		Cylindrical
	Compact	Standard	Diameter: 1.18 in (30 mm) Length: 1.51 in (38.5 mm)
	2.01 x 0.63 x 0.28 in (51 x 16 x 7 mm)	3.46 x 0.98 x 0.51 in (88 x 25 x 13 mm)	
	M8 connector	M12 connector	M12 connector

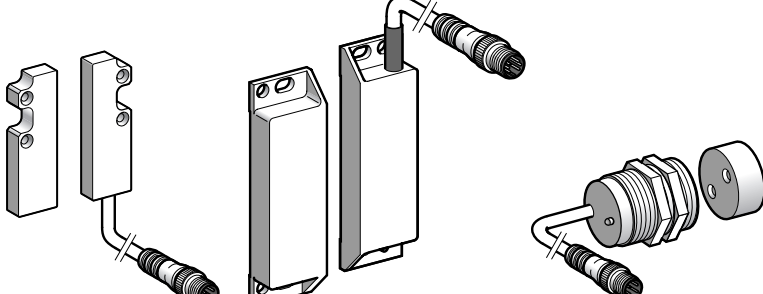

**References of switches (1) must be used in conjunction with safety modules XPS, see pages 10 to 13**  
**Contact states shown are with the magnet positioned in front of the switch**

2-pole N.C. + N.O. (N.C. staggered)		XCSDMC590L01M8	XCSDMP590L01M12	XCSDMR590L01M12
2-pole N.O. + N.O. (2) (1 N.O. staggered)		XCSDMC790L01M8	XCSDMP790L01M12	XCSDMR790L01M12
3-pole N.C. + N.C. + N.O. (1 N.C. staggered)		-	XCSDMP500L01M12	-
3-pole N.C. + N.O. + N.O. (2) (1 N.O. staggered)		-	XCSDMP700L01M12	-
2-pole N.C. + N.O. (3) (N.C. staggered) With LED		XCSDMC591L01M8	XCSDMP591L01M12	XCSDMR591L01M12
2-pole N.O. + N.O. (2) (3) (1 N.O. staggered) With LED		XCSDMC791L01M8	XCSDMP791L01M12	XCSDMR791L01M12
3-pole N.C. + N.C. + N.O. (3) (1 N.C. staggered) With LED		-	XCSDMP501L01M12	-
3-pole N.C. + N.O. + N.O. (2) (3) (1 N.O. staggered) With LED		-	XCSDMP701L01M12	-
Weight oz (kg)		3.563 (0.101)	6.349 (0.180)	5.150 (0.146)

(1) Magnetic switch + coded magnet (XC SZC●●●●).  
 (2) Only to be wired in conjunction with an XPSAF module (see page 9).  
 (3) The green LED is lit when the coded magnet is positioned in front of the switch (guard closed).  
 N.O. contact PK-GY is to be used as an indicator of the device state, typically to a PLC. It is not to be used for the safety function.

**Complementary characteristics not shown under General characteristics (catalog 9007CT0901 page 6)**

Operating zone	Sao: 0.20 in (5 mm) Sar: 0.59 in. (15 mm)	Sao: 0.31 in. (8 mm) Sar: 0.79 in. (20 mm)	Sao: 0.31 in. (8 mm) Sar: 0.79 in. (20 mm)
Approach directions	3 directions	3 directions	1 direction

**Accessories (page 6)**

**Accessories**

Accessories for non-contact safety interlock switches	XCSDMC●●●2 XCSDMC●●●L	XCSDMP●●●2 XCSDMP●●●L	XCSDMR●●●2 XCSDMR●●●L
Mounting clamp	–		<b>XSZ B130</b>
Weight oz (kg)	–		2.822 (0.080)
Additional coded magnet	<b>XCSZC1</b>	<b>XCSZP1</b>	<b>XCSZR1</b>
Weight oz (kg)	0.317 (0.009)	1.764 (0.050)	0.635 (0.018)
Non-magnetic shims	<b>XCSZCC</b> (lot of 2)	<b>XCSZCP</b> (lot of 2)	<b>XCSZCR</b>
Weight oz (kg)	0.282 (0.008)	0.423 (0.012)	0.071 (0.002)

**Pre-wired female connectors for connector version switches**  
**Pre-wired connector characteristics**

Pre-wired connector type	XZCP0941L●, XZCP1041L●	XZCP29P11L●	XZCP1141L●, XZCP1241L●
Type of connection	Screw threaded (metal clamping ring)	Screw threaded (metal clamping ring)	Screw threaded (metal clamping ring)
Number of conductors/pins	4	8	4
Degree of protection	IP 67 (with clamping ring correctly tightened)		
Ambient air temperature	Static: -31...+194 °F (-35...+90 °C) Dynamic: +23...+194 °F (-5...+90 °C)	-31...+194 °F (-35...+90 °C) +23...+194 °F (-5...+90 °C)	-31...+194 °F (-35...+90 °C) +23...+194 °F (-5...+90 °C)
Cabling	Ø 0.205" (5.2 mm) cable, wire c.s.a.: 4 x 22 AWG (0.34 mm <sup>2</sup> )	Ø 0.205" (5.2 mm) cable, wire c.s.a.: 8 x 24 AWG (0.25 mm <sup>2</sup> )	Ø 0.205" (5.2 mm) cable, wire c.s.a.: 4 x 22 AWG (0.34 mm <sup>2</sup> )
LED signalling	–	–	–
Nominal voltage	~ 60 V, --- 75 V	~ 250 V, --- 300 V	~ 250 V, --- 300 V
Nominal current	4 A	2 A	4 A
Insulation resistance	> 10 <sup>9</sup> Ω	> 10 <sup>9</sup> Ω	> 10 <sup>9</sup> Ω
Contact resistance	≤ 5 mΩ	≤ 5 mΩ	≤ 5 mΩ

**References of pre-wired connectors**

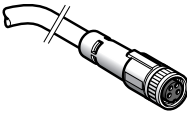
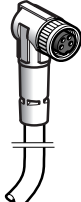
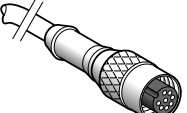
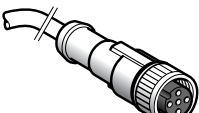
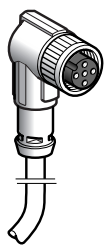
	Type of connector	Number of pins	For use with	Type	Cable length ft. (m)	Reference	Weight oz (kg)	
 XZ CP0941L●	Female, M8	4	XCSDMC●●●L	Straight	6.56 (2)	<b>XZCP0941L2</b>	2.822 (0.080)	
					16.40 (5)	<b>XZCP0941L5</b>	6.349 (0.180)	
					32.81 (10)	<b>XZCP0941L10</b>	12.699 (0.360)	
					Elbowed	6.56 (2)	<b>XZCP1041L2</b>	2.822 (0.080)
						16.40 (5)	<b>XZCP1041L5</b>	6.349 (0.180)
						32.81 (10)	<b>XZCP1041L10</b>	12.699 (0.360)
 XZ CP1041L●	Female, M12	8	XCSDMP●●●L	Straight	6.56 (2)	<b>XZCP29P11L2</b>	3.527 (0.100)	
					16.40 (5)	<b>XZCP29P11L5</b>	10.229 (0.290)	
					32.81 (10)	<b>XZCP29P11L10</b>	16.579 (0.470)	
					Elbowed	6.56 (2)	<b>XZCP1141L2</b>	3.175 (0.090)
						16.40 (5)	<b>XZCP1141L5</b>	6.702 (0.190)
						32.81 (10)	<b>XZCP1141L10</b>	13.051 (0.370)
 XZ CP29P11L●	Female, M12	4	XCSDMR●●●L/ XCSDMP●●●L	Straight	6.56 (2)	<b>XZCP1141L2</b>	3.175 (0.090)	
					16.40 (5)	<b>XZCP1141L5</b>	6.702 (0.190)	
					32.81 (10)	<b>XZCP1141L10</b>	13.051 (0.370)	
					Elbowed	6.56 (2)	<b>XZCP1241L2</b>	3.175 (0.090)
						16.40 (5)	<b>XZCP1241L5</b>	6.702 (0.190)
						32.81 (10)	<b>XZCP1241L10</b>	13.051 (0.370)
 XZ CP1141L●								
								 XZ CP1241L●



### Function diagrams with magnet present (pre-cabled version)

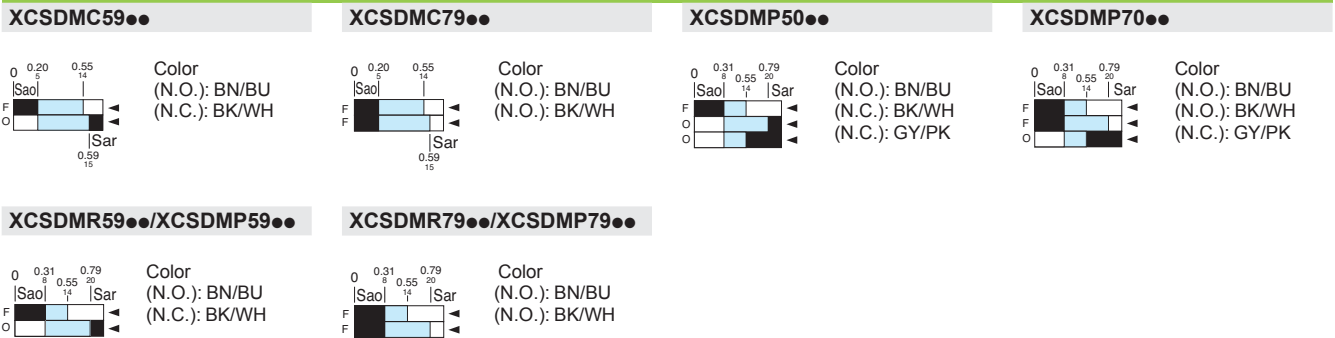

### Function diagrams with magnet present (connector on pigtail version)

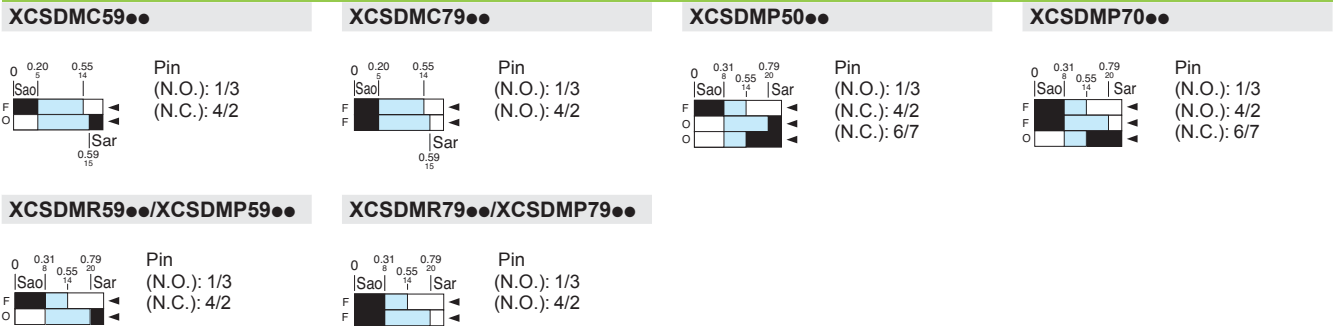

**Sao**: specified operating distance.  
**Sar**: specified tripping distance.  
 Conforming to EN/IEC 60947-5-3.

#### Non-contact safety interlock switches

##### XCSDMC

###### Pre-cabled connection

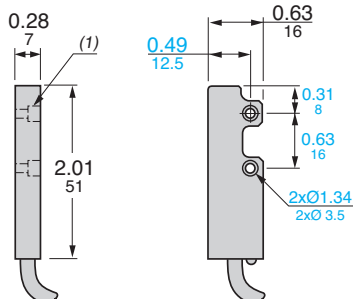

###### Connector on pigtail connection

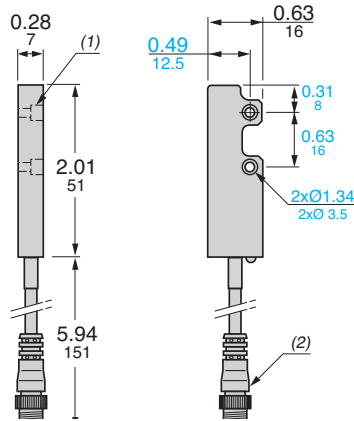

##### Coded magnet for XCSDMC

###### XCSZC1

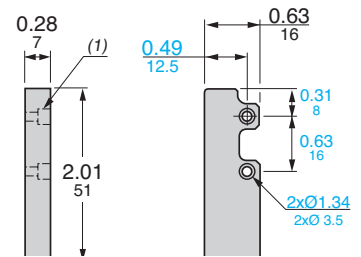

Dual Dimensions: INCHES  
Millimeters

(1) Counterbored: 0.24 x 0.14 in. (Ø 6 x 3.5 mm.)

(1) Counterbored: 0.24 x 0.14 in. (Ø 6 x 3.5 mm.)  
(2) M8 4-pin connector.

(1) Counterbored: 0.24 x 0.14 in. (Ø 6 x 3.5 mm.)

##### XCSDMP

###### Pre-cabled connection

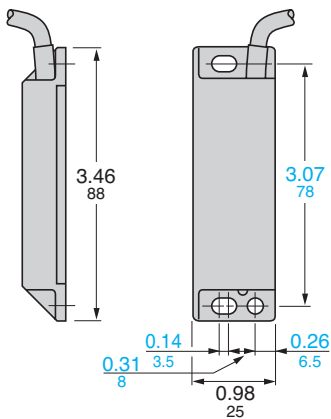

###### Connector on pigtail connection

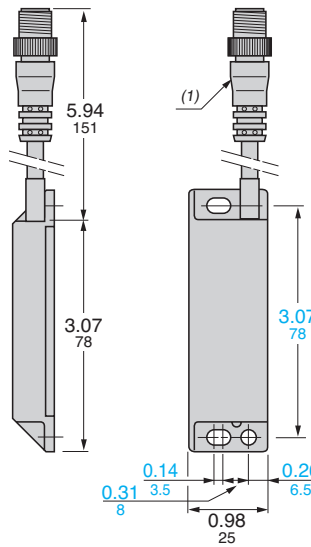

(1) 4 or 6-pin M12 connector.

##### Coded magnet for XCSDMP

###### XCSZP1

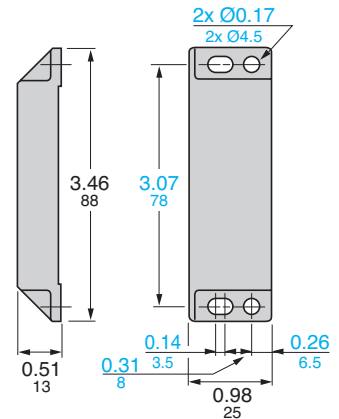

##### XCSDMR

###### Pre-cabled connection

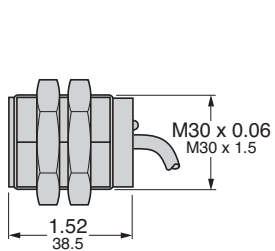

###### Connector on pigtail connection

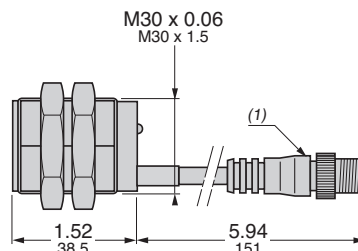

(1) M12 4-pin connector.

##### Coded magnet for XCSDMR

###### XCSZR1

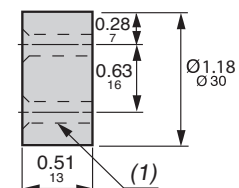

(1) 0.08 x Ø 0.17 (2 x Ø 4.3), countersunk: Ø 7.5 at 45°.

### Accessories

#### Mounting clamp

XSZ B130

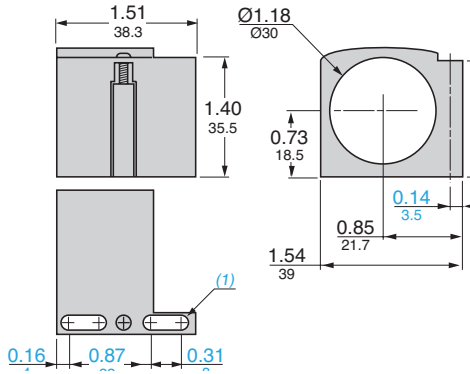

(1) 2 elongated holes  $\varnothing 4 \times 8$ .

#### Non-magnetic shims

XCSZCC

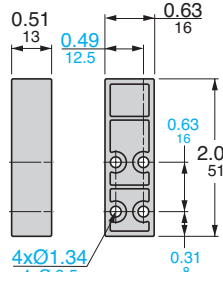

XCSZCP

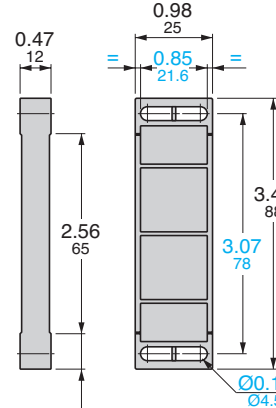

XCSZCR

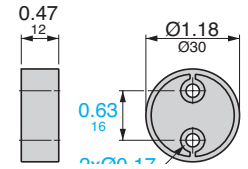

#### Pre-wired female connectors

XZ CP0941L

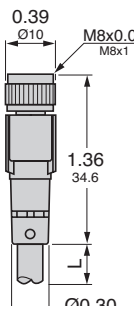

XZ CP1041L

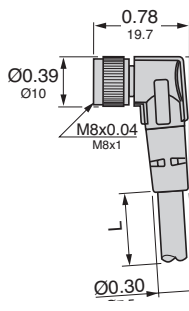

XZ CP1141L

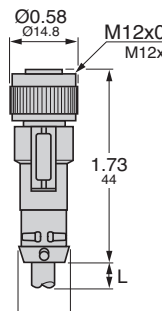

XZ CP1241L

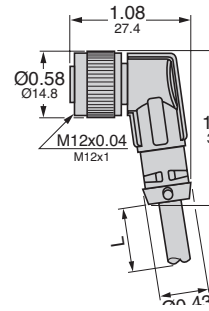

XZ CP29P11L

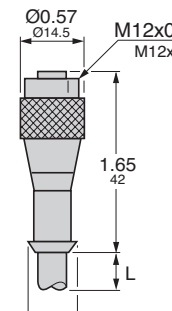

### Wiring diagrams

#### M8 pre-wired female connector

XZ CP0941L

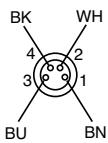

#### M12 pre-wired female connector

XZ CP1141L, XZ CP1241L

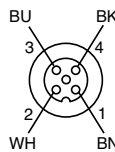

XZ CP29P11L

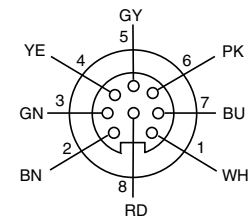

### Mounting

XCSDMC

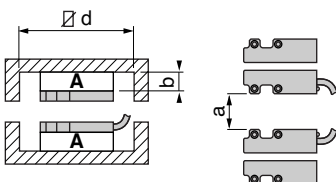

XCSDMP

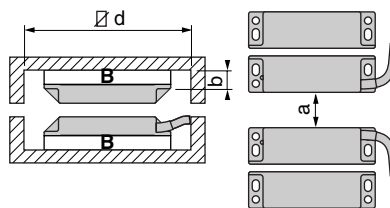

XCSDMR

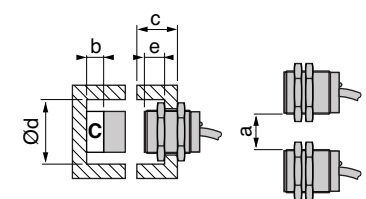

XCS	a	b	c	d	e
DMC	1.57 (40)	13 min.	–	3.19 x 2.17 (81 x 55)	–
DMP	3.94 (100)	10 min.	–	4.65 x 2.17 (118 x 55)	–
DMR	1.57 (40)	12 min.	> 0.39 (10)	$\varnothing 1.77$ (45)	20
		–	> 0.39 (10)	$\varnothing 1.77$ (45)	13
		12 min.	< 0.39 (10)	–	20
		–	< 0.39 (10)	–	17

#### Non-magnetic shims

A	XCSZCC
B	XCSZCP
C	XCSZCR

Dual Dimensions: INCHES  
Millimeters

**XCSDMP5... with XPSDMB**

Wiring to category 4 conforming to EN 954-1/ISO 13849-1. Example with 3-pole N.C. + N.C. + N.O. (1 N.C. staggered) contact.

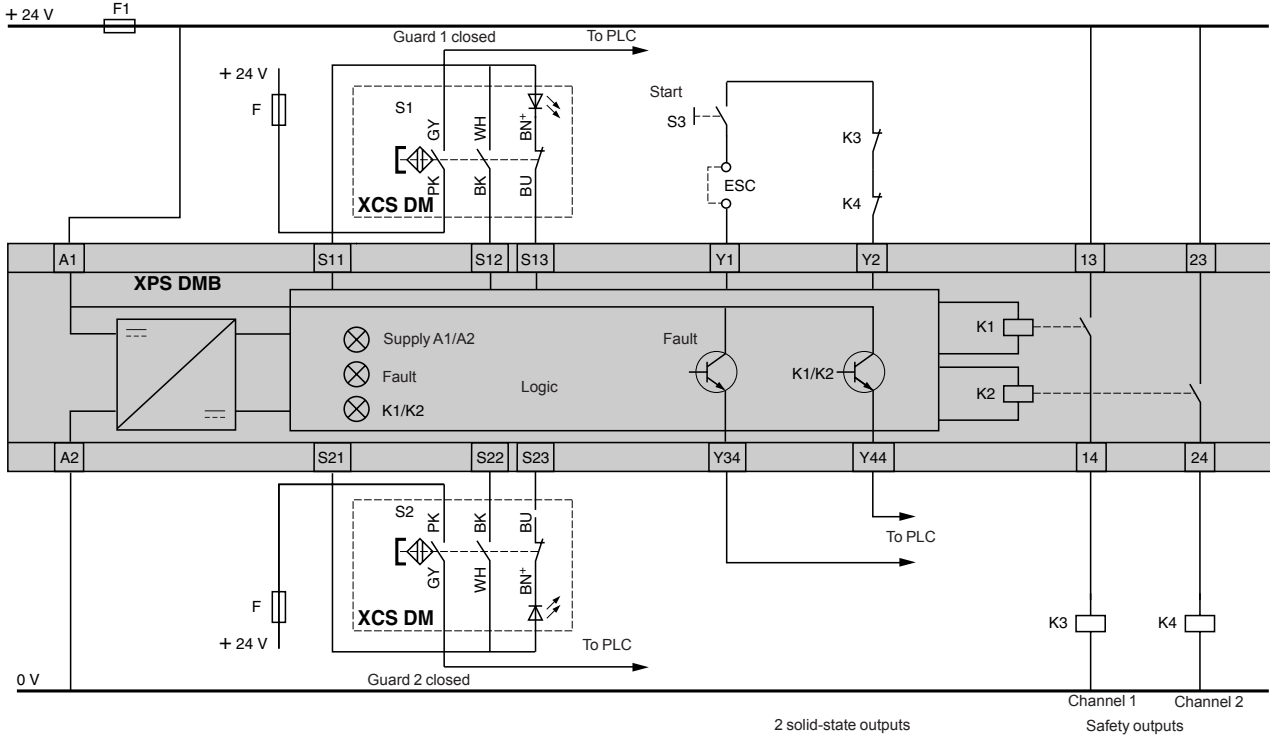

ESC: External start conditions.

- Inputs: S11, S12, S13 or S21, S22, S23
- Unused inputs must be jumpered from S\_1 to S\_3. For example: S21 to S23.
- The order in which the inputs are wired or jumpered will not affect device operation.

**XCSDMC5... , XCSDMP5... , XCSDMR5... with XPSDME**

Wiring to category 4 conforming to EN 954-1/ISO 13849-1. Example with 2-pole N.C. + N.O. (N.C. staggered) contact.

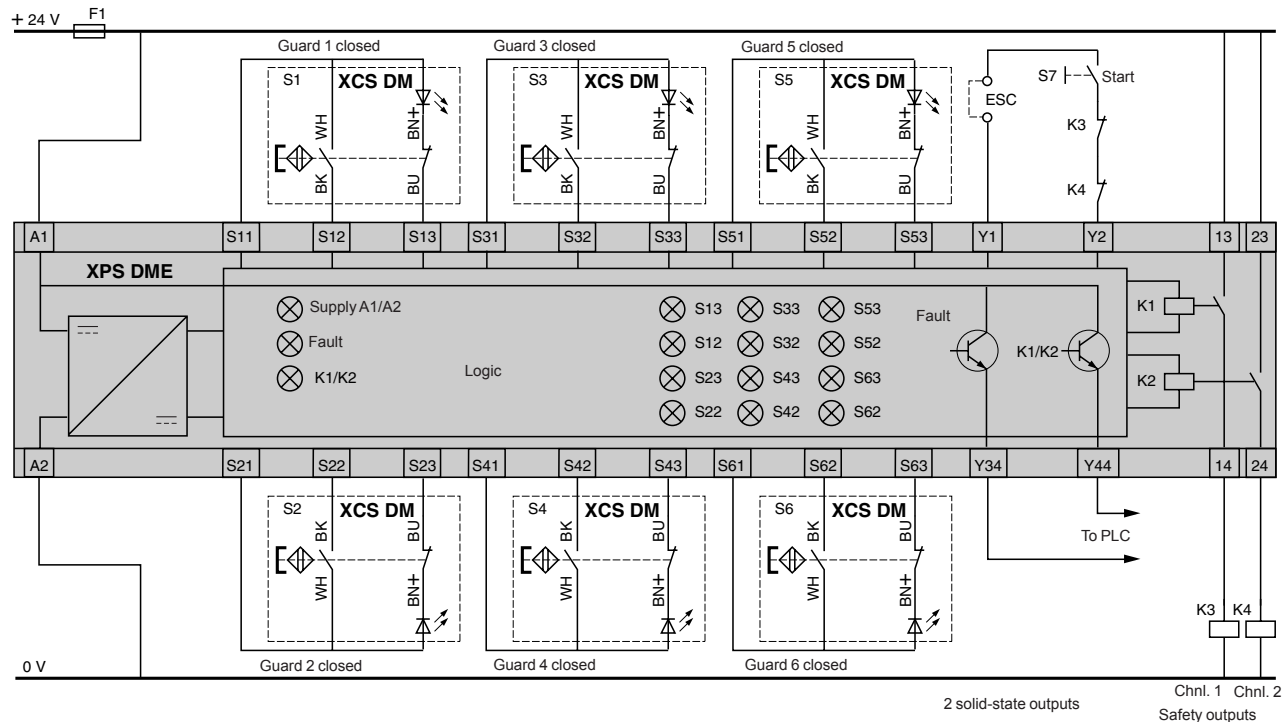

ESC: External start conditions.

- Inputs: S\_1, S\_2, S\_3
- Unused inputs must be jumpered from S\_1 to S\_3. For example if input S61, S62, S63 is not used, then terminals S61 and S63 must be jumpered.
- The order in which the inputs are wired or jumpered will not affect device operation.

References:  
pages 4 and 5

Connection of up to 3 non-contact safety interlock switches, with an LED on one input, with XPSDM● (1)

Wiring to category 3 conforming to EN 954-1/ISO 13849-1

Example with 2-pole N.C. + N.O. contact

Example with 3-pole N.C. + N.C. + N.O. contact

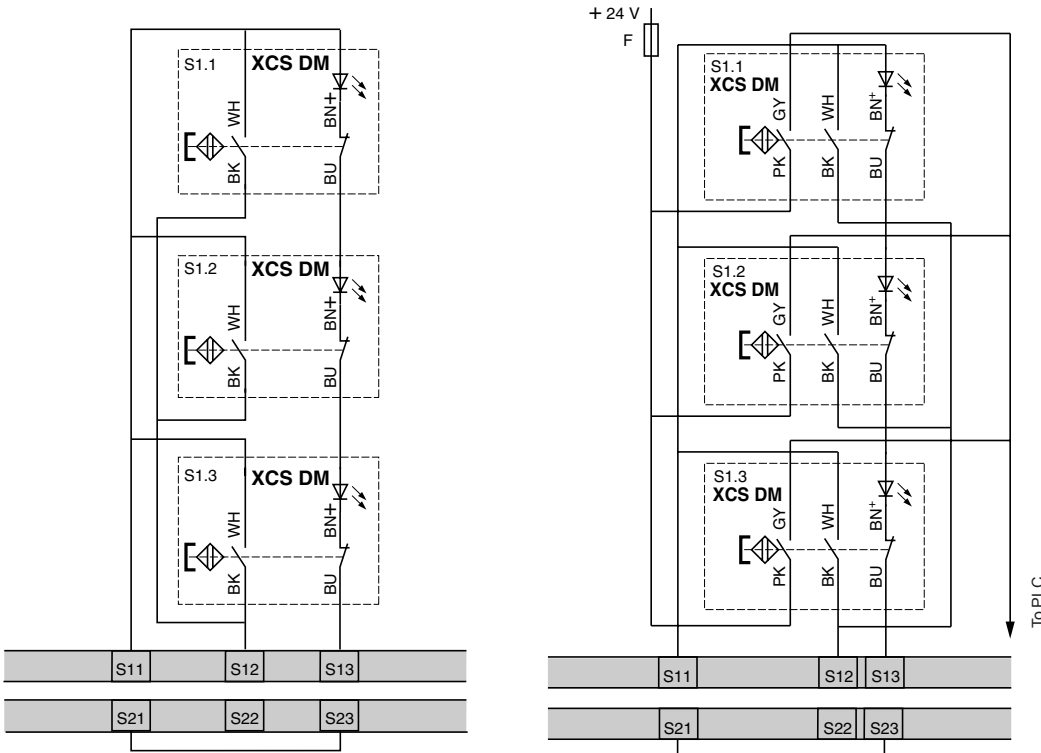

(1) Input: S11, S12, S13 or S21, S22, S23.

XCSDM●7●●● with XPSAF

Wiring to category 4 conforming to EN 954-1/ISO 13849-1. Example with 2-pole N.C. + N.C. contact (not conforming to standard EN 1088/ISO 14119)

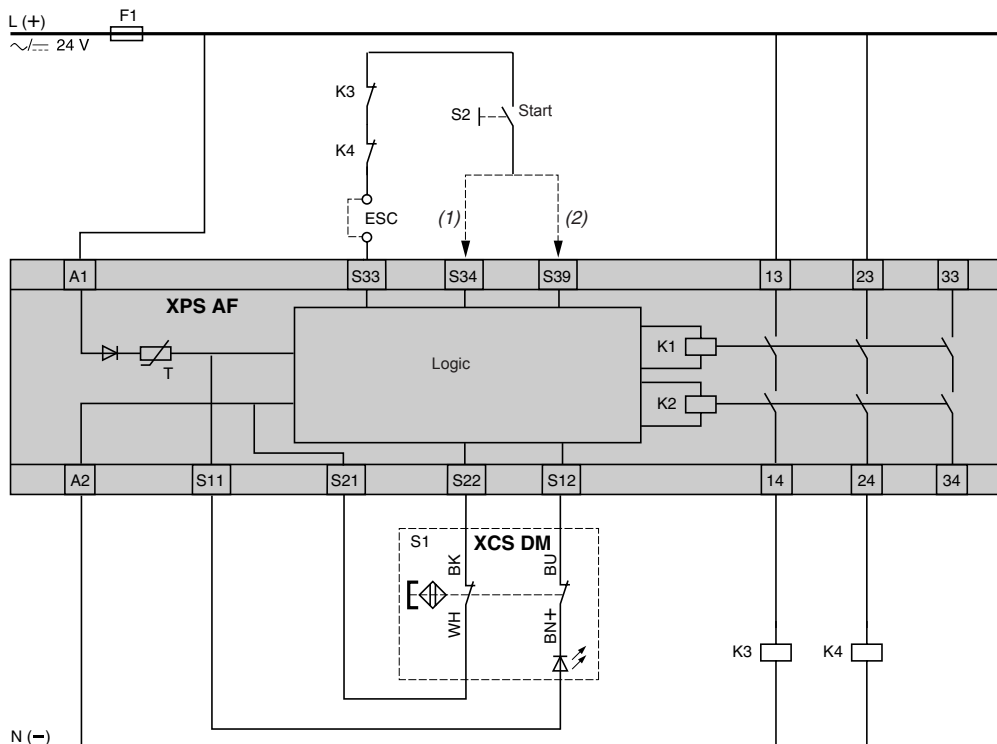

(1) With start button monitoring.  
 (2) Without start button monitoring.  
 ESC: External start conditions.

# Safety detection solutions

## Non-contact safety interlock switches

### Plastic, connector on pigtail

#### XCSDMP5... with XPSDMB

Wiring to category 4 conforming to EN 954-1/ISO 13849-1. Example with 3-pole N.C. + N.C. + N.O. (1 N.C. staggered) contact.

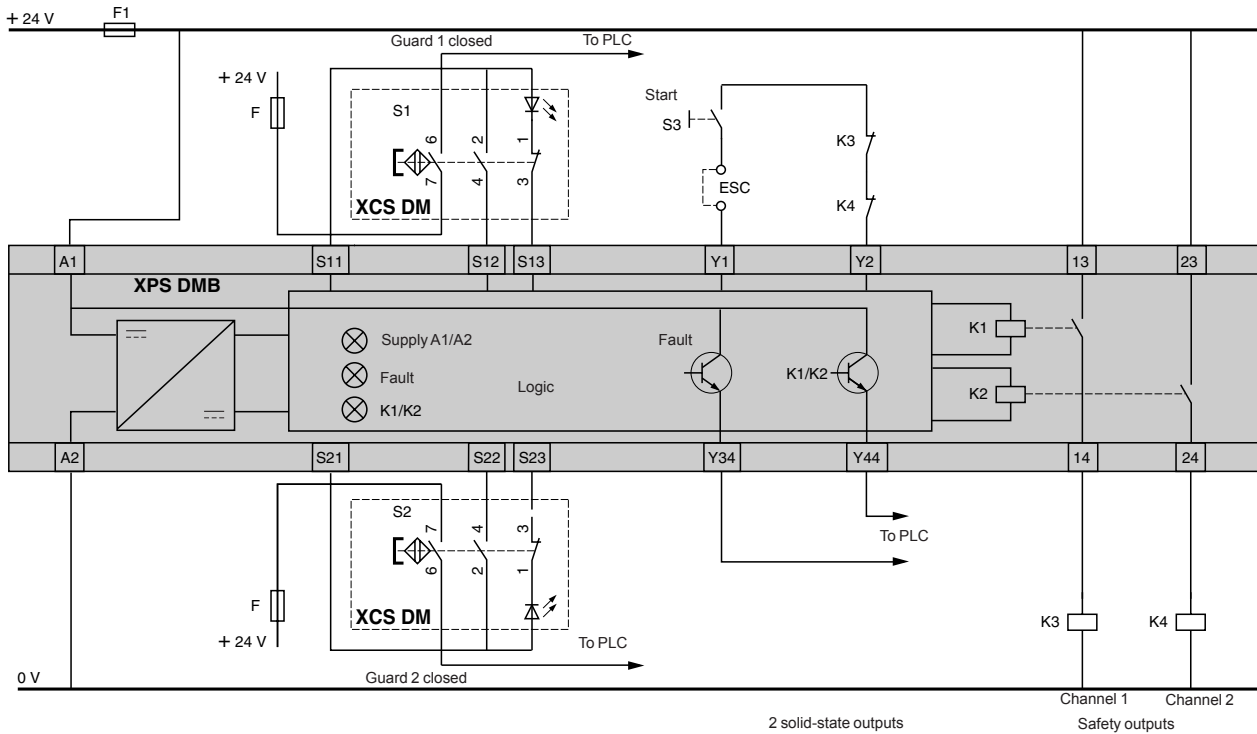

ESC: External start conditions.

- Inputs: S11, S12, S13 or S21, S22, S23
- Unused inputs must be jumpered from S\_1 to S\_3. For example: S21 to S23.
- The order in which the inputs are wired or jumpered will not affect device operation.

#### XCSDMC5... , XCSDMP5... , XCSDMR5... with XPSDME

Wiring to category 4 conforming to EN 954-1/ISO 13849-1. Example with 2-pole N.C. + N.O. (N.C. staggered) contact.

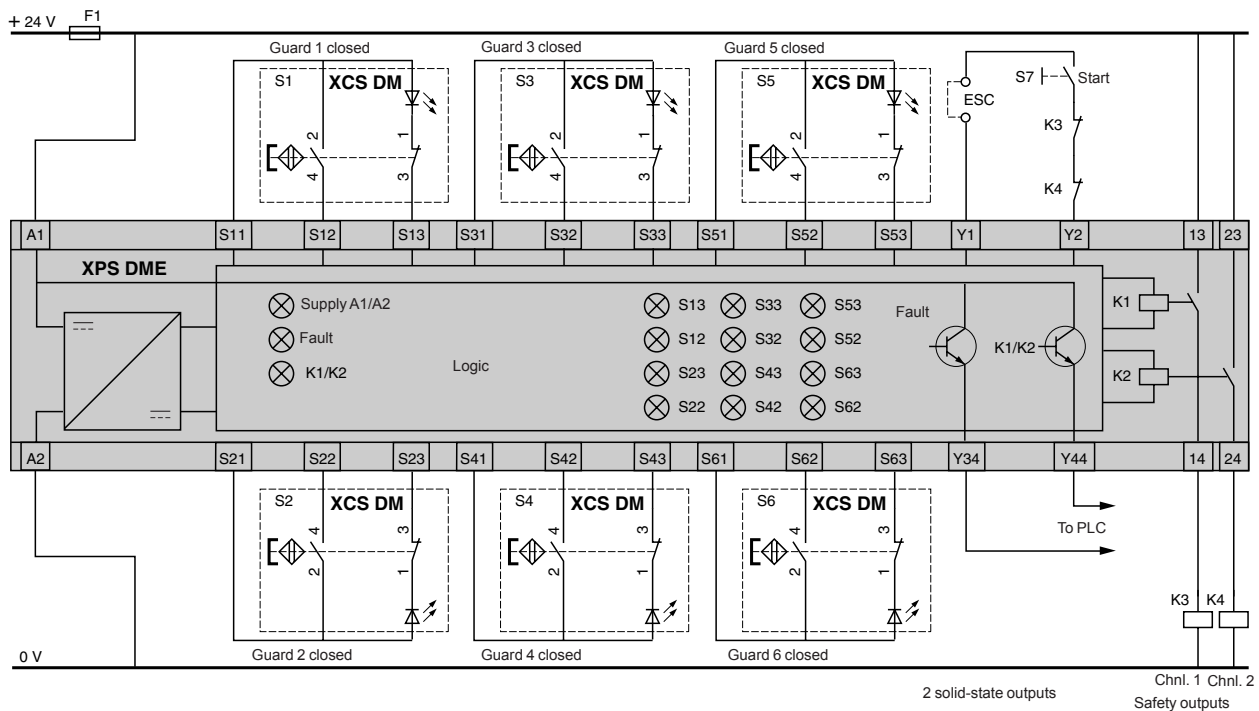

ESC: External start conditions.

- Inputs: S\_1, S\_2, S\_3
- Unused inputs must be jumpered from S\_1 to S\_3. For example if input S61, S62, S63 is not used, then terminals S61 and S63 must be jumpered.
- The order in which the inputs are wired or jumpered will not affect device operation.

References:  
pages 4 and 5

# Safety detection solutions

## Non-contact safety interlock switches

Plastic, connector on pigtail

Connection of up to 3 non-contact safety interlock switches, with an LED on one input, with XPSDM● (1)

Wiring to category 3 conforming to EN 954-1/ISO 13849-1

Example with 2-pole N.C. + N.O. contact

Example with 3-pole N.C. + N.C. + N.O. contact

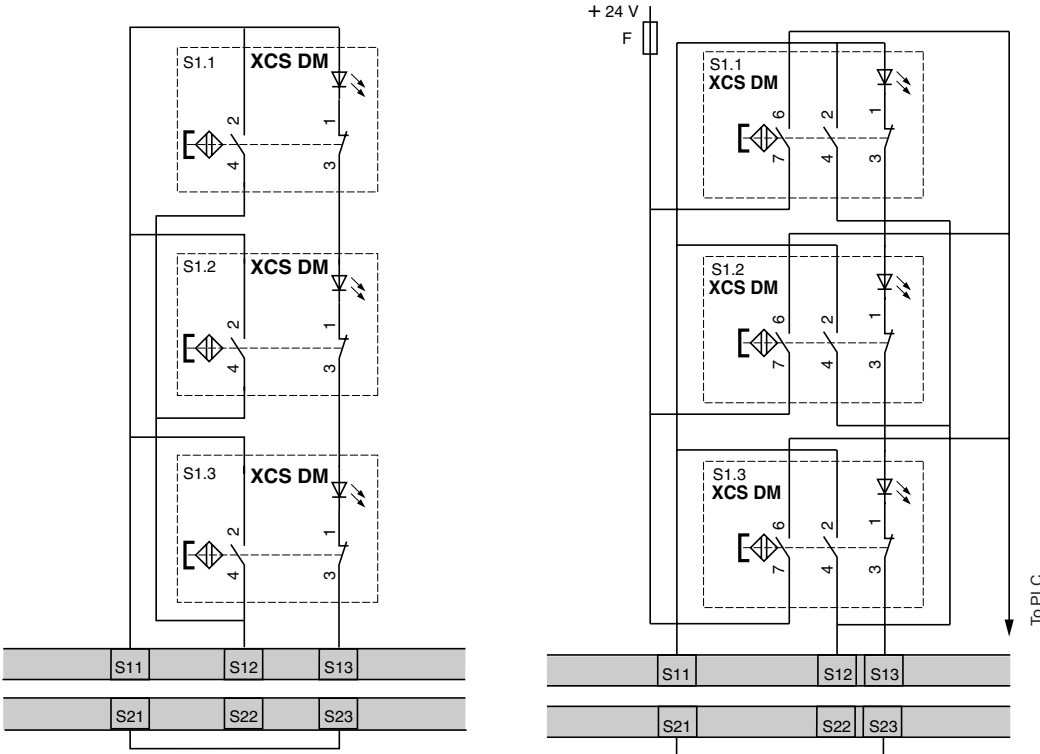

(1) Input: S11, S12, S13 or S21, S22, S23.

### XCSDM●7●●● with XPSAF

Wiring to category 4 conforming to EN 954-1/ISO 13849-1. Example with 2-pole N.C. + N.C. contact (not conforming to standard EN 1088/ISO 14119)

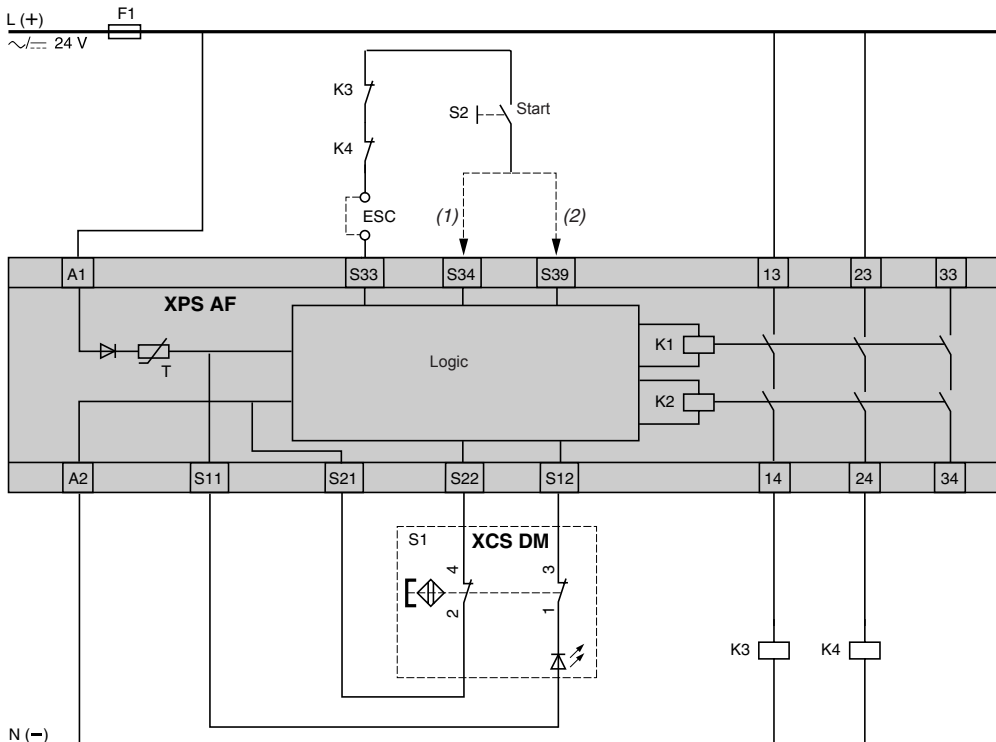

(1) With start button monitoring.  
 (2) Without start button monitoring.  
 ESC: External start conditions.

**Non-Contact safety interlock switches  
Pre-cabled connection**

SIL 2 and 3/Categories 3 and 4  
XCSDM3791●●/XCSDM4801●●

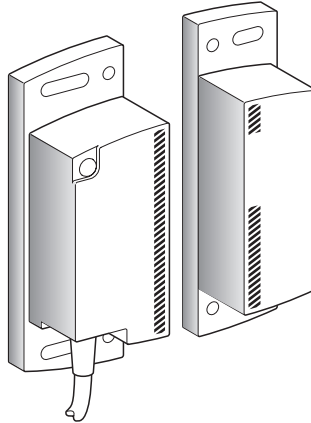

page 6

**Non-Contact safety interlock switches  
M12 connector connection**

SIL 2 and 3/Categories 3 and 4  
XCSDM3791M12/ XCSDM4801M12

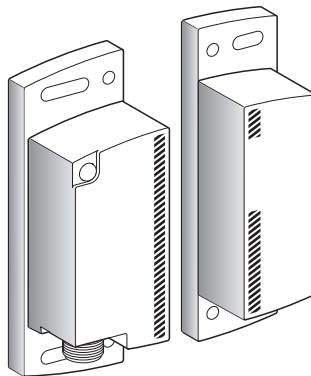

page 18



Non-Contact safety interlock type		SIL2/Category 3 XCSDM3	SIL3/Category 4 XCSDM4
<b>Environment</b>			
<b>Conformity to standards</b>		IEC 61508, EN/IEC 62061( SIL2 and SIL3), EN 13849-1 (Category 3 and Category 4), EN 1088/ISO 14119, EN/IEC 60947-5-1; EN/IEC 60947-5-2 ; EN/IEC 60947-5-3	
<b>Product certifications</b>		CE, UL, CSA, TÜV	
<b>Ambient air temperature</b>	For operation	<b>°F (°C)</b>	-13...+158 (-25...+70)
	For storage	<b>°F (°C)</b>	+ 40 ...+ 185 (-40...+85)
<b>Vibration resistance</b>	Conforming to IEC 60068-2-6		10 gn (10...500 Hz)
<b>Shock resistance</b>	Conforming to IEC 60068-2-7		30 gn, 11 ms
<b>Sensitivity to magnetic fields</b>		<b>mT</b>	≤ 0,5
<b>Electric shock protection</b>	Conforming to IEC 61140		Class III
<b>Degree of protection</b>	Conforming to IEC 60529		Pre-cabled version: IP 66, IP 67 Connector version: IP 67
	Conforming to DIN 40050		Pre-cabled version: IP 69K
<b>Materials</b>		Thermoplastic case (PBT); PVC cable	
<b>Characteristics</b>			
<b>Rated operational characteristics</b>		Ub : ∓ 24 V + 10% - 20%	
<b>Rated insulation voltage (Ui)</b>		Ui : ∓ 36V	
<b>Rated impulse withstand voltage (U imp)</b>	Conforming to EN 60947-5-1	<b>kV</b>	2,5
<b>Integrated output protection</b>		Overload and short-circuit protection	
<b>Connection</b>	Conforming to IEC 60947-5-2-A3 and IEC 61076		Pre-cabled, 6 x 22 AWG (0.25 mm <sup>2</sup> ), length: 6.6, 16.4 or 32.8 ft. (2, 5, or 10 m) depending on model or M12 connector (A coding)   Pre-cabled, 8 x 22 AWG (0.25 mm <sup>2</sup> ), length: 6.6, 16.4 or 32.8 ft. (2, 5, or 10 m) depending on model or M12 connector (A coding)
<b>Cable diameter</b>		<b>in. (mm)</b>	0.24 (6.1 +/- 0.3)
<b>Cable resistance</b>		<b>mΩ/m</b>	90
<b>Safety outputs (OSSD) (Output Signal Switching Devices)</b>			2 PNP type (NO) solid-state outputs, 1.5 A (2 A up to 140 °F (60°C)), ∓ 24 V (short-circuit protected)
<b>Alarm output</b>			1 solid-state output, 0.5 A, ∓ 24 V, PNP
<b>Signalling</b>			LED (green/red/orange)
<b>Maximum switching frequency</b>		<b>Hz</b>	3
<b>Activation delay</b>		<b>ms</b>	100
<b>Discordance time</b>		<b>s</b>	2
<b>HFT (Hardware Fault Tolerance)</b>			1 Test interval: 12 months
<b>Tightening torque</b>		<b>lb-ft (Nm)</b>	1.327 (1.8) maximum
<b>Maximum series mounting</b>			32 maximum with 6.6 ft. (2 m) long cable   -
<b>Functions</b>			
<b>Functions</b>		- LED status signalling	- Auto/Manual start via "Start" input - Monitoring of external switching devices (EDM: External Devices Monitoring) - Display of operating modes (LED) - Monitoring of the function (open or closed) as well as the response time of the power components.

**Type** Non-Contact safety interlock switches with dedicated transmitter  
**Pre-cabled connection**

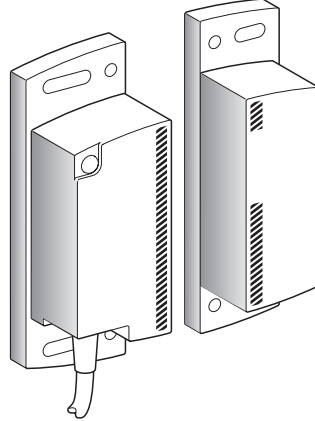

**References**

Description	Type of connection	SIL2/Category 3	SIL3/Category 4	Weight oz (kg)
Magnetic system with dedicated transmitter (1)	Pre-cabled, L = 6.6 ft (2 m)	<b>XCSDM379102</b>	<b>XCSDM480102</b>	11.288 (0.320)
	Pre-cabled, L = 16.4 ft. (5 m)	<b>XCSDM379105</b>	<b>XCSDM480105</b>	16.932 (0.480)
	Pre-cabled, L = 32.8 ft. (10 m)	<b>XCSDM379110</b>	<b>XCSDM480110</b>	26.279 (0,745)

(1) Self-contained system not requiring use of safety module or non-magnetic shim.

**Detection characteristics**

Assured operating distance	Sao : 10 mm
Assured tripping distance	Sar : 20 mm
Approach directions	9
Approach speed	0,01 m/s mini

**Output status (pre-cabled connection)**

Output states shown are with the dedicated transmitter positioned in front of the receiver.

**XCSDM3791●●**

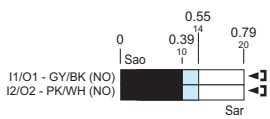

**XCSDM4801●●**

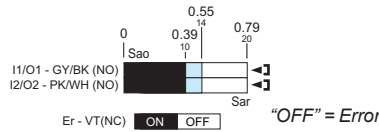

- Output closed
- Output open
- Transitional state

**Sao** : Specified operating distance.  
**Sar** : Specified tripping distance.  
Conforming to EN/IEC 60947-5-3

**Approach directions**

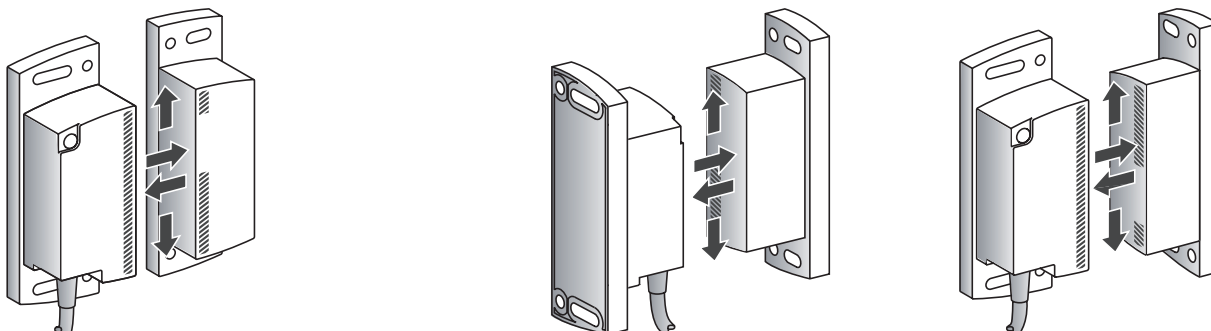

<b>Type</b>	<b>Non-contact safety interlock with dedicated transmitter</b>
	<b>M12 connector connection</b>

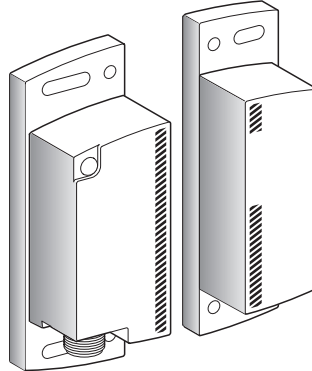

References				
Description	Type of connection	SIL2/Category 3	SIL3/Category 4	Weight oz (kg)
Non-Contact safety interlock switches with dedicated transmitter (1)	M12 connector	XCSDM3791M12	XCSDM4801M12	7.584 (0.215)

1) Self-contained system not requiring use of safety module or non-magnetic shim.

Detection characteristics	
Assured operating distance	Sao : 0.39 in. (10 mm)
Assured tripping distance	Sar : 0.79 in. (20 mm)
Approach directions	9
Approach speed	0.03 ft./s (0.01 m/s) mini

### Output status (pre-cabled connection)

Output states shown are with the dedicated transmitter positioned in front of the receiver.

#### XCSDM3791M12

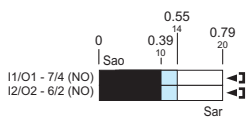

#### XCSDM4801M12

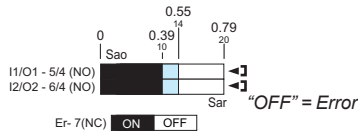

- Output closed
- Output open
- Transitional state

**Sao** : Specified operating distance.  
**Sar** : Specified tripping distance.  
 Conforming to EN/IEC 60947-5-3

Accessories			
Description	For use with	Reference	Weight oz (kg)
Replacement dedicated transmitter	XCSDM3/4●●●02/05/10 XCSDM3/4●●●M12	<b>XCSDMT</b>	3.527 (0.100)
Arc suppressor (pair)	XCSDM3/4●●●02/05/10 XCSDM3/4●●●M12	<b>XUSLZ500</b>	0.705 (0.020)

**Pre-wired female connectors for connector version Non-contact safety interlock switches**

Pre-wired connector characteristics

Pre-wired connector type		XZ CP29P12L●	
Type of connection		Screw threaded (metal clamping ring)	
Number of contacts		8	
Degree of protection		IP 67 (with clamping ring correctly tightened)	
Ambient air temperature	Operation	°F (°C)	- 13 ...+ 158 (- 25 ...+ 70)
	Storage	°F (°C)	- 40 ...+ 185 (- 40 ...+ 85)
Cabling	Conforming to IEC 60947-5-2	Ø 6.1 mm PUR cable, wire c.s.a.: 8 x 22 AWG (0.25 mm <sup>2</sup> )	
LED signalling		-	
Nominal current		A	2
Insulation resistance		Ω	> 10 <sup>9</sup>
Contact resistance		mΩ	≤ 5

References of pre-wired connectors

Type of connector	No. of contacts	For use with	Type	Cable length ft. (m)	Reference	Weight oz (kg)
Female, M12 (Coding A)	8	XCSDM3/4●●●02	Straight	6.6 (2)	<b>XZCP29P12L2</b>	3.527 (0.100)
		XCSDM3/4●●●05		16.4 (5)	<b>XZCP29P12L5</b>	10.229 (0.290)
		XCSDM3/4●●●10		32.8 (10)	<b>XZCP29P12L10</b>	16.579 (0.470)

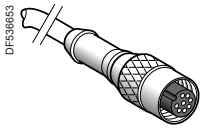

XZ CP29P12L●

**Non-contact safety interlock switches**

Pre-cabled connection  
XCSDM3/4●●●02/05/10

M12 connector (Coding A) connection  
XCSDM3/4●●●M12

**Accessory**

Replacement dedicated transmitter  
XCSDMT

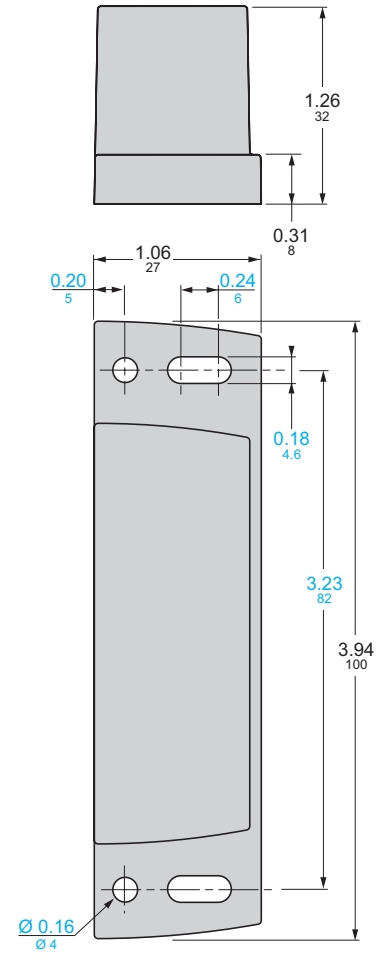
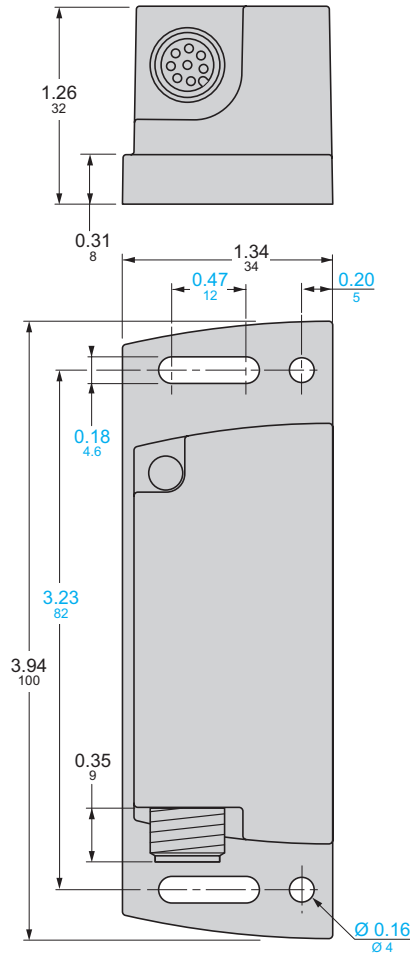
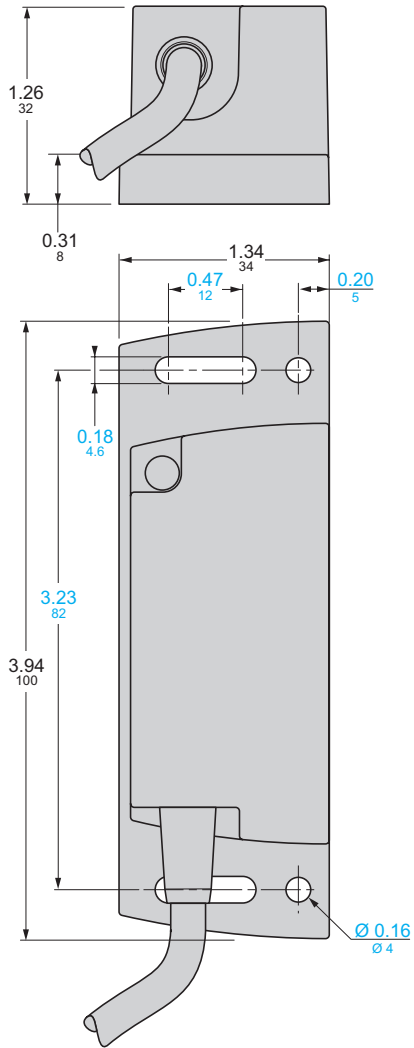

Dual Dimensions: INCHES  
Millimeters

**Pre-wired female connectors**

XZ CP29P12L●

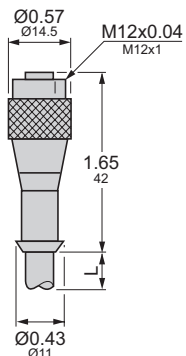

Wiring diagram

M12 pre-wired female connector

XZ CP29P12L●

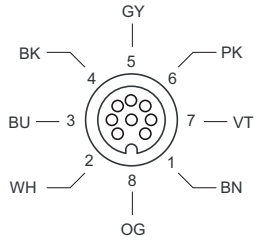

Mounting

XCSDM3/DM4

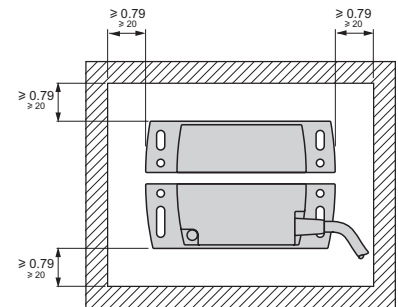
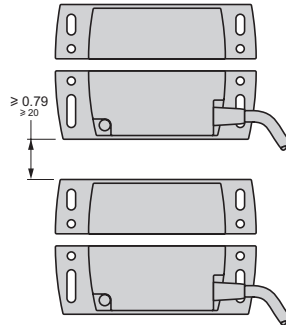
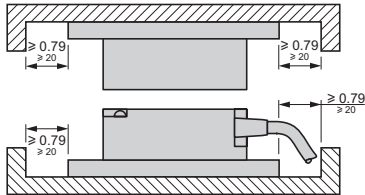

Dual Dimensions: INCHES  
Millimeters

Wiring diagrams

Category 3 (this Category 3 wiring can attain SIL2)

Pre-cabled connection

XCSDM3791●●

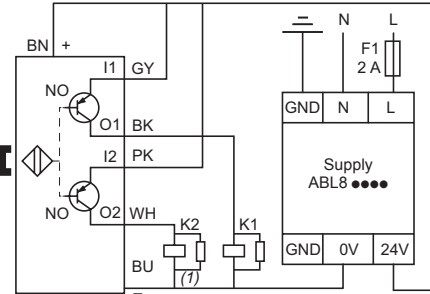

M12 connector (A coding) connection

XCSDM3791M12

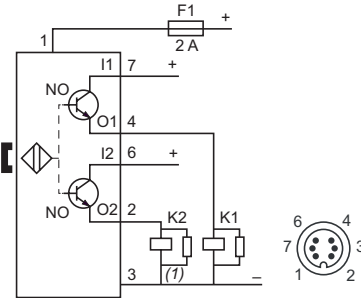

SIL3/Category 4

Pre-cabled connection

XCSDM4801●●

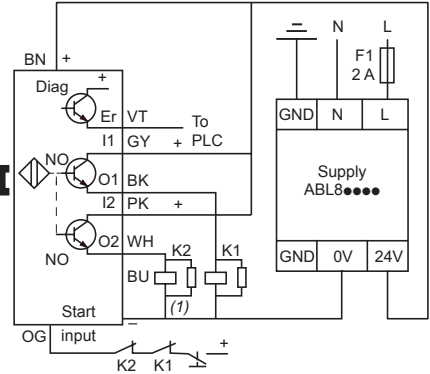

M12 connector (A coding) connection

XCSDM4801M12

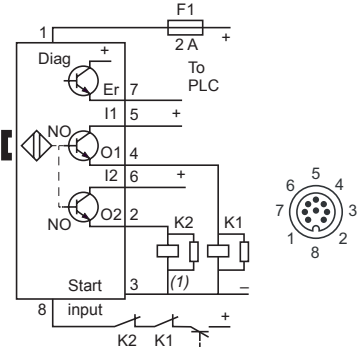

Series mounting non-contact safety interlock switches (2)

XCSDM3791●●

Wiring to SIL3/Category 4 with safety relay module

Example: XCSDM3●●●● + XPSAFL5130

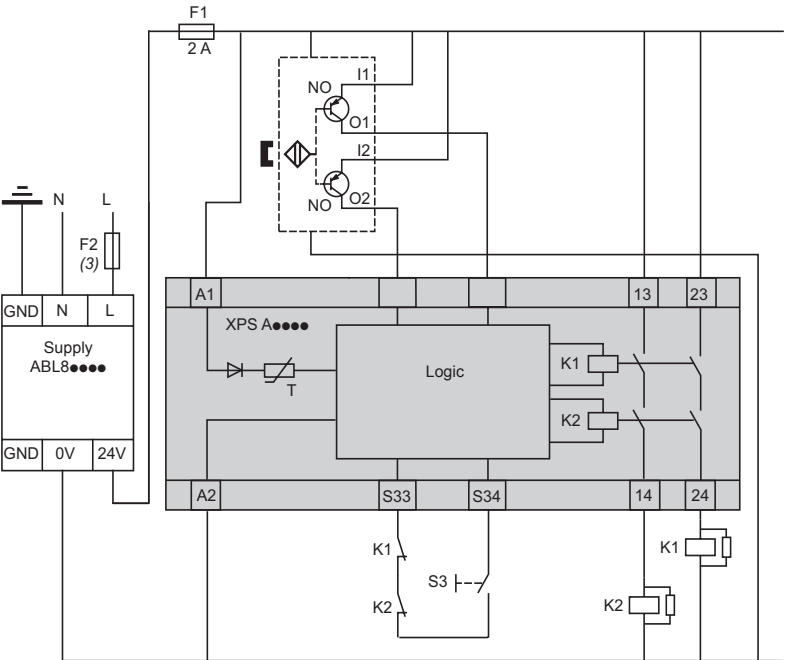
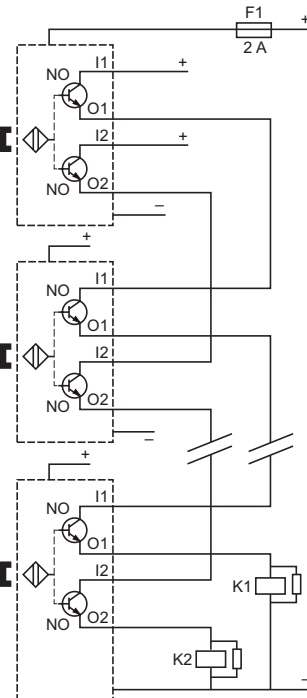

(1) Mechanically linked contacts

(2) Maximum series mounting: 32 maximum with 6.6 ft. (2 m) long cable.

(3) 2A maximum

**Schneider Electric**

[www.schneider-electric.com](http://www.schneider-electric.com)

North American  
Operating Division  
1415 South Roselle Road  
Palatine, IL 60067  
USA

Due to evolution of standards and equipment, the characteristics indicated in texts and images of this document do not constitute a commitment on our part without confirmation.

Design: Schneider Electric  
Photos: Schneider Electric

TEL: 847-397-2600

© 2009 Schneider Electric. All rights reserved.

ART. 960260

2009

9007CT0903