

Electric Slide Tables



LES/LESH Series

Step Motor (Servo/24 VDC)

Servo Motor (24 VDC)

- Reduced cycle time
- Positioning repeatability: ± 0.05 mm
- Max. pushing force: 180 N
- Max. acceleration/deceleration: 5000 mm/s²
- Max. speed: 400 mm/s

Compact Type LES Series

Size: 8, 16, 25 ▶ Page 314



Compared with the LESH, Workpiece mounting surface height: Reduced by up to 12%

40.3 mm

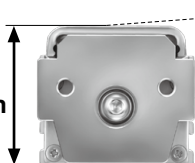

Compact type
LES16D

46 mm

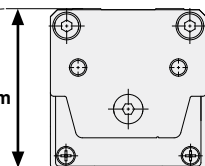

LESH16D

Basic type/R type



Symmetrical type/L type



In-line motor type/D type



High Rigidity Type LESH Series

Size: 8, 16, 25 ▶ Page 340

High rigidity

Deflection: 0.016 mm*

* LESH16-50 Load: 25 N

Basic type/R type

LESH□R Series



Symmetrical type/L type

LESH□L Series



In-line motor type/D type

LESH□D Series



Step Motor (Servo/24 VDC)

Servo Motor (24 VDC)

Controller/Driver

▶ Page 547

▶ Step data input type

LECP6/LECA6 Series

- 64 points positioning
- Input using controller setting kit or teaching box



▶ CC-Link direct input type

LECPM/J Series*

▶ EtherCAT®/EtherNet/IP™/PROFINET/DeviceNet™/IO-Link direct input type

JXCE1/91/P1/D1/L1 Series

* Not applicable to CE.



▶ Programless type

LECP1 Series

- 14 points positioning
- Control panel setting



▶ Pulse input type

LECPA Series



Electric Slide Tables

Compact Type LES Series

Vertical work load

Increased by up to **50%***

* By reducing weight of the moving parts
* Compared with the LESH16

Model	Vertical work load [kg]
LES16	3.0
LESH16	2.0

Applications

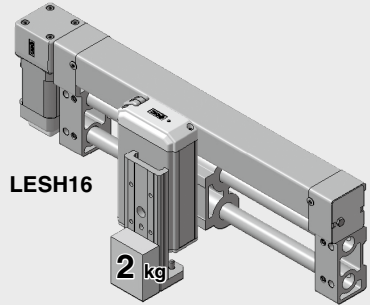
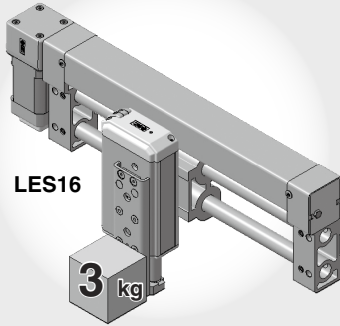

Light weight

Reduced by up to **29%**

Model	Weight [kg]	Reduction amount
LES16D-100	1.20	Reduced by 0.50 kg
LESH16D-100	1.70	

- Max. pushing force: 180 N
- Possible to reduce cycle time
Max. acceleration/deceleration: 5000 mm/s²
Max. speed: 400 mm/s
- Positioning repeatability: ±0.05 mm
- 2 types of motors selectable: Step motor (Servo/24 VDC), Servo motor (24 VDC)

Basic type/R type

LES□R Series



Symmetrical type/L type

LES□L Series



In-line motor type/D type

LES□D Series



High Rigidity Type *LESH Series*

High rigidity Deflection: **0.016 mm*** * LESH16-50 Load: 25 N

Integration of the guide rail and the table
Uses a circulating linear guide.

Positioning pin hole

Improved workpiece mounting reproducibility

Body mounting through-hole

Can be mounted from the top.

Workpiece mounting tap



Compact, Space-saving

For LESH8 R/L, 50 mm stroke

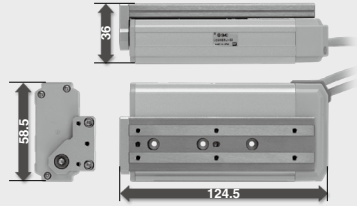

Reduced by 61% in volume*

* Compared with the LESH16-50/LXSH-50
 * For R/L type

Motor integrated into the body

Built-in motor

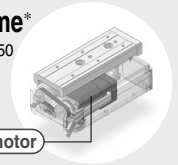

Integration of the guide rail and the table

2 types of motors selectable

- **Step motor (Servo/24 VDC)**
Ideal for transfer of high load at a low speed and pushing operation
- **Servo motor (24 VDC)**
Stable at high speed and silent operation

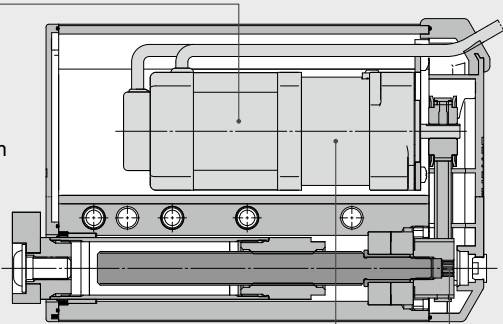
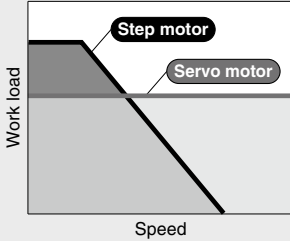

Non-magnetizing lock mechanism (Option)

Prevents workpieces from dropping (holding)

Manual override screw

Adjustment operation possible when power OFF

Application Examples

Positioning of pallets on a conveyor

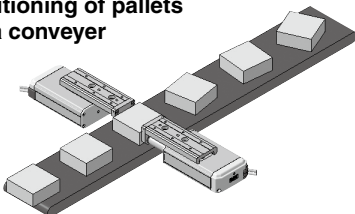

Z motion for pick and place

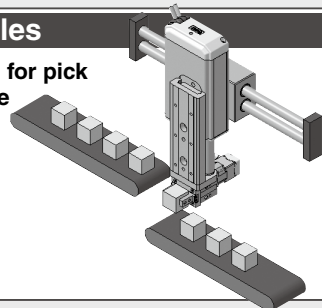

Symmetrical Type/L Type

The locations of the table and cable are opposite those of the basic type (R type), expanding design applications.

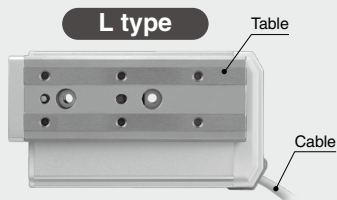
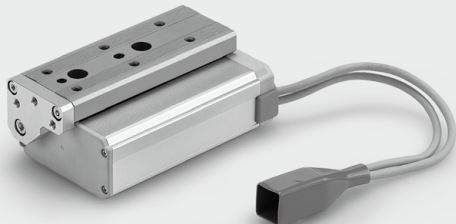

Installation example

When two tables are installed side by side, they will not interfere with each other, allowing for space saving.

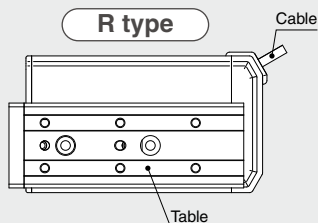
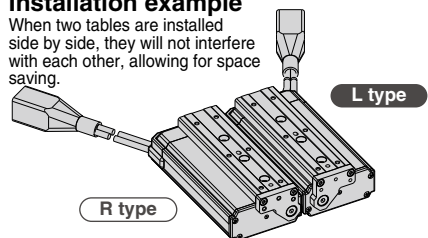

In-line Motor Type/D Type

Width dimension shortened by up to 45%



D type

R type

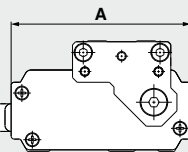
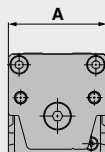

A Dimension

[mm]

Size	D type	R/L type
8	32	58.5
16	45	72.5
25	61	106

How to Mount

Through-hole mounting

(R/L/D type)

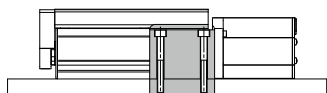

Side holder mounting

(D type)

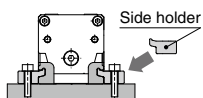

Body tapped mounting

(R/L/D type)

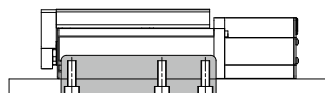

Step Motor (Servo/24 VDC) Servo Motor (24 VDC)

Electric Slide Table/Compact Type *LES Series*



Model Selection	Page 314
How to Order	Pages 324, 325-1
Specifications	Page 326
Construction	Page 328
Dimensions	Page 330

Step Motor (Servo/24 VDC) Servo Motor (24 VDC)

Electric Slide Table/High Rigidity Type *LESH Series*



Model Selection	Page 340
How to Order	Pages 350, 351-1
Specifications	Page 352
Construction	Page 354
Dimensions	Page 356
Specific Product Precautions	Page 366

Step Motor (Servo/24 VDC)/Servo Motor (24 VDC) Controller



Step Data Input Type/ <i>LECP6/LECA6 Series</i>	Page 560
Controller Setting Kit/ <i>LEC-W2</i>	Page 569
Teaching Box/ <i>LEC-T1</i>	Page 570
CC-Link Direct Input Type/ <i>LECPMJ Series</i>	Page 600
Controller Setting Kit/ <i>LEC-W2</i>	Page 603-2
Teaching Box/ <i>LEC-T1</i>	Page 603-3
EtherCAT®/EtherNet/IP™/PROFINET/DeviceNet™/IO-Link Direct Input Type/ <i>JXCE1/91/P1/D1/L1 Series</i>	Page 603-5
Controller Setting Kit/ <i>LEC-W2</i>	Page 603-10
Teaching Box/ <i>LEC-T1</i>	Page 605
Gateway Unit/ <i>LEC-G Series</i>	Page 572
Programless Controller/ <i>LECP1 Series</i>	Page 576
Step Motor Driver/ <i>LECPA Series</i>	Page 590
Controller Setting Kit/ <i>LEC-W2</i>	Page 597
Teaching Box/ <i>LEC-T1</i>	Page 598

4-Axis Step Motor Controller (Servo/24 VDC)



Parallel I/O/ <i>JXC73/83 Series</i>	Page 606-1
EtherNet/IP™ Type/ <i>JXC93 Series</i>	Page 606-1

Slide Tables

Compact Type *LES Series*

Step Motor (Servo/24 VDC)

Servo Motor (24 VDC)

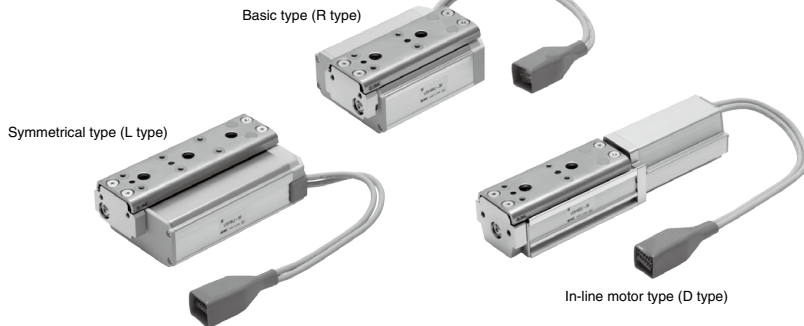

High Rigidity Type *LESH Series*

Step Motor (Servo/24 VDC)

Servo Motor (24 VDC)

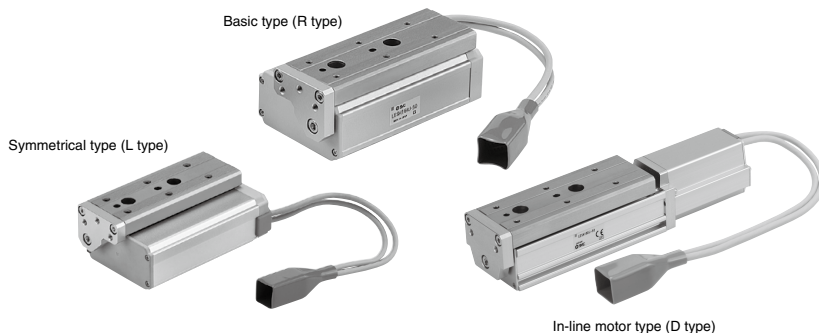

Model Selection 1



LES Series ▶ Pages 324, 325-1

Selection Procedure

For the high rigidity type LESH series, refer to page 340



Selection Example

Step 1 Check the work load-speed. <Speed-Work load graph> (Page 315)
Select the target model based on the workpiece mass and speed with reference to the <Speed-Work load graph>. Selection example) The LES16□J-50 is temporarily selected based on the graph shown on the right side.

Step 2 Check the cycle time.
It is possible to obtain an approximate cycle time by using method 1, but if a more detailed cycle time is required, use method 2.

Method 1: Check the cycle time graph. (Page 316)

Method 2: Calculation <Speed-Work load graph> (Page 315)

Calculate the cycle time using the following calculation method. Calculation example) T1 to T4 can be calculated as follows.

Cycle time:

T can be found from the following equation.

$$T = T1 + T2 + T3 + T4 \text{ [s]}$$

- T1: Acceleration time and T3: Deceleration time can be obtained by the following equation.

$$T1 = V/a1 \text{ [s]} \quad T3 = V/a2 \text{ [s]}$$

- T2: Constant speed time can be found from the following equation.

$$T2 = \frac{L - 0.5 \cdot V \cdot (T1 + T3)}{V} \text{ [s]}$$

- T4: Settling time varies depending on the conditions such as motor types, load and in position of the step data. Therefore, calculate the settling time with reference to the following value.

$$T4 = 0.15 \text{ [s]}$$

$$T1 = V/a1 = 220/5000 = 0.04 \text{ [s]}$$

$$T3 = V/a2 = 220/5000 = 0.04 \text{ [s]}$$

$$T2 = \frac{L - 0.5 \cdot V \cdot (T1 + T3)}{V} = \frac{50 - 0.5 \cdot 220 \cdot (0.04 + 0.04)}{220} = 0.19 \text{ [s]}$$

$$T4 = 0.15 \text{ [s]}$$

Therefore, the cycle time can be obtained as follows.

$$T = T1 + T2 + T3 + T4 = 0.04 + 0.19 + 0.04 + 0.15 = 0.42 \text{ [s]}$$

Operating conditions

- Workpiece mass: 1 [kg]
- Workpiece mounting condition:
- Speed: 220 [mm/s]
- Mounting orientation: Vertical
- Stroke: 50 [mm]
- Acceleration/Deceleration: 5000 [mm/s²]
- Cycle time: 0.5 seconds

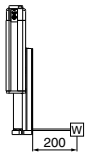

LES16□/Step Motor Vertical

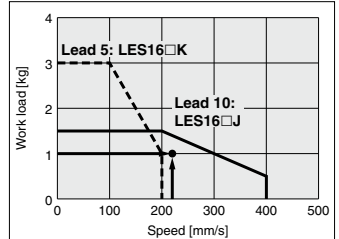

<Speed-Work load graph>

LES16□/Step Motor

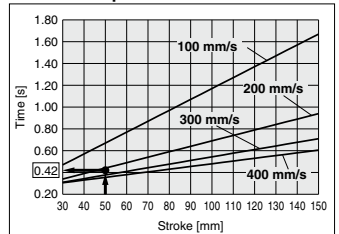

<Cycle time>

Step 3 Check the allowable moment. <Static allowable moment> (Page 316)

<Dynamic allowable moment> (Pages 317, 318)

Confirm the moment that applies to the actuator is within the allowable range for both static and dynamic conditions.

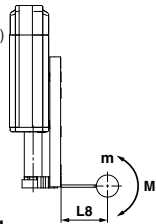

LES16/Pitching

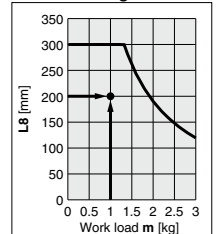

<Dynamic allowable moment>

Based on the above calculation result, the LES16□J-50 is selected.

Speed-Work Load Graph (Guide)

Step Motor (Servo/24 VDC)

* The following graph shows the values when moving force is 100%.

LES8□

Horizontal

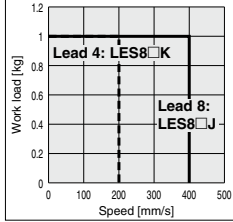

Vertical

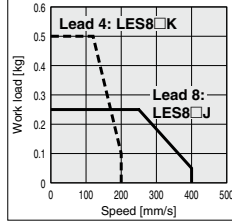

LES16□

Horizontal

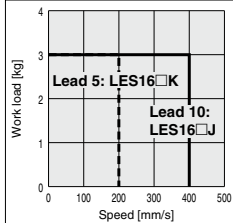

Vertical

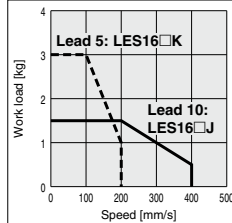

LES25□

Horizontal

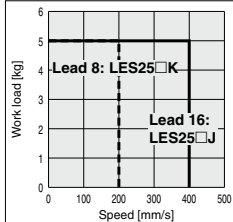

Vertical

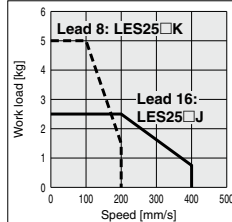

Servo Motor (24 VDC)

* The following graph shows the values when moving force is 250%.

LES8□A

Horizontal

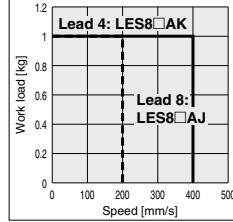

Vertical

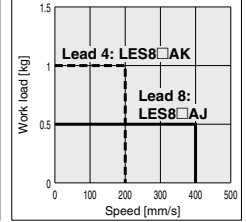

LES16□A

Horizontal

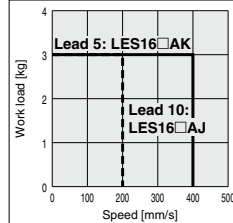

Vertical

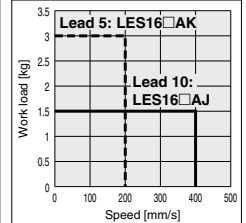

LES25^R□A

Horizontal

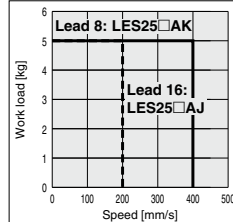

Vertical

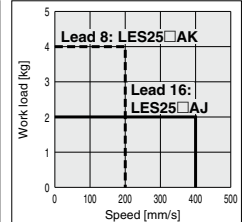

LES Series

Step Motor (Servo/24 VDC)

Servo Motor (24 VDC)

Cycle Time (Guide)

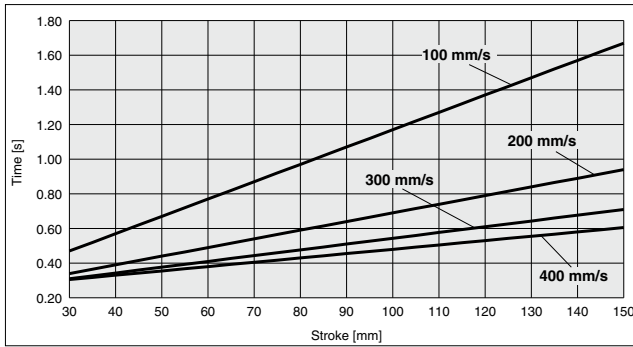

Operating Conditions

Acceleration/Deceleration: 5000 mm/s²

In position: 0.5 mm

Static Allowable Moment

Model		LES8	LES16	LES25
Pitching	[N·m]	2	4.8	14.1
Yawing	[N·m]	2	4.8	14.1
Rolling	[N·m]	0.8	1.8	4.8

* This graph shows the amount of allowable overhang (guide unit) when the center of gravity of the workpiece overhangs in one direction. When selecting the overhang, refer to "Calculation of Guide Load Factor" or the Electric Actuator Selection Software for confirmation, <http://www.smcworld.com>

Dynamic Allowable Moment

Acceleration/Deceleration — 5000 mm/s²

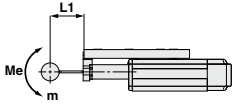
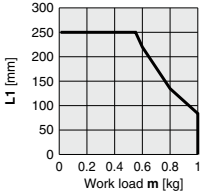
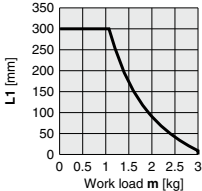
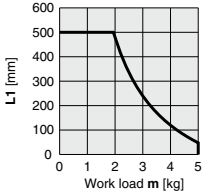
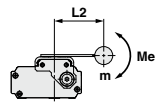
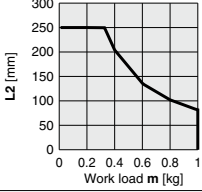
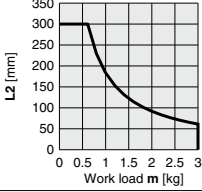
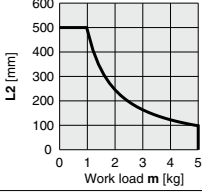
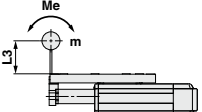
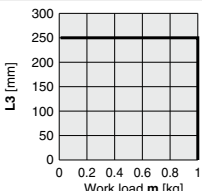
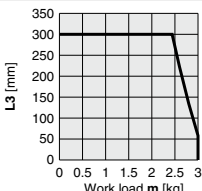
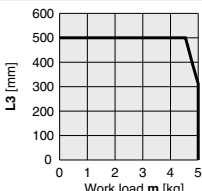
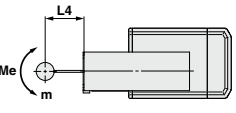
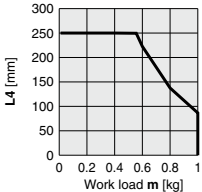
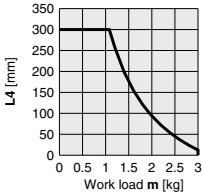
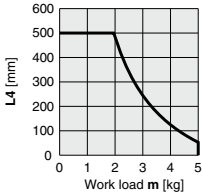
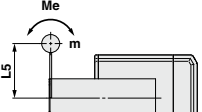
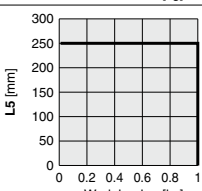
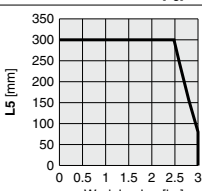
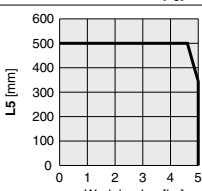
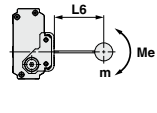
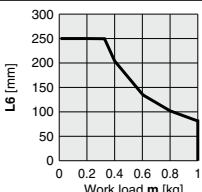
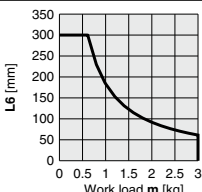
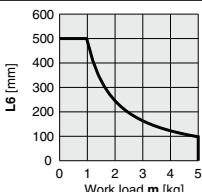
Orientation	Load overhanging direction m : Work load [kg] Me: Dynamic allowable moment [N·m] L : Overhang to the work load center of gravity [mm]	Model		
		LES8	LES16	LES25
Horizontal/Bottom	X 			
	Y 			
	Z 			
Wall	X 			
	Y 			
	Z 			

* This graph shows the amount of allowable overhang (guide unit) when the center of gravity of the workpiece overhangs in one direction. When selecting the overhang, refer to "Calculation of Guide Load Factor" or the Electric Actuator Selection Software for confirmation, <http://www.smcworld.com>

Dynamic Allowable Moment

Acceleration/Deceleration — 5000 mm/s²

Orientation	Load overhanging direction m : Work load [kg] Me: Dynamic allowable moment [N·m] L : Overhang to the work load center of gravity [mm]	Model		
		LES8	LES16	LES25
Vertical	Y			
	Z			

Calculation of Guide Load Factor

- Decide operating conditions.

Model: LES

Size: 8/16/25

Mounting orientation: Horizontal/Bottom/Wall/Vertical

- Select the target graph with reference to the model, size and mounting orientation.
- Based on the acceleration and work load, obtain the overhang [mm]: $L_x/L_y/L_z$ from the graph.
- Calculate the load factor for each direction.

$$\alpha_x = X_c/L_x, \alpha_y = Y_c/L_y, \alpha_z = Z_c/L_z$$

- Confirm the total of α_x , α_y and α_z is 1 or less.

$$\alpha_x + \alpha_y + \alpha_z \leq 1$$

When 1 is exceeded, please consider a reduction of acceleration and work load, or a change of the work load center position and series.

Acceleration [mm/s²]: a

Work load [kg]: m

Work load center position [mm]: $X_c/Y_c/Z_c$

Mounting orientation

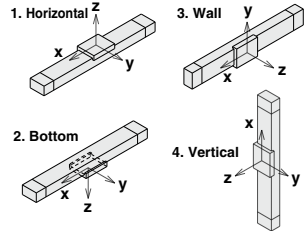

Example

- Operating conditions

Model: LES

Size: 8

Mounting orientation: Horizontal

Acceleration [mm/s²]: 5000

Work load [kg]: 0.6

Work load center position [mm]: $X_c = 50, Y_c = 30, Z_c = 60$

- Select three graphs from the top of the left side first row on page 317.

- $L_x = 220$ mm, $L_y = 135$ mm, $L_z = 250$ mm

- The load factor for each direction can be obtained as follows.

$$\alpha_x = 50/220 = 0.23$$

$$\alpha_y = 30/135 = 0.22$$

$$\alpha_z = 60/250 = 0.24$$

- $\alpha_x + \alpha_y + \alpha_z = 0.69 \leq 1$

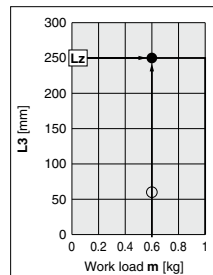
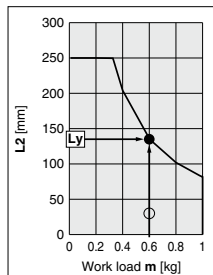
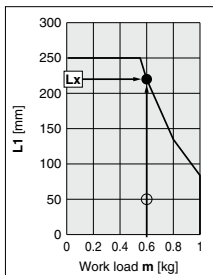

Electric Slide Table/Compact Type
LES Series

Model Selection 2



LES Series Pages 324, 325-1

Selection Procedure For the high rigidity type LESH series, refer to page 346.

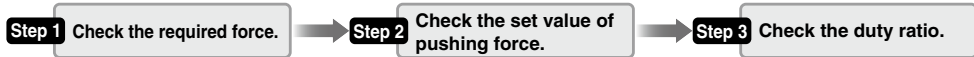

Selection Example

Operating conditions

- Pushing force: 90 [N]
- Workpiece mass: 1 [kg]
- Speed: 100 [mm/s]
- Stroke: 100 [mm]
- Mounting orientation: Vertical upward
- Pushing time + Operation (A): 1.5 seconds
- All cycle time (B): 6 seconds

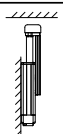

Step 1 Check the required force.

Calculate the approximate required force for pushing operation.
Selection example) • Pushing force: 90 [N]

- Workpiece mass: 1 [kg]
- Therefore, the approximate required force can be obtained as $90 + 10 = 100$ [N].

Select the target model based on the approximate required force with reference to the specifications (Pages 326 and 327).

- Selection example) Based on the specifications,
- Approximate required force: 100 [N]
 - Speed: 100 [mm/s]
- Therefore, the LES25□ is temporarily selected.

Then, calculate the required force for pushing operation.
If the mounting position is vertical upward, add the actuator table weight.

- Selection example) Based on the <Table weight>,
• LES25□ table weight: 0.5 [kg]
- Therefore, the required force can be obtained as $100 + 5 = 105$ [N].

Step 2 Check the set value of pushing force.

<Set value of pushing force–Force graph> (Page 321)

Select the target model based on the required force with reference to the <Set value of pushing force–Force graph>, and confirm the set value of pushing force.

- Selection example) Based on the graph shown on the right side,
- Required force: 105 [N]
- Therefore, the LES25□K is temporarily selected.
This set value of pushing force is 40 [%].

Step 3 Check the duty ratio.

Confirm the allowable duty ratio based on the set value of pushing force with reference to the <Allowable duty ratio>.
Selection example) Based on the <Allowable duty ratio>,
• Set value of pushing force: 40 [%]

Therefore, the allowable duty ratio can be obtained as 30 [%].

Calculate the duty ratio for operating conditions, and confirm it does not exceed the allowable duty ratio.

- Selection example) • Pushing time + Operation (A): 1.5 seconds
- All cycle time (B): 6 seconds
- Therefore, the duty ratio can be obtained as $1.5/6 \times 100 = 25$ [%], and this is the allowable range.

Based on the above calculation result, the LES25□K-100 is selected.

For allowable moment, the selection procedure is the same as the positioning control.

Table Weight [kg]

Model	Stroke [mm]					
	30	50	75	100	125	150
LES8	0.06	0.08	0.10	—	—	—
LES16	0.10	0.13	0.18	0.20	—	—
LES25	0.25	0.30	0.36	0.50	0.55	0.59

* If the mounting position is vertical upward, add the table weight.

LES25□/Step Motor

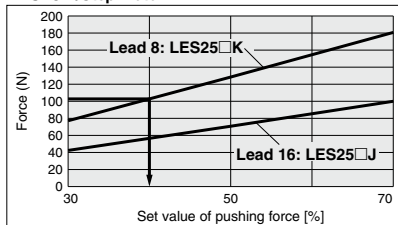

<Set value of pushing force–Force graph>

Allowable Duty Ratio

Step Motor (Servo/24 VDC)

Set value of pushing force (%)	Duty ratio (%)	Continuous pushing time (minute)
30	—	—
50 or less	30 or less	5 or less
70 or less	20 or less	3 or less

Servo Motor (24 VDC)

Set value of pushing force (%)	Duty ratio (%)	Continuous pushing time (minute)
50	—	—
75 or less	30 or less	5 or less
100 or less	20 or less	3 or less

* The pushing force of the LES8□A is up to 75%.

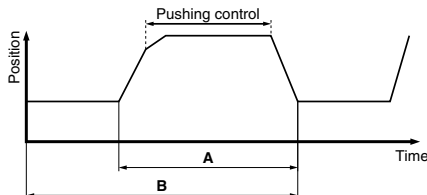

Set Value of Pushing Force–Force Graph

Step Motor (Servo/24 VDC)

LES8□

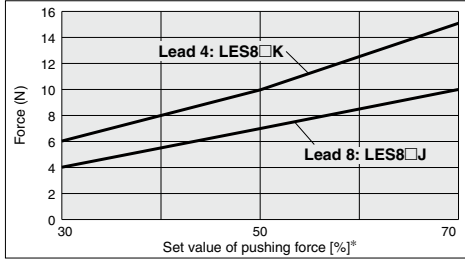

LES16□

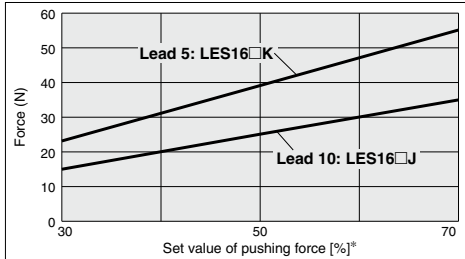

LES25□

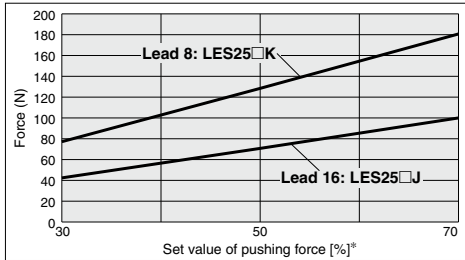

Servo Motor (24 VDC)

LES8□A

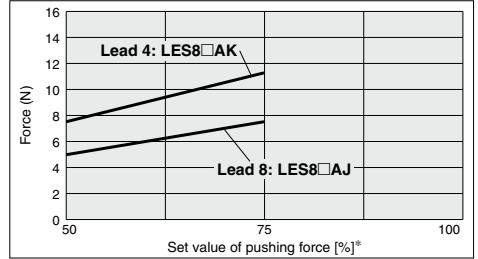

LES16□A

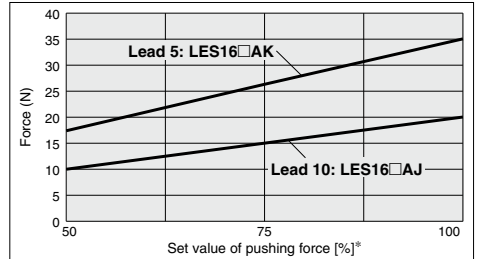

LES25^R□A

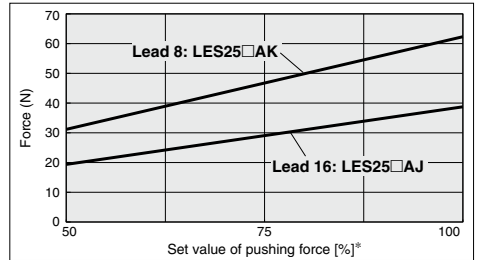

* Set values for the controller.

LES Series

Step Motor (Servo/24 VDC)

Servo Motor (24 VDC)

Table Accuracy

* These values are initial guideline values.

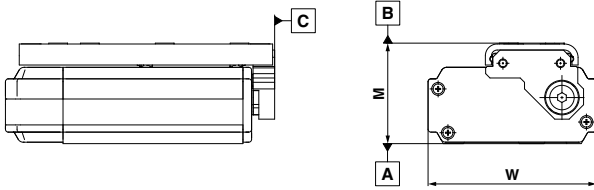

Model	LES8	LES16	LES25
B side parallelism to A side	0.4 mm		
B side traveling parallelism to A side	Refer to Graph 1.		
C side perpendicularity to A side	0.2 mm		
M dimension tolerance	±0.3 mm		
W dimension tolerance	±0.2 mm		

Graph 1 B side traveling parallelism to A side

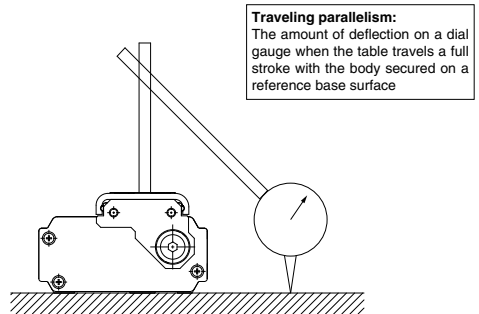
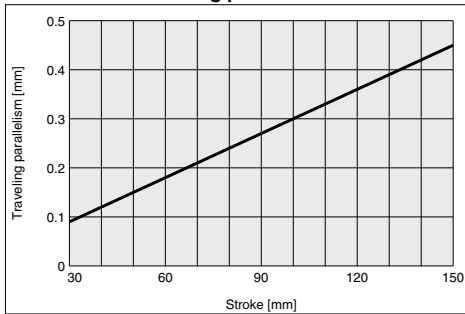

Table Deflection (Reference Value)

* These values are initial guideline values.

Pitching moment

Table displacement due to pitch moment load
 Table displacement when loads are applied to the section marked with the arrow with the slide table stuck out.



LES8

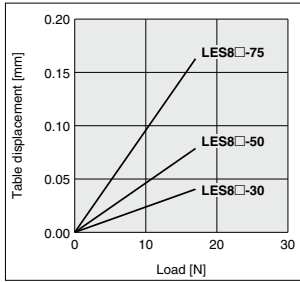

Yawing moment

Table displacement due to yaw moment load
 Table displacement when loads are applied to the section marked with the arrow with the slide table stuck out.

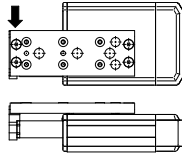

LES8

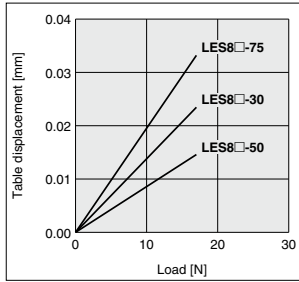

Rolling moment

Table displacement due to roll moment load
 Table displacement of section A when loads are applied to the section F with the slide table retracted.

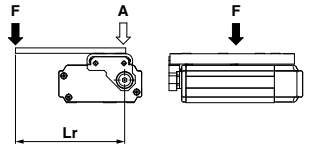

LES8

$L_r = 80$ mm

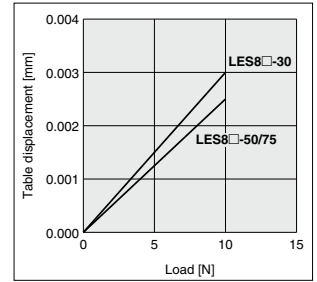

LES16

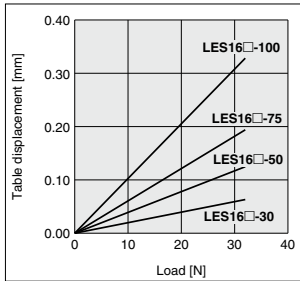

LES16

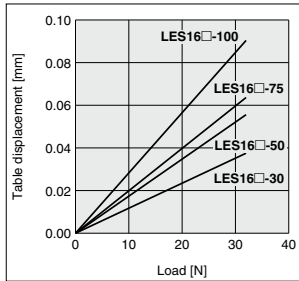

LES16

$L_r = 60$ mm

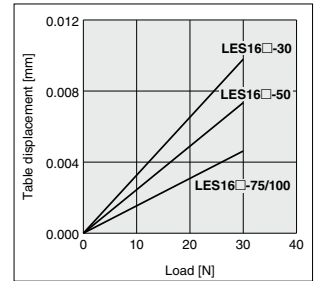

LES25

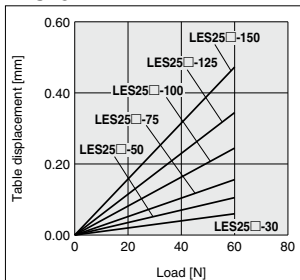

LES25

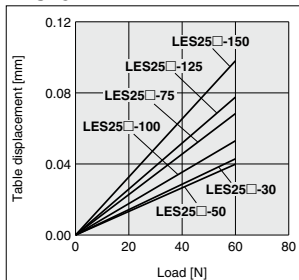

LES25

$L_r = 100$ mm

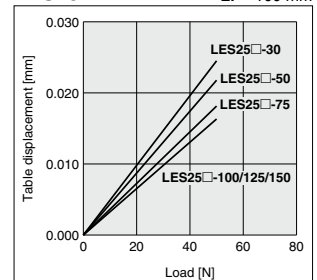

Electric Slide Table/ Compact Type

LES Series LES8, 16, 25

Applicable to the
LEC□ series



Refer to page 325-1 for the communication protocols EtherCAT®, EtherNet/IP™, PROFINET, DeviceNet™, and IO-Link.

How to Order

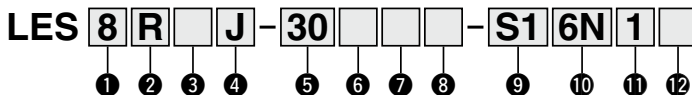

1 Size

8
16
25

2 Motor mounting position

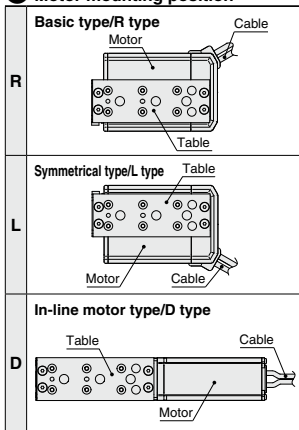

3 Motor type

Symbol	Type	Compatible controller/driver
Nil	Step motor (Servo/24 VDC)	LECP6 LECP1 LECPA LECPMJ
A	Servo motor* (24 VDC)	LECA6

* LES25DA is not available.

⚠ Caution

[CE-compliant products]

① EMC compliance was tested by combining the electric actuator LES series and the controller LEC series.

The EMC depends on the configuration of the customer's control panel and the relationship with other electrical equipment and wiring. Therefore, conformity to the EMC directive cannot be certified for SMC components incorporated into the customer's equipment under actual operating conditions. As a result, it is necessary for the customer to verify conformity to the EMC directive for the machinery and equipment as a whole.

② For the servo motor (24 VDC) specification, EMC compliance was tested by installing a noise filter set (LEC-NFA).

Refer to page 568 for the noise filter set. Refer to the LECA Operation Manual for installation.

③ CC-Link direct input type (LECPMJ) is not CE-compliant.

[UL-compliant products]

When conformity to UL is required, the electric actuator and controller/driver should be used with a UL1310 Class 2 power supply.

4 Lead [mm]

Symbol	LES8	LES16	LES25
J	8	10	16
K	4	5	8

5 Stroke [mm]

Stroke	30	50	75	100	125	150
Model						
LES8	●*	●*	●	—	—	—
LES16	●*	●*	●	●	—	—
LES25	●*	●	●	●	●	●

* R/L type with lock is not available.

6 Motor option

Nil	Without option
B	With lock

7 Body option

Nil	Without option
S	Dust-protected*

* For R/L type (IP5X equivalent), a scraper is mounted on the rod cover, and gaskets are mounted on both the end covers. For D type, a scraper is mounted on the rod cover.

The actuator and controller/driver are sold as a package.

Confirm that the combination of the controller/driver and the actuator is correct.

<Check the following before use.>

- Check the actuator label for model number. This matches the controller/driver.
- Check Parallel I/O configuration matches (NPN or PNP).

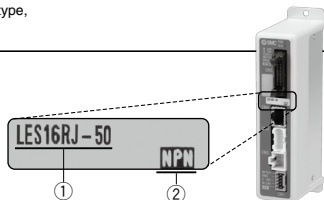

* Refer to the operation manual for using the products. Please download it via our website, <http://www.smcworld.com>

Electric Slide Table/Compact Type **LES Series**

Step Motor (Servo/24 VDC) Servo Motor (24 VDC)



Basic type (R type)



Symmetrical type (L type)



In-line motor type (D type)

8 Mounting*

Symbol	Mounting	R type L type	D type
Nil	Without side holder	●	●
H	With side holder (4 pcs.)	—	●

* Refer to page 339 for details.

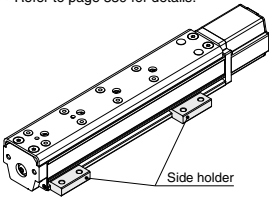

9 Actuator cable type/length*2

	Without cable
Nil	Without cable
S1	Standard cable 1.5 m*3
S3	Standard cable 3 m*3
S5	Standard cable 5 m*3
R1	Robotic cable 1.5 m
R3	Robotic cable 3 m
R5	Robotic cable 5 m
R8	Robotic cable 8 m*1
RA	Robotic cable 10 m*1
RB	Robotic cable 15 m*1
RC	Robotic cable 20 m*1

*1 Produced upon receipt of order (Robotic cable only)

*2 The standard cable should only be used on fixed parts.

For use on moving parts, select the robotic cable.

*3 Only available for the motor type "Step motor."

10 Controller/Driver type*1

Nil	Without controller/driver	
6N	LECP6/LECA6 (Step data input type)	NPN
6P		PNP
1N	LECP1*2 (Programless type)	NPN
1P		PNP
MJ	LECPMJ*2 *3 (CC-Link direct input type)	—
AN	LECPA*2 *4 (Pulse input type)	NPN
AP		PNP

*1 For details about controller/driver and compatible motor, refer to the compatible controller/driver below.

*2 Only available for the motor type "Step motor."

*3 Not applicable to CE.

*4 When pulse signals are open collector, order the current limiting resistor (LEC-PA-R-□) on page 596 separately.

11 I/O cable length*1, Communication plug

Nil	Without cable (Without communication plug connector)*3
1	1.5 m
3	3 m*2
5	5 m*2
S	Straight type communication plug connector*3
T	T-branch type communication plug connector*3

*1 When "Without controller/driver" is selected for controller/driver types, I/O cable cannot be selected. Refer to page 568 (For LECP6/LECA6), page 582 (For LECP1) or page 596 (For LECPA) if I/O cable is required.

*2 When "Pulse input type" is selected for controller/driver types, pulse input usable only with differential. Only 1.5 m cables usable with open collector.

*3 For the LECPMJ, only "Nil", "S" and "T" are selectable since I/O cable is not included.

12 Controller/Driver mounting

Nil	Screw mounting
D	DIN rail mounting*

* DIN rail is not included. Order it separately.

Compatible Controller/Driver

Type	Step data input type	Step data input type	CC-Link direct input type	Programless type	Pulse input type
Series	LECP6	LECA6	LECPMJ	LECP1	LECPA
Features	Value (Step data) input Standard controller		CC-Link direct input	Capable of setting up operation (step data) without using a PC or teaching box	Operation by pulse signals
Compatible motor	Step motor (Servo/24 VDC)	Servo motor (24 VDC)		Step motor (Servo/24 VDC)	
Maximum number of step data	64 points			14 points	—
Power supply voltage	24 VDC				
Reference page	Page 560	Page 560	Page 600	Page 576	Page 590

Electric Slide Table/ Compact Type

LES Series LES8, 16, 25



Applicable to the
JXC□ series

How to Order

Refer to page 324 for the communication protocol CC-Link.

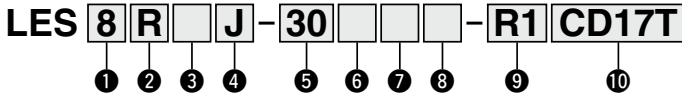

1 Size

8
16
25

2 Motor mounting position

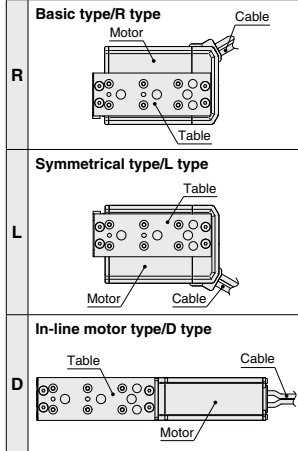

3 Motor type

Symbol	Type	Compatible controller
Nil	Step Motor (Servo/24 VDC)	JXCE1 JXC91 JXCP1 JXCD1 JXCL1

⚠ Caution

[CE-compliant products]

EMC compliance was tested by combining the electric actuator LE series and the JXCE1/91/P1/D1/L1 series.

The EMC depends on the configuration of the customer's control panel and the relationship with other electrical equipment and wiring. Therefore, conformity to the EMC directive cannot be certified for SMC components incorporated into the customer's equipment under actual operating conditions. As a result, it is necessary for the customer to verify conformity to the EMC directive for the machinery and equipment as a whole.

4 Lead [mm]

Symbol	LES8	LES16	LES25
J	8	10	16
K	4	5	8

5 Stroke [mm]

Stroke	30	50	75	100	125	150
Model						
LES8	●*	●*	●	—	—	—
LES16	●*	●*	●	●	—	—
LES25	●*	●	●	●	●	●

* R/L type with lock is not available.

6 Motor option

Nil	Without option
B	With lock

7 Body option

Nil	Without option
S	Dust-protected*

* For R/L type (IP5X equivalent), a scraper is mounted on the rod cover, and gaskets are mounted on both the end covers. For D type, a scraper is mounted on the rod cover.

Electric Slide Table/Compact Type **LES Series**

Step Motor (Servo/24 VDC) Servo Motor (24 VDC)



Basic type (R type)



Symmetrical type (L type)



In-line motor type (D type)

8 Mounting*

Symbol	Mounting	R type L type	D type
Nil	Without side holder	●	●
H	With side holder (4 pcs.)	—	●

* Refer to page 339 for details.

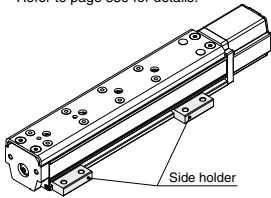

9 Actuator cable type/length

Nil	Without cable
S1	Standard cable 1.5 m
S3	Standard cable 3 m
S5	Standard cable 5 m
R1	Robotic cable 1.5 m
R3	Robotic cable 3 m
R5	Robotic cable 5 m
R8	Robotic cable 8 m*1
RA	Robotic cable 10 m*1
RB	Robotic cable 15 m*1
RC	Robotic cable 20 m*1

*1 Produced upon receipt of order (Robotic cable only)

*2 The standard cable should only be used on fixed parts.
For use on moving parts, select the robotic cable.

10 Controller

Nil	Without controller
C□1□□	With controller

C D 1 7 T

Communication protocol

E	EtherCAT®
9	EtherNet/IP™
P	PROFINET
D	DeviceNet™
L	IO-Link

For single axis

Mounting

7	Screw mounting
8*	DIN rail

* DIN rail is not included. It must be ordered separately. (Page 603-8)

Communication plug

connector for DeviceNet™

Nil	Without plug connector
S	Straight type
T	T-branch type

* Select "Nil" for anything other than DeviceNet™.

Compatible Controller

Type	EtherCAT® direct input type	EtherNet/IP™ direct input type	PROFINET direct input type	DeviceNet™ direct input type	IO-Link direct input type
Series	JXCE1	JXC91	JXCP1	JXCD1	JXCL1
Features	EtherCAT® direct input	EtherNet/IP™ direct input	PROFINET direct input	DeviceNet™ direct input	IO-Link direct input
Compatible motor	Step motor (Servo/24 VDC)				
Maximum number of step data	64 points				
Power supply voltage	24 VDC				
Reference page	Page 603-5				

Specifications

Step Motor (Servo/24 VDC)

Model		LES8□		LES16□		LES25□		
Actuator specifications	Stroke [mm]	30, 50, 75		30, 50, 75, 100		30, 50, 75, 100, 125, 150		
	Work load [kg] ^{Note 1)}	Horizontal		3		5		
		Vertical		0.5	0.25	3	1.5	5
	Pushing force 30 to 70 % [N] ^{Note 2) 3)}		6 to 15	4 to 10	23.5 to 55	15 to 35	77 to 180	43 to 100
	Speed [mm/s] ^{Note 1) 3)}		10 to 200	20 to 400	10 to 200	20 to 400	10 to 200	20 to 400
	Pushing speed [mm/s]		10 to 20	20	10 to 20	20	10 to 20	20
	Max. acceleration/deceleration [mm/s ²]		5000					
	Positioning repeatability [mm]		±0.05					
	Lost motion [mm] ^{Note 4)}		0.3 or less					
	Screw lead [mm]		4	8	5	10	8	16
	Impact/Vibration resistance [m/s ²] ^{Note 5)}		50/20					
	Actuation type		Slide screw + Belt (R/L type), Slide screw (D type)					
Guide type		Linear guide (Circulating type)						
Operating temperature range [°C]		5 to 40						
Operating humidity range [%RH]		90 or less (No condensation)						
Electric specifications	Motor size	□20		□28		□42		
	Motor type	Step motor (Servo/24 VDC)						
	Encoder	Incremental A/B phase (800 pulse/rotation)						
	Rated voltage [V]	24 VDC ±10%						
	Power consumption [W] ^{Note 6)}	18		69		45		
Standby power consumption when operating [W] ^{Note 7)}	7		15		13			
Max. instantaneous power consumption [W] ^{Note 8)}	35		69		67			
Lock with specifications	Type	Non-magnetizing lock						
	Holding force [N] ^{Note 9)}	24	2.5	300	48	500	77	
	Power consumption [W] ^{Note 10)}	3.5		2.9		5		
Rated voltage [V]	24 VDC ±10%							

Note 1) Speed changes according to the work load. Check "Speed-Work Load Graph (Guide)" on page 315.

Note 2) Pushing force accuracy is ±20% (F.S.).

Note 3) The speed and force may change depending on the cable length, load and mounting conditions. Furthermore, if the cable length exceeds 5 m, then it will decrease by up to 10% for each 5 m. (At 15 m: Reduced by up to 20%)

Note 4) A reference value for correcting an error in reciprocal operation.

Note 5) Vibration resistance: No malfunction occurred in a test ranging between 45 to 2000 Hz. Test was performed in both an axial direction and a perpendicular direction to the lead screw. (Test was performed with the actuator in the initial state.)

Impact resistance: No malfunction occurred when the actuator was tested with a drop tester in both an axial direction and a perpendicular direction to the lead screw. (Test was performed with the actuator in the initial state.)

Note 6) The power consumption (including the controller) is for when the actuator is operating.

Note 7) The standby power consumption when operating (including the controller) is for when the actuator is stopped in the set position during the operation. Except during the pushing operation.

Note 8) The maximum instantaneous power consumption (including the controller) is for when the actuator is operating. This value can be used for the selection of the power supply.

Note 9) With lock only

Note 10) For an actuator with lock, add the power consumption for the lock.

Specifications

Servo Motor (24 VDC)

Model		LES8□A		LES16□A		LES25□A ^{Note 1)}			
Actuator specifications	Stroke [mm]	30, 50, 75		30, 50, 75, 100		30, 50, 75, 100, 125, 150			
	Work load [kg]	Horizontal		1		3		5	
		Vertical		1	0.5	3	1.5	4	2
	Pushing force 50 to 100% [N] ^{Note 2)}	7.5 to 11	5 to 7.5	17.5 to 35	10 to 20	31 to 62	19 to 38		
	Speed [mm/s]	1 to 200	1 to 400	1 to 200	1 to 400	1 to 200	1 to 400		
	Pushing speed [mm/s]	1 to 20							
	Max. acceleration/deceleration [mm/s ²]	5000							
	Positioning repeatability [mm]	±0.05							
	Lost motion [mm] ^{Note 3)}	0.3 or less							
	Screw lead [mm]	4	8	5	10	8	16		
	Impact/Vibration resistance [m/s ²] ^{Note 4)}	50/20							
Actuation type	Slide screw + Belt (R/L type), Slide screw (D type)								
Guide type	Linear guide (Circulating type)								
Operating temperature range [°C]	5 to 40								
Operating humidity range [%RH]	90 or less (No condensation)								
Electric specifications	Motor size	□20		□28		□42			
	Motor output [W]	10		30		36			
	Motor type	Servo motor (24 VDC)							
	Encoder (Angular displacement sensor)	Incremental A/B/Z phase (800 pulse/rotation)							
	Rated voltage [V]	24 VDC ±10%							
	Power consumption [W] ^{Note 5)}	42		68		97			
	Standby power consumption when operating [W] ^{Note 6)}	8 (Horizontal)/19 (Vertical)		9 (Horizontal)/23 (Vertical)		16 (Horizontal)/32 (Vertical)			
Max. instantaneous power consumption [W] ^{Note 7)}	71		102		111				
Lock unit specifications	Type	Non-magnetizing lock							
	Holding force [N] ^{Note 8)}	24	2.5	300	48	500	77		
	Power consumption [W] ^{Note 9)}	3.5		2.9		5			
	Rated voltage [V]	24 VDC ±10%							

Note 1) LES25DA is not available.

Note 2) The pushing force values for LES8□A is 50 to 75%. Pushing force accuracy is ±20% (F.S.).

Note 3) A reference value for correcting an error in reciprocal operation.

Note 4) Vibration resistance: No malfunction occurred in a test ranging between 45 to 2000 Hz. Test was performed in both an axial direction and a perpendicular direction to the lead screw. (Test was performed with the actuator in the initial state.)

Impact resistance: No malfunction occurred when the actuator was tested with a drop tester in both an axial direction and a perpendicular direction to the lead screw. (Test was performed with the actuator in the initial state.)

Note 5) The power consumption (including the controller) is for when the actuator is operating.

Note 6) The standby power consumption when operating (including the controller) is for when the actuator is stopped in the set position during the operation. Except during the pushing operation.

Note 7) The maximum instantaneous power consumption (including the controller) is for when the actuator is operating. This value can be used for the selection of the power supply.

Note 8) With lock only

Note 9) For an actuator with lock, add the power consumption for the lock.

Weight

Step Motor (Servo/24 VDC), Servo Motor (24 VDC) Common

[kg]

Stroke [mm]		Without lock					With lock						
		30	50	75	100	125	150	30	50	75	100	125	150
Model	LES8□(A)	0.45	0.54	0.59	—	—	—	—	—	0.66	—	—	—
	LES16□(A)	0.91	1.00	1.16	1.24	—	—	—	—	1.29	1.37	—	—
	LES25□(A)	1.81	2.07	2.41	3.21	3.44	3.68	—	2.34	2.68	3.48	3.71	3.95
	LES8D(A)	0.40	0.52	0.58	—	—	—	0.47	0.59	0.65	—	—	—
	LES16D(A)	0.77	0.90	1.11	1.20	—	—	0.90	1.03	1.25	1.33	—	—
	LES25D	1.82	2.05	2.35	3.07	3.27	3.47	2.08	2.31	2.61	3.33	3.53	3.74

LES Series

Step Motor (Servo/24 VDC)

Servo Motor (24 VDC)

Construction: Basic Type/R Type, Symmetrical Type/L Type

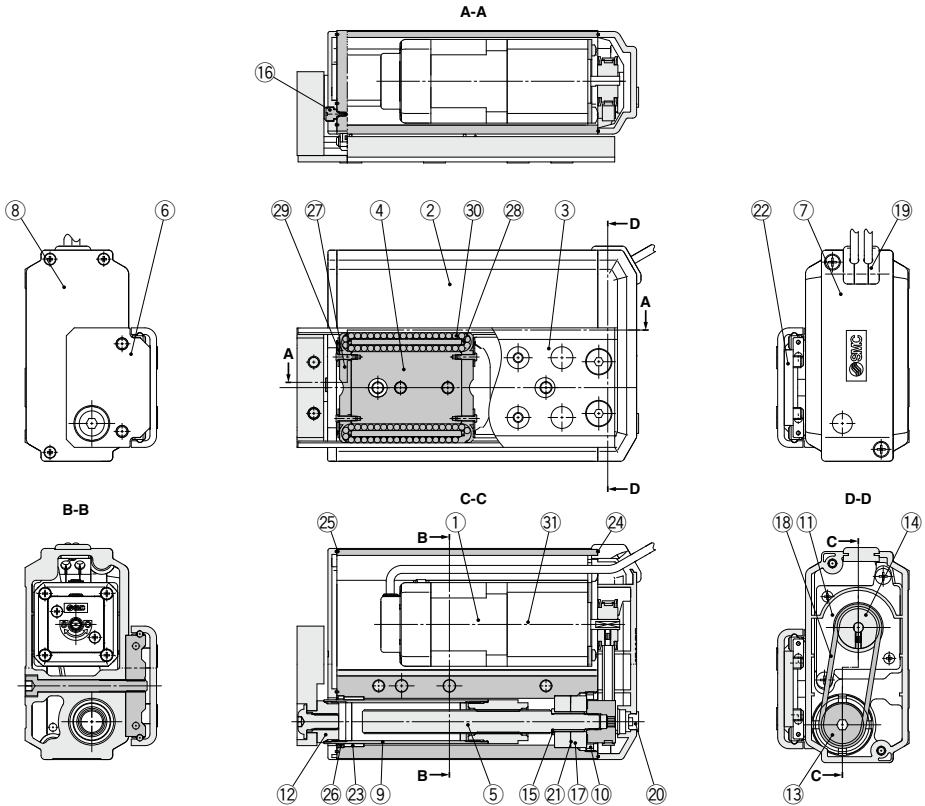

Component Parts

No.	Description	Material	Note
1	Motor	—	—
2	Body	Aluminum alloy	Anodized
3	Table	Stainless steel	Heat treatment + Electroless nickel plating
4	Guide block	Stainless steel	Heat treatment
5	Lead screw	Stainless steel	Heat treatment + Specially treated
6	End plate	Aluminum alloy	Anodized
7	Pulley cover	Synthetic resin	—
8	End cover	Synthetic resin	—
9	Rod	Stainless steel	—
10	Bearing stopper	Structural steel Brass	Electroless nickel plating Electroless nickel plating (LES25R/L□ only)
11	Motor plate	Structural steel	—
12	Socket	Structural steel	Electroless nickel plating
13	Lead screw pulley	Aluminum alloy	—
14	Motor pulley	Aluminum alloy	—
15	Spacer	Stainless steel	LES25R/L□ only
16	Origin stopper	Structural steel	Electroless nickel plating
17	Bearing	—	—
18	Belt	—	—
19	Grommet	Synthetic resin	—
20	Cap	SI	—
21	Sim ring	Structural steel	—

No.	Description	Material	Note
22	Stopper	Structural steel	—
23	Bushing	—	Dust-protected option only
24	Pulley gasket	NBR	Dust-protected option only
25	End gasket	NBR	Dust-protected option only
26	Scraper	NBR	Dust-protected option only
27	Cover	Synthetic resin	—
28	Return guide	Synthetic resin	—
29	Cover support	Stainless steel	—
30	Steel ball	Special steel	—
31	Lock	—	With lock only

Replacement Parts/Belt

Size	Order no.	Note
LES8□	LE-D-1-1	Without manual override screw
LES16□	LE-D-1-2	—
LES25□	LE-D-1-3	—
LES25□A	LE-D-1-4	—
LES8□	LE-D-1-5	With manual override screw

Replacement Parts/Grease Pack

Applied portion	Order no.
Guide unit	GR-S-010 (10 g) GR-S-020 (20 g)

Construction: In-line Motor Type/D Type

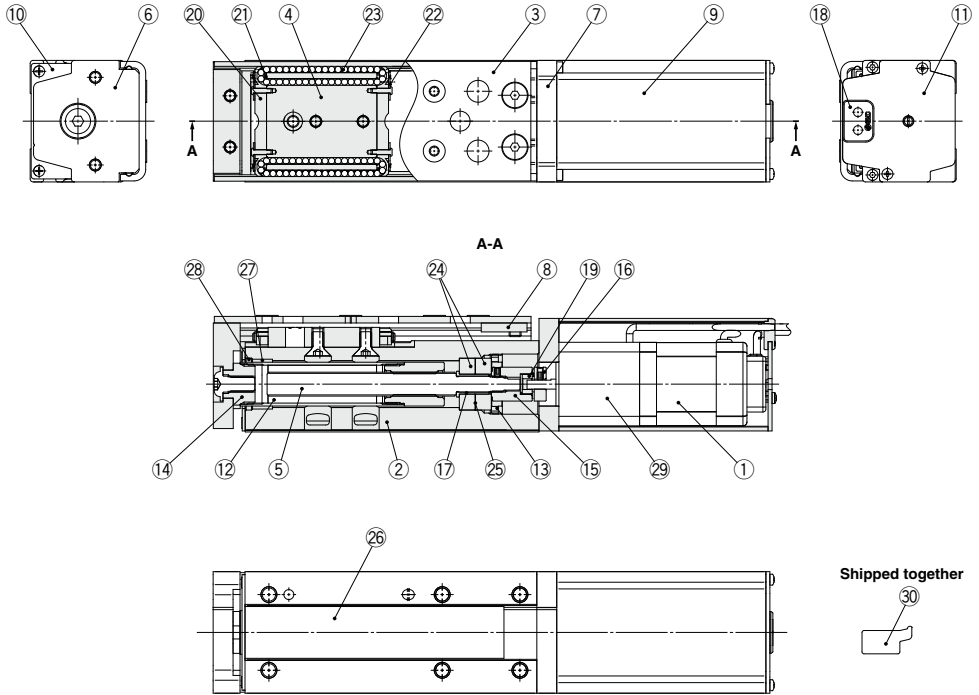

Component Parts

No.	Description	Material	Note
1	Motor	—	—
2	Body	Aluminum alloy	Anodized
3	Table	Stainless steel	Heat treatment + Electroless nickel plating
4	Guide block	Stainless steel	Heat treatment
5	Lead screw	Stainless steel	Heat treatment + Specially treated
6	End plate	Aluminum alloy	Anodized
7	Motor flange	Aluminum alloy	Anodized
8	Stopper	Structural steel	—
9	Motor cover	Aluminum alloy	Anodized
10	End cover	Aluminum alloy	Anodized
11	Motor end cover	Aluminum alloy	Anodized
12	Rod	Stainless steel	—
13	Bearing stopper	Structural steel	Electroless nickel plating
		Brass	Electroless nickel plating (LES25D□ only)
14	Socket	Structural steel	Electroless nickel plating
15	Hub (Lead screw side)	Aluminum alloy	—
16	Hub (Motor side)	Aluminum alloy	—
17	Spacer	Stainless steel	LES25D□ only
18	Grommet	NBR	—
19	Spider	NBR	—
20	Cover	Synthetic resin	—

No.	Description	Material	Note
21	Return guide	Synthetic resin	—
22	Cover support	Stainless steel	—
23	Steel ball	Special steel	—
24	Bearing	—	—
25	Sim ring	Structural steel	—
26	Masking tape	—	—
27	Bushing	—	Dust-protected option only
28	Scraper	NBR	Dust-protected option only
29	Lock	—	With lock only
30	Side holder	Aluminum alloy	Anodized

Optional Parts/Side Holder

Model	Order no.
LES8D	LE-D-3-1
LES16D	LE-D-3-2
LES25D	LE-D-3-3

Replacement Parts/Grease Pack

Applied portion	Order no.
Guide unit	GR-S-010 (10 g) GR-S-020 (20 g)

LES Series

Step Motor (Servo/24 VDC)

Servo Motor (24 VDC)

Dimensions: Basic Type/R Type

LES8R

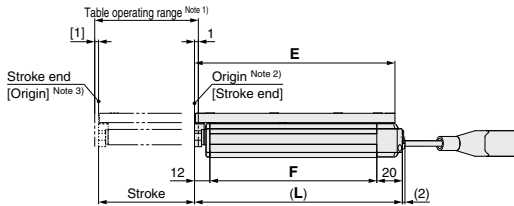
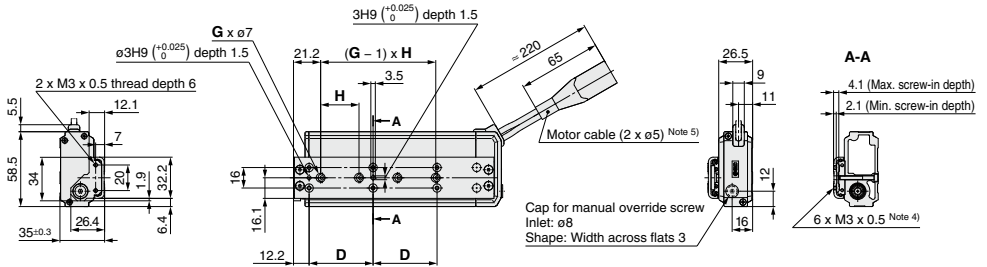

With lock

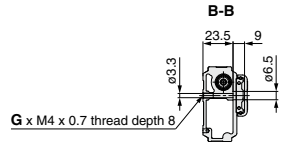
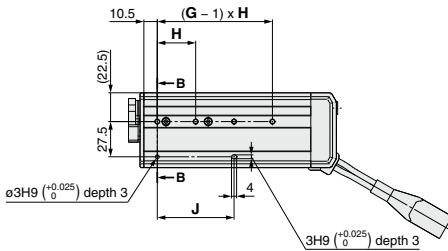
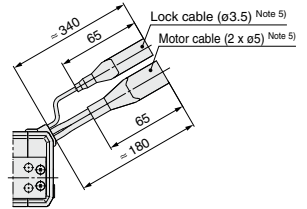

Note 1) Range within which the table can move when it returns to origin.

Make sure a workpiece mounted on the table does not interfere with the workpieces and facilities around the table.





Note 2) Position after return to origin.

Note 3) [] for when the direction of return to origin has changed.

Note 4) If workpiece retaining screws are too long, they can touch the guide block and cause a malfunction.

Use screws that are between the maximum and minimum screw-in depths in length.

Note 5) Secure the motor cable and lock cable so that the cables are not repeatedly bent.

	Connector	
	Step motor	Servo motor
Motor cable	 20 20	 24 24
Lock cable	 20 15	 20 15

Dimensions



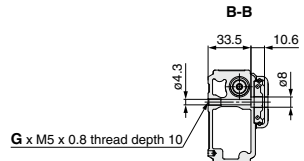
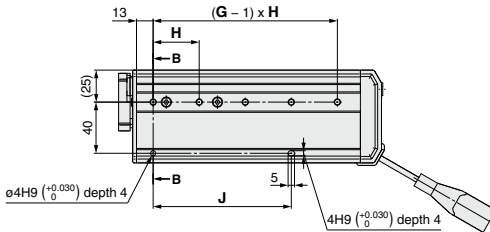
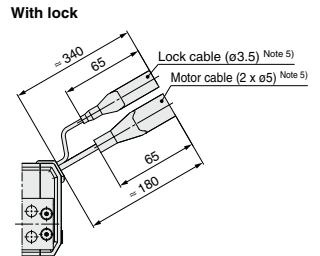
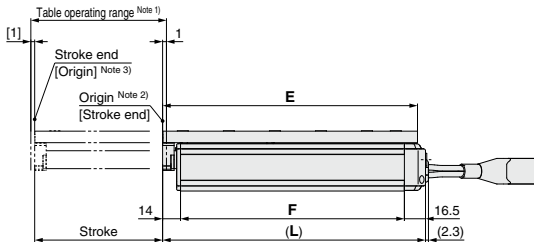
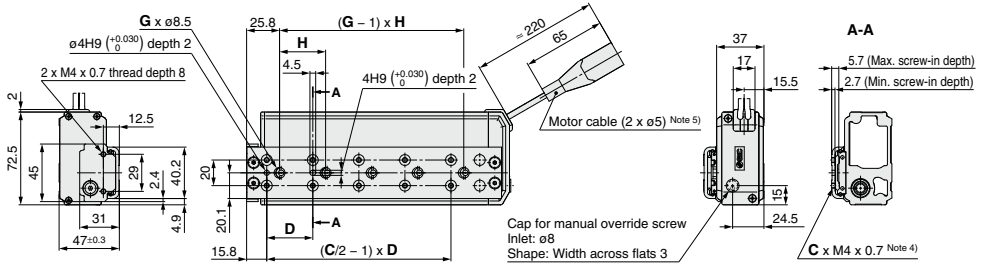

Model	L	D	E	F	G	H	J
LES8R□□-30□□□□□□	94.5	26	88.7	62.5	2	27	27
LES8R□□-50□□□□□□	137.5	46	131.7	105.5	3	29	58
LES8R□□-75□□□□□□	162.5	50	156.7	130.5	4	30	60

Dimensions: Basic Type/R Type

LES16R



- Note 1) Range within which the table can move when it returns to origin. Make sure a workpiece mounted on the table does not interfere with the workpieces and facilities around the table.
- Note 2) Position after return to origin.
- Note 3) [] for when the direction of return to origin has changed.
- Note 4) If workpiece retaining screws are too long, they can touch the guide block and cause a malfunction. Use screws that are between the maximum and minimum screw-in depths in length.
- Note 5) Secure the motor cable and lock cable so that the cables are not repeatedly bent.

	Connector	
	Step motor	Servo motor
Motor cable	 20	 24
Lock cable	 15	 15

Dimensions

[mm]

Model	L	C	D	E	F	G	H	J
LES16R□□-30□□□□□□	108.5	4	38	102.3	78	2	40	40
LES16R□□-50□□□□□□	136.5	6	34	130.3	106	2	78	78
LES16R□□-75□□□□□□	180.5	8	36	174.3	150	4	36	72
LES16R□□-100□□□□□□	205.5	10	36	199.3	175	5	36	108



LES Series

Step Motor (Servo/24 VDC)

Servo Motor (24 VDC)

Dimensions: Basic Type/R Type

LES25R

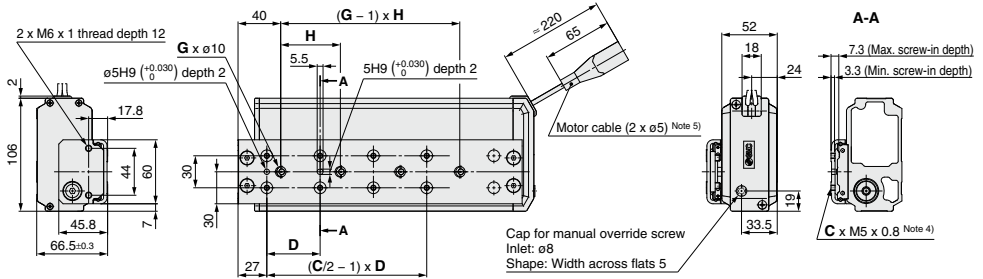

Cap for manual override screw
Inlet: ø8
Shape: Width across flats 5

With lock

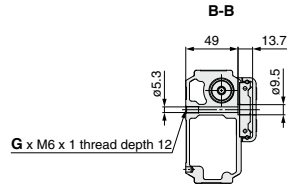
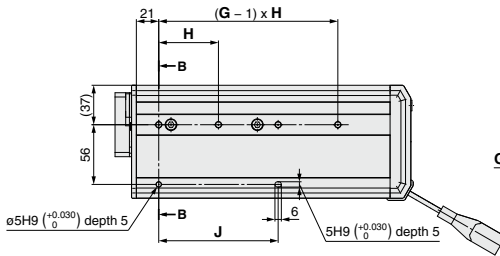
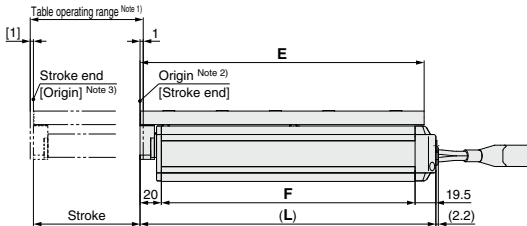
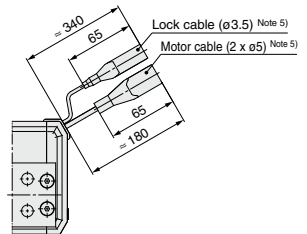

- Note 1) Range within which the table can move when it returns to origin.
Make sure a workpiece mounted on the table does not interfere with the workpieces and facilities around the table.
- Note 2) Position after return to origin.
- Note 3) [] for when the direction of return to origin has changed.
- Note 4) If workpiece retaining screws are too long, they can touch the guide block and cause a malfunction.
Use screws that are between the maximum and minimum screw-in depths in length.
- Note 5) Secure the motor cable and lock cable so that the cables are not repeatedly bent.

Dimensions

[mm]

Model	L	C	D	E	F	G	H	J
LES25R□□-30□□□□□□□□	144.5	4	48	133.5	105	2	46	46
LES25R□□-50□□□□□□□□	170.5	6	42	159.5	131	2	84	84
LES25R□□-75□□□□□□□□	204.5	6	55	193.5	165	2	112	112
LES25R□□-100□□□□□□□□	277.5	8	50	266.5	238	4	56	112
LES25R□□-125□□□□□□□□	302.5	8	55	291.5	263	4	59	118
LES25R□□-150□□□□□□□□	327.5	8	62	316.5	288	4	62	124

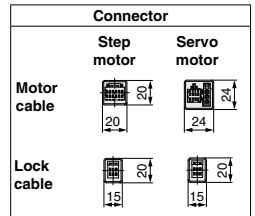

Dimensions: Symmetrical Type/L Type

LES8L

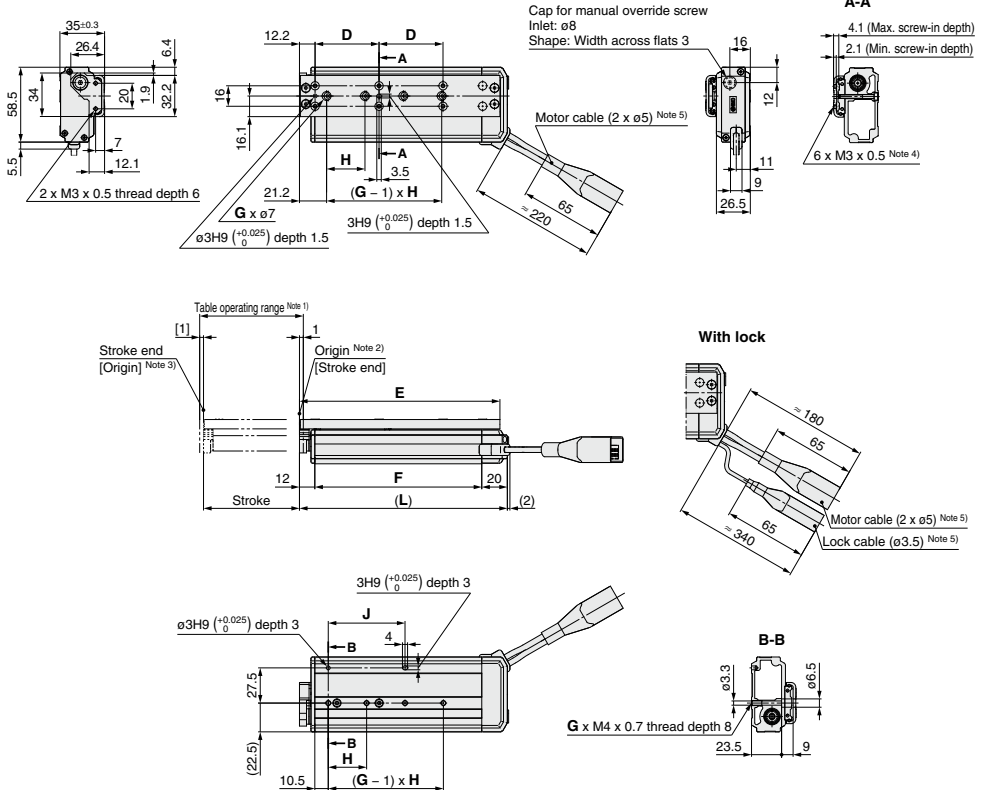

- Note 1) Range within which the table can move when it returns to origin.
 Make sure a workpiece mounted on the table does not interfere with the workpieces and facilities around the table.
- Note 2) Position after return to origin.
- Note 3) [] for when the direction of return to origin has changed.
- Note 4) If workpiece retaining screws are too long, they can touch the guide block and cause a malfunction.
 Use screws that are between the maximum and minimum screw-in depths in length.
- Note 5) Secure the motor cable and lock cable so that the cables are not repeatedly bent.

	Connector	
	Step motor	Servo motor
Motor cable		
Lock cable		

Dimensions	[mm]						
Model	L	D	E	F	G	H	J
LES8L□□-30□□□□□□□□	94.5	26	88.7	62.5	2	27	27
LES8L□□-50□□□□□□□□	137.5	46	131.7	105.5	3	29	58
LES8L□□-75□□□□□□□□	162.5	50	156.7	130.5	4	30	60



LES Series

Step Motor (Servo/24 VDC)

Servo Motor (24 VDC)

Dimensions: Symmetrical Type/L Type

LES16L

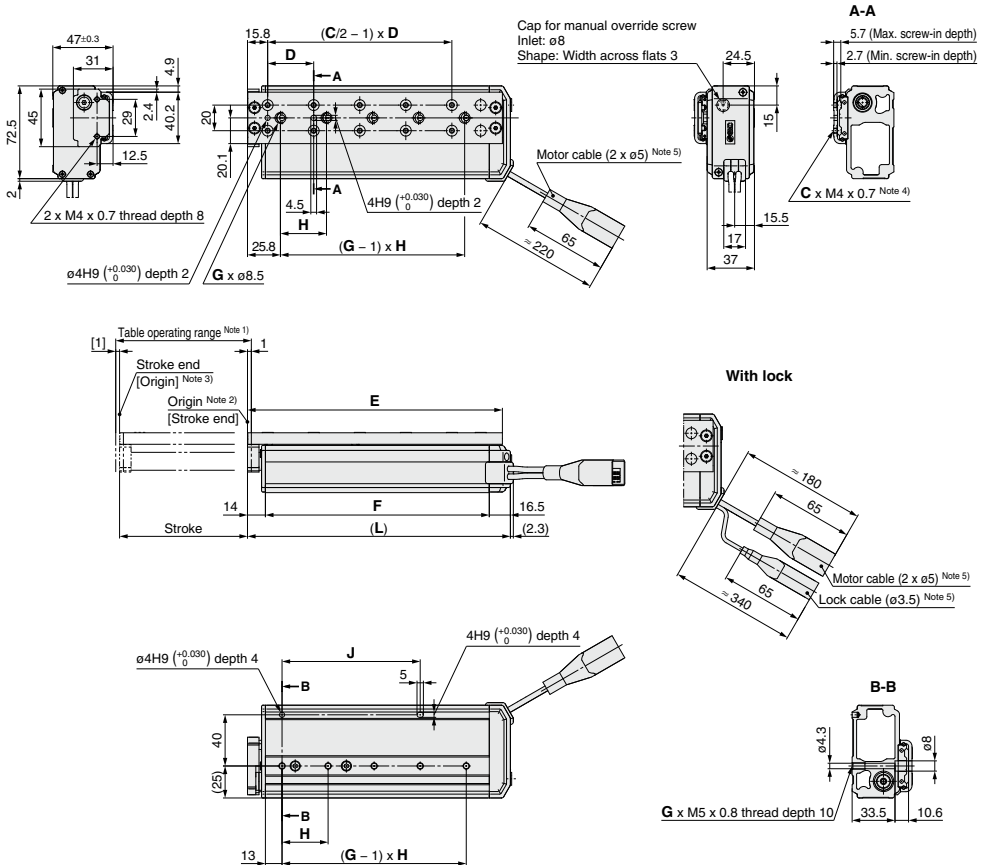

Note 1) Range within which the table can move when it returns to origin.

Make sure a workpiece mounted on the table does not interfere with the workpieces and facilities around the table.

Note 2) Position after return to origin.

Note 3) [] for when the direction of return to origin has changed.

Note 4) If workpiece retaining screws are too long, they can touch the guide block and cause a malfunction.

Use screws that are between the maximum and minimum screw-in depths in length.

Note 5) Secure the motor cable and lock cable so that the cables are not repeatedly bent.

	Connector	
	Step motor	Servo motor
Motor cable		
Lock cable		

Dimensions

[mm]

Model	L	C	D	E	F	G	H	J
LES16L□□-30□-□□□□	108.5	4	38	102.3	78	2	40	40
LES16L□□-50□-□□□□	136.5	6	34	130.3	106	2	78	78
LES16L□□-75□-□□□□	180.5	8	36	174.3	150	4	36	72
LES16L□□-100□-□□□□	205.5	10	36	199.3	175	5	36	108

Dimensions: Symmetrical Type/L Type

LES25L

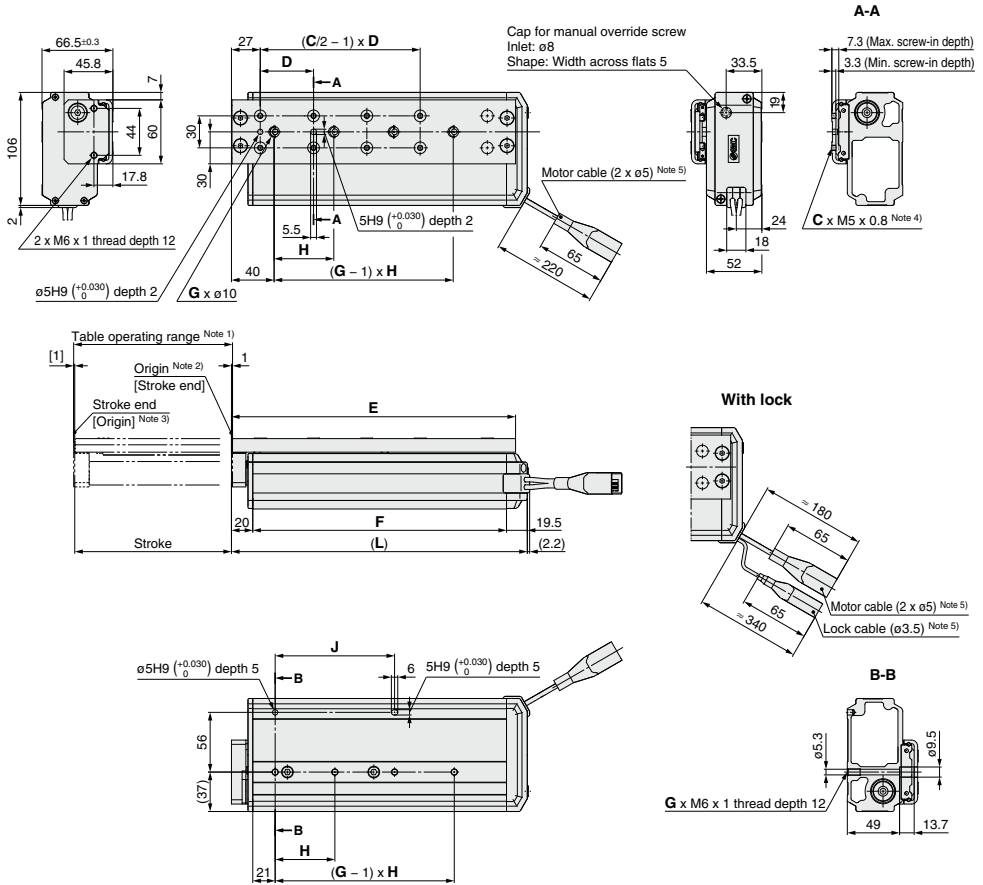

- Note 1) Range within which the table can move when it returns to origin.
 Make sure a workpiece mounted on the table does not interfere with the workpieces and facilities around the table.
- Note 2) Position after return to origin.
- Note 3) [] for when the direction of return to origin has changed.
- Note 4) If workpiece retaining screws are too long, they can touch the guide block and cause a malfunction.
 Use screws that are between the maximum and minimum screw-in depths in length.
- Note 5) Secure the motor cable and lock cable so that the cables are not repeatedly bent.

Dimensions

Model	L	C	D	E	F	G	H	J
LES25L□□-30□□□□□□□□	144.5	4	48	133.5	105	2	46	46
LES25L□□-50□□□□□□□□	170.5	6	42	159.5	131	2	84	84
LES25L□□-75□□□□□□□□	204.5	6	55	193.5	165	2	112	112
LES25L□□-100□□□□□□□□	277.5	8	50	266.5	238	4	56	112
LES25L□□-125□□□□□□□□	302.5	8	55	291.5	263	4	59	118
LES25L□□-150□□□□□□□□	327.5	8	62	316.5	288	4	62	124

	Connector	
	Step motor	Servo motor
Motor cable		
Lock cable		

LES Series

Step Motor (Servo/24 VDC)

Servo Motor (24 VDC)

Dimensions: In-line Motor Type/D Type

LES8D

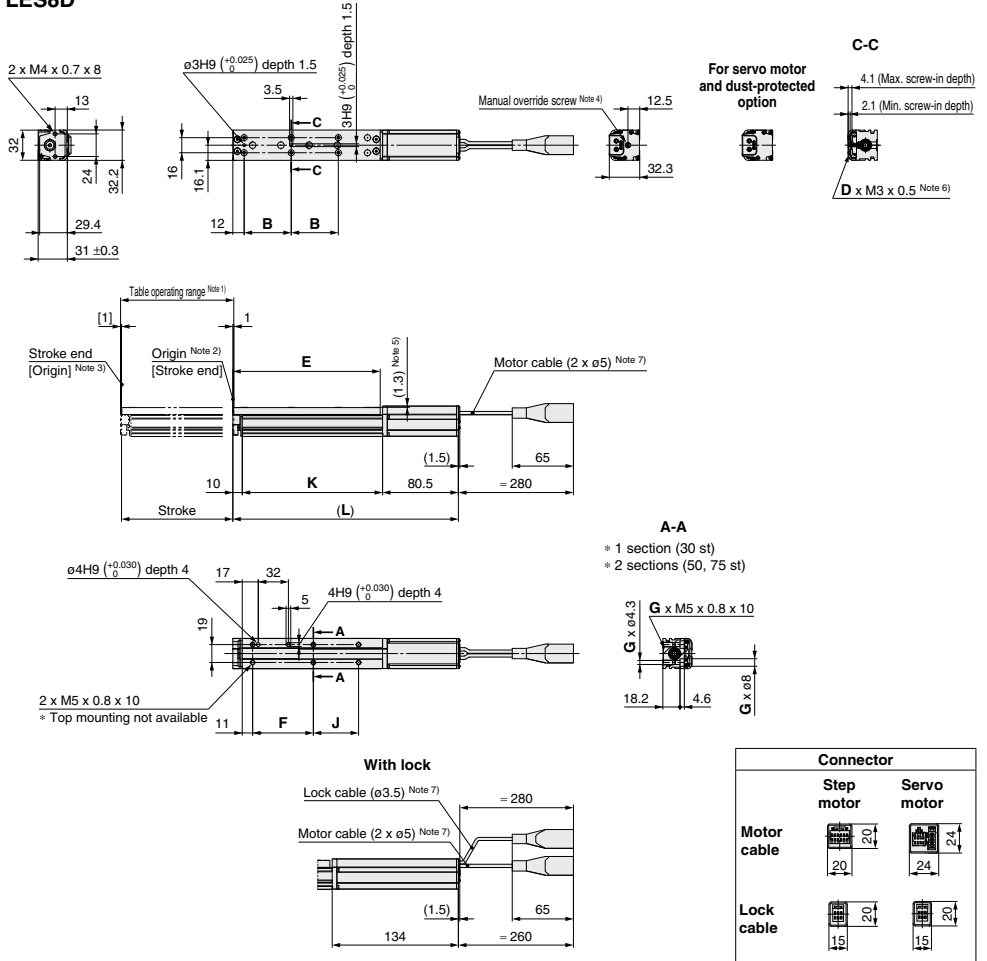

Note 1) Range within which the table can move when it returns to origin.

Make sure a workpiece mounted on the table does not interfere with the workpieces and facilities around the table.

Note 2) Position after return to origin.

Note 3) [] for when the direction of return to origin has changed.

Note 4) The distance between the motor end cover and the manual override screw is up to 16 mm. The motor end cover hole size is ø5.5.

Note 5) The table is lower than the motor cover. Make sure it does not interfere with the workpiece.

Note 6) If workpiece retaining screws are too long, they can touch the guide block and cause a malfunction.

Use screws that are between the maximum and minimum screw-in depths in length.

Note 7) Secure the motor cable and lock cable so that the cables are not repeatedly bent.

Dimensions

Model	(L)	B	D	E	F	G	J	K
LES8D□□-30□□-□□□□□□	171.5	26	6	88.5	44.5	2	—	81
LES8D□□-30B□□-□□□□□□	225							
LES8D□□-50□□-□□□□□□	214.5	46	6	131.5	64.5	4	23	124
LES8D□□-50B□□-□□□□□□	268							
LES8D□□-75□□-□□□□□□	239.5	50	6	156.5	64.5	4	48	149
LES8D□□-75B□□-□□□□□□	293							

Dimensions: In-line Motor Type/D Type

LES16D

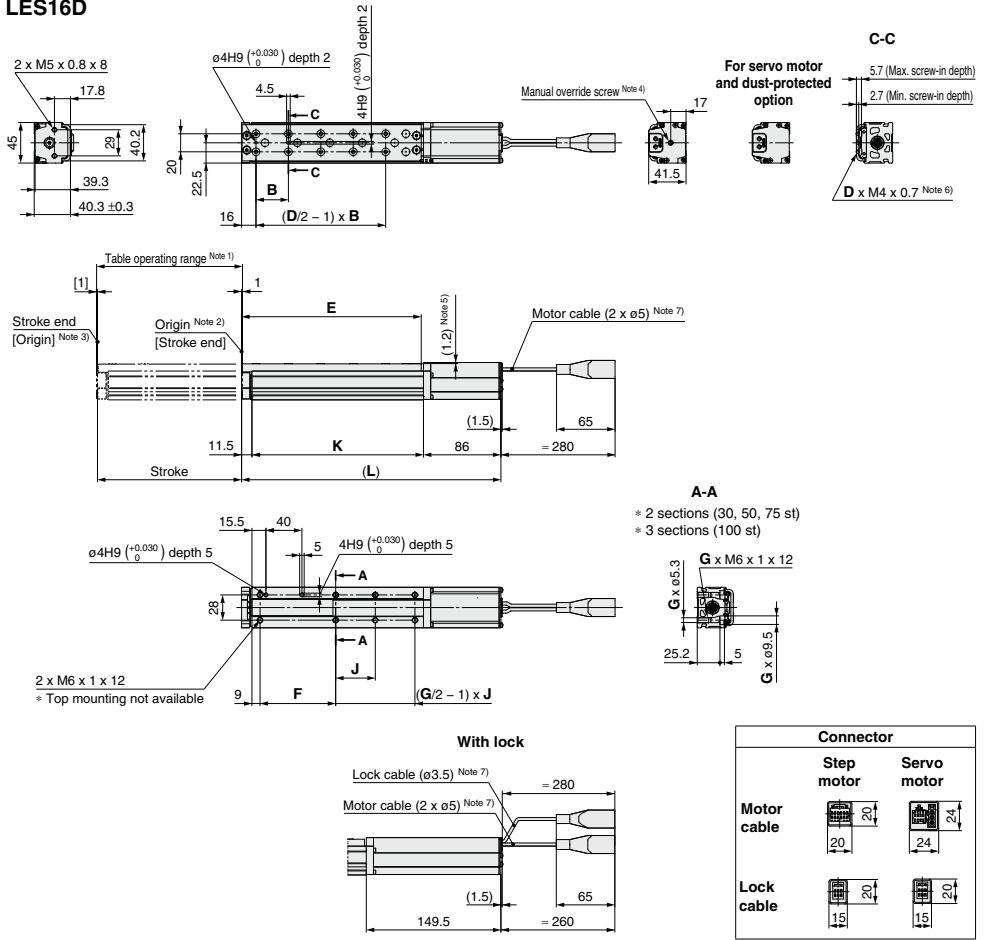

- Note 1) Range within which the table can move when it returns to origin.
Make sure a workpiece mounted on the table does not interfere with the workpieces and facilities around the table.
- Note 2) Position after return to origin.
- Note 3) [] for when the direction of return to origin has changed.
- Note 4) The distance between the motor end cover and the manual override screw is up to 17 mm. The motor end cover hole size is ø5.5.
- Note 5) The table is lower than the motor cover. Make sure it does not interfere with the workpiece.
- Note 6) If workpiece retaining screws are too long, they can touch the guide block and cause a malfunction.
- Note 7) Use screws that are between the maximum and minimum screw-in depths in length.
Secure the motor cable and lock cable so that the cables are not repeatedly bent.

Dimensions

Model	(L)	B	D	E	F	G	J	K
LES16D□□-30□□-□□□□	193	38	4	102.5	56.5	4	18.5	95.5
LES16D□□-30B□□-□□□□	256.5							
LES16D□□-50□□-□□□□	221	34	6	130.5	65	4	38	123.5
LES16D□□-50B□□-□□□□	284.5							
LES16D□□-75□□-□□□□	265	36	8	174.5	84	4	63	167.5
LES16D□□-75B□□-□□□□	328.5							
LES16D□□-100□□-□□□□	290	36	10	199.5	84	6	44	192.5
LES16D□□-100B□□-□□□□	353.5							

Dimensions: In-line Motor Type/D Type

LES25D

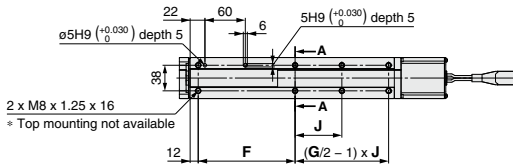
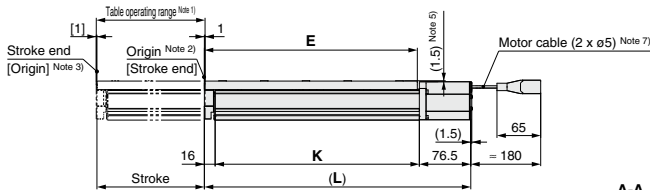
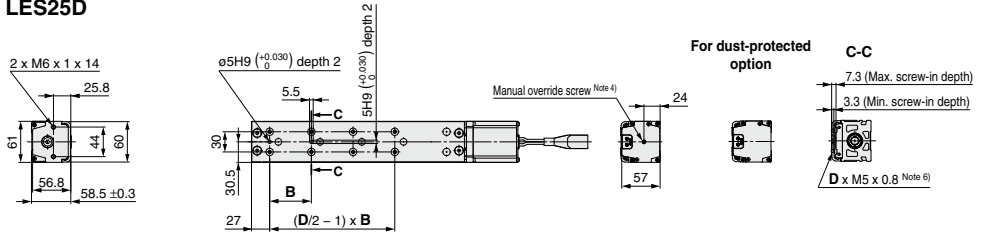

A-A
 * 2 sections (30, 50, 75, 100 st)
 * 3 sections (125, 150 st)

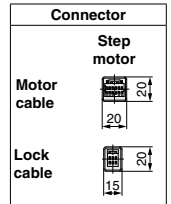
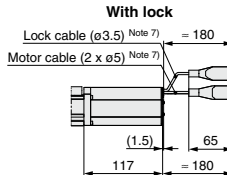
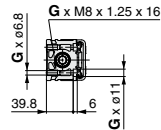

Note 1) Range within which the table can move when it returns to origin. Make sure a workpiece mounted on the table does not interfere with the workpieces and facilities around the table.

Note 2) Position after return to origin.

Note 3) [] for when the direction of return to origin has changed.

Note 4) The distance between the motor end cover and the manual override screw is up to 4 mm. The motor end cover hole size is ø5.5.

Note 5) The table is lower than the motor cover.

Note 6) If workpiece retaining screws are too long, they can touch the guide block and cause a malfunction. Use screws that are between the maximum and minimum screw-in depths in length.

Note 7) Secure the motor cable and lock cable so that the cables are not repeatedly bent.

Dimensions

Model	(L)	B	D	E	F	G	J	K
LES25D□-30□□□□□□□□	214							
LES25D□-30B□□□□□□□□	254.5	48	4	133.5	81	4	19	121.5
LES25D□-50□□□□□□□□	240							
LES25D□-50B□□□□□□□□	280.5	42	6	159.5	87	4	39	147.5
LES25D□-75□□□□□□□□	274							
LES25D□-75B□□□□□□□□	314.5	55	6	193.5	96	4	64	181.5
LES25D□-100□□□□□□□□	347							
LES25D□-100B□□□□□□□□	387.5	50	8	266.5	144	4	89	254.5
LES25D□-125□□□□□□□□	372							
LES25D□-125B□□□□□□□□	412.5	55	8	291.5	144	6	57	279.5
LES25D□-150□□□□□□□□	397							
LES25D□-150B□□□□□□□□	437.5	62	8	316.5	144	6	69.5	304.5

Side Holder (In-line Motor Type/D Type)

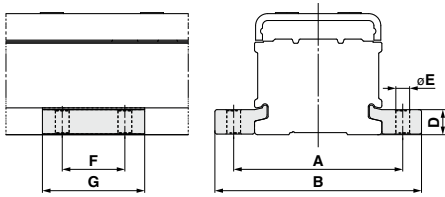

Part no. (Note)	A	B	D	E	F	G	Applicable model
LE-D-3-1	45	57.6	6.7	4.5	20	33	LES8D
LE-D-3-2	60	74	8.3	5.5	25	40	LES16D
LE-D-3-3	81	99	12	6.6	30	49	LES25D

Note) Model numbers for 1 side holder.

Model Selection 1



LESH Series ▶ Pages 350, 351-1

Selection Procedure For the compact type LES series, refer to page 314.

- Step 1** Check the work load-speed. → **Step 2** Check the cycle time. → **Step 3** Check the allowable moment.

Selection Example

Step 1 Check the work load-speed. <Speed-Work load graph> (Page 341)

Select the target model based on the workpiece mass and speed with reference to the <Speed-Work load graph>. Selection example) The LESH16□J-50 is temporarily selected based on the graph shown on the right side.

Step 2 Check the cycle time.

It is possible to obtain an approximate cycle time by using method 1, but if a more detailed cycle time is required, use method 2.

* Although it is possible to make a suitable selection by using method 1, this calculation is based on a maximum load condition. Therefore, if a more detailed selection for each load is required, use method 2.

Operating conditions

- Workpiece mass: 1 [kg]
- Workpiece mounting condition:
- Speed: 220 [mm/s]
- Mounting orientation: Vertical
- Stroke: 50 [mm]
- Acceleration/Deceleration: 5000 [mm/s²]
- Cycle time: 0.5 seconds

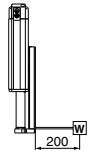

Method 1: Check the cycle time graph. (Page 342)

Method 2: Calculation <Speed-Work load graph> (Page 341)

Calculate the cycle time using the following calculation method.

Calculation example
T1 to T4 can be calculated as follows.

Cycle time:

T can be found from the following equation.

$$T = T1 + T2 + T3 + T4 \text{ [s]}$$

- T1: Acceleration time and T3: Deceleration time can be obtained by the following equation.

$$T1 = V/a1 \text{ [s]} \quad T3 = V/a2 \text{ [s]}$$

- T2: Constant speed time can be found from the following equation.

$$T2 = \frac{L - 0.5 \cdot V \cdot (T1 + T3)}{V} \text{ [s]}$$

- T4: Settling time varies depending on the conditions such as motor types, load and in position of the step data. Therefore, calculate the settling time with reference to the following value.

$$T4 = 0.15 \text{ [s]}$$

$$T1 = V/a1 = 220/5000 = 0.04 \text{ [s]}$$

$$T3 = V/a2 = 220/5000 = 0.04 \text{ [s]}$$

$$T2 = \frac{L - 0.5 \cdot V \cdot (T1 + T3)}{V} = \frac{50 - 0.5 \cdot 220 \cdot (0.04 + 0.04)}{220} = 0.19 \text{ [s]}$$

$$T4 = 0.15 \text{ [s]}$$

Therefore, the cycle time can be obtained as follows.

$$T = T1 + T2 + T3 + T4 = 0.04 + 0.19 + 0.04 + 0.15 = 0.42 \text{ [s]}$$

LESH16□/Step Motor Vertical

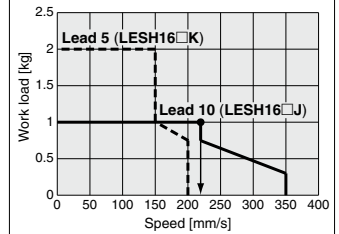

<Speed-Work load graph>

LESH16□/Step Motor

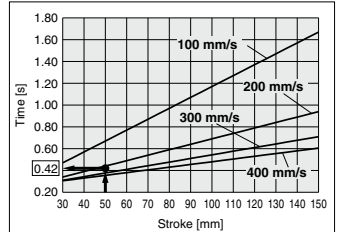

<Cycle time>

Step 3 Check the allowable moment. <Static allowable moment> (Page 342)

<Dynamic allowable moment> (Pages 343, 344)

Confirm the moment that applies to the actuator is within the allowable range for both static and dynamic conditions.

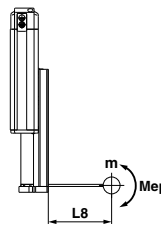

LESH16□/Pitching

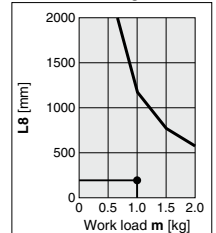

<Dynamic allowable moment>

Based on the above calculation result, the LESH16□J-50 is selected.

Speed-Work Load Graph (Guide)

Step Motor (Servo/24 VDC)

* The following graph shows the values when moving force is 100%.

LESH8□

Horizontal

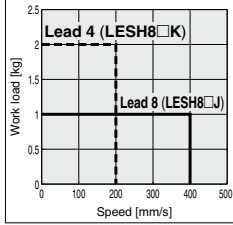

Vertical

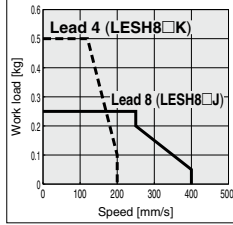

LESH16□

Horizontal

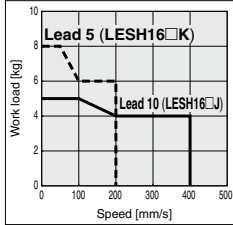

Vertical

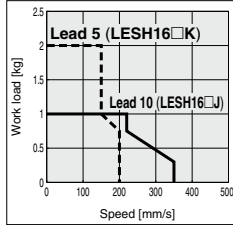

LESH25□

Horizontal

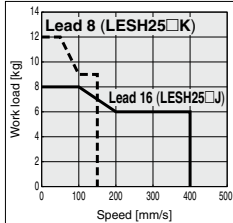

Vertical

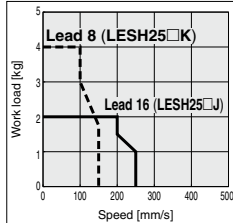

Servo Motor (24 VDC)

* The following graph shows the values when moving force is 250%.

LESH8□A

Horizontal

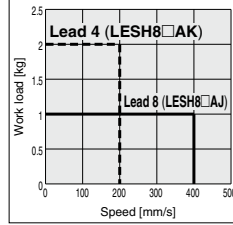

Vertical

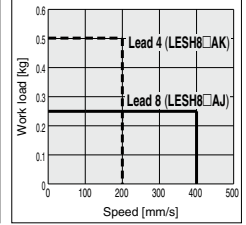

LESH16□A

Horizontal

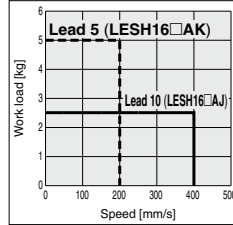

Vertical

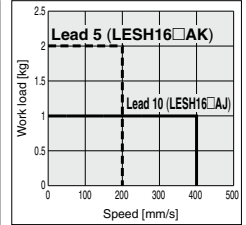

LESH25^RLA

Horizontal

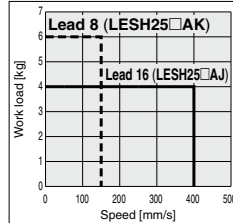

Vertical

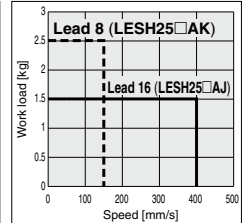

LESH Series

Step Motor (Servo/24 VDC)

Servo Motor (24 VDC)

Cycle Time (Guide)

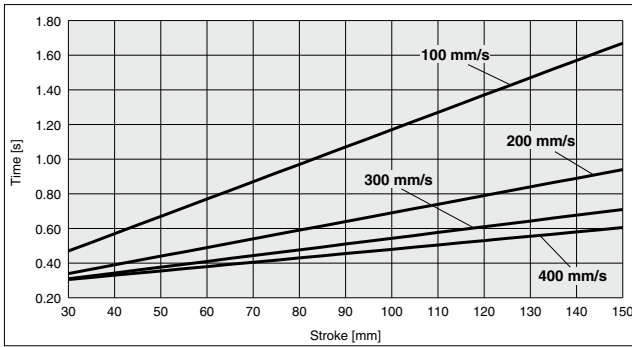

Operating Conditions

Acceleration/Deceleration: 5000 mm/s²

In position: 0.5 mm

Static Allowable Moment

Model		LESH8		LESH16		LESH25		
Stroke	[mm]	50	75	50	100	50	100	150
Pitching	[N·m]	11		26	43	77	112	155
Yawing	[N·m]	11						
Rolling	[N·m]	12		48		146	177	152

* This graph shows the amount of allowable overhang (guide unit) when the center of gravity of the workpiece overhangs in one direction. When selecting the overhang, refer to "Calculation of Guide Load Factor" or the Electric Actuator Selection Software for confirmation, <http://www.smcworld.com>

Dynamic Allowable Moment

Acceleration/Deceleration — 5000 mm/s²

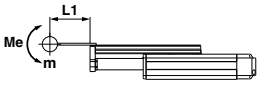
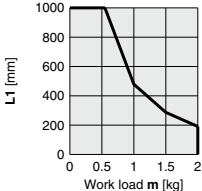
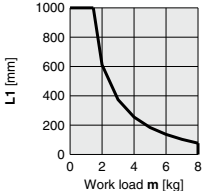
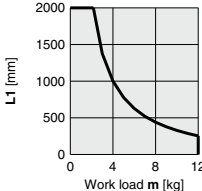
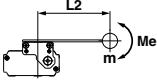
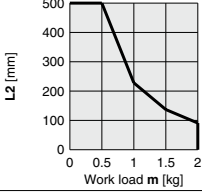
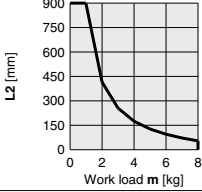
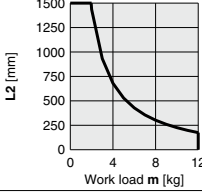
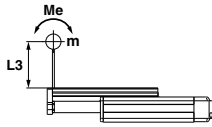
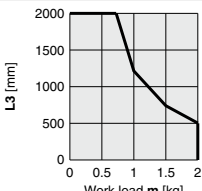
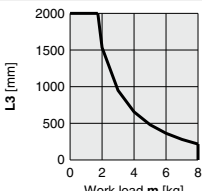
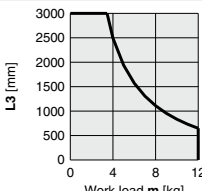
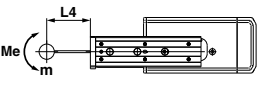
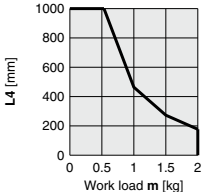
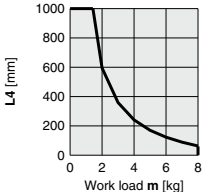
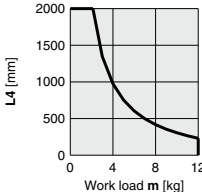
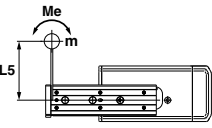
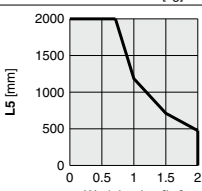
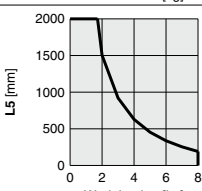
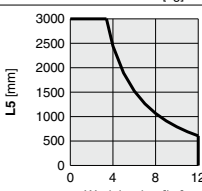
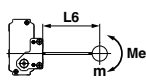
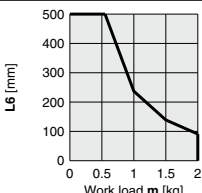
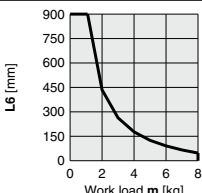
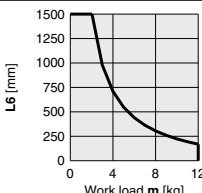
Orientation	Load overhanging direction m : Work load [kg] Me: Dynamic allowable moment [N·m] L : Overhang to the work load center of gravity [mm]	Model		
		LESH8	LESH16	LESH25
Horizontal/Bottom	X 			
	Y 			
	Z 			
Horizontal (Wall)	X 			
	Y 			
	Z 			

* This graph shows the amount of allowable overhang (guide unit) when the center of gravity of the workpiece overhangs in one direction. When selecting the overhang, refer to "Calculation of Guide Load Factor" or the Electric Actuator Selection Software for confirmation, <http://www.smcworld.com>

Dynamic Allowable Moment

Acceleration/Deceleration — 5000 mm/s²

Orientation	Load overhanging direction m : Work load [kg] Me: Dynamic allowable moment [N·m] L : Overhang to the work load center of gravity [mm]	Model		
		LESH8	LESH16	LESH25
Vertical				

Calculation of Guide Load Factor

- Decide operating conditions.

Model: LESH
Size: 8/16/25
Mounting orientation: Horizontal/Bottom/Wall/Vertical

Acceleration [mm/s²]: a
Work load [kg]: m
Work load center position [mm]: Xc/Yc/Zc

- Select the target graph with reference to the model, size and mounting orientation.

- Based on the acceleration and work load, obtain the overhang [mm]: Lx/Ly/Lz from the graph.

- Calculate the load factor for each direction.

$$\alpha x = Xc/Lx, \alpha y = Yc/Ly, \alpha z = Zc/Lz$$

- Confirm the total of αx , αy and αz is 1 or less.

$$\alpha x + \alpha y + \alpha z \leq 1$$

When 1 is exceeded, please consider a reduction of acceleration and work load, or a change of the work load center position and series.

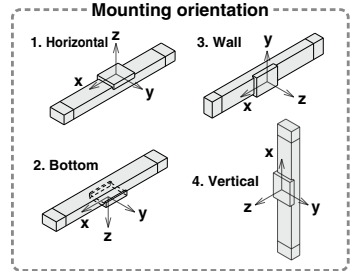

Example

- Operating conditions

Model: LESH
Size: 8
Mounting orientation: Horizontal
Acceleration [mm/s²]: 5000
Work load [kg]: 1.0
Work load center position [mm]: Xc = 80, Yc = 100, Zc = 60

- Select three graphs from the top of the left side first row on page 343.

- Lx = 480 mm, Ly = 225 mm, Lz = 1200 mm

- The load factor for each direction can be obtained as follows.

$$\alpha x = 80/480 = 0.17$$

$$\alpha y = 100/225 = 0.44$$

$$\alpha z = 60/1200 = 0.05$$

- $\alpha x + \alpha y + \alpha z = 0.66 \leq 1$

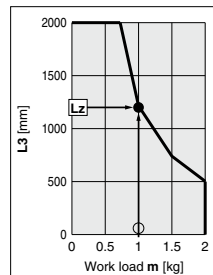
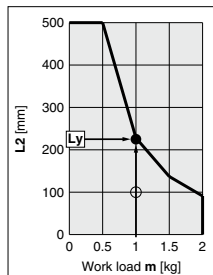
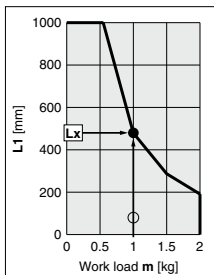

Electric Slide Table/High Rigidity Type
LESH Series

Model Selection 2



LESH Series ▶ Pages 350, 351-1

Selection Procedure

For the compact type LES series, refer to page 320.

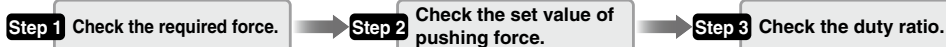

Selection Example

Operating conditions

- Pushing force: 90 [N]
- Workpiece mass: 1 [kg]
- Speed: 100 [mm/s]
- Stroke: 100 [mm]
- Mounting orientation: Vertical upward
- Pushing time + Operation (A): 1.5 seconds
- All cycle time (B): 6 seconds

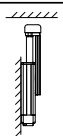

Step 1 Check the required force.

Calculate the approximate required force for pushing operation.
Selection example) • Pushing force: 90 [N]

- Workpiece mass: 1 [kg]
- Therefore, the approximate required force can be obtained as $90 + 10 = 100$ [N].

Select the target model based on the approximate required force with reference to the specifications (Pages 352 and 353).
Selection example) Based on the specifications,

- Approximate required force: 100 [N]
 - Speed: 100 [mm/s]
- Therefore, the LESH25□ is temporarily selected.

Then, calculate the required force for pushing operation.
If the mounting position is vertical upward, add the actuator table weight.

- Selection example) Based on the <Table weight>,
• LESH25□ table weight: 1.3 [kg]
- Therefore, the required force can be obtained as $100 + 13 = 113$ [N].

Step 2 Check the set value of pushing force.

<Set value of pushing force–Force graph> (Page 347)
Select the target model based on the required force with reference to the <Set value of pushing force–Force graph>, and confirm the set value of pushing force.
Selection example) Based on the graph shown on the right side,

- Required force: 113 [N]
- Therefore, the LESH25□K is temporarily selected.
This set value of pushing force is 40 [%].

Step 3 Check the duty ratio.

Confirm the allowable duty ratio based on the set value of pushing force with reference to the <Allowable duty ratio>.
Selection example) Based on the <Allowable duty ratio>,
• Set value of pushing force: 40 [%]

Therefore, the allowable duty ratio can be obtained as 30 [%].

Calculate the duty ratio for operating conditions, and confirm it does not exceed the allowable duty ratio.

- Selection example) • Pushing time + Operation (A): 1.5 seconds
- All cycle time (B): 6 seconds
- Therefore, the duty ratio can be obtained as $1.5/6 \times 100 = 25$ [%], and this is the allowable range.

Based on the above calculation result, the LESH25□K-100 is selected.

For allowable moment, the selection procedure is the same as the positioning control.

Table Weight

[kg]

Model	Stroke [mm]			
	50	75	100	150
LESH8	0.2	0.3	—	—
LESH16	0.4	—	0.7	—
LESH25	0.9	—	1.3	1.7

* If the mounting position is vertical upward, add the table weight.

LESH25□/Step Motor

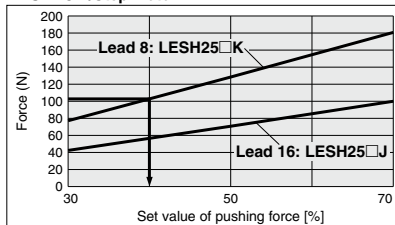

<Set value of pushing force–Force graph>

Allowable Duty Ratio

Step Motor (Servo/24 VDC)

Set value of pushing force (%)	Duty ratio (%)	Continuous pushing time (minute)
30	—	—
50 or less	30 or less	5 or less
70 or less	20 or less	3 or less

Servo Motor (24 VDC)

Set value of pushing force (%)	Duty ratio (%)	Continuous pushing time (minute)
50	—	—
75 or less	30 or less	5 or less
100 or less	20 or less	3 or less

* The pushing force of the LESH8□A is up to 75%.

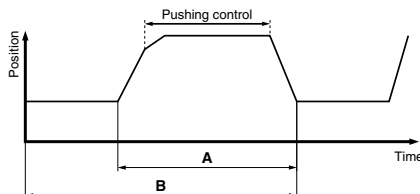

Set Value of Pushing Force–Force Graph

Step Motor (Servo/24 VDC)

LESH8□

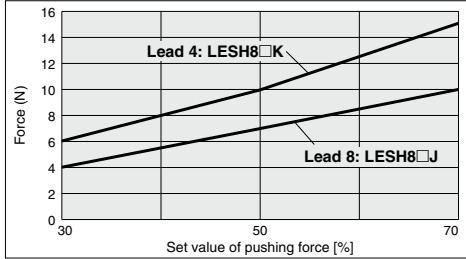

LESH16□

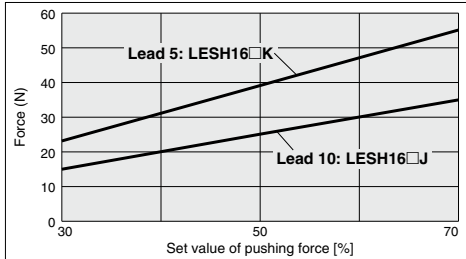

LESH25□

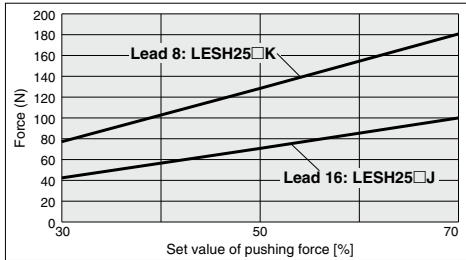

Servo Motor (24 VDC)

LESH8□A

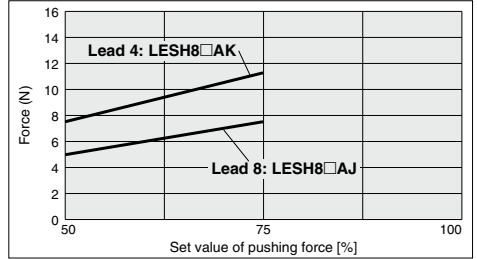

LESH16□A

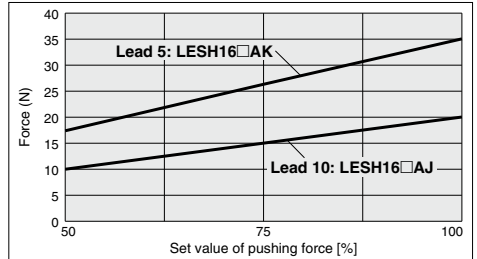

LESH25^R□A

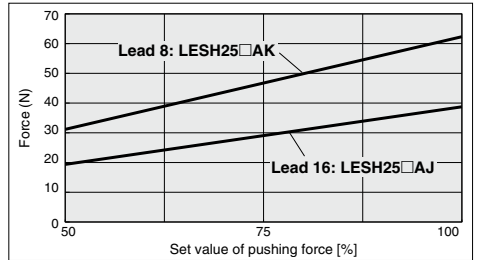

LESH Series

Step Motor (Servo/24 VDC)

Servo Motor (24 VDC)

Table Accuracy

* These values are initial guideline values.

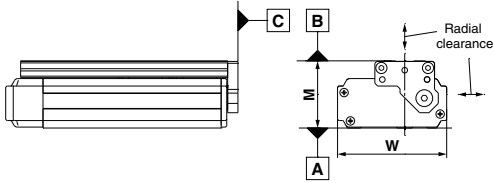

Model	LESH8	LESH16	LESH25
B side parallelism to A side [mm]	Refer to Table 1.		
B side traveling parallelism to A side [mm]	Refer to Graph 1.		
C side perpendicularity to A side [mm]	0.05	0.05	0.05
M dimension tolerance [mm]	±0.3		
W dimension tolerance [mm]	±0.2		
Radial clearance [μm]	-4 to 0	-10 to 0	-14 to 0

Table 1 B side parallelism to A side

Model	Stroke [mm]			
	50	75	100	150
LESH8	0.055	0.065	—	—
LESH16	0.05	—	0.08	—
LESH25	0.06	—	0.08	0.125

Graph 1 B side traveling parallelism to A side

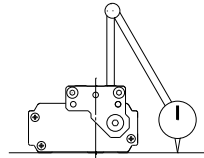
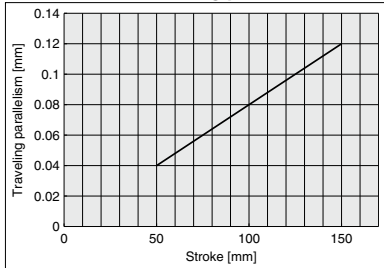

Traveling parallelism:
The amount of deflection on a dial gauge when the table travels a full stroke with the body secured on a reference base surface

Table Deflection (Reference Value)

* These values are initial guideline values.

Table displacement due to pitch moment load
 Table displacement when loads are applied to the section marked with the arrow with the slide table stuck out.



Table displacement due to yaw moment load
 Table displacement when loads are applied to the section marked with the arrow with the slide table stuck out.

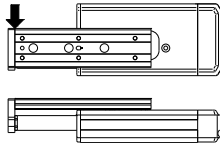
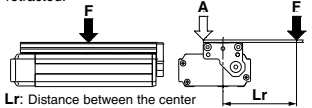
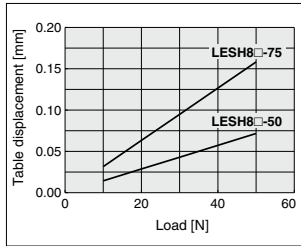

Table displacement due to roll moment load
 Table displacement of section A when loads are applied to the section F with the slide table retracted.



Lr: Distance between the center of the table and the work load center of gravity

LESH8



LESH8

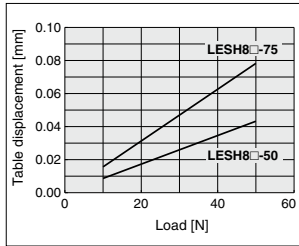

LESH8

Lr = 70 mm

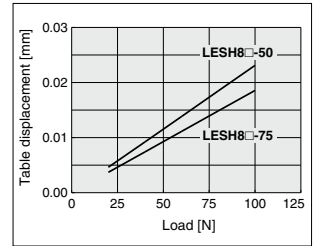

LESH16

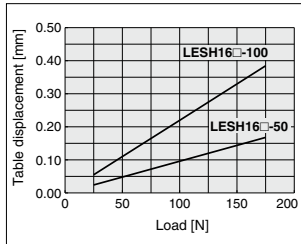

LESH16

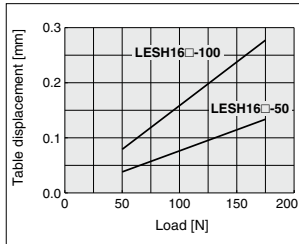

LESH16

Lr = 120 mm

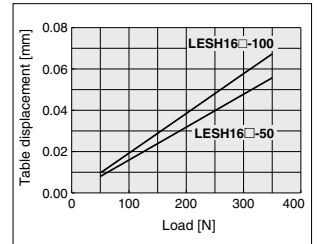

LESH25

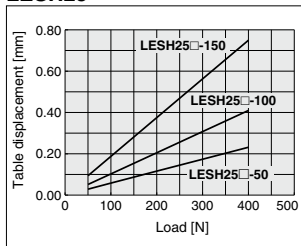

LESH25

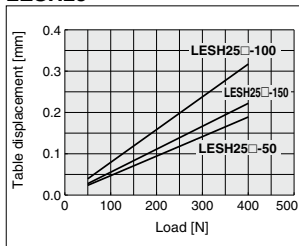

LESH25

Lr = 200 mm

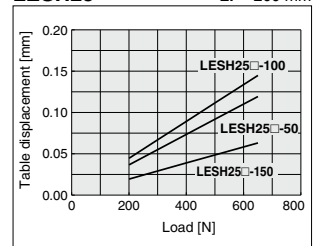

Electric Slide Table/ High Rigidity Type

LESH Series LESH8, 16, 25

Applicable to the
LEC□ series



Refer to page 351-1 for the communication protocols EtherCAT®, EtherNet/IP™, PROFINET, DeviceNet™, and IO-Link.

How to Order

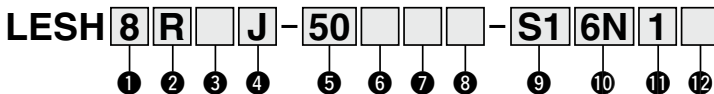

① Size

8
16
25

② Motor mounting position

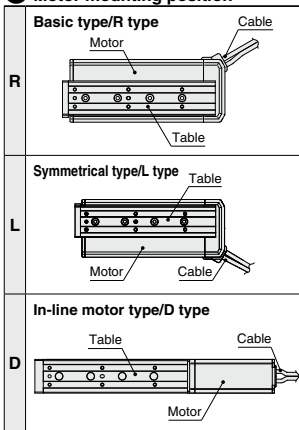

③ Motor type

Symbol	Type	Compatible controller/driver
Nil	Step motor (Servo/24 VDC)	LECP6 LECP1 LECPA LECPMJ
A	Servo motor* (24 VDC)	LECA6

* LESH25DA is not available.

⚠ Caution

[CE-compliant products]

① EMC compliance was tested by combining the electric actuator LES series and the controller LEC series.

The EMC depends on the configuration of the customer's control panel and the relationship with other electrical equipment and wiring. Therefore, conformity to the EMC directive cannot be certified for SMC components incorporated into the customer's equipment under actual operating conditions. As a result, it is necessary for the customer to verify conformity to the EMC directive for the machinery and equipment as a whole.

② For the servo motor (24 VDC) specification, EMC compliance was tested by installing a noise filter set (LEC-NFA).

Refer to page 568 for the noise filter set. Refer to the LECA Operation Manual for installation.

③ CC-Link direct input type (LECPMJ) is not CE-compliant.

[UL-compliant products]

When conformity to UL is required, the electric actuator and controller/driver should be used with a UL1310 Class 2 power supply.

④ Lead [mm]

Symbol	LESH8	LESH16	LESH25
J	8	10	16
K	4	5	8

⑤ Stroke [mm]

Model	Stroke			
	50	75	100	150
LESH8	●*	●	—	—
LESH16	●*	—	●	—
LESH25	●	—	●	●

* R/L type with lock is not available.

⑥ Motor option

Nil	Without option
B	With lock

⑦ Body option

Nil	Without option
S	Dust-protected*

* For R/L type (IP5X equivalent), a scraper is mounted on the rod cover, and gaskets are mounted on both the end covers. For D type, a scraper is mounted on the rod cover.

The actuator and controller/driver are sold as a package.

Confirm that the combination of the controller/driver and the actuator is correct.

<Check the following before use.>

- Check the actuator label for model number. This matches the controller/driver.
- Check Parallel I/O configuration matches (NPN or PNP).

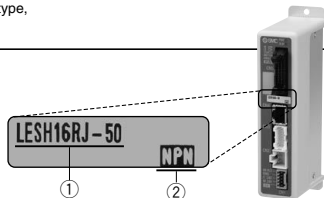

* Refer to the operation manual for using the products. Please download it via our website, <http://www.smcworld.com>

Electric Slide Table/High Rigidity Type **LESH Series**

Step Motor (Servo/24 VDC) Servo Motor (24 VDC)



Basic type (R type)



Symmetrical type (L type)



In-line motor type (D type)

8 Mounting*

Symbol	Mounting	R type L type	D type
Nil	Without side holder	●	●
H	With side holder (4 pcs.)	—	●

* Refer to page 365 for details.

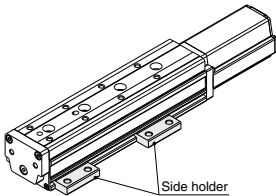

Side holder

9 Actuator cable type/length*2

Symbol	Without cable
S1	Standard cable 1.5 m*3
S3	Standard cable 3 m*3
S5	Standard cable 5 m*3
R1	Robotic cable 1.5 m
R3	Robotic cable 3 m
R5	Robotic cable 5 m
R8	Robotic cable 8 m*1
RA	Robotic cable 10 m*1
RB	Robotic cable 15 m*1
RC	Robotic cable 20 m*1

*1 Produced upon receipt of order (Robotic cable only)

*2 The standard cable should only be used on fixed parts.

For use on moving parts, select the robotic cable.

*3 Only available for the motor type "Step motor."

10 Controller/Driver type*1

Symbol	Without controller/driver	
6N	LECP6/LECA6 (Step data input type)	NPN
6P		PNP
1N	LECP1 *2 (Programless type)	NPN
1P		PNP
MJ	LECPMJ *2 *3 (CC-Link direct input type)	—
AN		NPN
AP	LECPA *2 *4 (Pulse input type)	NPN
		PNP

*1 For details about controller/driver and compatible motor, refer to the compatible controller/driver below.

*2 Only available for the motor type "Step motor."

*3 Not applicable to CE.

*4 When pulse signals are open collector, order the current limiting resistor (LEC-PA-R-□) on page 596 separately.

11 I/O cable length*1, Communication plug

Symbol	Without cable (Without communication plug connector)*3
1	1.5 m
3	3 m*2
5	5 m*2
S	Straight type communication plug connector*3
T	T-branch type communication plug connector*3

*1 When "Without controller/driver" is selected for controller/driver types, I/O cable cannot be selected. Refer to page 568 (For LECP6/LECA6), page 582 (For LECP1) or page 596 (For LECPA) if I/O cable is required.

*2 When "Pulse input type" is selected for controller/driver types, pulse input usable only with differential. Only 1.5 m cables usable with open collector.

*3 For the LECPMJ, only "Nil", "S" and "T" are selectable since I/O cable is not included.

12 Controller/Driver mounting

Symbol	Mounting
Nil	Screw mounting
D	DIN rail mounting*

* DIN rail is not included. Order it separately.

Compatible Controller/Driver

Type	Step data input type	Step data input type	CC-Link direct input type	Programless type	Pulse input type
Series	LECP6	LECA6	LECPMJ	LECP1	LECPA
Features	Value (Step data) input Standard controller		CC-Link direct input	Capable of setting up operation (step data) without using a PC or teaching box	Operation by pulse signals
Compatible motor	Step motor (Servo/24 VDC)	Servo motor (24 VDC)		Step motor (Servo/24 VDC)	
Maximum number of step data	64 points			14 points	—
Power supply voltage	24 VDC				
Reference page	Page 560	Page 560	Page 600	Page 576	Page 590

Electric Slide Table/ High Rigidity Type

LESH Series LESH8, 16, 25



Applicable to the
JXC□ series

How to Order

Refer to page 350 for the communication protocol CC-Link.

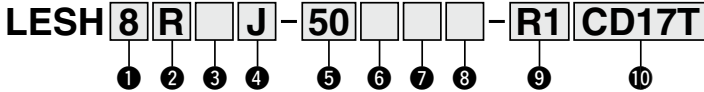

1 Size

8
16
25

2 Motor mounting position

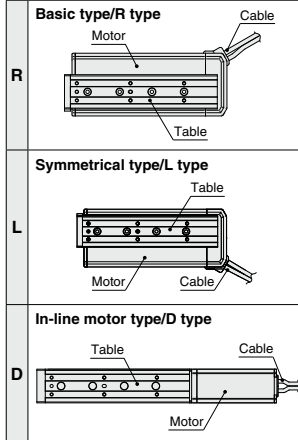

3 Motor type

Symbol	Type	Compatible controller
Nil	Step Motor (Servo/24 VDC)	JXCE1 JXC91 JXCP1 JXCD1 JXCL1

⚠ Caution

[CE-compliant products]

EMC compliance was tested by combining the electric actuator LE series and the JXCE1/91/P1/D1/L1 series.

The EMC depends on the configuration of the customer's control panel and the relationship with other electrical equipment and wiring. Therefore, conformity to the EMC directive cannot be certified for SMC components incorporated into the customer's equipment under actual operating conditions. As a result, it is necessary for the customer to verify conformity to the EMC directive for the machinery and equipment as a whole.

4 Lead [mm]

Symbol	LESH8	LESH16	LESH25
J	8	10	16
K	4	5	8

5 Stroke [mm]

Model	Stroke			
	50	75	100	150
LESH8	●*	●	—	—
LESH16	●*	—	●	—
LESH25	●	—	●	●

* R/L type with lock is not available.

6 Motor option

Nil	Without option
B	With lock

7 Body option

Nil	Without option
S	Dust-protected*

* For R/L type (IP5X equivalent), a scraper is mounted on the rod cover, and gaskets are mounted on both the end covers. For D type, a scraper is mounted on the rod cover.

Electric Slide Table/High Rigidity Type **LESH Series**

Step Motor (Servo/24 VDC) Servo Motor (24 VDC)



Basic type (R type)



Symmetrical type (L type)



In-line motor type (D type)

8 Mounting*

Symbol	Mounting	R type L type	D type
Nil	Without side holder	●	●
H	With side holder (4 pcs.)	—	●

* Refer to page 365 for details.

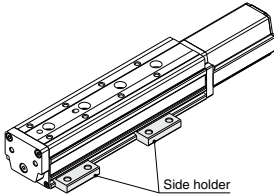

Side holder

9 Actuator cable type/length

Nil	Without cable
S1	Standard cable 1.5 m
S3	Standard cable 3 m
S5	Standard cable 5 m
R1	Robotic cable 1.5 m
R3	Robotic cable 3 m
R5	Robotic cable 5 m
R8	Robotic cable 8 m*1
RA	Robotic cable 10 m*1
RB	Robotic cable 15 m*1
RC	Robotic cable 20 m*1

*1 Produced upon receipt of order (Robotic cable only)

*2 The standard cable should only be used on fixed parts.
For use on moving parts, select the robotic cable.

10 Controller

Nil	Without controller
C□1□□	With controller

C D 1 7 T

Communication protocol

E	EtherCAT®
9	EtherNet/IP™
P	PROFINET
D	DeviceNet™
L	IO-Link

For single axis

Mounting

7	Screw mounting
8*	DIN rail

* DIN rail is not included. It must be ordered separately. (Page 603-8)

Communication plug

connector for DeviceNet™

Nil	Without plug connector
S	Straight type
T	T-branch type

* Select "Nil" for anything other than DeviceNet™.

Compatible Controller

Type	EtherCAT® direct input type	EtherNet/IP™ direct input type	PROFINET direct input type	DeviceNet™ direct input type	IO-Link direct input type
Series	JXCE1	JXC91	JXCP1	JXCD1	JXCL1
Features	EtherCAT® direct input	EtherNet/IP™ direct input	PROFINET direct input	DeviceNet™ direct input	IO-Link direct input
Compatible motor	Step motor (Servo/24 VDC)				
Maximum number of step data	64 points				
Power supply voltage	24 VDC				
Reference page	Page 603-5				

LESH Series

Step Motor (Servo/24 VDC) Servo Motor (24 VDC)

Specifications

Step Motor (Servo/24 VDC)

Model		LESH8□		LESH16□		LESH25□		
Stroke [mm]		50, 75		50, 100		50, 100, 150		
Actuator specifications	Work load [kg] <small>Note 1) 3)</small>	Horizontal	2	1	8	5	12	8
		Vertical	0.5	0.25	2	1	4	2
	Pushing force [N] <small>30% to 70% Note 2) 3)</small>		6 to 15	4 to 10	23.5 to 55	15 to 35	77 to 180	43 to 100
	Speed [mm/s] <small>Note 1) 3)</small>		10 to 200	20 to 400	10 to 200	20 to 400	10 to 150	20 to 400
	Pushing speed [mm/s]		10 to 20	20	10 to 20	20	10 to 20	20
	Max. acceleration/deceleration [mm/s²]		5000					
	Positioning repeatability [mm]		±0.05					
	Lost motion [mm] <small>Note 4)</small>		0.15 or less					
	Screw lead [mm]		4	8	5	10	8	16
	Impact/Vibration resistance [m/s²] <small>Note 5)</small>		50/20					
Actuation type		Slide screw + Belt (R/L type), Slide screw (D type)						
Guide type		Linear guide (Circulating type)						
Operating temperature range [°C]		5 to 40						
Operating humidity range [%RH]		90 or less (No condensation)						
Electric specifications	Motor size	□20		□28		□42		
	Motor type	Step motor (Servo/24 VDC)						
	Encoder	Incremental A/B phase (800 pulse/rotation)						
	Rated voltage [V]	24 VDC ±10%						
	Power consumption [W] <small>Note 6)</small>	20		43		67		
	Standby power consumption when operating [W] <small>Note 7)</small>	7		15		13		
	Max. instantaneous power consumption [W] <small>Note 8)</small>	35		60		74		
	Type	Non-magnetizing lock						
Lock with specifications	Holding force [N]	24	2.5	300	48	500	77	
	Power consumption [W] <small>Note 10)</small>	3.5		2.9		5		
	Rated voltage [V]	24 VDC ±10%						

Note 1) Speed changes according to the work load. Check "Speed-Work Load Graph (Guide)" on page 341.

Note 2) Pushing force accuracy is ±20% (F.S.).

Note 3) The speed and force may change depending on the cable length, load and mounting conditions. Furthermore, if the cable length exceeds 5 m, then it will decrease by up to 10% for each 5 m. (At 15 m: Reduced by up to 20%)

Note 4) A reference value for correcting an error in reciprocal operation.

Note 5) Vibration resistance: No malfunction occurred in a test ranging between 45 to 2000 Hz. Test was performed in both an axial direction and a perpendicular direction to the lead screw. (Test was performed with the actuator in the initial state.)

Impact resistance: No malfunction occurred when the actuator was tested with a drop tester in both an axial direction and a perpendicular direction to the lead screw. (Test was performed with the actuator in the initial state.)

Note 6) The power consumption (including the controller) is for when the actuator is operating.

Note 7) The standby power consumption when operating (including the controller) is for when the actuator is stopped in the set position during the operation. Except during the pushing operation.

Note 8) The maximum instantaneous power consumption (including the controller) is for when the actuator is operating. This value can be used for the selection of the power supply.

Note 9) With lock only

Note 10) For an actuator with lock, add the power consumption for the lock.

Specifications

Servo Motor (24 VDC)

Model		LESH8□A			LESH16□A			LESH25 [□] A ^{Note 1)}		
Actuator specifications	Stroke [mm]	50, 75			50, 100			50, 100, 150		
	Work load [kg]	Horizontal		2	1	5	2.5	6	4	
		Vertical		0.5	0.25	2	1	2.5	1.5	
	Pushing force 50 to 100% [N] ^{Note 2)}	7.5 to 11	5 to 7.5	17.5 to 35	10 to 20	31 to 62	19 to 38			
	Speed [mm/s]	1 to 200	1 to 400	1 to 200	1 to 400	1 to 150	1 to 400			
	Pushing speed [mm/s] ^{Note 2)}	1 to 20								
	Max. acceleration/deceleration [mm/s ²]	5000								
	Positioning repeatability [mm]	±0.05								
	Lost motion [mm] ^{Note 3)}	0.15 or less								
	Screw lead [mm]	4	8	5	10	8	16			
Impact/Vibration resistance [m/s ²] ^{Note 4)}	50/20									
Actuation type	Slide screw + Belt (R/L type), Slide screw (D type)									
Guide type	Linear guide (Circulating type)									
Operating temperature range [°C]	5 to 40									
Operating humidity range [%RH]	90 or less (No condensation)									
Electric specifications	Motor size	□20			□28			□42		
	Motor output [W]	10			30			36		
	Motor type	Servo motor (24 VDC)								
	Encoder	Incremental A/B (800 pulse/rotation)/Z phase								
	Rated voltage [V]	24 VDC ±10%								
	Power consumption [W] ^{Note 5)}	58			84			144		
Lock unit specifications	Standby power consumption when operating [W] ^{Note 6)}	4 (Horizontal)/7 (Vertical)			2 (Horizontal)/15 (Vertical)			4 (Horizontal)/43 (Vertical)		
	Max. instantaneous power consumption [W] ^{Note 7)}	84			124			158		
	Type	Non-magnetizing lock								
Lock unit specifications	Holding force [N] ^{Note 8)}	24	2.5	300	48	500	77			
	Power consumption [W] ^{Note 9)}	3.5			2.9			5		
	Rated voltage [V]	24 VDC ±10%								

Note 1) LESH25DA is not available.

Note 2) The pushing force values for LESH8□A is 50% to 75%. Pushing force accuracy is ±20% (F.S.).

Note 3) A reference value for correcting an error in reciprocal operation.

Note 4) Vibration resistance: No malfunction occurred in a test ranging between 45 to 2000 Hz. Test was performed in both an axial direction and a perpendicular direction to the lead screw. (Test was performed with the actuator in the initial state.)

Impact resistance: No malfunction occurred when the actuator was tested with a drop tester in both an axial direction and a perpendicular direction to the lead screw. (Test was performed with the actuator in the initial state.)

Note 5) The power consumption (including the controller) is for when the actuator is operating.

Note 6) The standby power consumption when operating (including the controller) is for when the actuator is stopped in the set position during the operation. Except during the pushing operation.

Note 7) The maximum instantaneous power consumption (including the controller) is for when the actuator is operating. This value can be used for the selection of the power supply.

Note 8) With lock only

Note 9) For an actuator with lock, add the power consumption for the lock.

Weight

Step Motor (Servo/24 VDC), Servo Motor (24 VDC) Common

Model		Basic type/R type, Symmetrical type/L type						In-line motor type/D type							
		LESH8 [□] (A)		LESH16 [□] (A)		LESH25 [□] (A)		LESH8D(A)		LESH16D(A)		LESH25D			
Stroke [mm]		50	75	50	100	50	100	150	50	75	50	100	50	100	150
Product weight [kg]	Without lock	0.55	0.70	1.15	1.60	2.50	3.30	4.26	0.57	0.70	1.25	1.70	2.52	3.27	3.60
	With lock	—	0.76	—	1.71	2.84	3.64	4.60	0.63	0.76	1.36	1.81	2.86	3.61	3.94

LESH Series

Step Motor (Servo/24 VDC) Servo Motor (24 VDC)

Construction: Basic Type/R Type, Symmetrical Type/L Type

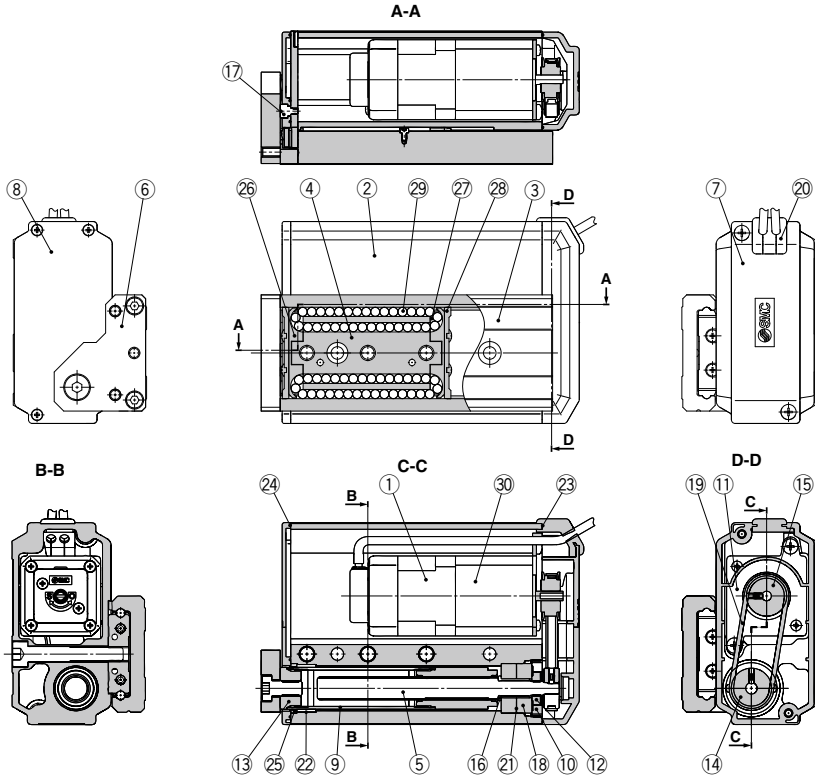

Component Parts

No.	Description	Material	Note
1	Motor	—	—
2	Body	Aluminum alloy	Anodized
3	Table	Stainless steel	Heat treatment + Electroless nickel plating
4	Guide block	Stainless steel	Heat treatment
5	Lead screw	Stainless steel	Heat treatment + Specially treated
6	End plate	Aluminum alloy	Anodized
7	Pulley cover	Synthetic resin	—
8	End cover	Synthetic resin	—
9	Rod	Stainless steel	—
10	Bearing stopper	Structural steel Brass	Electroless nickel plating Electroless nickel plating (LESH25R/L□ only)
11	Motor plate	Structural steel	—
12	Lock nut	Structural steel	Chromate treated
13	Socket	Structural steel	Electroless nickel plating
14	Lead screw pulley	Aluminum alloy	—
15	Motor pulley	Aluminum alloy	—
16	Spacer	Stainless steel	LESH25R/L□ only
17	Origin stopper	Structural steel	Electroless nickel plating
18	Bearing	—	—
19	Belt	—	—
20	Grommet	Synthetic resin	—
21	Sim ring	Structural steel	—

No.	Description	Material	Note
22	Bushing	—	Dust-protected option only
23	Pulley gasket	NBR	Dust-protected option only
24	End gasket	NBR	Dust-protected option only
25	Scraper	NBR	Dust-protected option only/Rod
26	Cover	Synthetic resin	—
27	Return guide	Synthetic resin	—
28	Scraper	Stainless steel + NBR	Linear guide
29	Steel ball	Special steel	—
30	Lock	—	With lock only

Replacement Parts/Belt

Model	Order no.
LESH8□	LE-D-1-1
LESH16□	LE-D-1-2
LESH25□	LE-D-1-3
LESH25□A	LE-D-1-4

Replacement Parts/Grease Pack

Applied portion	Order no.
Guide unit	GR-S-010 (10 g) GR-S-020 (20 g)

Construction: In-line Motor Type/D Type

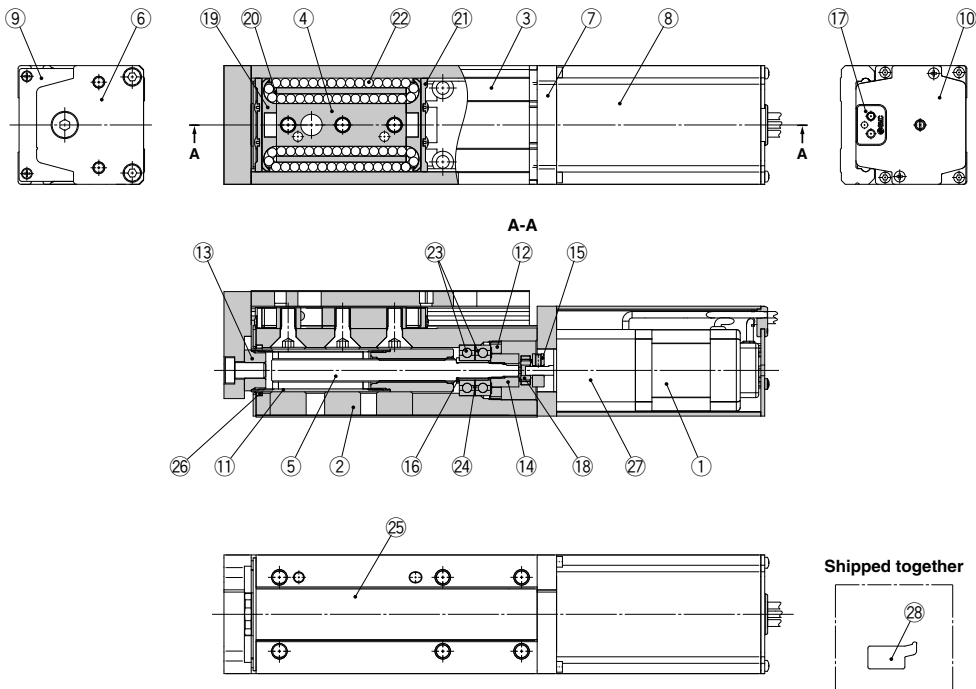

Component Parts

No.	Description	Material	Note
1	Motor	—	—
2	Body	Aluminum alloy	Anodized
3	Table	Stainless steel	Heat treatment + Electroless nickel plating
4	Guide block	Stainless steel	Heat treatment
5	Lead screw	Stainless steel	Heat treatment + Specially treated
6	End plate	Aluminum alloy	Anodized
7	Motor flange	Aluminum alloy	Anodized
8	Motor cover	Aluminum alloy	Anodized
9	End cover	Aluminum alloy	Anodized
10	Motor end cover	Aluminum alloy	Anodized
11	Rod	Stainless steel	—
12	Bearing stopper	Structural steel	Electroless nickel plating
		Brass	Electroless nickel plating (LESH25D□ only)
13	Socket	Structural steel	Electroless nickel plating
14	Hub (Lead screw side)	Aluminum alloy	—
15	Hub (Motor side)	Aluminum alloy	—
16	Spacer	Stainless steel	LESH25D□ only
17	Grommet	NBR	—
18	Spider	NBR	—
19	Cover	Synthetic resin	—
20	Return guide	Synthetic resin	—
21	Scraper	Stainless steel + NBR	Linear guide

No.	Description	Material	Note
22	Steel ball	Special steel	—
23	Bearing	—	—
24	Sim ring	Structural steel	—
25	Masking tape	—	—
26	Scraper	NBR	Dust-protected option only/ Rod
27	Lock	—	With lock only
28	Side holder	Aluminum alloy	Anodized

Optional Parts/Side Holder

Model	Order no.
LESH8D	LE-D-3-1
LESH16D	LE-D-3-2
LESH25D	LE-D-3-3

Replacement Parts/Grease Pack

Applied portion	Order no.
Guide unit	GR-S-010 (10 g) GR-S-020 (20 g)

LESH Series

Step Motor (Servo/24 VDC) Servo Motor (24 VDC)

Dimensions: Basic Type/R Type

LESH8R

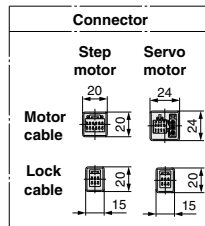
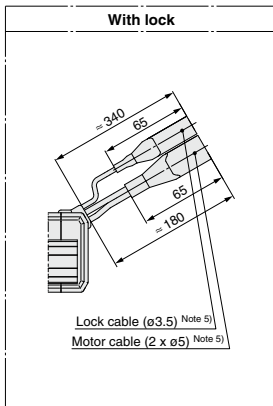
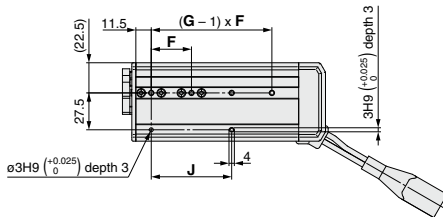
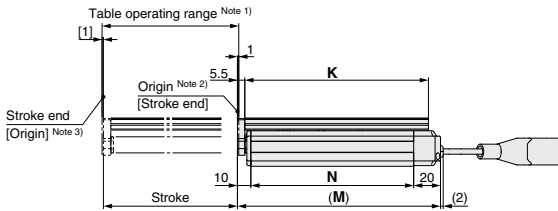
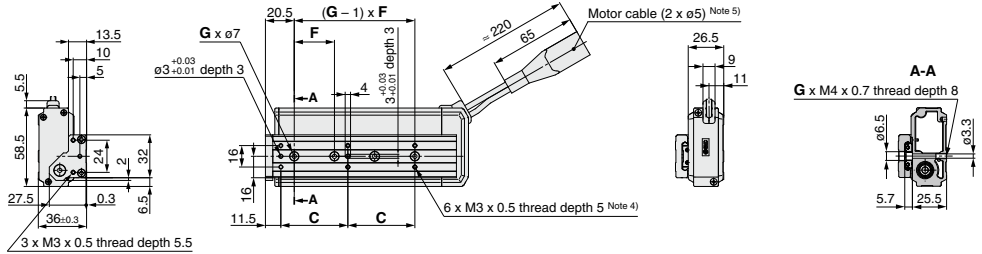

Model	C	F	G	J	K	M	N
LESH8R□□-50□□-□□□□	46	29	3	58	111	125.5	95.5
LESH8R□□-75□□-□□□□	50	30	4	60	137	151.5	121.5

Note 1) Range within which the table can move when it returns to origin. Make sure a workpiece mounted on the table does not interfere with the workpieces and facilities around the table.

Note 2) Position after return to origin.

Note 3) [] for when the direction of return to origin has changed.

Note 4) If workpiece retaining screws are too long, they can touch the guide block and cause a malfunction.

Use screws that are between the maximum and minimum screw-in depths in length.

Note 5) Secure the motor cable and lock cable so that the cables are not repeatedly bent.

Dimensions: Basic Type/R Type

LESH16R

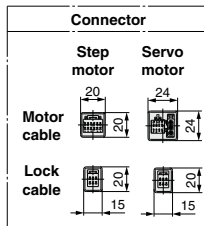
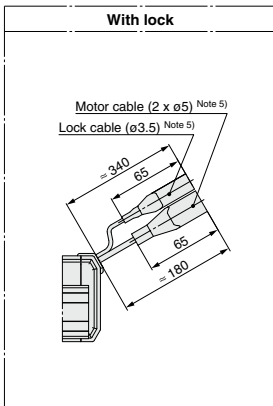
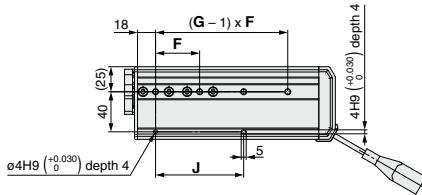
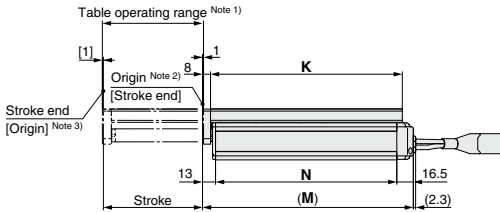
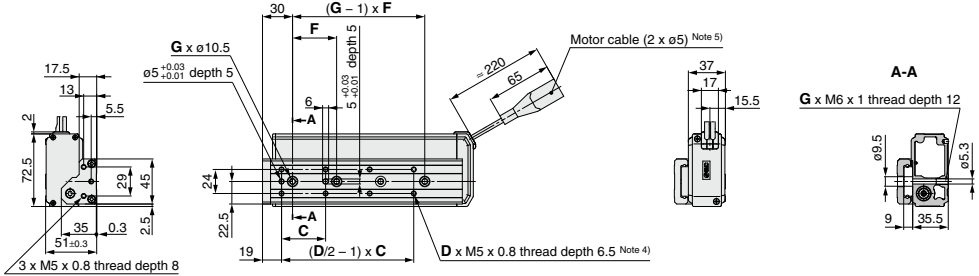

Model	C	D	F	G	J	K	M	N
LESH16R□□-50□□-□□□□	40	6	45	2	45	116.5	135.5	106
LESH16R□□-100□□-□□□□	44	8	44	4	88	191.5	210.5	181

Note 1) Range within which the table can move when it returns to origin. Make sure a workpiece mounted on the table does not interfere with the workpieces and facilities around the table.

Note 2) Position after return to origin.

Note 3) [] for when the direction of return to origin has changed.

Note 4) If workpiece retaining screws are too long, they can touch the guide block and cause a malfunction.

Use screws that are between the maximum and minimum screw-in depths in length.

Note 5) Secure the motor cable and lock cable so that the cables are not repeatedly bent.

LESH Series

Step Motor (Servo/24 VDC) Servo Motor (24 VDC)

Dimensions: Basic Type/R Type

LESH25R

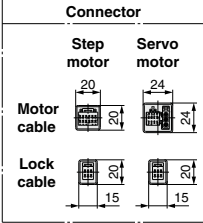
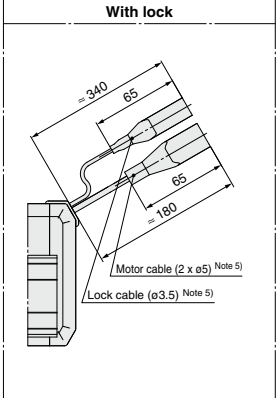
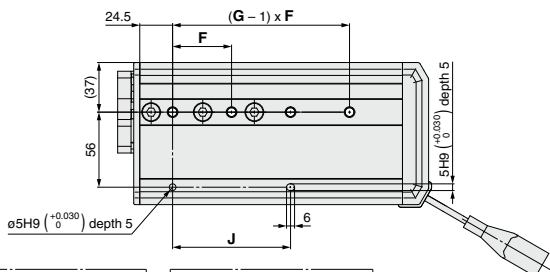
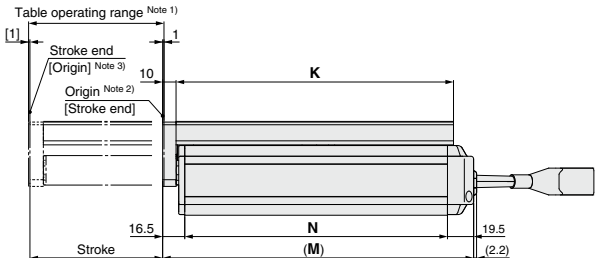
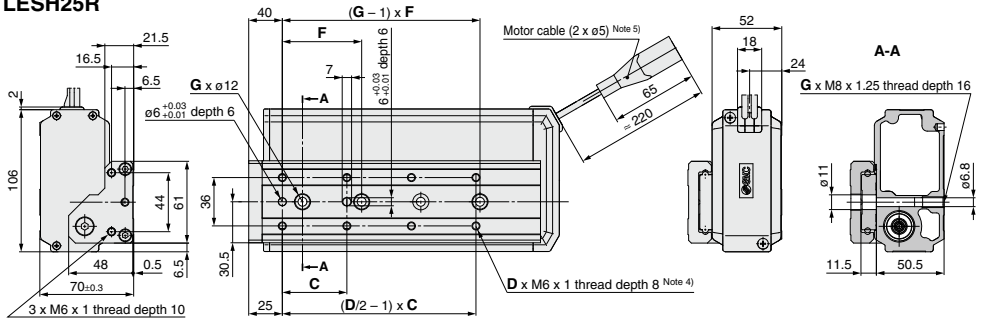

Model	C	D	F	G	J	K	M	N
LESH25R□□-50□□-□□□□□□	75	4	80	2	80	143	168	132
LESH25R□□-100□□-□□□□□□	48	8	44	4	88	207	232	196
LESH25R□□-150□□-□□□□□□	65	8	66	4	132	285	310	274

Note 1) Range within which the table can move when it returns to origin. Make sure a workpiece mounted on the table does not interfere with the workpieces and facilities around the table.
 Note 2) Position after return to origin.
 Note 3) [] for when the direction of return to origin has changed.
 Note 4) If workpiece retaining screws are too long, they can touch the guide block and cause a malfunction. Use screws that are between the maximum and minimum screw-in depths in length.
 Note 5) Secure the motor cable and lock cable so that the cables are not repeatedly bent.

Dimensions: Symmetrical Type/L Type

LESH8L

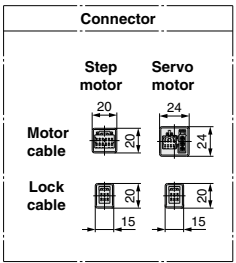
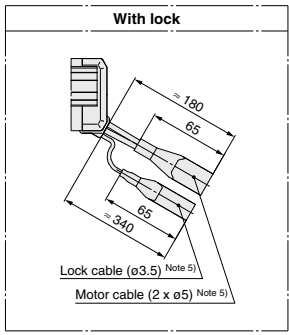
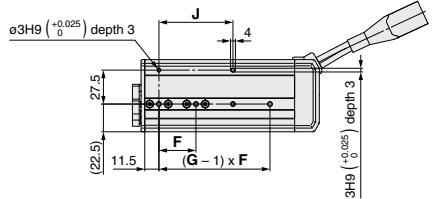
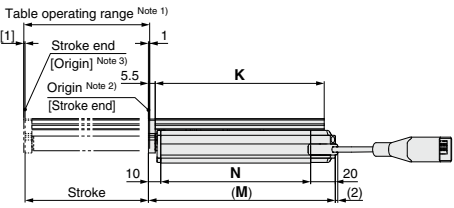
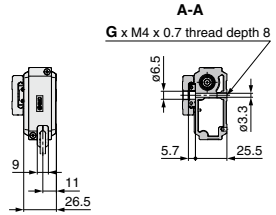
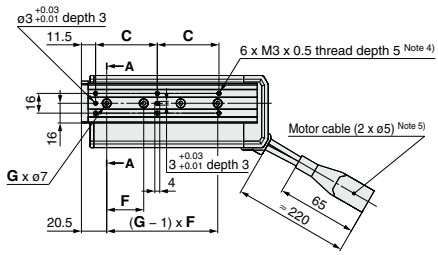
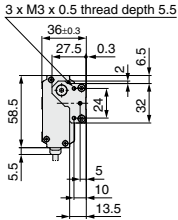

Model	C	F	G	J	K	M	N
LESH8L□□-50□□-□□□□	46	29	3	58	111	125.5	95.5
LESH8L□□-75□□-□□□□	50	30	4	60	137	151.5	121.5

Note 1) Range within which the table can move when it returns to origin. Make sure a workpiece mounted on the table does not interfere with the workpieces and facilities around the table.
 Note 2) Position after return to origin.
 Note 3) [] for when the direction of return to origin has changed.
 Note 4) If workpiece retaining screws are too long, they can touch the guide block and cause a malfunction. Use screws that are between the maximum and minimum screw-in depths in length.
 Note 5) Secure the motor cable and lock cable so that the cables are not repeatedly bent.

LESH Series

Step Motor (Servo/24 VDC) Servo Motor (24 VDC)

Dimensions: Symmetrical Type/L Type

LESH16L

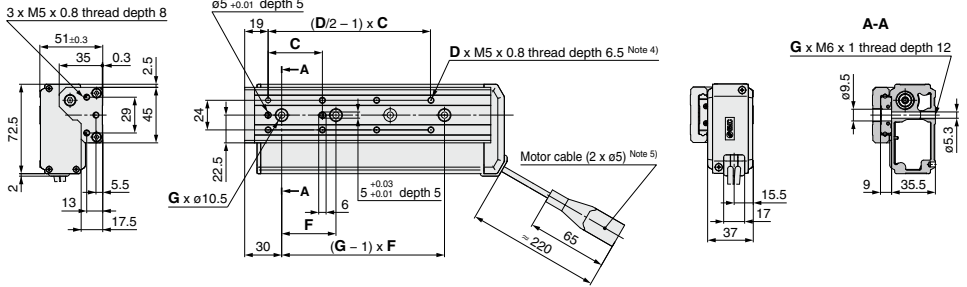
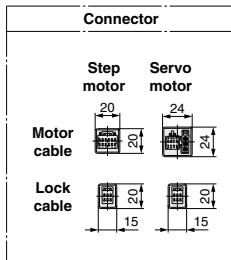
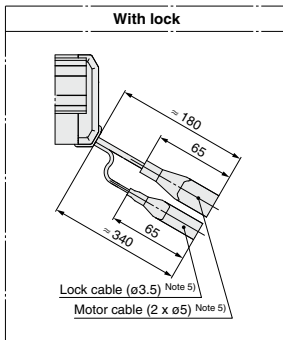
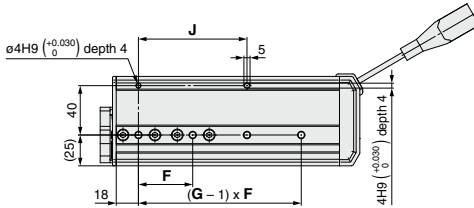
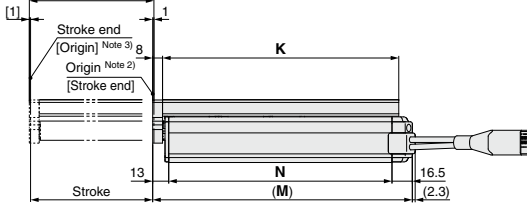

Table operating range (Note 1)



Model	C	D	F	G	J	K	M	N
LESH16L□□-50□□-□□□□□□	40	6	45	2	45	116.5	135.5	106
LESH16L□□-100□□-□□□□□□	44	8	44	4	88	191.5	210.5	181

[mm]

Note 1) Range within which the table can move when it returns to origin. Make sure a workpiece mounted on the table does not interfere with the workpieces and facilities around the table.

Note 2) Position after return to origin.

Note 3) [] for when the direction of return to origin has changed.

Note 4) If workpiece retaining screws are too long, they can touch the guide block and cause a malfunction. Use screws that are between the maximum and minimum screw-in depths in length.

Note 5) Secure the motor cable and lock cable so that the cables are not repeatedly bent.

Dimensions: Symmetrical Type/L Type

LESH25L

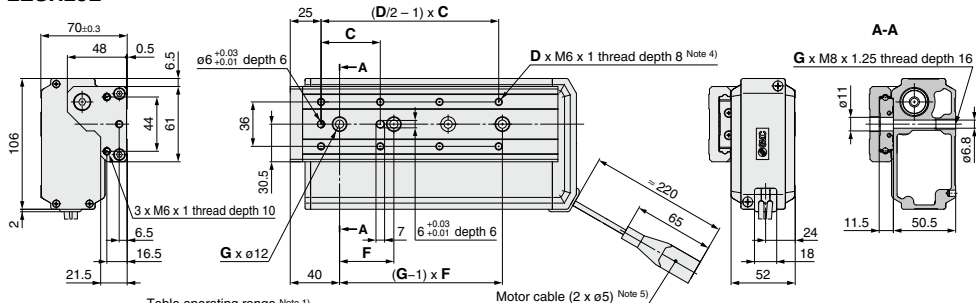
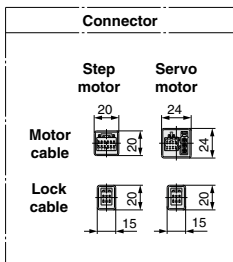
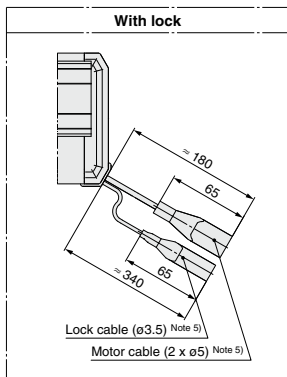
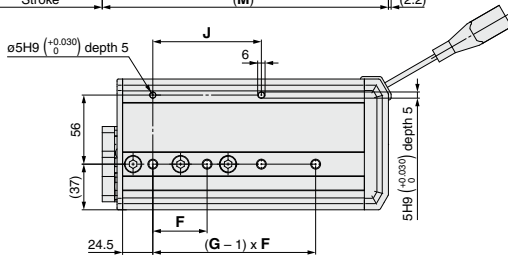
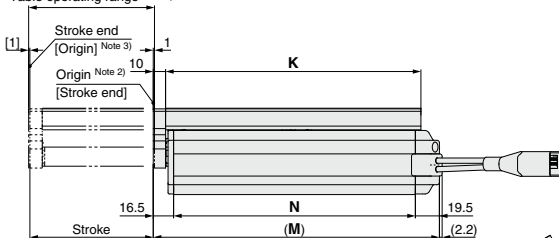

Table operating range (Note 1)



Model	C	D	F	G	J	K	M	N
LESH25L□□-50□□□□□□□□	75	4	80	2	80	143	168	132
LESH25L□□-100□□□□□□□□	48	8	44	4	88	207	232	196
LESH25L□□-150□□□□□□□□	65	8	66	4	132	285	310	274

Note 1) Range within which the table can move when it returns to origin. Make sure a workpiece mounted on the table does not interfere with the workpieces and facilities around the table.

Note 2) Position after return to origin.

Note 3) [] for when the direction of return to origin has changed.

Note 4) If workpiece retaining screws are too long, they can touch the guide block and cause a malfunction.

Note 5) Use screws that are between the maximum and minimum screw-in depths in length.

Note 6) Secure the motor cable and lock cable so that the cables are not repeatedly bent.

LESH Series

Step Motor (Servo/24 VDC) Servo Motor (24 VDC)

Dimensions: In-line Motor Type/D Type

LESH8D

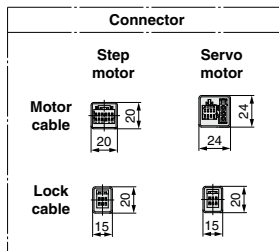
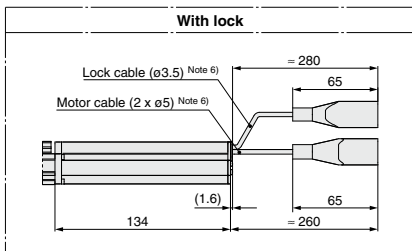
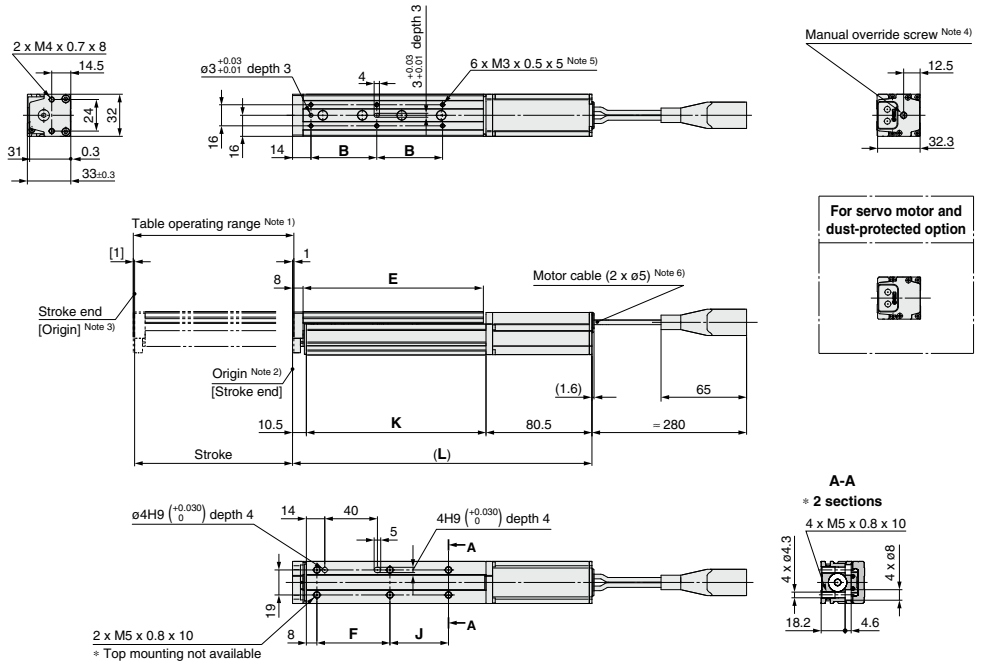

Model	L	B	E	F	J	K
LESH8D□□-50□□-□□□□□□	201.5	46	111	54.5	19.5	110.5
LESH8D□□-50B□□-□□□□□□	255					
LESH8D□□-75□□-□□□□□□	227.5	50	137	55.5	44.5	136.5
LESH8D□□-75B□□-□□□□□□	281					

[mm]

Note 1) Range within which the table can move when it returns to origin. Make sure a workpiece mounted on the table does not interfere with the workpieces and facilities around the table.

Note 2) Position after return to origin.

Note 3) [] for when the direction of return to origin has changed.

Note 4) The distance between the motor end cover and the manual override screw is up to 16 mm.

The motor end cover hole size is ø5.5.

Note 5) If workpiece retaining screws are too long, they can touch the guide block and cause a malfunction.

Use screws that are between the maximum and minimum screw-in depths in length.

Note 6) Secure the motor cable and lock cable so that the cables are not repeatedly bent.

Dimensions: In-line Motor Type/D Type

LESH16D

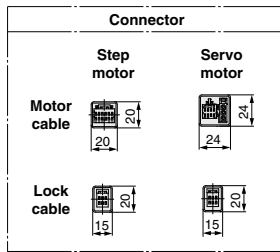
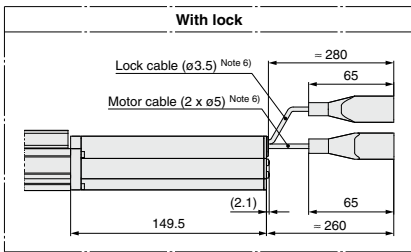
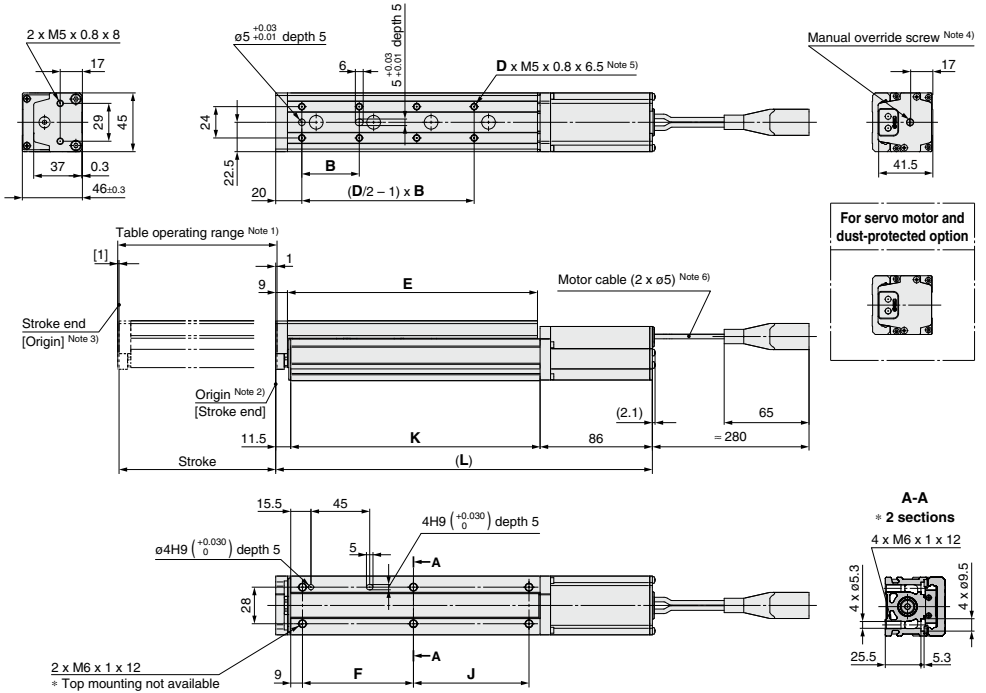

Model	L	B	D	E	F	J	K
LESH16D□□-50□□-□□□□□□	219.5	40	6	116.5	65	39.5	122
LESH16D□□-50B□□-□□□□□□	283						
LESH16D□□-100□□-□□□□□□	288.5	44	8	191.5	85	88.5	191
LESH16D□□-100B□□-□□□□□□	352						

- Note 1) Range within which the table can move when it returns to origin. Make sure a workpiece mounted on the table does not interfere with the workpieces and facilities around the table.
- Note 2) Position after return to origin.
- Note 3) [] for when the direction of return to origin has changed.
- Note 4) The distance between the motor end cover and the manual override screw is up to 17 mm.
The motor end cover hole size is ø5.5.
- Note 5) If workpiece retaining screws are too long, they can touch the guide block and cause a malfunction. Use screws that are between the maximum and minimum screw-in depths in length.
- Note 6) Secure the motor cable and lock cable so that the cables are not repeatedly bent.

LESH Series

Step Motor (Servo/24 VDC) Servo Motor (24 VDC)

Dimensions: In-line Motor Type/D Type

LESH25D

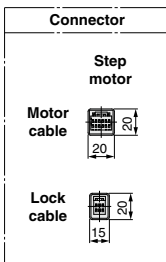
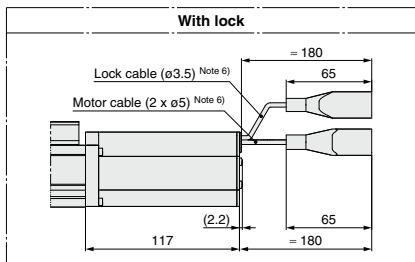
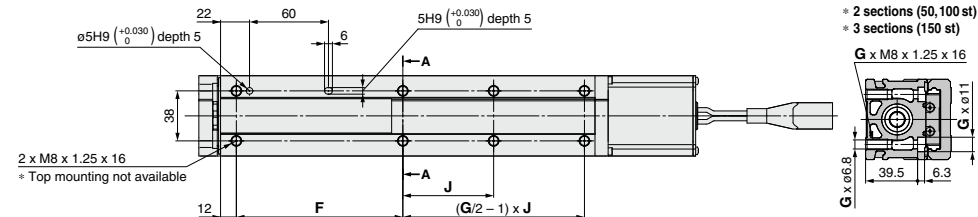
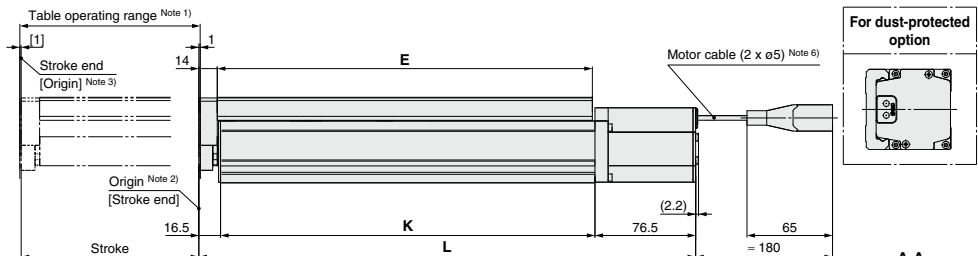
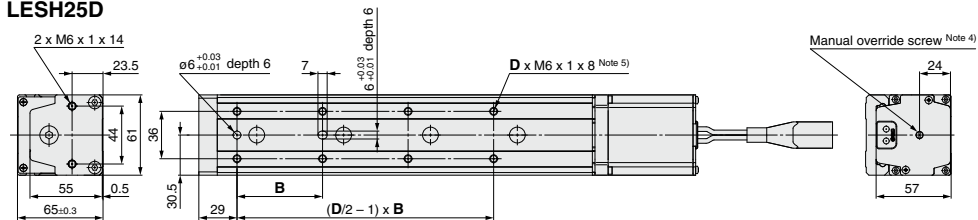

[mm]

Model	L	B	D	E	F	G	J	K
LESH25D□-50□□□□□□□□	237.5	75	4	143	84	4	40.5	144.5
LESH25D□-50B□□□□□□□□	278							
LESH25D□-100□□□□□□□□	299.5	48	8	207	98.5	6	88	206.5
LESH25D□-100B□□□□□□□□	340							
LESH25D□-150□□□□□□□□	377.5	65		285	126.5	6	69	284.5
LESH25D□-150B□□□□□□□□	418							

Note 1) Range within which the table can move when it returns to origin. Make sure a workpiece mounted on the table does not interfere with the workpieces and facilities around the table.

Note 2) Position after return to origin.

Note 3) [] for when the direction of return to origin has changed.

Note 4) The distance between the motor end cover and the manual override screw is up to 4 mm.

The motor end cover hole size is $\phi 5.5$.

Note 5) If workpiece retaining screws are too long, they can touch the guide block and cause a malfunction.

Use screws that are between the maximum and minimum screw-in depths in length.

Note 6) Secure the motor cable and lock cable so that the cables are not repeatedly bent.

Side Holder (In-line Motor Type/D Type)

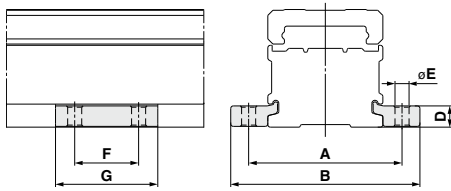

[mm]

Part no. <small>Note)</small>	A	B	D	E	F	G	Applicable model
LE-D-3-1	45	57.6	6.7	4.5	20	33	LESH8D
LE-D-3-2	60	74	8.3	5.5	25	40	LESH16D
LE-D-3-3	81	99	12	6.6	30	49	LESH25D

Note) Model numbers for 1 side holder.

LES/LESH Series Electric Slide Tables/ Specific Product Precautions 1



Be sure to read this before handling the products. Refer to back page 50 for Safety Instructions and pages 3 to 8 for Electric Actuator Precautions.

Design

⚠ Caution

1. Do not apply a load in excess of the specification limits.

Select a suitable actuator by work load and allowable moment. If the product is used outside of the specification limits, the eccentric load applied to the guide will be excessive and have adverse effects such as creating play on the guide, degrading accuracy and shortening the life of the product.

2. Do not use the product in applications where excessive external force or impact force is applied to it.

This can cause failure.

Handling

⚠ Caution

1. INP output signal

1) Positioning operation

When the product comes within the set range by step data [In position], the INP output signal will turn on.

Initial value: Set to [0.50] or higher.

2) Pushing operation

When the effective force exceeds step data [Trigger LV], the INP output signal will turn on. Use the product within the specified range of [Pushing force] and [Trigger LV].

To ensure that the actuator pushes the workpiece with the set [Pushing force], it is recommended that the [Trigger LV] be set to the same value as the [Pushing force].

2. When the pushing operation is used, be sure to set to [Pushing operation]. Never hit at the stroke end except during return to origin.

When incorrect instructions are inputted, such as using the product outside of the specification limits or operation outside of actual stroke through changes in the controller/driver setting and/or origin position, the table may collide against the stroke end of the actuator. Check these points before use.

If the table collides against the stroke end of the actuator, the guide, belt or internal stopper can be broken. This may lead to abnormal operation.



Handle the actuator with care when it is used in the vertical direction as the workpiece will fall freely from its own weight.

3. Use the product with the following moving force.

- Step motor (Servo/24 VDC): 100%
- Servo motor (24 VDC) : 250%

If the moving force is set below the above values, it may cause an alarm.

Handling

⚠ Caution

4. The actual speed of this actuator is affected by the load.

Check the model selection section of the catalog.

5. Do not apply a load, impact or resistance in addition to the transferred load during return to origin.

Additional force will cause the displacement of the origin position since it is based on detected motor torque.

6. The table and guide block are made of special stainless steel, but can rust in an environment where droplets of water adhere to it.

7. Do not dent, scratch or cause other damage to the body, table and end plate mounting surfaces.

This may cause unevenness in the mounting surface, play in the guide or an increase in the sliding resistance.

8. Do not dent, scratch or cause other damage to the surface over which the rail and guide will move.

This may cause play or an increase in the sliding resistance.

9. Do not apply strong impact or an excessive moment while mounting a workpiece.

If an external force over the allowable moment is applied, it may cause play in the guide or an increase in the sliding resistance.

10. Keep the flatness of mounting surface 0.02 mm or less.

Unevenness of a workpiece or base mounted on the body of the product may cause play on the guide and increased sliding resistance. Do not deform the mounting surface by mounting with workpieces tucked in.

11. Do not drive the main body with the table fixed.

12. When mounting the product, for R/L type fixed cable, keep the following dimension or more for bends in the cable. For D type, keep a 40 mm or longer diameter for bends in the cable.

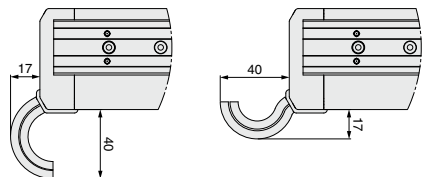

LES/LESH Series Electric Slide Tables/ Specific Product Precautions 2

Be sure to read this before handling the products. Refer to back page 50 for Safety Instructions and pages 3 to 8 for Electric Actuator Precautions.



Handling

⚠ Caution

13. When mounting the product, use screws with adequate length and tighten them to the maximum torque or less.

Tightening the screws with a higher torque than recommended may cause a malfunction, whilst the tightening with a lower torque can cause the displacement of the mounting position or in extreme conditions the actuator could become detached from its mounting position.

Body fixed/ Side mounting (Body tapped)	Model	Screw size	Max. tightening torque [N·m]	L [mm] (Max. screw-in depth)
	LES18R/L	M4 x 0.7	1.5	8
	LES18D	M5 x 0.8	3	10
	LES16R/L			
	LES16D	M6 x 1	5.2	12
	LESH16□			
	LES25R/L			
	LES25D			
	LESH25□			
	LES25D			

Body fixed/ Side mounting (Through-hole)	Model	Screw size	Max. tightening torque [N·m]	L [mm]
	LES8R/L	M3 x 0.5	0.63	23.5
	LESH8R/L			25.5
	LES16R/L			18.2
	LES16D	M4 x 0.7	1.5	33.5
	LESH16R/L			25.2
	LESH16D			35.5
	LES25R/L			25.5
	LES25D			49
	LESH25R/L			39.8
	LES25D	M6 x 1	5.2	50.5
LESH25D	39.5			

Workpiece fixed/ Front mounting	Model	Screw size	Max. tightening torque [N·m]	L [mm]		
	LES8R/L	M3 x 0.5	0.63	6		
	LESH8R/L			5.5		
	LES16R/L	M4 x 0.7	1.5	8		
	LES16D			M5 x 0.8	3	12
	LESH16□					10
	LES25R/L	14				
	LES25D	M6 x 1	5.2			10
	LESH25R/L					14

To prevent the workpiece retaining screws from penetrating the end plate, use screws that are 0.5 mm or shorter than the maximum screw-in depth. If long screws are used, they can touch the end plate and cause a malfunction.

Workpiece fixed/ Top mounting	Model	Screw size	Max. tightening torque [N·m]	L (Min. to Max. screw-in depth) [mm]
	LES8□	M3 x 0.5	0.63	2.1 to 4.1
	LESH8□			5 (Max.)
	LES16□	M4 x 0.7	1.5	2.7 to 5.7
	LESH16□			6.5 (Max.)
	LES25□	M5 x 0.8	3	3.3 to 7.3
	LESH25□			8 (Max.)

To prevent the workpiece retaining screws from touching the guide block, use screws that are the maximum screw-in depth or less. If long screws are used, they can touch the guide block and cause a malfunction.

Body fixed/Side mounting (Side holder)

Model	Screw size	Max. tightening torque [N·m]	L [mm]
LES18D	M4 x 0.7	1.5	6.7
LES16D	M5 x 0.8	3	8.3
LES125D	M6 x 1	5.2	12

When using the side holders to install the actuator, be sure to use the positioning pin. It can be displaced when vibration or excessive external force is applied.

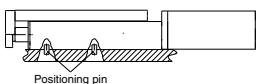

Positioning pin

14. In pushing operation, set the product to a position of at least 0.5 mm away from a workpiece. (This position is referred to as a pushing start position.)

If the product is set to the same position as a workpiece, the following alarms may be generated and operation may become unstable.

a. "Posn failed" alarm is generated.

The product cannot reach a pushing start position due to variation in the width of workpieces.

b. "Pushing ALM" alarm is generated.

The product is pushed back from a pushing start position after starting to push.

15. When external force is applied to the table, it is necessary to reduce the work load for the sizing.

When a cable duct or flexible moving tube is attached to the actuator, the sliding resistance of the table increases and may lead to operational failure of the product.

16. When using the side holders to install the actuator, use within the following dimension range.

Otherwise, installation balance will deteriorate and cause loosening.

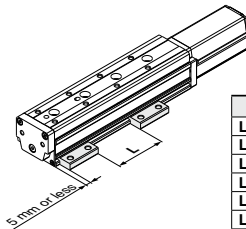

Model	L [mm]
LES18D□-30	5 to 10
LES18D□-50	20 to 30
LES18D□-75	50 to 60
LES16D□-30	5 to 10
LES16D□-50	20 to 30
LES16D□-75	60 to 75
LES16D□-100	85 to 100
LES125D□-30	5 to 15
LES125D□-50	25 to 35
LES125D□-75	60 to 75
LES125D□-100	70 to 100
LES125D□-125	155 to 170
LES125D□-150	160 to 180

17. For the LES□□D, do not grasp or peel off a masking tape on the bottom of the body.

The masking tape may peel off and foreign matter may get inside the actuator.

18. For the LES□□D, a gap will form between the motor flange and table when the table moves (marked with the arrow below). Be careful not to put hands or fingers in a gap.

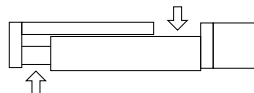

LES/LESH Series Electric Slide Tables/ Specific Product Precautions 3



Be sure to read this before handling the products. Refer to back page 50 for Safety Instructions and pages 3 to 8 for Electric Actuator Precautions.

Handling

⚠ Caution

19. When mounting the body with through-holes in the following mounting orientations, make sure to use two side holders as shown in the figures.

Otherwise, installation balance will deteriorate and cause loosening.

Bottom mounting

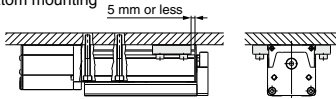

Wall mounting

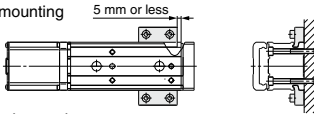

Vertical mounting

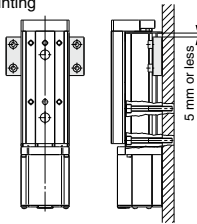

20. Install the body as shown below with the ○.

Since the product support becomes unstable, it may cause a malfunction, noise or an increase in the deflection.

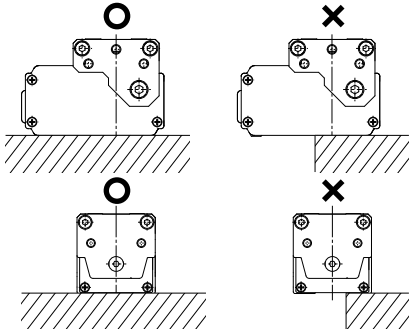

21. Even with the same product number, the table of some products can be moved by hand and the table of some products cannot be moved by hand. However, there is no abnormality with these products. (Without lock)

This difference is caused because there is a little variation with the positive efficiency (when the table is moved by the motor) and there is a large variation with the reverse-efficiency (when the table is moved manually) due to the product characteristics. There is hardly any difference among products when they are operated by the motor.

Handling

⚠ Caution

22. For LES□□^R, remove the cap and operate the manual override screw with a hexagon wrench.

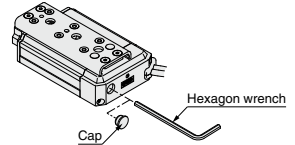

Maintenance

⚠ Warning

1. Ensure that the power supply is stopped before starting maintenance work or replacement of the product.
2. For lubrication, wear protective glasses.
3. Perform maintenance according to the following requirements.

• Maintenance frequency

Perform maintenance according to the table below.

Frequency	Appearance check	Belt check
Inspection before daily operation	○	—
Inspection every 6 months*	—	○
Inspection every 250 km*	—	○
Inspection every 5 million cycles*	—	○

* Select whichever comes first.

• Items for visual appearance check

1. Loose set screws, Abnormal dirt
2. Check of flaw and cable joint
3. Vibration, Noise

• Items for belt check (R/L type only)

Stop operation immediately and replace the belt when belt appear to be below.

- a. **Tooth shape canvas is worn out.**
Canvas fiber becomes fuzzy. Rubber is removed and the fiber becomes whitish. Lines of fibers become unclear.
- b. **Peeling off or wearing of the side of the belt**
Belt corner becomes round and frayed thread sticks out.
- c. **Belt partially cut**
Belt is partially cut. Foreign matter caught in teeth other than cut part causes flaw.
- d. **Vertical line of belt teeth**
Flaw which is made when the belt runs on the flange.
- e. **Rubber back of the belt is softened and sticky.**
- f. **Crack on the back of the belt**