



Linear Motors and Stages



Linear Motor Solutions

Baldor provides industry with the widest range of linear motors, linear stages and controls. Being a leader in linear motor design and manufacturing, Baldor continually develops advanced products and innovations to meet a variety of linear motion applications.

Linear motors provide unique speed and positioning performance advantages. Linear motors provide direct-coupled motion and eliminate mechanical transmission devices. The rugged mechanical design provides accurate motion and precision positioning for hundreds of millions of cycles. Baldor linear motors and stages are used in thousands of successful applications worldwide.

Some advantages of linear products include, higher linear velocities, non-wearing moving part, and direct linear motion without mechanical linkages, therefore no backlash. Other advantages are:

- › High repeatability – resolution to 0.1 microns [0.000004 inch] – all parts produced are identical
- › Highly accurate – to 2.5 micron/300 mm [0.0001 inch/ft] – provides precision in the operation
- › No backlash – direct drive has no backlash - this improves accuracy of the part or operation
- › Faster acceleration – from 1 to over 10 g's – this leads to shortened cycle times and improved productivity.
- › Higher velocities – speeds to over 8 meters/sec [300 inches/sec] – to position the payload faster
- › Long term reliability – only two parts with only one moving part – this leads to simplicity and improves the applications reliability
- › No wear or maintenance – no contacting parts, thus reducing component friction and wear
- › Ease of Installation – linear motors are designed to allow for alignment tolerances. Misalignment produces no degradation of performance.
- › Clean Room compatibility – can be customized to meet most clean rooms



Page 8
Cog-free Brushless
High performance linear motor



Page 11
Iron-Core Brushless
High performance linear motor



Page 15 & 19
Single & Dual-Axis Steppers
Open loop stepper motor



Page 22
AC Induction Motor
High performance linear induction motor

Typical Applications:

- › Baggage Handling
- › Bottle Labeling
- › Coordinate Measurement
- › Diagnostic Probe
- › Disk Certifier
- › Electronic Assembly
- › Food Processing
- › Inspection Equipment
- › Laser Cutting Machines
- › Laser Surgery Machine
- › Machine Tool
- › Mail Sorting
- › Material Handling
- › Medical
- › MRI & X Ray Equip
- › Packaging Machinery
- › Part Transfer Systems
- › PCB Assembly/Inspection
- › PCB Drilling
- › Pick & Place Systems
- › Precision Grinding
- › Printing Application
- › Robotic Applications
- › Semiconductor
- › Sorting Machines
- › Surface Mount Assembly
- › Wafer Etch Machines
- › Vision Inspection



Page 27
Linear Motors
 Other linear motor technology



Page 29
Linear Stages
 High performance linear stages



Page 33
Engineering Information

What is a Linear Motor

The same electromagnetic force that produces torque in a rotary motor also produces direct force in a linear motor. For example, a permanent magnet DC linear motor is similar to a permanent magnet DC rotary motor and an AC induction linear motor is similar to a squirrel cage induction motor.

Take a rotary motor, split it radially along its axis of rotation and flatten it out. The result is a flat linear motor that produces direct linear force instead of torque. It follows that linear motors utilize the same controls as rotary motors. And similar to a rotary motor with rotary encoders, linear motor positioning is provided by a linear encoder.

Variety of Linear Motor Technologies

As there are a variety of motor technologies available in the rotary world, there are a variety of technologies in the linear world. These include brushless, cog-free, permanent magnet, brush-type, induction and steppers. There are also custom linear products such as polynoids, moving magnets and moving coils. Each technology brings advantages to the application.

Linear Motors and Stages

Linear motors consist of two parts – a stationary track or “platen” and a moving “forcer”. They can be provided as a stand-alone linear motor assembly or as a complete stage – built with a housing or enclosure with linear bearings, limit switches, cable track/carrier, protective bellows and linear encoder in a wide variety of lengths.

Selecting the Correct Drive

Linear motors typically produce a peak force three times continuous force. Some drives are rated at only two times so this must be taken into consideration when sizing the drive for the motor.

Baldor produces the widest range of linear motors and stages. Contact us and let Baldor assist you in selecting the linear motor technology best suited for your application, to deliver optimum machine performance in your application. Baldor also has drives and motion controllers for powering and positioning of linear motors.

Imaginary process of unrolling a rotary motor

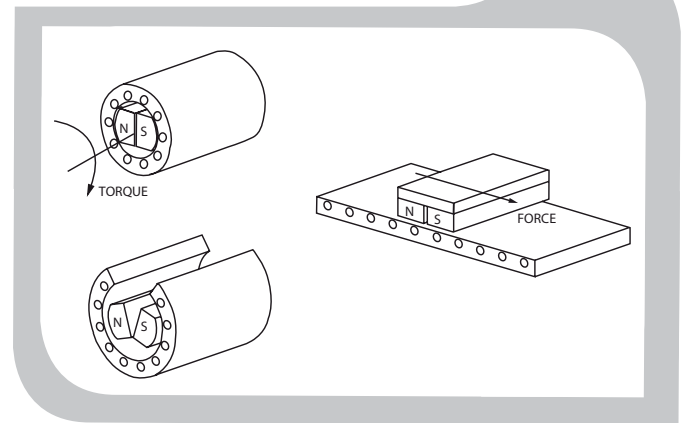

Tubular non-commutated DC Linear Motor

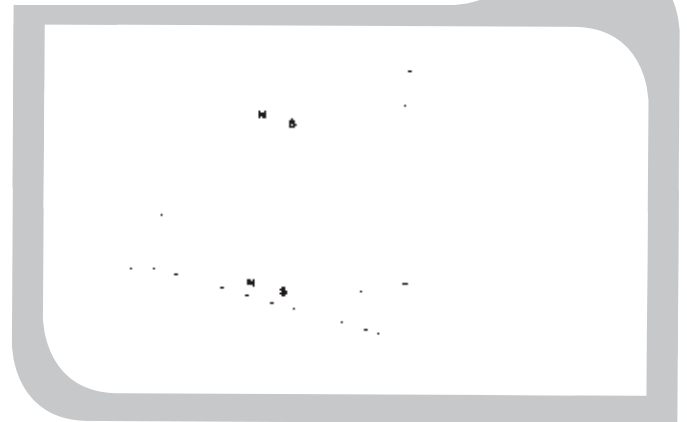

The Benefits of Linear Motors Over Traditional Technologies

- › Direct drive, zero backlash for higher accuracy
- › Non-contact, non-wearing for enhanced reliability
- › Simplicity, no mechanical linkages provides faster installation
- › High acceleration and velocity reduces cycle times
- › High accuracy and repeatability provides better quality control
- › Low maintenance and long life lowers cost of ownership
- › Longer lengths with no performance degradation

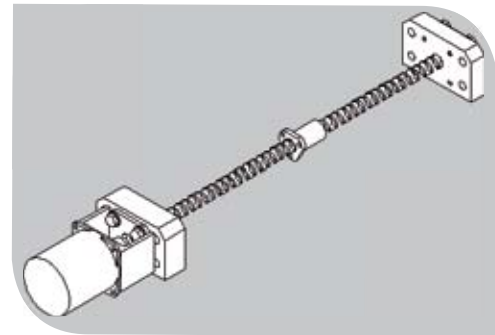
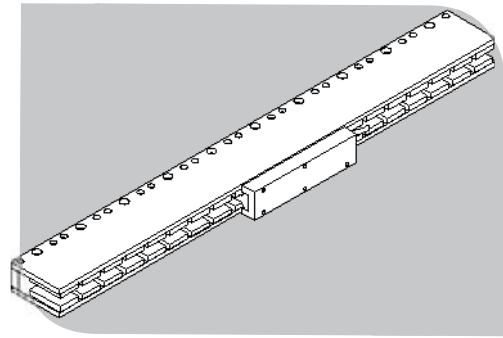

Linear Motor › Higher Through Put › Higher Productivity

Material Comparison Between Linear Motors and Ballscrews/Timing Belts

	Closed loop		Open loop	
	Ball screw with Rotary Motor	Linear Motor	Timing Belt with Rotary Stepper	Linear Motor
Rotary to Linear Mechanism	■	⊕	⊕	⊕
Motor Mount	■	⊕	■	⊕
Nut Mount	■	⊕	⊕	⊕
Coupling	■	⊕	■	⊕
End Bearing	■	⊕	■	⊕
Motor	■	■	■	■
Encoder (linear)	■	■	⊕	⊕
Rails (+ Bearings)	⊕	■	⊕	■

■ Required ⊕ Not Required

› Performance comparison

Max. Speed m/s [ips]	1 [38]	10+ [400+]	2.5 [100]	10+ [400+]
Max. Accel.	20 m/s ² (2g)	98+ m/s ² (10+g)	20 m/s ² (2g)	98+ m/s ² (10+g)
Repeatability μm (inch)	50(0.002)*	1(0.00004)**	250 [0.001]	10 [0.0004]

* Dependent on ball screw pitch, resolution and feedback

** Dependent on encoder specification

› Linear Motor Characteristics Overview

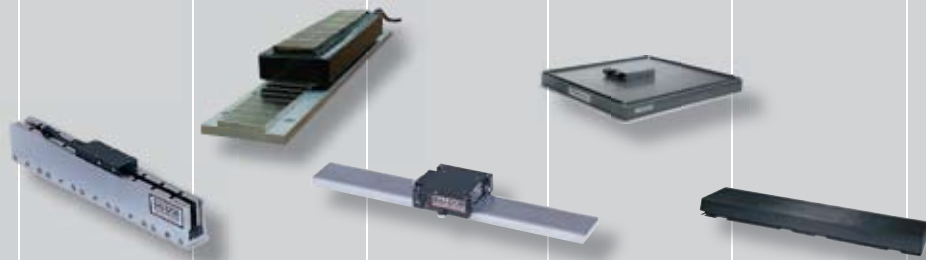

Page 8

Page 11

Page 15

Page 19

Page 22

Motor Series		Cog-free Brushless LMC ^F	Iron Core Brushless LMIC	Single Axis Stepper LMSS (7)	Dual Axis Stepper LMDS (7)	AC Induction LMAC
Continuous Force	N Lbs	5.3 - 771 1.2 - 173	80 - 5179 18 - 1164	10 - 240 2.2 - 65 (5)	15 - 134 3.3 - 30 (5)	62 - 445 14 - 100
Peak Force @ 10% Duty	N Lbs	16 - 2300 3.6 - 517	213 - 13813 48 - 3105	10 - 240 2.2 - 65 (6)	15 - 134 3.3 - 30 (6)	311 - 2224 (15% Duty) 70 - 500
Acceleration	(3) m/s ² g's	98 10	98 10	9.8 1	9.8 1	9.8 1
Maximum Speed	m/s in/sec	10 400	8 328	2 80	1.5 60	6.8 [270] @ 60 Hz 50.8 [2000] @ 40 Hz
Maximum Stroke	m in	Unlimited	Unlimited	Unlimited	1.0 x 2.7 42 x 106	Unlimited
Accuracy	(1) μm/ 300mm (4) in/ft	5 0.0002	5 0.0002	25 0.001	25 0.001	2.5 0.0001
Repeatability	(1) μm (4) in	1 0.00004	1 0.00004	10 0.0004	5.08 0.0002	1 0.00004 (2)
Positioning Type		Closed Loop	Closed Loop	Open or Closed Loop	Open Loop	Open or Closed Loop
Drive/Control		3-Phase Brushless Control	3-Phase Brushless Control	Stepper Motor Drive	Stepper Motor Drive	Single or 3 Phase AC Line or Adjustable Speed
Load Support		Customer Supplied Bearing	Customer Supplied Bearing	Roller or Air Bearing	Air Bearing	Customer Supplied Bearings

Notes: All specifications are for reference only.

- (1) Encoder dependent
- (2) Vector control required. Encoder dependent
- (3) Acceleration is dependent on amount of mass attached
- (4) Accuracy and repeatability are referenced against a laser interferometer. Tighter tolerances are available.

- (5) Force @ 1 m/sec (40 in/sec)
- (6) Static force
- (7) Continuous and Peak Force for Steppers are the same



Page 27



Page 27



Page 27



Page 28



Page 28

Motor Series		Non-Commucated DC LMNM	Non-Commucated DC LMNC	DC Brushed Linear Servo LMBR	Polynoid Linear Motor LMPY	HyCore Linear Motor LMHS
Continuous Force	N Lbs	3 - 223 0.5 - 50	3 - 41 0.625 - 9	18.7 - 244.8 4.2 - 55	4 - 90 1 - 20	53 - 465 12 - 105
Peak Force @ 10% Duty	N Lbs	7 - 668 1.5 - 150	9 - 121 1.875 - 27	57.9 - 761.0 13 - 171	22 - 240 5 - 54	95 - 800 21 - 180
Acceleration	(3) m/s ² g's	98 10	98 10	49 5	9.8 1	29.4 3
Maximum Speed	m/s in/sec	1 40	0.5 20	1.9 75	2.3 90	1.5 60
Maximum Stroke	m in	0.05 2.0	0.013 0.5	3.2 11	Limited by end stops and support	Limited by end stops and support
Accuracy	(1) μm/ 300mm (4) in/ft	2.5 0.0001	5 0.0002	5.0 0.0002	N/A	5 0.0002
Repeatability	(1) μm (4) in	1 0.00004	1 0.00004	1 0.00004	N/A	1 0.00004
Positioning Type		Open or Closed Loop	Open or Closed Loop	Closed Loop	Open or Closed Loop	Closed Loop
Drive/Control		DC Servo Drive	DC Servo Drive	PWM Brushed Servo Drive	Direct Online or Inverter	3-Phase Brushless Control Hall-Less Commutation
Load Support		Jewel Sapphire or Ball Bushing	N/A	Customer Supplied Bearing	Integral Rulon Bearing	Customer Supplied Bearing

Cog-free Brushless Servo Motors

- › Standard and custom magnetic track lengths
- › Peak forces from 16N [3.6 Lbs] to 2300 N [517 Lbs]
- › High acceleration to 98m/s² [10g's]
- › High speeds to 10m/s [400 in/sec] with encoder resolutions ≥1 micron
- › Speeds to 2.5m/s [100 in/sec] with encoder resolutions ≤ 1 micron
- › High accuracy 2.5µm/300m [±0.0001 in/ft] (encoder dependent)
- › High repeatability 1µm [0.00004 in] (encoder dependent)
- › Unlimited stroke length
- › Independent multiple coil operation with overlapping trajectories
- › No metal-to-metal contact, virtually maintenance free
- › Modular magnet tracks



The cog free motor is designed for unlimited stroke servo applications that require smooth operation without magnetic force variation or “cogging”. A large range of motors are available to suit different applications. These motors are supplied in kit form to be integrated into your machine. They are used in closed loop servo systems and provide optimum performance. For higher continuous forces, air and water cooling options are available. Baldor's cog free motors are ideally suited for applications requiring high accuracy (with resolutions down to 0.1µm) and smooth movement.

The motors can be controlled from any of Baldor's 3 phase brushless drive family, including MicroFlex, FlexDrive-II, Flex+Drive-II and MintDrive-II. The motors are also compatible with the NextMove range of motion controllers for multi-axis position control. Baldor's cog free linear motors are nickel plated meeting ROHS compliance.

Baldor provides standard magnetic track lengths to optimize pricing for customers. These standards include: LTCF-C24, LTCF-E24, LTCF-F24; and LTCF-C40, LTCF-E40, LTCF-F40. Other track lengths are available as custom.

› Ordering Information

Primary (Forcer)

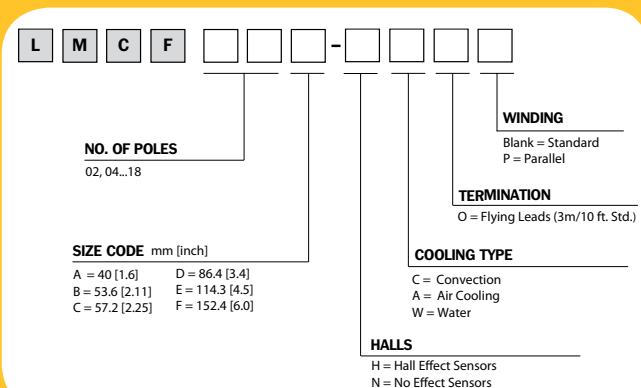

Secondary (Magnet Track)

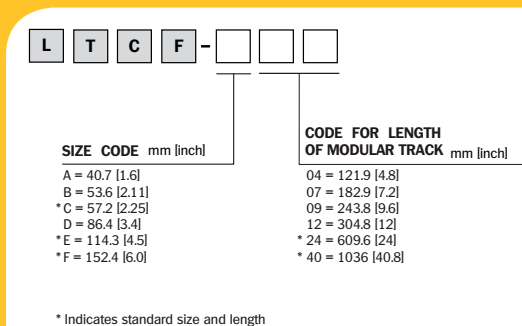

Cog-free Brushless Technical Data

Technical Data

Catalog Numbers	Continuous Force (1) - (2) - (3)		Continuous Current	Peak Force @ 10% Duty		Peak Current @ 10% Duty	Back-EMF Constant K_{emf} (ph-ph)	
	N	Lbs	Amps	N	Lbs	Amps	V/m/sec	V/in/sec
LMCF02A-HCO	5.3	1.2	1.7	16	3.6	5.1	3.1	0.08
LMCF02B-HCO	13.8	3.1	2.1	41.8	9.4	6.3	6.7	0.17
LMCF04B-HCO	27.8	6.2	2.1	83.3	18.7	6.3	13.2	0.34
(4) LMCF02C-HCO	29	6.5	1.9	86.8	19.5	5.7	15.2	0.39
(4) LMCF04C-HCO	58	13	1.9	173	39	5.7	30.4	0.77
(4) LMCF06C-HCO	87	19.5	1.9	260	58	5.7	45.6	1.16
(4) LMCF08C-HCO	116	26	1.9	347	78	5.7	60.9	1.55
LMCF02D-HCO	36.8	8.3	1.5	110	24	4.4	24.8	0.63
LMCF04D-HCO	73.6	16.5	1.5	220	49	4.4	49.6	1.26
LMCF06D-HCO	110	24.8	1.5	330	74	4.4	74.4	1.89
LMCF08D-HCO	147	33	1.5	440	99	4.4	99.3	2.52
LMCF10D-HCO	184	41.3	3.0	550	123	8.9	61.8	1.57
LMCF12D-HCO	220	49.6	3.0	660	148	8.9	74.2	1.88
(4) LMCF04E-HCO	124	28	1.6	372	84	4.7	79.9	2.03
(4) LMCF06E-HCO	185	42	3.1	556	125	9.2	59.7	1.52
(4) LMCF08E-HCO	251	56	3.1	753	169	9.2	82.0	2.08
(4) LMCF10E-HCO	314	70	3.1	942	212	9.2	102.5	2.60
(4) LMCF12E-HCO	377	85	3.1	1132	254	9.2	123.0	3.12
(4) LMCF14E-HCO	440	99	3.1	1318	294	9.2	143.5	3.64
(4) LMCF04F-HCO	191	43	2.6	578	130	7.8	74.4	1.89
(4) LMCF08F-HCO	387	87	2.6	1152	256	7.8	148.4	3.78
(4) LMCF12F-HCO	578	130	3.9	1726	338	11.6	148.4	3.77
(4) LMCF16F-HCO	771	173	5.2	2300	517	15.6	148.0	3.76

Notes: All specifications are for reference only.

Technical data at 75°C rise over 25°C ambient.

- (1) Addition of 254 x 254 x 25.4 mm [10 x 10 x 1 in] aluminum heat sink increases continuous force capability by 20% (along with 20% more current).
- (2) Addition of forced air cooling increases continuous force 12% (and 12% more current).
- (3) Liquid cooling option increases continuous forces by 25% and power dissipation by 50%. Available only on motors with D, E and F "size codes."
- (4) Standard Motor

Cog-free Brushless Motors Dimensions

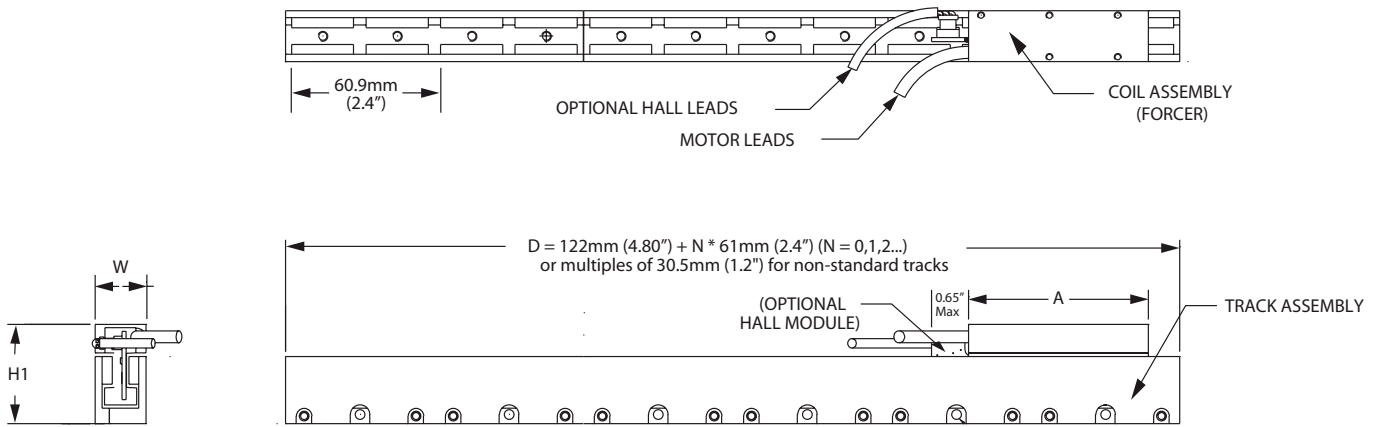

Track assemblies can be stacked for additional stroke lengths.

Forcer/Primary (Coil Assembly) - LMCF

Catalog Number	A		W		H1		Weight	
	mm	in	mm	in	mm	in	Kg	Lbs
Size A								
LMCF02A-HCO	73.7	2.90	20.8	0.82	40.64	1.60	0.08	0.17
Size B								
LMCF02B-HCO	73.7	2.90	20.83	0.82	53.59	2.11	0.11	0.25
LMCF04B-HCO	134.6	5.30	20.83	0.82	53.59	2.11	0.22	0.49
Size C								
LMCF02C-HCO	73.7	2.90	30.48	1.20	57.15	2.25	0.18	0.39
LMCF04C-HCO	134.6	5.30	30.48	1.20	57.15	2.25	0.32	0.70
LMCF06C-HCO	195.6	7.70	30.48	1.20	57.15	2.25	0.57	1.25
LMCF08C-HCO	256.5	10.10	30.48	1.20	57.15	2.25	0.75	1.64
Size D								
LMCF02D-HCO	73.7	2.90	34.29	1.35	86.31	3.40	0.35	0.76
LMCF04D-HCO	134.6	5.30	34.29	1.35	86.31	3.40	0.6	1.4
LMCF06D-HCO	195.6	7.70	34.29	1.35	86.31	3.40	0.9	2.0
LMCF08D-HCO	256.5	10.10	34.29	1.35	86.31	3.40	1.2	2.6
LMCF10D-HCO	317.5	12.50	34.29	1.35	86.31	3.40	1.5	3.2
LMCF12D-HCO	378.5	14.90	34.29	1.35	86.31	3.40	1.8	3.9
Size E								
LMCF04E-HCO	134.6	5.30	39.37	1.55	114.3	4.50	0.77	1.7
LMCF06E-HCO	195.6	7.70	39.37	1.55	114.3	4.50	1.1	2.5
LMCF08E-HCO	256.5	10.10	39.37	1.55	114.3	4.50	1.5	3.2
LMCF10E-HCO	317.5	12.50	39.37	1.55	114.3	4.50	1.8	4.0
LMCF12E-HCO	378.5	14.90	39.37	1.55	114.3	4.50	2.2	4.8
LMCF14E-HCO	439.4	17.30	39.37	1.55	114.3	4.50	2.5	5.6
Size F								
LMCF04F-HCO	156.2	5.30	44.0	1.73	152.4	6.00	1.65	3.6
LMCF08F-HCO	256.5	10.10	44.0	1.73	152.4	6.00	3.1	6.8
LMCF12F-HCO	378.5	14.90	44.0	1.73	152.4	6.00	4.5	9.9

Secondary (Track) - LTCF

Standard cog-free tracks include:	
610 mm (24inch)	1036 mm (40.8 inch)
LTCF-C24	LTCF-C40
LTCF-E24	LTCF-E40
LTCF-F24	LTCF-F40

Other track lengths are available as custom

Catalog Number	D	
	mm	in
LTCF-X04	122	4.8
LTCF-X07	183	7.2
LTCF-X09	244	9.6
LTCF-X12	305	12.0
LTCF-X24	610	24.0
LTCF-X40	1036	40.8

Catalog Number	Weight	
	Kg/m	Lb/in
LTCF-AXX	3.6	0.20
LTCF-BXX	5.5	0.31
LTCF-CXX	8.1	0.45
LTCF-DXX	11.6	0.65
LTCF-EXX	17.2	0.96
LTCF-FXX	34	1.90

NOTE: Min track length recommended = "A" dimension + 0.65 inch [1.65mm] + stroke [min 3 inch (76.2mm)]

Iron Core Brushless Servo Motor

- › Standard and custom magnetic track lengths
- › High peak force to 13813 N [3105 Lbs]
- › High continuous force to 5179 N [1164 Lbs]
- › High acceleration to over 10 g's
- › High speed to 8 m/s [320 in/sec] with encoder resolution ≥ 1 micron
- › High speed to 4 m/s [160 in/sec] with encoder resolution ≥ 1 micron
- › High accuracy ± 0.0001 2.5 μ m/300mm [in/ft] encoder dependent
- › High repeatability $\pm 1\mu$ m [0.00004 in] encoder dependent
- › Unlimited travel stroke length
- › Payloads to 100 Kg (220 Lbs)
- › Multiple coil independent operation with overlapping trajectories
- › Non-contact, virtually maintenance free

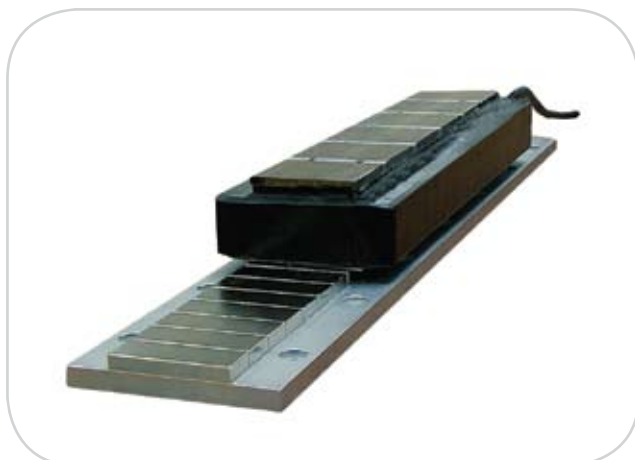

Linear Iron Core Brushless Servo Motors are designed for unlimited travel stroke positioning applications with high thrust force, high speed and acceleration, with optimal static and dynamic performance. The motors are designed to integrate easily with equipment, providing closed-loop servo with a high degree of positioning accuracy and repeatability.

Linear iron core brushless servomotors consist of a magnet track and a coil assembly supported by customer-supplied bearing system. For higher continuous forces, air and water cooling options are available.

The magnet track is comprised of multi-pole alternating polarity permanent magnets bonded on a nickel cold-rolled steel plate. The coil assembly consists of a high magnetic property

laminated steel assembly encapsulated in thermally conductive epoxy. Hall effect sensors are used to provide feedback. Custom designs with other sensors are also available.

The motors can be controlled from any of Baldor's 3 phase brushless drive family, including MicroFlex, FlexDrive-II, Flex+Drive-II and MintDrive-II. The motors are also compatible with the NextMove range of motion controllers for multi-axis position control.

Baldor provides standard magnetic track lengths to optimize pricing for customers. These standard tracks include: LTIC-A24, LTIC-C24, LTIC-E24; and LTIC-A40, LTIC-C40, LTIC-E40. Other track lengths are available as custom.

› Ordering Information

Primary (Forcer)

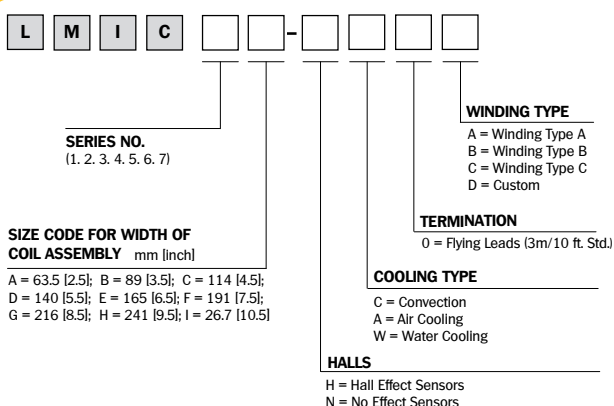

Secondary (Magnet Track)

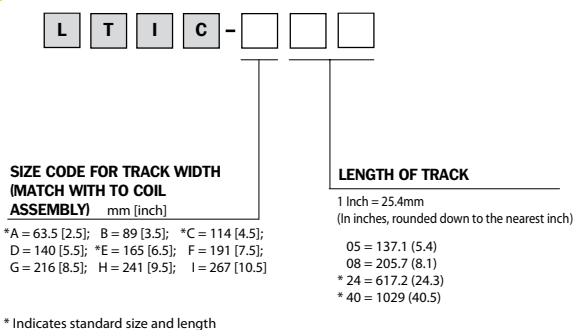

Iron Core Brushless Technical Data

› Technical Data

Catalog Number	Continuous Force (1) - (2) - (3)		Continuous Current Amps	Peak Force @ 10% Duty		Peak Current @ 10% Duty Amps	Attractive Force		Back-EMF Constant K_{emf} (ph-ph)	
	N	Lbs		N	Lbs		N	Lbs	V/m/sec	V/in/sec
(4) LMIC1A-S-HCOA	80	18	4	213	48	12	894	201	20	0.5
(4) LMIC1A-S-HCOB	80	18	8	213	48	24	894	201	10	0.25
(4) LMIC1C-S-HCOA	244	55	4	654	147	12	2682	603	61	1.6
(4) LMIC1C-S-HCOB	244	55	8	654	147	24	2682	603	30.5	0.8
LMIC2B-S-HCOA	329	74	4	877	194	12	3579	804	82	2.1
LMIC2B-S-HCOB	329	74	8	877	197	24	3579	804	41	1.0
(4) LMIC2C-S-HCOA	489	110	4	1305	293	12	5364	1206	122	3.1
(4) LMIC2C-S-HCOB	489	110	8	1305	293	24	5364	1206	61	1.6
(4) LMIC2E-S-HCOA	818	184	4	2183	490	12	8941	2010	205	5.2
(4) LMIC2E-S-HCOB	818	184	8	2183	490	24	8941	2010	102	2.6
LMIC3D-S-HCOA	983	221	4	2622	589	12	10729	2412	246	6.2
LMIC3D-S-HCOB	983	221	8	2622	589	24	10729	2412	123	3.1
LMIC3D-S-HCOC	983	221	16	2622	589	48	10729	2412	61	1.6
(4) LMIC3E-S-HCOA	1232	277	4	3286	739	12	13411	3015	308	7.8
(4) LMIC3E-S-HCOB	1232	277	8	3286	739	24	13411	3015	154	3.9
(4) LMIC3E-S-HCOC	1232	277	16	3286	739	48	13411	3015	77	2.0
(4) LMIC4E-S-HCOA	1641	369	4	4377	984	12	17882	4020	410	10.4
(4) LMIC4E-S-HCOB	1641	369	8	4377	984	24	17882	4020	205	5.2
(4) LMIC4E-S-HCOC	1641	369	16	4377	984	48	17882	4020	102	2.6
LMIC5F-S-HCOA	2465	554	4	6574	1478	12	26823	6030	616	15.6
LMIC5F-S-HCOB	2465	554	8	6574	1478	24	26823	6030	308	7.8
LMIC5F-S-HCOC	2465	554	16	6574	1478	48	26823	6030	154	3.9
LMIC6G-S-HCOA	3451	776	4	9203	2069	12	37552	8442	864	21.9
LMIC6G-S-HCOB	3451	776	8	9203	2069	24	37552	8442	432	12.0
LMIC6G-S-HCOC	3451	776	16	9203	2069	48	37552	8442	216	6.0
LMIC6I-S-HCOA	4439	998	4	11838	2661	12	48281	10854	1100	28.2
LMIC6I-S-HCOB	4439	998	8	11838	2661	24	48281	10854	555	14.1
LMIC6I-S-HCOC	4439	998	16	11838	2661	48	48281	10854	277	7.0
LMIC7I-S-HCOA	5179	1164	4	13813	3105	12	56326	12663	1294	32.9
LMIC7I-S-HCOB	5179	1164	8	13813	3105	24	56326	12663	647	16.4
LMIC7I-S-HCOC	5179	1164	16	13813	3105	48	56326	12663	324	8.2

Notes: All specifications are for reference only.

Technical data at 75°C rise over 25°C ambient.

(1) Addition of 254 x 254 x 25.4 mm [10 x 10 x 1 in] aluminum heat sink increases continuous force capability by 20% (along with 20% more current).

(2) Addition of forced air cooling increases continuous force 12% (and 12% more current).

(3) Liquid cooling option increases continuous forces by 25% and power dissipation by 50%. Available only on motors with D, E and F "size codes."

(4) Standard Motor

Iron Core Brushless Motor Performance Curves

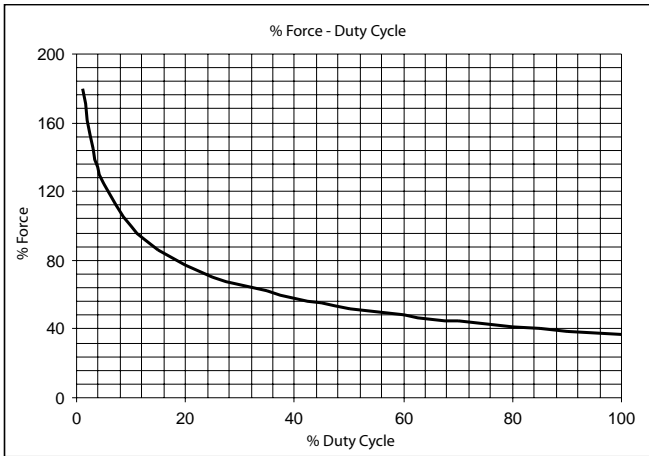

Figure 1: % Force versus % Duty Cycle

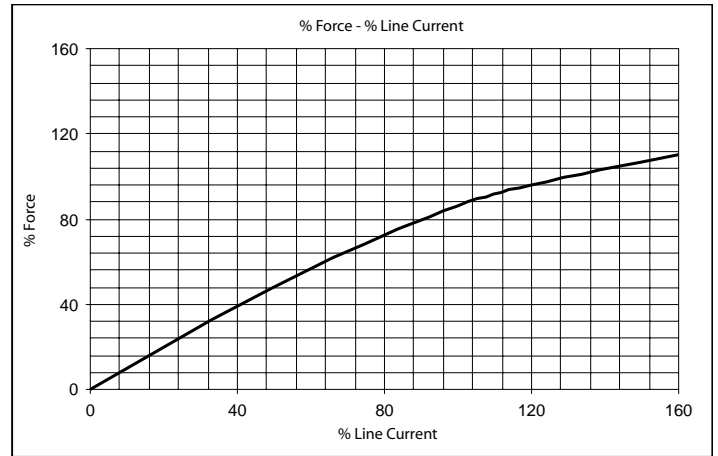

Figure 2: % Force versus % Line Current

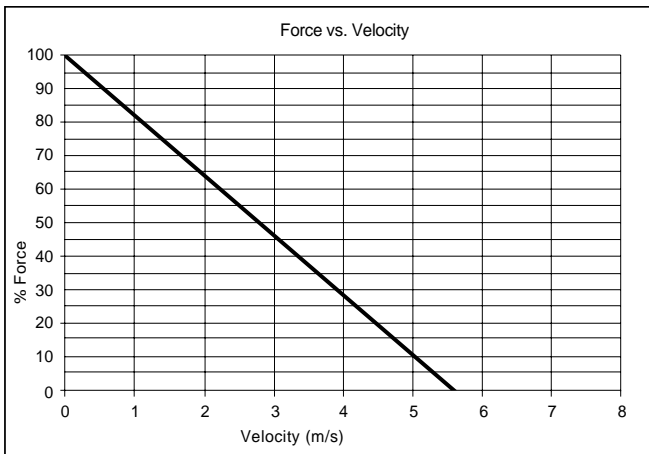

Figure 3: % Output Force versus Velocity

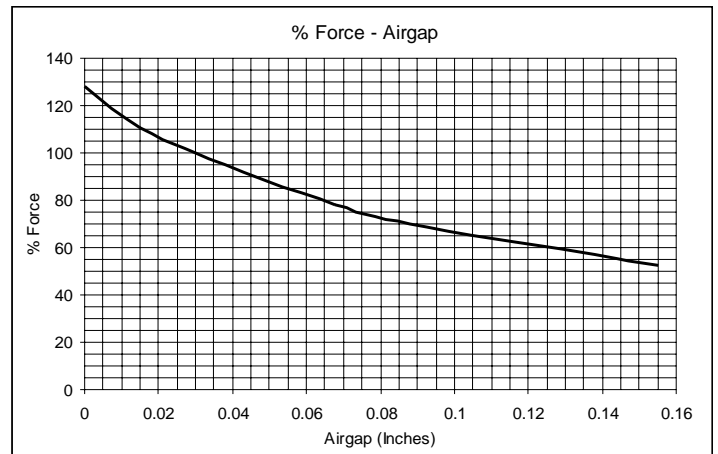
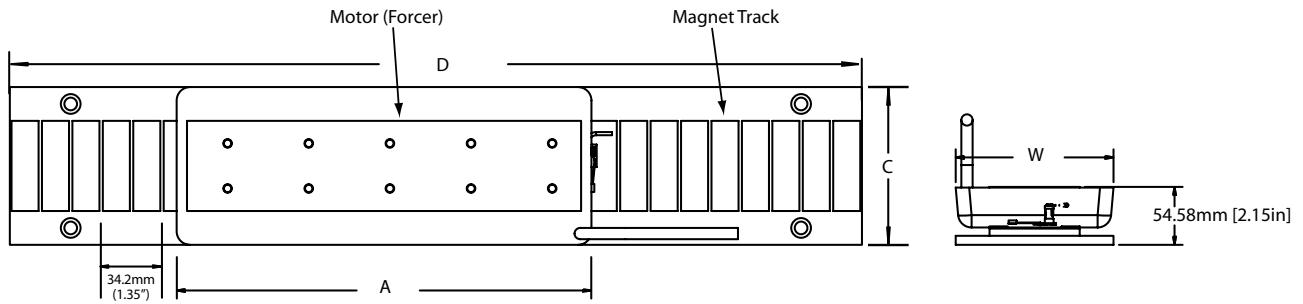

Figure 4: % Output Force versus Airgap

Iron Core Brushless Motor Dimensions



Track assemblies can be stacked for longer stroke lengths

Secondary (Magnetic Track) - LTIC

Standard tracks include:	
617 mm (24.3 inch)	1029 mm (40.5 inch)
LTIC-AS24	LTIC-AS40
LTIC-CS24	LTIC-CS40
LTIC-ES24	LTIC-ES40
Other tracks available as custom	

Forcer/Primary (Coil Assembly)

Catalog Number	A		W		Weight	
	mm	in	mm	in	Kg	lbs
LMIC1A-S-HCOx	162.6	6.4	63.5	2.5	1.2	2.7
LMIC1C-S-HCOx	162.6	6.4	114	4.5	3.4	7.4
LMIC2B-S-HCOx	299.7	11.8	89	3.5	4.5	10.0
LMIC2C-S-HCOx	299.7	11.8	114	4.5	6.7	14.7
LMIC2E-S-HCOx	299.7	11.8	165	6.5	11.2	24.7
LMIC3D-S-HCOx	436.9	17.2	140	5.5	13.6	30
LMIC3E-S-HCOx	436.9	17.2	165	6.5	16.8	37
LMIC4E-S-HCOxx	574.0	22.6	165	6.5	22.4	49
LMIC5F-S-HCOx	711.2	28.0	191	7.5	33.3	73
LMIC6G-S-HCOx	848.4	33.4	267	10.5	46.8	103
LMIC7I-S-HCOx	985.2	38.8	267	10.5	72	158

Catalog Number	C		D	
	mm	in	mm	in
LTIC-AS05	63.5	2.5	137.2	5.4
LTIC-AS08	63.5	2.5	205.7	8.1
LTIC-AS24	63.5	2.4	617.2	24.3
LTIC-AS40	63.5	2.4	1010.9	39.8
LTIC-BS05	89	3.5	137.2	5.4
LTIC-BS08	89	3.5	205.7	8.1
LTIC-BS24	89	3.5	617.2	24.3
LTIC-CS05	114	4.5	137.2	5.4
LTIC-CS08	114	4.5	205.7	8.1
LTIC-CS24	114	4.5	617.2	24.3
LTIC-CS40	114	4.5	1010.9	39.8
LTIC-DS05	140	5.5	137.2	5.4
LTIC-DS08	140	5.5	205.7	8.1
LTIC-DS24	140	5.5	617.2	24.3
LTIC-ES05	165	6.5	137.2	5.4
LTIC-ES08	165	6.5	205.7	8.1
LTIC-ES24	165	6.5	617.2	24.3
LTIC-ES40	165	6.5	1010.9	39.8
LTIC-FS05	191	7.5	137.2	5.4
LTIC-FS08	191	7.5	205.7	8.1
LTIC-FS24	191	7.5	617.2	24.3
LTIC-GS05	216	8.5	137.2	5.4
LTIC-GS08	216	8.5	205.7	8.1
LTIC-GS24	216	8.5	617.2	24.3
LTIC-IS05	267	10.5	137.2	5.4
LTIC-IS08	267	10.5	205.7	8.1
LTIC-IS24	267	10.5	617.2	24.3

Secondary (Magnetic Track)

Catalog Number	Weight	
	Kg/m	lb/in
LTIC-AXX	6.3	0.4
LTIC-BXX	10.7	0.6
LTIC-CXX	15.2	0.9
LTIC-DXX	18.8	1.1
LTIC-EXX	22.4	1.3
LTIC-FXX	26	1.5
LTIC-GXX	30.4	1.7
LTIC-HXX	36.7	2.1
LTIC-IXX	43	2.4

NOTE: A lower profile motor is also available. Please contact Baldor for details.

NOTE: Min track length recommended = "A" Dimension + Stroke [min 2 inches (50.8 mm)]

Single-Axis Stepper Motor

- › Cost effective linear motion
- › Open loop - no tuning or encoder are necessary
- › Use with microstepping drive
- › Multiple forcers with overlapping trajectories on a single platen
- › Ceiling or wall mountable
- › 9.8 m/s² [1g] typical accelerations @ 1 m/s [40 lps]
- › Acceleration up to 59 m/s² [6g] under 0.25 m/s [10 lps]
- › Forces to 222.4N [50 Lbs.]
- › High repeatability 10 μm [0.0004 in]
- › Unlimited travel
- › Rapid settling times
- › Roller bearings on 0600 and 1300 series. High stiffness air bearings on 2000 and 2500 series

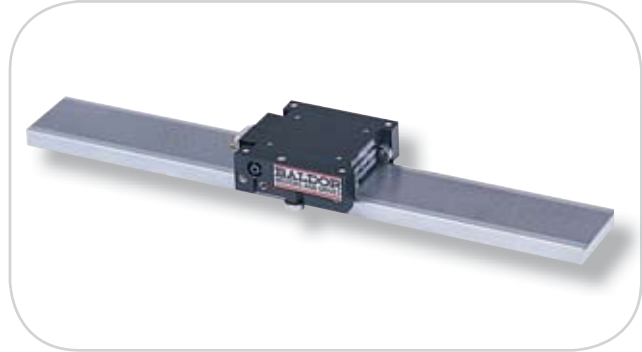

The open-loop linear stepper motor provides the most economical linear motor positioning package. It is possible to stack the single axis linear stepper to provide multiple axes. Packages are made up of two components: a moving forcer (with bearings) and a stationary platen.

The forcer is made of two laminated steel cores precisely slotted with teeth and a single permanent magnet. The coil is inserted into the laminated assembly with leads provided at the beginnings and ends of the coils. Two interconnected coils result in a 2-phase motor, and four interconnected coils result in a 4-phase motor. The laminated assembly is encapsulated in an aluminum housing. The forcer is available in different sizes, depending on the application's force requirements.

The platen has a photo-chemically etched teeth on a steel bar filled with epoxy, ground and nickel plated. Standard mounting holes are provided on forcer and platen. Upon special request platens can be stacked end-to-end for unlimited lengths. The magnetic-attractive force between the forcer and platen is used as a preload for the bearing system. The magnetic - attractive force enables the motor to be run in an inverted position. The platen to forcer air gap is maintained by the integral bearing system. The customer must bring power to the forcer with an umbilical cable.

› Ordering Information

Primary (Forcer)

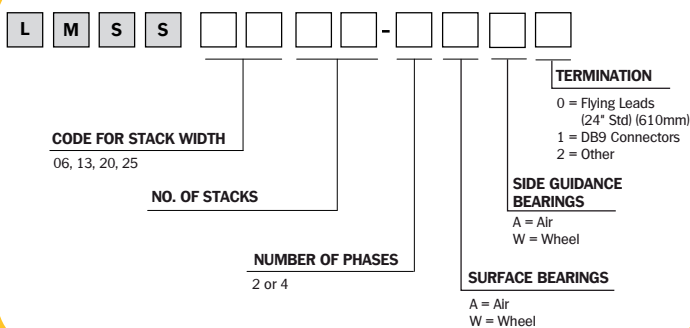

Secondary (Track)

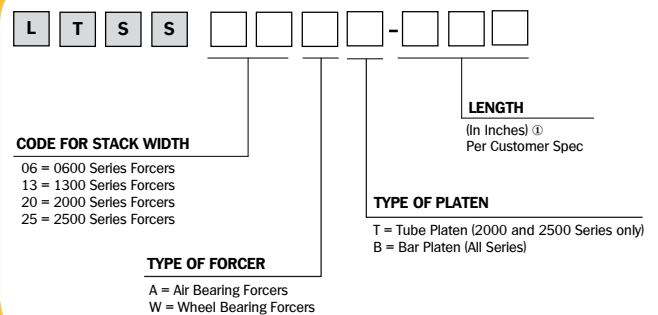

Single-Axis Stepper Motor Technical Data

Performance Curves

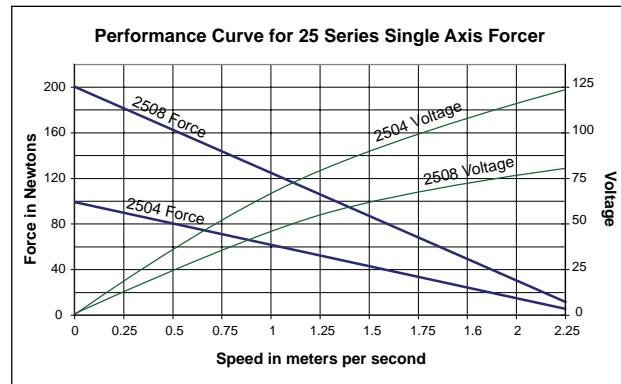
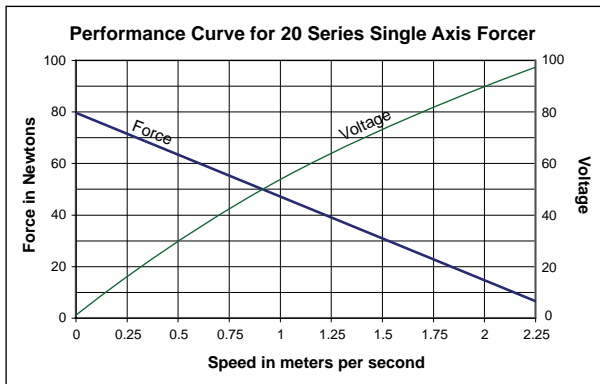
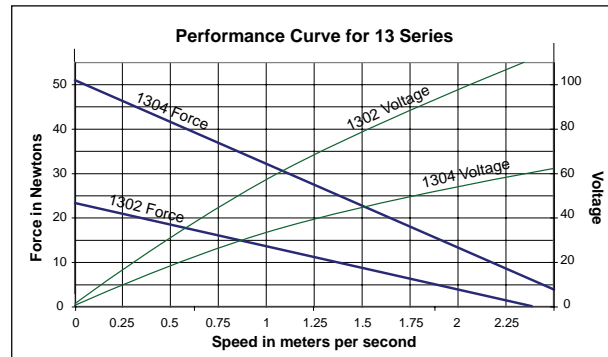
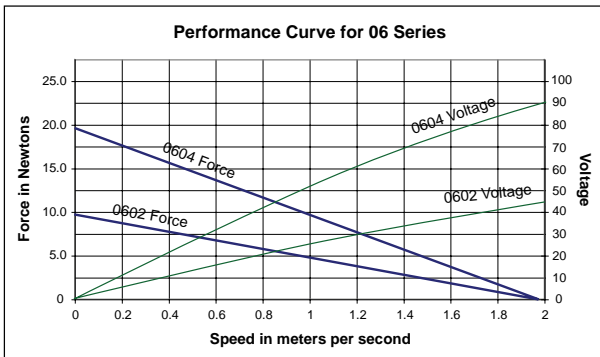

Technical Data

2-phase Single Axis Forcers

Catalog Number	No. of phases	Static Force		Force @ 40 inches/sec		Inductance (Coil)	Resistance	Amps/Phase		Weight		Bearing Type	Air Bearing Requirement		Attractive Force	
		N	Lbs	N	Lbs			mH	Ohms	Amps	Kg		Lbs	-	CFM	L/min
LMSS0602-2WW0	2	10	2.2	5	1.2	1.2	1.5	1.5	0.18	0.4	Wheel	NA	NA	72	16	
LMSS0604-2WW0	2	20	4.4	11	2.4	2.3	3.0	1.5	0.27	0.6	Wheel	NA	NA	140	32	
LMSS1302-2WW1	2	23	5.1	12	2.8	2.6	2.2	2	0.36	0.8	Wheel	NA	NA	200	45	
LMSS1304-2AW1	2	50	11.3	28	6.2	1.3	1.1	4	0.41	0.9	Air	7	0.25	400	90	
LMSS2004-2AW1	2	80	18.0	44	9.9	1.6	1.6	4	0.50	1.1	Air	25	0.90	665	150	
LMSS2504-2AW1	2	100	22.5	55	12.4	2.2	2.2	4	0.55	1.2	Air	8	0.30	845	190	
LMSS2508-2AW1	2	200	45.0	110	24.8	4.0	3.7	8	1.09	2.4	Air	10	0.35	1690	380	

NOTES:

- (1) Four phase is available with the same force ratings and physical size except LMSS0602 and LMSS1302
 - (2) Air bearing units use a side ball bearing for lateral guidance as standard. Side air bearings are optional and requires using a tube platen. Repeatability = 10um (+0.0004 in). Resolution= 2.5um (+0.0001 in), Cyclic error= ±0.0002 in ±5µm (±0.0002 in) *dependent on drive electronics and system implementation Wheel Bearing Airgap= 0.0015 in (38µm), Air Bearing Airgap= 0.0008 in (20µm), Air Pressure= 60-80 psi (4.1-5.5 bar) with a 3 micron filter.
- All specifications are for reference only

Single-Axis Stepper Forcer Dimensions

Model 0602

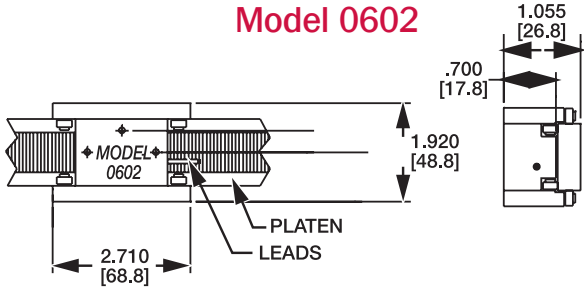

Model 0604

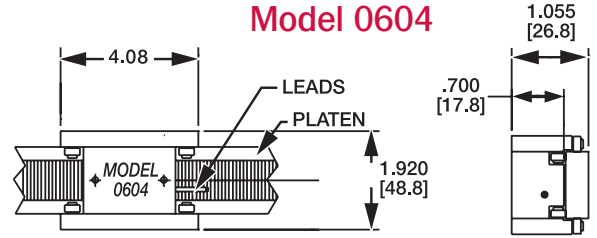

Model 1302

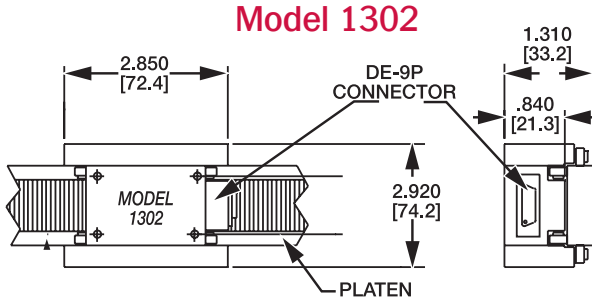

Model 1304

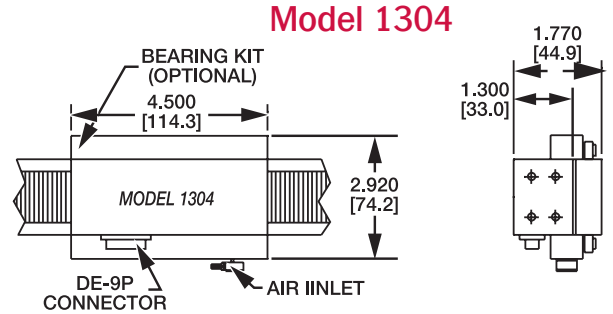

Model 2504

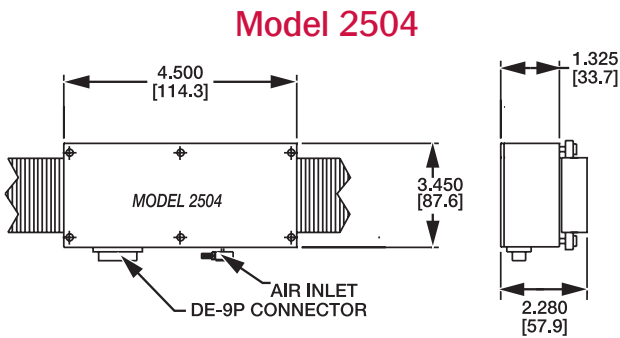

Model 2508

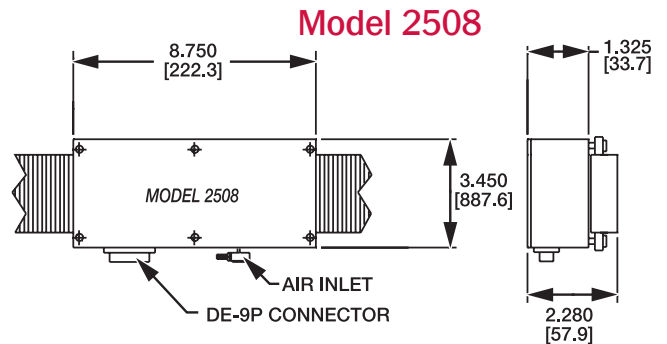

Model 2004

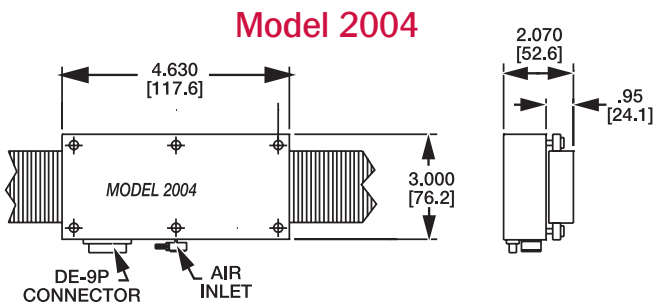

Single Axis Stepper Motor Platen Dimensions

SERIES
0600 and 1300

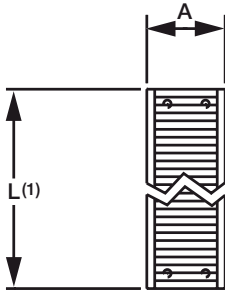

BAR PLATEN

SERIES
2000

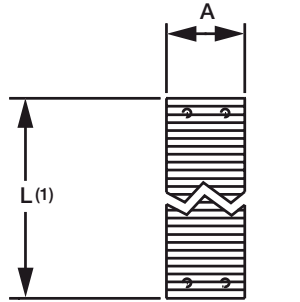

BAR PLATEN

SERIES
2000 and 2500

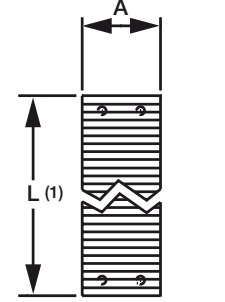

TUBE PLATEN

LTSS Series Platen Dimensions

Series	Catalog Number	A		T		Weight	
		mm	in	mm	in	kg/m	Lbs/in
0600 Bar	LTSS06WB-XXX	30.7	1.21	8.9	0.35	2.11	0.118
1300 Bar	LTSS13XB-XXX	49.8	1.96	11.9	0.468	4.72	0.264
2000 Bar	LTSS20XB-XXX	49.8	1.96	11.9	0.468	4.72	0.264
2000 Tube	LTSS20XT-XXX	49.8	1.96	24.4	1.035	3.94	0.193
2500 Bar	LTSS25XB-XXX	76.2	3.0	24.4	0.96	12.15	0.680
2500 Tube	LTSS25XT-XXX	76.2	3.0	24.4	1.035	5.06	0.283

NOTE:

- (1) Platen will be cut to length (L) per customer specification.
- (2) Bottom mounting holes pattern is as shown.
- (3) Bar platen is parallel to less than 0.0005 inch/12 ft to attain this flatness the bar must be mounted to a flat customer supplied surface
- (4) XXX = Length in inches (1 inch = 25.4 mm)

Dual-Axis Stepper HoneyComb Series

- › Two-axis motion in a single plane - provides lowest cost dual-axis positioning stage
- › Acceleration to 49 m/s² [5g]
- › High repeatability 2 μm [0.0001 in]
- › Flatness = 14 μm/300 mm [0.0005 in/ft]
- › Resolution = Full Step / Number of micro-steps
 - 2-phase min. 5 μm [0.0002 in]
 - 4-phase min. 2.5 μm [0.0001 in]
- › Platens up to 750 x 1500 mm (29.5 x 59 in)
- › Lighter weight – 70% Lighter than comparable models
- › High speed capability – Up to 1.5 m/s (60 in/s)
- › Multiple forcers with overlapping trajectories on a single platen
- › High stiffness air bearings
- › Mount face up or inverted.



The open-loop linear stepper motor provides the most economical linear motor positioning package. The compact dual-axis stepper motor provides travel along two axes in a single plane. The dual axis package is comprised of two components: a moving forcer (with air bearings) and a stationary platen.

The forcer is made of four single-axis coil assemblies. Two of the forcer assemblies are mounted in series to provide a thrust in the X direction and the other two are mounted orthogonal (at 90 deg. to the first two assemblies) to provide thrust in the Y direction. The forcer assemblies are encapsulated in a hard anodized aluminum housing. The motor's surface is lapped to provide a flat surface for the air bearing with the floating height of the air bearing being less than 25 μm [0.0008 in]. The forcer is available in eight sizes, depending on the application's force requirements.

The platen consists of new composite material to maximize strength and stiffness. Standard mounting holes are provided and the platen is available in usable sizes up to 0.75 x 1.5 m [29.5 x 59]. Preload for the bearing system is provided by the magnetic-attractive force between the forcer and the platen. The customer must bring power to the forcer with a cable, and provide the bearing air supply.

› Ordering Information

Primary (Forcer)

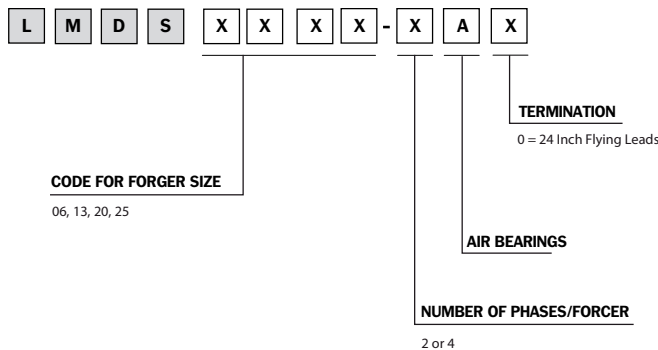

Secondary (Platen)

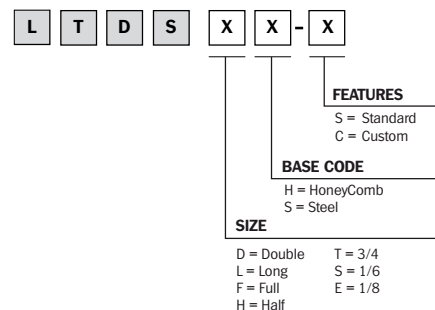

Dual-Axis Stepper Motor Technical Data

› Performance Curves

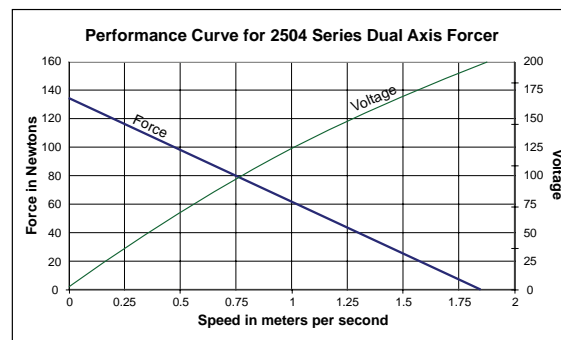
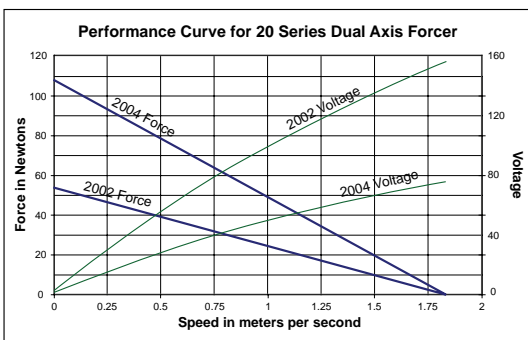
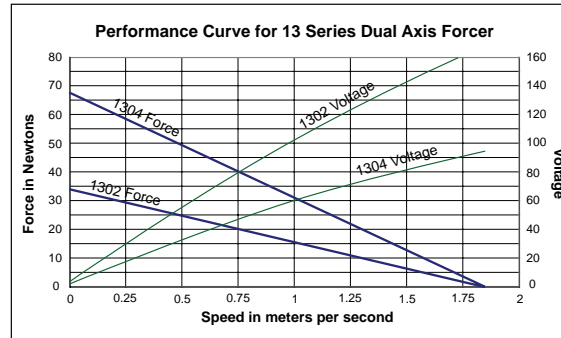
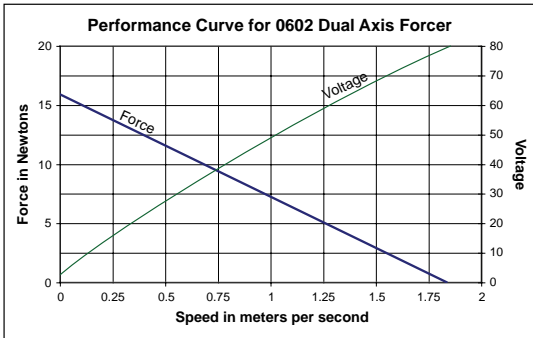

› Technical Data

2-phase Dual Axis Forcers

Catalog Number	No. of phases (1)	Static Force		Force @ 40 inches/sec		Inductance (Coil)	Resistance/Phase	Amps/Phase	Weight		Air Bearing Requirement		Attractive Force	
		N	Lbs	N	Lbs				mH	ohms	Amps	kg	Lbs	L/min
LMDS0602-2A0	2	15	3.3	7	1.5	3.3	3.1	2	0.36	0.8	6	0.20	160	36
LMDS1302-2A0	2	33	7.4	15	3.4	5.2	4.2	2	0.50	1.1	8	0.27	400	90
LMDS2002-2A0	2(1)	54	12.1	25	5.5	1.7	1.7	2	0.73	1.6	12	0.42	710	160
LMDS1304-2A0	2(1)	67	15.0	30	6.8	2.9	2.2	4	1.45	3.2	18	0.64	890	200
LMDS2004-2A0	2(1)	110	24.5	48	10.8	3.3	3.2	4	2.05	4.5	22	0.78	1420	320
LMDS2504-2A0	2(1)	134	30.0	60	13.5	4.4	3.8	4	2.32	5.1	25	0.90	1780	400

NOTES:

- (1) Four phase is available with the same force ratings and physical size. Typically, a 4-phase motor has twice the resolution as a 2-phase. The maximum 4-phase resolution is about $\pm 2 \mu\text{m}$.
 - › Bi-directional repeatability = $\pm 5 \mu\text{m}$ (± 0.0002 in). Unidirectional repeatability better than .0001 inch.
 - › Resolution = $2.5 \mu\text{m}$ (0.0002 in), Cyclic error = $\pm 5 \mu\text{m}$ (± 0.0002 in) independent on drive electronics and system implementation
 - › Standard Pitch 1.016 mm (0.04 in), Optional Pitch 0.508 mm (0.02 in)
 - › Air Bearing Airgap = $20 \mu\text{m}$ (0.0008 in), Air Pressure = 4-5.5 bar (60-80 psi) with a 5 micron filter.
 - › All specifications are for reference only.

Dual-Axis Stepper Motor Dimensions

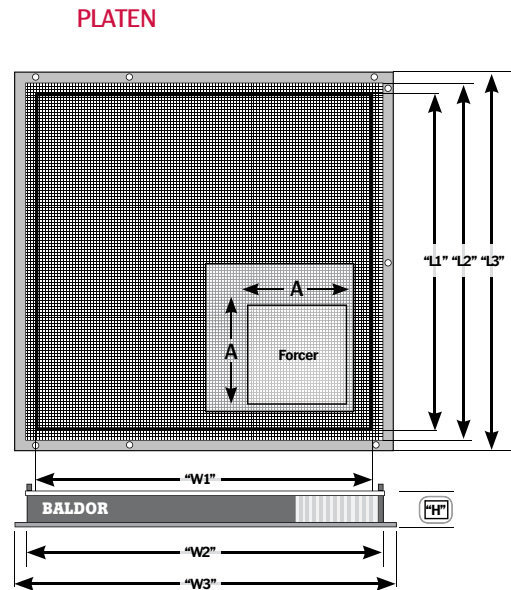
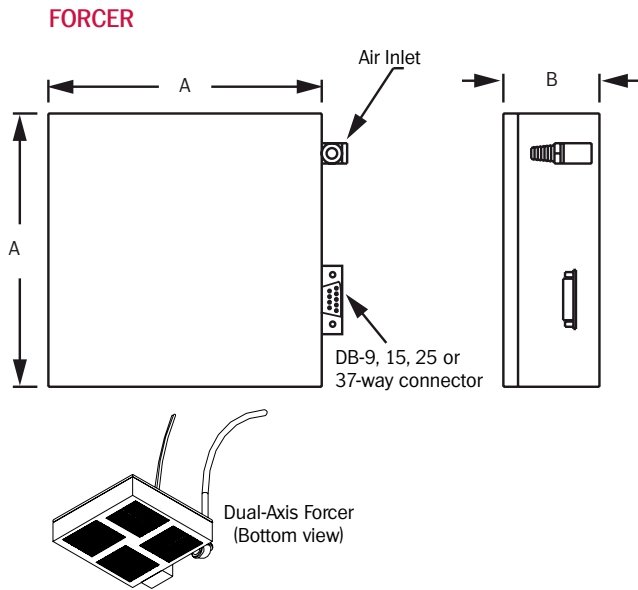

FORCER

Catalog Number	A		B		Weight	
	mm	in	mm	in	Kg	Lbs
LMDS - 0602	80.0	3.15	28	1.1	0.36	0.8
LMDS - 1302	96.5	3.80	30	1.2	0.50	1.1
LMDS - 2002	120.7	4.75	30	1.2	0.73	1.6
LMDS - 1304	149.4	5.88	30	1.2	1.45	3.2
LMDS - 2004	165.1	6.50	30	1.2	2.05	4.5
LMDS - 2504	177.8	7.0	36.8	1.45	2.32	5.1

PLATEN

Catalog Number		LTDS-EH-S	LTDS-SH-S	LTDS-TH-S	LTDS-HH-S	LTDS-FH-S	LTDS-LH-S	LTDS-DH-S
Usable Width "W1"	mm	375	375	500	750	750	750	750
	inch	14.8	14.8	19.7	29.5	29.5	29.5	29.5
Usable Length "L1"	mm	375	500	750	750	1000	1125	1500
	inch	14.8	19.7	29.5	29.5	39.4	44.3	59.0
Width "W2"	mm	410	410	535	785	785	785	785
	inch	16.1	16.1	21.1	30.9	30.9	30.9	30.9
Length "L2"	mm	410	535	785	785	1035	1160	1535
	inch	16.1	21.1	30.9	30.9	40.7	45.7	60.4
Overall Width "W3"	mm	445	445	570	820	820	820	820
	inch	17.5	17.5	22.4	32.3	32.3	32.3	32.3
Overall Length "L3"	mm	445	570	820	820	1070	1195	1570
	inch	17.5	22.4	32.3	32.3	42.1	47.0	61.8
Height	mm	28.4	28.4	28.4	28.4	28.4	46.2	46.2
	inch	1.1	1.1	1.1	1.1	1.1	1.8	1.8
Total Platen mass / weight	Kilo	9.5	12.2	22.2	31.7	41.2	47.1	61.8
	Lbs	21.0	26.8	48.9	69.9	90.9	104.0	136.3

NOTES:

(1) RoHS compliant

(2) Flatness: Top: 14 microns/300mm (± 0.0005 inch/foot typical)

AC Linear Induction Motor

- › High forces to 2,225 N [500 Lbs.] at 15% duty cycle
- › Acceleration to 9.8 m/s² [1g]
- › Speeds to 6.85 m/s [270 in/sec] at 60 Hz
- › Higher speeds at higher frequencies
- › Moving primary or secondary available
- › Non-contact, virtually maintenance free
- › Heavy payloads
- › Unlimited stroke length
- › Use with: Single or three-phase AC line voltage, 50 or 60 Hz. Single-phase requires use of external capacitor
- › Positioning possible with feedback system



The Linear Induction Motor is designed for high force, long-stroke applications, such as material handling, people movers, conveyors and sliding gates.

The single sided Linear Induction Motor consists of a primary coil assembly and a secondary called a reaction plate. The coil assembly is comprised of steel laminations and phase windings with a thermal sensor encapsulated in epoxy. The customer supplied reaction plate is made of 3.2 mm (1/8 inch) thick aluminum or copper plate bonded to a 6.35 mm (1/4 inch) thick

cold rolled steel. The aluminum faces the coil assembly. The width of a reaction plate must be equal to the width of the coil assembly. A customer supplied bearing system is used to maintain the 3.2 mm (1/8 inch) air gap between the coil and reaction plate over the length of the stroke. Forced cooling can be used to increase the continuous rating of the motor.

The linear induction motor can be controlled direct on line or using an inverter or vector drive such as Baldor's range of H2 drives.

› Ordering Information

Primary (Forcer)

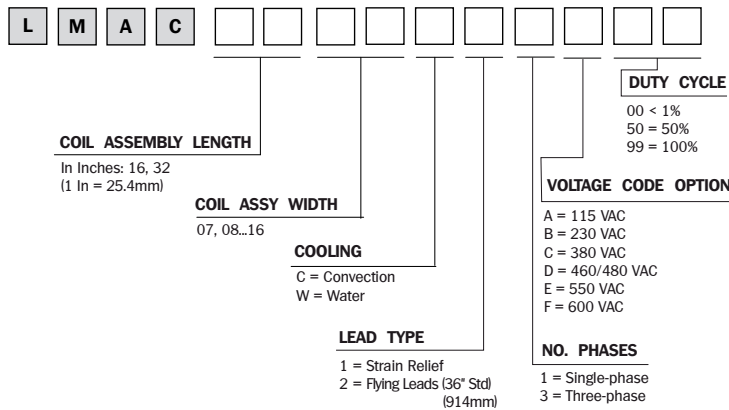

AC Linear Induction Motor Technical Data

› Technical Data

Catalog Number	Force Continuous (@100% Duty Cycle)		Current Continuous 460VAC 3Ph	Weight	
	N	Lbs	Amps	Kg	Lbs
LMAC1607C23D99	62	14	2.3	20	44
LMAC1608C23D99	80	18	2.9	25	55
LMAC1609C23D99	106	24	3.7	31	68
LMAC1610C23D99	124	28	4.2	36.2	80
LMAC1611C23D99	142	32	5.0	41.6	92
LMAC1612C23D99	169	38	5.7	47.5	105
LMAC1613C23D99	186	42	6.1	52.9	117
LMAC1614C23D99	204	46	7.3	57.9	128
LMAC1615C23D99	231	52	7.6	63.3	140
LMAC1616C23D99	258	58	8.0	68.8	152
LMAC3207C23D99	124	28	4.4	39.8	88
LMAC3208C23D99	160	36	5.6	49.8	110
LMAC3209C23D99	195	44	6.8	61.5	136
LMAC3210C23D99	231	52	8.0	72.4	160
LMAC3211C23D99	275	62	9.5	83.3	184
LMAC3212C23D99	320	72	11.0	95.0	210
LMAC3213C23D99	347	78	11.5	105.9	234
LMAC3214C23D99	400	90	13.5	115.8	256
LMAC3215C23D99	427	96	14.1	126.7	280
LMAC3216C23D99	445	100	14.7	137.6	304

AC Linear Induction Motor Technical Data

› Technical Data

Catalog Number	Force @ 15% Duty Cycle		Current @ 15% Duty Cycle 460VAC 3Ph	Weight	
	N	Lbs	Amps	Kg	Lbs
LMAC1607C23D15	311	70	11.5	20	44
LMAC1608C23D15	400	90	14.5	25	55
LMAC1609C23D15	534	120	18.5	31	68
LMAC1610C23D15	622	140	21	36.2	80
LMAC1611C23D15	711	160	25	41.6	92
LMAC1612C23D15	845	190	28.5	47.5	105
LMAC1613C23D15	934	210	30.5	52.9	117
LMAC1614C23D15	1023	230	36.5	57.9	128
LMAC1615C23D15	1156	260	38	63.3	140
LMAC1616C23D15	1289	290	40	68.8	152
LMAC3207C23D15	622	140	22	39.8	88
LMAC3208C23D15	800	180	28	49.8	110
LMAC3209C23D15	978	220	34	61.5	136
LMAC3210C23D15	1156	260	40	72.4	160
LMAC3211C23D15	1378	310	47.5	83.3	184
LMAC3212C23D15	1600	360	55	95.0	210
LMAC3213C23D15	1434	390	57.5	105.9	234
LMAC3214C23D15	2000	450	67.5	115.8	256
LMAC3215C23D15	2135	480	70.5	126.7	280
LMAC3216C23D15	2224	500	73.5	137.6	304

AC Linear Induction Motor Curves

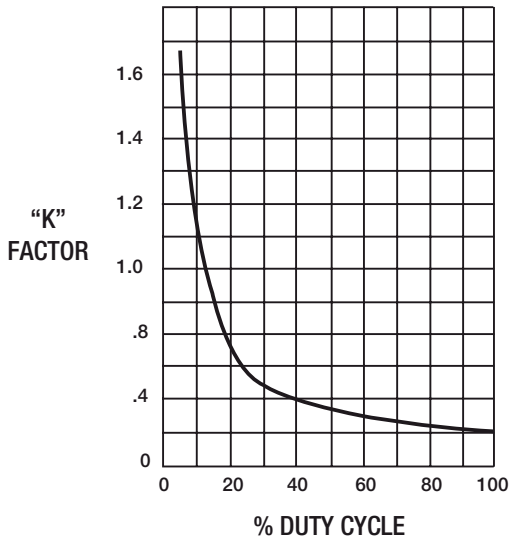

Figure 1

The force and current ratings shown in the performance table are based on 460VAC, three phase, 60 Hz input at a 15% duty cycle and a 1/8 inch (3.175 mm) airgap. To select a motor at other duty cycles, divide the required force by the duty cycle K factor rating on the curve corresponding to the required duty cycle. Select the closest equivalent or next higher rating from the performance table.

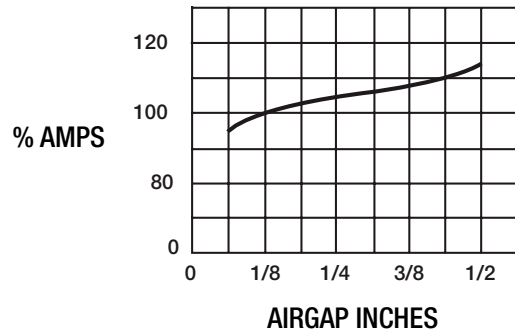

Figure 3

Provides the % motor current versus the motor airgap in inches.

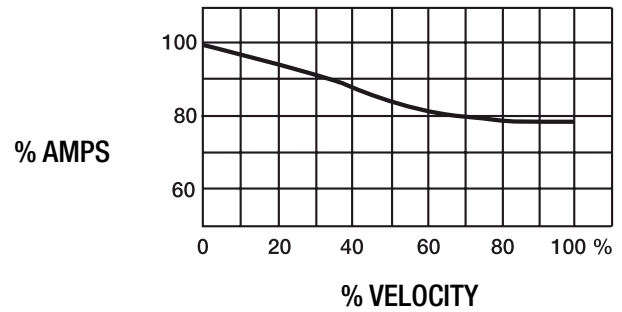

Figure 4

Provides the % motor current vs. % motor speed.

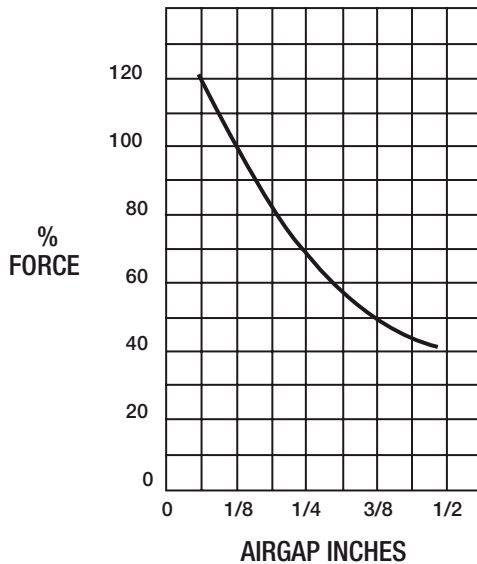

Figure 2

Provides the % force output versus the motor airgap in inches

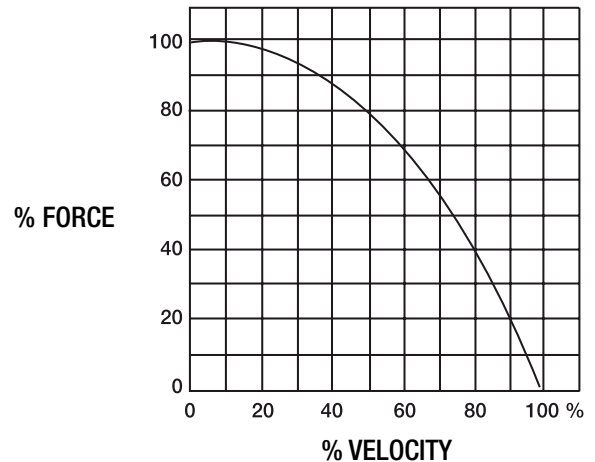
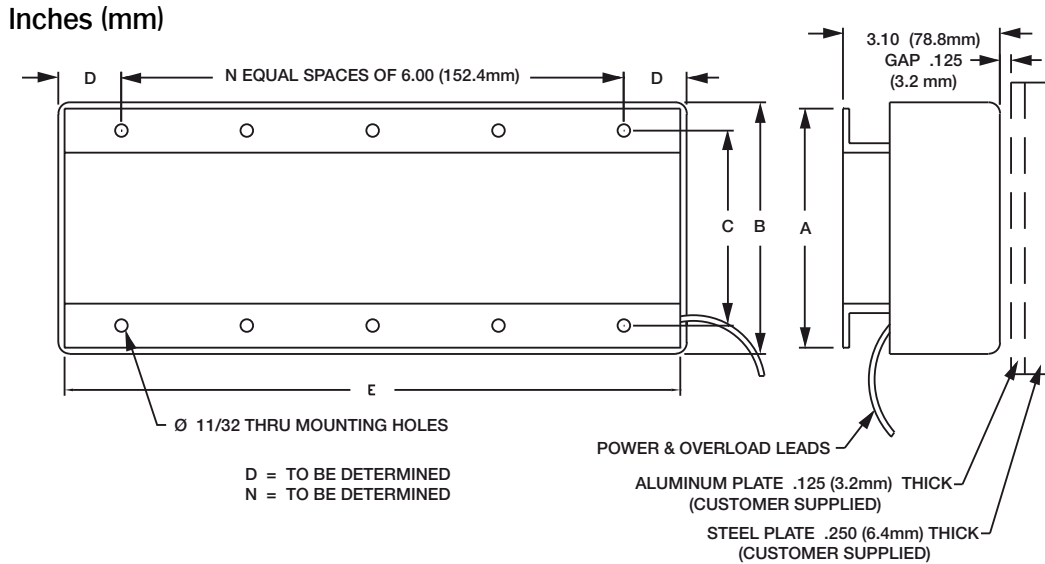

Figure 5

Plots % thrust (force) vs. % velocity.

AC Linear Induction Motor Dimensions



Coil Assembly Dimensions

Catalog Number	Catalog Number	A		B		C	
		mm	in	mm	in	mm	in
LMAC1607CXXXX	LMAC3207CXXXX	165	6.5	178	7	127	5
LMAC1608CXXXX	LMAC3208CXXXX	191	7.5	203	8	152	6
LMAC1609CXXXX	LMAC3209CXXXX	216	8.5	229	9	178	7
LMAC1610CXXXX	LMAC3210CXXXX	241	9.5	254	10	203	8
LMAC1611CXXXX	LMAC3211CXXXX	267	10.5	279	11	229	9
LMAC1612CXXXX	LMAC3212CXXXX	292	11.5	305	12	254	10
LMAC1613CXXXX	LMAC3213CXXXX	318	12.5	330	13	279	11
LMAC1614CXXXX	LMAC3214CXXXX	343	13.5	356	14	305	12
LMAC1615CXXXX	LMAC3215CXXXX	368	14.5	381	15	330	13
LMAC1616CXXXX	LMAC3216CXXXX	394	15.5	406	16	356	14

Catalog Number	D		E		N
	mm	in	mm	in	-
LMAC16XXCXXXX	54	2.13	400	15.8	2
LMAC32XXCXXXX	25.4	1.0	800	31.5	5

NOTE: All specifications are for reference only.
XXXX = refer to ordering information p22.

Non-Commutated DC Linear Servo Motors

- › For closed or open loop systems
- › Moving coil or moving magnet versions
- › Constant and reversible forces to 667 N [150 Lbs]
- › Acceleration to 98 m/s² [10 g's]
- › High accuracy 2.5µm/300m [±0.0001 in/ft] (encoder dependent)
- › High repeatability in 1µm [±0.00004] (encoder dependent)
- › No commutation required
- › Highly compact design
- › For closed or open loop systems
- › Linear recirculating, jewel sapphire, or bronze bearings



MOVING MAGNET



MOVING COIL

Non-commutated DC linear motors operate at very high speeds without cogging or force ripple and with infinite resolution. For closed loop operation, the motor is coupled with an appropriate feedback device, motor control and motion controller.

The Moving Coil model consists of a cylindrical coil that moves within an annular air gap of the magnet assembly, made of rare earth magnets. When DC voltage is applied, the coil moves with constant force and when polarity is reversed, the direction of travel is reversed. Magnetic-attractive forces and hysteresis loss are eliminated.

The Moving Magnet model is like a piston moving within a cylinder. The piston consists of permanent magnets with steel pole pieces and a shaft that passes axially through its center. Endcaps with bearings on both ends of the cylinder support the shaft. The cylinder contains a bobbin to support the coil and an outside steel tube for containing the magnetic flux. DC voltage applied to the coil causes the assembly to move and when the polarity is reversed the direction of travel is reversed.

DC Brushed Linear Servo Motors

- › High forces to 1070 N [171 Lbs]
- › High acceleration to 49 m/s² [5g's]
- › High speeds to 3.8 m/s [75 in/sec]
- › High accuracy 8.3 µm/m [±0.0001 in/ft] (encoder dependent)
- › High repeatability in 1 µm [0.00004] (encoder dependent)
- › Stroke lengths to. 3.2 m [11 ft]
- › Multiple moving magnet assemblies with overlapping trajectories
- › Self-commutation enables the use of low-cost brush-type amplifiers.



The permanent magnet brush commutated DC linear motor consists of a stationary primary and a moving secondary. The stationary primary is a steel laminated core, with multiple coils inserted into insulated slots. The ends of each coil are connected to a commutator bar that is mounted on an aluminum angle.

The moving secondary features multiple permanent magnets and brushes for commutation. A cable supplies power to the moving secondary. The magnetic-attractive force between the primary and

secondary can be used as a magnetic preload for the bearing system.

The brush linear motor is available in different cross sections to meet different force requirements. Mounting holes are located on both the primary and secondary.

Polynoid Linear Motors

- › Forces to 445 N [100 Lbs]
- › Acceleration to 9.8 m/s² [1g]
- › Speeds to 2.3 m/s [90 in/sec]
- › Optional built-in electronic brake (holding coil) for end holding
- › Integral rulon bearings
- › Low cost, powered by AC line voltage or adjustable speed with an inverter
- › Provides long stroke with uniform force
- › Stroke limited by end stops on moving rod
- › Limited duty cycle applications
- › Virtually maintenance free
- › Not for positioning applications

The AC Polynoid provides a constant force for the entire length of its stroke. Its direction of travel is reversible by switching leads. Switching requires the swapping of any two of three motor leads in three-phase units while single-phase reversing is done by the swapping of one line lead to the opposite side of the capacitor lead. Electrical force reversal can be used for dynamic braking. Equal force is provided in either direction of movement.

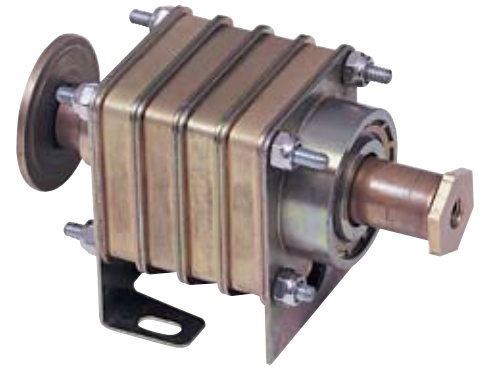

A polynoid is comprised of two basic parts, a rod and a stator. The rod is copper clad steel, the end of which can feature a tapped mounting hole. An optional holding coil is available for end holding at one or both ends. The rod can be of infinite length when provided with proper support. The stator is a series of coils wound on bobbins. Coils are interconnected. The stator is housed in a smooth cold rolled steel assembly. It is also available with fins for improved heat dissipation.

HyCore10 Hybrid Core Linear Motor

- › Velocities to 1.5 m/s (60 ips)
- › Accelerations to 3g
- › Peak forces to 800 N (180 lbs)
- › Continuous force to 465 N (105 lbs)
- › Unlimited travels > 100m (4000 inch)
- › Highly efficient - provides higher forces with an overall smaller electrical load
- › Stationary "platen" without magnets
- no attraction of loose metal particles
- › Compact package - allows designers to work with smaller footprints

Baldor has redefined linear motors with a technological breakthrough. Baldor's new HyCore™ motor combines the best features and performance of traditional high speed, high force, closed loop brushless linear servo motors, with the



cost advantages of open loop linear stepper motor technology. HyCore™ includes benefits which linear motors bring to an application: zero backlash; high efficiency; unlimited travel; fast velocities and high accelerations.

Custom Linear Products

Baldor manufactures a wide variety of custom linear motors and stages. Whether the requirement is for single axis, dual axis or X-Y-Z positioning, Baldor has the linear product for the application. Using linear technology, a linear stage gantry will speed up and simplify the building of equipment needing high throughput and precise positioning.

- › Forces to 750N [169 lbs] at 10% DC
- › Acceleration to 19.6 m/s² [2 g's] on x-axis
and 44.1 m/s² [4.5 g's] on y & z-axis
- › Accuracy of 12 μm/300 mm [±0.0005 in/ft]
- › Speeds up to 3 m/s [90 in/sec] based on 1 μm encoder
- › Strokes up to 2000 x 1500 mm [78 x 60 in]

Using linear motor technology, a linear stage gantry is more compact than conventional gantry systems and is ideal for applications where space is at a premium. Each axis features linear brushless cog-free motors.

Linear Stages

A linear motor positioning stage is defined as a single or multiple-axis mechanical system, that positions a payload. It includes a linear motor, bearings, encoder, limit switches, cable carrier and bellows.

A linear motor provides direct linear motion without mechanical transmission devices. Linear motor positioning stages can move the payload vertically or horizontally at varying rates of speed and acceleration. Linear motor positioning stages have a lower profile and can fit into smaller spaces than conventional positioning stages. Because linear motor positioning stages have fewer components, they are very reliable.



Advantages of Linear Stages

- › High speeds – 10 m/s [400 in/s] with encoder resolution › 1 micron
- › High accelerations – up to 98 m/s² [10 g's]
- › Accuracy – typically ±5 μm/300 mm [±0.0002 in/ft]
- › Small, compact footprint – fits into smaller spaces
- › Reliability – non-contact operation reduces component wear and maintenance
- › High linear motor stiffness – provides excellent dynamic and settling time performance
- › No backlash from gears or slippage from belts – provides smooth operation

Types of Linear Stages

Baldor offers many types of linear motor positioning stages to meet a variety of application requirements.

- › Single Bearing Positioning Stage
- › Extruded Positioning Stage
- › Enclosed Positioning Stage
- › Cross Roller Positioning Stage

Feature	Description
Complete enclosure	Linear motor, bearings, encoder, limit switches, cable carrier and bellows
Bearings	Recirculating ball, cross roller, air bearings
Reliability	Non-contact operation without component wear or maintenance
Stiffness	Excellent dynamic response and rapid settling time
Orientation	Horizontal or vertical (with proper safety)
Resolution	Feedback encoders available from 10 mm to 0.1 μm

› Linear Stage Product Characteristics Overview



Page 31

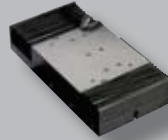

Page 31



Page 32

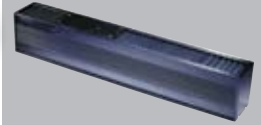

Page 32

		Single Bearing	Cross Roller Bearing	Enclosed	Extruded
Motor Series		LSS	LSC	LSE	LSX
Continuous Force	N	13 - 400	90 - 270	85 - 1020	44 - 356
	Lbs	3 - 99	20 - 60	20 - 240	10 - 80
Peak Force	N	39 - 750	270 - 667	270 - 3200	134 - 1065
	Lbs	9 - 169	60 - 150	60 - 720	30 - 240
Acceleration (1)	m/s²	44.1	49	44.1	44.1
	g's	4.5	5	4.5	4.5
Speed (2)	m/s	5	0.75	5	2
	in/sec	200	30	200	78
Maximum Stroke	m	2.4	0.3	3.3	3
	in	96	12	130	120
Accuracy (3)	µm/300mm	5	5	5	5
	in/ft	0.0002	0.0002	0.0002	0.0002
Repeatability (3)	µm	1	1	1	1
	in	0.00004	0.00004	0.00004	0.00004
Positioning Type	-	closed loop	closed loop	closed loop	closed loop
Control Type	-	Brushless Control	Brushless Control	Brushless Control	Brushless Control
Load Support	-	Linear Recirculating Bearing	Cross-Roller Bearing	Linear Recirculating Bearing	Linear Recirculating Bearing

NOTES:

All specifications are for reference only.

(1) Limited by bearing type.

(2) Dependent upon motor

(3) Accuracy and repeatability are referenced against a laser interferometer. Tighter tolerances are available.

Single Bearing Positioning Stage (LSS)

- › Single-axis stage with cog-free linear motor, linear bearing, linear encoder, limit switches, and cable carrier
- › High forces up to 750 N [169 Lbs.]
- › High accelerations to 44 m/s² [4.5 g]
- › Speeds to 2.5 m/s [100 in/s] with encoder resolution \leq 1 micron
- › High speeds to 5 m/s [200 in/s] with encoder resolutions $>$ 1 micron
- › Payloads to 23 Kg [50 Lbs.]
- › Stroke length to 2.44 m [96 in]
- › Linear encoder feedback of 5 micron resolution standard
- › Turnkey positioning system
- › High stiffness linear recirculating bearings
- › High reliability
- › Low maintenance
- › Use with Trapezoidal or sinusoidal 3-phase brushless control and single-axis motion controller to close the position loop



The small cross section single bearing positioning stage features a moving coil 3-phase cog-free brushless motor with single rail, two integral linear bearings and encoder. The stage features lightweight moving parts for higher acceleration of light loads. An open linear scale is available to meet customer requirements. Resolutions available are 1 and 5 micron.

The cog-free brushless linear motor provides smooth, high reliability, non-contact operation without backlash. Excellent dynamic and

settling time performance is a result of the superior stiffness of brushless motors.

Single bearing positioning stages can be stacked on top of each other to provide a multiple axis positioning system. Typically, a wider cross section is used as the base axis for stability and stages with smaller cross sections stacked on top.

Cross Roller Positioning Stage (LSC)

- › Cross roller bearings for heavy payloads to 90 Kg [200 Lbs]
- › High forces to 667 N [150 Lbs.]
- › Acceleration to 49m/s² [5 g]
- › Speeds to 0.75 m/s [30 in/sec]
- › Strokes to 0.3 m [12 in]
- › Linear encoder feedback with 1 micron resolution standard
- › Housing made of steel or aluminum
- › Single-axis stage with linear motor, linear bearings, linear encoder, limit switches, cable carrier, and bellows
- › Available with brushless iron core linear motors, cog-free brushless linear motors, brush linear motors, and AC induction linear motors
- › Hard stops
- › Low profile, smaller cross section
- › Brushless motor for high reliability and low maintenance
- › Use with Trapezoidal or sinusoidal 3 phase brushless control and single-axis motion controller to close the position loop.



The low-profile positioning stage features a moving coil 3 phase brushless motor with integral linear bearing and encoder. The stage features heavy duty construction with lightweight slide and moving parts for higher acceleration.

Abbe error is minimized by centering the linear motor and encoder between two parallel rails. Two cross roller bearing assemblies support the payload, moving coil and encoder head. An enclosed or open linear scale is available to meet customer requirements.

The brushless linear motor provides high reliability, non-contact operation without backlash or component wear.

Optimal dynamic and settling time performance is a result of the superior stiffness of brushless motors.

Cross roller bearing positioning stages can be stacked on top of each other as shown in picture above to provide a multiple axis positioning system. Typically, a wider cross section is used as the base axis for stability and stages with smaller cross sections stacked on top.

Enclosed Positioning Stage (LSE)

- › Single-axis stage with linear motor, linear bearings, linear encoder, limit switches, cable carrier, spring loaded hard stops and bellows
- › Available with brushless iron core linear motors, cog-free brushless linear motors, brush linear motors, and AC induction linear motors
- › High forces to 3,200 N [720 Lbs.] with Linear Brushless Iron Core motors
- › High acceleration to 44 m/s² [4.5 g]
- › High speeds to 5 m/s [200 in/sec] with encoder resolution > 1 micron
- › Payloads to 227 Kg [500 Lbs.]
- › Strokes to 2.44 m [96 in]
- › Available in three different widths
- › High stiffness linear recirculating bearings
- › Highest load capacity of all the positioning stages with multiple bearings
- › Multiple moving tables with independent operation For vertical applications, an optional constant force spring counteracts gravity
- › Failsafe braking with optional spring loaded pneumatic cylinder for vertical applications
- › Base and table made of aluminum as standard - steel optional
- › Use with Trapezoidal or sinusoidal 3 phase brushless control and single-axis motion controller to close the position loop



The enclosed stage features a moving coil 3 phase brushless motor with integral recirculating linear bearing and encoder. It features heavy duty construction with lightweight moving parts for higher acceleration.

Abbe error is minimized by centering the linear motor and encoder between two parallel rails. Multiple bearings support the payload, moving coil and encoder head. An enclosed or open linear scale is available to meet customer requirements. Standard 5 micron resolution is provided.

The brushless linear motor provides high reliability, non-contact operation with backlash or component wear. Dynamic performance with low settling times is provided by the stiffness of the linear brushless motor.

Enclosed stages can be stacked on top of each other to provide a multiple axis positioning system. Typically, the wider unit is used as the base axis for stability and stages with smaller cross sections stacked on top.

Extruded Positioning Stage (LSX)

- › Linear brushless iron core motor with peak force ratings to 1065 N [240 Lbs]
- › Speeds to 2 m/s [78 in/s] with standard 5 micron encoder resolution
- › Strokes to 3 m [120 in] standard, longer travels available as custom
- › 5 micron linear magnetic encoder scale standard with other resolutions available as custom
- › Single-axis stage – Modular aluminum construction with integral brushless linear motor, linear encoder, limit switches, cable carrier, linear bearings and bellows
- › Turnkey operation
- › Internal linear motor cable carrier
- › High stiffness linear recirculating ball bearings with low friction seals
- › Use with Trapezoidal or sinusoidal 3-phase brushless control and single-axis motion controller to close the position loop



The extruded positioning stage is a cost-effective solution for those applications requiring less stringent positioning requirements. It features lightweight moving parts for high acceleration of light loads. The brushless linear motor provides smooth, highly reliable non-contact operation with no backlash or component wear.

Dynamic performance with low settling times is provided by the brushless motor stiffness. Its essentially square shape and integral cable carrier allows mounting multiple stages close together. These stages can also be stacked to provide multi-axis positioning.

Engineering Information

- › Calculating Linear Motor Requirements
- › Linear Motor Requirement Sheet
- › Linear Stepper Motor Description
- › Linear Stage Components
- › Frequently Asked Questions
- › Conversion Tables



Calculating Motor Requirements

In order to determine the correct motor for particular application it is necessary to be familiar with the following relations.

Equations Of Motion

Basic kinematic equations:

$$v_t = v_o + at$$

$$x_t = v_o t + at^2/2$$

$$v_t^2 = v_o^2 + 2ax$$

- a = acceleration (m/s² [g's])
- x = stroke (m [inch])
- t = time (seconds)
- v_o = initial velocity (m/sec² [in/sec²])
- v_t = velocity at time t (m/sec² [in/sec²])
- g = gravitational acceleration (= 9.81 m/sec² [386 in/sec²])

A trapezoidal velocity profile is common with linear motors and the basic kinematic equations can be manipulated to yield results based on what is known.

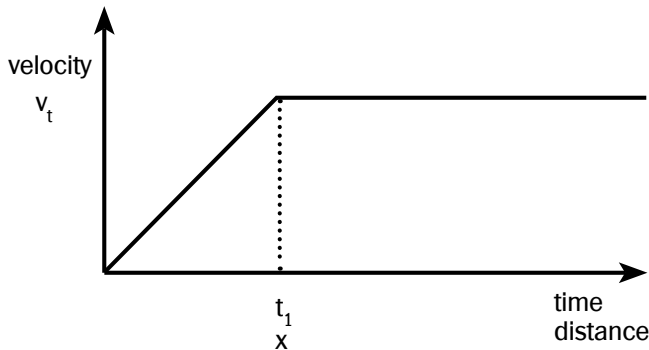

Metric

English

When time and stroke are known:

$$a = \frac{2x}{t_1^2}$$

$$a = \frac{2x}{386 t_1^2}$$

When time and velocity are known:

$$a = \frac{v_t}{t_1}$$

$$a = \frac{v_t}{386 t_1}$$

When velocity and stroke are known:

$$a = \frac{v_t^2}{(2x)}$$

$$a = \frac{v_t^2}{386 (2x)}$$

Example: Calculate the acceleration required to get to 0.508 m/sec [200 in/sec] in 0.050 sec.

Metric

$$a = \frac{0.508}{0.050}$$

$$a = 10.16 \text{ m/s}^2$$

English

$$a = \frac{200}{386 \times 0.050}$$

$$a = 1.04 \text{ g's}$$

Another common velocity profile associated with linear motors is the triangular velocity profile. As before, the basic kinematic equations can be manipulated to solve for this case. This is usually the case investigated when applications need to move a full stroke in a given time.

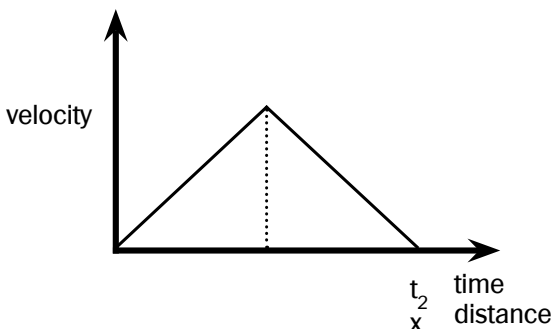

When time and stroke are known

Metric

$$a = \frac{4x}{t_2^2}$$

English

$$a = \frac{4x}{386 t_2^2}$$

Calculating Motor Requirements

Example: Calculate the acceleration required to get to move 0.0254 m [1 in] in 0.050 sec.

Metric

$$a = \frac{4 \times 0.0254}{(0.050)^2}$$

$$a = 40.64 \text{ m/s}^2$$

English

$$a = \frac{4 \times 1}{386 \times (0.050)^2}$$

$$a = 4.14 \text{ g's}$$

Newton's Second Law

Newton's Second Law provides a simple method of converting between forces, payloads, and accelerations.

	Metric	English
	$F = ma$	$F = ma$
where		
F = Force	N	Lbf
m = payload	Kg	Lbm
a = acceleration	m/s ²	g's
g = gravitational constant	9.81 m/s ²	386 in/sec ²

Example: Calculate the force required to accelerate a 1.45 kg [3.2 Lbm] payload horizontally at 12.75 m/s² [1.3 g's]

Metric

$$F = 1.45 \times 12.75$$

$$F = 18.5 \text{ N}$$

English

$$F = 3.2 \times 1.3$$

$$F = 4.16 \text{ Lbs}$$

Duty Cycle for Open Loop Systems

The duty cycle of a motor is defined as the time the motor receives power during a cycle divided by the total time of the cycle. When a linear motor receives power for more than thirty (30) seconds, it is operating at a duty cycle of 100%.

$$\text{Duty Cycle} = \frac{\text{time on}}{\text{time on} + \text{time off}} \times 100\%$$

Example: During one cycle of operation a motor is on for 1 sec and off for 3 sec. What is the duty cycle of the motor for these conditions?

$$\text{Duty Cycle} = \frac{1}{1 + 3} \times 100\% = 25\%$$

Because duty cycles less than 100% allow time for the motor to cool, a lower duty cycle allows all linear motors, except steppers, to be run up to three times their continuous current rating for a short period of time. Since force is proportional to current, motors operating at lower duty cycles can produce higher forces than when run continuously.

Calculating Motor Requirements

Effective Continuous Force

The relation between the rated continuous force a motor can deliver and the effective continuous force it is capable of providing at a lower duty cycle is:

$$F_{DC} = F_c \sqrt{\frac{100}{D.C.}}$$

Where	Metric	English
F_c = continuous force	N	Lbf
$F_{D.C.}$ = force at specified duty cycle	kg	Lbf
D.C. = duty cycle	%	%

Example: A motor has a continuous force capability of 108 lbs (480N) calculate the force which this motor can deliver at a 30% duty cycle.

$$F_{DC} = 480 \sqrt{\frac{100}{30}} = 877 \text{ N}$$

$$F_{DC} = 108 \sqrt{\frac{100}{30}} = 197 \text{ lbs}$$

Linear Motor Selection Process

Following is an example in the selection process for an application that requires a cog-free brushless linear motor. The second section provides the calculations that are necessary to make the motor selection. That last section demonstrates the effect of reducing duty cycles and application on motor selection.

Example Customer Requirements

Stroke	1.52m (60 in in)
Payload	18.1 kg (40 Lbm)
Resolution	3 micron customer-supplied encoder
Load Support	Customer-supplied bearings
Motion Profile	Low force ripple required. Payload must move full stroke in 0.90 sec. The duty cycle is 30%.

Calculating Motor Requirements

Acceleration is determined by:

Metric

$$a = \frac{4x}{t^2} = \frac{4 \times 1.52}{(0.90)^2}$$

$$a = 7.5 \text{ m/s}^2$$

English

$$a = \frac{4x}{386 t^2} = \frac{4 \times 60}{386 \times (0.90)^2}$$

$$a = 0.77 \text{ g's}$$

Force is determined by:

$$F = ma = 18.1 \times 7.5$$

$$F = 136 \text{ N}$$

$$F = ma = 40 \times 0.77$$

$$F = 30.8 \text{ lbf}$$

Force required by an application with a 30% duty cycle is determined by:

$$F_{DC} = F_c \sqrt{\frac{100}{DC}} \quad \text{Re-arranging:} \quad F_c = \frac{F_{DC}}{\sqrt{\frac{100}{DC}}}$$

$$F_c = \frac{136}{\sqrt{\frac{100}{30}}} = 75 \text{ N}$$

$$F_c = \frac{30.8}{\sqrt{\frac{100}{30}}} = 16.8 \text{ lbf}$$

As the customer's requirement is for low ripple, the optimum product selection is a cog free motor.
The motor which delivers this force is the LMIC06C (87N; 19.5 lbs)

Linear Motor Sizing

Baldor's LIMOS (Linear Motor Sizing) program is a Windows-based application to help you size your linear motor.

LIMOS includes a simple wizard interface asking a series of questions about your application. Once the motor type is selected, a move profile can be created. LIMOS will then calculate the motor size for you.

Download from www.baldormotion.com/support or contact Baldor to receive this program.



Linear Motor Requirement Sheet

Company _____	Date _____
Contact _____	Email _____
Title _____	Phone _____
Address _____	Fax _____
Address _____	Industry _____
City _____	District Office _____
State, Zip _____	Salesperson _____

Describe the application and what you are trying to accomplish:

Motor Type Preferred

- Don't Know
 Servo - Closed loop
- Brushless Cog-free
- Brushless Iron-core
- Brush type
 Stepper - Open Loop
- Single Axis
- Dual Axis w/Air Bearing
- AC Induction
- Stage**

Voltage Available

- 115 VAC Single Phase
- 230 VAC Single Phase
- 230 VAC Three Phase
- 460 VAC Three Phase
- DC: _____

Environment

- _____ Degrees F
- _____ Degrees C
- Dusty
- Gritty
- _____
- _____

Mounting

- Horizontal - Table
- Horizontal - Wall
- Vertical with
 _____ % Counterbalance
- Angled at _____ Degrees

Position Resolution

- None Required
- 10 Micron = 0.0004 inch
- 5 Micron = 0.002 inch
- 1 Micron = 0.00004 inch
- Other _____
- Stepper Repeatability of _____

Quote Additional

- Drive (Amplifier)
- Position Controller
- Linear Encoder
 w/resolution from above
- Motor Power & Hall
 Cable Length _____

Cooling Available

- Convection - standard
- Forced Air *
- Water *

* Not available on all motor types

Linear Stepper Motors

The open loop linear stepper motor provides the most economical linear motor positioning solution. There are two types of linear stepper motors, a single-axis linear stepper motor that can be stacked to provide multiple axes and the compact dual-axis linear stepper motor that provides travel along two axes in a single plane. Linear stepper motors incorporate the motor, positioning system and bearings into two components, a moving forcer and a stationary platen.

Single Axis Linear Stepper

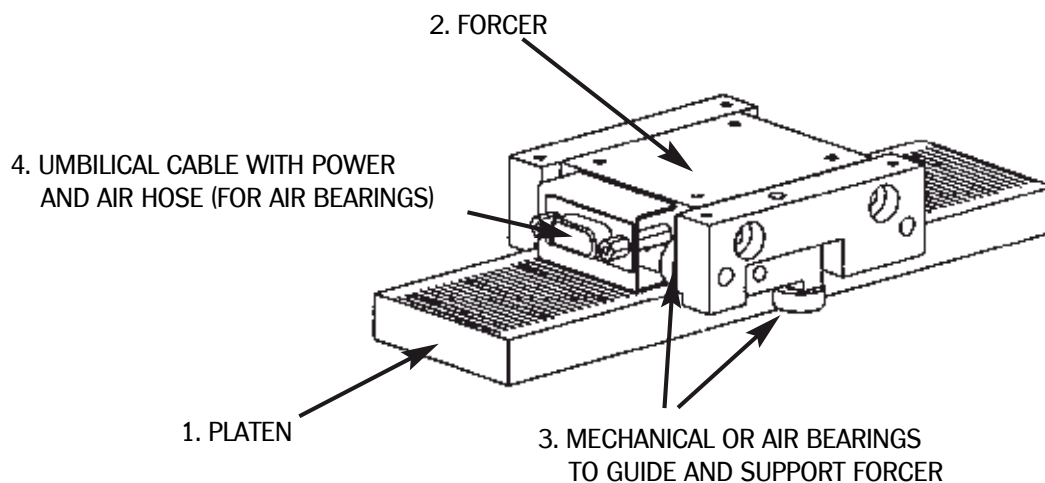

1. Platen

The platen on the single-axis stepper motor has a nickel plated photo-chemically etched teeth on a steel bar or tube that is filled with epoxy (RoHS compliant). A tube type platen is required for unsupported applications. The platen of a dual-axis linear stepper motor is a waffle or checkerboard arrangement of teeth etched onto a steel plate in a grid pattern. The magnetic-attractive force between the forcer and platen provides a preload for the bearing system. The integral bearing system maintains the required air gap.

2. Forcer

The single-axis linear stepper motor's moving primary (forcer) is made of multiple laminated steel cores precisely slotted with teeth and permanent magnets. The coils are inserted into the laminated core assemblies, which are encapsulated in an aluminum housing. The dual-axis linear stepper motor's moving primary (forcer) is made of four single-axis assemblies. Two of the forcer assemblies are mounted in series to provide thrust along the X-axis and the other two are mounted orthogonal to the first two assemblies to provide thrust along the Y-axis. Lamination assemblies are encapsulated with epoxy in a hard-anodized aluminum housing. The motor face is lapped to provide a flat air-bearing surface. Multiple forcers that move independently are available on single-axis and dual-axis linear stepper motors.

Dual Axis Linear Stepper

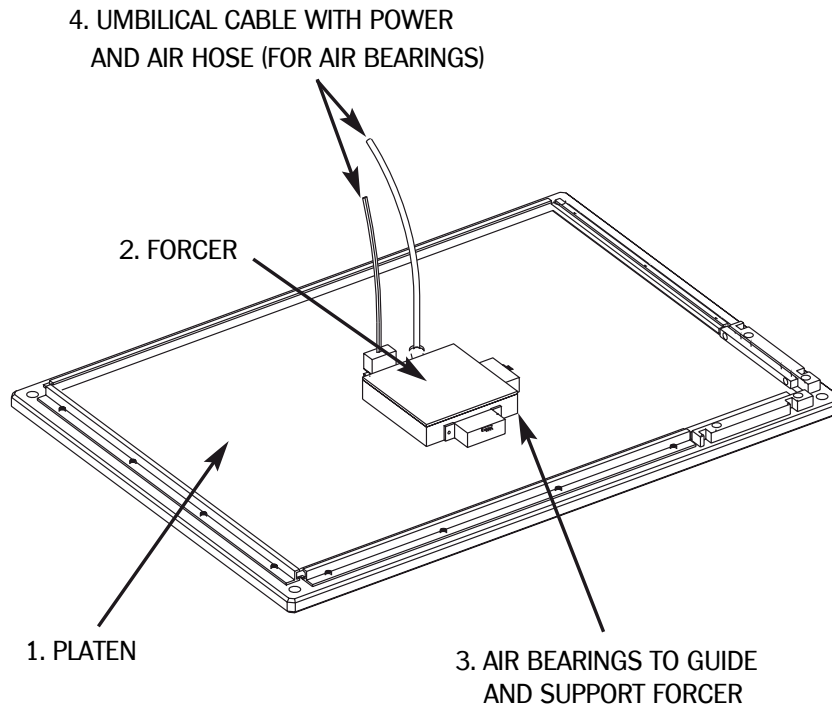

3. Mechanical Or Air Bearings To Guide And Support Forcer

The single-axis stepper is available with mechanical or air bearings. The dual-axis stepper is available only with air bearings.

4. Umbilical Cable With Power And Air Hose (For Air Bearings)

Customer must supply power and dry filtered air for air bearings.

Linear Stepper Motor Operation

Linear stepper motors divide linear distances into discrete incremental moves called steps. The size of each step is determined by the spacing of the steel teeth in the platen and how the coils are energized. Baldor 2-phase motors travel 0.254mm (0.010 inches) in a single full step yielding 100 steps per inch (25.4 mm). Baldor 4-phase motors travel 0.127mm (0.005 inches) in a step. When the coils are energized in a predetermined pattern the forcer will walk its way down the platen. Reversing the pattern will reverse the direction of travel. The frequency at which the microsteps are generated determine the velocity of the forcer. Linear stepper motors produce their maximum force at zero speed. As speed increases the ability to switch winding current decreases due to motor inductance and back EMF. This results in lower forces at higher speeds.

Linear Stage Components

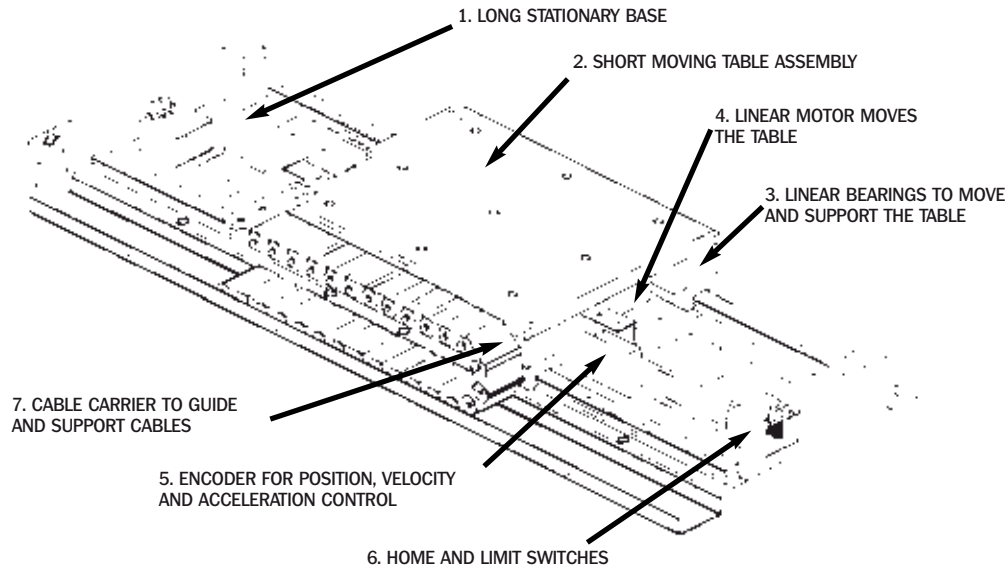

1. Stationery Base

The linear motor driven positioning stage is built on a stationary base that provides a stable, precise and flat platform. Typically, the base is made from an aluminum, steel, ceramic or granite plate. All stationary parts of the positioning components are attached to the base. The base of the stage is attached to the host system with mounting screws.

2. Moving Table

The moving parts of the various positioning components are attached to the moving table. The moving table is made of a lightweight material, such as aluminum, that allows maximum acceleration. Mounting holes on the moving table secure the payload to the table.

3. Linear Bearings

Precise lateral and vertical guidance of the moving table is provided by mounting one or more linear bearing rails attached to the base plate with one or more linear recirculating ball bearings or air bearings on each rail.

4. Linear Motor

The moving table is driven with an AC or DC linear motor. The type of linear motor, [AC induction, DC brush, iron core brushless or cog-free (ironless core) brushless linear motor] is determined by the application requirements. All of the brushless motors provide non-contact operation with non-wearing parts and provide higher forces in a smaller package.

The AC induction linear motor is typically used for heavy loads in open loop systems or a vector control can be utilized for closed position loop operation.

The brush DC linear motor provides an economical linear motor solution. Key features of the brush linear motor include its low cost per pound of thrust compared to brushless linear motors, self commutation that enables the use of low-cost brush type amplifiers and lightweight moving secondary that enables high acceleration.

Linear Stage Components

Brushless iron core linear motors provide the most economical brushless iron core linear motor solution. Key features of the brushless linear motor include the lowest cost per pound of thrust, a preload for the bearing system provided by the magnetic-attractive force between coil and the skewed magnet track. Various coil features and skewed magnets reduce cogging.

High force brushless linear motors provide the highest force linear motor solution. Key features of high force brushless linear motors include a preload for the bearing system provided by the magnetic attractive force between primary and secondary, skewed magnets and various coil features that reduce cogging.

Cog-free (ironless core) brushless linear motors provide the greatest precision for profiling and contouring applications. Key features include cogfree operation with low velocity ripple and no magnetic-attractive force between the coil and the magnet track. It is the best brushless solution for light loads and high acceleration with low mass.

The AC Linear Induction Motor (LIM) is a low cost solution for moving heavy loads, such as material handling and people movers. Key features include availability in any width or length and operation from AC line voltage. Typically, the LIM is used for open loop position applications, however it can be used with a vector control for position control or an inverter for velocity control.

5. Position Feedback

Closed loop servo systems require a positioning feedback device, usually a non-contact device, such as a glass scale or magnetic linear encoder. The encoder allows precise control of the stage's position, velocity and acceleration. Attached to the moving table, the encoder's head is guided by the linear bearings on the stage.

6. Home and Limit Switches

Non-contact limit switches are built into the stage or encoder head to provide initial homing and over travel protection for the stage.

7. Cable Carriers

A cable carrier couples the moving table to the stationary connector box at the end of the stage and routes the high flex cables from the motor and encoder to the base.

8. Operation

Motion is achieved by connecting the motor to an appropriate amplifier and, in a closed loop system, the position loop is closed with a motion controller.

Frequently Asked Questions About Linear Motors

Q. What performance improvements can be expected with linear motors?

A. In most applications, repeatability and accuracy will be increased. Move times and settling time will be decreased. Baldor's sizing program will assist you in determining a linear motor for your application by calculating move times, speeds, and acceleration.

Q. How accurate are linear motors?

A. By eliminating the conversion of rotary to linear motion, a major source of positioning error is removed. This results in high performance and accuracy is ultimately determined by the linear encoder feedback accuracy. Repeatability will be within a few encoder counts.

Q. How fast can linear motors go?

A. There are several factors that limit speed of the linear motor. The control must provide sufficient bus voltage to support the speed requirements. The encoder itself must be able to respond to that speed and its output frequency must be within the controller's capability: for example, with a 0.5 micron encoder and a speed of 200 ips, the controller must handle 10MHz. Finally the speed rating of the stage's bearing system must not be exceeded: for example, in a recirculating ball bearing, the balls start to skid (rather than roll) at about 200 ips.

Q. What happens if the system loses power or velocity feedback?

A. If a power loss occurs, the system loses all stiffness. So, if the payload is moving, it will continue to move until it hits a stop or until friction brings it to a stop. If the system is already stopped, it will not be affected. If the feedback loop is lost, it may lead to a runaway situation. This condition can be avoided with the use of soft and hard stops as well as braking systems.

Q. Do magnets ever lose their magnetism over time?

A. Baldor's linear motors use rare earth magnets, which maintain their strength over time. However, when operating at high temperatures (>150°C), rare earth magnets can lose strength.

Q. What is cogging?

A. Cogging is a tendency of some linear motors to move in discrete distances rather than infinitely variable distances. The effect is a result of varying magnetic forces along the length of motor travel.

Q. Will linear motors produce enough force for my application?

A. Baldor's smallest linear motor will produce 2 N [0.5 lbs] of continuous force. The largest can provide 16100N [3700 lbs] of peak force at 10% duty cycle.

Q. Are linear motors difficult to integrate into a machine?

A. Not difficult, different. The drive train is simpler to install, as the linear motor replaces the ball screw, nut, end bearings, motor mount, couplings and rotary motor. Alignment with a Baldor motor is not critical (even for high performance packages) and consists of mainly ensuring clearances for the moving coil is maintained over the travel. Baldor will assist with selection of suitable components.

Frequently Asked Questions About Linear Motors

Q. What is duty cycle?

A. Duty cycle is defined as (time on) / (time on + time off) per cycle. A lower duty cycle allows the motor to be run with as much as three times its continuous current rating for a short time period to produce higher forces than if the motor runs continuously.

Q. Do standard rotary motor electronics work with linear motors?

A. Baldor's linear motors are designed to operate with most off-the-shelf motor controls and drives. Basically, linear motors use the same electric circuit as rotary motors. This applies to stepper, brush, brushless, and AC linear motors alike.

Q. Can a linear motor be mounted vertically or upside-down?

A. Yes, a linear motor provides the same performance when mounted vertically, upsidedown, or horizontally. However, a vertically mounted linear motor must be counterbalanced.

Q. Can more than one stepper motor forcer be mounted on a stepper motor platen?

A. Yes, multiple forcers that move independently may be mounted on one platen, as long as they do not physically interfere with each other.

Q. Can more than one brushless linear motor moving coil (primary) assembly be used with a single magnet track (secondary)?

A. Yes, more than one coil assembly can be used in conjunction with a single magnet assembly as long as the coil assemblies do not physically interfere with each other.

Q. Does Baldor make specialty motors for waterproof, vacuum or clean room environments?

A. Yes, linear motors can be built for a variety of operating environments. To determine if a linear motor is suitable for a specific application, an applications engineer must review the specifications.

Q. What are the advantages of a linear motor over a lead screw?

A. The advantages of linear motors include higher velocities (>80 in/sec (>2 m/s)), non-wear moving part, free movement when power is off, no backlash because there are no mechanical linkages.

Conversion Tables

(To convert from A to B, multiply by value in table)

Linear Velocity

A \ B	in/sec	feet/sec	mm/sec	cm/sec	meter/sec	inch/min	feet/min	meter/min	km/hour	miles/hour
in/sec	1	0.083	25.4	2.54	25.4 x 10 ⁻²	60	5	1.524	0.091	5.7 x 10 ⁻²
feet/sec	12	1	304.8	304.8	0.3048	720	60	18.29	1.09	0.682
mm/sec	3.937 x 10 ⁻²	3.3 x 10 ⁻³	1	0.1	0.001	2.36	0.197	0.059	3.6 x 10 ⁻³	2.24 x 10 ⁻³
cm/sec	0.3937	3.28 x 10 ⁻²	10	1	0.01	23.62	1.97	0.59	3.6 x 10 ⁻²	2.24 x 10 ⁻²
meter/sec	39.37	3.281	1000	100	1	2362.2	197	60	3.6	2.24
inch/min	0.0167	1.39 x 10 ⁻³	0.42	0.042	4.2 x 10 ⁻⁴	1	8.33 x 10 ⁻²	2.54 x 10 ⁻²	1.52 x 10 ⁻³	9.5 x 10 ⁻⁴
feet/min	0.2	0.0167	5.08	0.508	5.08 x 10 ⁻³	12	1	0.3048	1.8 x 10 ⁻²	1.14 x 10 ⁻²
meter/min	0.656	5.46 x 10 ⁻²	16.667	1.67	1.67 x 10 ⁻²	39.4	3.28	1	5.9 x 10 ⁻²	0.37
km/hour	10.936	0.911	277.8	27.78	0.2778	656	54.67	16.67	1	0.62
miles/hour	17.59	1.47	447	44.7	0.447	1056	88	26.8	1.609	1

Length

A \ B	Inch	Feet	Micro Inch	Micron	Millimeter	Centimeter	Meter
Inch	1	8.33 x 10 ⁻²	1.0 x 10 ⁶	2.54 x 10 ⁴	25.4	2.54	2.54 x 10 ⁻²
Feet	12	1	1.2 x 10 ⁷	3.05 x 10 ⁵	305	30.5	0.305
Micro-Inch	1.0 x 10 ⁻⁶	1.2 x 10 ⁴	1	2.54 x 10 ⁻²	2.54 x 10 ⁻⁵	2.54 x 10 ⁻⁶	2.54 x 10 ⁻⁸
Micron	3.937 x 10 ⁻⁵	3.28 x 10 ⁻⁶	39.37	1	0.001	1.0 x 10 ⁻⁴	1.0 x 10 ⁻⁶
Millimeter	3.937 x 10 ⁻²	3.28 x 10 ⁻³	3.937 x 10 ⁴	1000	1	0.1	0.001
Centimeter	0.3937	3.28 x 10 ⁻²	3.937 x 10 ⁵	1 x 10 ⁴	10	1	0.01
Meter	39.37	3.28	3.937 x 10 ⁴	1 x 10 ⁶	1000	100	1

Power

A \ B	Watts	Kilowatts	ft.lb/sec ²	in-lb/sec	Hp
Watts	1	1 x 10 ⁻³	0.74	8.85	1.33 x 10 ⁻³
Kilowatts	1000	1	738	8850	1.33
ft-lb/sec	1.35	1.36 x 10 ⁻³	1	12	1.81 x 10 ⁻³
in-lb/sec	0.113	1.13 x 10 ⁻⁴	8.3 x 10 ⁻²	1	1.53 x 10 ⁻⁴
Hp	750	0.750	553	6636	1

Force

A \ B	OZ-f	Lb-f	Newtons	gm-f	Kg-f
OZ-f	1	6.25 x 10 ⁻²	0.278	28.35	2.835 x 10 ⁻²
Lb-f	16	1	4.448	453.6	0.4535
Newtons	3.596	0.225	1	101.9	0.1019
gm-f	3.59 x 10 ⁻²	2.205 x 10 ⁻³	9.81 x 10 ⁻³	1	0.001
Kg-f	35.3	2.205	9.81	1000	1

Mass

A \ B	ozm	lbm	gm	kg
ozm	1	6.25 x 10 ⁻²	28.35	2.835 x 10 ⁻²
lbm	16	1	453.6	0.453
gm	3.53 x 10 ⁻²	2.205 x 10 ⁻³	1	0.001
kg	35.274	2.205	1000	1

Temperature

$^{\circ}\text{F} = (1.8 \times ^{\circ}\text{C}) + 32$

$^{\circ}\text{C} = .555 (^{\circ}\text{F} - 32)$

Gravity

(Acceleration Constant)

$g = 386 \text{ in/s}^2 = 32.2 \text{ ft/s}^2 = 9.8 \text{ m/s}^2$

Material Densities

	oz/in ³	lb/in ³	gm/cm ³
Aluminum	1.57	0.098	2.72
Brass	4.96	0.31	8.6
Bronze	4.72	0.295	8.17
Copper	5.15	0.322	8.91
Plastic	0.64	0.04	1.11
Steel	4.48	0.28	7.75

Mechanism Efficiencies

Acme Screw (Bronze Nut)	0.4
Acme Screw (Plastic Nut)	0.5
Ball Screw	0.9
Helical Gear	0.7
Spur Gear	0.6
Timing Belt/Pulley	0.9

Friction Coefficients

(Sliding)	μ
Steel on Steel	0.58
Steel on Steel (Greased)	0.15
Aluminum on Steel	0.45
Copper on Steel	0.36
Brass on Steel	0.40
Plastic on Steel	0.20
Linear Bearings	0.001

Servo Drive Solutions

Whether you are looking for a simple servo drive or a fully programmable drive, Baldor has the answer. Baldor servo drives have been at the heart of automation for over 20 years and have been used in thousands of applications across the world. Our latest drives build on the reputation of quality and ease of use and are ideally matched to Baldor's range of NextMove motion controllers, rotary servo motors and linear servo motors. Commissioning and setup use the same acclaimed Mint® WorkBench Windows tool as the NextMove controllers, reducing the learning curve and improving productivity.



MicroFlex®

Refer to catalog BR1202-D for full information.

Baldor's MicroFlex is a compact brushless servo drive capable of powering either rotary or linear motors, and is available in single phase 110-230VAC 50/60Hz or 3 phase 230VAC operation in current ratings of 3, 6 and 9 amps. Feedback is software programmable, accepting encoder, SSI (Synchronous Serial Interface) or Hall-effect sensors. Resolver feedback is available as an option. The new MicroFlex e100 offers a fully digital solution utilizing ETHERNET Powerlink to reduce wiring between the drive and motion controller (NextMove e100), increasing reliability and improving set-up time.



FlexDrive-II, Flex+Drive®-II and MintDrive®-II

Refer to catalog BR1202-D for full information.

Baldor's Series-II servo drives offer high performance control of both rotary and linear brushless servo motors. This fully featured drive family offer different feedback options (resolver, incremental and absolute multi-turn encoders) and fieldbuses (CANopen, DeviceNet and Profibus-DP). Models are available with single phase 115/230VAC (2.5 to 7.5A) or universal three phase 180-460 VAC (2.5 to 27.5A) inputs. The FlexDrive-II is a servo drive for connection to a motion controller or PLC accepting the industry standard $\pm 10V$ analog interface. The Flex+Drive-II is a versatile indexing drive. In addition to setting position or speeds within a simple Windows front end, Flex+Drive-II is programmable in a single tasking version of Baldor's motion language, Mint®. The MintDrive-II provides the ultimate solution for single axis applications. Support the acclaimed multitasking version of Mint, MintDrive-II is ideally suited for following type applications requiring cam profiles, flying shears or positional offsets.

VS1SD Drives

Refer to catalog BR702 for full information.

Baldor's new series incorporates an easy to use keypad for setup, auto-tuning and operation. The keypad's graphical alphanumeric display provides full parameter names to simplify setup and operation, 14 keys provide tactile feel. Includes auto-tuning. Optional field installable expansion boards extend capability to suit application needs. Models include internal power supply and are available in three phase ratings from 180-264 VAC (3 to 130A) and three phase 340-528 VAC (3 to 124A). Vector, encoderless vector and inverter drives are also available.



Motor Solutions

For over 20 years, Baldor has been manufacturing and supplying high reliability servo motor solutions to worldwide applications. Baldor's servo motors are designed for industrial applications, superior durability and proven reliability. Our range of rotary motors are available as a high performance, low inertia family, or as a higher inertia family for more cost effective applications. Baldor's new stainless steel motors lead the way in solutions for harsh and washdown environments.

With the widest range of linear motors and stages on the market today, Baldor's linear motors lead the way and are ideally suited to applications requiring higher speeds or improved accuracy.



BSM Series Servo Motors

Refer to catalog **BR1202-E** for full information.

BSM motors are hard at work, increasing productivity, improving part quality, providing precision and reducing costs in many applications. These motors are available in two models, the BSM N-Series and the BSM C-Series. The N-Series motors provide low inertia for the highest performance. The C-Series motors have a higher inertia, with a cost effective design. All the motors are available with different feedback options including resolver, incremental and absolute encoders with continuous stall torques from 0.4 Nm (4 lb.-in) through to 134 Nm (1185 lb.-in).

Both motor families are available in a stainless steel configuration, offering the best protection for harsh environment. These motors are ideally suited for pharmaceutical and food applications.

Motion Control Solutions

With today's automation applications demanding increasing speed and flexibility to stay ahead, finding a control solution to meet those demands can be difficult. Baldor has the answer. Utilizing a high performance, state of the art processor core and coupled with the power, flexibility and ease of use of Baldor's Mint programming language, the NextMove range of motion controllers can take on the most demanding of multi-axis applications.

› A Flexible Solution

Baldor's motion controllers have been at the heart of automation machines for nearly two decades. The NextMove motion controller family is synonymous with power, flexibility and versatility. Operating around the world, NextMove has met the demands of a rapidly developing automation world, providing increased productivity, reliability and flexibility.

NextMove controllers are available in a number of configurations including stand-alone with RS232/485, USB and Ethernet interfaces and PCI-bus. Controllers are available for controlling 1 through to 16 axes of closely coordinated motion, all programmed using Baldor's acclaimed Mint programming language



Baldor's Motion Solutions Catalogs

- BR1202-A** Motion Control Solutions
- BR1202-B** Mint® Software and Applications
- BR1202-C** NextMove Multi-Axis Motion Controllers
- BR1202-D** AC Servo Drives
- BR1202-E** AC Servo Motors
- BR1202-F** DC Servo Motors and Drives
- BR1202-G** Linear Motors and Stages
- BR1202-H** Motion Product Accessories
- BR1202-I** Real-Time Ethernet Motion Solutions

World Headquarters (U.S.A.)

Baldor Electric Company

Tel: +1 479 646-4711
Fax: +1 479 648-5792
E-mail: sales.us@baldor.com

Australia

Tel: +61 2 9674 5455
Fax: +61 2 9674 2495
E-mail: sales.au@baldor.com

China

Phone: +86-21-64473060
Fax: +86-21-64078620
E-mail: sales.cn@baldor.com

Germany

Tel: +49 89 905 08-0
Fax: +49 89 905 08-490
E-mail: sales.de@baldor.com

India

Tel: +91 20 25 45 27 17/18
Fax: +91 20 25 45 27 19
E-mail: sales.in@baldor.com

Italy

Tel: +41 91 640 9950
Fax: +41 91 630 2633
E-mail: sales.it@baldor.com

Japan

Tel: +81 45-412-4506
Fax: +81 45-412-4507
E-mail: sales.jp@baldor.com

Korea

Tel: +(82-32) 508 3252
Fax: +(82-32) 508 3253
E-mail: sales.kr@baldor.com

Mexico

Tel: +52 477 761 2030
Fax: +52 477 761 2010
E-mail: sales.mx@baldor.com

Singapore

Tel: +65 744 2572
Fax: +65 747 1708
E-mail: sales.sg@baldor.com

Switzerland

Tel: +41 52 647 4700
Fax: +41 52 659 2394
E-mail: sales.ch@baldor.com

United Kingdom

Tel: +44 1454 850000
Fax: +44 1454 859001
E-mail: sales.uk@baldor.com

For additional office locations visit

www.baldor.com

Local Distributor: