



# SIZES FROM 2 - 10,000 Nm

## BACKLASH FREE, TORSIONALLY STIFF

### METAL BELLOWS COUPLINGS

#### GENERAL INFORMATION ABOUT R+W BELLOWS COUPLINGS:



**SERVICE LIFE**

R+W bellows couplings are fatigue resistant and wear free for an infinite service life, as long as the technical limits are not exceeded.

**FIT CLEARANCE**

Overall shaft / hub clearance of 0.01 - 0.05 mm

**ROTATIONAL SPEED**

Standard up to 10,000 rpm.  
Over 10,000 rpm in finely balanced version; up to grade ISO G=2.5 is available.

**TEMPERATURE RANGE**

-30 to +100° C

**SPECIAL SOLUTIONS**

Various materials, tolerances, dimensions and performance ratings available for custom applications on request.

**ATEX (Optional)**

For use in hazardous zones 1/21 and 2/22, the metal bellows has been authorized under directive 94/9/EG and is available with certification.

## TORSIONALLY STIFF BELLOWS COUPLINGS SIZES FROM 2 - 10,000 Nm

MODEL

FEATURES

**BK2**



**with clamping hub  
from 15 - 10,000 Nm**

- ▶ easy to mount
- ▶ available in multiple lengths
- ▶ low moment of inertia

Page 34

**BKH**



**with fully split clamping hub  
from 15 - 4,000 Nm**

- ▶ radial mounting possible
- ▶ easy to install onto pre-aligned shafts
- ▶ low moment of inertia

Page 35

**BKL**



**economy class with clamping hub  
from 2 - 500 Nm**

- ▶ economy design
- ▶ optional self-opening clamp system
- ▶ low moment of inertia

Page 36

**BKS**



**with clamping hub  
from 15 - 500 Nm**

- ▶ all stainless steel construction
- ▶ temperatures up to 300°C
- ▶ easy to mount

Page 37

MODEL

FEATURES

**BKC**



**economy class with clamping hub  
from 15 - 500 Nm**

Page 38

- ▶ low moment of inertia
- ▶ compact design
- ▶ optional self-opening clamp system

**BKM**



**with clamping hub  
from 20 - 1,000 Nm**

Page 39

- ▶ high torque density
- ▶ ultra compact
- ▶ lowest moment of inertia of all clamping hub designs

**BK3**



**with conical clamping hub  
from 15 - 10,000 Nm**

Page 40

- ▶ high clamping pressure
- ▶ modern design for removal system
- ▶ highly reliable

**BK4**



**for tapered shafts  
from 15 - 150 Nm**

Page 41

- ▶ standard 1:10 taper with feather keyway
- ▶ special designs on request

## TORSIONALLY STIFF BELLOWS COUPLINGS SIZES FROM 2 - 10,000 Nm

### MODEL

### FEATURES

**BK5**



**with clamping hub and blind mate connection from 15 - 1,500 Nm**

- ▶ backlash free with two piece design
- ▶ easy installation and removal
- ▶ available as separate components

Page 42

**BK6**



**with conical clamping ring and blind mate connection from 15 - 1,500 Nm**

- ▶ eliminates need for screw access holes
- ▶ self centering hubs for highly concentric mounting
- ▶ easy installation and removal

Page 43

**BK7**



**with expanding shaft from 15 - 300 Nm**

- ▶ for hollow shaft mounting
- ▶ save space and cost
- ▶ solution for mismatched shaft/bore diameters

Page 44

**BK8**



**with ISO flange mounting from 50 - 2,600 Nm**

- ▶ for flange output gearboxes
- ▶ allows for continuous hollow through axis with some right angle gearbox designs
- ▶ compact layout

Page 45

MODEL

FEATURES

**BK1**



**with simple flange mounting  
from 15 - 10,000 Nm**

- ▶ for adapting the metal bellows to custom drive components
- ▶ custom flange patterns available

Page 46

# BK2

## WITH CLAMPING HUB

15 - 10,000 Nm

### ABOUT



#### FEATURES

- ▶ easy to mount
- ▶ Optional: bolt tensioning system in size 800 and up
- ▶ light weight and low moment of inertia

#### DESIGN

Two clamping hubs concentrically mounted to flexible bellows. Brief overloads of up to 1.5x the rated torque are acceptable.

#### MATERIAL

- ▶ **Bellows:** high grade stainless steel
- ▶ **Hubs:** see table

**NEW**

**Advantage:** reduce screw tightening torques by up to 90% by using multiple smaller screws to create the same tension.

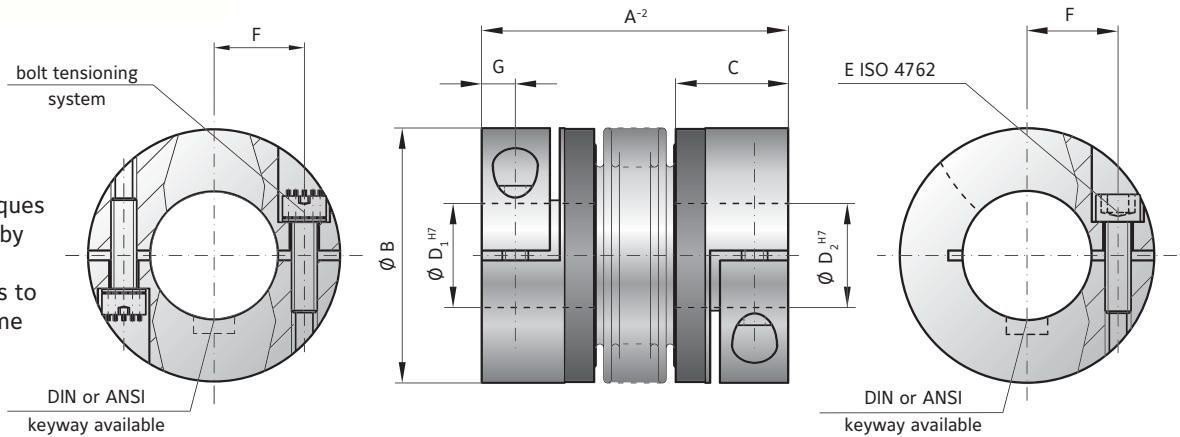

## MODEL BK2

SIZE		15	30	60	80	150	200	300	500	800	1500	4000	6000	10000				
Rated torque (Nm)	$T_{KN}$	15	30	60	80	150	200	300	500	800	1500	4000	6000	10000				
Overall length (mm)	$A^{-2}$	59 66 99	69 77 113 83	93 130 94 106 143	95 107 144 105 117 163	111 125 200 133 146 169	140 179 166 230	225 252 288										
Outside diameter (mm)	B	49	55	66	81	81	90	110	124	134	157	200	253	303				
Fit length (mm)	C	22	27	31	36	36	41	43	51	45	55	85	107	129				
Inside diameter possible from $\emptyset$ to $\emptyset$ H7 (mm)	$D_1/D_2$	8-28	10-30	12-35	14-42	19-42	22-45	24-60	35-60	40-75	50-80	50-90	60-140	70-180				
Fastening screw ISO 4762	E	M5	M6	M8	M10	M10	M12	M12	M16	2x M16*	2x M20*	2x M24*	2x M24*	2x M30*				
Tightening torque of the fastening screw (Nm)		8	15	40	50	70	120	130	200	250	470	1200	1200	2400				
Distance between centerlines (mm)	F	17	19	23	27	27	31	39	41	2x48	2x55	2x65	2x90	2x117				
Distance (mm)	G	6.5	7.5	9.5	11	11	12.5	13	16.5	18	22.5	28	35	42				
Moment of inertia ( $10^{-3}$ kgm <sup>2</sup> )	$J_{res}$	0.06 0.07 0.08	0.12 0.13 0.14	0.32 0.35 0.4	0.8 0.85 0.9	1.9 2 2.1	3.2 3.4 3.6	7.6 7.9 8.3	14.3 14.6 14.8	16.2 17	43 45	165	495	1214				
Hub material		Al optional steel	Al optional steel	Al optional steel	Al optional steel	steel optional AL	steel optional AL	steel optional AL	steel optional AL	steel	steel	steel	steel	steel				
Approximate weight (kg)		0.16	0.26	0.48	0.8	1.85	2.65	4	6.3	5.7	11.5	28.8	49.4	80.9				
Torsional stiffness ( $10^3$ Nm/rad)	$C_T$	20 15 14	39 28 27	76 55 54	129 85 84	175 110 97	191 140 135	450 350 340	510 500 400	780 711	1304 1180	3400	5700	10950				
Axial $\pm$ (mm)	Max. values	1 2 3	1 2 3	1.5 2 3	2 3 4	2 3 4	2 3 4	2.5 3.5 4.5	2.5 3.5 4.5	3.5 4.5	3.5 4.5	3.5 4.5	3	3				
Lateral $\pm$ (mm)		0.15 0.2	1 0.2 0.25	1 0.2 0.25	1 0.2 0.25	1 0.2 0.25	1 0.25 0.3	1 0.25 0.3	1 0.3 0.35	1 0.35 1	0.35 1	0.35 1	0.4	0.4	0.4			
Angular $\pm$ (degree)		1 1.5 2	1 1.5 2	1 1.5 2	1 1.5 2	1 1.5 2	1 1.5 2	1 1.5 2	1 1.5 2	1 1.5 2	1.5 2	1.5 2	1.5	1.5	1.5			
Axial spring stiffness (N/mm)	$C_a$	25 15 84	50 30 118	72 48 165	48 32 144	82 52 130	90 60 280	105 71 605	70 48 85	100 285	320 440	565	1030	985				
Lateral spring stiffness (N/mm)	$C_r$	475 137	140 900	270 224	1200 420	337 920	290 401	1550 435	500 2040	610 750	3750 1050	1200 2500	840 614	2000 1490	3600 1700	6070	19200	21800

\* 180° opposed in each clamping hub.

## WITH FULLY SPLIT CLAMPING HUB

### 15 - 4,000 Nm



### ABOUT

#### FEATURES

- ▶ radial mounting possible
- ▶ easy installation onto pre-aligned shafts
- ▶ low moment of inertia

#### DESIGN

Two split clamping hubs with two screws in each. Brief overloads of up to 1.5x the rated torque are acceptable.

#### MATERIAL

- ▶ **Bellows:** high grade stainless steel
- ▶ **Hubs:** see table

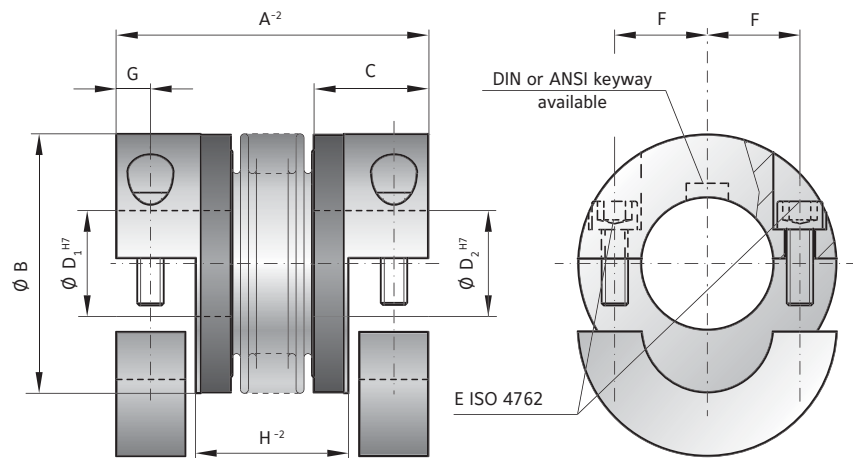

## MODEL BKH

SIZE		15	30	60	80	150	200	300	500	800	1500	4000								
Rated torque (Nm)	$T_{KN}$	15	30	60	80	150	200	300	500	800	1500	4000								
Overall length (mm)	$A^{-2}$	59   66	69   77	83   93	94   106	95   107	105   117	111   125	133   146	140   166	225									
Outside diameter (mm)	B	49	55	66	81	81	90	110	124	134	157	200								
Fit length (mm)	C	22	27	31	36	36	41	43	51	45	55	85								
Inside diameter possible from $\emptyset$ to $\emptyset$ H7 (mm)	$D_1/D_2$	8-28	10-30	12-35	14-42	19-42	22-45	24-60	35-60	40-75	50-80	50-90								
Fastening screw ISO 4762	E	M5	M6	M8	M10	M10	M12	M12	M16	M16	M20	M24								
Tightening torque of the fastening screw (Nm)		8	15	40	50	70	120	130	200	250	470	1200								
Distance between centerlines (mm)	F	17	19	23	27	27	31	39	41	48	55	65								
Distance (mm)	G	6.5	7.5	9.5	11	11	12.5	13	16.5	18	22.5	28								
Distance (mm)	$H^{-2}$	29   36	35   43	41   51	47   59	48   60	51   63	55   69	62   75	65.5   71	107									
Moment of inertia ( $10^{-3}$ kgm <sup>2</sup> )	$J_{ges}$	0.07   0.08	0.14   0.15	0.23   0.26	0.65   0.67	2.5   3.2	4.5   5.4	8.5   10.5	17.3   19.6	24.3	49.2	165								
Hub material		Al optional steel	Al optional steel	Al optional steel	Al optional steel	steel optional AL	steel optional AL	steel optional AL	steel optional AL	steel	steel	steel								
Approximate weight (kg)		0.15	0.3	0.4	0.8	1.7	2.5	4	7.5	7	12	28								
Torsional stiffness ( $10^3$ Nm/rad)	$C_t$	20   15	39   28	76   55	129   85	175   110	191   140	450   350	510   500	780	1304	3400								
Axial $\pm$ (mm)	Max. values	1	2	1	2	1.5	2	2	3	2	3	2.5	3.5	3.5	3.5					
Lateral $\pm$ (mm)		0.15	0.2	0.2	0.25	0.2	0.25	0.2	0.25	0.3	0.25	0.3	0.35	0.35	0.35	0.4				
Angular $\pm$ (degree)		1	1.5	1	1.5	1	1.5	1	1.5	1	1.5	1	1.5	1.5	1.5	1.5				
Axial spring stiffness (N/mm)	$C_a$	25	15	50	30	72	48	48	32	82	52	90	60	105	71	70	48	100	320	565
Lateral spring stiffness (N/mm)	$C_r$	475	137	900	270	1200	420	920	290	1550	435	2040	610	3750	1050	2500	840	2000	3600	6070

ORDERING EXAMPLE	BK2 / BKH	80	94	20	22.23	XX
Model	●					
Size		●				
Overall length mm			●			Special designation only (e.g. anodized hubs).
Bore D1 H7				●		
Bore D2 H7					●	
For custom features place an XX at the end of the part number and describe the special requirements (e.g. BKH/80/94/20/22.23/XX; XX=finely balanced for 25,000 rpm)						

# BKL

## WITH CLAMPING HUB 2 - 500 Nm



### ABOUT

#### FEATURES

- ▶ easy to mount
- ▶ light weight and low moment of inertia
- ▶ economical design

#### DESIGN

Two clamping hubs concentrically mounted to flexible bellows. Brief overloads of up to 1.5x the rated torque are acceptable.

#### MATERIAL

- ▶ **Bellows:** high grade stainless steel
- ▶ **Hubs:** see table

**Optional:** self-opening clamp system to open the bore during installation and removal by backing out the clamping screw.

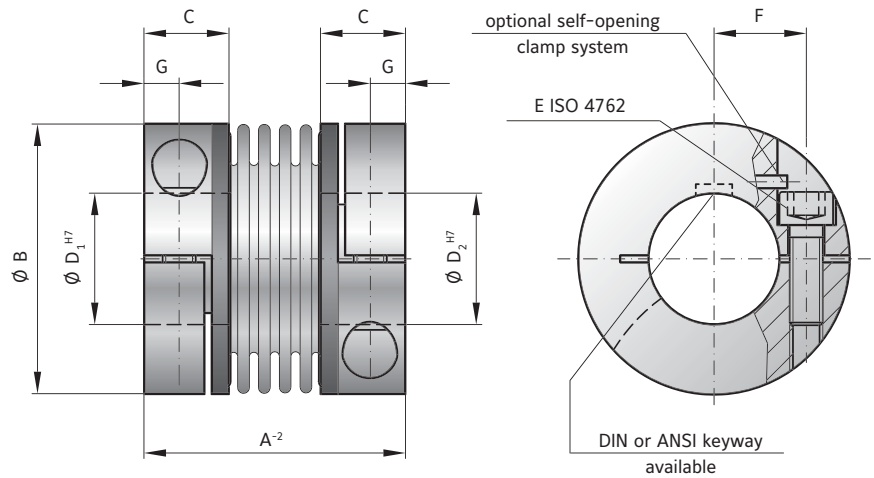

## MODEL BKL

SIZE			2	4.5	10	15	30	60	80	150	300	500
Rated torque (Nm)	$T_{KN}$		2	4.5	10	15	30	60	80	150	300	500
Overall length (mm)	$A^{-2}$		30	40	44	58	68	79	92	92	109	114
Outside diameter (mm)	B		25	32	40	49	56	66	82	82	110	123
Fit length (mm)	C		10.5	13	13	21.5	26	28	32.5	32.5	41	42.5
Inside diameter possible from $\emptyset$ to $\emptyset$ H7 (mm)	$D_{1/2}$		4-12.7	6-16	6-24	8-28	10-32	14-35	16-42	19-42	24-60	35-62
Fastening screw ISO 4762			M3	M4	M4	M5	M6	M8	M10	M10	M12	M16
Tightening torque of the fastening screw (Nm)	E		2.3	4	4.5	8	15	40	70	85	120	200
Distance between centerlines (mm)	F		8	11	14	17	20	23	27	27	39	41
Distance (mm)	G		4	5	5	6.5	7.5	9.5	11	11	13	17
Moment of inertia ( $10^{-3}$ kgm <sup>2</sup> )	$J_{ges}$		0.002	0.007	0.016	0.065	0.12	0.3	0.75	1.8   0.8	7.5   3.1	11.7   4.9
Hub material			AL optional steel	AL optional steel	AL optional steel	AL optional steel	AL optional steel	AL optional steel	AL optional steel	steel optional AL	steel optional AL	steel optional AL
Approximate weight (kg)			0.02	0.05	0.06	0.16	0.25	0.4	0.7	1.7   0.75	3.8   1.6	4.9   2.1
Torsional stiffness ( $10^3$ Nm/rad)	$C_T$		1.5	7	9	23	31	72	80	141	157	290
Axial $\pm$ (mm)		Max. values	0.5	1	1	1	1	1.5	2	2	2	2.5
Lateral $\pm$ (mm)			0.2	0.2	0.2	0.2	0.2	0.2	0.2	0.2	0.2	0.2
Angular $\pm$ (degree)			1	1	1	1	1	1	1	1	1	1
Axial spring stiffness (N/mm)	$C_s$		8	35	30	30	50	67	44	77	112	72
Lateral spring stiffness (N/mm)	$C_r$		50	350	320	315	366	679	590	960	2940	1450

ORDERING EXAMPLE	BKL	80	26	22.23	XX
Model	●				
Size		●			
Bore D1 H7			●		
Bore D2 H7				●	
For custom features place an XX at the end of the part number and describe the special requirements (e.g. BKL/80/26/22.23/XX; XX=finely balanced for 25,000 rpm)					





# WITH STAINLESS STEEL CLAMPING HUB

15 - 500 Nm

## ABOUT

### FEATURES

- ▶ for high temperatures and aggressive media
- ▶ compact design
- ▶ easy to mount

### MATERIAL

- ▶ **Bellows:** high grade stainless steel
- ▶ **Hubs:** high grade stainless steel

- ▶ **Screws:** Grade 12.9 Geomet coated (alternate materials on request)

### DESIGN

Two clamping hubs concentrically mounted to flexible bellows. Brief overloads of up to 1.5x the rated torque are acceptable. From -40° to +300°C operating temperature.



**Optional:** self-opening clamp system to open the bore during installation and removal by backing out the clamping screw.

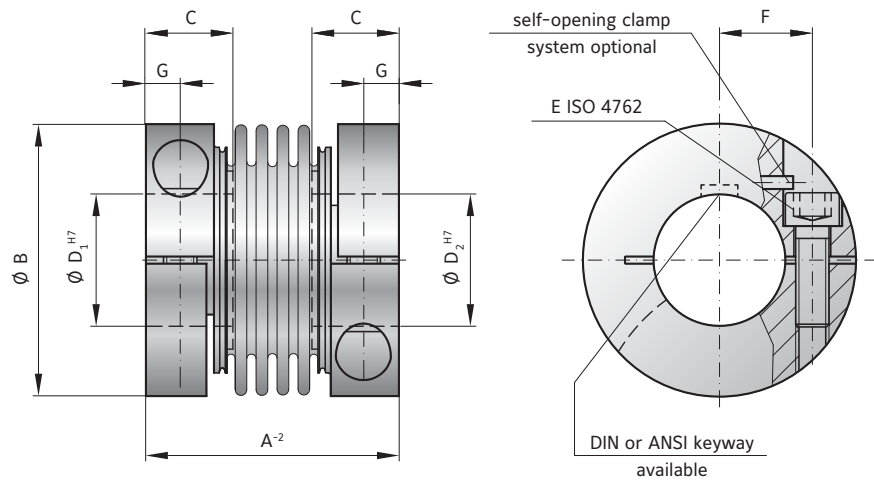

BELLOWS COUPLINGS BK

## MODEL BKS

SIZE			15	30	60	150	300	500
Rated torque (Nm)	$T_{KN}$		15	30	60	150	300	500
Overall length (mm)	$A^2$		45	52	66	76	89	95
Outside diameter (mm)	B		49	56	66	82	110	123
Fit length (mm)	C		17	20	24	30	34	35
Inside diameter* possible from $\emptyset$ to $\emptyset$ H7 (mm)	$D_1/D_2$		12-28	14-32	16-35	19-42	24-60	32-75
Fastening screw ISO 4762			M5	M6	M8	M10	M12	M12
Tightening torque of the fastening screw (Nm)	E		8	15	40	75	120	125
Distance between centerlines (mm)	F		17.5	20	23	27	39	45
Distance (mm)	G		6	7.5	9.5	11	13	13
Moment of inertia ( $10^{-3}$ kgm <sup>2</sup> )	$J_{ges.}$		0.1	0.2	0.53	1.5	5.5	8.1
Approximate weight (kg)			0.27	0.42	0.78	1.5	2.9	3.5
Torsional stiffness ( $10^3$ Nm/rad)	$C_T$		23	31	72	141	157	290
Axial $\pm$ (mm)		Max. values	1	1	1.5	2	2	2.5
Lateral $\pm$ (mm)			0.2	0.2	0.2	0.2	0.2	0.2
Angular $\pm$ (degree)			1	1	1	1	1	1
Axial spring stiffness (N/mm)	$C_a$		30	50	67	77	112	72
Lateral spring stiffness (N/mm)	$C_r$		315	366	679	960	2940	2200
Speed max. with G = 2.5 balancing (min <sup>-1</sup> )			60,000	50,500	50,000	40,500	40,000	30,000

\* Smaller bore diameter available at reduced torque capacity

ORDERING EXAMPLE	BKS	15	20	19.05	XX
Model	●				
Size		●			
Bore D1 H7			●		
Bore D2 H7				●	
For custom features place an XX at the end of the part number and describe the special requirements (e.g. BKS/15/20/19.05/XX; XX=finely balanced for 25,000 rpm)					

Special designation only (e.g. special bore tolerance).



### ABOUT

#### FEATURES

- ▶ for space restricted installations
- ▶ light weight and low moment of inertia
- ▶ easy to mount

#### DESIGN

Two clamping hubs concentrically mounted to flexible bellows.  
Brief overloads of up to 1.5x the rated torque are acceptable.

#### MATERIAL

- ▶ **Bellows:** high grade stainless steel
- ▶ **Hubs:** see table

**Optional:**  
self-opening clamp system to open the bore during installation and removal by backing out the clamping screw.

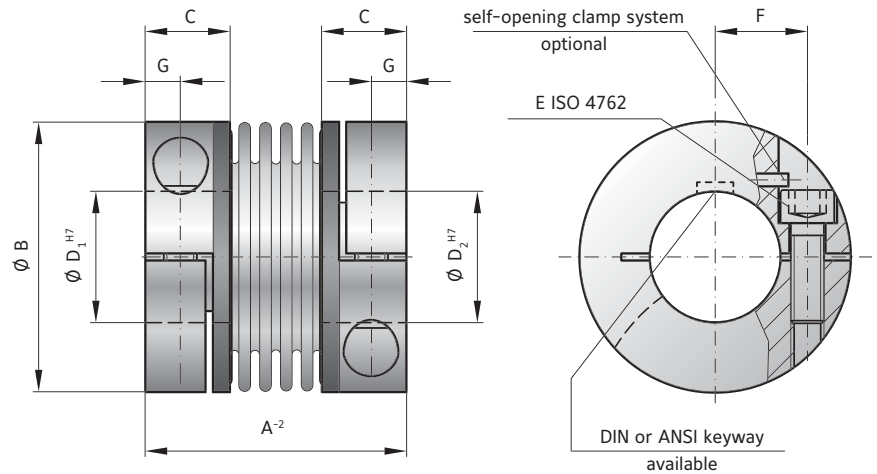

## MODEL BKC

SIZE			15	30	60	150	300	500
Rated torque (Nm)	$T_{KN}$		15	30	60	150	300	500
Overall length (mm)	$A^{-2}$		48	58	67	78	94	100
Outside diameter (mm)	B		49	56	66	82	110	123
Fit length (mm)	C		16.5	21	23	27.5	34	34
Inside diameter possible from $\emptyset$ to $\emptyset$ H7 (mm)	$D_1/D_2$		8-28	12-32	14-35	19-42	24-60	32-75
Fastening screw ISO 4762	E		M5	M6	M8	M10	M12	M12
Tightening torque of the fastening screw (Nm)			8	15	40	75	120	125
Distance between centerlines (mm)	F		17.5	20	23	27	39	45
Distance (mm)	G		6.5	7.5	9.5	11	13	13
Moment of inertia ( $10^{-3}$ kgm <sup>2</sup> )	$J_{res.}$		0.05	0.1	0.26	0.65	6.3	9
Hub material			AL	AL	AL	AL	steel	steel
Approximate weight (kg)			0.13	0.21	0.37	0.72	3.26	3.52
Torsional stiffness ( $10^3$ Nm/rad)	$C_T$		23	31	72	141	157	290
Axial $\pm$ (mm)	Max. values		1	1	1.5	2	2	2.5
Lateral $\pm$ (mm)			0.2	0.2	0.2	0.2	0.2	0.2
Angular $\pm$ (degree)			1	1	1	1	1	1
Axial spring stiffness (N/mm)	$C_a$		30	50	67	77	112	72
Lateral spring stiffness (N/mm)	$C_r$		315	366	679	960	2940	2200
Speed max. with G = 2.5 balancing ( $\text{min}^{-1}$ )			80,000	70,000	60,000	50,000	40,000	30,000

ORDERING EXAMPLE	BKC	60	26	22.23	XX
Model	●				Special designation only (e.g. special bore tolerance).
Size		●			
Bore D1 H7			●		
Bore D2 H7				●	
For custom features place an XX at the end of the part number and describe the special requirements (e.g. BKC/60/26/22.23/XX; XX=finely balanced for 25,000 rpm)					

## ULTRA COMPACT AND STIFF WITH CLAMPING HUB 20 - 1,000 Nm

### ABOUT

#### FEATURES

- ▶ extremely compact
- ▶ high torque density
- ▶ low mass and moment of inertia

#### MATERIAL

- ▶ **Bellows:** high grade stainless steel
- ▶ **Hubs:** see table

#### DESIGN

Two clamping hubs concentrically mounted to flexible bellows. Brief overloads of up to 1.5x the rated torque are acceptable.



**Key application:**  
For mounting on a torque transducer.

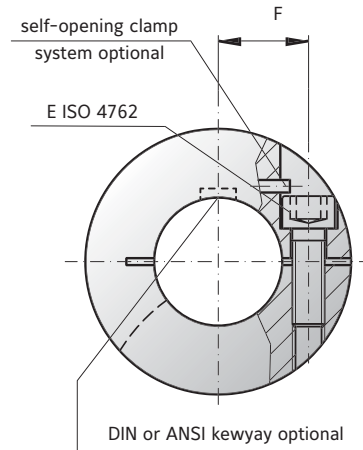
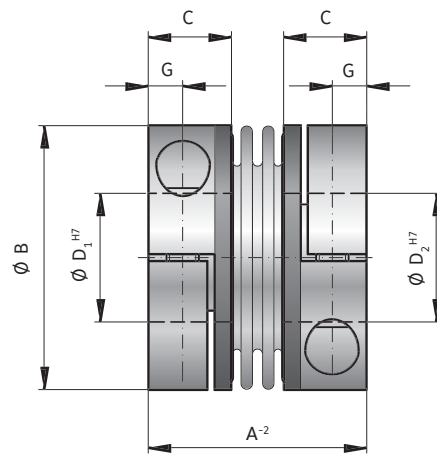
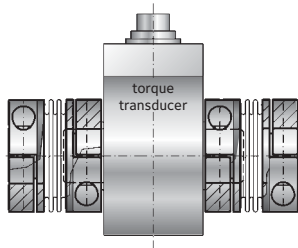

BELLOWS  
COUPLINGS BK

### MODEL BKM

SIZE			20	200	400	1000
Rated torque (Nm)	$T_{KN}$		20	200	400	1000
Overall length (mm)	$A^{-2}$		40	59	75	89
Outside diameter (mm)	B		49	66	82	110
Fit length (mm)	C		16.5	23	27.5	34
Inside diameter possible from $\emptyset$ to $\emptyset$ H7 (mm)	$D_{1/2}$		15-28	24-35	32-42	40-60
Fastening screw ISO 4762			M5	M8	M10	M12
Tightening torque of the fastening screw (Nm)	E		8	40	60	130
Distance between centerlines (mm)	F		17	23	27	39
Distance (mm)	G		6	9.5	11	13
Moment of inertia ( $10^{-3}$ kgm <sup>2</sup> )	$J_{ges.}$		0.05	0.18	0.62	7.2
Hub material			AL	AL	AL	steel
Approximate weight (kg)			0.13	0.4	0.7	3.5
Torsional stiffness ( $10^3$ Nm/rad)	$C_T$		41.9	138	170	570
Axial $\pm$ (mm)	Max. values		1	1.5	1	2
Lateral $\pm$ (mm)			0.06	0.08	0.1	0.1
Angular $\pm$ (degree)			0.5	0.5	0.5	0.5
Axial spring stiffness (N/mm)	$C_a$		55.8	153	114	148
Lateral spring stiffness (N/mm)	$C_r$		3,710	11,000	6,058	9,010
Speed max. with G = 2.5 balancing min <sup>-1</sup>			80,000	60,000	50,000	40,000

ORDERING EXAMPLE	BKM	20	20	19.05	XX
Model	●				Special designation only (e.g. special bore tolerance).
Size		●			
Bore D1 H7			●		
Bore D2 H7				●	
For custom features place an XX at the end of the part number and describe the special requirements (e.g. BKM/20/20/19.05/XX; XX=finely balanced for 25,000 rpm)					

# BK3

## WITH CONICAL CLAMPING SYSTEM

15 - 10,000 Nm

### ABOUT



#### FEATURES

- ▶ high clamping pressure
- ▶ high torque version
- ▶ modern design for removal system

#### MATERIAL

- ▶ **Bellows:** high grade stainless steel
- ▶ **Hubs:** steel

#### DESIGN

Two conical clamping hubs concentrically mounted to flexible bellows. Brief overloads of up to 1.5x the rated torque are acceptable.

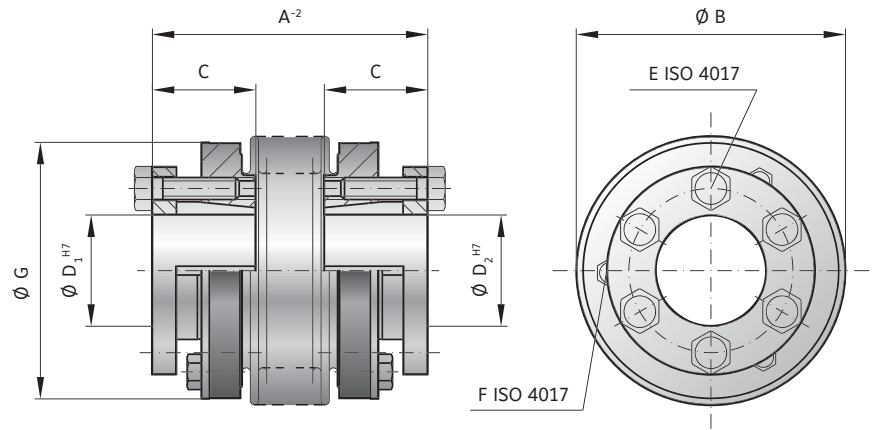

## MODEL BK3

SIZE		15	30	60	150	200	300	500	800	1500	4000	6000	10000
Rated torque (Nm)	$T_{KN}$	15	30	60	150	200	300	500	800	1500	4000	6000	10000
Overall length (mm)	$A^{-2}$	48 55	57 65	66 76	75 87	78 90	89 103	97 110	114	141	195	210	217
Outside diameter (mm)	B	49	55	66	81	90	110	124	133	157	200	253	303
Fit length (mm)	C	19	22	27	32	32	41	41	50	61	80	85	92
Inside diameter possible from $\emptyset$ to $\emptyset$ H7 (mm)	$D_{1/2}$	10-22	12-23	12-29	15-38	15-44	24-56	24-60	30-60	35-70	50-100	60-140	70-180
Fastening screw ISO 4017	E	6 x M4	6 x M5	6 x M5	6 x M6	6 x M6	6 x M8	6 x M8	6 x M10	6 x M12	6 x M16	6 x M16	8 x M16
Tightening torque of the fastening screw (Nm)		4	6	8	12	14	18	25	40	70	120	150	160
Jack screw ISO 4017	F	3 x M4	3 x M4	3 x M5	3 x M5	3 x M6	3 x M6	3 x M6	3 x M8	6 x M8	6 x M10	6 x M10	8 x M10
Outside diameter of hub (mm)	G	49	55	66	81	90	110	122	116	135	180	246	295
Moment of inertia ( $10^{-3}$ kgm <sup>2</sup> )	$J_{ges}$	0.07 0.08	0.15 0.16	0.39 0.41	1.2 1.6	1.7 2.5	5.1 5.9	9.1 9.9	13.2	34.9	85.5	254	629
Approximate weight (kg)		0.25	0.4	0.7	1.2	1.8	3	4.2	5.6	8.2	23	32.6	45.5
Torsional stiffness ( $10^3$ Nm/rad)	$C_T$	20 15	39 28	76 55	175 110	191 140	450 350	510 500	780	1304	3400	5700	10950
Axial $\pm$ (mm)	Max. values	1 2	1 2	1.5 2	2 3	2 3	2.5 3.5	2.5 3.5	3.5	3.5	3.5	3	3
Lateral $\pm$ (mm)		0.15 0.2	0.2 0.25	0.2 0.25	0.2 0.25	0.25 0.3	0.25 0.3	0.3 0.35	0.35	0.35	0.4	0.4	0.4
Angular $\pm$ (degree)		1 1.5	1 1.5	1 1.5	1 1.5	1 1.5	1 1.5	1 1.5	1 1.5	1.5	1.5	1.5	1.5
Axial spring stiffness (N/mm)	$C_s$	25 15	50 30	72 48	82 52	90 60	105 71	70 48	100	320	565	1030	985
Lateral spring stiffness (N/mm)	$C_r$	475 137	900 270	1200 420	1500 435	2040 610	3750 1050	2500 840	2000	3600	6070	19200	21800

ORDERING EXAMPLE	BK3	60	76	20	22.23	XX
Model	●					Special designation only (e.g. non-standard bore tolerance)
Size		●				
Overall length mm			●			
Bore D1 H7				●		
Bore D2 H7					●	
For custom features place an XX at the end of the part number and describe the special requirements (e.g. BK3/60/76/20/22.23/XX; XX=K6 bore tolerance on D1)						

# BK4

## FOR TAPERED SHAFTS

15 - 150 Nm



### ABOUT

#### FEATURES

- ▶ for tapered shafts
- ▶ easy to mount and dismount
- ▶ high installed concentricity

#### MATERIAL

- ▶ **Bellows:** high grade stainless steel
- ▶ **Hubs:** steel

#### DESIGN

Conical clamping system opposite 1:10 tapered bore with feather keyway. Brief overloads of up to 1.5x the rated torque acceptable.

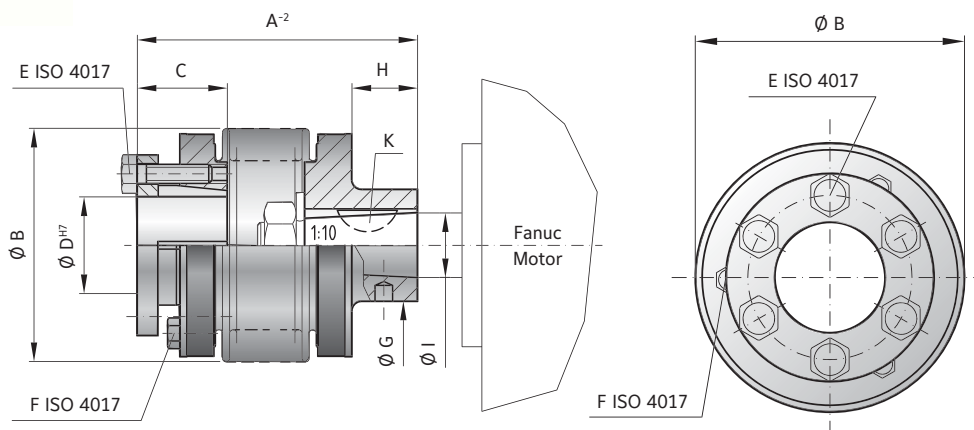

BELLOWS COUPLINGS BK

## MODEL BK4

SIZE		15		30		60		150	
Rated torque (Nm)	T <sub>KN</sub>	15		30		60		150	
Overall length (mm)	A <sup>-2</sup>	47	54	68	76	72	82	82	94
Outside diameter (mm)	B	49		55		66		81	
Fit length (mm)	C	19		22		27		32	
Inside diameter possible from Ø to Ø H7 (mm)	D	10-22		12-23		12-29		15-37	
Fastening screw ISO 4017	E	6 x M4		6 x M5		6 x M5		6 x M6	
Tightening torque of the fastening screw (Nm)		4		6		8		12	
Jack screw ISO 4017	F	3 x M4		3 x M4		3 x M5		3 x M5	
Outside diameter of hub (mm)	G	20		27		30		30	
Hub length (mm)	H	8.5		22		18		20	
Moment of inertia (10 <sup>-3</sup> kgm <sup>2</sup> )	J <sub>ges</sub>	0.10	0.12	0.22	0.27	0.58	0.61	1.1	1.4
Approximate weight (kg)		0.25		0.4		0.8		1.35	
Torsional stiffness (10 <sup>3</sup> Nm/rad)	C <sub>T</sub>	20	15	39	28	76	55	175	110
Axial ± (mm)	Max. values	1	2	1	2	1.5	2	2	3
Lateral ± (mm)		0.15	0.2	0.2	0.25	0.2	0.25	0.2	0.25
Angular ± (degree)		1	1.5	1	1.5	1	1.5	1	1.5
Axial spring stiffness (N/mm)	C <sub>a</sub>	25	15	50	30	72	48	82	52
Lateral spring stiffness (N/mm)	C <sub>r</sub>	475	137	900	270	1200	420	1500	435
Cone Ø (Fanuc-Motor) (mm)	I	11		16		16		16	
Key width (mm)	K	4		5		5		5	

ORDERING EXAMPLE	BK4	150	82	20	XX
Model	●				Special designation only (e.g. non-standard bore tolerance)
Size		●			
Overall length mm			●		
Bore D1 H7				●	
For custom features place an XX at the end of the part number and describe the special requirements (e.g. BK4/150/82/20/XX; XX=finely balanced for 25,000 rpm)					

# BK5

## BLIND MATE WITH CLAMPING HUB 15 - 1,500 Nm

### ABOUT

#### FEATURES

- ▶ easy installation and removal
- ▶ electrically and thermally isolating
- ▶ absolutely backlash free assembly

#### MATERIAL

- ▶ **Bellows:** high grade stainless steel
- ▶ **Hubs:** up through size 80 Aluminum, size 150 and up steel

- ▶ **Tapered male segment:** high strength plastic

#### DESIGN

Two clamping hubs, one of which has a tapered male projection for blind mate connection. Brief overloads of up to 1.5x the rated torque are acceptable.

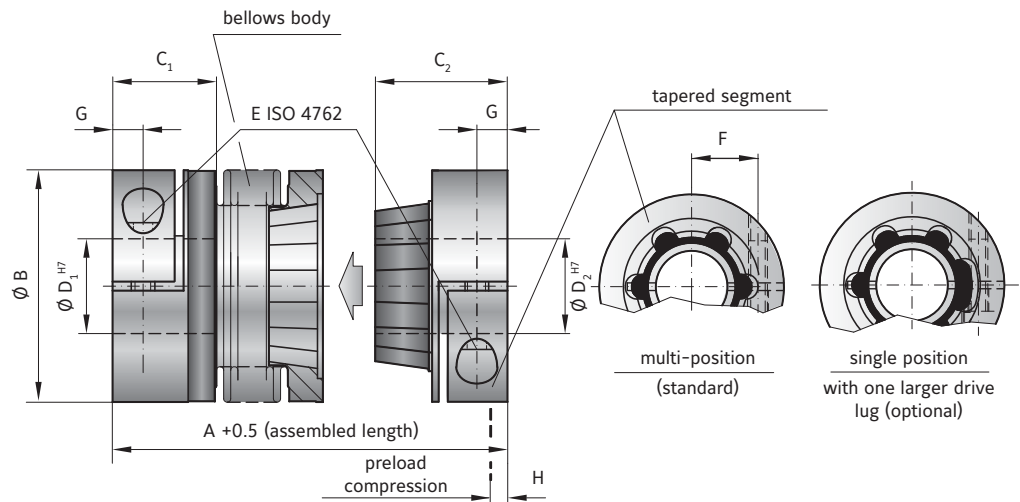

### MODEL BK5

SIZE			15	30	60	80	150	300	500	800	1500
Rated torque (Nm)	$T_{KN}$		15	30	60	80	150	300	500	800	1500
Overall length (inserted) (mm)	$A^{+0.5}$		60, 67	71, 79	85, 95	94, 106	95, 107	114, 128	136, 149	150, 172	
Outside diameter (mm)	B		49	55	66	81	81	110	124	133	157
Fit length (mm)	$C_1$		22	27	32	36	36	43	51	45	55
Fit length (mm)	$C_2$		28	33	39	43	43	52	61	74	94
Inside diameter possible from $\emptyset$ to $\emptyset$ H7 (mm)	$D_1$		8-28	10-30	12-32	14-42	14-42	24-60	35-60	40-75	50-80
Inside diameter possible from $\emptyset$ to $\emptyset$ H7 (mm)	$D_2$		8-22	10-25	12-32	14-38	14-38	24-58	35-60	40-62	50-75
Fastening screw ISO 4762	E		M5	M6	M8	M10	M10	M12	M16	2 x M16**	2 x M20**
Tightening torque of the fastening screw (Nm)			8	15	40	50	70	130	200	250	470
Distance between centerlines (mm)	F		17	19	23	27	27	39	41	2 x 48**	2 x 55**
Distance (mm)	G		6.5	7.5	9.5	11	11	13	16.5	18	22.5
Preload compression (mm)	H		0.2 - 1.0	0.5 - 1.0	0.5 - 1.5	0.5 - 1.5	0.5 - 1.5	0.5 - 1.5	1.0 - 2.0	1.0 - 2.5	0.5 - 1.5
Axial recovery force at maximum pretensioning (N)			20, 12	50, 30	70, 45	48, 32	82, 52	157, 106	140, 96	200, 650	
Moment of inertia ( $10^{-3}$ kgm <sup>2</sup> )	$J_{res}$		0.07, 0.08	0.14, 0.15	0.23, 0.26	0.65, 0.67	2.2, 2.4	7.4, 7.9	13.7, 14.4	26.2, 51.4	
Approximate weight (kg)			0.1, 0.1	0.3, 0.3	0.4, 0.4	0.9, 0.9	1.8, 1.8	4, 4	6.5, 6.7	8.2, 15.3	
Torsional stiffness ( $10^3$ Nm/rad)	$C_t$		10, 8	20, 14	38, 28	65, 43	88, 55	225, 175	255, 245	400, 650	
Axial* $\pm$ (mm)	Max. values		0.5, 1	0.5, 1	0.5, 1	1, 1	2, 1	2, 1.5	2, 2.5	3.5, 3	2
Lateral $\pm$ (mm)			0.15, 0.2	0.2, 0.25	0.2, 0.25	0.2, 0.25	0.2, 0.25	0.2, 0.25	0.25, 0.3	0.3, 0.35	0.35, 0.35
Angular $\pm$ (degree)			1, 1.5	1, 1.5	1, 1.5	1, 1.5	1, 1.5	1, 1.5	1, 1.5	1, 1.5	1.5, 1.5
Lateral spring stiffness (N/mm)	$C_r$		475, 137	900, 270	1200, 420	920, 290	1550, 435	3750, 1050	2500, 840	2000, 3600	

\*in addition to maximum allowable pretension \*\*180° opposed in each clamping hub.

ORDERING EXAMPLE	BK5	30	71	18	19	XX
Model	●					
Size		●				
Overall length mm			●			
Bore D1 H7				●		
Bore D2 H7					●	
For custom features place an XX at the end of the part number and describe the special requirements (e.g. BK5/30/71/18/19/XX; XX=finely balanced for 25,000 rpm)						

# BK6

## BLIND MATE WITH CONICAL CLAMPING RING

### 15 - 1,500 Nm

#### ABOUT



#### FEATURES

- ▶ axial mounting possible
- ▶ easy installation and removal
- ▶ naturally very well balanced due to self centering clamping ring system
- ▶ absolutely backlash free assembly

#### MATERIAL

- ▶ **Bellows:** high grade stainless steel
- ▶ **Hubs:** steel

- ▶ **Tapered male segment:** high strength plastic

#### DESIGN

Two conical clamping ring hubs, one of which has a tapered male projection for blind mate connection. Brief overloads of up to 1.5x the rated torque are acceptable.

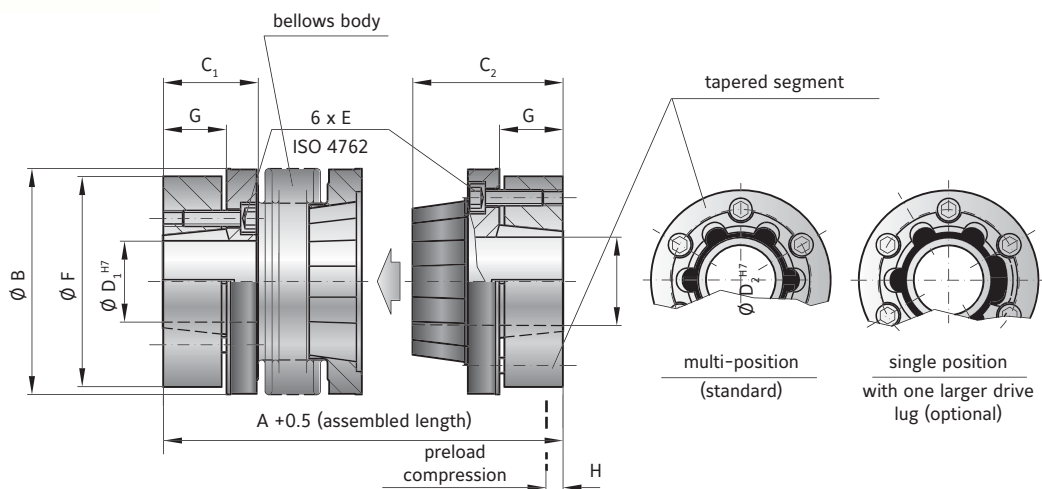

## MODEL BK6

SIZE			15	30	60	150	300	500	800	1500
Rated torque (Nm)	$T_{KN}$		15	30	60	150	300	500	800	1500
Overall length (gesteckt) (mm)	$A^{+0.5}$		58, 65	68, 76	79, 89	97, 109	113, 127	132, 145	140, 158	
Outside diameter (mm)	B		49	55	66	81	110	124	133	157
Fit length (mm)	$C_1$		13.5	16.5	18	23.5	27	32	42	53
Fit length (mm)	$C_2$		29	34	39	49.5	59	68	74	90.5
Inside diameter possible from $\emptyset$ to $\emptyset$ H7 (mm)	$D_1$		10-22	12-24	12-32	15-40	24-56	30-60	40-62	50-75
Inside diameter possible from $\emptyset$ to $\emptyset$ H7 (mm)	$D_2$		10-22	12-24	12-32	15-40	24-56	30-60	40-62	50-75
Fastening screw ISO 4762			M4	M5	M5	M6	M8	M8	M10	M12
Tightening torque of the fastening screw (Nm)	E		3.5	6.5	8	12	30	32	55	110
Diameter of clamping ring (mm)	F		46.5	51	60	74	102	114	126	146
Clamping ring length (mm)	G		9.5	10.5	11.5	17.5	20	23	27	32
Preload compression (mm)			0.2 - 1.0	0.5 - 1.0	0.5 - 1.5	0.5 - 1.5	0.5 - 1.5	1.0 - 2.0	1.0 - 2.0	0.5 - 1.5
Axial recovery force at maximum pretensioning (N)	H		20, 12	50, 30	70, 45	82, 52	157, 106	140, 96	400, 250	650, 400
Moment of inertia ( $10^{-3}$ kgm <sup>2</sup> )	$J_{ges}$		0.1, 0.12	0.2, 0.25	0.4, 0.45	2.0, 2.5	5.4, 6.1	8.4, 9.1	19.5, 15	44, 30
Approximate weight (kg)			0.3, 0.32	0.5, 0.52	0.82, 0.84	1.6, 1.7	4.1, 4.2	6.0, 6.3	9.4, 9.4	16.2, 16.2
Torsional stiffness ( $10^3$ Nm/rad)	$C_T$		10, 8	20, 14	38, 28	88, 55	225, 175	255, 245	400, 400	660, 660
Axial* $\pm$ (mm)			0.5, 1	0.5, 1	0.5, 1	1, 1	2, 1.5	2, 2.5	3.5, 3	2, 2
Lateral $\pm$ (mm)	Max. values		0.15, 0.2	0.2, 0.25	0.2, 0.25	0.2, 0.25	0.25, 0.3	0.3, 0.35	0.35, 0.35	0.35, 0.35
Angular $\pm$ (degree)			1, 1.5	1, 1.5	1, 1.5	1, 1.5	1, 1.5	1, 1.5	1.5, 1.5	1.5, 1.5
Lateral spring stiffness (N/mm)	$C_r$		475, 137	900, 270	1200, 420	1550, 435	3750, 1050	2500, 840	2000, 2000	3600, 3600

\* in addition to maximum allowable pretension

Higher torques upon request

ORDERING EXAMPLE	BK6	30	76	18	19	XX
Model	●					
Size		●				
Overall length mm			●			
Bore D1 H7				●		
Bore D2 H7					●	
For custom features place an XX at the end of the part number and describe the special requirements (e.g. BK6/30/76/18/19/XX; XX=finely balanced for 25,000 rpm)						

**BK7**

# WITH EXPANDING SHAFT

## 15 - 300 Nm



### ABOUT

#### FEATURES

- ▶ for hollow shaft mounting
- ▶ short design saves installation space
- ▶ solution for mismatched shaft / bore

#### MATERIAL

- ▶ **Bellows:** high grade stainless steel
- ▶ **Hubs:** see table
- ▶ **Expanding mandrel system:** steel

#### DESIGN

One clamping hub on one end with an expanding shaft on the other end. Brief overloads of up to 1.5x the rated torque are acceptable.

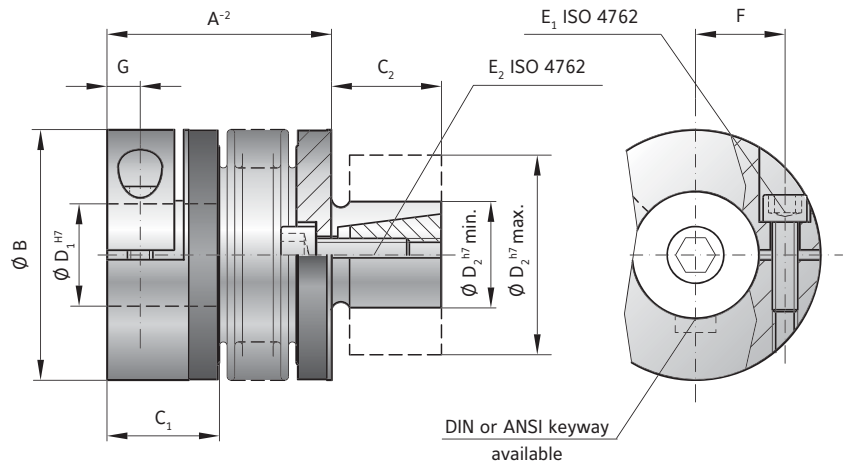

## MODEL BK7

SIZE		15		30		60		150		300		
Rated torque	(Nm)	$T_{KN}$	15	30	60	150	300					
Overall length	(mm)	$A^{-2}$	45	52	53	61	62	72	71	83	84	98
Outside diameter	(mm)	B	49	55	66	81	110					
Fit length	(mm)	$C_1$	22	27	32	36	43					
Fit length	(mm)	$C_2$	20	25	27	32	45					
Inside diameter possible from $\emptyset$ to $\emptyset$ H7	(mm)	$D_1$	8-28	10-30	12-35	19-42	30-60					
Shaft diameter from $\emptyset$ to $\emptyset$ h7	(mm)	$D_2$	13-25	14-30	23-38	26-42	38-60					
Fastening screw ISO 4762		$E_{1/2}$	M5	M6	M8	M10	M12					
Tightening torque of the fastening screw	(Nm)	$E_{1/2}$	8	14	38	65	120					
Distance between centerlines	(mm)	F	17	19	23	27	39					
Distance	(mm)	G	6.5	7.5	9.5	11	13					
Moment of inertia ( $10^{-3}$ kgm <sup>2</sup> )		$J_{ges}$	0.07	0.08	0.14	0.15	0.23	0.26	2.2	2.4	6.5	8.9
Hub material			Al	Al	Al	steel	steel					
Approximate weight	(kg)		0.15	0.3	0.4	1.7	4					
Torsional stiffness ( $10^3$ Nm/rad)		$C_T$	20	15	39	28	76	55	175	110	450	350
Axial $\pm$ (mm)		Max. values	1	2	1	2	1.5	2	2	3	2.5	3.5
Lateral $\pm$ (mm)			0.15	0.2	0.2	0.25	0.2	0.25	0.2	0.25	0.25	0.3
Angular $\pm$ (degree)			1	1.5	1	1.5	1	1.5	1	1.5	1	1.5
Axial spring stiffness	(N/mm)	$C_a$	20	12	50	30	72	48	82	52	105	71
Lateral spring stiffness	(N/mm)	$C_r$	315	108	730	230	1200	380	1550	435	3750	1050

ORDERING EXAMPLE	BK7	150	71	32	22.23	XX
Model	●					
Size		●				
Overall length mm			●			
Bore D1 H7				●		
Shaft D2 f7					●	
Special designation only (e.g. special bore tolerance).						
For custom features place an XX at the end of the part number and describe the special requirements (e.g. BK7/150/71/32/22.23/XX; XX=finely balanced for 25,000 rpm)						



**BK8**

# WITH ISO FLANGE CONNECTION

## 50 - 2,600 Nm

### ABOUT

#### FEATURES

- ▶ for ISO flange output gearboxes
- ▶ allows for continuous hollow through axis with some right angle gearbox designs
- ▶ compact design

#### MATERIAL

- ▶ **Bellows:** high grade stainless steel

- ▶ **Hubs:** up through size 300 aluminum, size 1500 and up steel
- ▶ **Adapter flange:** steel

#### DESIGN

One clamping hub on one end with an integral flange and adapter flange on the other end. Maximum transmittable torque depends on the bore diameter.

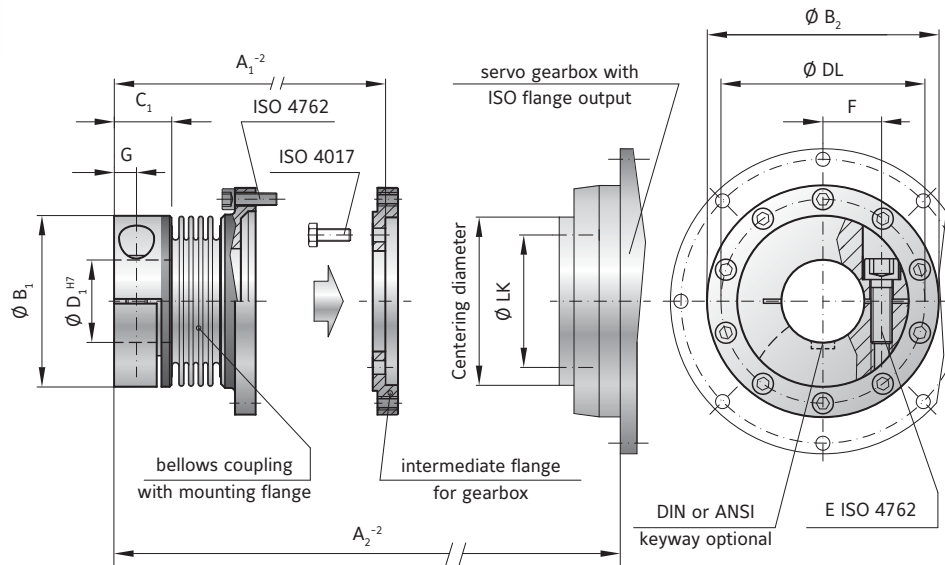

## MODEL BK8

SIZE		15	60	150	300	1500
Flange centering diameter	(mm)	40 h7	63 h7	80 h7	100 h7	160 h7
Flange bolt circle / thread $\emptyset$	(mm)	31.5 / 8 x M5	50 / 8 x M6	63 / 12 x M6	80 / 12 x M8	125 / 12 x M10
Maximum torque*	(Nm)	50	210	380	750	2600
Length -2	(mm) A <sub>1</sub>	48.5	67	72	90	140
Length -2	(mm) A <sub>2</sub>	68	97	101	128	190
Outside diameter of hub	(mm) B <sub>1</sub>	49	66	82	110	157
Flange diameter	(mm) B <sub>2</sub>	63.5	86	108	132	188
Fit length	(mm) C <sub>1</sub>	16.5	23	27.5	34	55
Inside diameter possible from $\emptyset$ to $\emptyset$ H7	(mm) D <sub>1</sub>	12-28	14-35	19-42	24-60	50-80
Hub bolt circle	(mm) DL	56.5	76	97	120	170
Fastening threads	(mm)	10 x M4	10 x M5	10 x M6	12 x M6	18 x M8
Fastening screws ISO 4762		1 x M5	1 x M8	1 x M10	1 x M12	2 x M20
Tightening torque of the fastening screw	(Nm) E <sub>1</sub>	8	45	80	120	470
Distance between centerlines	(mm) F	1 x 17.5	1 x 23	1 x 27	1 x 39	2 x 55
Distance	(mm) G	6.5	9.5	11	13	22.5
Approximate weight	(kg)	0.3	0.7	1	2.8	10
Moment of inertia	(10 <sup>-3</sup> kgm <sup>2</sup> ) J <sub>ges</sub>	0.15	0.65	1.3	5.5	45
Lateral	$\pm$ (mm)	0.25	0.25	0.25	0.25	0.25
Angular	$\pm$ (degree)	1	1	1	1	1
Axial	$\pm$ (mm)	1	1.5	2	2.5	3

\* maximum torque transmittable only for brief periods and requires maximum bore for clamping strength

ORDERING EXAMPLE	BK8	60	22.23	67	XX
Model	●				
Size		●			
Bore D1 H7			●		
Overall length mm				●	
For custom features place an XX at the end of the part number and describe the special requirements (e.g. BK8/60/22.23/67/XX; XX=anodized hubs)					

Special designation only  
(e.g. special bore tolerance).

# BK1

## WITH FLANGE MOUNTING

15 - 10,000 Nm



### ABOUT

#### FEATURES

- ▶ For simple flange mounting to special drive components
- ▶ custom flange patterns available

#### MATERIAL

- ▶ **Bellows:** high grade stainless steel

- ▶ **Hubs:** steel

#### DESIGN

Two mounting flanges concentrically assembled to the flexible bellows. Brief overloads of up to 1.5x the rated torque are acceptable.

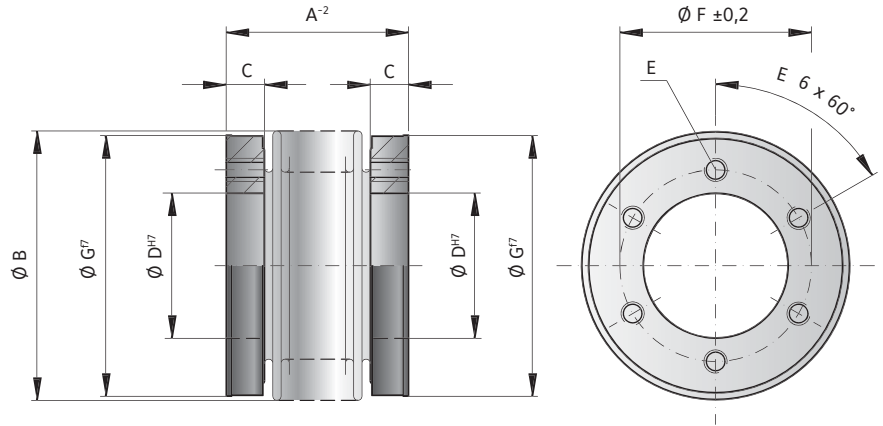

### MODEL BK1

SIZE		15	30	60	150	200	300	500	800	1500	4000	6000	10000
Rated torque (Nm)	T <sub>KN</sub>	15	30	60	150	200	300	500	800	1500	4000	6000	10000
Overall length (mm)	A <sup>2</sup>	30   37	36   44	43   53	50   62	53   65	56   70	64   77	81	100	145	138	150
Outside diameter of bellows (mm)	B	49	55	66	81	90	110	124	133	157	200	253	303
Fit length/thread depth (mm)	C	7.5	10	11	13	14.5	15	16	18	22	30	30	36
Inside diameter H7 (mm)	D	25	28	38	50	58	65	70	75	85	100	145	190
Fastening threads	E	6 x M5	6 x M5	6 x M6	6 x M6	6 x M6	6 x M8	6 x M8	6 x M10	6 x M16	6 x M20	8 x M20	8 x M24
Bolt circle diameter ± 0.2 (mm)	F	35	37	46	62	70	80	94	90	110	140	190	234
Outside diameter f7 (mm)	G	49	55	66	81	90	110	122	116	140	182	235	295
Moment of inertia (10 <sup>-3</sup> kgm <sup>2</sup> )	J <sub>ges</sub>	0.07   0.08	0.14   0.15	0.30   0.32	0.90   0.95	1.30   1.40	1.95   2.10	3.0   3.4	4.3	10.6	46	132	350
Approximate weight (kg)		0.15	0.2	0.3	0.6	0.8	1.35	1.8	1.9	3.3	8.9	13.9	23.7
Torsional stiffness (10 <sup>3</sup> Nm/rad)	C <sub>T</sub>	20   15	39   28	76   55	175   110	191   140	450   350	510   500	780	1304	3400	5700	10950
Axial ± (mm)	Max. values	1   2	1   2	1.5   2	2   3	2   3	2.5   3.5	2.5   3.5	3.5	3.5	3.5	3	3
Lateral ± (mm)		0.15   0.2	0.2   0.25	0.2   0.25	0.2   0.25	0.25   0.3	0.25   0.3	0.3   0.35	0.35	0.35	0.4	0.4	0.4
Angular ± (degree)		1   1.5	1   1.5	1   1.5	1   1.5	1   1.5	1   1.5	1   1.5	1   1.5	1.5	1.5	1.5	1.5
Axial spring stiffness (N/mm)	C <sub>s</sub>	25   15	50   30	72   48	82   52	90   60	105   71	70   48	100	320	565	1030	985
Lateral spring stiffness (N/mm)	C <sub>r</sub>	475   137	900   270	1200   420	1550   435	2040   610	3750   1050	2500   840	2000	3600	6070	19200	21800

ORDERING EXAMPLE	BK1	150	62	XX
Model	●			
Size		●		
Overall length mm			●	
Special designation only (e.g. high speed balancing).				
For custom features place an XX at the end of the part number and describe the special requirements (e.g. BK1/150/62/XX; XX=finely balanced for 25,000 rpm)				



# SPECIAL SOLUTIONS

2 - 10,000 Nm

## CUSTOMER SPECIFIC FEATURES

---

Including:

- ▶ Special materials and treatments
- ▶ Custom bellows
- ▶ Specific overall length
- ▶ Internal catches for in case of bellows rupture
- ▶ Many more

Contact us by phone at 1-630-521-9911

