

The information in this section has been superseded.  
Please see the information in the latest product catalog at:  
[www.animatics.com/support/moog-animatics-catalog.html](http://www.animatics.com/support/moog-animatics-catalog.html)

# D-Style Motor Comparison Chart

OVERVIEW

SOFTWARE

D-STYLE MOTORS

D-STYLE CONNECTIVITY

PERIPHERALS

M-STYLE MOTORS

M-STYLE CONNECTIVITY

LINEAR SYSTEMS

POWER SUPPLIES & SHUNTS

GEAR HEADS

APPENDIX

The information in this section has been superseded.  
Please see the information in the latest product catalog at:  
[www.animatics.com/support/moog-animatics-catalog.html](http://www.animatics.com/support/moog-animatics-catalog.html)

The information in this section has been superseded.  
Please see the information in the latest product catalog at:  
[www.animatics.com/support/moog-animatics-catalog.html](http://www.animatics.com/support/moog-animatics-catalog.html)

The information in this section has been superseded.  
Please see the information in the latest product catalog at:  
[www.animatics.com/support/moog-animatics-catalog.html](http://www.animatics.com/support/moog-animatics-catalog.html)

The information in this section has been superseded.  
Please see the information in the latest product catalog at:  
[www.animatics.com/support/moog-animatics-catalog.html](http://www.animatics.com/support/moog-animatics-catalog.html)

# Now With CAN Bus through D-Sub Connector



- Get your SmartMotor with CAN & brake
- More compact design decreases required space in machine
- Low cost OEM means of connecting CAN through the DB15 connector

## Example SmartMotor Part Numbers Compatible with New –CDS Option\*

- SM23165D-CDS
- SM23165DT-CDS
- SM23165D-BRK-CDS
- SM23165DT-BRK-CDS
- SM23165D-CDS-AD1
- SM23165DT-CDS-AD1
- SM23165D-DE-CDS
- SM23165DT-DE-CDS
- SM23165D-DEBRK-CDS
- SM23165DT-DEBRK-CDS
- SM23165D-DE-CDS-AD1
- SM23165DT-DE-CDS-AD1
- SM34165D-CDS
- SM34165D-DE-CDS
- SM34165D-BRK-CDS
- SM34165D-DEBRK-CDS
- SM34165D-DE-CDS-AD1
- SM34165DT-DE-CDS-AD1

\*Consult the factory for the complete list.

PIN	I/O CONNECTOR (5VTTL I/O)	Specifications:	
1	I/O – 0 General Purpose or Enc. A or Step Input	25mAmp Sink or Source 10Bit 0-5VDC A/D	1.5MHz max as Enc or Step input
2	I/O – 1 General Purpose or Enc. B or Dir. Input	25mAmp Sink or Source 10Bit 0-5VDC A/D	1.5MHz max as Enc or Dir. Input
3	I/O – 2 Positive Over Travel or GP	25mAmp Sink or Source 10Bit 0-5VDC A/D	
4	I/O – 3 Negative Over Travel or GP	25mAmp Sink or Source 10Bit 0-5VDC A/D	
5	I/O – 4 General Purpose or RS-485 A Channel(1)	25mAmp Sink or Source 10Bit 0-5VDC A/D	115.2KBaud Max
6	I/O – 5 General Purpose or RS-485 B Channel(1)	25mAmp Sink or Source 10Bit 0-5VDC A/D	115.2KBaud Max
7	I/O – 6 General Purpose or "G" command	25mAmp Sink or Source 10Bit 0-5VDC A/D	Redundant connection on Main Power Connector
8	Phase A Encoder Output		
9	Phase B Encoder Output		
10	CAN-Low	1MBaud (max, non-isolated)	115.2KBaud Max
11	CAN-Hi	1MBaud (max, non-isolated)	115.2KBaud Max
12	+5VDC Out	50mAmps Max (total)	
13	SIG Ground		
14	Ground		
15	Main Power: +20-48VDC	if -DE option, control power separate from main power	

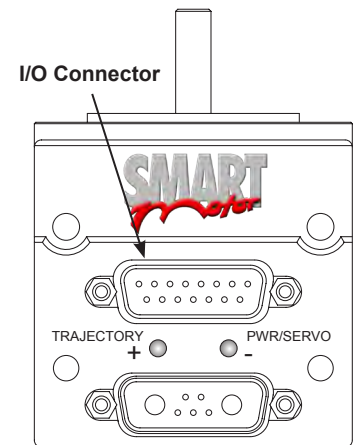

DB-15 D-sub Connector

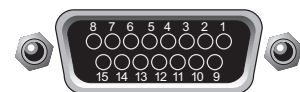

**WARNING: Proper bus biasing and termination must be incorporated into system wiring to ensure quality communications over any industrial bus. Failure to do so could result in loss of communications. Please consult the associated bus standard organizations for details.**

Moog Animatics is releasing a new option to their popular NEMA 23 frame SmartMotors, the SM23165D-CDS and SM23165DT-CDS.



This motor option allows users to employ CAN communications through the D-sub connector on the top of the motor instead of through the 5-pin connector on the back of the motor. This change allows for the integrated brake option to be used with CAN, opening the door to

numerous applications requiring SmartMotor on their vertical axis.

SmartMotor products from Moog Animatics are advanced motion controllers with an integrated servo motor, drive and encoder inside one package. Each SmartMotor is able to be a slave or a master with the ability to link over 120 SmartMotors together over one CAN bus.



NOTE: 24V CAN bus power connection is not required at the motor. DeviceNet bus power monitor and fault are overridden and bypassed.

**LED Indications are as standard Class 5 D-style SmartMotors with added indications for CAN bus condition.**

Condition	Indication
Bt=0, CAN bus OK, Bt=1, CAN bus OK,	Trajectory LED = OFF Trajectory LED = GREEN
Bt=0, CAN bus fault Bt=1, CAN bus fault	Trajectory LED = Red flashing Trajectory LED = Red/Green alternating

**Bt refers to Busy Trajectory Status Bit. When the motor is actively pursuing a trajectory, the Bt bit will be set to 1.**

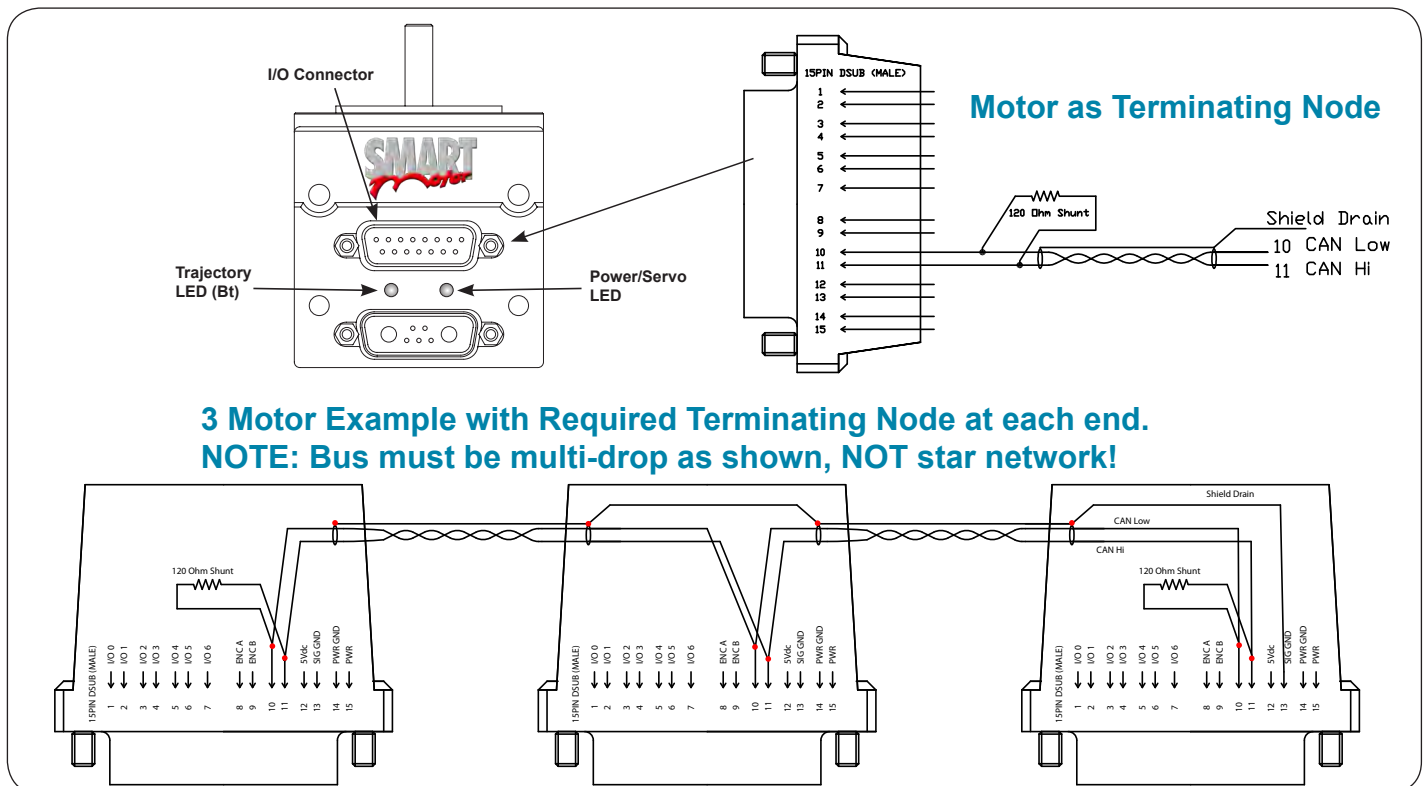

# Recommended DE Option

The information in this section has been superseded.  
Please see the information in the latest product catalog at:  
[www.animatics.com/support/moog-animatics-catalog.html](http://www.animatics.com/support/moog-animatics-catalog.html)

OVERVIEW

SOFTWARE

D-STYLE MOTORS

D-STYLE CONNECTIVITY

PERIPHERALS

M-STYLE MOTORS

M-STYLE CONNECTIVITY

LINEAR SYSTEMS

POWER SUPPLIES & SHUNTS

GEAR HEADS

APPENDIX



SM17205D		
Continuous Torque	2.08	in-lb
	33	oz-in
	0.24	N-m
Peak Torque	3.82	in-lb
	61	oz-in
	0.43	N-m
Nominal Continuous Power	145	Watt
No Load Speed	7,900	RPM
Max. Continuous Current* @ 6000 RPM	3.81	Amps
Peak Power @ 4200 RPM	185	Watts
Voltage Constant	6.506	V/kRPM
Inductance	1.4	mH
Encoder Resolution	4,000	Counts/Rev
Rotor Inertia	0.00217	oz-in-sec <sup>2</sup>
	1.5325	10 <sup>-5</sup> Kg-m <sup>2</sup>
Weight	1.2	lb
	0.55	kg
Shaft Diameter	0.197	in
	5.00	mm
Shaft, Radial Load	7	lb
	3.18	kg
Shaft, Axial Thrust Load	3	lb
	1.36	kg
DeviceNet Available	Yes	
PROFIBUS Available		
CANopen Available	Yes	

\*Default voltage is 48V. See graphs for additional voltages.



Operating temperature range: 0°C–85°C  
Storage temperature range: -10°C–85°C, noncondensing

**NOTE: Motor specifications are subject to changes without notice. Consult website and factory for latest data.**



## Moog Animatics SmartMotor™ SM17205D (No Options) CAD Drawing

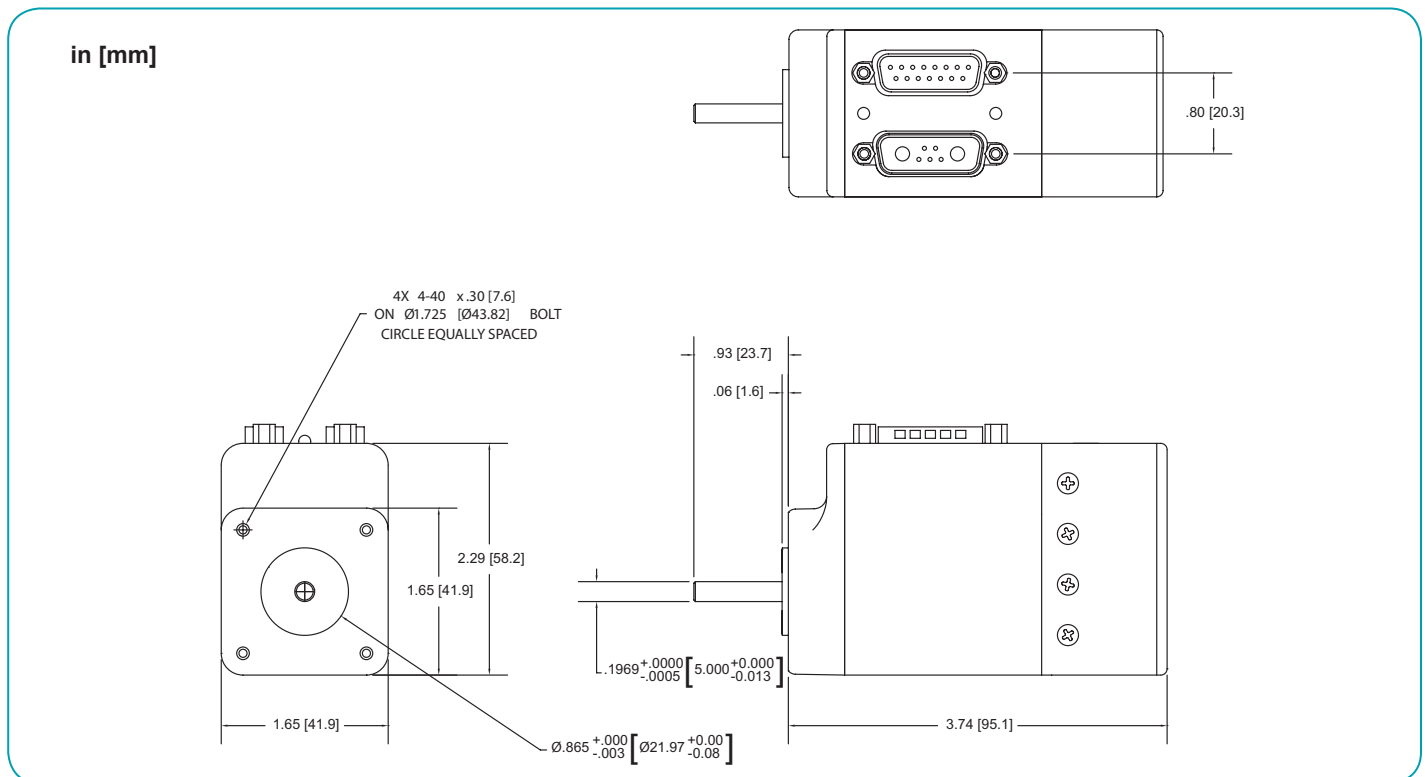

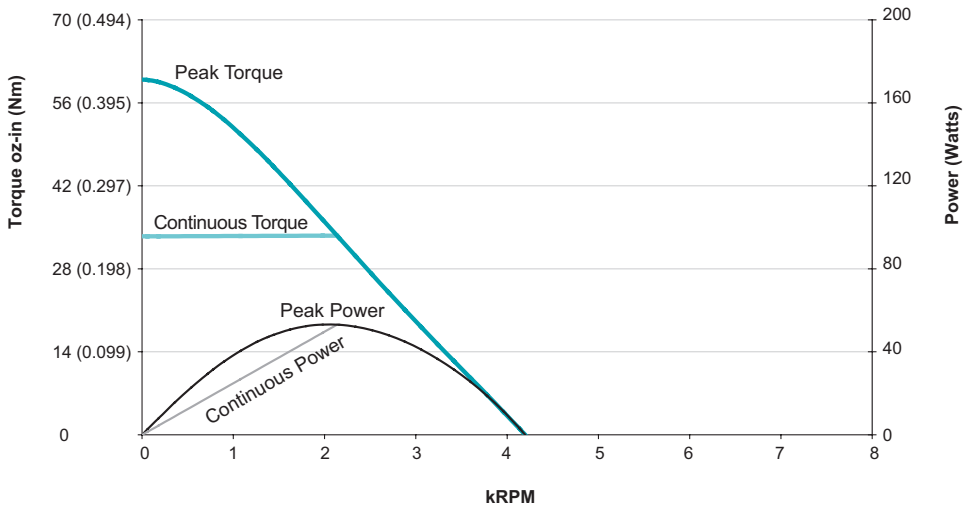
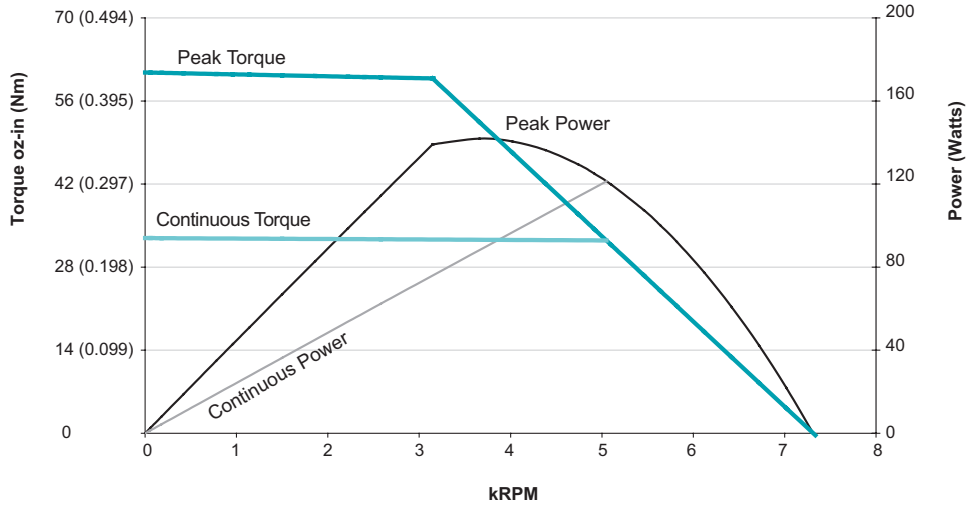
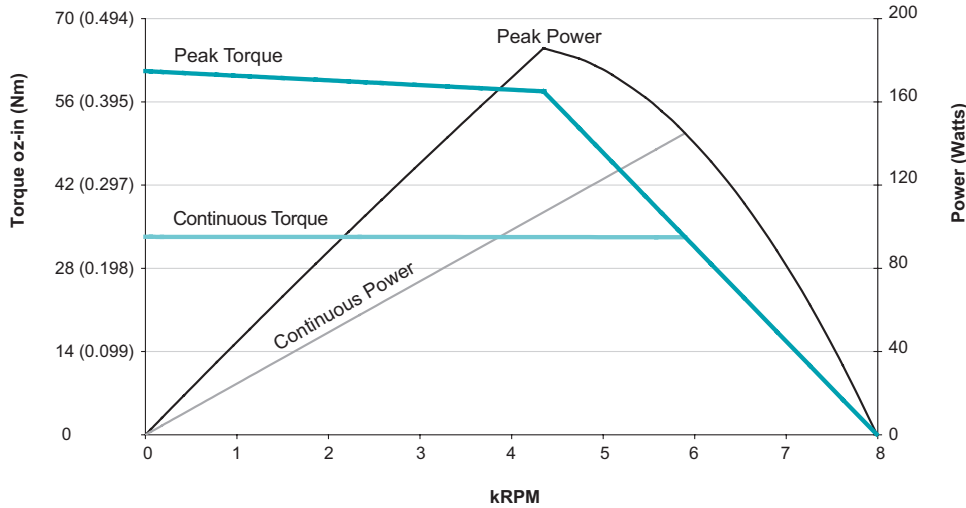

All torque curves based on 25°C ambient. Motors were operated using MDT (Trapezoidal Drive Mode) Commutation. For ambient temperatures above 25°C, Continuous Torque must be linearly derated to 0% at 85°C.

SM23165D		
Continuous Torque	2.50	in-lb
	40	oz-in
	0.28	N-m
Peak Torque	4.00	in-lb
	64	oz-in
	0.45	N-m
Nominal Continuous Power	181	Watt
No Load Speed	10,400	RPM
Max. Continuous Current* @ 6500 RPM	4.70	Amps
Peak Power @ 6100 RPM	183	Watts
Voltage Constant	4.45	V/kRPM
Inductance	0.829	mH
Encoder Resolution	4,000	Counts/Rev
Rotor Inertia	0.00099	oz-in-sec <sup>2</sup>
	0.6991	10 <sup>-5</sup> Kg-m <sup>2</sup>
Weight	1.0	lb
	0.45	kg
Shaft Diameter	0.250	in
	6.35	mm
Shaft, Radial Load	7	lb
	3.18	kg
Shaft, Axial Thrust Load	3	lb
	1.36	kg
DeviceNet Available	Yes	
PROFIBUS Available	Yes	
CANopen Available	Yes	

\*Default voltage is 48V. See graphs for additional voltages.



Operating temperature range: 0°C–85°C

Storage temperature range: -10°C–85°C, noncondensing

**NOTE: Motor specifications are subject to changes without notice. Consult website and factory for latest data.**



## Moog Animatics SmartMotor™ SM23165D (No Options) CAD Drawing

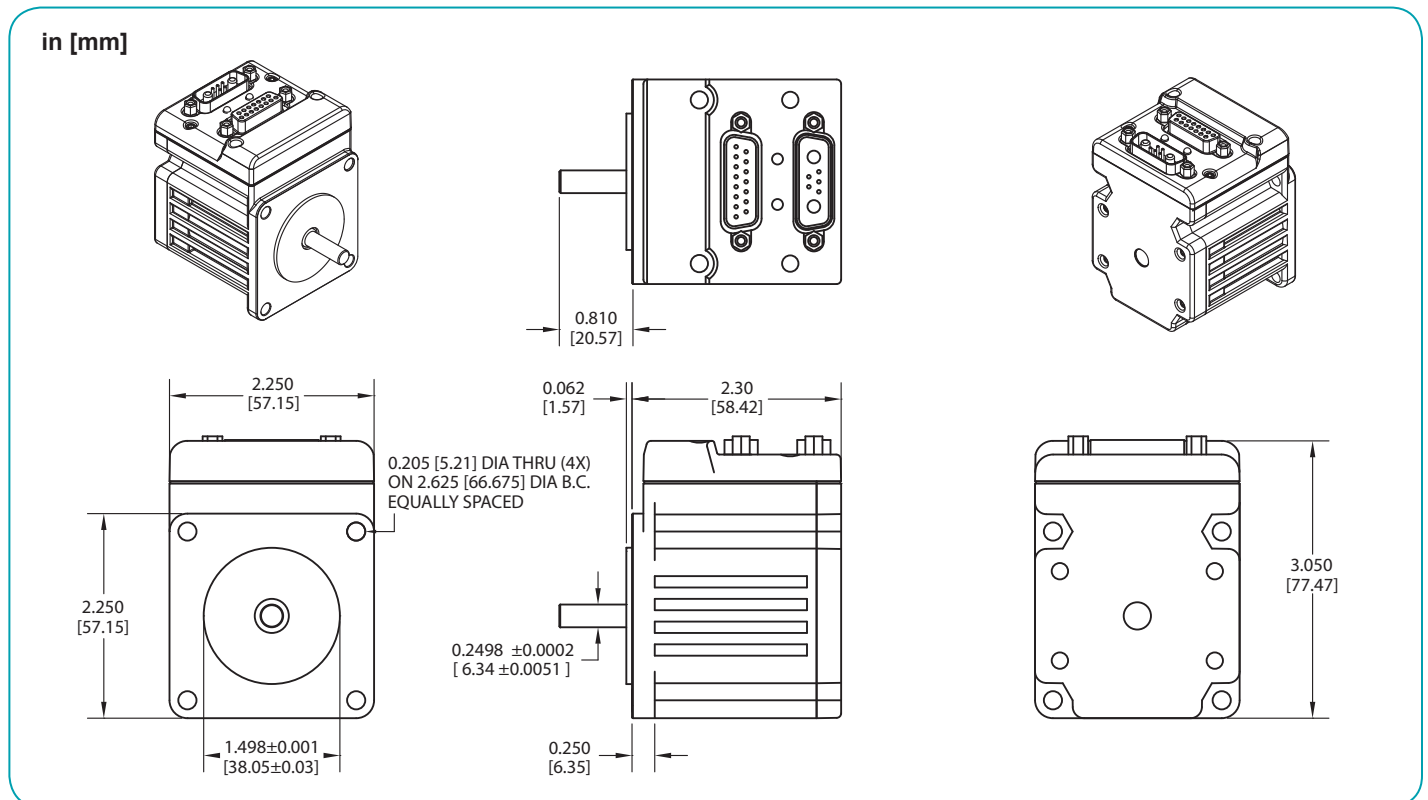

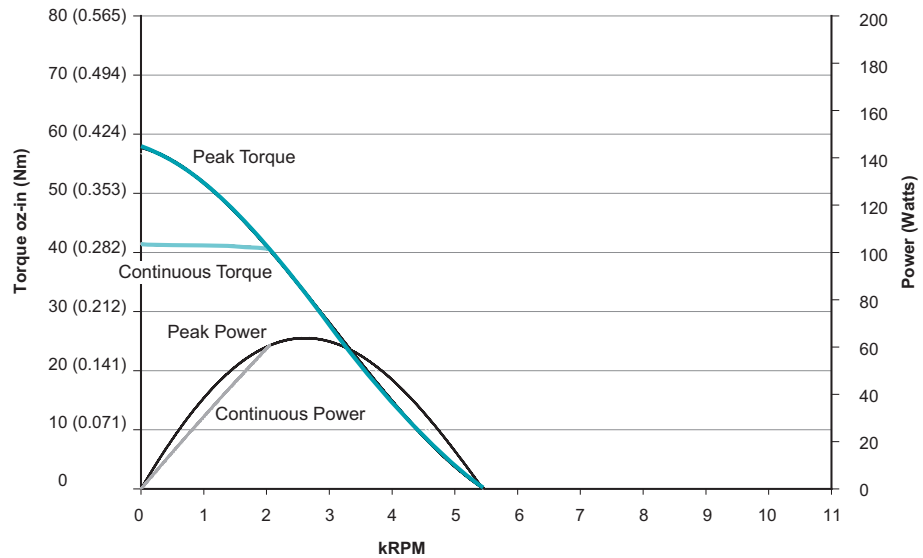
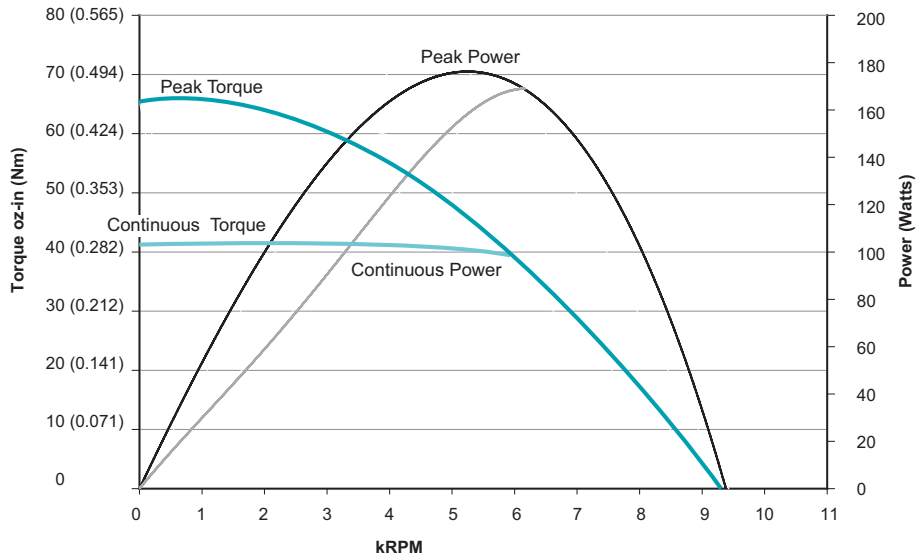
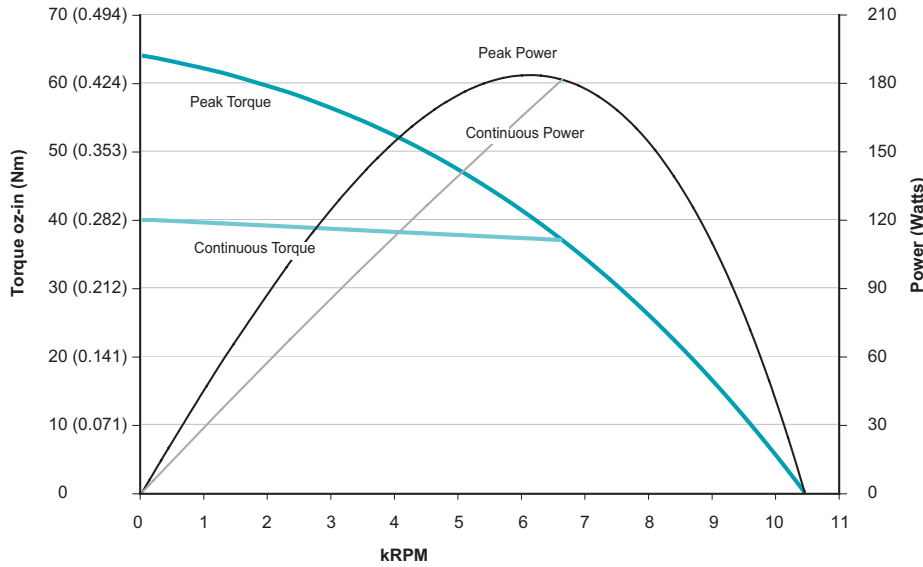

All torque curves based on 25°C ambient. Motors were operated using MDT (Trapezoidal Drive Mode) Commutation. For ambient temperatures above 25°C, Continuous Torque must be linearly derated to 0% at 85°C.

SM23165DT		
Continuous Torque	4.61	in-lb
	74	oz-in
	0.52	N-m
Peak Torque	7.40	in-lb
	118	oz-in
	0.84	N-m
Nominal Continuous Power	204	Watt
No Load Speed	5,200	RPM
Max. Continuous Current* @ 3800 RPM	5.074	Amps
Peak Power @ 3400 RPM	210	Watts
Voltage Constant	9.08	V/kRPM
Inductance	1.31	mH
Encoder Resolution	4,000	Counts/Rev
Rotor Inertia	0.001	oz-in-sec <sup>2</sup>
	0.706	10 <sup>-5</sup> Kg-m <sup>2</sup>
Weight	1.3	lb
	0.59	kg
Shaft Diameter	0.250	in
	6.35	mm
Shaft, Radial Load	7	lb
	3.18	kg
Shaft, Axial Thrust Load	3	lb
	1.36	kg
DeviceNet Available	Yes	
PROFIBUS Available	Yes	
CANopen Available	Yes	

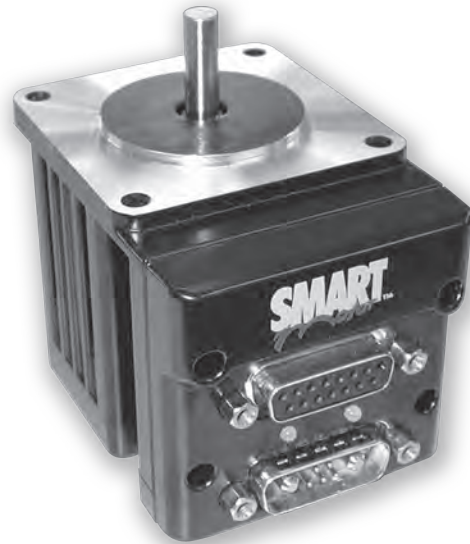

Operating temperature range: 0°C–85°C

Storage temperature range: -10°C–85°C, noncondensing

**NOTE: Motor specifications are subject to changes without notice. Consult website and factory for latest data.**



\*Default voltage is 48V. See graphs for additional voltages.

## Moog Animatics SmartMotor™ SM23165DT (No Options) CAD Drawing

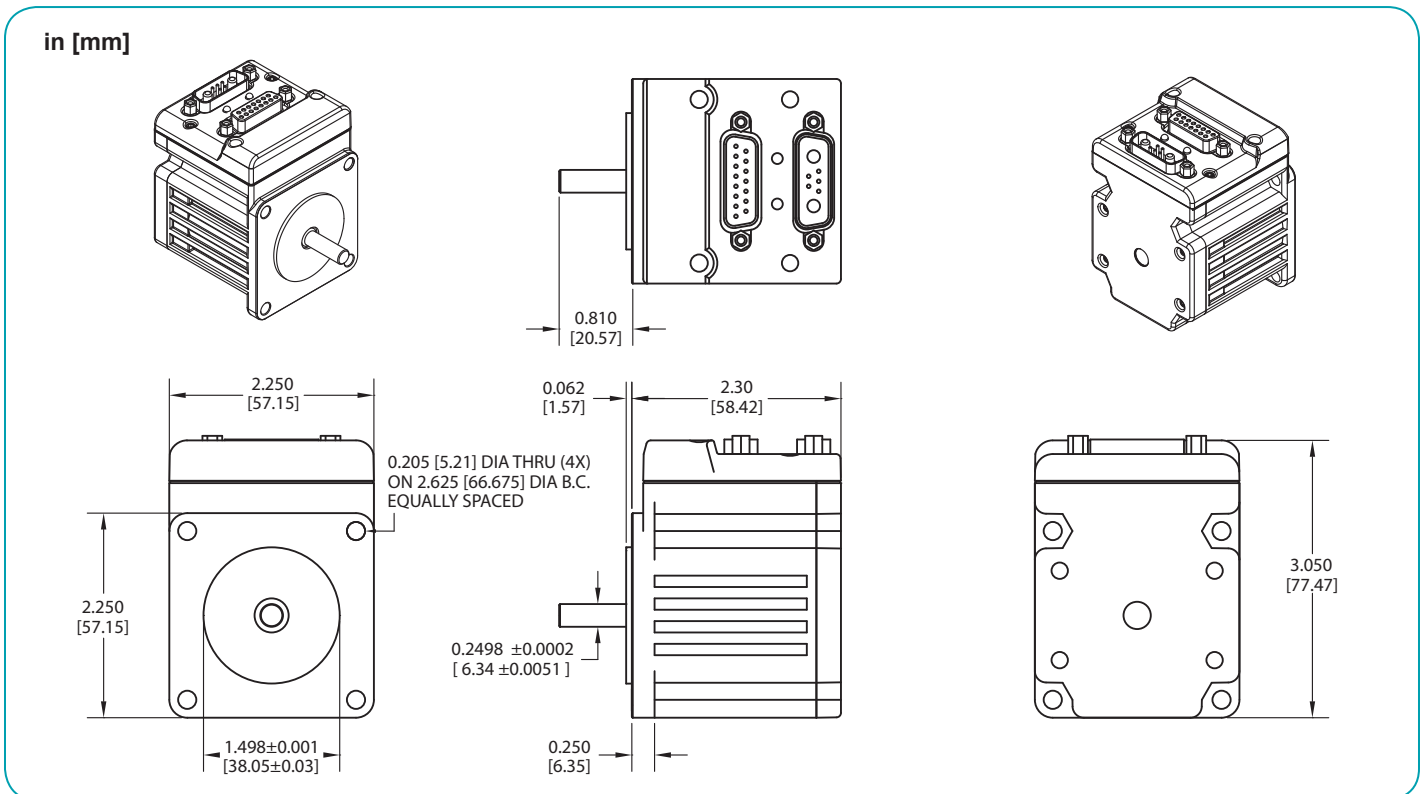

OVERVIEW  
SOFTWARE  
D-STYLE MOTORS  
D-STYLE CONNECTIVITY  
PERIPHERALS  
M-STYLE MOTORS  
M-STYLE CONNECTIVITY  
LINEAR SYSTEMS  
POWER SUPPLIES & SHUNTS  
GEAR HEADS  
APPENDIX

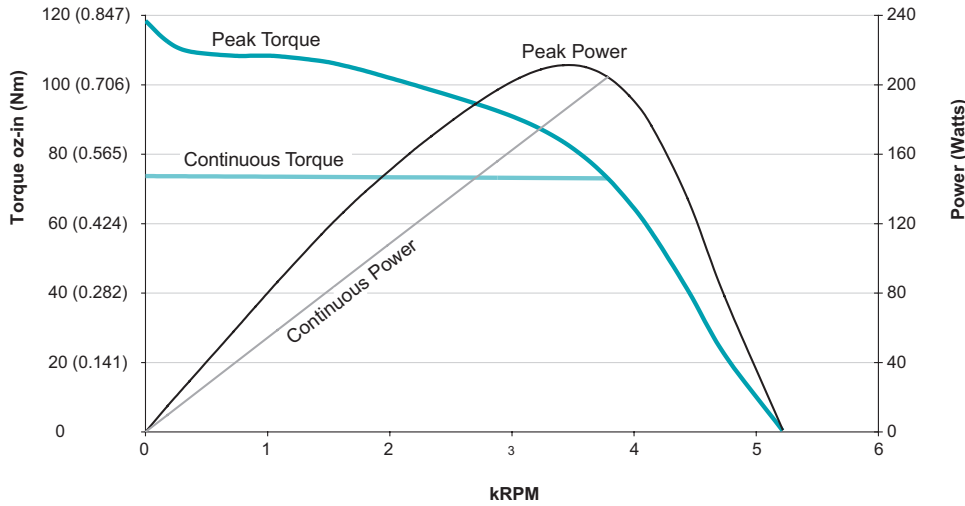

**SM23165DT**  
**at 48 VDC**  
**at rise to 85°C**

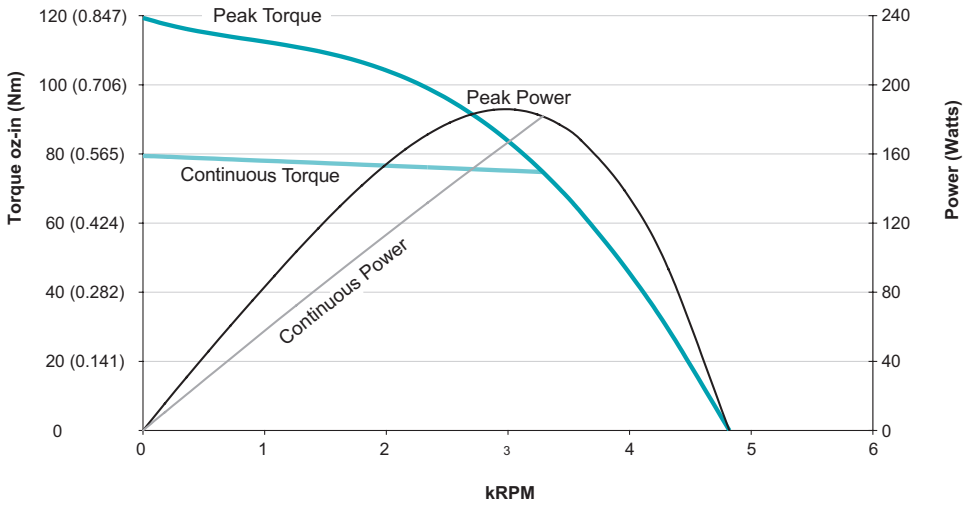

**SM23165DT**  
**at 42 VDC**  
**at rise to 85°C**

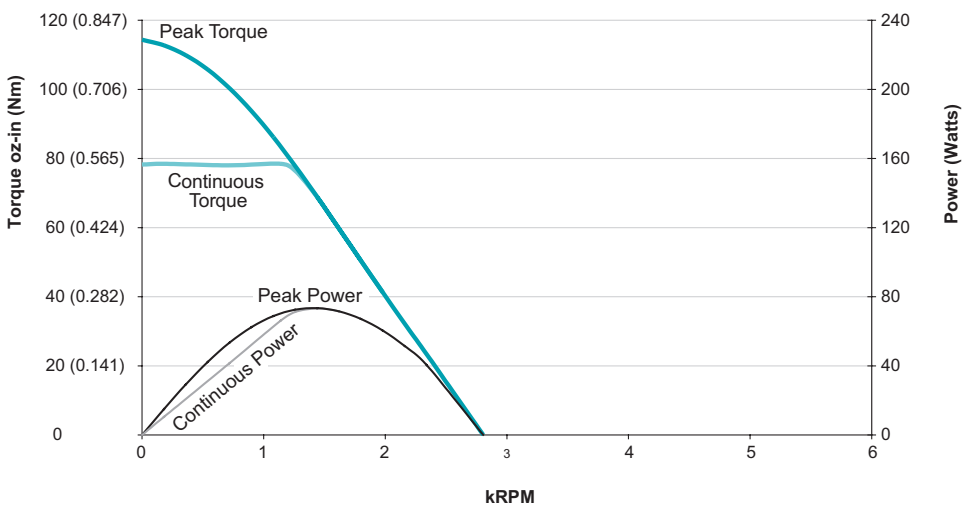

**SM23165DT**  
**at 24 VDC**  
**at rise to 85°C**

All torque curves based on 25°C ambient.  
Motors were operated using MDT (Trapezoidal Drive Mode) Commutation.  
For ambient temperatures above 25°C, Continuous Torque must be linearly derated to 0% at 85°C.

SM23375D	
Continuous Torque	2.86 in-lb
	46 oz-in
	0.32 N-m
Peak Torque	5.00 in-lb
	80 oz-in
	0.57 N-m
Nominal Continuous Power	191 Watt
No Load Speed	8,000 RPM
Max. Continuous Current* @ 6000 RPM	5.072 Amps
Peak Power @ 4750 RPM	220 Watts
Voltage Constant	5.62 V/kRPM
Inductance	0.770 mH
Encoder Resolution	4,000 Counts/Rev
Rotor Inertia	0.0019 oz-in-sec <sup>2</sup>
	1.342 10 <sup>-5</sup> Kg-m <sup>2</sup>
Weight	2.1 lb
	0.95 kg
Shaft Diameter	0.250 in
	6.35 mm
Shaft, Radial Load	7 lb
	3.18 kg
Shaft, Axial Thrust Load	3 lb
	1.36 kg
DeviceNet Available	Yes
PROFIBUS Available	
CANopen Available	Yes

\*Default voltage is 48V. See graphs for additional voltages.



Operating temperature range: 0°C–85°C  
Storage temperature range: -10°C–85°C, noncondensing

**NOTE:** Motor specifications are subject to changes without notice. Consult website and factory for latest data.



## Moog Animatics SmartMotor SM23375D (No Options) CAD Drawing

in [mm]

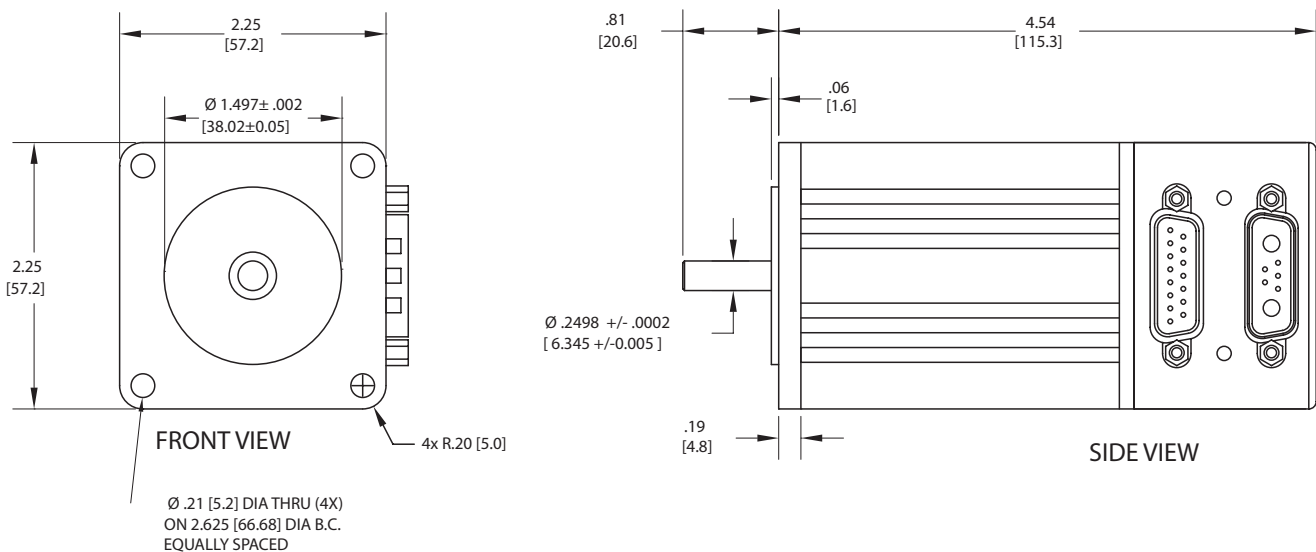

OVERVIEW  
SOFTWARE  
D-STYLE MOTORS  
D-STYLE CONNECTIVITY  
PERIPHERALS  
M-STYLE MOTORS  
M-STYLE CONNECTIVITY  
LINEAR SYSTEMS  
POWER SUPPLIES & SHUNTS  
GEAR HEADS  
APPENDIX

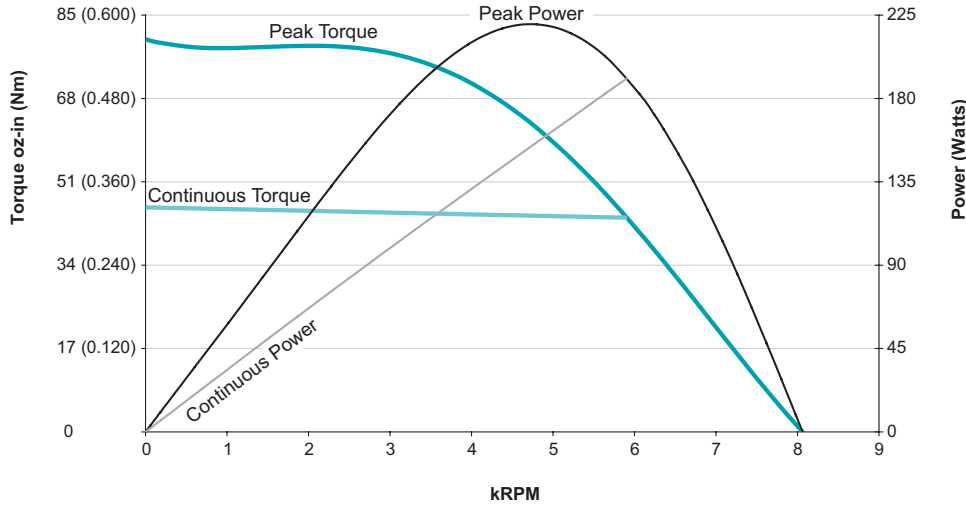

**SM23375D  
at 48 VDC  
at rise to 85°C**

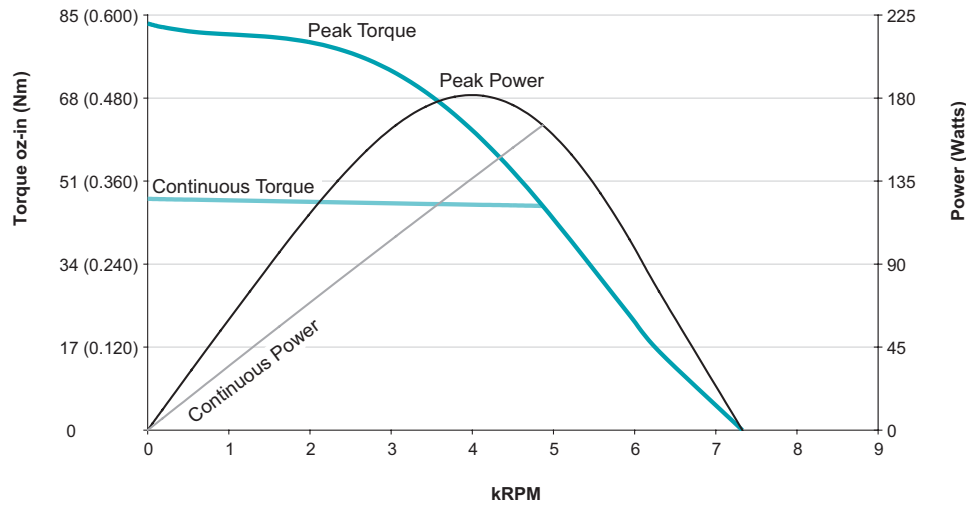

**SM23375D  
at 42 VDC  
at rise to 85°C**

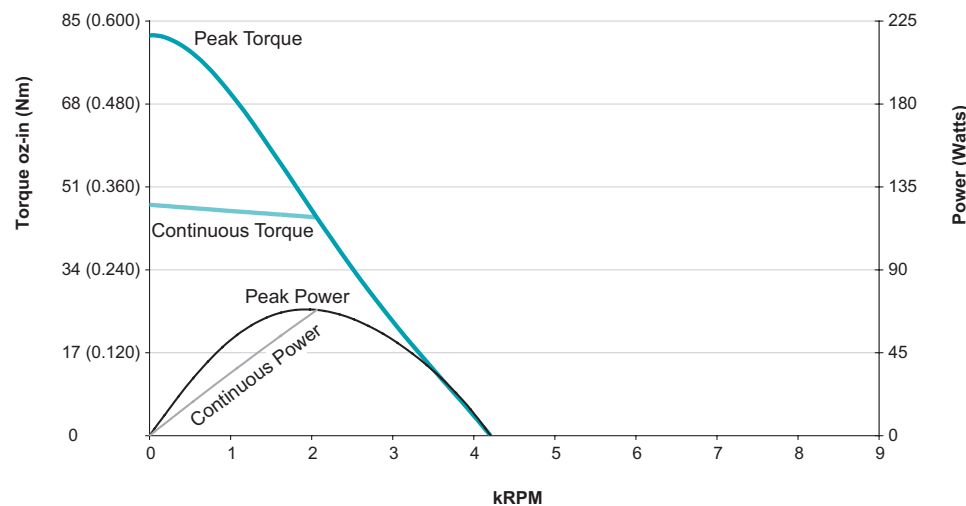

**SM23375D  
at 24 VDC  
at rise to 85°C**

All torque curves based on 25°C ambient.  
Motors were operated using MDT (Trapezoidal Drive Mode) Commutation.  
For ambient temperatures above 25°C, Continuous Torque must be linearly derated to 0% at 85°C.



SM23375DT	
Continuous Torque	5.18 in-lb
	83 oz-in
	0.59 N-m
Peak Torque	9.80 in-lb
	157 oz-in
	1.11 N-m
Nominal Continuous Power	186 Watt
No Load Speed	4,000 RPM
Max. Continuous Current* @ 3250 RPM	4.52 Amps
Peak Power @ 2450 RPM	235 Watts
Voltage Constant	10.95 V/kRPM
Inductance	0.906 mH
Encoder Resolution	4,000 Counts/Rev
Rotor Inertia	0.0019 oz-in-sec <sup>2</sup>
	1.342 10 <sup>-5</sup> Kg-m <sup>2</sup>
Weight	2.2 lb
	0.98 kg
Shaft Diameter	0.250 in
	6.35 mm
Shaft, Radial Load	7 lb
	3.18 kg
Shaft, Axial Thrust Load	3 lb
	1.36 kg
DeviceNet Available	Yes
PROFIBUS Available	
CANopen Available	Yes

\*Default voltage is 48V. See graphs for additional voltages.



Operating temperature range: 0°C–85°C  
Storage temperature range: -10°C–85°C, noncondensing

**NOTE:** Motor specifications are subject to changes without notice. Consult website and factory for latest data.



## Moog Animatics SmartMotor SM23375DT (No Options) CAD Drawing

in [mm]

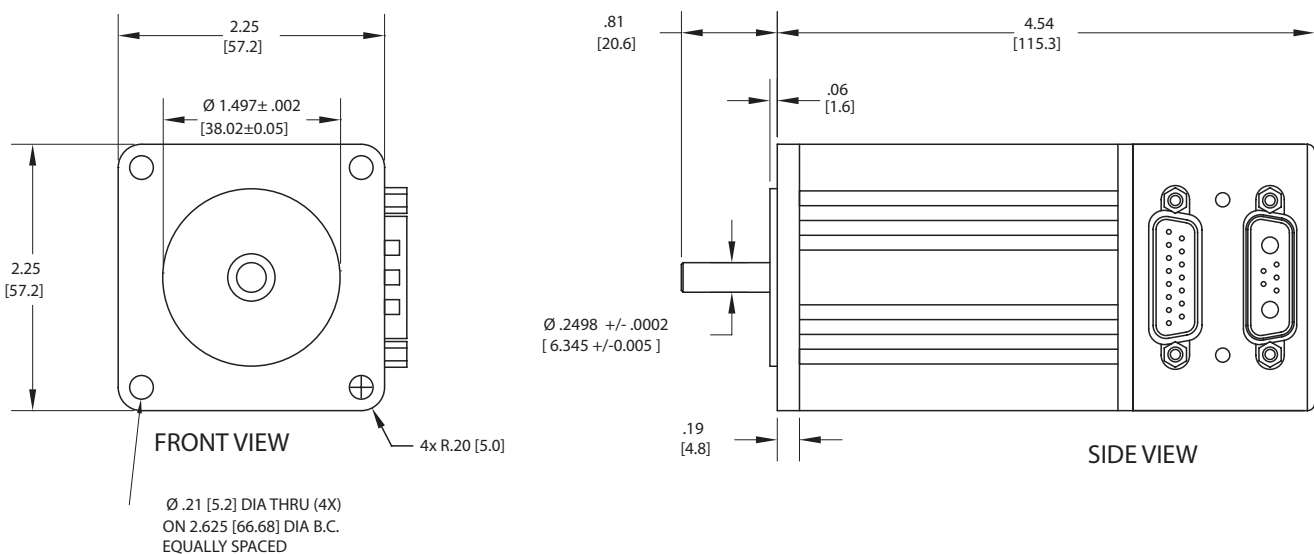

APPENDIX GEAR HEADS POWER SUPPLIES & SHUNTS LINEAR SYSTEMS M-STYLE CONNECTIVITY M-STYLE MOTORS PERIPHERALS D-STYLE CONNECTIVITY D-STYLE MOTORS SOFTWARE OVERVIEW

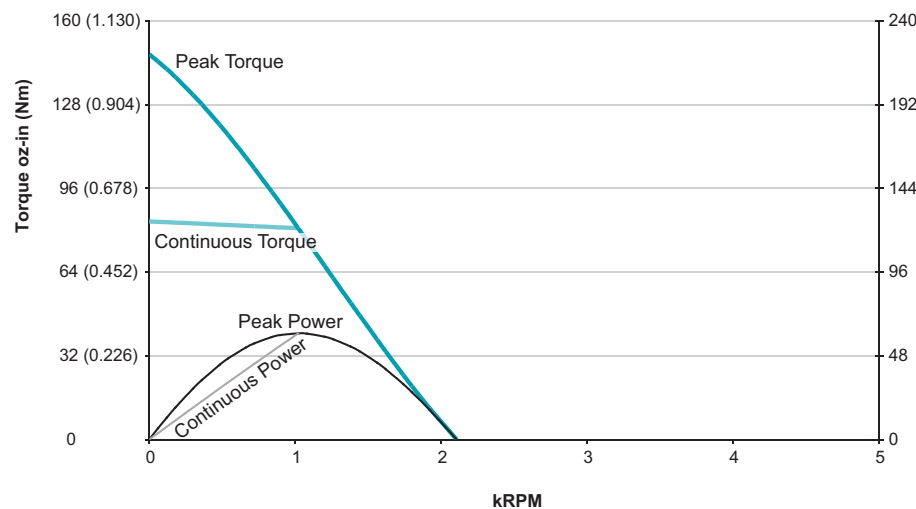
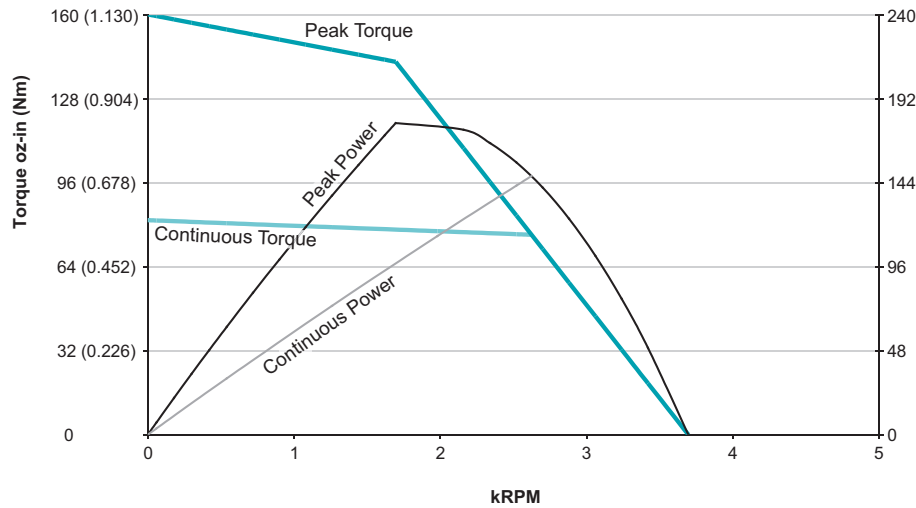
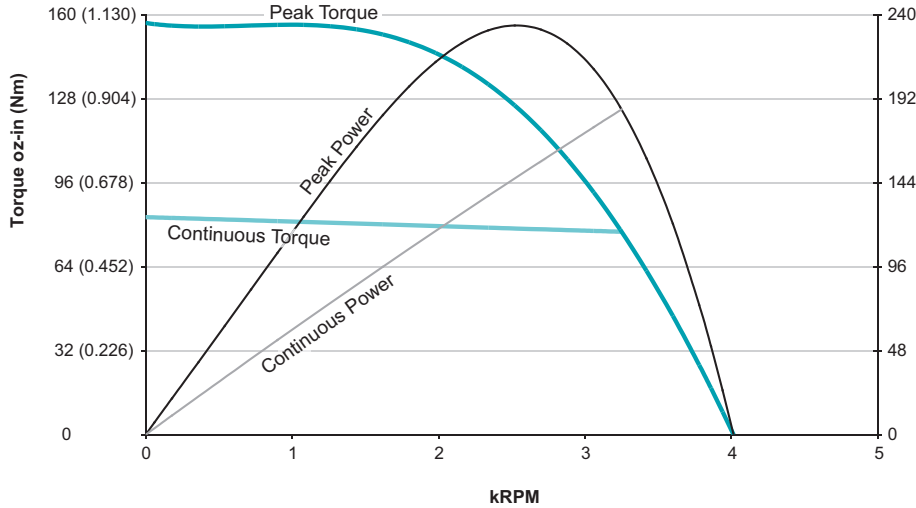

All torque curves based on 25°C ambient. Motors were operated using MDT (Trapezoidal Drive Mode) Commutation. For ambient temperatures above 25°C, Continuous Torque must be linearly derated to 0% at 85°C.

SM23205D		
Continuous Torque	2.96	in-lb
	47	oz-in
	0.33	N-m
Peak Torque	5.03	in-lb
	80	oz-in
	0.57	N-m
Nominal Continuous Power	226	Watt
No Load Speed	8,100	RPM
Max. Continuous Current* @ 6900 RPM	6.02	Amps
Peak Power @ 5995 RPM	335	Watts
Voltage Constant	6.137	V/kRPM
Inductance	0.40	mH
Encoder Resolution	4,000	Counts/Rev
Rotor Inertia	0.00224	oz-in-sec <sup>2</sup>
	1.582	10 <sup>-5</sup> Kg-m <sup>2</sup>
Weight	1.7	lb
	0.79	kg
Shaft Diameter	0.250	in
	6.35	mm
Shaft, Radial Load	7	lb
	3.18	kg
Shaft, Axial Thrust Load	3	lb
	1.36	kg
DeviceNet Available	Yes	
PROFIBUS Available		
CANopen Available	Yes	

\*Default voltage is 48V. See graphs for additional voltages.



Operating temperature range: 0°C–85°C  
Storage temperature range: -10°C–85°C, noncondensing

**NOTE: Motor specifications are subject to changes without notice. Consult website and factory for latest data.**



## Moog Animatics SmartMotor SM23205D (No Options) CAD Drawing

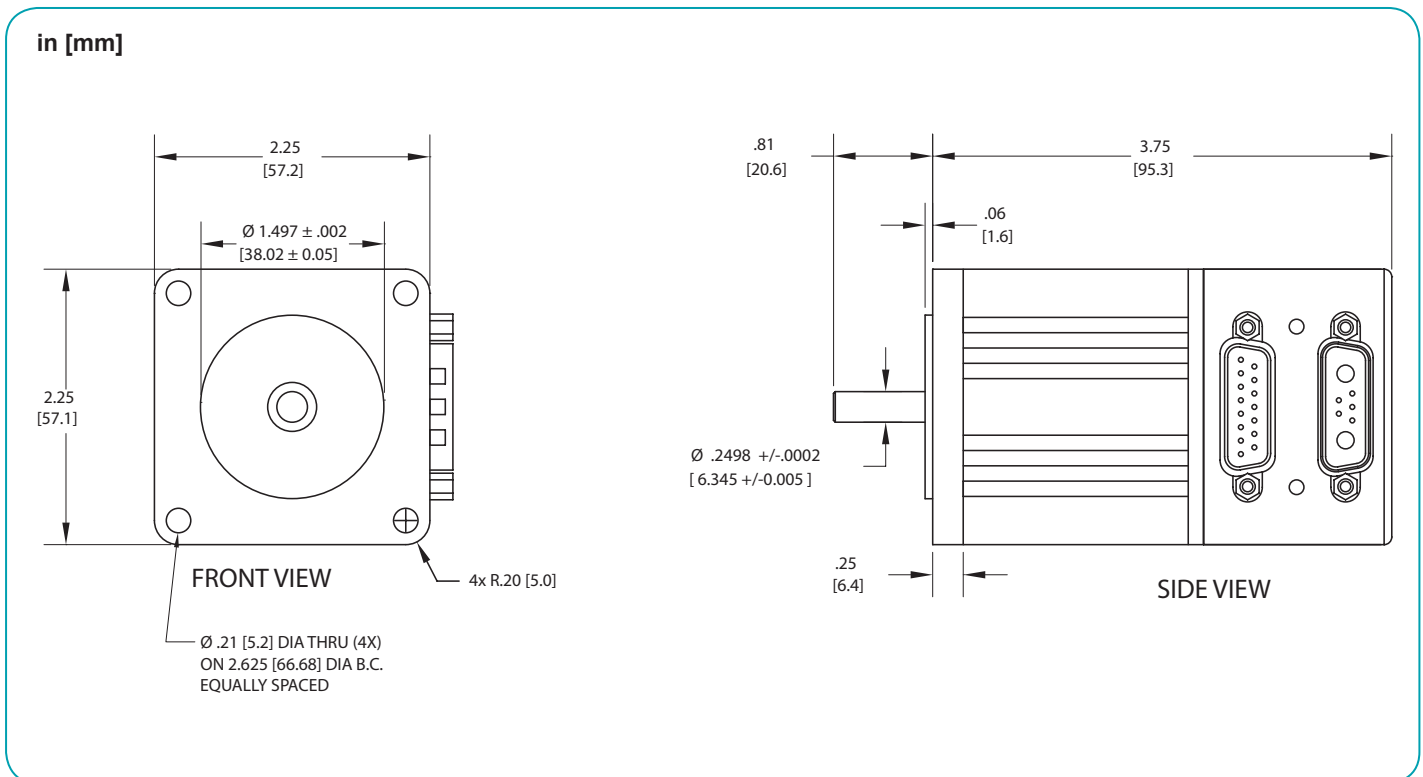

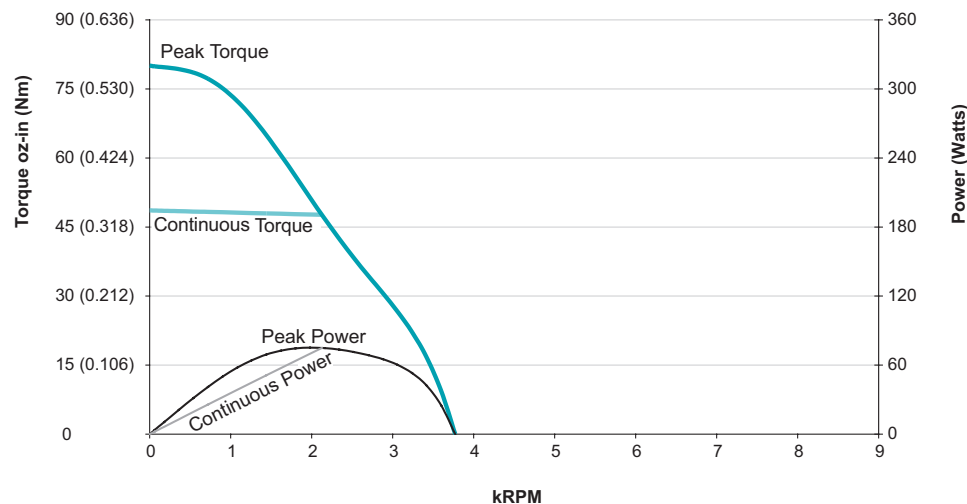
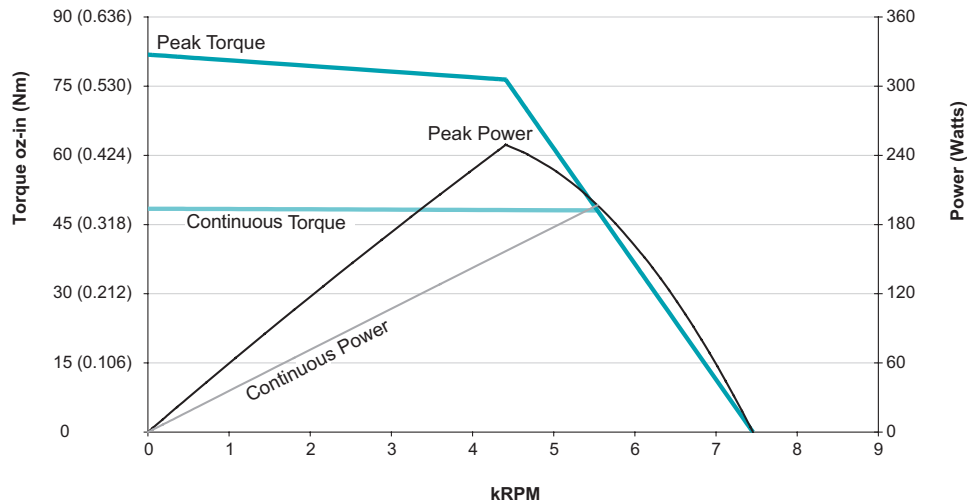
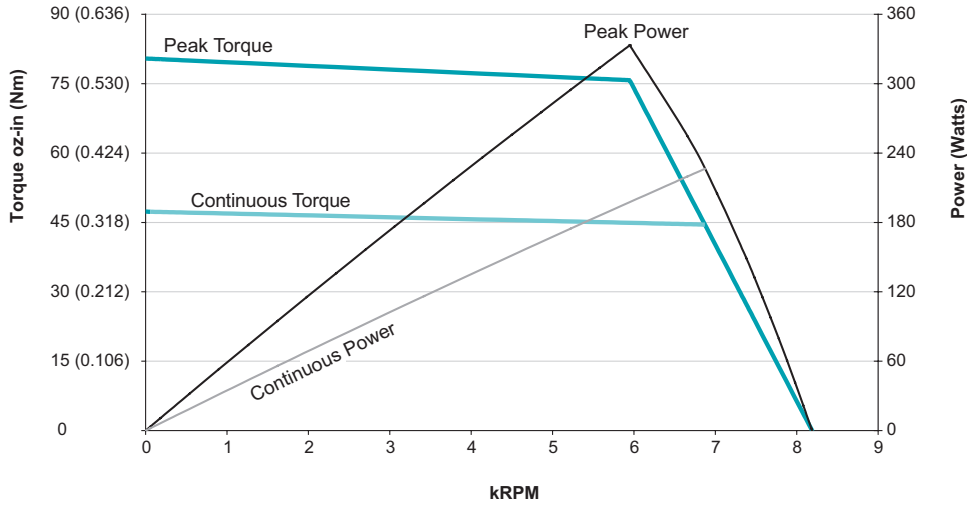

All torque curves based on 25°C ambient. Motors were operated using MDT (Trapezoidal Drive Mode) Commutation. For ambient temperatures above 25°C, Continuous Torque must be linearly derated to 0% at 85°C.

SM23305D		
Continuous Torque	3.98	in-lb
	64	oz-in
	0.45	N-m
Peak Torque	6.86	in-lb
	110	oz-in
	0.77	N-m
Nominal Continuous Power	220	Watt
No Load Speed	5,600	RPM
Max. Continuous Current* @ 4750 RPM	5.57	Amps
Peak Power @ 4100 RPM	325	Watts
Voltage Constant	8.873	V/kRPM
Inductance	0.61	mH
Encoder Resolution	4,000	Counts/Rev
Rotor Inertia	0.00332	oz-in-sec <sup>2</sup>
	2.344	10 <sup>-5</sup> Kg-m <sup>2</sup>
Weight	2.3	lb
	1.03	kg
Shaft Diameter	0.250	in
	6.35	mm
Shaft, Radial Load	7	lb
	3.18	kg
Shaft, Axial Thrust Load	3	lb
	1.36	kg
DeviceNet Available	Yes	
PROFIBUS Available		
CANopen Available	Yes	

\*Default voltage is 48V. See graphs for additional voltages.



Operating temperature range: 0°C–85°C  
Storage temperature range: -10°C–85°C, noncondensing

**NOTE: Motor specifications are subject to changes without notice. Consult website and factory for latest data.**



## Moog Animatics SmartMotor SM23305D (No Options) CAD Drawing

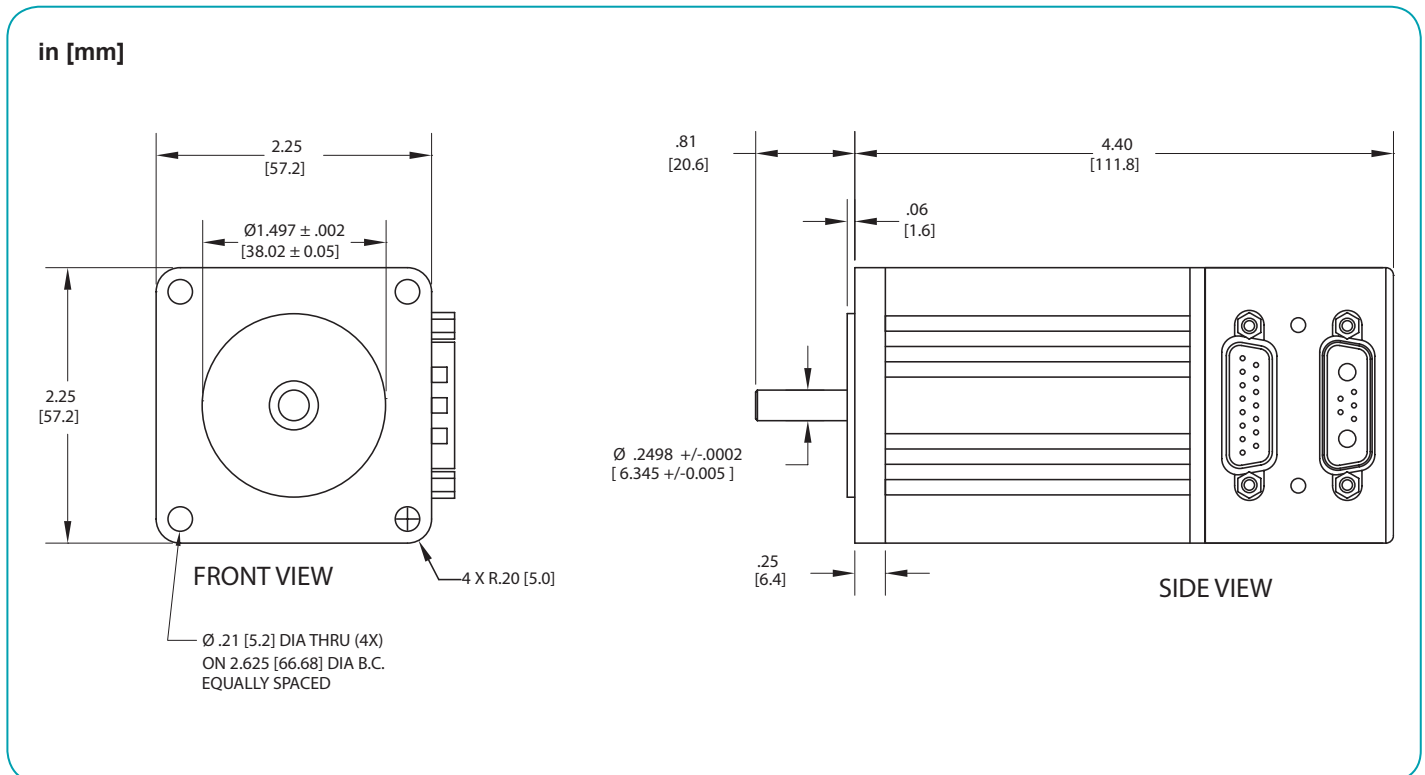

OVERVIEW  
SOFTWARE  
D-STYLE MOTORS  
D-STYLE CONNECTIVITY  
PERIPHERALS  
M-STYLE MOTORS  
M-STYLE CONNECTIVITY  
LINEAR SYSTEMS  
POWER SUPPLIES & SHUNTS  
GEAR HEADS  
APPENDIX

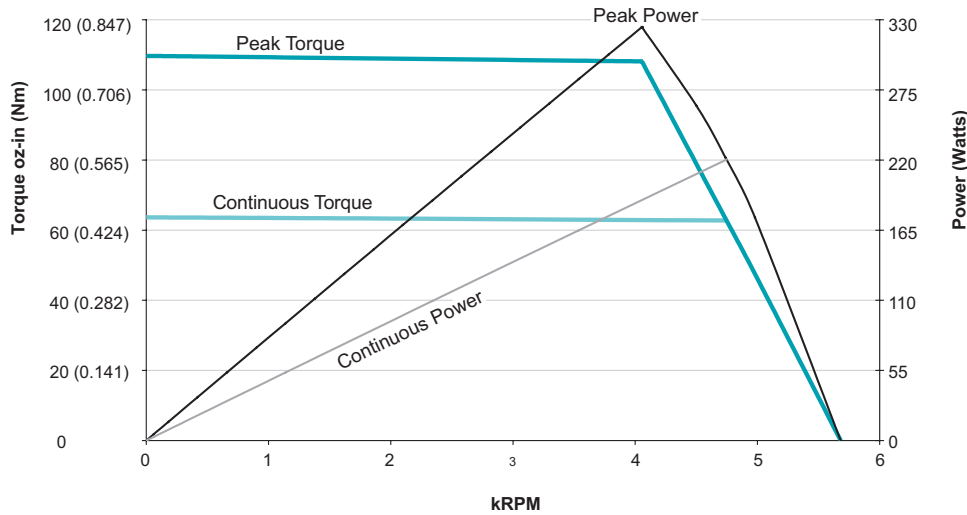

**SM23305D**  
**at 48 VDC**  
**at rise to 85°C**

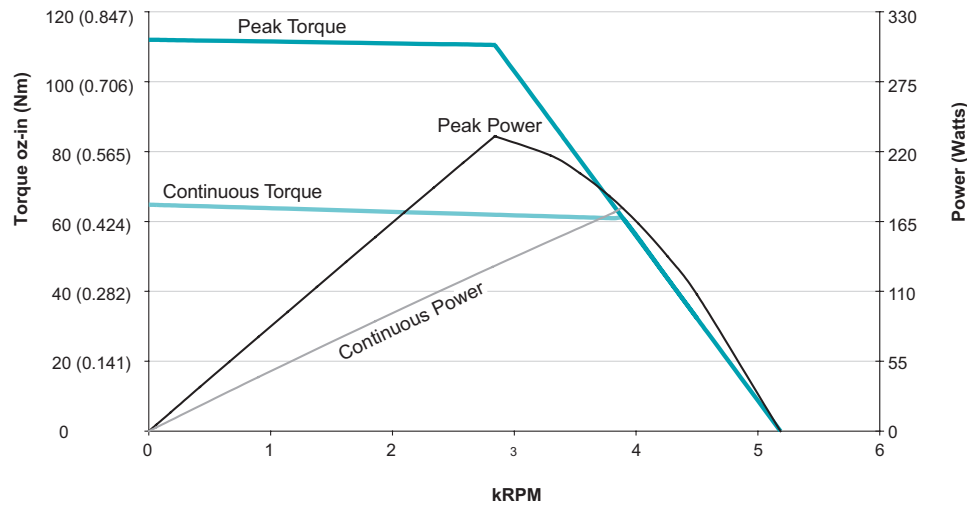

**SM23305D**  
**at 42 VDC**  
**at rise to 85°C**

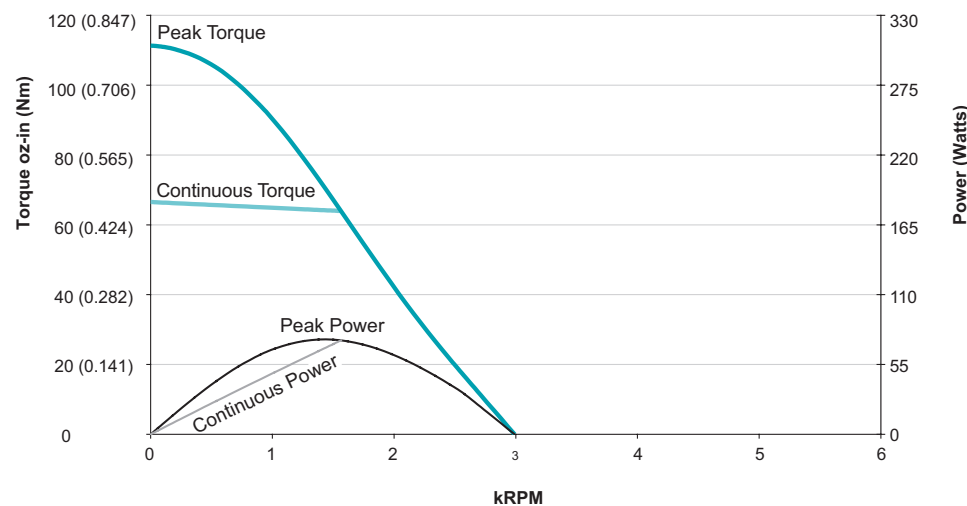

**SM23305D**  
**at 24 VDC**  
**at rise to 85°C**

All torque curves based on 25°C ambient.  
Motors were operated using MDT (Trapezoidal Drive Mode) Commutation.  
For ambient temperatures above 25°C, Continuous Torque must be linearly derated to 0% at 85°C.

SM23405D		
Continuous Torque	4.88	in-lb
	78	oz-in
	0.55	N-m
Peak Torque	8.04	in-lb
	129	oz-in
	0.91	N-m
Nominal Continuous Power	253	Watt
No Load Speed	5,300	RPM
Max. Continuous Current* @ 4500 RPM	6.76	Amps
Peak Power @ 4000 RPM	345	Watts
Voltage Constant	9.612	V/kRPM
Inductance	0.49	mH
Encoder Resolution	4,000	Counts/Rev
Rotor Inertia	0.00439	oz-in-sec <sup>2</sup>
	3.100	10 <sup>-5</sup> Kg-m <sup>2</sup>
Weight	2.8	lb
	1.27	kg
Shaft Diameter	0.250	in
	6.35	mm
Shaft, Radial Load	7	lb
	3.18	kg
Shaft, Axial Thrust Load	3	lb
	1.36	kg
DeviceNet Available	Yes	
PROFIBUS Available		
CANopen Available	Yes	

\*Default voltage is 48V. See graphs for additional voltages.



Operating temperature range: 0°C–85°C  
Storage temperature range: -10°C–85°C, noncondensing

**NOTE: Motor specifications are subject to changes without notice. Consult website and factory for latest data.**



## Moog Animatics SmartMotor SM23405D (No Options) CAD Drawing

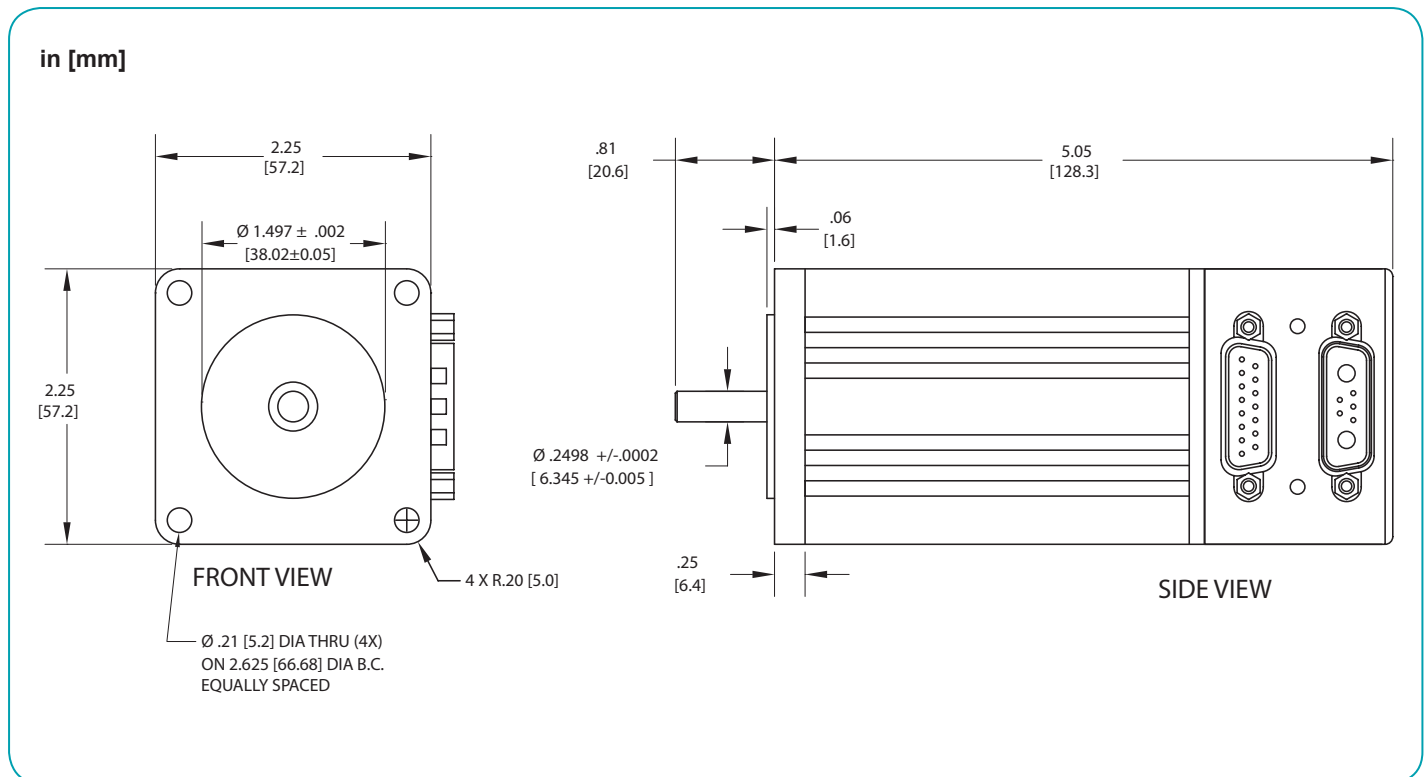

- OVERVIEW
- SOFTWARE
- D-STYLE MOTORS
- D-STYLE CONNECTIVITY
- PERIPHERALS
- M-STYLE MOTORS
- M-STYLE CONNECTIVITY
- LINEAR SYSTEMS
- POWER SUPPLIES & SHUNTS
- GEAR HEADS
- APPENDIX

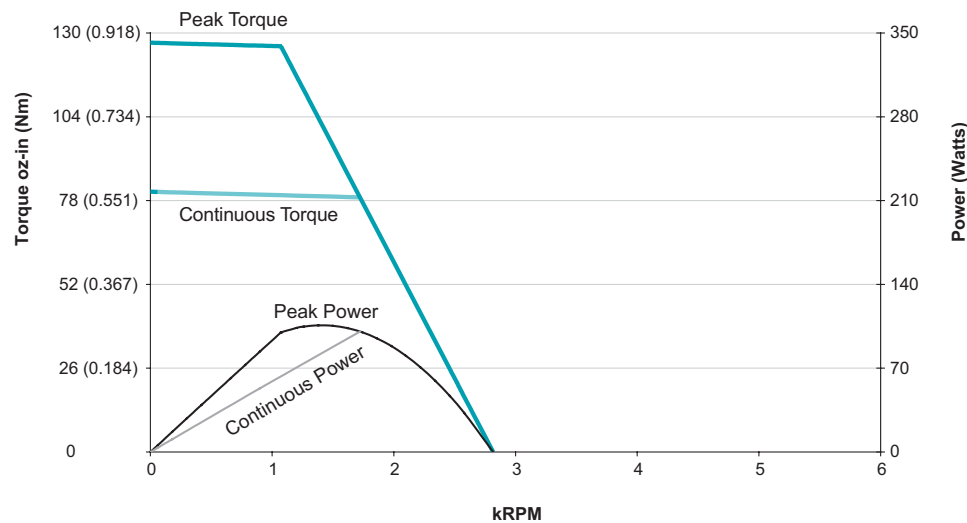
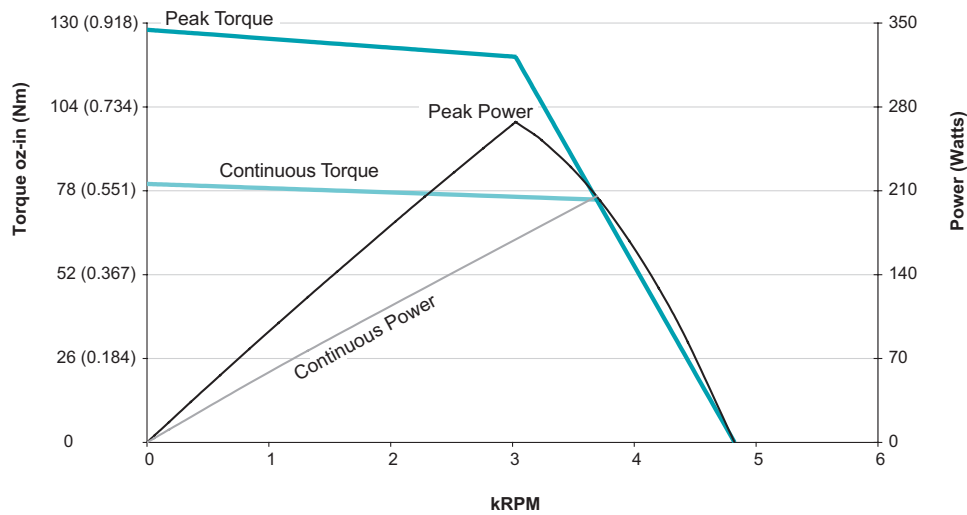
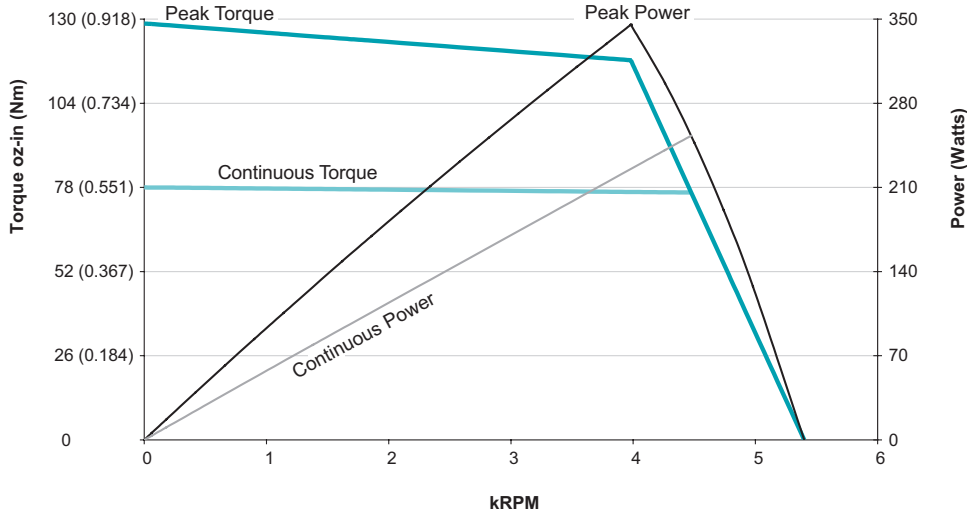

All torque curves based on 25°C ambient.  
 Motors were operated using MDT (Trapezoidal Drive Mode) Commutation.  
 For ambient temperatures above 25°C, Continuous Torque must be linearly derated to 0% at 85°C.



SM34165D		
Continuous Torque	9.67	in-lb
	155	oz-in
	1.09	N-m
Peak Torque	14.12	in-lb
	226	oz-in
	1.60	N-m
Nominal Continuous Power	235	Watt
No Load Speed	3,100	RPM
Max. Continuous Current* @ 2400 RPM	6.02	Amps
Peak Power @ 1900 RPM	265	Watts
Voltage Constant	14.98	V/kRPM
Inductance	1.72	mH
Encoder Resolution	8,000	Counts/Rev
Rotor Inertia	0.014	oz-in-sec <sup>2</sup>
	9.890	10 <sup>-5</sup> Kg-m <sup>2</sup>
Weight	5.0	lb
	2.27	kg
Shaft Diameter	0.375	in
	9.53	mm
Shaft, Radial Load	15	lb
	6.80	kg
Shaft, Axial Thrust Load	3	lb
	1.36	kg
DeviceNet Available	Yes	
PROFIBUS Available	Yes	
CANopen Available	Yes	

\*Default voltage is 48V. See graphs for additional voltages.



Operating temperature range: 0°C–85°C

Storage temperature range: -10°C–85°C, noncondensing

**NOTE: Motor specifications are subject to changes without notice. Consult website and factory for latest data.**



## Moog Animatics SmartMotor™ SM34165D (No Options) CAD Drawing

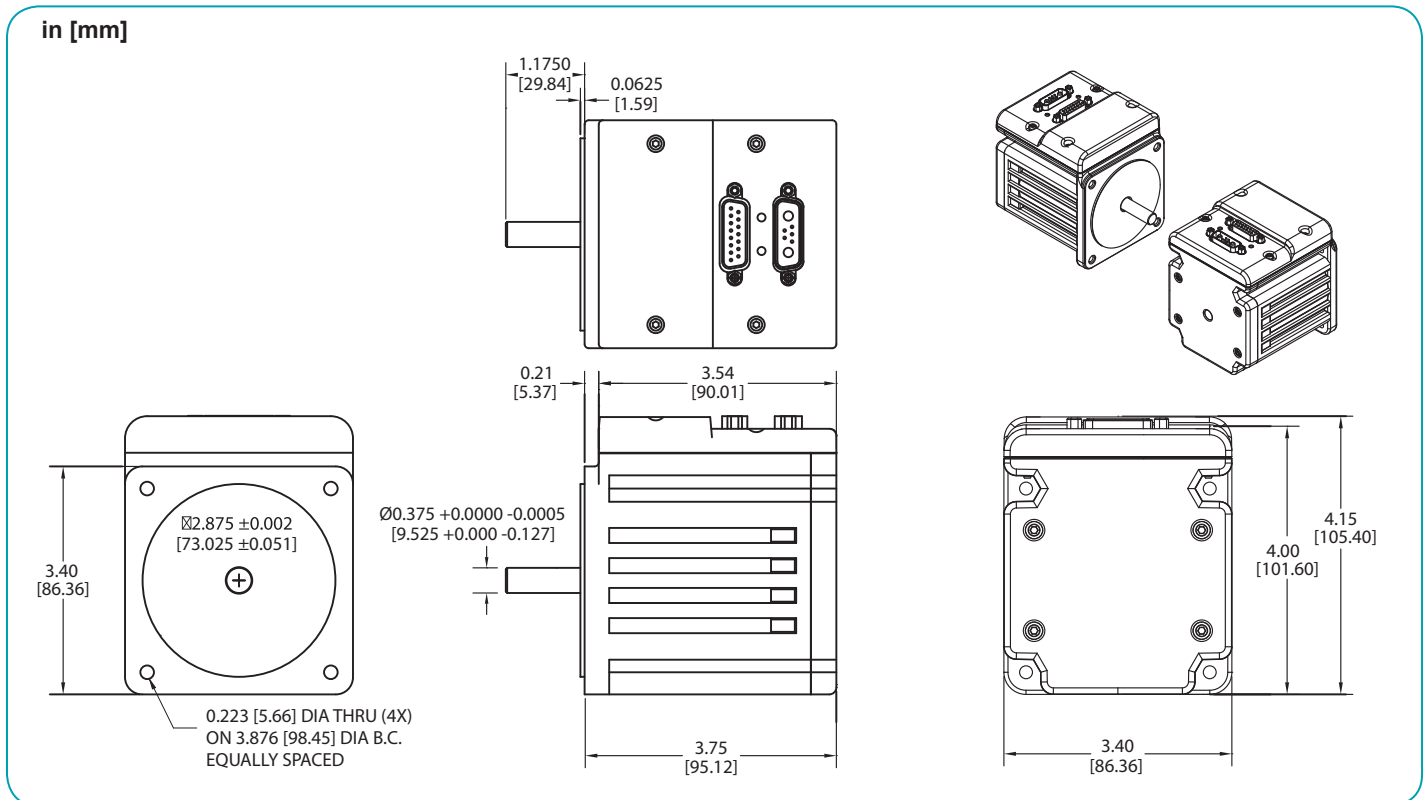

OVERVIEW  
SOFTWARE  
D-STYLE MOTORS  
D-STYLE CONNECTIVITY  
PERIPHERALS  
M-STYLE MOTORS  
M-STYLE CONNECTIVITY  
LINEAR SYSTEMS  
POWER SUPPLIES & SHUNTS  
GEAR HEADS  
APPENDIX

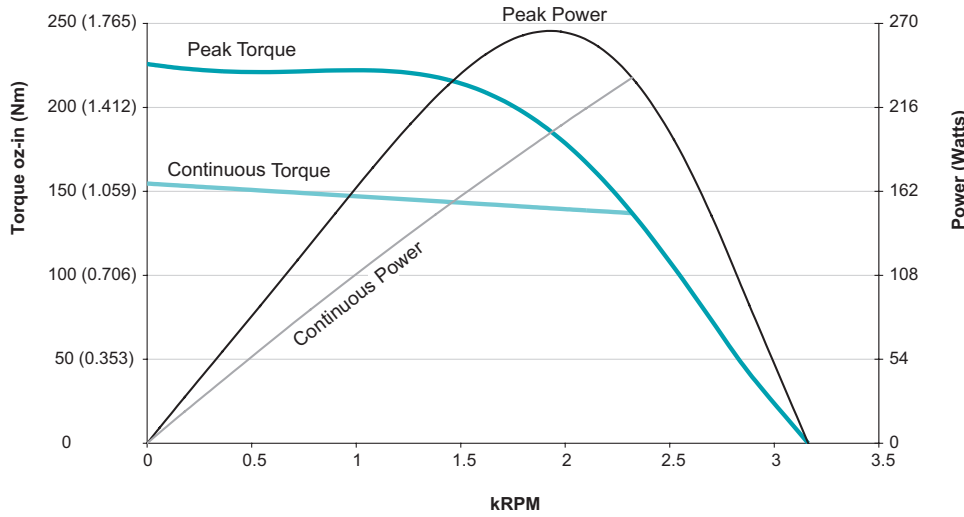

**SM34165D**  
**at 48 VDC**  
**at rise to 85°C**

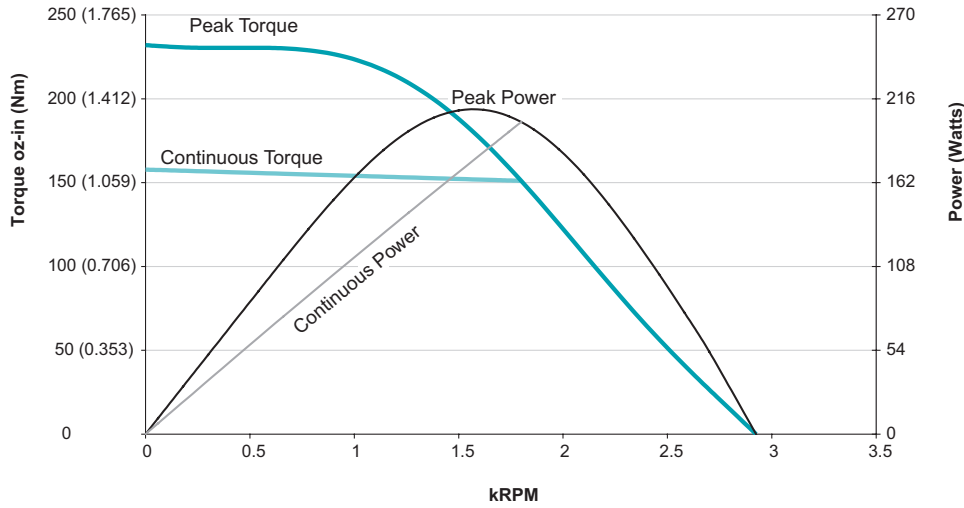

**SM34165D**  
**at 42 VDC**  
**at rise to 85°C**

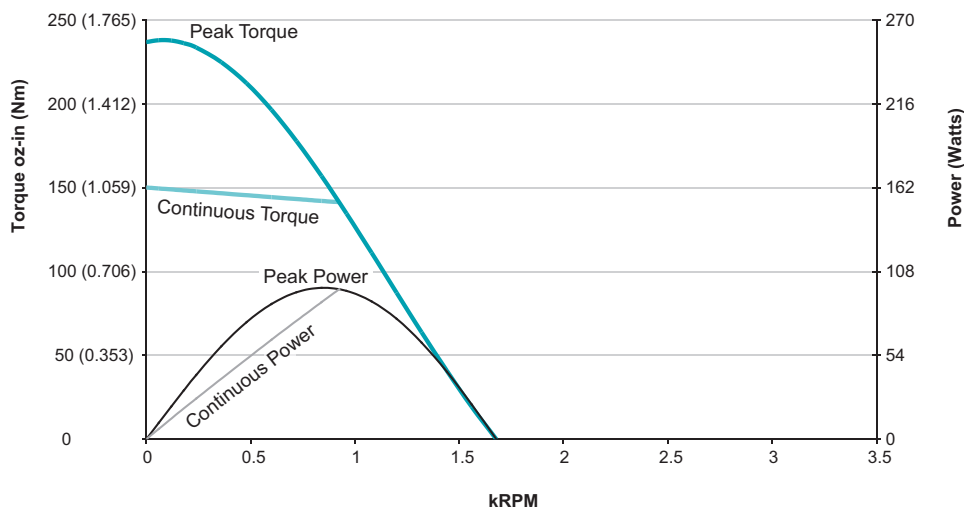

**SM34165D**  
**at 24 VDC**  
**at rise to 85°C**

All torque curves based on 25°C ambient.  
Motors were operated using MDT (Trapezoidal Drive Mode) Commutation.  
For ambient temperatures above 25°C, Continuous Torque must be linearly derated to 0% at 85°C.

SM34165DT		
Continuous Torque	12.83	in-lb
	205	oz-in
	1.45	N-m
Peak Torque	30.00	in-lb
	480	oz-in
	3.39	N-m
Nominal Continuous Power	615	Watt
No Load Speed	5,100	RPM
Max. Continuous Current* @ 4500 RPM	16.93	Amps
Peak Power @ 3400 RPM	930	Watts
Voltage Constant	8.9	V/kRPM
Inductance	0.32	mH
Encoder Resolution	8,000	Counts/Rev
Rotor Inertia	0.0142	oz-in-sec <sup>2</sup>
	10.031	10 <sup>-5</sup> Kg-m <sup>2</sup>
Weight	5.5	lb
	2.49	kg
Shaft Diameter	0.500	in
	12.70	mm
Shaft, Radial Load	30	lb
	13.61	kg
Shaft, Axial Thrust Load	3	lb
	1.36	kg
DeviceNet Available	Yes	
PROFIBUS Available	Yes	
CANopen Available	Yes	



Operating temperature range: 0°C–85°C

Storage temperature range: -10°C–85°C, noncondensing

**NOTE: Motor specifications are subject to changes without notice. Consult website and factory for latest data.**



\*Default voltage is 48V. See graphs for additional voltages.

## Moog Animatics SmartMotor™ SM34165DT (No Options) CAD Drawing

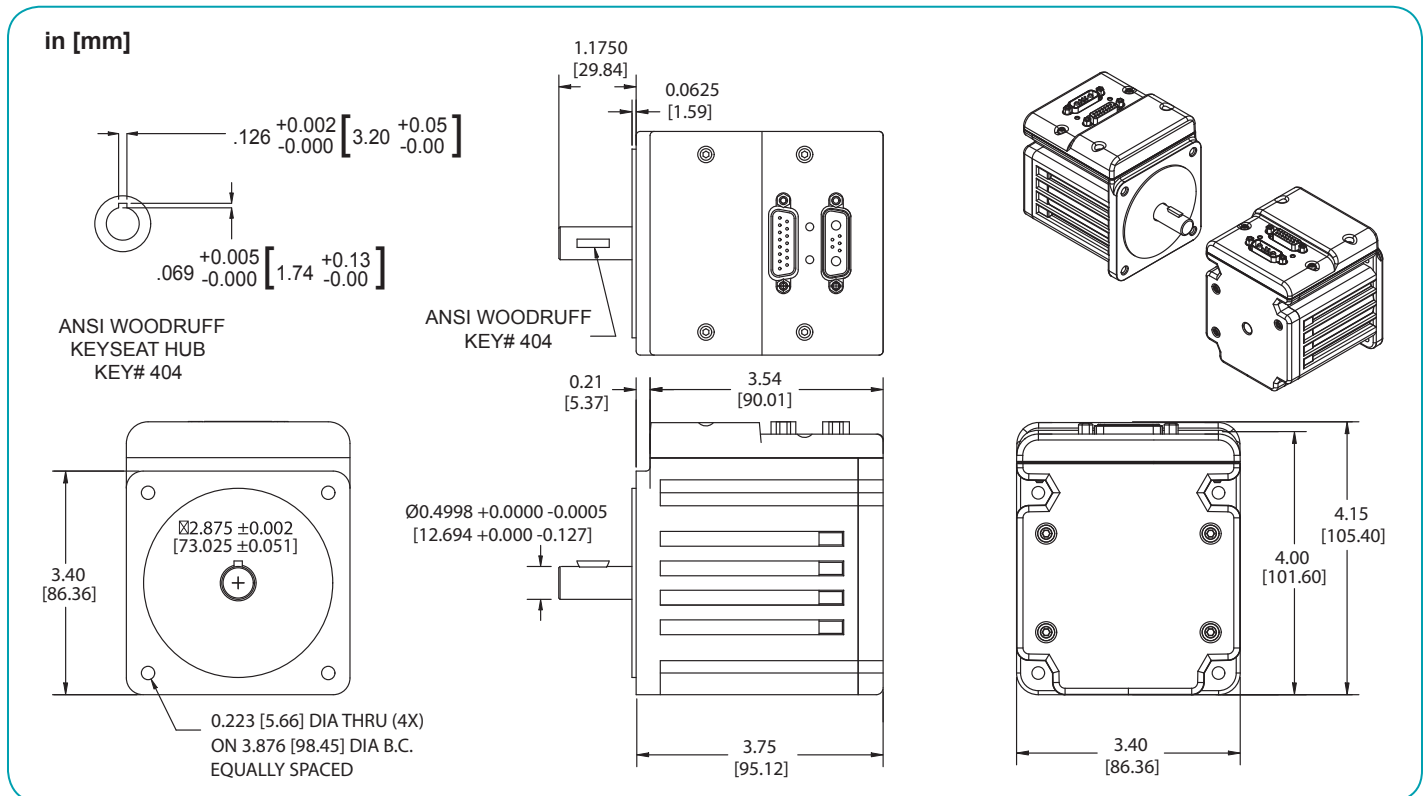

- OVERVIEW
- SOFTWARE
- D-STYLE MOTORS
- D-STYLE CONNECTIVITY
- PERIPHERALS
- M-STYLE MOTORS
- M-STYLE CONNECTIVITY
- LINEAR SYSTEMS
- POWER SUPPLIES & SHUNTS
- GEAR HEADS
- APPENDIX

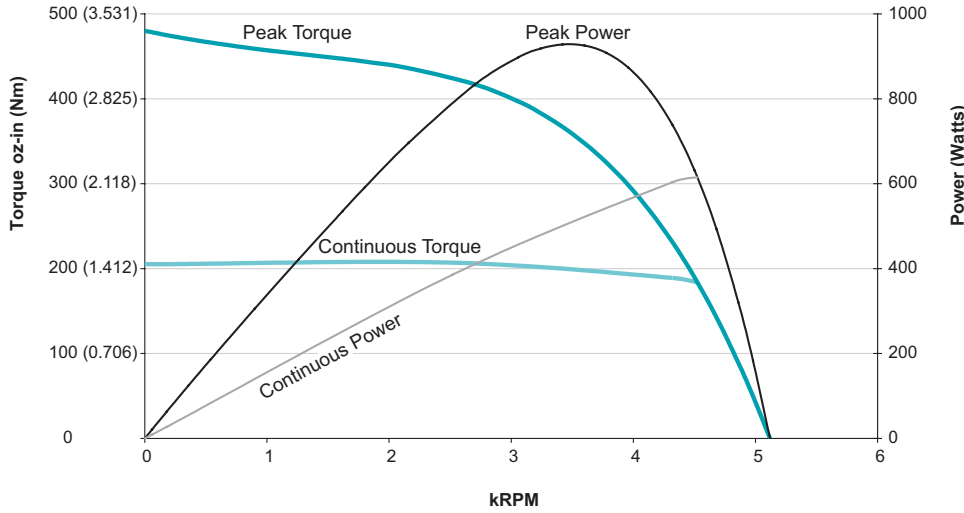

**SM34165DT**  
**at 48 VDC**  
**at rise to 85°C**

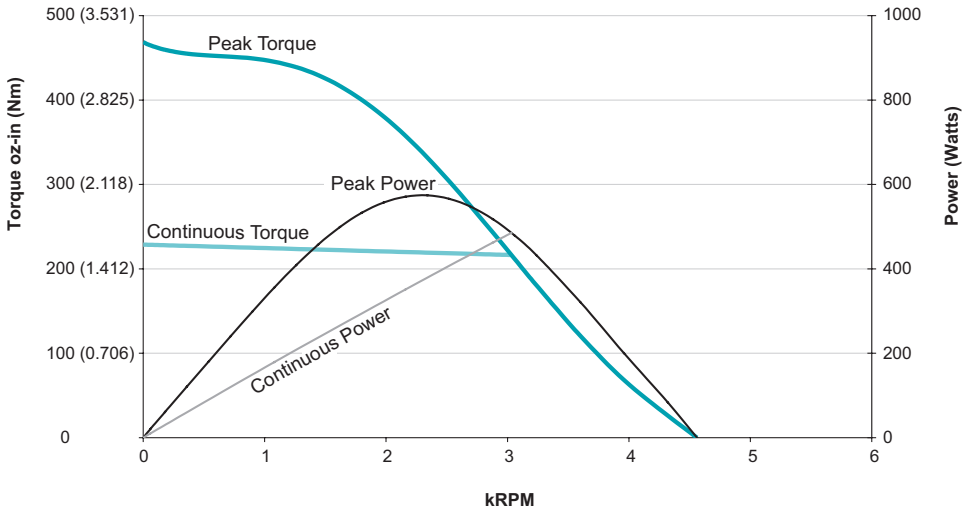

**SM34165DT**  
**at 42 VDC**  
**at rise to 85°C**

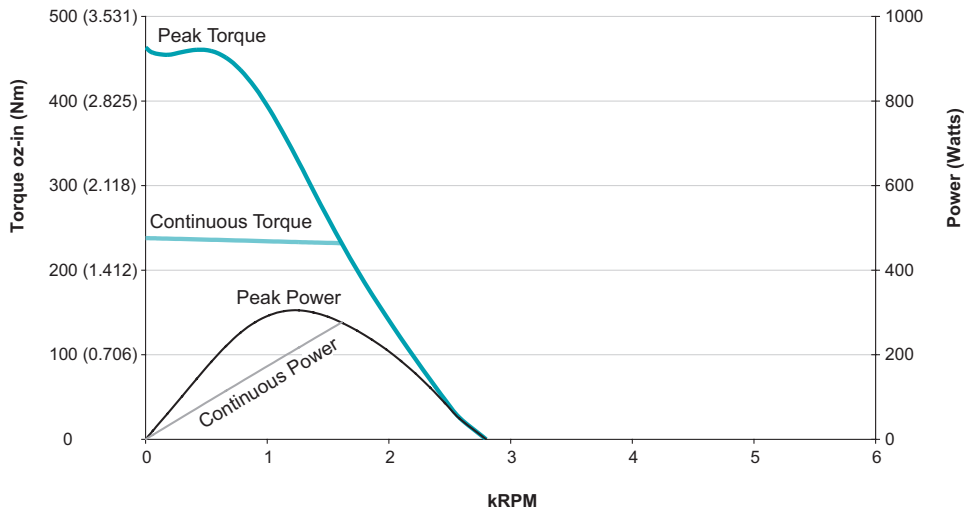

**SM34165DT**  
**at 24 VDC**  
**at rise to 85°C**

All torque curves based on 25°C ambient.  
 Motors were operated using MDT (Trapezoidal Drive Mode) Commutation.  
 For ambient temperatures above 25°C, Continuous Torque must be linearly derated to 0% at 85°C.

SM34205D		
Continuous Torque	7.91	in-lb
	126	oz-in
	0.89	N-m
Peak Torque	24.91	in-lb
	399	oz-in
	2.81	N-m
Nominal Continuous Power	324	Watt
No Load Speed	4,500	RPM
Max. Continuous Current* @ 3750 RPM	8.28	Amps
Peak Power @ 2250 RPM	455	Watts
Voltage Constant	10.8	V/kRPM
Inductance	0.596	mH
Encoder Resolution	8,000	Counts/Rev
Rotor Inertia	0.012	oz-in-sec <sup>2</sup>
	8.448	10 <sup>-5</sup> Kg-m <sup>2</sup>
Weight	3.5	lb
	1.59	kg
Shaft Diameter	0.375	in
	9.53	mm
Shaft, Radial Load	15	lb
	6.80	kg
Shaft, Axial Thrust Load	3	lb
	1.36	kg
DeviceNet Available	Yes	
PROFIBUS Available		
CANopen Available	Yes	

\*Default voltage is 48V. See graphs for additional voltages.



Operating temperature range: 0°C–85°C  
Storage temperature range: -10°C–85°C, noncondensing

**NOTE: Motor specifications are subject to changes without notice. Consult website and factory for latest data.**



## Moog Animatics SmartMotor SM34205D (No Options) CAD Drawing

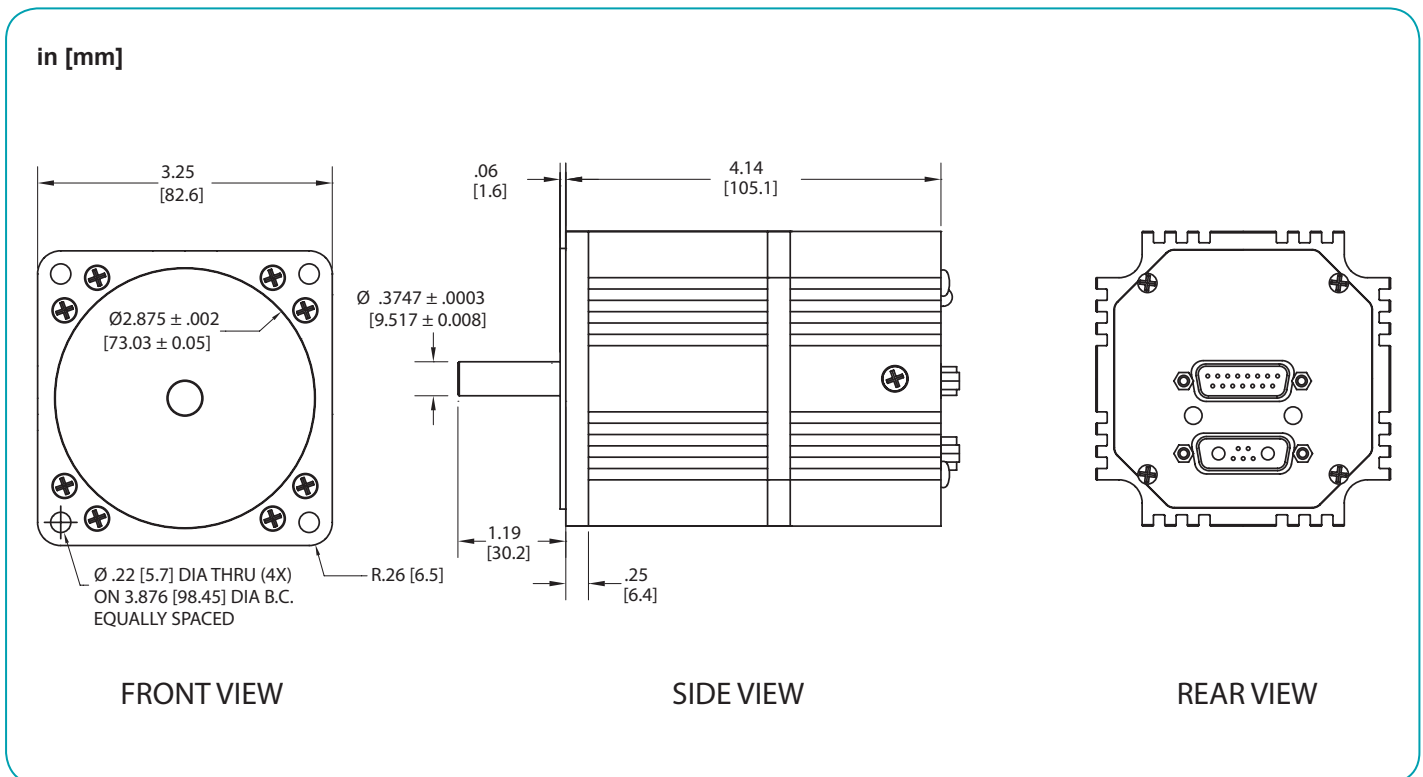

OVERVIEW  
SOFTWARE  
D-STYLE MOTORS  
D-STYLE CONNECTIVITY  
PERIPHERALS  
M-STYLE MOTORS  
M-STYLE CONNECTIVITY  
LINEAR SYSTEMS  
POWER SUPPLIES & SHUNTS  
GEAR HEADS  
APPENDIX

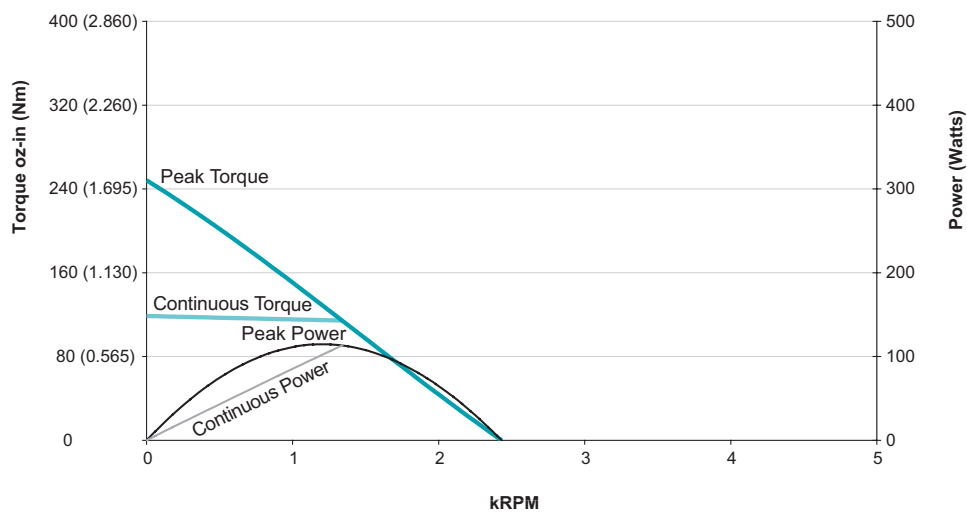
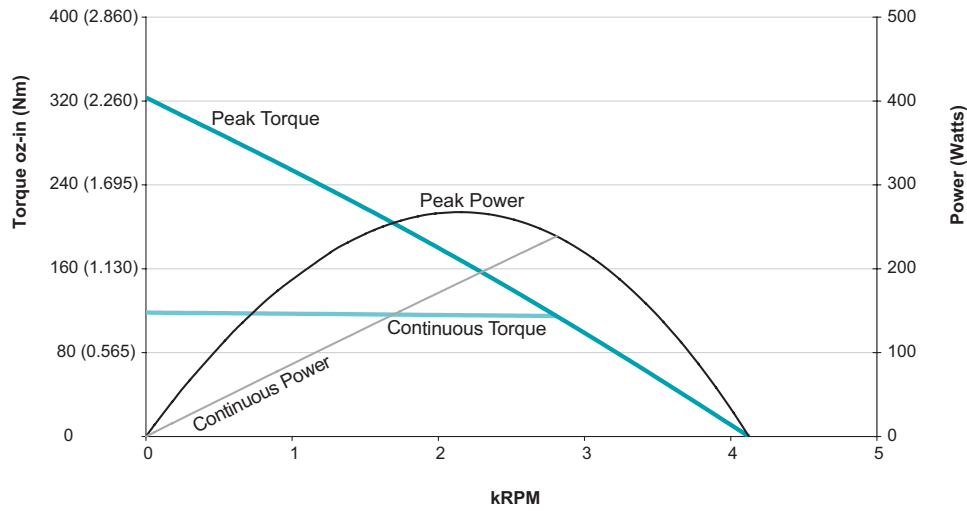
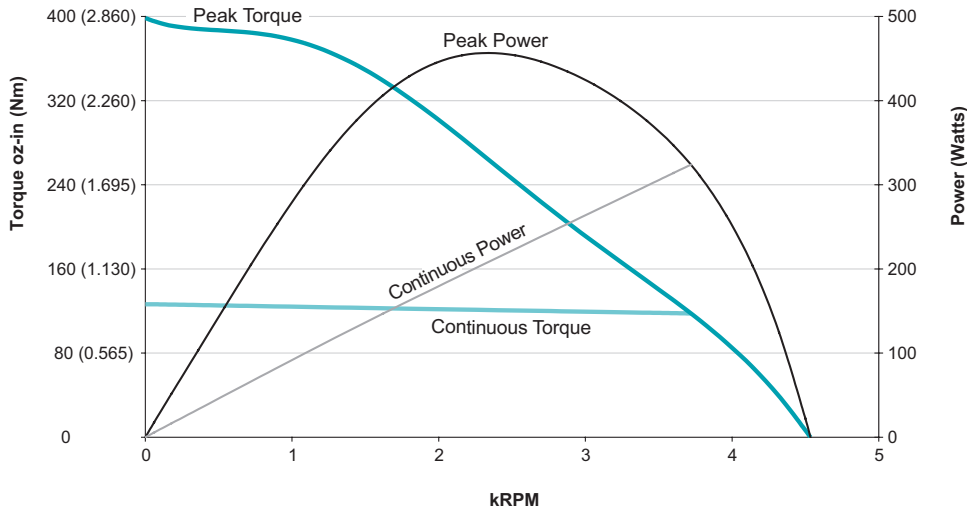

All torque curves based on 25°C ambient.  
Motors were operated using MDT (Trapezoidal Drive Mode) Commutation.  
For ambient temperatures above 25°C, Continuous Torque must be linearly derated to 0% at 85°C.

SM34305D		
Continuous Torque	10.87	in-lb
	174	oz-in
	1.23	N-m
Peak Torque	34.75	in-lb
	556	oz-in
	3.93	N-m
Nominal Continuous Power	400	Watt
No Load Speed	4,100	RPM
Max. Continuous Current* @ 3600 RPM	10.31	Amps
Peak Power @ 2500 RPM	725	Watts
Voltage Constant	12.1	V/kRPM
Inductance	0.490	mH
Encoder Resolution	8,000	Counts/Rev
Rotor Inertia	0.018	oz-in-sec <sup>2</sup>
	12.56	10 <sup>-5</sup> Kg-m <sup>2</sup>
Weight	4.5	lb
	2.04	kg
Shaft Diameter	0.375	in
	9.53	mm
Shaft, Radial Load	15	lb
	6.80	kg
Shaft, Axial Thrust Load	3	lb
	1.36	kg
DeviceNet Available	Yes	
PROFIBUS Available		
CANopen Available	Yes	

\*Default voltage is 48V. See graphs for additional voltages.



Operating temperature range: 0°C–85°C  
Storage temperature range: -10°C–85°C, noncondensing

**NOTE:** Motor specifications are subject to changes without notice. Consult website and factory for latest data.



## Moog Animatics SmartMotor SM34305D (No Options) CAD Drawing

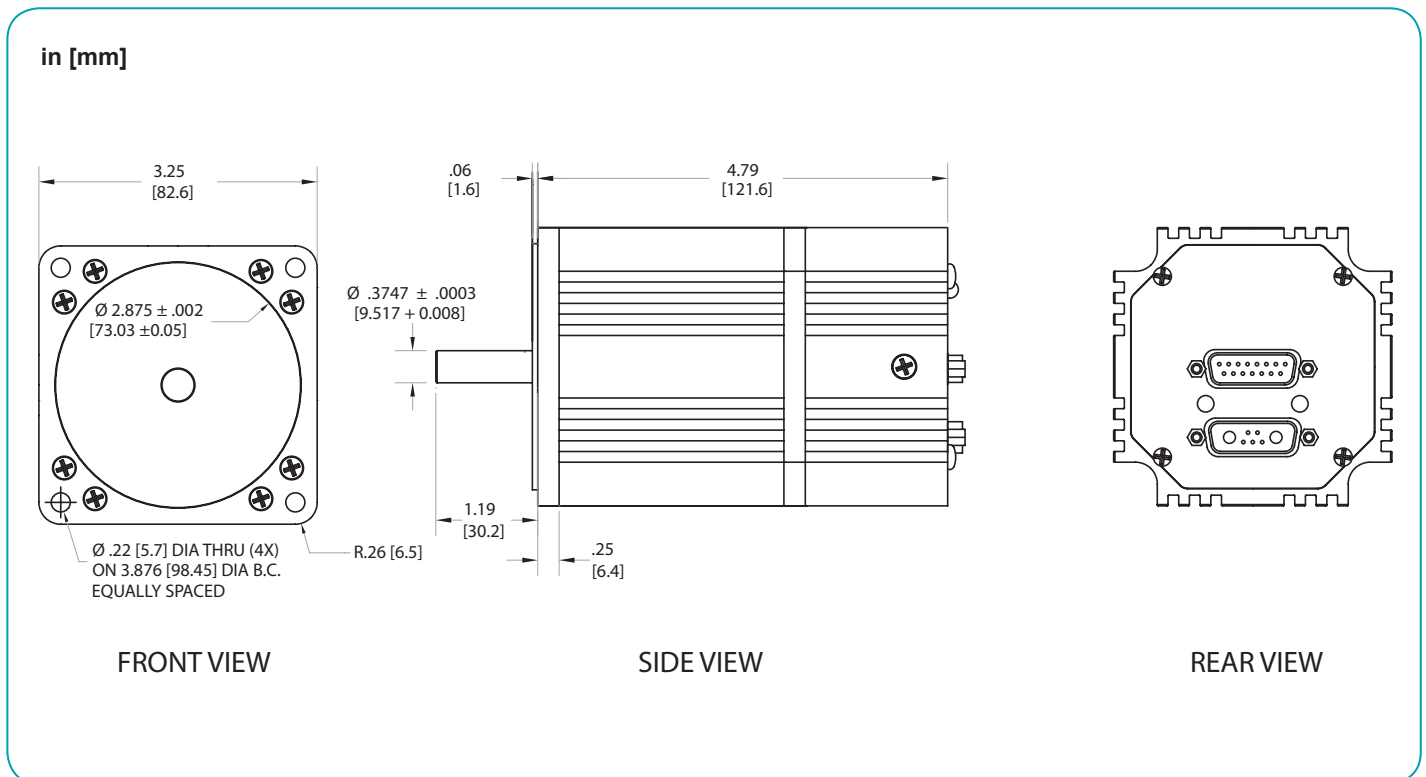

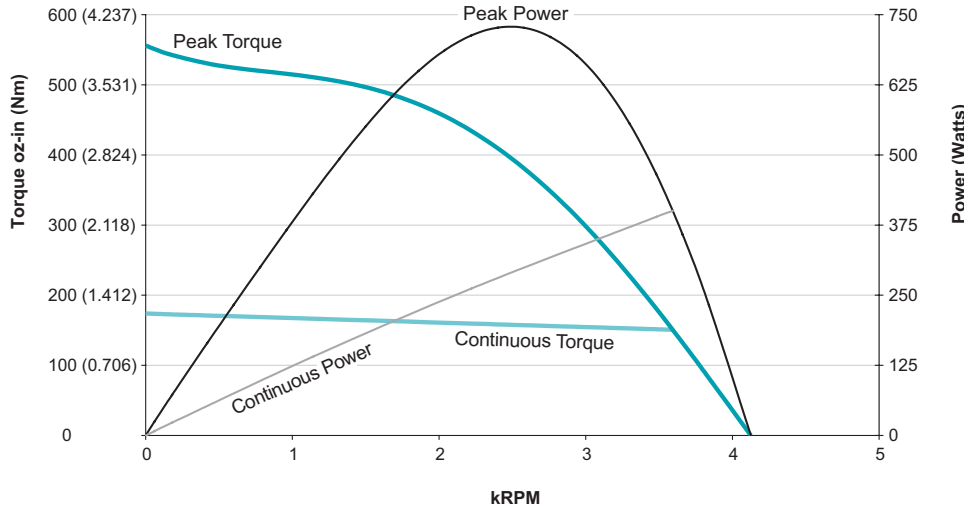

**SM34305D**  
at 48 VDC  
at rise to 85°C

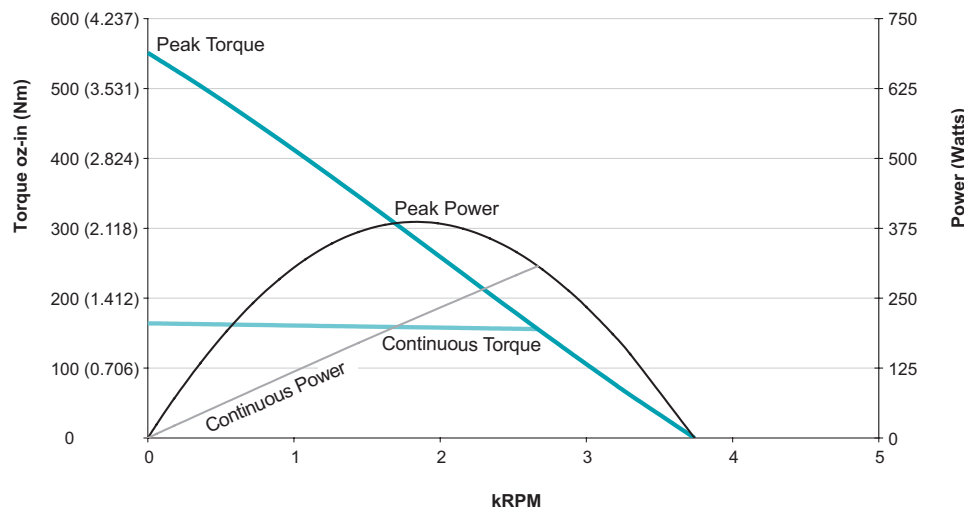

**SM34305D**  
at 42 VDC  
at rise to 85°C

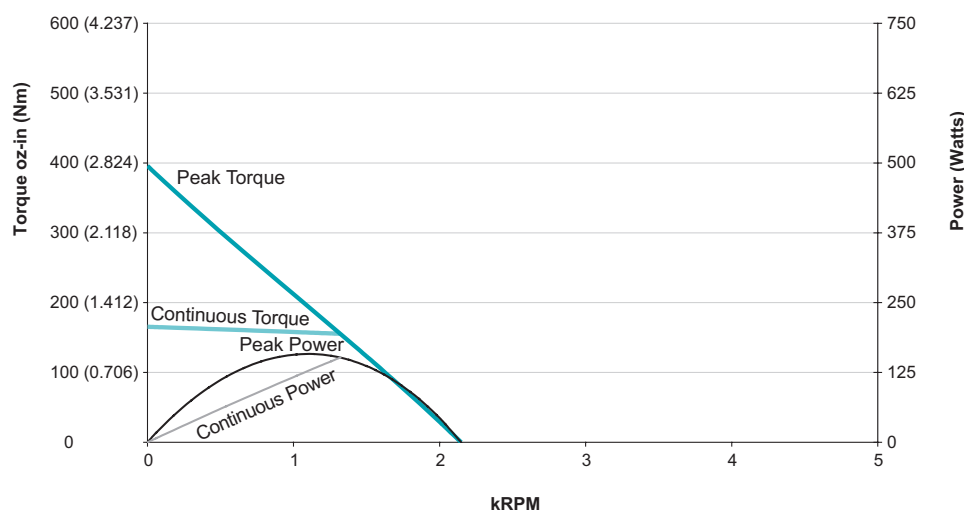

**SM34305D**  
at 24 VDC  
at rise to 85°C

All torque curves based on 25°C ambient.  
Motors were operated using MDT (Trapezoidal Drive Mode) Commutation.  
For ambient temperatures above 25°C, Continuous Torque must be linearly derated to 0% at 85°C.



SM34405D		
Continuous Torque	12.94	in-lb
	207	oz-in
	1.46	N-m
Peak Torque	40.38	in-lb
	646	oz-in
	4.56	N-m
Nominal Continuous Power	438	Watt
No Load Speed	3,800	RPM
Max. Continuous Current* @ 3300 RPM	11.69	Amps
Peak Power @ 2350 RPM	820	Watts
Voltage Constant	12.9	V/kRPM
Inductance	0.913	mH
Encoder Resolution	8,000	Counts/Rev
Rotor Inertia	0.024	oz-in-sec <sup>2</sup>
	17.020	10 <sup>-5</sup> Kg-m <sup>2</sup>
Weight	5.5	lb
	2.49	kg
Shaft Diameter	0.375	in
	9.53	mm
Shaft, Radial Load	15	lb
	6.80	kg
Shaft, Axial Thrust Load	3	lb
	1.36	kg
DeviceNet Available	Yes	
PROFIBUS Available		
CANopen Available	Yes	



Operating temperature range: 0°C–85°C  
 Storage temperature range: -10°C–85°C, noncondensing

**NOTE: Motor specifications are subject to changes without notice. Consult website and factory for latest data.**



\*Default voltage is 48V. See graphs for additional voltages.

## Moog Animatics SmartMotor SM34405D (No Options) CAD Drawing

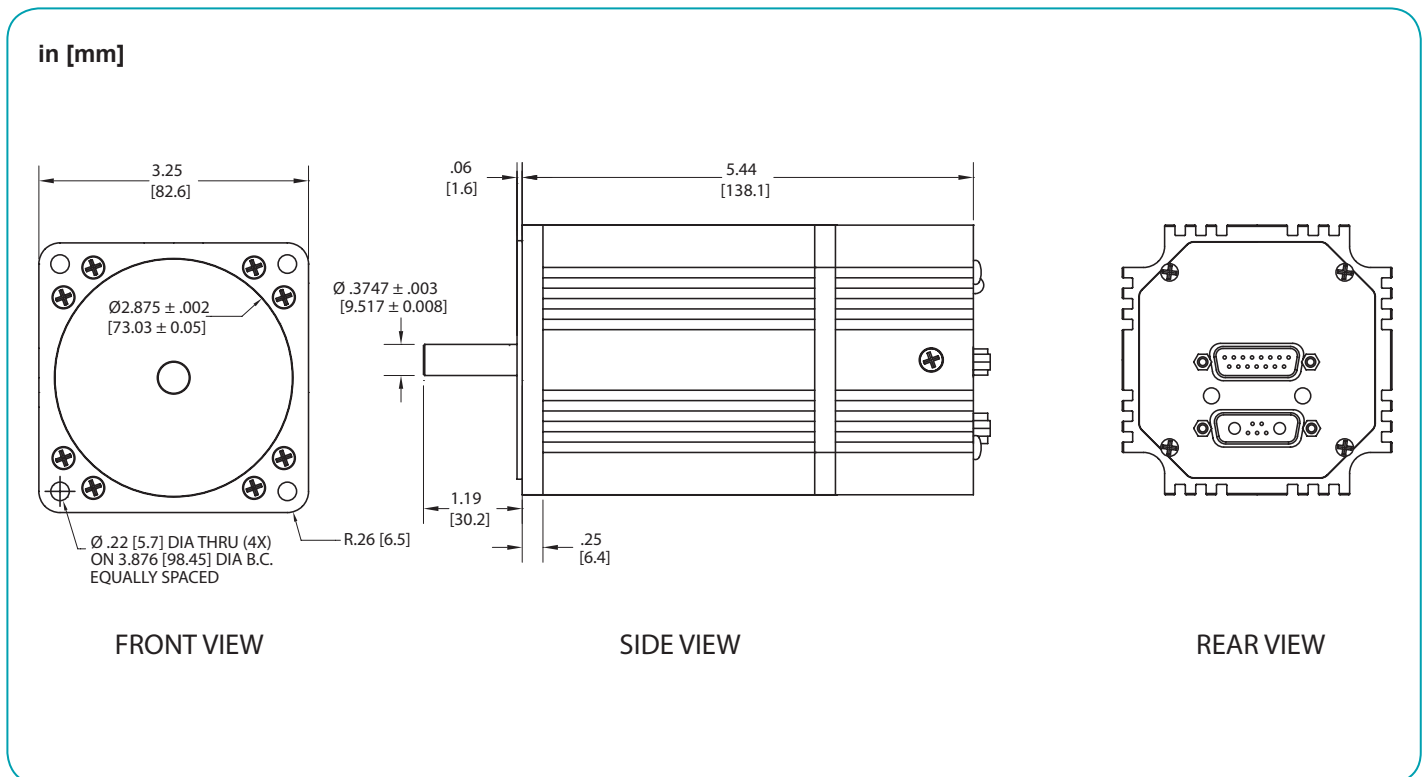

OVERVIEW  
SOFTWARE  
D-STYLE MOTORS  
D-STYLE CONNECTIVITY  
PERIPHERALS  
M-STYLE MOTORS  
M-STYLE CONNECTIVITY  
LINEAR SYSTEMS  
POWER SUPPLIES & SHUNTS  
GEAR HEADS  
APPENDIX

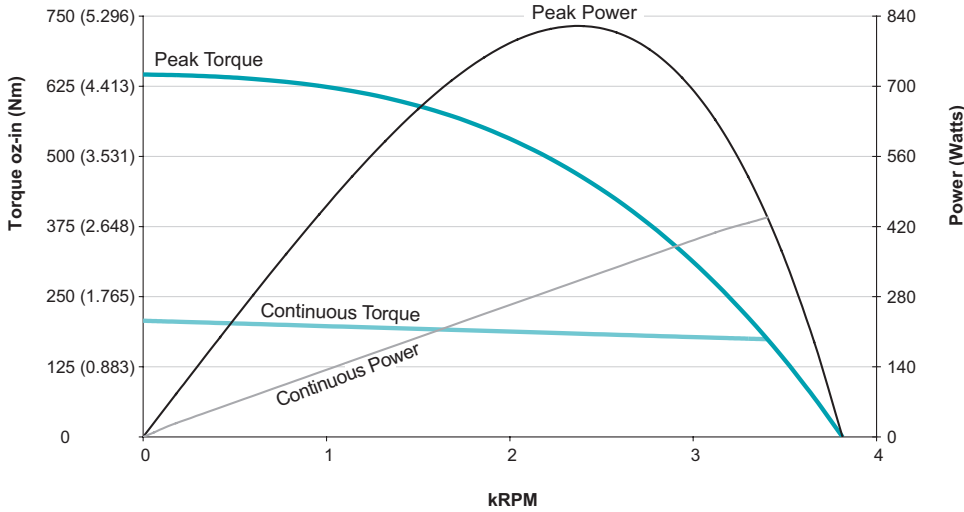

**SM34405D  
at 48 VDC  
at rise to 85°C**

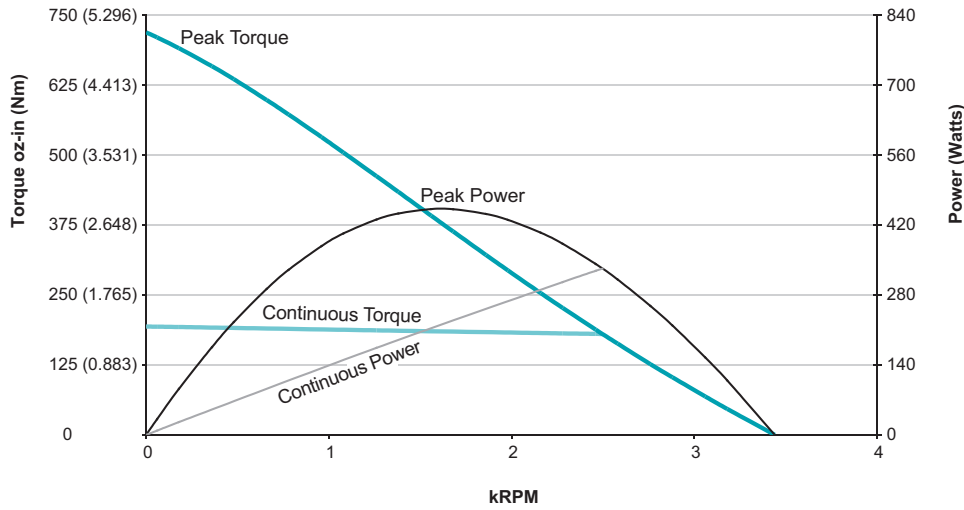

**SM34405D  
at 42 VDC  
at rise to 85°C**

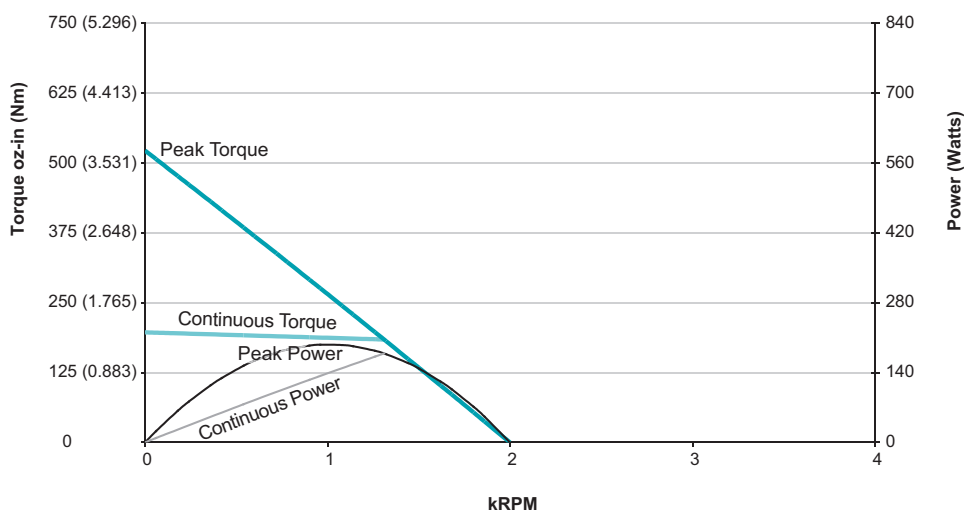

**SM34405D  
at 24 VDC  
at rise to 85°C**

All torque curves based on 25°C ambient.  
Motors were operated using MDT (Trapezoidal Drive Mode) Commutation.  
For ambient temperatures above 25°C, Continuous Torque must be linearly derated to 0% at 85°C.

SM34505D		
Continuous Torque	16.34	in-lb
	261	oz-in
	1.85	N-m
Peak Torque	48.19	in-lb
	771	oz-in
	5.44	N-m
Nominal Continuous Power	527	Watt
No Load Speed	3,300	RPM
Max. Continuous Current* @ 3100 RPM	14.37	Amps
Peak Power @ 2250 RPM	925	Watts
Voltage Constant	14.049	V/kRPM
Inductance	0.871	mH
Encoder Resolution	8,000	Counts/Rev
Rotor Inertia	0.03	oz-in-sec <sup>2</sup>
	20.92	10 <sup>-5</sup> Kg-m <sup>2</sup>
Weight	6.5	lb
	2.95	kg
Shaft Diameter	0.375	in
	9.53	mm
Shaft, Radial Load	15	lb
	6.80	kg
Shaft, Axial Thrust Load	3	lb
	1.36	kg
DeviceNet Available	Yes	
PROFIBUS Available		
CANopen Available	Yes	

\*Default voltage is 48V. See graphs for additional voltages.



Operating temperature range: 0°C–85°C  
Storage temperature range: -10°C–85°C, noncondensing

**NOTE: Motor specifications are subject to changes without notice. Consult website and factory for latest data.**



## Moog Animatics SmartMotor SM34505D (No Options) CAD Drawing

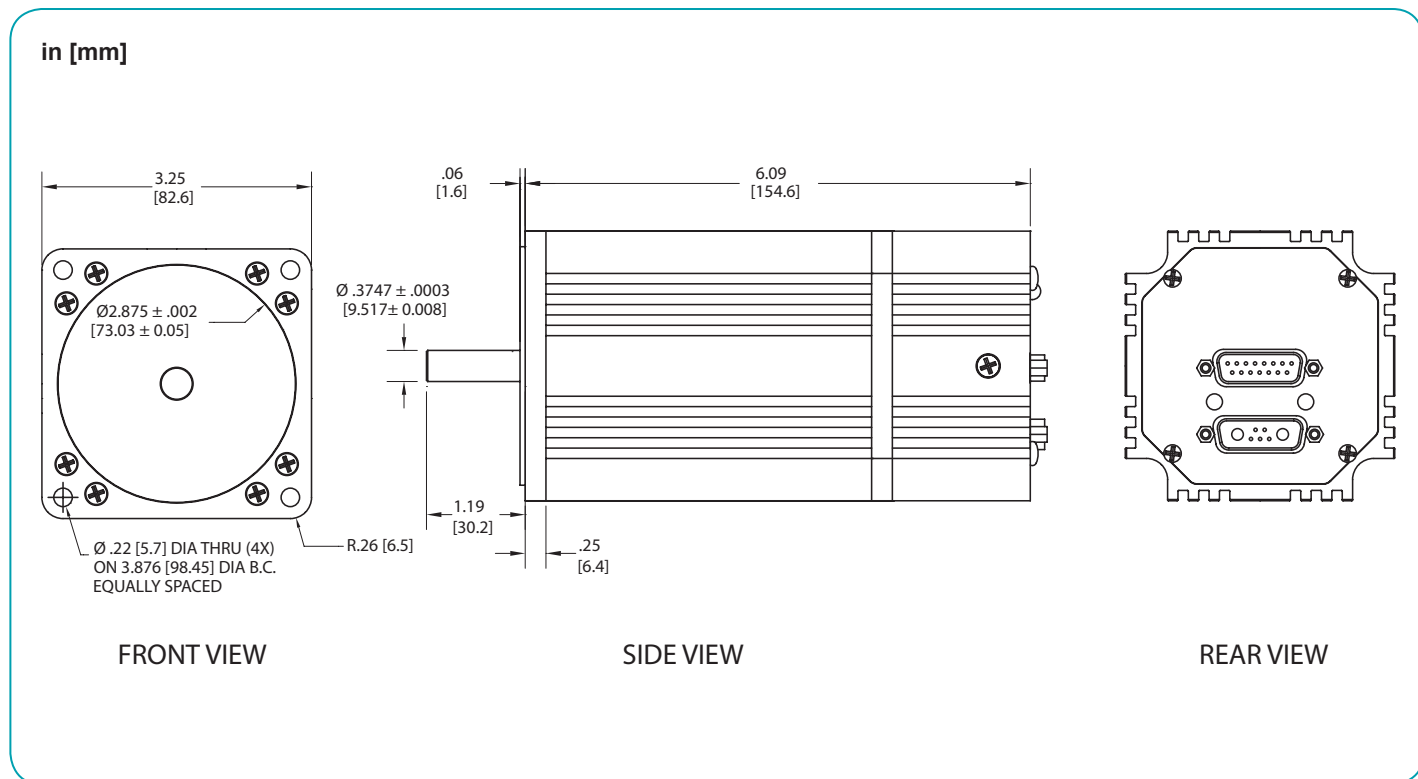

OVERVIEW  
SOFTWARE  
D-STYLE MOTORS  
D-STYLE CONNECTIVITY  
PERIPHERALS  
M-STYLE MOTORS  
M-STYLE CONNECTIVITY  
LINEAR SYSTEMS  
POWER SUPPLIES & SHUNTS  
GEAR HEADS  
APPENDIX

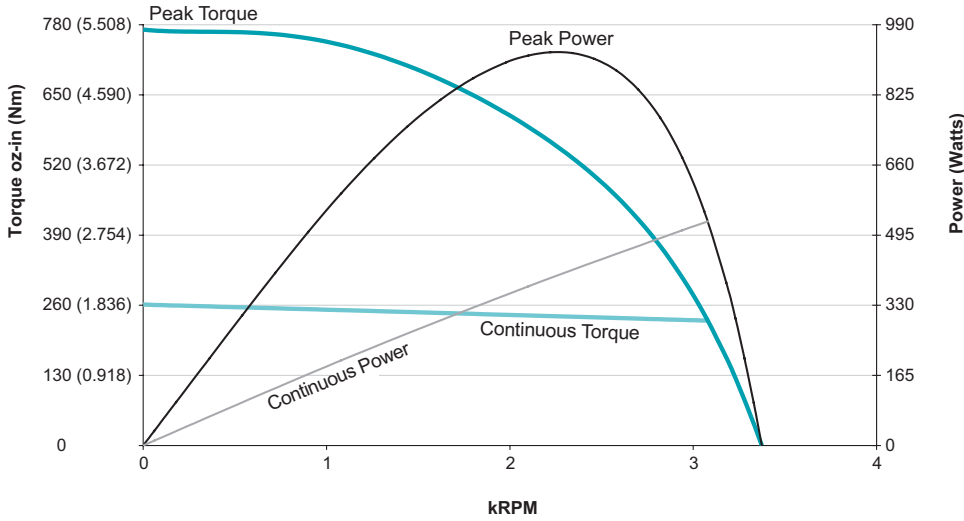

**SM34505D  
at 48 VDC  
at rise to 85°C**

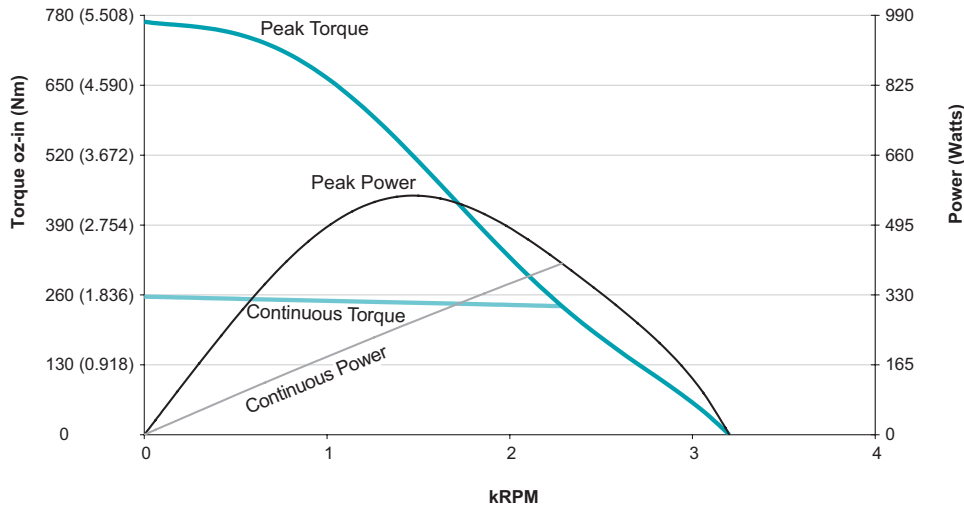

**SM34505D  
at 42 VDC  
at rise to 85°C**

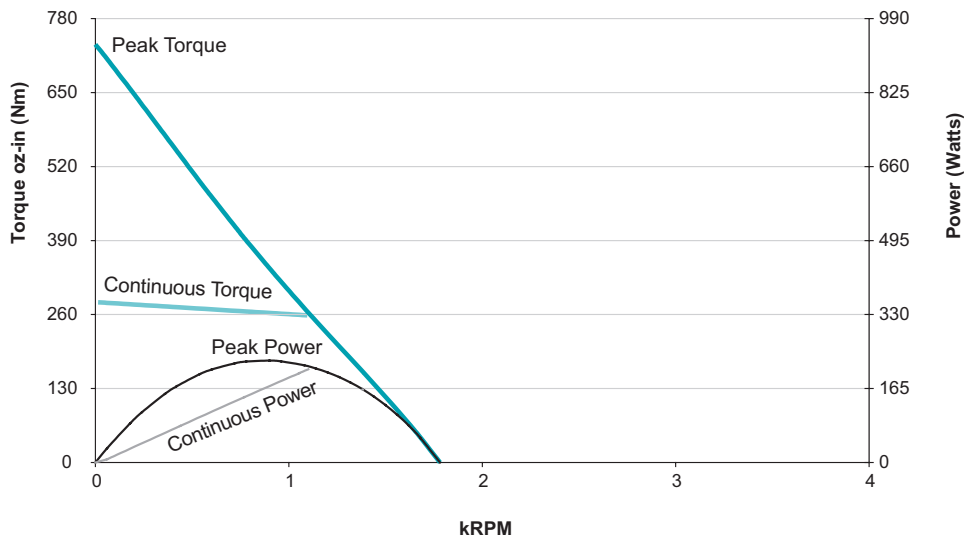

**SM34505D  
at 24 VDC  
at rise to 85°C**

All torque curves based on 25°C ambient.  
Motors were operated using MDT (Trapezoidal Drive Mode) Commutation.  
For ambient temperatures above 25°C, Continuous Torque must be linearly derated to 0% at 85°C.