

Contents

Data RFID Identification Systems

Control Interfaces IDENTControl 922

Control Interfaces IDENTControl Compact 923

Read/Write Heads 924, 926, 927

Read/Write Heads for Hazardous Areas 925

RFID Tags 928

R/W Station and Mounting Bases 937

R/W Station and Tags 2.45 GHz..... 938

Handheld Devices 939

Identification Systems RFID

8





RFID Identification Systems

8.1 Introduction 918

8.2 Frequencies..... 918

8.3 High-Performance Components Offer Maximum Flexibility 918

8.4 RFID Handheld Devices 920

8.1 Introduction



RFID stands for “radio frequency identification,” a wireless, noncontact technology that identifies a person or object using a radio frequency transmission, typically 125 kHz (low frequency) or 13.56 MHz (high frequency). Typically, identification systems consist of a control unit, read/write heads, and tags.

The tags are embedded or attached to an item where unique identification and customer specific information can be saved. The read/write memory areas can range up to 16 kbits. Read/write heads can read the tag and modify the read/write portion as required by the application. This is done with a series of commands sent from the PLC, to the control unit, to the read/write heads, and finally, to the tag.

Several read/write heads can be connected to one control unit, which also serves as the interface to the PLC/PC. Communication takes place via the dominant industrial fieldbuses such as Ethernet, PROFIBUS, DeviceNet, or via a serial interface. Wiring between the control unit and the read/write heads is accomplished using shielded cables in order to reduce the influence of EMC in the environment.

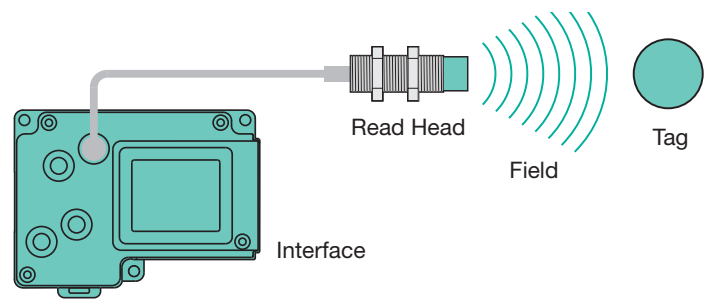

8.2 Frequencies

Two different frequency ranges are available and each has its advantages and industries where it is often used: low frequency, 125 kHz systems and high frequency, 13.56 MHz systems.

Low-frequency systems

The low-frequency systems typically have a few inches of read range, are highly immune to metal in the environment and have good field penetration of water, grease and other nonmetallic substances. The wound coil required in a low frequency system makes the tag moderately expensive and typically requires the tags to be reusable and not disposable. This frequency range is typically used in factory automation, tool identification, closed loop parts tracking, animal tracking and inventory control.

High-frequency systems

High-frequency systems* allow a smaller coil size, which makes the tag less expensive. It is often used in logistical applications, asset tracking, and select factory floor applications. The low cost makes this tag perfect for high tag volume applications. Recent advancements allow these tags to be embedded in metal and are, therefore, also appropriate for tool identification. In addition to being low cost, they are up to 10 times faster than the low-frequency versions.

*Available in ISO 15693 and 14443

8.3 High-Performance Components Offer Maximum Flexibility

IDENTControl interfaces

The IDENTControl interface is the backbone of our latest RFID system solution. It connects directly to your PC/PLC of choice and manages all communications to and from the read heads. Read heads are configured on power up, and parameters, like multiplex mode and tag type, are set automatically.

The advantage is not merely the simplicity of the system, but the easy and universal programming. No matter which head is used, the PLC or PC programming is the same. All heads use the same commands and all tags have the same addressing structure.

IDENTControl and IDENTControl Compact interfaces combine various RFID technologies and frequencies into one device. The same device operates high- frequency or low-frequency read/write heads and trigger sensors - unifying operation and programming. You can connect four read/write heads on one IDENTControl device—two read/write heads on one IDENTControl Compact device—and configure them directly on-site through integrated web servers, DIP switches, or display and function keys. Connecting to the web via Ethernet is no problem whatsoever. The advantages: Several control units can be set up via one central network PC. And, an SMS message is sent directly to you if your processes fail to run smoothly due to a hardware error message.

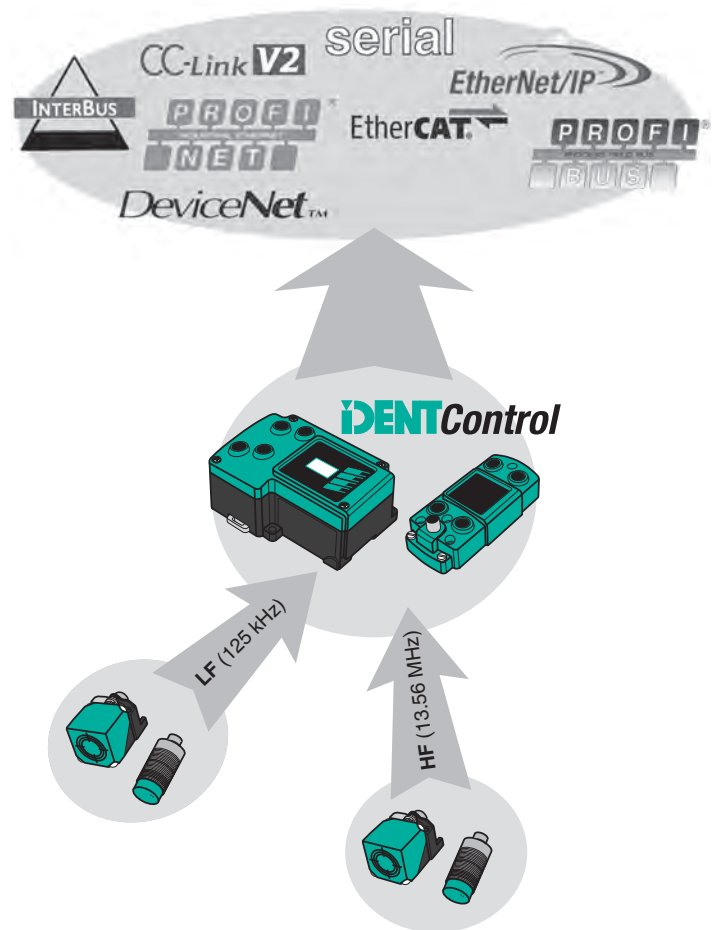

Mixed Mode vs. Separated Mode

A feature that could make you choose one interface over another is the mode of operation. You can read and write to all heads simultaneously. The key difference is the memory mapping in the PLC. In the mixed mode operation, all heads are mapped into the same PLC memory area. In separated mode, memory is set aside for each head. Mixed mode is great for reducing bus system overhead and separated mode is used for speed and programming ease.

Industrial Bus Connections

All bus connections are integral to IDENTControl. Just choose an interface, read head, and cable and you are done. All common industrial networking solutions are available: Ethernet, DeviceNet, PROFIBUS, CC-Link, and RS-232. The Ethernet interface will support multiple protocols, including EtherNet/IP, PROFINET, PCCC for SLC5/05 and PLC5 messaging, Modbus/TCP, and TCP/IP. IDENTControl also supports the real-time EtherCat Ethernet protocol. Protocol switching is automatic.

EtherNet/IP

The Ethernet interface supports EtherNet/IP right out of the box. With implicit messaging, the data is directly mapped just like any other I/O card. No expensive configuration software is required for setup. Everything is programmed using the RSLogix 5000 programming software.

DeviceNet

Because the DeviceNet current consumption is only 40 mA you can run 500 ft of DeviceNet cable with more than 84 read heads attached to it. DeviceNet also has automatic node replacement. With this feature, all parameters are downloaded to the interface on power up. These parameters may include the assembly instances, tag type of each head and multiplex mode.

PROFIBUS

Many PLCs use PROFIBUS as their high-speed bus connection. Various models are available that allow quick field or enclosure mounting. Parameterization is automatic, and the diagnostic interrupt allows signaling of the master system when an error occurs. Any type of read head connects directly to the IDENTControl interface.

CC-Link

This common upper-level bus system is used almost exclusively by Mitsubishi PLCs. These controllers also support CC-Link V2. This newer specification allows extended cyclic settings resulting in a large data map making it easier and faster to read and write large amounts of information to the RFID system. This two-head controller communicates to both read/write heads simultaneously and incorporates a new advanced RFID protocol. This powerful protocol gives positive feedback to the user when a new tag has arrived and allows for large read/write data blocks that are limited only by the read/write head's internal memory size.

PROFINET

PROFINET is a real-time industrial network with a fast RT (real time) protocol. It communicates on the MAC level, making the packets small and compact and, of course, extremely fast. The IP address of these devices does not matter. Instead, every device is assigned a PROFINET name. The network neighborhood function allows the master to know how each device is connected relative to one another. This allows a failed device to be removed and replaced with a new one without any extra user configuration. This reduces downtime and allows a potentially inexperienced maintenance crew to take care of the system.

SLC 5/05 and PLC 5 Read/Write Operation

The SLC5/05 Ethernet processor and the PLC5/xxE Ethernet processors do not use standard EtherNet/IP protocol, but a protocol called PCCC. This protocol is fully supported and two rungs of ladder will get you up and running quickly.

Modbus/TCP

Many PLCs, such as Schneider Electric and GE, will support the Modbus/TCP protocol. This protocol supports multiple simultaneous users: For instance, one PLC can control four heads or four PLCs can each control one head. This reduces the overall cost of the installation. The interface is protected against dual head write access.

TCP/IP

Standard socket connections to port 10000 will allow you to send and receive data to IDENT Control. An integrated Web server makes configuration, setup and testing easy and with the integrated SMTP server emails are sent on error or data.

EtherCAT

EtherCAT is another industrial Ethernet protocol designed for drives, IO, and RFID. This Ethernet network is essentially a ring of data. One large packet is sent out with every device's I/O included in it. The individual devices pull out the inputs and set the required outputs. This exchange of IO data takes only a few nanoseconds per device. No IP address or name is required for these devices. The location of a device within the string of EtherCAT devices determines devices are set up and how that device will operate on the network. Like PROFINET, a failed device can be removed and a new device installed without ever configuring it.

Read/write heads

With IDENTControl, all heads are read/write. There are no worries about purchasing the wrong head style so inventories are significantly reduced. Different housing designs are available for your application requirements.

All read heads fit and work on any IDENTControl interface.



How Do I Choose the Correct Head?

The first factor is the frequency. If you have chosen a tag then select a read head with the same frequency as the tag. Second, consider the IQH... type read heads. This line of RFID has a wide selection of tags and heads. Odds are that there is something in this line that will fit your application. Third, use the preceding table to determine which features you need for your application.

Read Speed

There are usually two speeds that are discussed when it comes to RFID. The first is how fast can the data be read off the tag, and the second is how fast can the tag fly by the read head and still be read. The second speed is based on the first, but it also takes into consideration the size of the head and size of the tag. Basically, the higher the frequency, the faster the data can be read; and the larger the head the faster the tag can pass the reader. See the RFID introduction to determine how each system performs.

Tags

There are over 50 different tags in a variety of housings and performance ratings. Tags can range in diameter from 8 mm to 58 mm. Industrial tags are designed for tough and abusive environments: very high or low temperatures, excessive wear and tear, and mounting in or on metal. Commercial tags are less costly and can be used where very little abuse is expected. We have the right tag for virtually any application.

Tag/Head Size Choices

It is important to note that if you choose a small tag, you should choose a small head. There is very little to be gained in a mismatch either way. The most efficient combinations are those where the head is similar in size to the tag.

	Series P	Series Q
Frequency	125 kHz	13.56 MHz
Transfer Rate	2 kbit/s	26 kbit/s
Tags Embeddable In Metal	Yes	Yes
High Temperature Tags	Yes	Yes
Tag Capacities (bits)	1k	1k, 2k, 64k
Max Read Range	125 mm	170 mm
Write Limits	100,000	100,000 or unlimited

System selection criteria

Cycle time

Typically, the higher the frequency the faster data can be transferred to and from the RFID tag. Other times must be taken into consideration to understand the complete system cycle time. You must take into consideration the following:

- Upper level bus-system scan times of networks like DeviceNet,



PROFIBUS, Ethernet, and RS-232 will change depending on network loading, baud rate, etc.

- PLC scan time: The PLC may only see the rung that receives the RFID data every 30 ms. The cycle time of the entire system cannot be faster than the PLC scan time.
- Data transfer to and from the tag

Data transfer time

Each frequency and each RFID family have different read/write times. The possible data rates depend on the communication frequency. A 125 kHz system offers typical data rates of 40/130 bytes per second (write/read) while a high frequency system offers 230 write/3000 read bytes per second. Additional time must be calculated for the data transfer on the fieldbus and processing in the PLC. This may be a determining factor for installation, and will be required if read-on-the-fly speeds need to be calculated. Typically, the more you want to read the more time it will take.

Maximum passing speed

The passing speed is calculated using the data transfer time between the tag & head, and the field size. The field size is based on the size of the read head. The larger the head the more time the tag can stay in the field and the faster the tag can pass. Being too close or too far away reduces system performance.

Generally, the following rule applies:

$$V_{max} = \frac{\text{Read field width [m]}}{\text{Read time [s]}}$$

For short range systems, if the object passes at about half the maximum read distance, the diagonal of the read head can be used as the read field width if the code/data carrier has roughly the same diameter as the read head.

Typically only 1/2 to 1/3 of the maximum passing speed is recommended for practical use. This will allow for retries required due to noise and interference on the line. Though retries are highly unlikely they are a necessity on any industrial interface.

Advantages of the IDENTControl system

- The system is completely shielded and can be easily connected with a ground potential. The read head cables are also shielded to provide the highest level of EMC safety.
- Up to four read/write heads can be connected and a mixed mode of different frequency ranges is possible.
- Trigger sensors can be connected to start read/write commands.

- The quick disconnect design means that all components can be connected easily and swapped over quickly
- The 24 VDC power supply is obtained through a separate M12 plug; a red LED indicates reverse polarity, a green LED indicates correct power connection.
- The robust metal housing can be mounted to the DIN mounting rail in the control cabinet using the integrated snap-on hook (IDENTControl) or suitable mounting aids (IDENTControl Compact). Three mounting holes make it suitable for field mounting in IP67 applications.

8.4 RFID Handheld Devices

Product description

Our handheld devices represent a mobile extension of the IDENTControl system. RFID handheld devices are available for LF and HF tags. The read data can be stored in the device and assigned a prefix, suffix, timestamp, and checksum, enabling the devices to be safely integrated into logistics and production processes.



LC display and keyboard

The design is similar to that of a cell phone and is intuitive to use. The handheld device has a keyboard and a multiline display.

Application-specific functions

The JavaScript programming language is used to control the display, execute all the commands in a routine, and assign soft keys. If you wish to configure your own interface for the device, please contact Pepperl+Fuchs.

Interfaces

The handheld device has different interfaces through which it can communicate with a computer. In addition to the wireless Bluetooth interface, the handheld device also has RS232, PS/2, and USB wired interfaces. You set the parameters of the individual interfaces directly via the user interface on the handheld device. Compatible interface accessories are available from Pepperl+Fuchs.

Power supply

A lithium-ion battery provides power to the handheld device. Batteries and battery chargers are available from Pepperl+Fuchs.

IDENTControl

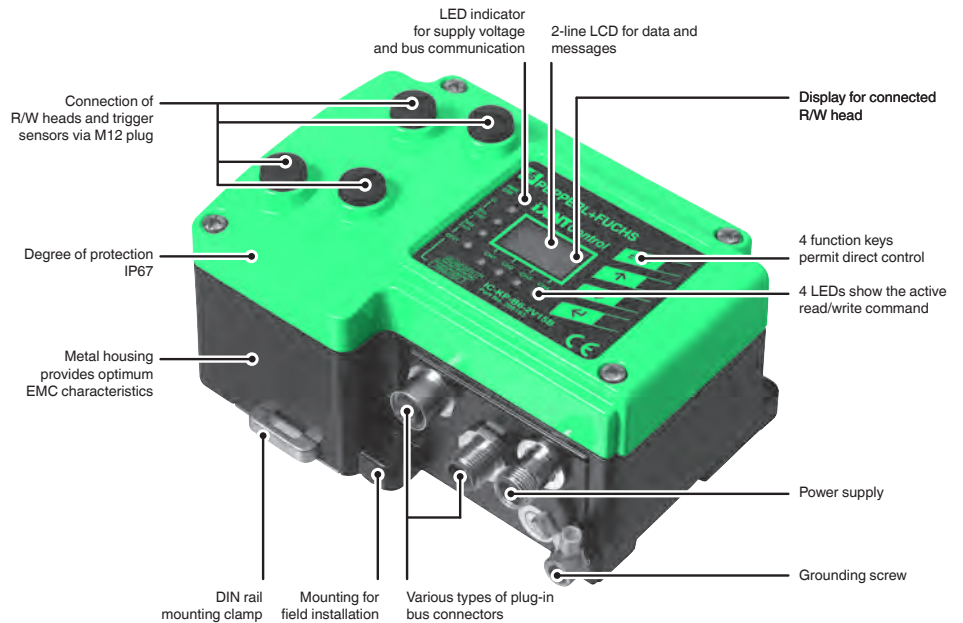

IDENTControl Compact

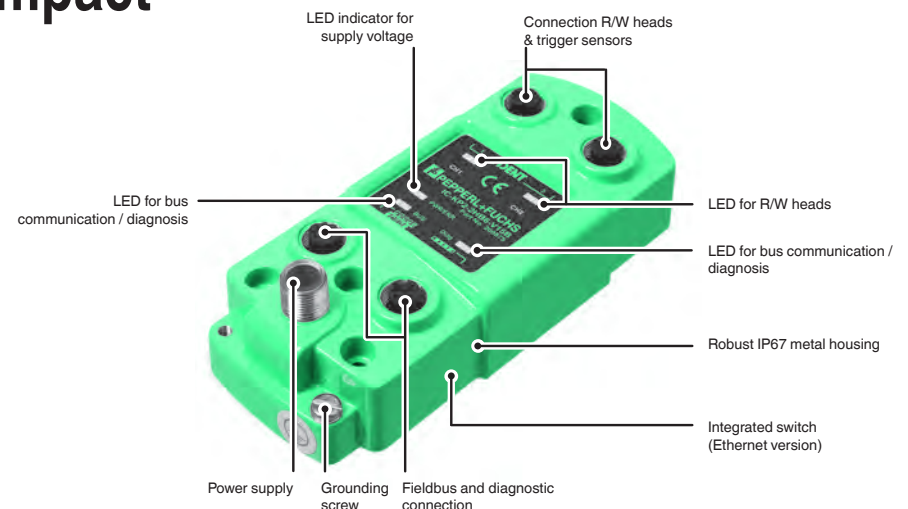



Properties

- DeviceNet, Ethernet, PROFIBUS, PROFINET, InterBus, RS 232, EtherNet/IP and MODBUS/TCP interface versions
- Max. 4 R/W heads connectable

Benefits

- All IDENTControl interfaces support all IPH and IQH R/W heads
- Metal housing and continuous shielding concept result in exceptional noise resistance
- Common user interface makes application development for different PLCs simpler and faster
- Quick disconnect design speeds up installation and eliminates wiring errors
- LCD and function keys allow faster on-site setup and testing

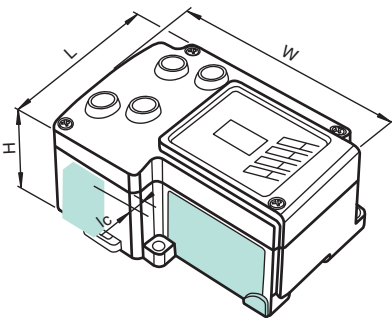

Technical Data

For detailed data and product description refer to the data sheets at www.pepperl-fuchs.us

General Data

Number of read/write heads	max. 4 alternative 2 read/write heads and 2 trigger sensors
UL File Number	E87056
LC display	two-line multi-function display with 12 characters per line
Button	4 keys: ESC, up, down and return
Rated operational voltage	20 ... 30 V DC, PELV
Ambient temperature	-25 ... 70 °C (-13 ... 158 °F)
Housing material	Powder coated zinc
Installation	snap-on to 35 mm standard rail or screw fixing

Model Number

	IC-KP-B17-AIDA1	IC-KP-B6-V23	IC-KP-B6-2V15B	IC-KP-B6-SUBD	IC-KP-B6-V15B	IC-KP-B7-V95	IC-KP-R2-V1
Current consumption	≤ 2 A incl. read/write heads	●	●	●	●	●	●
	≤ 8 A incl. read/write heads	●	●	●	●	●	●
Interface:							
Protocol	MODBUS/TCP / TCP/IP	●					
	EtherNet/IP / PROFINET IO	●					
	INTERBUS		●				
	PROFIBUS DP			●	●		
	DeviceNet					●	
	ASCII RS 232						●
Connector							
	AIDA	●					
	M23		●				
	2 x M12, B-coded			●			
	9-pin Sub-D				●		
	M12, B-coded					●	
	Mini-style						●
	M12, A-coded						●
Protection degree							
	IP40			●			
	IP65	●	●				
	IP67	●	●	●	●	●	●

Dimensions

Length L [mm]	107
Width W [mm]	148
Height H [mm]	73
Connector area l _c [mm]	10

Accessories

These and more accessories can be found in chapter 10

See pages from 970 ... for cordsets See pages 1066 ... for mounting accessories

V1S-G-0,15M-PUR-ABG-SUBD	Adapter M12 on Sub-D for PC connection with null modem cable
ICZ-AIDA1-MSTB-0,2M-PUR-V1-G	Double-ended connector MSTB to M12 connector
ICZ-AIDA1-MSTB-5M-PUR	Connection cable MSTB to cable tail
ICZ-AIDA1-V45-0,2M-PUR-V1-D-G	RJ-45 connecting cable, D-coded to M12
ICZ-AIDA1-V45-5M-PUR-V45-G	Connecting cable RJ-45 to RJ-45, PUR cable 4-pole, CAT5e
V1-G-5M-PUR-ABG-V1-W	Double-ended connector, M12 to M12, PUR cable 4-pin, shielded
ICZ-AIDA1-B	Blind plug for IC-KP-B17-AIDA1
ICZ-AIDA1-MSTB	Field connector MSTB
V1-G-5M-PUR	Single-ended cordset, M12, 4-pin, PUR cable
V15B-G-*M-PUR-ABG-V15B-G	Data connector PROFIBUS, M12 to M12, PUR cable
V15B-G-ABG-PG9	Cable socket, M12, 5-pin, shielded, non pre-wired
V15SB-G-ABG-PG9	Cable connector, M12, for PROFIBUS, adjustable
ICZ-3T-0,3M-PUR ABG-V15B-G	Y-splitter connector for PROFIBUS
ICZ-TR-V15B	Terminal resistor for PROFIBUS
ICZ-2T/TR-0,2M-PUR ABG-V15B-G	Terminal cable for PROFIBUS with terminal resistor
VAZ-PB-DB9-W	PROFIBUS Sub-D Data connector with switchable terminal resistance
IVZ-K-R2	Null modem cable
ICZ-AIDA1-V45	Field connector for RJ-45
CBL-PUR-PN-GN-04x034-100M	Data connector, PROFINET, PUR/PE, 4-pin, shielded



Properties

- Ethernet/IP, PROFIBUS, various Ethernet protocols, CC-Link and serial interface versions
- Versions with 1 and 2 connectable R/W heads

Benefits

- All IDENT Control interfaces support all IPH and IQH R/W heads
- Metal housing and continuous shielding concept result in exceptional noise resistance
- Common user interface makes application development for different PLCs simpler and faster
- Quick disconnect design speeds up installation and eliminates wiring errors
- Second port, if present, can be used as a trigger sensor input

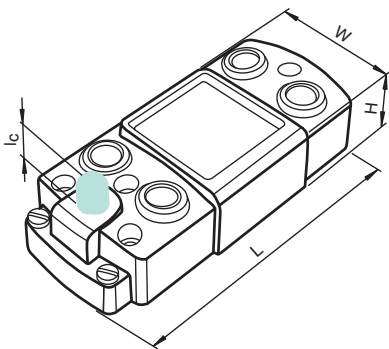

Technical Data

For detailed data and product description refer to the data sheets at www.pepperl-fuchs.us

General Data

UL File Number	E87056
LED PWR/ERR	Power on
Rated operational voltage	20 ... 30 V DC , PELV
Ambient temperature	-25 ... 70 °C (-13 ... 158 °F)
Protection degree	IP67
Housing material	Powder coated zinc
Installation	screw fixing

Model Number

		IC-KP2-1HB17-2V1D	IC-KP2-1HB6-V15B	IC-KP2-1HRX-2V1	IC-KP2-2HB17-2V1D	IC-KP2-2HB18-2V1	IC-KP2-2HB6-V15B	IC-KP2-2HRX-2V1	IC-KP2-2HB21-2V1D
Number of read/write heads	max. 1	●	●	●					
	max. 2								
	alternatively 1 read/write head and 1 trigger sensor				●	●	●	●	●
LEDs 1, 2	Status indicator for read/write heads				●	●	●	●	●
LED 1	Status indicator for read/write head	●	●	●					
LEDs CH1, CH2	Read head detected				●	●	●	●	●
LED CH1	Read head detected	●	●	●					
LED BUS	Data exchange		●				●		
LED Diag	Receiving data		●				●		
LED Link/Traffic	Network connection	●			●				
LED L RUN	Data communication active					●			
LED L ERR	Invalid rotary switch setting or data transfer failure					●			
LED TxD	Transmitting data			●				●	
LED RxD	Receiving data			●				●	
Rotary switch	Address setting	●	●		●	●	●	●	
Current consumption	≤ 2 A incl. read/write head	●	●	●			●	●	
	≤ 4 A incl. read/write heads				●	●			●
Interface:									
Protocol	ASCII, RS 232			●				●	
	CC-Link								
	PROFIBUS DP		●				●		
	MODBUS/TCP / TCP/IP				●				
	EtherNet/IP / PROFINET IO	●							
	EtherCAT								●
Diagnostic interface:									
Protocol	ASCII		●			●	●		●

Dimensions

Length L [mm]	136.6	141.6	136.6	141.6
Width W [mm]		61.4		
Height H [mm]		33		
Connector area lc [mm]		9		

Accessories

These and more accessories can be found in chapter 10

See pages from 970 ... for cordsets See pages 1066 ... for mounting accessories

V1S-G-0,15M-PUR-ABG-SUBD	Adapter M12 on Sub-D for PC connection with null modem cable
V1-G-*M-PUR-ABG-V1-W	Double-ended cordset, M12 to M12, PUR cable 4-pin, shielded
ICZ-MH05-SACB-8	Mounting aid for DIN rail
V1SD-G-5M-PUR-ABG-V45-G	Double-ended cordset, M12 to RJ-45, PUR cable 4-pin, CAT5e
ICZ-3T-0,2M-PUR ABG-V15B-G	Y-splitter cordset for PROFIBUS
ICZ-2T/TR-0,2M-PUR ABG-V15B-G	Terminal cable for PROFIBUS with terminal resistor
V15B-G-*M-PUR-ABG-V15B-G	Data connector PROFIBUS, M12 to M12, PUR cable
V1-G-ABG-PG9	Field connector, M12, 4-pin, screened, ready to make up
V1S-G-ABG-PG9	4-pin, M12, screened field connector
ICZ-3T-0,3M-PVC-CCL-V1-G	Y-splitter cordset for CC-Link
V3S-GM-0,15M-PUR-ABG-SUBD	Adapter M8 on Sub-D for PC connection with null modem cable
ICZ-TR-V1-130R	Terminal resistor for CC-Link, 130 ohm
ICZ-TR-V1-110R	Terminal resistor for CC-Link, 110 ohm



Properties

- Up to 65 mm range
- LF and HF System
- ø 18 and 30 mm versions, cylindrical

Benefits

- Compatibility with any IDENTControl interface simplifies parts selection and reduces complexity

IPH-*

- LF solutions for high metallic environments

IQH1-*

- HF solution enables fast data exchange
- Conforms to ISO/IEC 15693
- Use with IQC tag

IQH2-*

- Conforms to ISO/IEC 14443 Mode A
- Exceptionally fast tag access, ideal for high-speed applications

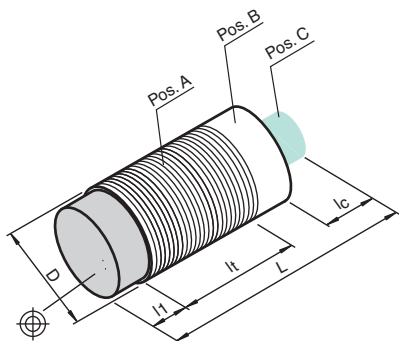

Technical Data

For detailed data and product description refer to the data sheets at www.pepperl-fuchs.us

General Data

UL File Number	E87056
LED green/yellow	Multihole-LED: green: power on green flashing: read/write attempt performed yellow: data carrier detected
Power consumption	≤ 1.2 W
Ambient temperature	-25 ... 70 °C (-13 ... 158 °F)
Protection degree	IP67
Connection	M12 x 1 connector
Installation	non-flush

Model Number

		IPH-18GM-V1	IQH1-18GM-V1	IQH2-18GM-V1	IPH-30GM-V1
Operating frequency	125 kHz	●			●
	13.56 MHz		●	●	
Read distance	0 ... 22 mm			●	
	0 ... 55 mm		●		
	1 ... 50 mm	●			
Write distance	1 ... 65 mm				●
	0 ... 22 mm			●	
	0 ... 40 mm	●			
	0 ... 55 mm		●		
	1 ... 55 mm				●

Dimensions

Length L [mm]	66	
Diameter D [mm]	18	30
Thread length l ₁ [mm]	34	32
Cap length l ₂ [mm]	16	18
Connector area l _c [mm]	16	

Accessories

These and more accessories can be found in chapter 10

See pages from 970 ... for cordsets See pages 1066 ... for mounting accessories

V1-G-*M-PUR-ABG-V1-W

Double-ended cordset, M12 to M12, PUR cable 4-pin, shielded



Technical Data

For detailed data and product description refer to the data sheets at www.pepperl-fuchs.us

General Data

UL File Number	E87056
Power consumption	≤ 1.8 W
Type of protection	II 2G EEx d IIC T6/T5
	II 2D EEx tD A21 IP68 T80°C/95°C
ATEX Directive 94/9/EC	EN 60079-0:2006, EN 60079-1:2004, EN 61241-0:2006, EN 61241-1:2004
Ambient temperature	-20 ... 50 °C (-4 ... 122 °F)
Protection degree	IP68
Installation	flush

Model Number

IQH1-30GM105-EXD dS64M-1038

IPH-30GM105-EXD dS64M-1038

Operating frequency	125 kHz		
	13.56 MHz	●	●
Operating distance	0 ... 9 mm	●	
	0 ... 10 mm		●

Properties

- LF and HF System versions
- ø 30 mm, cylindrical
- Suitable for hazardous areas

Benefits

- RFID head for hazardous area applications
- Compatibility with any IDENTControl interface simplifies parts selection and reduces complexity

IQH*-*

- HF solution enables fast data exchange
- Conforms to ISO/IEC 15693
- Use with IQC tag

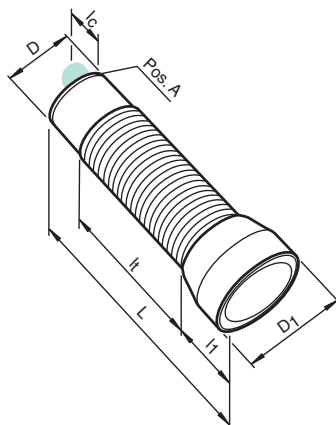

Dimensions

Length L [mm]	105
Diameter D [mm]	30
Cap diameter D ₁ [mm]	38
Cap length L ₁ [mm]	38



Technical Data

For detailed data and product description refer to the data sheets at www.pepperl-fuchs.us

General Data

Operating frequency	125 kHz
UL File Number	E87056
Power consumption	≤ 1.2 W

Model Number

		IPH-F15-V1	IPH-F61-V1	IPH-F90A-V1	IPH-F97-V1	IPH-FP7V4A	IPH-FP-V1	IPH-L2-V1
Read distance	0 ... 100 mm					●	●	
	1 ... 70 mm (with transponder IPC03-50P)				●			
	1 ... 75 mm							●
	2 ... 155 mm	●						
Write distance	2 ... 45 mm		●					
	3 ... 90 mm (with transponder IPC03-50P)			●				
	0 ... 80 mm					●	●	
	1 ... 58 mm (with transponder IPC03-50P)				●			
Ambient temperature	2 ... 140 mm	●						
	2 ... 35 mm		●					
	2 ... 65 mm							●
	3 ... 80 mm (with transponder IPC03-50P)			●				
Protection degree	-25 ... 55 °C (-13 ... 131 °F)	●	●	●	●	●	●	●
	-25 ... 70 °C (-13 ... 158 °F)	●	●	●	●	●	●	●
Installation	IP67	●	●	●	●	●	●	●
	IP69K					●		
Installation	non-flush in metal							●

Properties

- Up to 155 mm range
- LF System
- Various housing styles

Benefits

- LF solutions for high metallic environments
- Compatibility with any IDENT Control interface simplifies parts selection and reduces complexity

IPH-F90A-V1

- Long housing design offers lateral tolerance of reading position

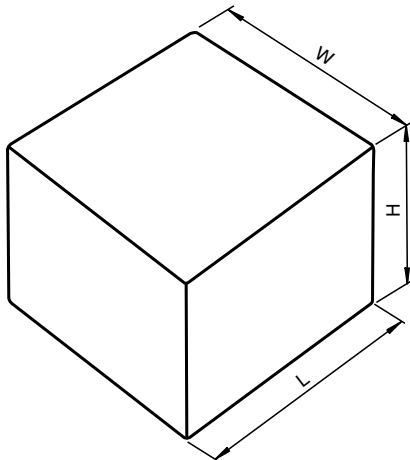

Dimensions

Length L [mm]	190	80	144.5	540	103	113	55.5
Width W [mm]	140	28	43.5	50	80	80	40
Height H [mm]	40.5	12	21	34	42	40	40

Accessories

These and more accessories can be found in chapter 10

See pages from 970 ... for cordsets See pages 1066 ... for mounting accessories

V1-G-*M-PUR-ABG-V1-W	Double-ended cordset, M12 to M12, PUR cable 4-pin, shielded
----------------------	---

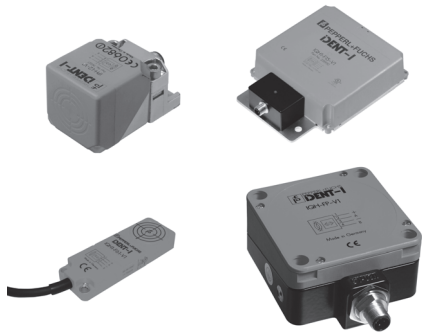

Properties

- Up to 160 mm range
- HF System
- Various housing styles

Benefits

IQH1-*

- HF solution enables fast data exchange
- Conforms to ISO/IEC 15693
- Use with IQC tag

IQH2-*

- Conforms to ISO/IEC 14443 Mode A
- Exceptionally fast tag access, ideal for high-speed applications

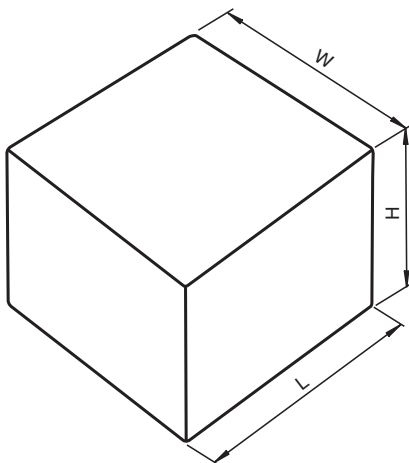

Technical Data

For detailed data and product description refer to the data sheets at www.pepperl-fuchs.us

General Data

Operating frequency	13.56 MHz
UL File Number	E87056
Protection degree	IP67

Model Number

	IQH1-FP-V1	IQH2-FP-V1	IQH1-F15-V1	IQH1-F61-V1	IQH2-F61-V1	IQH2-L2-V1
Read distance	0 ... 35 mm (with transponder IQC42-C1)				●	
	0 ... 40 mm (with transponder IQC42-C1)					●
	0 ... 50 mm	●				
	0 ... 130 mm	●		●		
Write distance	0 ... 160 mm (with transponder IQC22-C4)		●			
	0 ... 35 mm (with transponder IQC42-C1)				●	
	0 ... 40 mm (with transponder IQC42-C1)					●
	0 ... 50 mm		●			
Power consumption	0 ... 130 mm	●		●		
	0 ... 160 mm (with transponder IQC22-C4)			●		
	≤ 1.3 W	●	●	●	●	●
Ambient temperature	≤ 3.5 W					
	-25 ... 70 °C (-13 ... 158 °F)	●	●	●	●	●
	-5 ... 70 °C (23 ... 158 °F)		●			

Dimensions

Length L [mm]	108.5	190	80	55.5
Width W [mm]	80	140	28	40
Height H [mm]	40	40.5	12	40

Accessories

These and more accessories can be found in chapter 10

See pages from 970 ... for cordsets See pages 1066 ... for mounting accessories

V1-G-*M-PUR-ABG-V1-W

Double-ended cordset, M12 to M12, PUR cable 4-pin, shielded

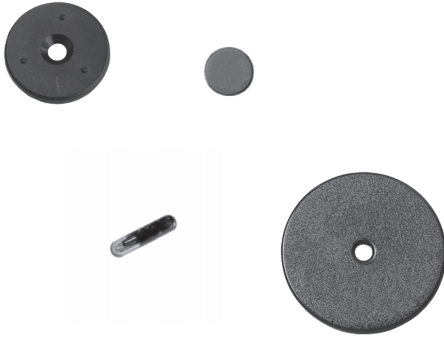

Properties

- Diameter 12.4 - 50mm
- Height 2.2 - 3 mm
- LF System
- Read only tags

Benefits

- Battery-free construction results in unlimited lifetime
- Chemically resilient encapsulation housing for harsh environments
- Extended temperature range for paint and curing applications
- Usable with any IPH R/W head

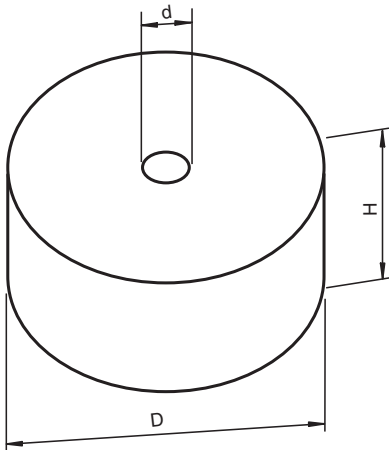

Technical Data

For detailed data and product description refer to the data sheets at www.pepperl-fuchs.us

General Data

Operating frequency	125 kHz
Transfer rate	2 kBit/s
Memory	
Chip type	EM4102 Unique (EM Microelectronic)
Type/Size	ROM 64 Bit (40 Bit code, 24 bit data security)
Read cycles	unlimited

Model Number

	IPC02-12	IPC02-16	IPC02-20P	IPC02-26-T6	IPC02-30P	IPC02-50P	IPC02-3GL
Ambient temperature							
-20 ... 100 °C (-4 ... 212 °F)							
-20 ... 85 °C (-4 ... 185 °F)							
-25 ... 85 °C (-13 ... 185 °F)	●	●	●				
-25 ... 85 °C (-13 ... 185 °F)							
20 ... 160 °C (68 ... 320 °F) for 100 x 5 minutes with transposition every 30 seconds				●			
-40 ... 85 °C (-40 ... 185 °F)							
Protection degree							
IP68	●	●		●	●	●	●
IP68 / IP69K			●				
Material							
Housing							
Epoxy (black)	●	●					
PC (Polycarbonate)			●		●	●	
PA				●			
glass							●

Dimensions

Height H [mm]	2.2	3	4	3	13		
Diameter D [mm]	12.4	16	20	26	30	50	3.15
Middle hole d [mm]		-		4.5	3	5	-

Accessories

These and more accessories can be found in chapter 10

See pages from 970 ... for cordsets See pages 1066 ... for mounting accessories

IPZ-MH50	Spacer
----------	--------



Properties

- Diameter 12.4 - 58mm
- Height 3 - 20.1 mm
- LF System
- Programmable tags

Benefits

- Battery-free for an unlimited lifetime
- Chemically resilient encapsulation housing for harsh environments
- Flush mounting in metal for increased mechanical protection (for some versions - as indicated)
- Usable with any IPH R/W head

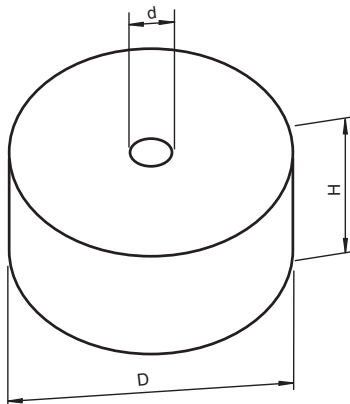

Technical Data

For detailed data and product description refer to the data sheets at www.pepperl-fuchs.us

General Data

Operating frequency	125 kHz
Transfer rate	2 kBit/s
Memory	
Chip type	EM4450 Titan (EM Microelectronic)
Type/Size	EEPROM 928 Bit ROM 32 Bit
Read cycles	unlimited
Write cycles	> 100 000

Model Number

	IPC03-12.4	IPC03-16GK	IPC03-20P	IPC03-24	IPC03-30P	IPC03-30GK	IPC03-50P	IPC03-58
Ambient temperature	-20 ... 100 °C (-4 ... 212 °F)	-20 ... 85 °C (-4 ... 185 °F)	-25 ... 70 °C (-13 ... 158 °F)	-25 ... 85 °C (-13 ... 185 °F)				
Protection degree	IP67	IP68	IP68 / IP69K					
Flush mountable								
Material								
Housing	PBT	PC (Polycarbonate)	PP	PA 6 (Polyamid)				

Dimensions

Height H [mm]	6	3	11	3	20	5	20.1
Diameter D [mm]	12.3	16	20	24	30	50	58
Middle hole d [mm]		-			3	-	5

Accessories

These and more accessories can be found in chapter 10

See pages from 970 ... for cordsets See pages 1066 ... for mounting accessories

IVZ-16G-EW	Screw-in tool
IVZ-30G-EW	Screw-in tool
IPZ-MH50	Spacer

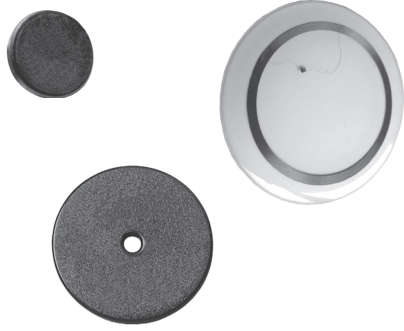

Technical Data

For detailed data and product description refer to the data sheets at www.pepperl-fuchs.us

General Data

Operating frequency	125 kHz
Transfer rate	2 kBit/s
Memory	
Chip type	Q5
Type/Size	EEPROM Bit 40 bit fixcode free programmable
Read cycles	unlimited

Model Number

		IPC11-12	IPC11-30	IPC11-50
Ambient temperature	-25 ... 70 °C (-13 ... 158 °F) -25 ... 85 °C (-13 ... 185 °F)	●	●	●
Protection degree	IP67 IP68	●	●	●
Material				
Housing	PPS and epoxy (black) PC (Polycarbonate) ROYALPLAST, transparent, soft	●	●	●

Properties

- Diameter 12.4 - 50 mm
Height 2 mm
- LF System
- Programmable tags

Benefits

- Battery-free for an unlimited lifetime
- Chemically resilient encapsulation housing for harsh environments
- Write-once-read-many tag allows for custom codes
- Usable with any IPH R/W head

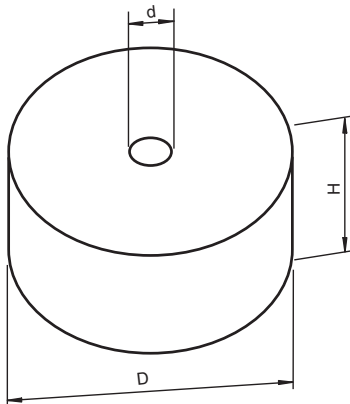

Dimensions

	12.4	30	50
Height H [mm]	2	2	1.5
Diameter D [mm]	12.4	30	50
Middle hole d [mm]	-	3	-

Accessories

These and more accessories can be found in chapter 10

IPZ-MH50	Spacer
----------	--------

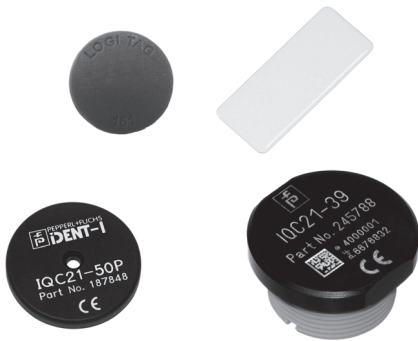

Properties

- Rectangular version: 65 x 25 x 3 mm
- Cylindrical versions:
Diameter 12.4 - 50mm
Height 2 mm
- HF System
- Programmable tags

Benefits

- Battery-free for an unlimited lifetime
- Usable with any IQH1 R/W head

IQC21-85-T13 & IQC22-22-T9

- High-temperature design for paint and curing applications

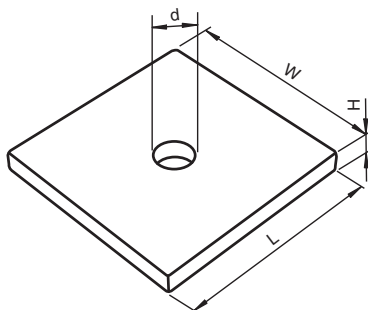
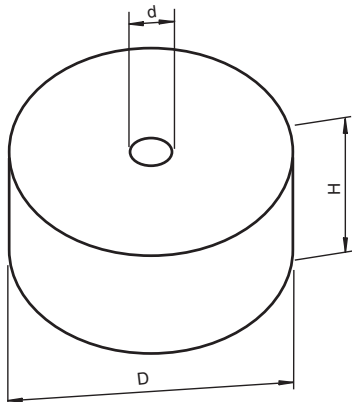

Technical Data

For detailed data and product description refer to the data sheets at www.pepperl-fuchs.us

General Data

Operating frequency	13.56 MHz
Transfer rate	26 kBit/s
Read cycles	unlimited

Model Number

Memory						
Chip type	I-CODE SLI (NXP)					
	Tag-it HF-I Plus (Texas Instruments)					
Type/Size	EEPROM 896 Bit					
	ROM 64 Bit					
	EEPROM 2 kBit					
	ROM 64 Bit					
Ambient temperature	-25 ... 50 °C (-13 ... 122 °F)					
	-25 ... 70 °C (-13 ... 158 °F)					
	-25 ... 100 °C (-13 ... 212 °F)					
	140 °C (413 K) for 20% reduction in limit of exposure zone					
	200 °C (473 K) for 4000 hours or 1500 cycles					
	220 °C (493 K) for 2000 hours or 500 cycles					
	-25 ... 85 °C (-13 ... 185 °F)					
	-25 ... 90 °C (-13 ... 194 °F)					
	-40 ... 150 °C (-40 ... 302 °F)					
Protection degree	IP65					
	IP67					
	IP68					
Material						
Housing	PPS					
	PC (Polycarbonate)					
	ABS					
	PA/POM					
	PP/POM					

	IQC21-50P	IQC21-58	IQC21-85-T13	IQC21-F125	IQC22-22-T9	IQC21-39	IQC21-39-T1
Chip type	●	●	●	●	●	●	●
EEPROM 896 Bit	●	●	●	●	●	●	●
EEPROM 2 kBit	●	●	●	●	●	●	●
140 °C (413 K) for 20% reduction in limit of exposure zone	●	●	●	●	●	●	●
200 °C (473 K) for 4000 hours or 1500 cycles	●	●	●	●	●	●	●
220 °C (493 K) for 2000 hours or 500 cycles	●	●	●	●	●	●	●
IP65	●	●	●	●	●	●	●
IP67	●	●	●	●	●	●	●
IP68	●	●	●	●	●	●	●
PPS	●	●	●	●	●	●	●
PC (Polycarbonate)	●	●	●	●	●	●	●
ABS	●	●	●	●	●	●	●
PA/POM	●	●	●	●	●	●	●
PP/POM	●	●	●	●	●	●	●

Dimensions

Length L [mm]				65		
Width W [mm]				25		
Height H [mm]	5	20.1	21.5	3	3	21.5
Diameter D [mm]	50	58	39		22	39
Middle hole d [mm]	5	6.5	-		-	-

Accessories

These and more accessories can be found in chapter 10
See pages from 970 ... for cordsets See pages 1066 ... for mounting accessories

IPZ-MH50	Spacer
----------	--------

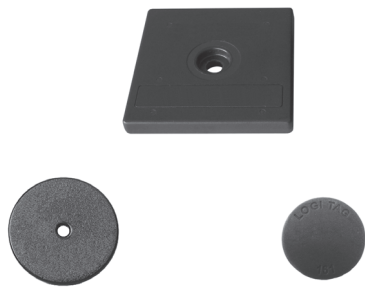

Properties

- Square versions: 51 x 51 x 6.5 mm
Cylindrical versions:
Diameter 16 and 30mm
Height 2.9 - 3 mm
- HF System
- Programmable tags

Benefits

- HF tags enables fast data exchange
- Conforms to ISO 15693
- Use with any IQH1 R/W head

IQC21-50F-T10

- High-temperature design for paint and curing applications

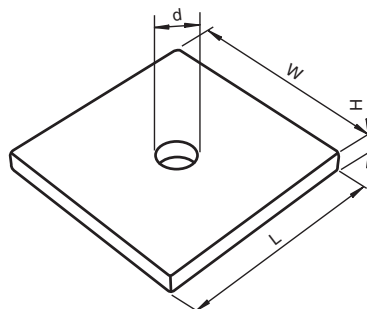
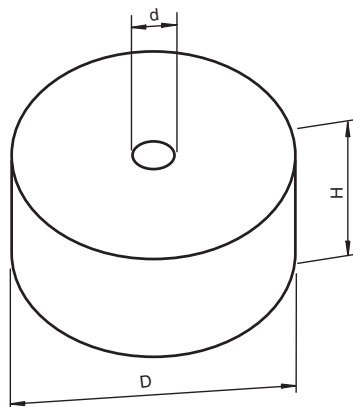

Technical Data

For detailed data and product description refer to the data sheets at www.pepperl-fuchs.us

General Data

Operating frequency	13.56 MHz
Memory	
Type/Size	EEPROM 896 Bit ROM 64 Bit
Transfer rate	26 kBit/s
Memory	
Chip type	I-CODE SLI (NXP)
Read cycles	unlimited

Model Number

		IQC21-16	IQC21-30P	IQC21-50F-T10
Ambient temperature	-40 ... 93 °C (-40 ... 199.4 °F)			●
	-20 ... 100 °C (-4 ... 212 °F)		●	
	-25 ... 70 °C (-13 ... 158 °F) 120 °C for 100 h 220 °C for 30 s	●		
Protection degree	IP67	●		
	IP68		●	●
Material				
Housing	PPS			●
	PC (Polycarbonate)	●	●	

Dimensions

Length L [mm]				51
Width W [mm]				51
Height H [mm]	2.9	3		6.5
Diameter D [mm]	16	30		
Middle hole d [mm]		3		5.5

Accessories

These and more accessories can be found in chapter 10

See pages from 970 ... for cordsets See pages 1066 ... for mounting accessories

ICZ-MH30-25-T10	Spacers for code/data carrier
IQZ-MH-85	Spacers for code/data carrier

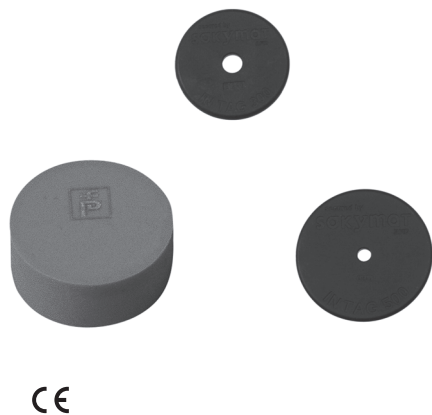

Properties

- Diameter 10 - 50mm
- Height 2 - 4.5 mm
- HF System
- Programmable tags

Benefits

- Conforms to ISO/IEC 15693
- FRAM technology allows unlimited number of R/W operations
- Large data capacity holds application specific data
- Usable with any IQH1 R/W head

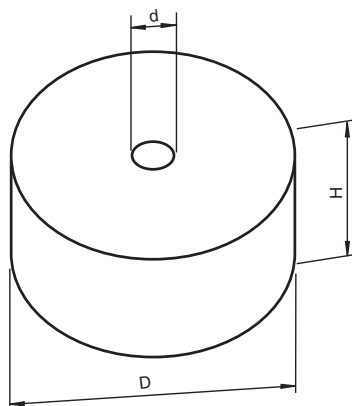

Technical Data

For detailed data and product description refer to the data sheets at www.pepperl-fuchs.us

General Data

Operating frequency	13.56 MHz
Transfer rate	26 kBit/s
Memory	
Read cycles	unlimited

Model Number

		IQC33-10	IQC33-16	IQC33-20	IQC33-30	IQC33-50	IQC35-10
Memory							
Chip type	FRAM MB89R118 (Fujitsu)	●	●	●	●	●	
Type/Size	ICODE SLI-S (NXP)						●
	FRAM 16 kBit , fixcode 64 Bit	●	●	●	●	●	
	EEPROM 2048 Bit , fixcode 64 Bit						●
Write cycles	unlimited	●	●	●	●	●	
	> 100000						●
Ambient temperature	-20 ... 85 °C (-4 ... 185 °F)		●	●	●	●	
	-25 ... 85 °C (-13 ... 185 °F)						●
	-40 ... 85 °C (-40 ... 185 °F)	●					
Protection degree	IP67	●	●				
	IP68			●	●	●	●
Material							
Housing	PBT	●					
	Polycarbonate		●				
	PA 6 modified			●	●	●	
	PPS						●

Dimensions

Height H [mm]	4.5	3	2.8	2.8	3.3	2
Diameter D [mm]	10	16	20	30	50	10
Middle hole d [mm]	-	-	-	5.2	-	-



CE

Technical Data

For detailed data and product description refer to the data sheets at www.pepperl-fuchs.us

Model Number	IQC43-30 IQC43-50
Operating frequency	13.56 MHz
Transfer rate	106 kBit/s
Memory	
Chip type	NXP MF1 S7009
Type/Size	EEPROM 4096 Byte 3440 Byte User data
Read cycles	unlimited
Write cycles	> 100 000
Ambient temperature	-40 ... 85 °C (-40 ... 185 °F)
Protection degree	IP68
Material	
Housing	Thermoplastic polyester

Properties

- Diameter 30 - 50mm
Height 3 mm
- HF System
- Programmable tags

Benefits

- Conforms to ISO/IEC 14443
- Large data capacity holds application specific data

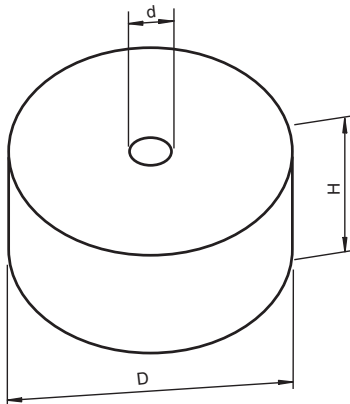

Dimensions	IQC43-30	IQC43-50
Height H [mm]	3	3
Diameter D [mm]	30	50
Middle hole d [mm]	3	5

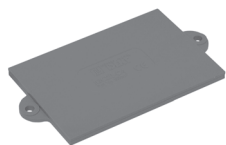

Properties

- Length 85.6 and 116 mm
Width 54 and 64.5 mm
Height 0.8 and 5 mm
- LF and HF System
- Programmable and read only tags

Benefits

- Battery-free for an unlimited lifetime
- Card format ideal for machine access control

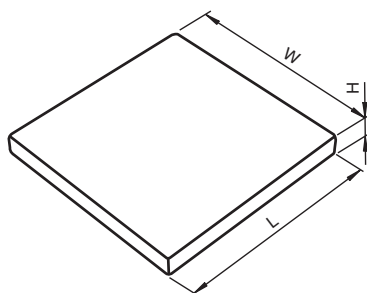

Technical Data

For detailed data and product description refer to the data sheets at www.pepperl-fuchs.us

General Data

Memory	
Read cycles	unlimited

Model Number

		IPC02-C1	IPC03-C1	IOC22-C1	IOC24-C1	IOC42-C1	IOC22-C4
Operating frequency	125 kHz	●	●				
	13.56 MHz (according to ISO/IEC 15693)			●	●		●
	13.56 MHz (according to ISO/IEC 14443)					●	
Transfer rate	2 kBit/s	● ⁹	●				
	26 kBit/s			●	●		●
	106 kBit/s					●	
Memory	Chip type						
	EM4102 Unique (EM Microelectronic)	●					
	EM4450 Titan (EM Microelectronic)		●				
	Tag-it HF-I Plus (Texas Instruments)			●			●
Type/Size	NXP MF1 S5009					●	
	EEPROM 2 kBit						
	ROM 64 Bit			●			●
	EEPROM 1024 Byte						
	ROM 56 Bit 752 Byte User data					●	
	EEPROM 928 Bit						
	ROM 32 Bit		●				
Ambient temperature	EEPROM 992 Byte				●		
	ROM 64 Bit						
	ROM 64 Bit	●					
	(40 Bit code, 24 bit data security)						
Protection degree	0 ... 50 °C (32 ... 122 °F)	●	●				
	0 ... 55 °C (32 ... 131 °F)			●	●		
	-20 ... 50 °C (-4 ... 122 °F)					●	
Material	-25 ... 70 °C (-13 ... 158 °F)						●
	IP20						
Housing	IP67	●	●	●	●	●	●
	PVC	●	●	●	●	●	
	ABS						●

Dimensions

Length L [mm]	85.6	116
Width W [mm]	54	64.5
Height H [mm]	0.8	5

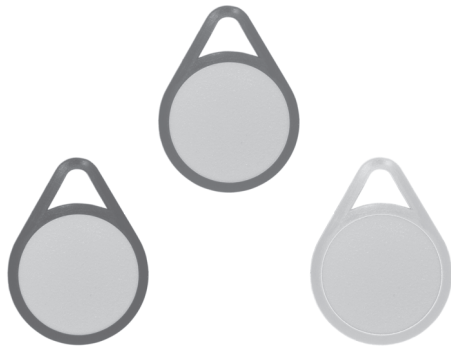

Properties

- Keyrings
40 x 31 mm and
46.5 x 35 mm
- LF System
- Programmable tags

Benefits

- Battery-free for an unlimited lifetime
- Chemically resilient encapsulation housing for harsh environments
- Keyring design is ideal for machine and building access control systems

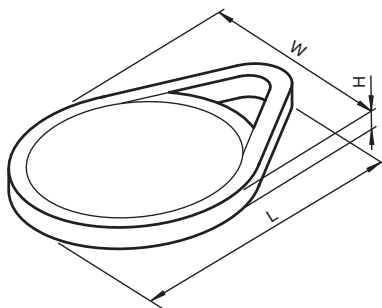

Technical Data

For detailed data and product description refer to the data sheets at www.pepperl-fuchs.us

General Data

Operating frequency	125 kHz
Transfer rate	2 kBit/s
Memory	
Chip type	EM4450 Titan (EM Microelectronic)
Type/Size	EEPROM 928 Bit ROM 32 Bit
Read cycles	unlimited
Protection degree	IP67
Material	
Housing	PC (Polycarbonat)

Model Number

	IPC03-20K1	IPC03-20K2	IPC03-20K3	IPC03-20K4	IPC03-20K5	IPC03-20K6
Color	black					
	red					
	white					
	blue					
	green					
Ambient temperature	-20 ... 80 °C (-4 ... 176 °F)					
	-25 ... 70 °C (-13 ... 158 °F)					

Dimensions

Length L [mm]	40	46.5
Width W [mm]	31	35
Height H [mm]	4.5	5

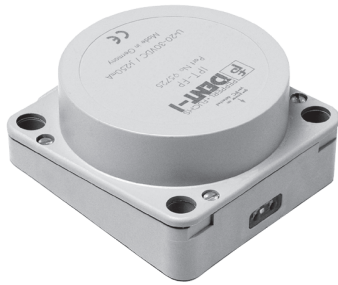

Benefits

- Single R/W station with direct field-bus connection by combining this head unit with the preferred U-P* base unit

Technical Data

For detailed data and product description refer to the data sheets at www.pepperl-fuchs.us

Model Number	IPT1-FP
Operating frequency	125 kHz
UL File Number	E87056
Power consumption	max. 5 W , in connection with the base
Physical	Interface type depends on base used
Ambient temperature	-25 ... 70 °C (-13 ... 158 °F)
Protection degree	IP67 according to EN 60529, with base

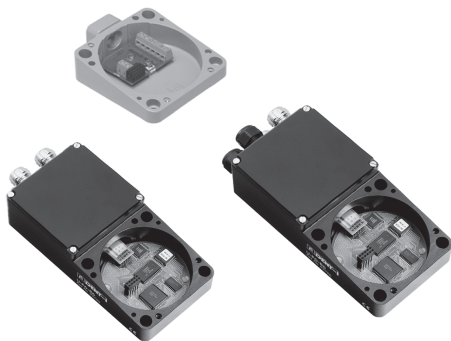

General Data

Ambient temperature	-25 ... 70 °C (-13 ... 158 °F)
Protection degree	IP67 according to EN 60529 with IPT*-FP

Model Number

	U-P3-R4	U-P3-R4-V15	U-P3-RX	U-P3V4A-RX	U-P4-R4	U-P4-RX	U-P6-B5	U-P6-B5-V	U-P6-B6	U-P6-B6-V15B	U-P6V4A-B6	U-P7V4A-R4
Power consumption	max. 4 W with read/write head IPT*-FP	max. 5 W with read/write head IPT*-FP										
Physical	RS 232/RS 485	RS 485										
Protocol	RS 485, addressable , up to 30 bases , address 1 ... 30	ASCII	INTERBUS remote bus	PROFIBUS DP acc. to EN 50170								

Properties

- PROFIBUS, INTERBUS and serial versions
- Flat packed housing
- Use any IPC* tag

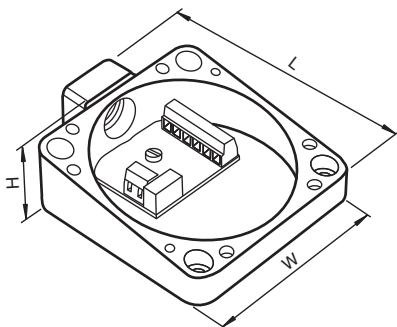

Dimensions

Length L [mm]	92 114	92	162	103
Width W [mm]		80		
Height H [mm]		30	50	30
Assembled height H [mm] with IPT1-FP		64	79	64

Accessories

These and more accessories can be found in chapter 10
See pages from 970 ... for cordsets See pages 1066 ... for mounting access

ICZ-3T-0,3M-PUR ABG-V15B-G	Y connection cable for PROFIBUS
ICZ-TR-V15B	Terminal resistor for PROFIBUS
V15B-G-ABG-PG9	Cable socket, M12, 5-pin, shielded, non pre-wired
V15SB-G-ABG-PG9	Cable connector, M12, for PROFIBUS, adjustable
V15B-G-*M-PUR ABG-V15B-G	M12 connection cable for PROFIBUS

Refer to General Notes Relating to Product Information

Pepperl+Fuchs Group
www.pepperl-fuchs.com

USA: +1 330 486 0001
fa-info@us.pepperl-fuchs.com

Germany: +49 621 776-4411
fa-info@de.pepperl-fuchs.com

Singapore: +65 6779 9091
fa-info@sg.pepperl-fuchs.com

Copyright Pepperl+Fuchs





Properties

- Up to 6 m read range
- Integrated serial and Ethernet communication

Benefits

- Stand,alone reader for simple integration
- Fast moving objects are securely tracked
- Reader can be controlled via commands and digital I/O
- Multi-tag reading allows several objects to be detected at the same time

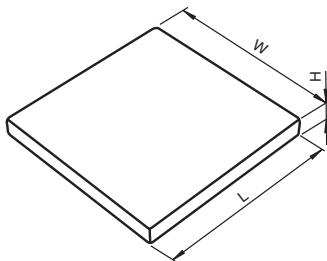

Properties

- Tags available for industrial, harsh application
- Read only and read / write tags available
- Mountable directly onto metal

Benefits

- Predictable battery life allows cost/benefit calculations
- Ideal for rack and container tracking due to flexible tag mounting and multi-tag reading

Technical Data

For detailed data and product description refer to the data sheets at www.pepperl-fuchs.us

General Data

Memory	
Type/Size	Flash 16 MByte RAM 32 MByte
Interface	
	Ethernet / RS 232/RS 485
Memory	
Type/Size	Flash 16 MByte RAM 32 MByte
Ambient temperature	
	-20 ... 60 °C (-4 ... 140 °F)
Protection degree	
	IP65
Material	
Housing	Plastic

		MTT3000-F180-B12-V45-MON	MTT6000-F120-B12-V45
Operating frequency	2.402 ... 2.482 GHz		
	2.402 ... 2.482 GHz Frequency Hopping (FHSS) 2.400 ... 2.484 GHz	●	●
Operating distance	max. 3 m	●	
	max. 6 m		●
Transfer rate	read: 4 kBit/s , 16 kBit/s		●
	write: 4 kBit/s 16 kBit/s	●	

Model Numbers of Tags

		MTO-C1	MTO-C2	MTM-C1	MTM-C2
Memory					
Capacity	an 8-digit decimal number as fixcode and 32-bit checksum	●	●		
	606 Bit R/W (584 bits available for user data) 8-digit decimal number as fixcode			●	●
Battery life		●	●	●	●
Ambient temperature		●	●	●	●
	-20 ... 85 °C (-4 ... 185 °F)				
	-40 ... 85 °C (-40 ... 185 °F)	●	●	●	●
Protection degree		●	●	●	●
Material					
Housing		●	●	●	●
	Polymer				

Dimensions

	MTO-C1	MTO-C2	MTM-C1	MTM-C2
Length L [mm]	86	90	86	90
Width W [mm]	54	58	54	58
Height H [mm]	3	8	3	8

Accessories

These and more accessories can be found in chapter 10

See pages from 970 ... for cordsets See pages 1066 ... for mounting accessories

MTA-C1V1	Card holder with fixing clip
MTA-C1V2	Card holder for window mounting in vehicles
MTA-MH09	Mounting bracket for pole and wall mounting



Properties

- LF and HF System

Benefits

- Flexible handheld solution for any R/W head
- Battery powered Bluetooth handheld for true mobile RFID applications
- Display and keypad allows even complex user interaction
- Users can develop in-house applications using JavaScript

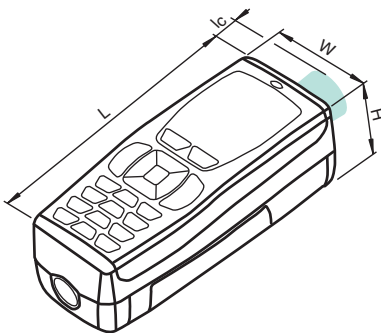

Technical Data

For detailed data and product description refer to the data sheets at www.pepperl-fuchs.us

General Data

UL File Number	E87056
Display	128 x 128 pixel monochrome LC Display
Keyboard	Keypad for entering alphanumerical characters
Key	Programmable function keys
Supply	from interface or Li-Ion battery
Physical	Bluetooth , USB 2.0 , RS 232 or PS/2
Protocol	ASCII
Ambient temperature	0 ... 40 °C (32 ... 104 °F)
Protection degree	IP20

Model Number

		IC-HH20-V1	IPT-HH20	IQT1-HH20
Operating frequency	125 kHz		●	
	13.56 MHz			●
	acc. to connected read/write head	●		●

Dimensions

Length L [mm]	111
Width W [mm]	46
Height H [mm]	41
Connector area l _c [mm]	11

Accessories

These and more accessories can be found in chapter 10

See pages from 970 ... for cordsets See pages 1066 ... for mounting accessories

ODZ-MAH-CHARGER-5310	Charging tray for ODZ-MAH-GRIP2/GRIP3
V1-G-0,5/2,5M-PUR-V1-G	Double-ended cordset, Helix cable
ODZ-MAH-SUPPLY	Power supply
ODZ-MAH-BLANK	Battery blank
ODZ-MAH-GRIP1	Handle with trigger button
ODZ-MAH-GRIP2	Handle with trigger button and 1950 mAh battery
ODZ-MAH-GRIP3	Handle with trigger button and 3900 mAh battery
ODZ-MAH-CAB-CHARGE	Cable for power supply unit
ODZ-MAH200-CHARGER	Charger for ODT-HH-MAH200/ODZ-MAH-BAT
ODZ-MAH-CHARGER	Charging tray for ODZ-MAH-GRIP2/GRIP3
ODZ-MAH-CAB-B14	Double-ended cordset with USB Interface
ODZ-MAH-CAB-R6	Double-ended cordset PS/2 interface
ODZ-MAH-CAB-R2	Double-ended cordset RS 232 interface
ODZ-MAH-CHARGER-SINGLE	Charger for ODT-HH-MAH200/300/I* T-HH20
ODZ-MAH-B15-M3	Bluetooth modem, configured for USB
ODZ-MAH-5V-110V	Power supply
ODZ-MAH-CHARGER-UM-110V	Charging tray for ODZ-MAH-GRIP2/GRIP3