

Air Slide Table

ø12, ø16

New

RoHS

Compact, Lightweight

Height **18 mm** Width **34 mm**

Weight **267 g**

* MXJ, ø12, 30 mm stroke

High Precision

High-precision linear guide mounted

Traveling parallelism **0.005 mm**

Mounting parallelism

0.03 mm

Side mounting and piping possible

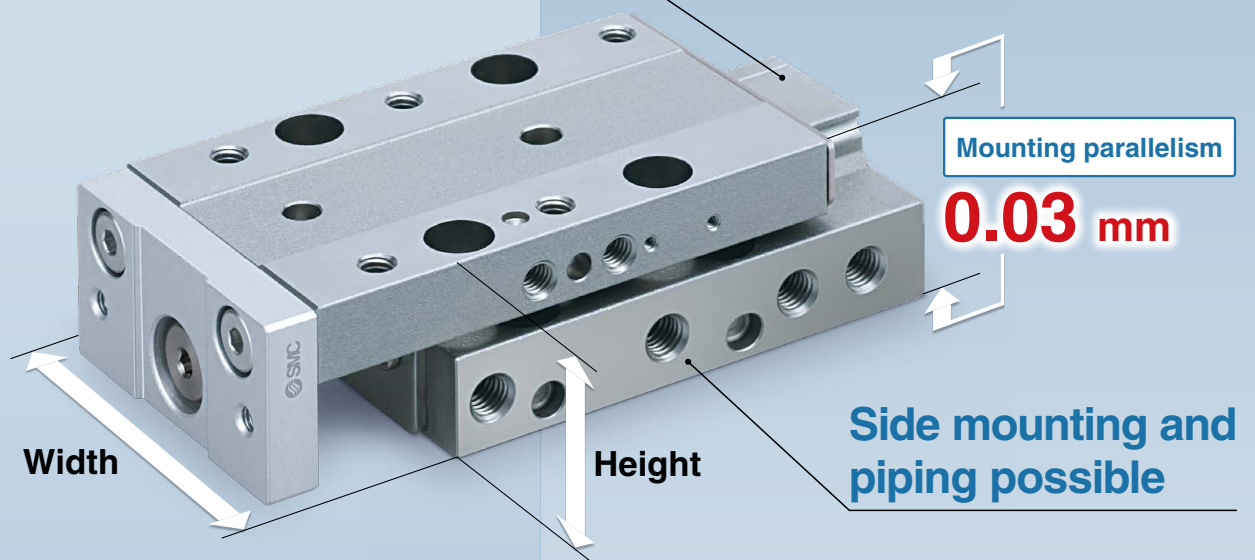

Auto switch and adjuster can be mounted on the same side.

Short pitch mounting is possible.

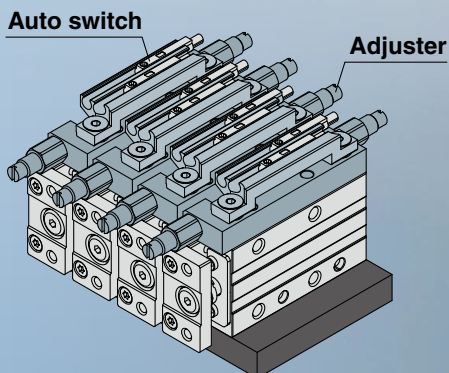



MXJ Series

SMC

CAT.ES20-252A

Compact

		[mm]				
	Bore size	Stroke	Overall length	Height	Width	Weight [g]
MXJ12 	12	10	70	18	34	227
		20	72			230
		30	82			267
		50	102			342
MXJ16 	16	10	72	23	40	340
		20	76			353
		30	86			404
		50	106			506

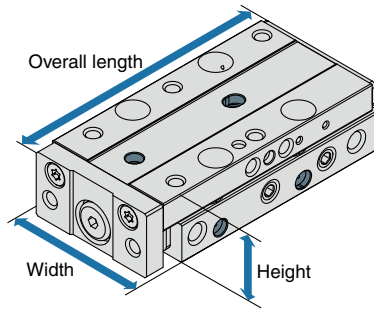

Mounting is possible from 3 directions.

Side mounting (Body tapped)

Top mounting (Through hole)

Bottom mounting (Body tapped)

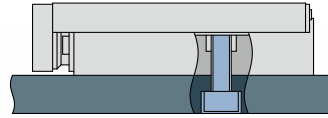
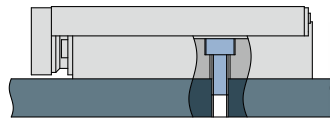
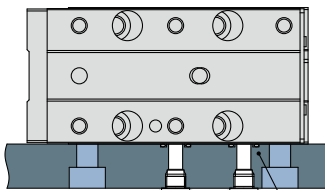

The air passage and groove for the O-ring are machined on the plate by user.
(Refer to page 25 for details.)

* Can be mounted on the opposite side

Fittings, Speed controllers

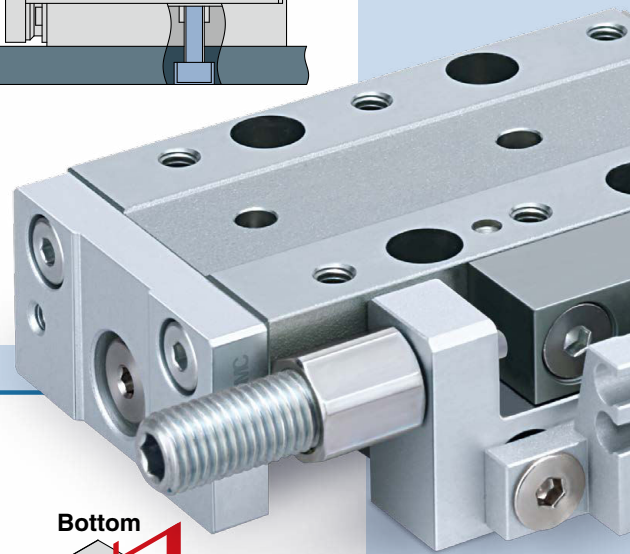

Mounting pin holes on 4 surfaces

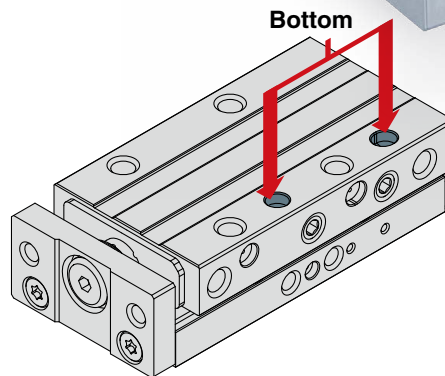
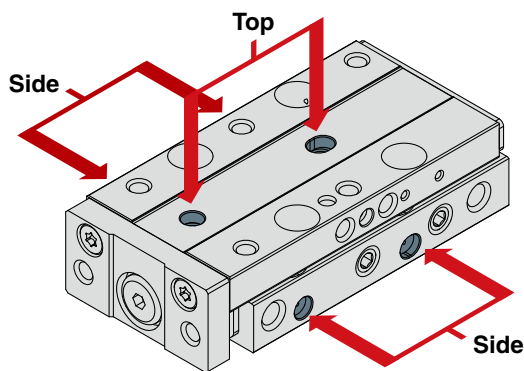

Compact auto switches are mountable.

● Solid state auto switch
D-M9□

● Reed auto switch
D-A9□
(Made to order: -X53)



Improved operability

Position of the **auto switch**, **adjuster**, and **pilot port** can be changed on site according to the installation conditions. (Refer to page 27 for details.)

1 Auto switches and adjusters can be placed on the same side.

With auto switch

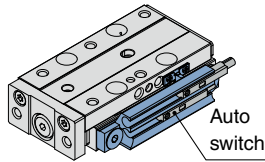

Standard mounting

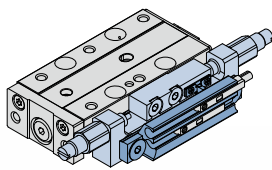

With auto switch and adjuster

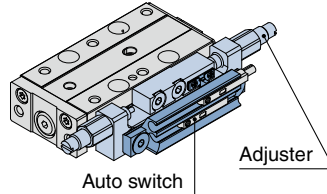

Symmetric mounting

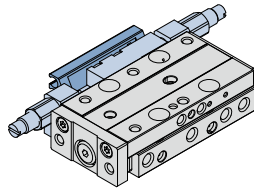

2 Pilot port location selectable

Standard type

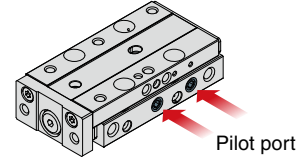

Symmetric type

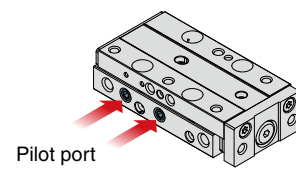

* Pilot ports on the side where the auto switch is mounted, cannot be used.

Adjuster

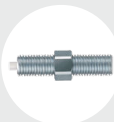

Metal Stopper with Bumper

High accuracy due to the integrated construction of the bumper and metal stopper

- Repeated positioning accuracy: ± 0.05 or less
- Improved cycle time
- Operating speed: **300 mm/s**

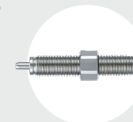

Shock Absorber Soft type/RJ

Suitable for operations which require gentle stops, such as a lightweight workpiece transfers or low-speed transfers



Rubber Stopper



Impact reduced by 1/2 compared with models without a stroke adjuster



Metal Stopper

Suitable for positioning

Series Variations

Type		Bore size [mm]	Stroke						Adjuster				Made to order From p. 15
Standard	Symmetric		5	10	15	20	30	50	Metal stopper with bumper	Rubber stopper	Shock absorber	Metal stopper	
	MXJ12L	12	•	•	•	•	•	•	•	•	•	•	<ul style="list-style-type: none"> • Long adjustment bolt (-X11, -X12) • Fluororubber seal • Anti-corrosive guide unit • Reed auto switch • Low-speed specification • Heat-resistant specification, etc.
	MXJ16L	16	•	•	•	•	•	•	•	•	•	•	

CONTENTS

Air Slide Table *MXJ Series*

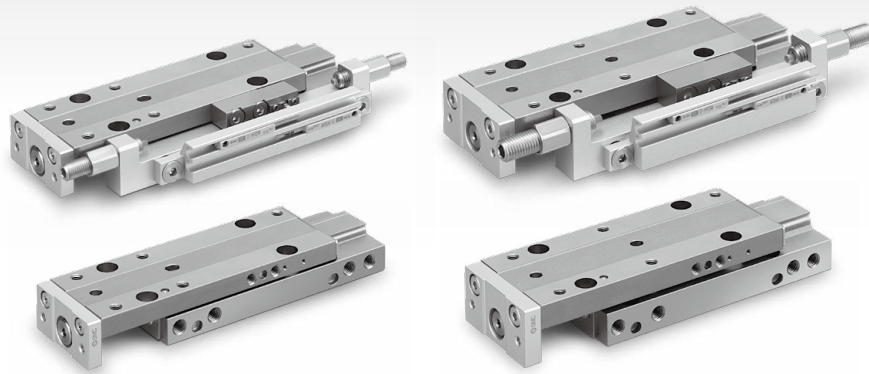

How to Order	p. 4
Specifications	p. 5
Dimensions	
MXJ12	p. 7
MXJ16	p. 9
● Adjusters	p. 11
● Auto Switch Mounting	p. 12
● Prior to Use	
Auto Switch Connections and Examples	p. 14
● Made to Order	p. 15
-X11 Long Adjustment Bolt (10 mm longer adjustment range)....	p. 16
-X12 Long Adjustment Bolt (20 mm longer adjustment range) ...	p. 16
-X39 Fluororubber Seal	p. 17
-X42 Anti-corrosive Guide Unit	p. 17
-X45 EPDM Seal	p. 17
-X53 Reed Auto Switch	p. 17
-X2128 Heat-resistant Specification (-10 to 100°C)	p. 18
-X2410 Low-speed Specification (15 to 50 mm/s)	p. 18
● Model Selection	p. 19
Specific Product Precautions	p. 23

Air Slide Table

MXJ Series

ø12, ø16



How to Order

MXJ 12 **- 10 Z** **- M9BW**

Bore size

12	12 mm
16	16 mm

Number of auto switches

Nil	2
S	1
n	n

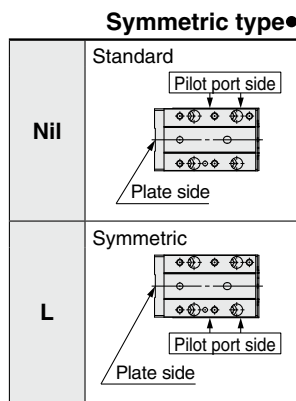

Stroke [mm]

Bore size	Stroke
12	10, 20, 30, 50
16	10, 20, 30, 50

Auto switch

Nil	Without auto switch
-----	---------------------

* For applicable auto switches, refer to the table below.

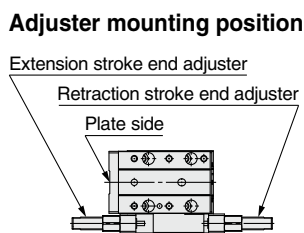

Adjuster

Symbol	Adjuster type	Adjuster mounting position	
		Extension stroke end	Retraction stroke end
Nil	Without adjuster	—	—
A	Metal stopper with bumper	●	●
B		●	—
C		—	●
D	Rubber stopper	●	●
E		●	—
F	Shock absorber	—	●
G		●	●
H		●	—
J	Metal stopper	—	●
K		●	●
L		●	—
M		—	●

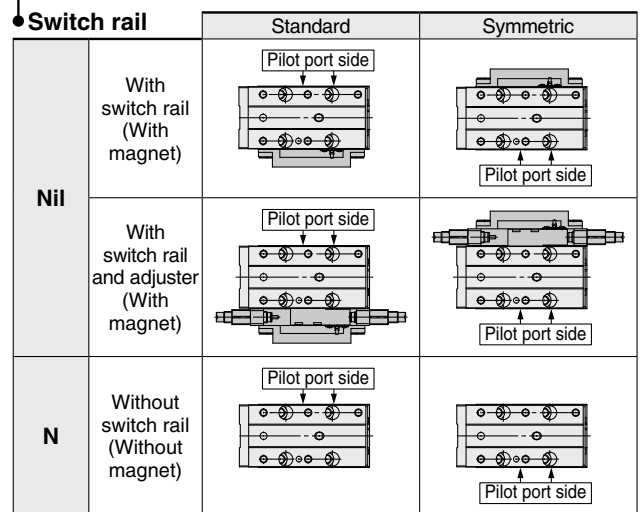

* Adjuster shown is the shock absorber type.

Applicable Auto Switches/Refer to the Web Catalog or Best Pneumatics Catalog for further information on auto switches.

Type	Special function	Electrical entry	Indicator light	Wiring (Output)	Load voltage		Auto switch model		Lead wire length [m]*2				Pre-wired connector	Applicable load	
					DC	AC	Electrical entry direction	In-line	0.5 (Nil)	1 (M)	3 (L)	5 (Z)			
Solid state auto switch	—	Grommet	Yes	3-wire (NPN)	24 V	—	M9NV	M9N	●	●	●	○	○	IC circuit	
				3-wire (PNP)					●	●	●	○			
				2-wire					●	●	●	○			
				3-wire (NPN)					●	●	●	○			
				3-wire (PNP)					●	●	●	○			
				2-wire					●	●	●	○			
	Diagnostic indication (2-color indicator)	Grommet	Yes	Yes	3-wire (NPN)	24 V	—	M9NWV	M9NW	●	●	●	○	○	IC circuit
					3-wire (PNP)					●	●	●	○		
					2-wire					●	●	●	○		
					2-wire					●	●	●	○		
Water resistant (2-color indicator)	Grommet	Yes	Yes	3-wire (NPN)	24 V	—	M9NAV*1	M9NA*1	○	○	●	○	○	IC circuit	
				3-wire (PNP)					○	○	●	○			
				2-wire					○	○	●	○			
				2-wire					○	○	●	○			

*1 Water-resistant type auto switches can be mounted on the above models, but SMC cannot guarantee water resistance.

*2 Lead wire length symbols: 0.5 m Nil (Example) M9NV
 1 m M (Example) M9NW
 3 m L (Example) M9NL
 5 m Z (Example) M9NZ

* Since there are applicable auto switches other than those listed above, refer to page 13 for details.
 * Auto switches are shipped together, but not assembled.

Caution
 When an auto switch is not mounted properly, it can cause a malfunction. Refer to "Auto Switch Mounting" on page 12.



MXJ Series

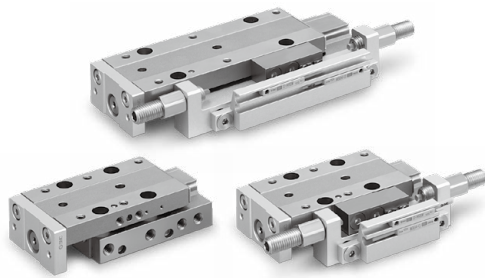

Made to Order
(For details, refer to pages 15 to 18.)

Symbol	Specifications
-X11	Long adjustment bolt (10 mm longer adjustment range)
-X12	Long adjustment bolt (20 mm longer adjustment range)
-X39	Fluororubber seal
-X42	Anti-corrosive guide unit
-X45	EPDM seal
-X53	Reed auto switch
-X2128	Heat-resistant specification (-10 to 100°C)
-X2410	Low-speed specification (15 to 50 mm/s)

Specifications

Model	MXJ12	MXJ16
Bore size [mm]	12	16
Piping port size	M5 x 0.8	
Fluid	Air	
Action	Double acting	
Operating pressure*1	0.1 to 0.7 MPa	
Proof pressure	1.05 MPa	
Ambient and fluid temperatures	-10 to 60°C	
Piston speed (Average speed)*2	50 to 500 mm/s (Metal stopper: 50 to 200 mm/s) (Metal stopper with bumper: 50 to 300 mm/s)	
Cushion (Without adjuster)	Rubber bumper	
Cushion (With adjuster)	Metal stopper, Metal stopper with bumper, Rubber stopper, Shock absorber	
Lubrication	Non-lube	
Auto switch	Solid state auto switch (2-wire, 3-wire), 2-color indicator solid state auto switch (2-wire, 3-wire)	
Stroke length tolerance	+2 to 0 mm (When no pressure is applied)	

*1 Refer to page 24 for the minimum operating pressure of the metal stopper with bumper. If the operating pressure is lower than the minimum operating pressure, the repeated accuracy will decline.

Minimum operating pressure of the metal stopper with bumper: Pressure required to fully compress the protrusion of the bumper to get in contact with the metal part

*2 Set the piston speed so that the allowable kinetic energy of piston speed on page 6 is not exceeded. Please consider the weight of the moving parts. For some product models, the allowable kinetic energy can be exceeded only by the weight of the moving parts.

Theoretical Output

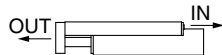

Model	Bore size [mm]	Rod size [mm]	Operating direction	Piston area [mm ²]	Operating pressure [MPa]					
					0.2	0.3	0.4	0.5	0.6	0.7
MXJ12	12	6	OUT	113	23	34	45	57	68	79
			IN	85	17	25	34	42	51	59
MXJ16	16	6	OUT	201	40	60	80	101	121	141
			IN	173	35	52	69	86	104	121

Weight

Basic Model (Without switch rail)

[g]

Model	Standard stroke [mm]			
	10	20	30	50
MXJ12	227	230	267	342
MXJ16	340	353	404	506

Additional Weight of Switch Rail

[g]

Model	Standard stroke [mm]			
	10	20	30	50
MXJ12	10	10	11	13
MXJ16	12	13	14	18

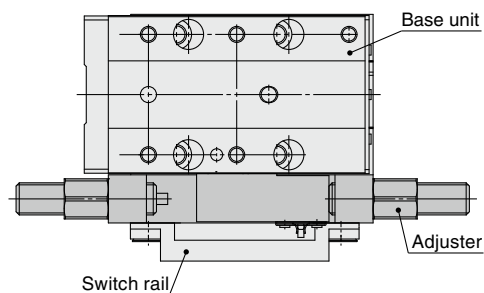

Additional Weight of Adjustment Unit

[g]

Model	Standard stroke [mm]				Additional weight of adjuster*1			
	10	20	30	50	Metal stopper with bumper	Rubber stopper	Shock absorber	Metal stopper
MXJ12	36	39	41	46	9	9	9	9
MXJ16	63	67	71	78	17	17	20	18

*1 Weights shown are for one adjuster. Double the weight in the table when the adjuster is used for both ends (extension/retraction).

For details on cylinders with auto switches ⇨ pp. 12, 13

- Auto Switch Proper Mounting Position (Detection at stroke end)
- Operating Range
- Auto Switch Mounting
- Switch Rail Assembly

Caution
Refer to "Prior to Use" on page 14.

Maximum Allowable Load Mass: m max

Model	Maximum load mass [kg]	
	Without adjuster Rubber stopper Shock absorber	Metal stopper with bumper Metal stopper
MXJ12	0.8	0.5
MXJ16	1.5	1

Maximum Allowable Moment (Reference Values)

Model	Pitch, Yaw	Roll
MXJ12	4.5	5.3
MXJ16	6.4	9.2

* A model cannot be selected with the maximum allowable moment. Select a model according to the model selection steps on page 19.

Allowable Kinetic Energy: J

Model	Without adjuster	Metal stopper with bumper	Rubber stopper	Shock absorber	Metal stopper
MXJ12	0.05	0.015	0.05	0.245	0.012
MXJ16	0.069	0.023 (0.017)*1	0.069	0.49	0.02 (0.014)*1

*1 When the MXJ16 is side mounted and used with metal stoppers or metal stoppers with bumper, keep the kinetic energy below the value shown in brackets ().

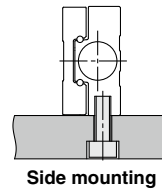

$$\text{Kinetic energy } E \text{ [J]} = \frac{(m1 + m2)V^2}{2}$$

m1: Weight of cylinder moving parts kg
m2: Load mass kg
V: Piston speed at the end m/s

$$V = 1.4 Va$$

Va: Average piston speed

* Average piston speed: Speed that the stroke is divided by a period of time from starting the operation to reaching the end.

Weight of Moving Parts: m1

Model	Weight of moving parts [g]				Additional weight of magnet	Additional weight of adjustment block
	Stroke [mm]					
	10	20	30	50		
MXJ12	96	99	115	147	0.61	16
MXJ16	138	147	168	211	0.61	30

Accuracy

Stroke	10, 20, 30	50
B side parallelism to A side	0.03 mm	
E side parallelism to D side	0.03 mm	
B side traveling parallelism to A side	0.005 mm	0.008 mm
E side traveling parallelism to D side	0.005 mm	0.008 mm
M dimension tolerance	±0.05 mm	
W dimension tolerance	±0.05 mm	
End deflection	±0.003 mm	
Non-rotating table accuracy (deg) at the retracted end	±0.02	

* The table displays the values for an unloaded, unpressurised cylinder without deflection. The values are recorded at 20°C ±5°C.

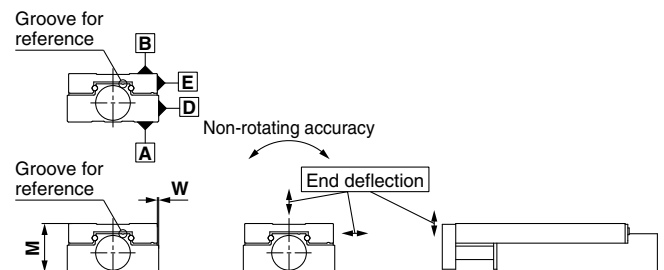

Adjuster Specifications/Refer to page 11 for adjuster models and dimensions.

Metal Stopper with Bumper

Model	MXJ12	MXJ16
Stroke absorption [mm]	2	2.8
Min. operating pressure of metal stopper with bumper*1 [MPa]	0.3	0.3
Full compression force of bumper [N]	20	42
Mounting screw size	M6 x 0.75	M8 x 1

*1 Minimum operating pressure required to fully compress the protrusion of the bumper to get in contact with the metal part
 When using the metal stopper with bumper for positioning, use it at a pressure level exceeding the minimum operating pressure. For vertical mounting, the workpiece mass should be taken into consideration. For details, refer to Specific Product Precautions on page 24.

Shock Absorber/RJ

Model	MXJ12	MXJ16
Stroke absorption [mm]	4	6
Collision speed [mm/s]	50 to 500	
Max. operating frequency [cycle/min]	20	42
Max. allowable thrust [N]	150	245
Spring force (Extended) [N]	1.3	2.8
Spring force (Compressed) [N]	3.9	5.4
Mounting screw size	M6 x 0.75	M8 x 1
Shock absorber part number	RJ0604N	RJ0806LN

MXJ Series

Dimensions

Basic model (Without switch rail)

MXJ12-□ZN

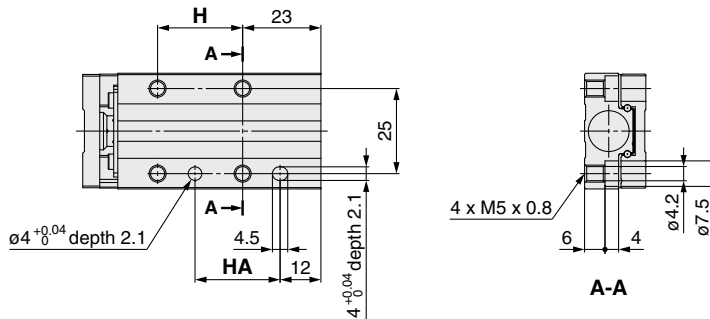
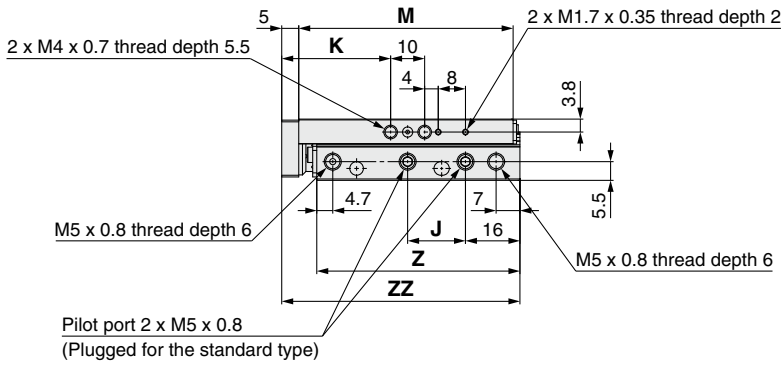
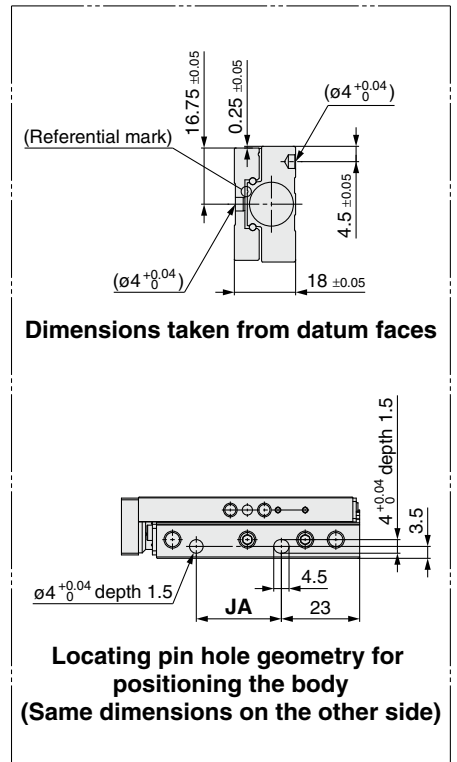
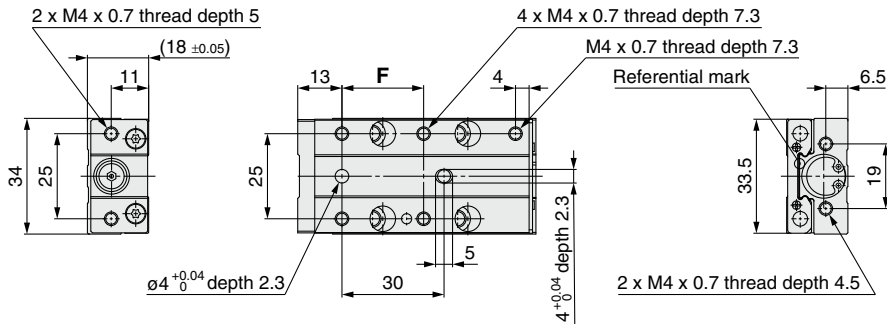
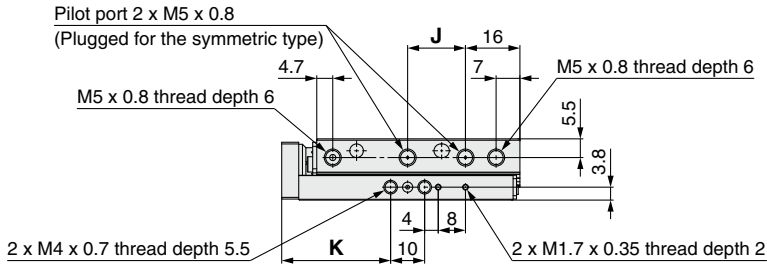

Dimensions

[mm]

Model	F	H	HA	J	JA	K	M	Z	ZZ
MXJ12-10ZN	24	25	25	17	25	32	63	59.7	70
MXJ12-20ZN	26	27	27	27	27	34	65	61.7	72
MXJ12-30ZN	26	37	37	37	37	44	75	71.7	82
MXJ12-50ZN	26	57	57	57	57	64	95	91.7	102

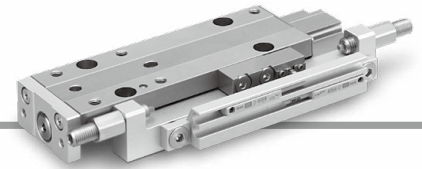

Dimensions

MXJ12-□Z□N (With adjuster)

Metal stopper with bumper **A**: Both ends, **B**: Extension stroke end, **C**: Retraction stroke end

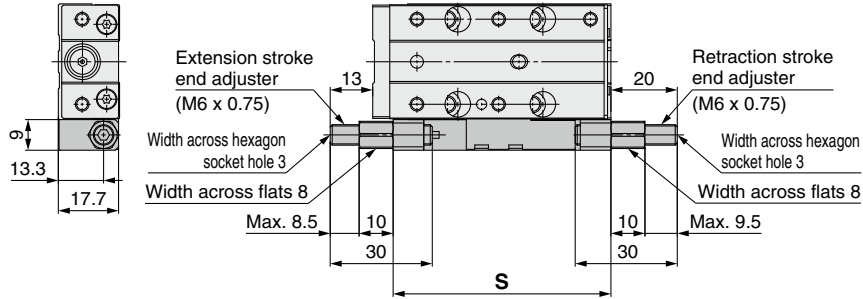

Dimensions [mm]	
Model	S
MXJ12-10Z□N	64
MXJ12-20Z□N	74
MXJ12-30Z□N	84
MXJ12-50Z□N	104

Rubber stopper **D**: Both ends, **E**: Extension stroke end, **F**: Retraction stroke end

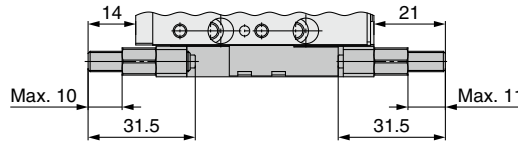

Shock absorber **G**: Both ends, **H**: Extension stroke end, **J**: Retraction stroke end

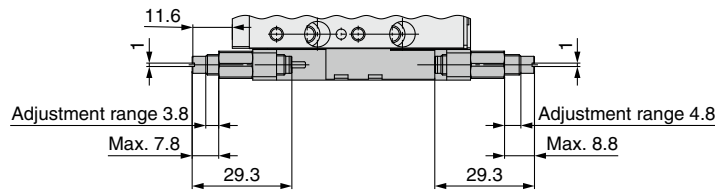

Metal stopper **K**: Both ends, **L**: Extension stroke end, **M**: Retraction stroke end

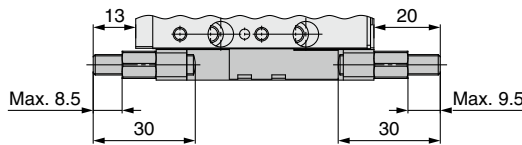

With switch rail
MXJ12-□Z

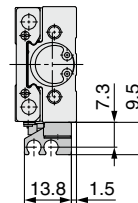
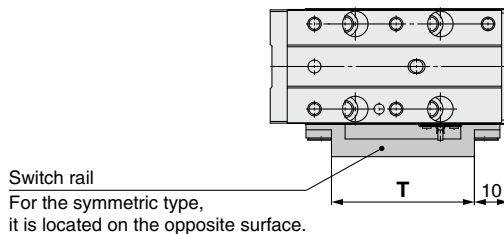

Dimensions [mm]	
Model	T
MXJ12-10Z	42
MXJ12-20Z	44
MXJ12-30Z	54
MXJ12-50Z	74

With switch rail and adjuster

Standard type
MXJ12-□Z□

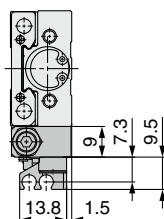
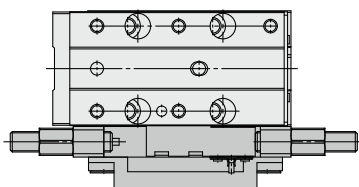

Symmetric type
MXJ12L-□Z□

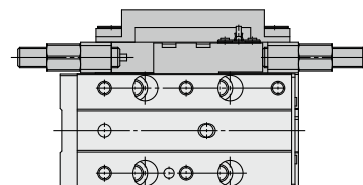

MXJ Series

Dimensions

Basic model (Without switch rail)

MXJ16-□ZN

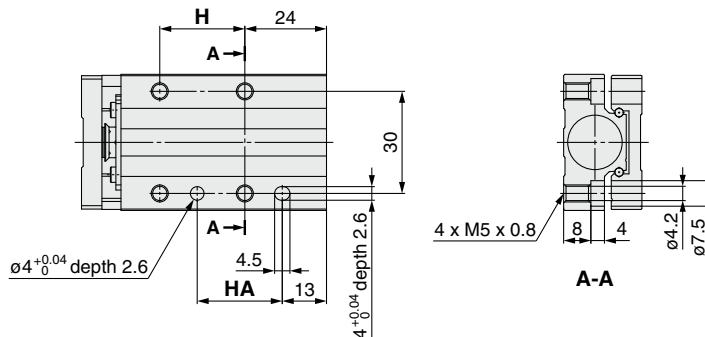
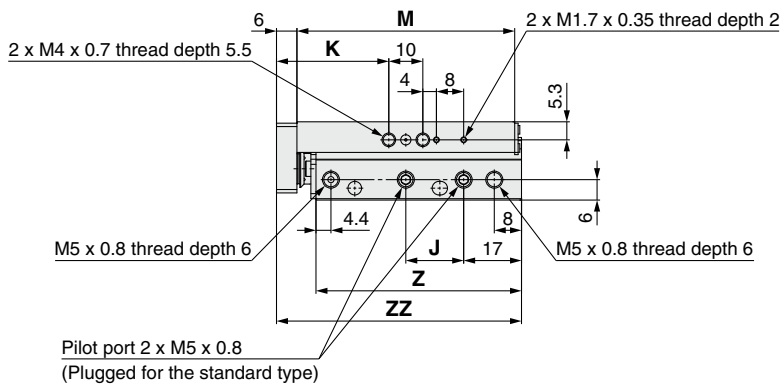
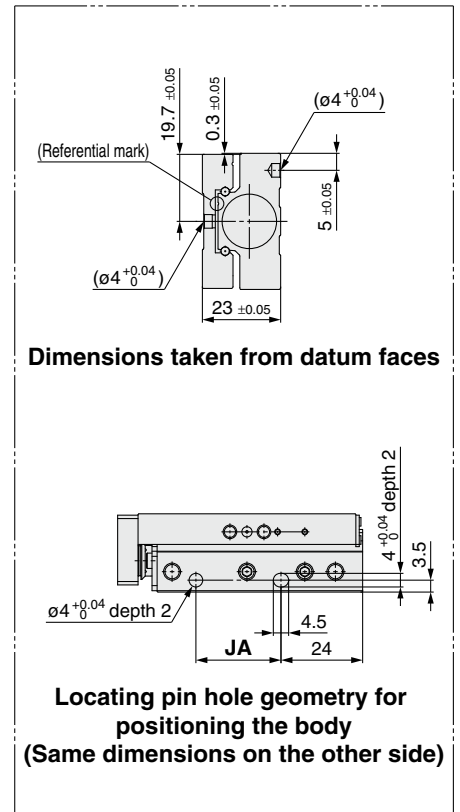
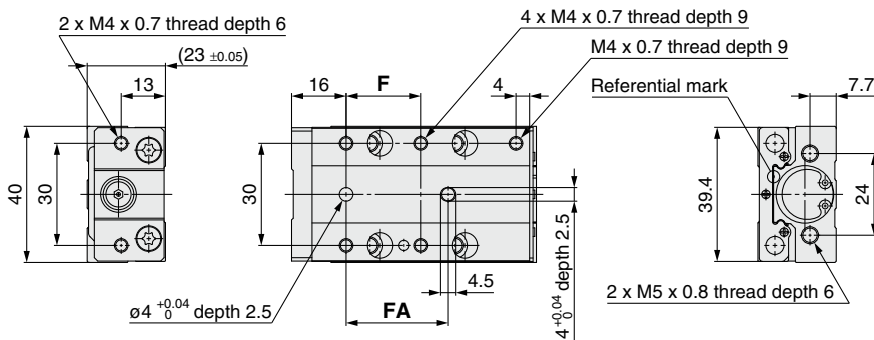
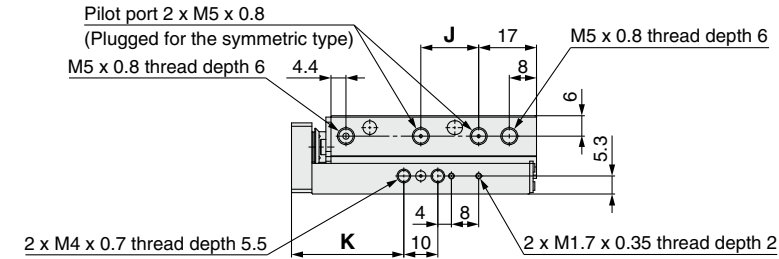
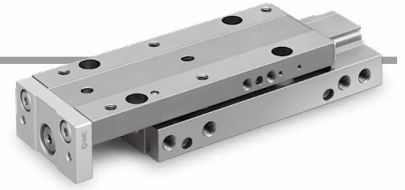

Dimensions

Model	F	FA	H	HA	J	JA	K	M	Z	ZZ
MXJ16-10ZN	22	30	25	25	17	25	33	64	60.4	72
MXJ16-20ZN	26	30	29	29	27	29	37	68	64.4	76
MXJ16-30ZN	36	40	39	39	37	39	47	78	74.4	86
MXJ16-50ZN	36	40	59	59	59	59	67	98	94.4	106

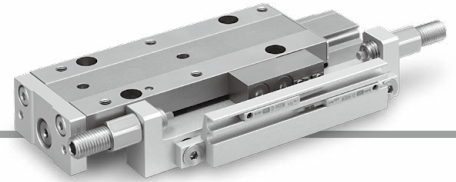

Dimensions

MXJ16-□Z□N (With adjuster)

Metal stopper with bumper **A**: Both ends, **B**: Extension stroke end, **C**: Retraction stroke end

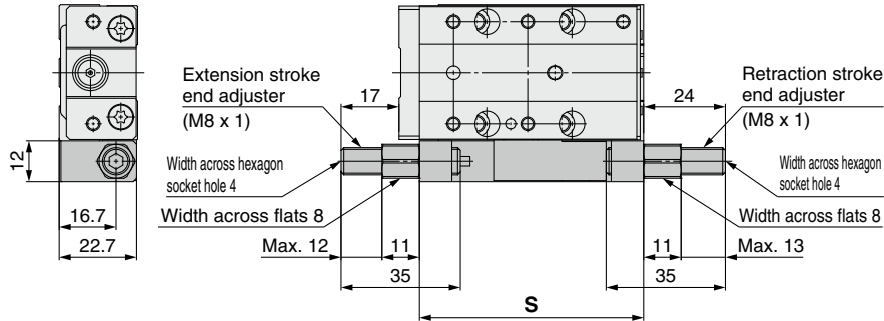

Dimensions [mm]	
Model	S
MXJ16-10Z□N	66
MXJ16-20Z□N	76
MXJ16-30Z□N	86
MXJ16-50Z□N	106

Rubber stopper **D**: Both ends, **E**: Extension stroke end, **F**: Retraction stroke end

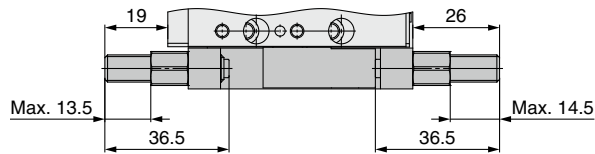

Shock absorber **G**: Both ends, **H**: Extension stroke end, **J**: Retraction stroke end

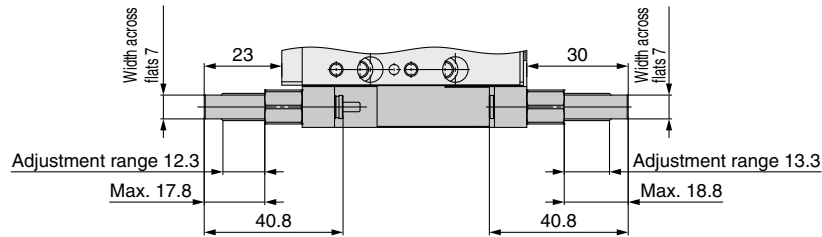

Metal stopper **K**: Both ends, **L**: Extension stroke end, **M**: Retraction stroke end

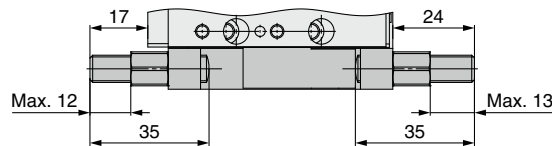

**With switch rail
MXJ16-□Z**

Switch rail
For the symmetric type, it is located on the opposite surface.

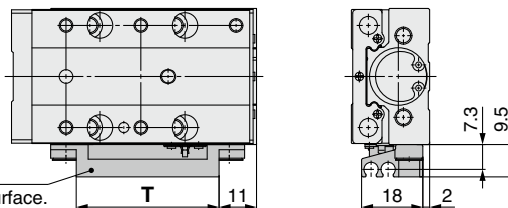

Dimensions [mm]	
Model	T
MXJ16-10Z	42
MXJ16-20Z	46
MXJ16-30Z	56
MXJ16-50Z	76

With switch rail and adjuster

**Standard type
MXJ16-□Z□**

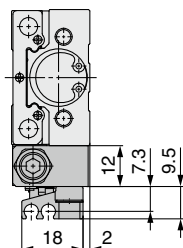
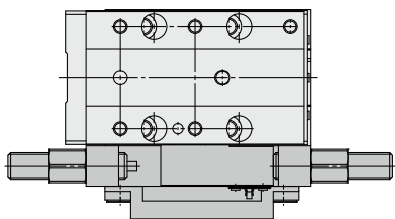

**Symmetric type
MXJ16L-□Z□**

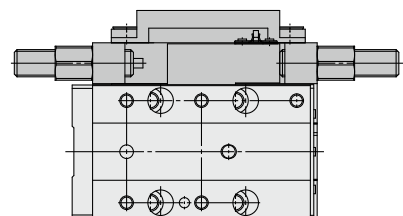

MXJ Series Adjusters

How to Order

MXJZ - **C** **12** - **10** **A**

Adjuster type			Bore size	Stroke	Mounting bolt		
Symbol	Adjuster type	Adjuster mounting position			Symbol	Mounting type	Bolt size
C	Metal stopper with bumper	Both ends	12	10	A	For adjustment plate mounting	MXJ12: M5 x 14 MXJ16: M5 x 17
A	Rubber stopper						
J	Shock absorber						
D	Metal stopper						
CS	Metal stopper with bumper	One side	16	20	B	For adjustment plate and switch rail mounting	MXJ12: M5 x 19 MXJ16: M5 x 22
AS	Rubber stopper						
JS	Shock absorber						
DS	Metal stopper						

Dimensions

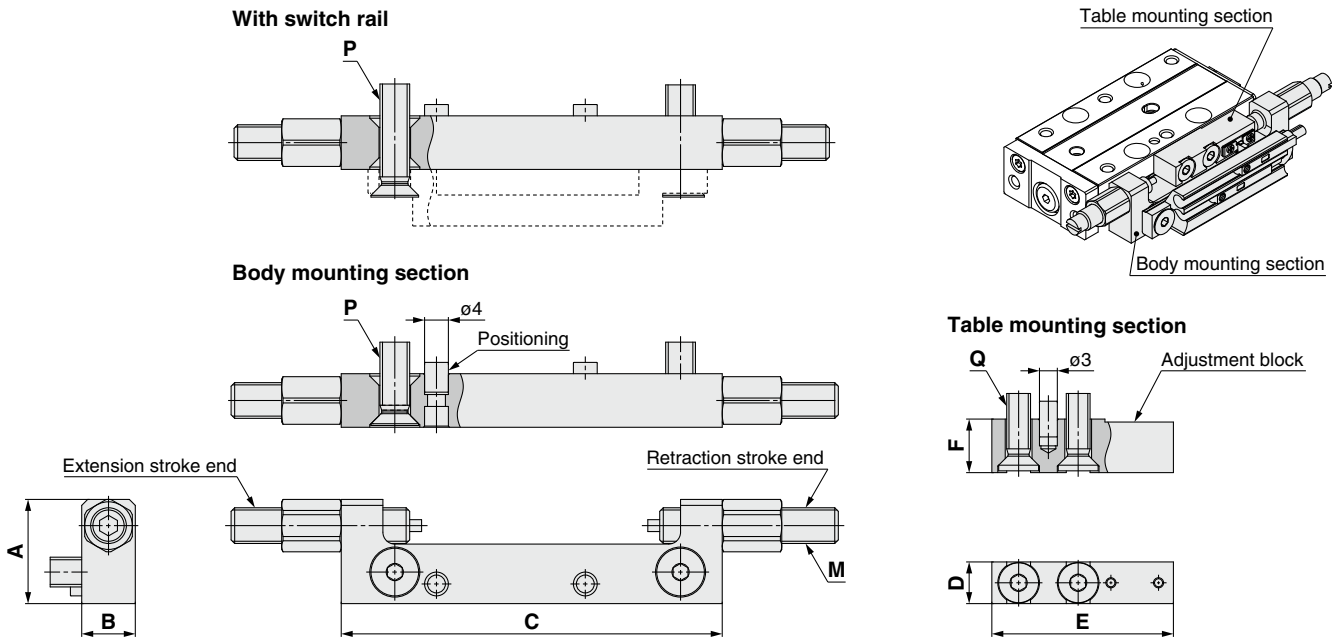

Model	Adjuster type	Adjuster part number*1		Adjustment bolt part no.		Body mounting section					Table mounting section						
		Both ends	One side (Extension stroke end, Retraction stroke end)	With nut	Without nut	A	B	C				M (Fine pitch)	P	D	E	F	Q
								Stroke									
MXJ12	Metal stopper with bumper	MXJZ-C12-□□A	MXJZ-CS12-□□A	MXJZ-CT12	MXQA-A887	17.4	9	64.5	74.5	84.5	104.5	M6 x 0.75	M5 x 14	7	30.5	9	M4 x 13
		MXJZ-C12-□□B	MXJZ-CS12-□□B										M5 x 19				
	Rubber stopper	MXJZ-A12-□□A	MXJZ-AS12-□□A	MXJZ-AT12	MXQA-A827								M5 x 14				
		MXJZ-A12-□□B	MXJZ-AS12-□□B										M5 x 19				
	Shock absorber	MXJZ-J12-□□A	MXJZ-JS12-□□A	MXJZ-JT12	RJ0604N								M5 x 14				
	MXJZ-J12-□□B	MXJZ-JS12-□□B			M5 x 19												
	Metal stopper	MXJZ-D12-□□A	MXJZ-DS12-□□A	MXJZ-DT12	MXQA-A838	M5 x 14											
		MXJZ-D12-□□B	MXJZ-DS12-□□B			M5 x 19											
MXJ16	Metal stopper with bumper	MXJZ-C16-□□A	MXJZ-CS16-□□A	MXJZ-CT16	MXQA-A1287	22.2	12	66	76	86	106	M8 x 1	M5 x 17	10	32	12	M4 x 16
		MXJZ-C16-□□B	MXJZ-CS16-□□B										M5 x 22				
	Rubber stopper	MXJZ-A16-□□A	MXJZ-AS16-□□A	MXJZ-AT16	MXQA-A1227								M5 x 17				
		MXJZ-A16-□□B	MXJZ-AS16-□□B										M5 x 22				
	Shock absorber	MXJZ-J16-□□A	MXJZ-JS16-□□A	MXJZ-JT16	RJ0806LN								M5 x 17				
	MXJZ-J16-□□B	MXJZ-JS16-□□B			M5 x 22												
	Metal stopper	MXJZ-D16-□□A	MXJZ-DS16-□□A	MXJZ-DT16	MXQA-A1238	M5 x 17											
		MXJZ-D16-□□B	MXJZ-DS16-□□B			M5 x 22											

*1 The adjustment bolt and shock absorber are included.

MXJ Series Auto Switch Mounting

Auto Switch Proper Mounting Position (Detection at stroke end)

Lead wire, in-line entry (Without adjuster)

Solid state auto switch

D-M9□

D-M9□W

D-M9□A

Model	A				B				C			
	Stroke				Stroke				Stroke			
	10	20	30	50	10	20	30	50	10	20	30	50
MXJ12	14.5	6.5	6.5	6.5	24.5	26.5	36.5	56.5	7.5	7.5	7.5	7.5
MXJ16	14.5	8.5	8.5	8.5	24.5	28.5	38.5	58.5	7.5	7.5	7.5	7.5

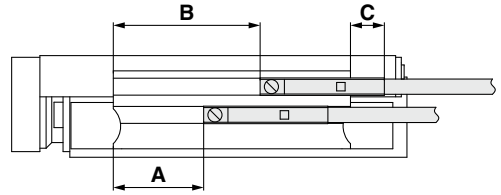

Lead wire, perpendicular entry (Without adjuster)

Solid state auto switch

D-M9□V

D-M9□WV

D-M9□AV

Model	A				D			
	Stroke				Stroke			
	10	20	30	50	10	20	30	50
MXJ12	14.5	6.5	6.5	6.5	2.5	2.5	2.5	2.5
MXJ16	14.5	8.5	8.5	8.5	2.5	2.5	2.5	2.5

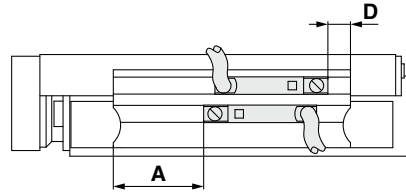

Lead wire, in-line entry (With adjuster)

Solid state auto switch

D-M9□

D-M9□W

D-M9□A

Model	A				B				C			
	Stroke				Stroke				Stroke			
	10	20	30	50	10	20	30	50	10	20	30	50
MXJ12	16	8	8	8	26	28	38	58	9	9	9	9
MXJ16	16.5	10.5	10.5	10.5	26.5	30.5	38.5	60.5	9.5	9.5	9.5	9.5

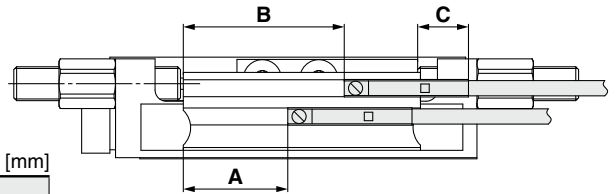

Lead wire, perpendicular entry (With adjuster)

Solid state auto switch

D-M9□V

D-M9□WV

D-M9□AV

Model	A				D			
	Stroke				Stroke			
	10	20	30	50	10	20	30	50
MXJ12	16	8	8	8	1	1	1	1
MXJ16	16.5	10.5	10.5	10.5	0.5	0.5	0.5	0.5

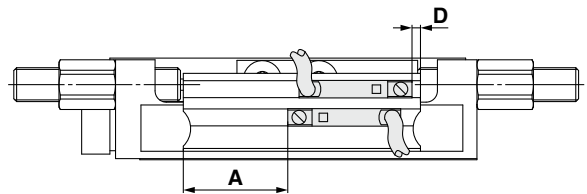

Operating Range

Auto switch model	MXJ12	MXJ16
D-M9□, M9□V	1.5	1.5
D-M9□W, M9□WV		
D-M9□A, M9□AV		

* Values which include hysteresis are for reference purposes only. They are not a guarantee (assuming approximately ±30% dispersion) and may change substantially depending on the ambient environment.

MXJ Series

Auto Switch Mounting

⚠ Caution

1. Auto switch mounting tool

When tightening the auto switch mounting screw (included with the auto switch), use a watchmaker's screwdriver with a handle diameter of about 5 to 6 mm.

Tightening torque

Tightening Torque of

Auto switch model	Tightening torque [N·m]
D-M9□(V) D-M9□W(V) D-M9□A(V)	0.05 to 0.15

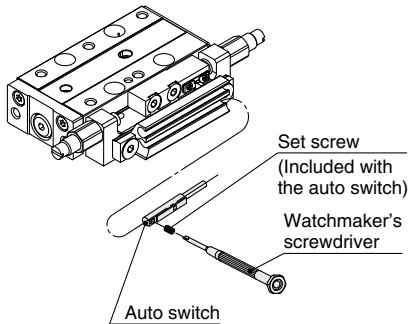

2. Maintain a minimum gap (L) if standard type and symmetric type are used side by side.

If the space is insufficient, it may cause auto switches to malfunction.

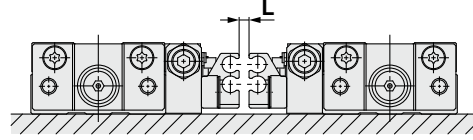

L Dimension [mm]

Without shielding plate	4.5
With shielding plate	2.5

Placing in the shield plate (0.2 to 0.3 mm iron plate) between the products allows the distance to be smaller.

3. Maintain a minimum gap (L) if multiple products are side mounted next to each other.

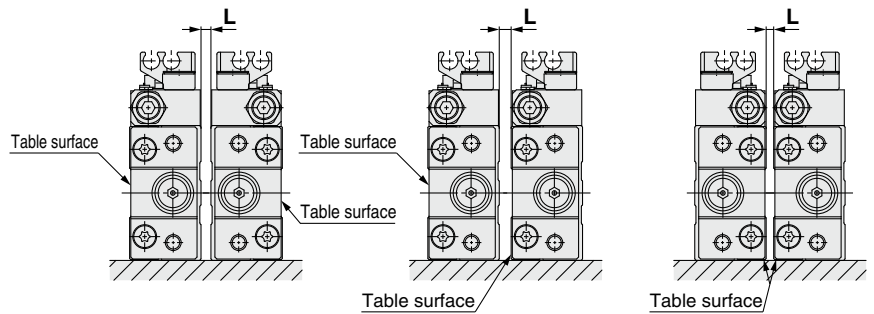

L Dimension [mm]

Without shielding plate	1
With shielding plate	

Switch Rail Assembly

MXJZ - AD 12 - 10 N

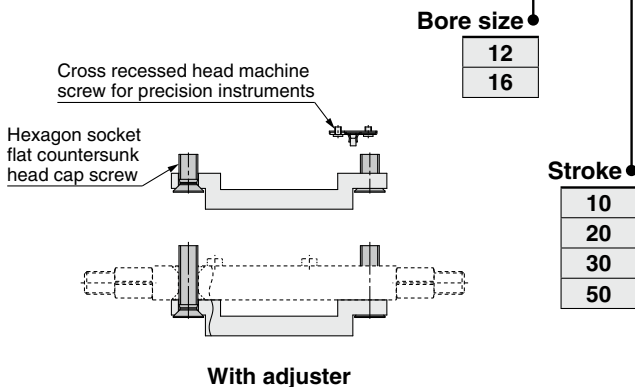

• Mounting bolt

Symbol	Mounting type	Hexagon socket flat countersunk head cap screw	Cross recessed head machine screw for precision instruments
N	None*1		M1.7 x 2
B	For adjustment plate and switch rail mounting	MXJ12: M5 x 19 MXJ16: M5 x 22	M1.7 x 2
C	For switch rail mounting	MXJ12: M5 x 10 MXJ16: M5 x 10	M1.7 x 2

*1 The bolt is included in the adjuster when ordering the adjuster and switch rail assembly together.

Other than the applicable auto switches listed in "How to Order," the following auto switches are also mountable.

* Normally closed (NC = b contact) solid state auto switches (D-F9G/F9H) are also available. For details, refer to the **Web Catalog**.

Prior to Use

Auto Switch Connections and Examples

Sink Input Specifications

3-wire, NPN

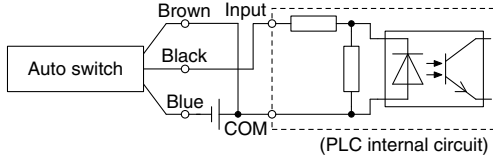

2-wire

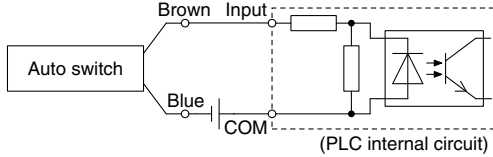

Source Input Specifications

3-wire, PNP

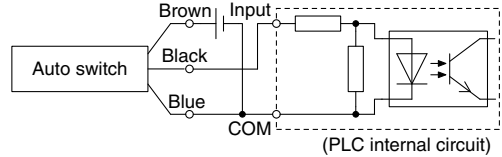

2-wire

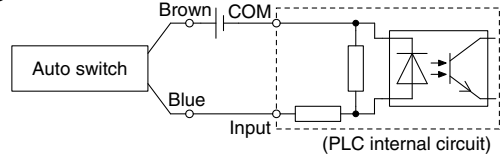

Connect according to the applicable PLC input specifications, as the connection method will vary depending on the PLC input specifications.

Examples of AND (Series) and OR (Parallel) Connections

* When using solid state auto switches, ensure the application is set up so the signals for the first 50 ms are invalid. Depending on the operating environment, the product may not operate properly.

3-wire AND connection for NPN output (Using relays)

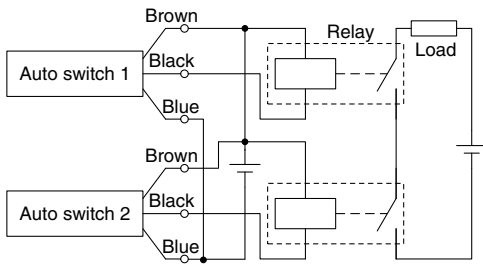

(Performed with auto switches only)

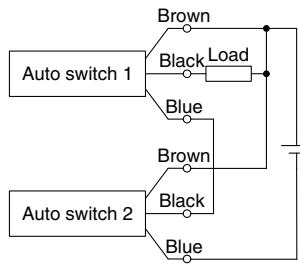

3-wire OR connection for NPN output

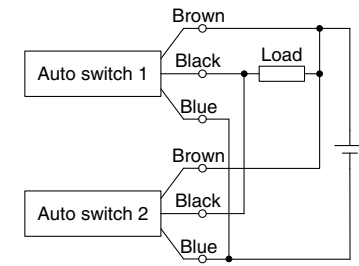

3-wire AND connection for PNP output (Using relays)

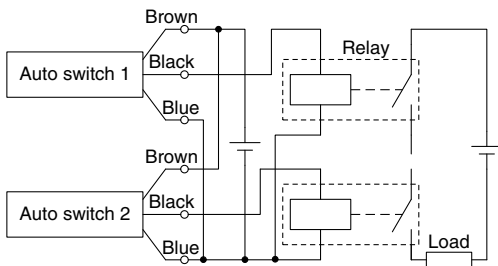

(Performed with auto switches only)

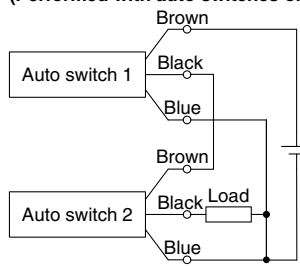

3-wire OR connection for PNP output

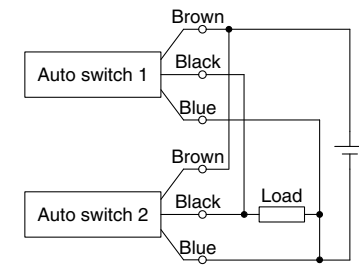

2-wire AND connection

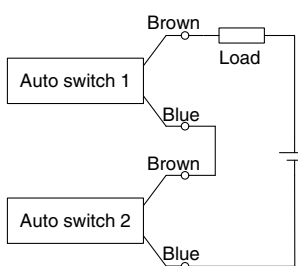

When two auto switches are connected in series, a load may malfunction because the load voltage will decline when in the ON state. The indicator lights will light up when both of the auto switches are in the ON state. Auto switches with a load voltage less than 20 V cannot be used.

$$\begin{aligned} \text{Load voltage at ON} &= \text{Power supply voltage} - \\ &\quad \text{Residual voltage} \times 2 \text{ pcs.} \\ &= 24 \text{ V} - 4 \text{ V} \times 2 \text{ pcs.} \\ &= 16 \text{ V} \end{aligned}$$

Example: Power supply is 24 VDC
Internal voltage drop in auto switch is 4 V.

2-wire OR connection

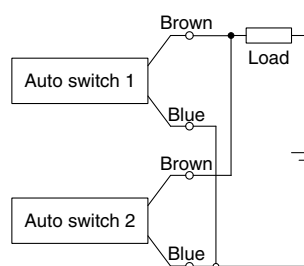

(Solid state)
When two auto switches are connected in parallel, malfunction may occur because the load voltage will increase when in the OFF state.

(Reed)
Because there is no current leakage, the load voltage will not increase when turned OFF. However, depending on the number of auto switches in the ON state, the indicator lights may sometimes grow dim or not light up, due to the dispersion and reduction of the current flowing to the auto switches.

$$\begin{aligned} \text{Load voltage at OFF} &= \text{Leakage current} \times 2 \text{ pcs.} \times \\ &\quad \text{Load impedance} \\ &= 1 \text{ mA} \times 2 \text{ pcs.} \times 3 \text{ k}\Omega \\ &= 6 \text{ V} \end{aligned}$$

Example: Load impedance is 3 k Ω .
Leakage current from auto switch is 1 mA.

MXJ Series

Made to Order

Please contact SMC for detailed specifications, delivery, and prices.



No.	Symbol	Specifications	Page
1	-X11	Long adjustment bolt (10 mm longer adjustment range)	16
2	-X12	Long adjustment bolt (20 mm longer adjustment range)	16
3	-X39	Fluororubber seal	17
4	-X42	Anti-corrosive guide unit	17
5	-X45	EPDM seal	17
6	-X53	Reed auto switch	17
7	-X2128	Heat-resistant specification (-10 to 100°C)	18
8	-X2410	Low-speed specification (15 to 50 mm/s)	18

1 Long Adjustment Bolt (10 mm longer adjustment range) Symbol **-X11**

The stroke adjustment range has been increased by 10 mm compared with the standard product by making the adjustment bolt longer. For the adjustment range, refer to the table below.

- * -X11 is not available with shock absorber.
- * For MXJ16, "-X11" is not necessary for 10 mm stroke because the stroke adjustment range of standard products is 10 mm or more, but it is possible to order.

MXJ	Standard model no. (Refer to page 4.)	- X11
	Standard adjuster part no. (Refer to page 11.)	
	Standard adjustment bolt part no. (Refer to page 11.)	

Long adjustment bolt (10 mm longer adjustment range) ●

Dimensions

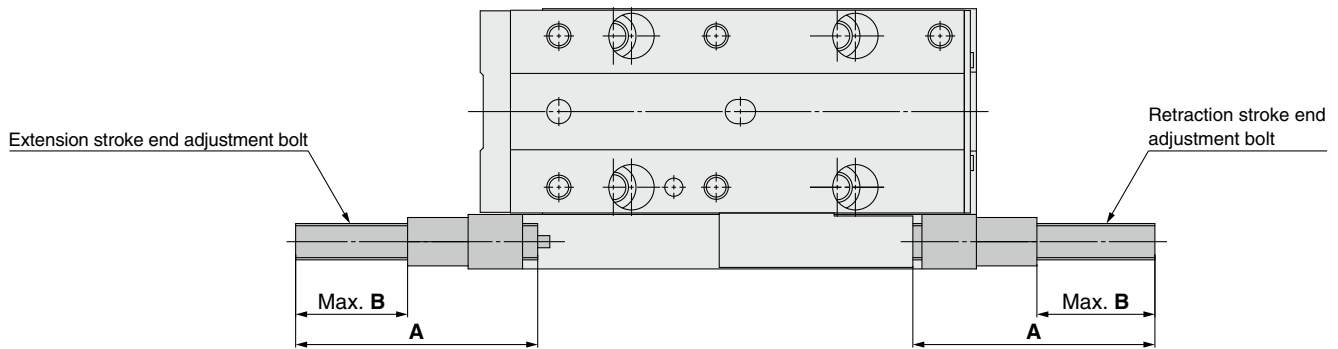

Metal Stopper with Bumper [mm]		
Model	A	B
MXJ12	40	18
MXJ16	45	22

Rubber Stopper [mm]		
Model	A	B
MXJ12	41.5	20
MXJ16	46.5	23.5

Metal Stopper [mm]		
Model	A	B
MXJ12	40	18
MXJ16	45	22

2 Long Adjustment Bolt (20 mm longer adjustment range) Symbol **-X12**

The stroke adjustment range has been increased by 20 mm compared with the standard product by making the adjustment bolt longer. For the adjustment range, refer to the table below.

- * -X12 is not available with shock absorber.
- * For MXJ16, "-X12" is not necessary for 10 or 20 mm stroke because the stroke adjustment range of -X11 is 20 mm or more, but it is possible to order.

MXJ	Standard model no. (Refer to page 4.)	- X12
	Standard adjuster part no. (Refer to page 11.)	
	Standard adjustment bolt part no. (Refer to page 11.)	

Long adjustment bolt (20 mm longer adjustment range) ●

Dimensions

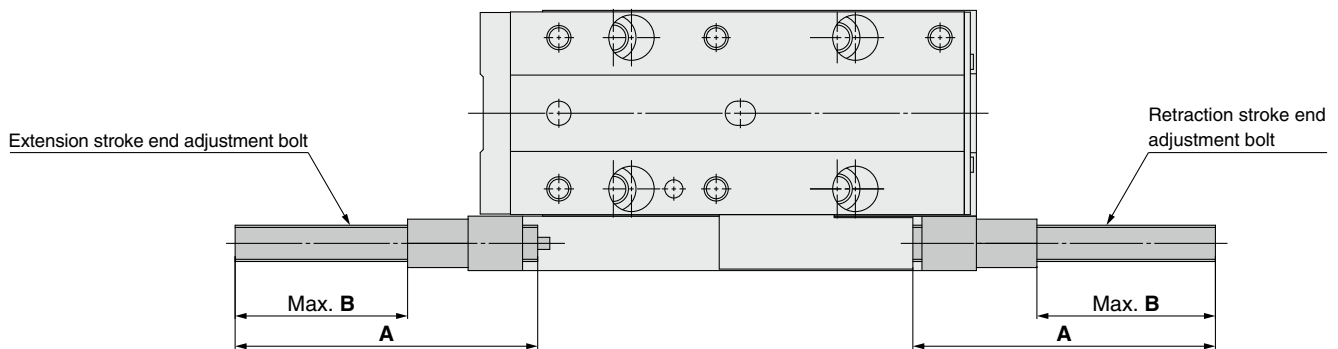

Metal Stopper with Bumper [mm]		
Model	A	B
MXJ12	50	28
MXJ16	55	32

Rubber Stopper [mm]		
Model	A	B
MXJ12	51.5	30
MXJ16	56.5	33.5

Metal Stopper [mm]		
Model	A	B
MXJ12	50	28
MXJ16	55	32

3 Fluororubber Seal

Symbol
-X39

This specification changes the materials for the piston seal, rod seal, and O-rings to fluororubber.

MXJ Standard model no. - **X39**
● Fluororubber seal

Specifications

Seal material	Fluororubber
---------------	--------------

* Dimensions and specifications other than the above are the same as the standard type.

4 Anti-corrosive Guide Unit

Symbol
-X42

Martensitic stainless steel is used for the table and body. Use this treatment if more effective anti-corrosiveness is necessary. Table and body are given anti-corrosive treatment.

MXJ Standard model no. - **X42**
● Anti-corrosive guide unit

Specifications

Surface treatment	Special anti-corrosive treatment*1
-------------------	------------------------------------

*1 Special anti-corrosive treatment makes the table and the body black.
* Dimensions and specifications other than the above are the same as the standard type.

5 EPDM Seal

Symbol
-X45

This specification changes the materials for the piston seal, rod seal, and O-rings to EPDM.

MXJ Standard model no. - **X45**
● EPDM seal

Specifications

Seal material	EPDM
Grease	PTFE grease

* Dimensions and specifications other than the above are the same as the standard type.

Warning

Precautions

Be aware that smoking cigarettes, etc., after your hands have come into contact with the grease used in this product can create a gas that is hazardous to humans.

6 Reed Auto Switch

Symbol
-X53

Reed auto switch can be used by changing to a stronger magnet.

MXJ Standard model no. - **A93** - **X53**
● Reed auto switch

● Number of auto switches

Nil	2
S	1
n	n

● Applicable Auto Switches/Refer to the [Web Catalog](#) or Best Pneumatics Catalog for further information on auto switches.

Type	Special function	Electrical entry	Indicator light	Wiring (Output)	Load voltage		Auto switch model		Lead wire length [m]				Pre-wired connector	Applicable load			
					DC	AC	Perpendicular	In-line	0.5 (Nil)	1 (M)	3 (L)	5 (Z)		IC circuit	Relay, PLC		
Reed auto switch	—	Grommet	Yes	3-wire (NPN equivalent)	—	5 V	—	A96V	A96	●	—	●	—	—	IC circuit	—	
				2-wire	24 V	12 V	100 V	A93V *1	A93	●	●	●	●	—	—	—	Relay, PLC
					—	—	100 V or less	A90V	A90	●	—	●	—	—	—	IC circuit	—

*1 The 1 m lead wire is only applicable to the D-A93.

* Lead wire length symbols: 0.5 m.....Nil (Example) A93
1 m.....M (Example) A93M
3 m.....L (Example) A93L
5 m.....Z (Example) A93Z

* Auto switches are shipped together, but not assembled.

7 Heat-resistant Specification (−10 to 100°C)

Symbol
-X2128

Seal material and grease have been changed so that the product can be used at temperatures between −10 up to 100°C.

MXJ Standard model no. – X2128

● Heat-resistant specification

- * Magnet is built-in, but when using an auto switch, the acceptable temperature range becomes −10 to 60°C.
- * It is not possible to order a model with an auto switch.
- * For lubrication, specialized grease GR-F is recommended.

Specifications

Ambient temperature	−10°C to 100°C (No freezing)
Seal material	Fluororubber
Grease	Heat-resistant grease
Applicable adjuster type	Metal stopper

* Specifications other than the above are the same as the standard type.

8 Low-speed Specification (15 to 50 mm/s)

Symbol
-X2410

Stick-slip phenomenon can be prevented, and smooth operation can be achieved even at lower driving speeds between 15 to 50 mm/s.

MXJ Standard model no. – X2410

● Low-speed specification

- * Operate without lubrication from a pneumatic system lubricator.

Specifications

Operating speed range (Average operating speed)	15 to 50 mm/s
Applicable adjuster type	Rubber stopper, Metal stopper

* Dimensions and specifications other than the above are the same as the standard type.

MXJ Series Model Selection

For Transfer

- (1) Load mass and overhang L_1 and L_2 , should be within the average speed (V_a) limit in the graphs.
- (2) For horizontal use, overhang L_3 should not exceed the allowable range.
For vertical use, it is not necessary to consider L_3 as it does not affect the moment.

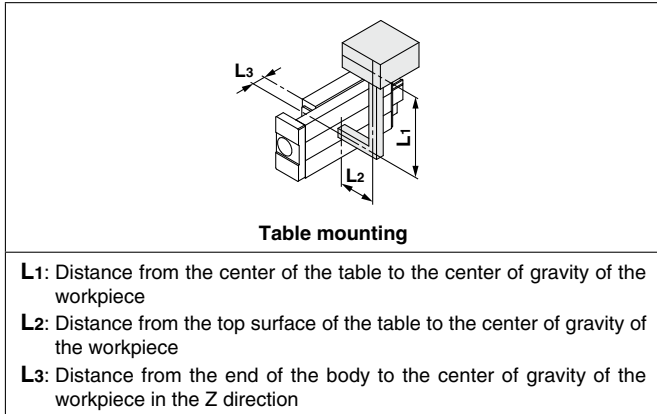

Please contact your SMC sales representative when using end plate mounting.

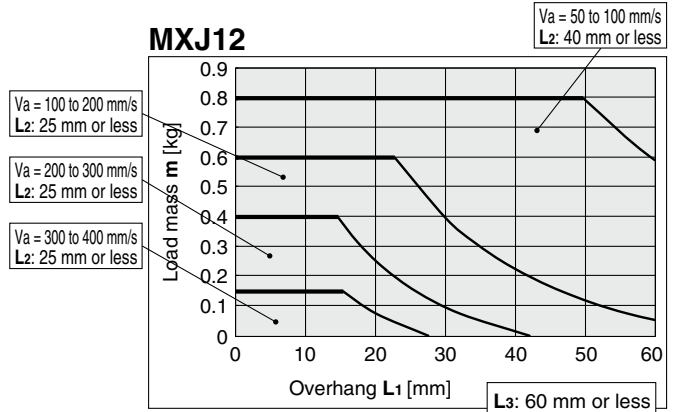

* Confirm that the overhang L_1 is within the allowable range based on the load mass and average speed.

⚠ Caution

If the operating speed is increased after setting the operating conditions such as overhang and operating speed, the stopping impact force will increase which causes an excessive moment to be generated; this will lead to the failure of the guide. Do not increase the operating speed after setting the operating conditions.

If the adjusting screw of the speed controller is loosened, the operating speed will increase, so the screw should be tightened completely.

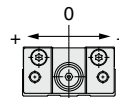
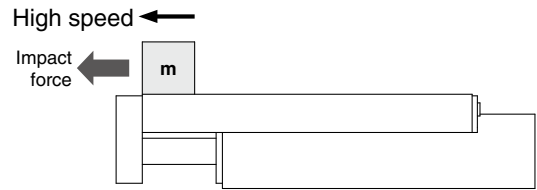

The allowable overhang L_1 for without adjuster type is symmetrical. Use in either direction.

Without Adjuster

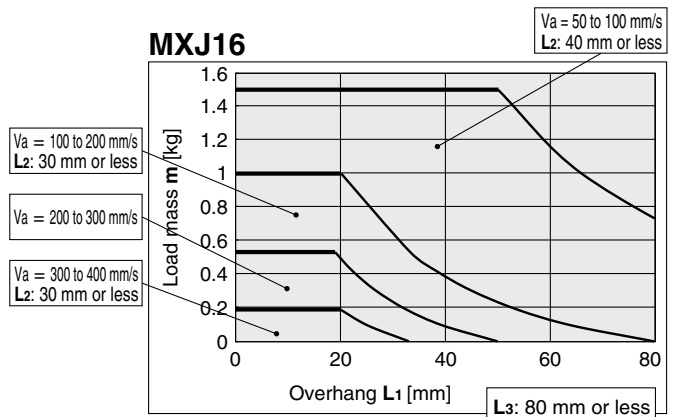
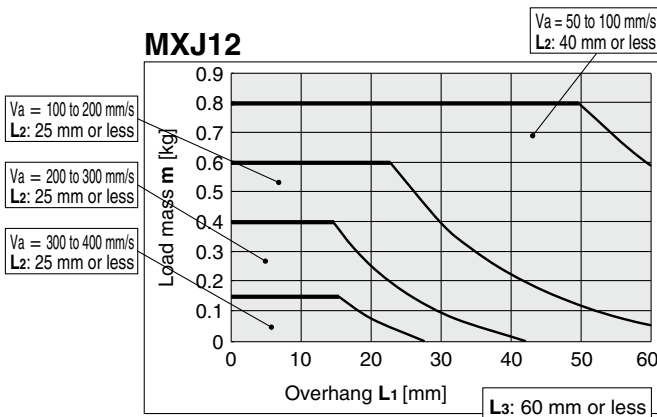

For Transfer

Metal Stopper with Bumper

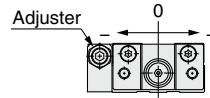

The allowable overhang L1 for adjuster type is asymmetrical. Adjuster side is the "-" direction.

MXJ12

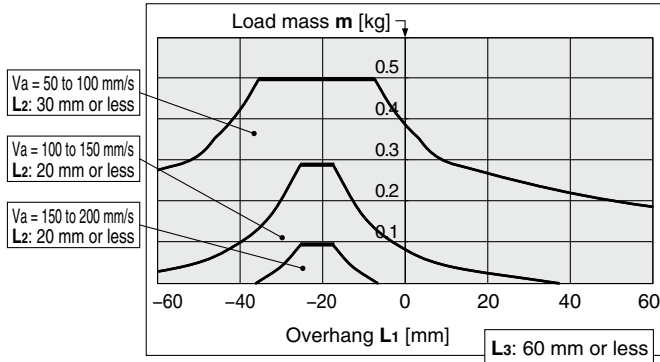

MXJ16

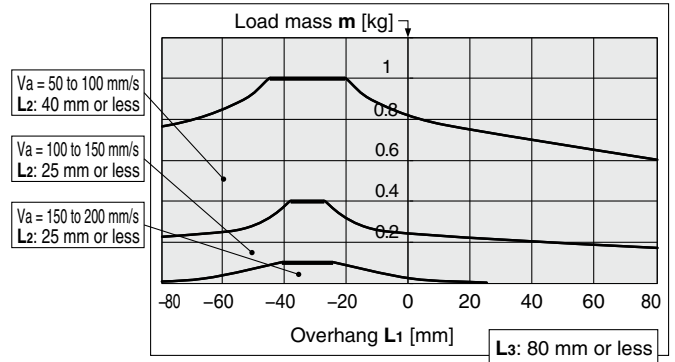

Rubber Stopper

MXJ12

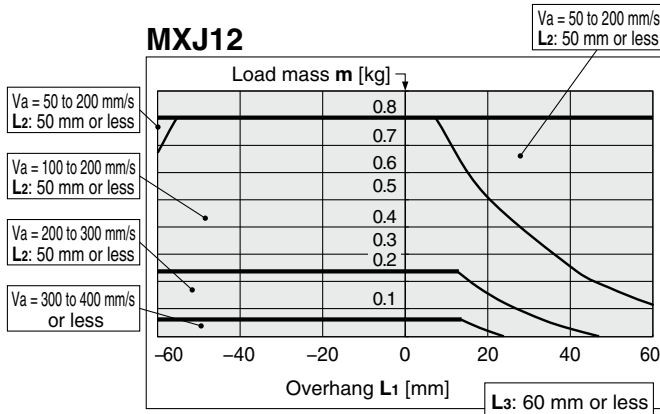

MXJ16

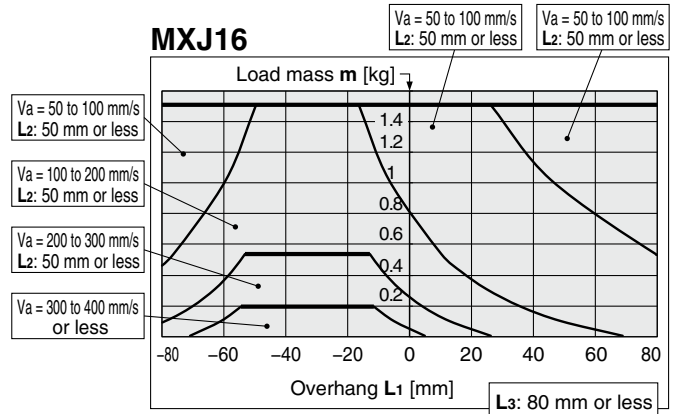

Shock Absorber (RJ)

MXJ12

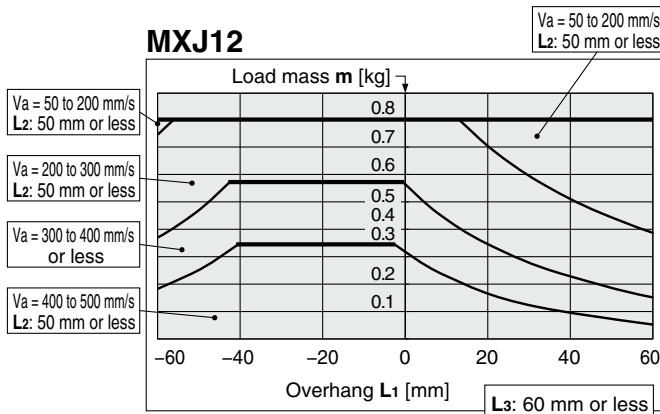

MXJ16

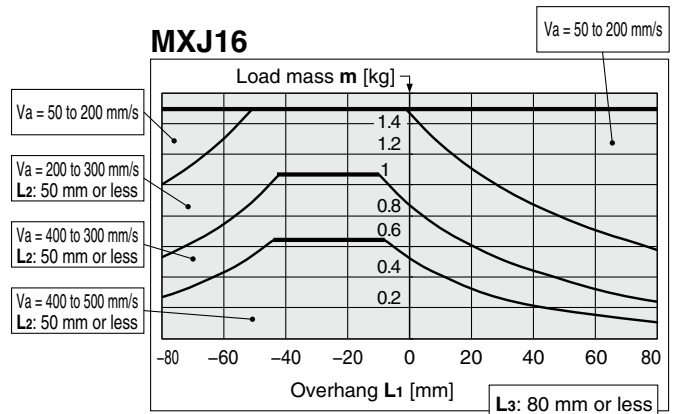

Metal Stopper

MXJ12

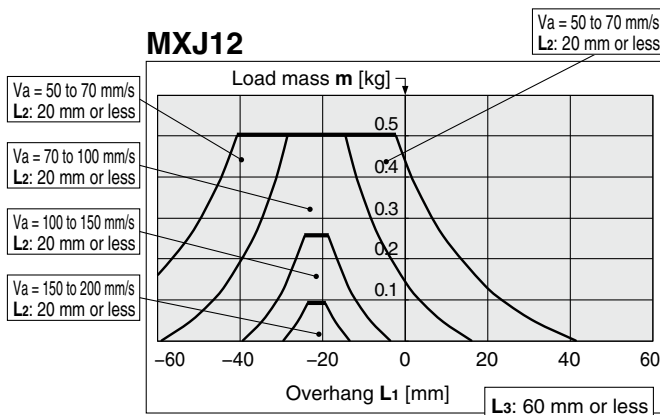

MXJ16

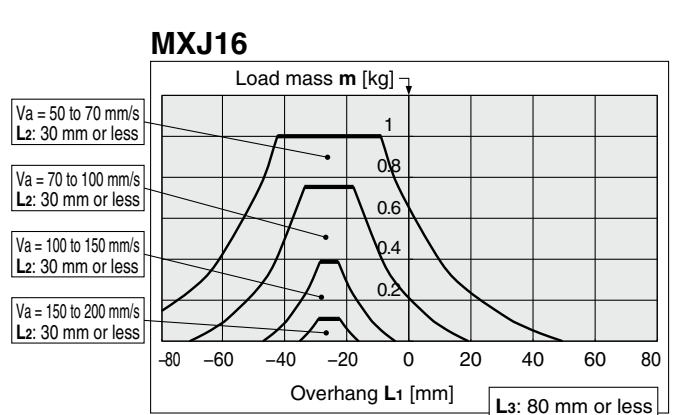

MXJ Series

For Pressing (Clamping)

- (1) Confirm that the clamping jig weight and overhang are within the allowable range as shown in the graphs for transfer. (▶ pp. 19, 20)
- (2) Pressing force N and overhang L_1 and L_2 , should be within the range as shown in the graphs.

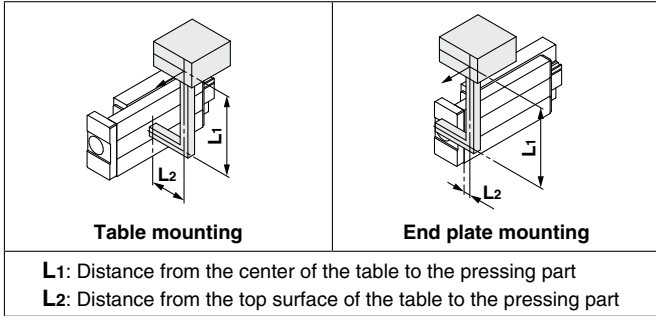

MXJ12

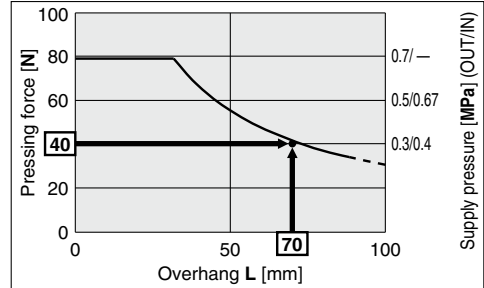

- * Allowable supply pressure on OUT side and IN side is the theoretical output of cylinder when pressing force is required.
- * Confirm that the intersection of the pressing force and overhang L_1 is within the range as shown in the graph.

Table Mounting

MXJ12

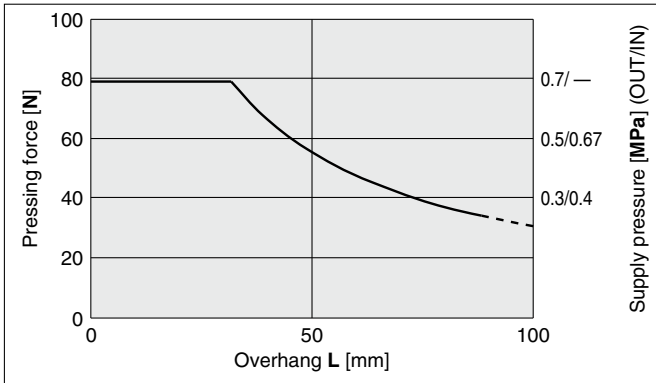

MXJ16

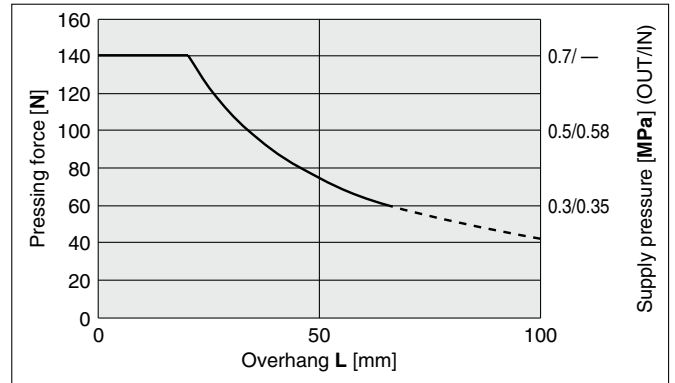

End Plate Mounting

MXJ12

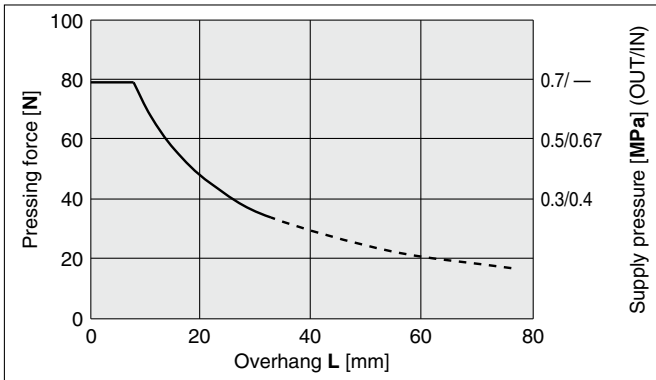

MXJ16

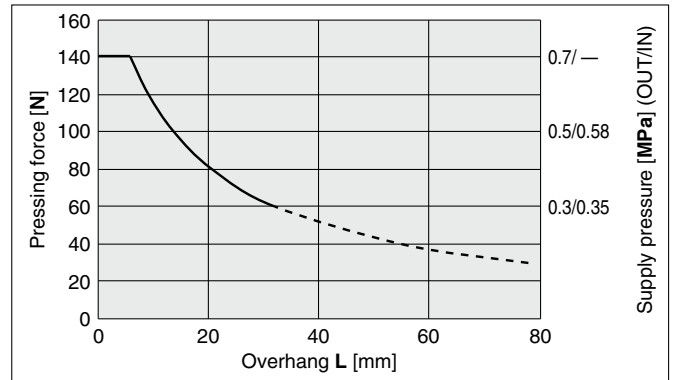

The graphs below show the table displacement when the static moment load is applied to the table. The graphs do not show the loadable mass. Refer to the Model Selection for the loadable mass.

Table Deflection (Reference Values)

Table displacement due to pitch moment load

Displacement when a load is applied to the part indicated by the arrow for the entire stroke

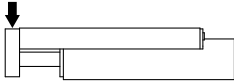

MXJ12

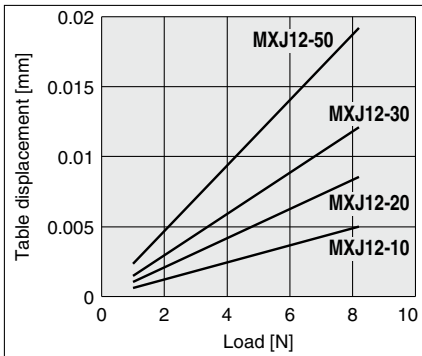

MXJ16

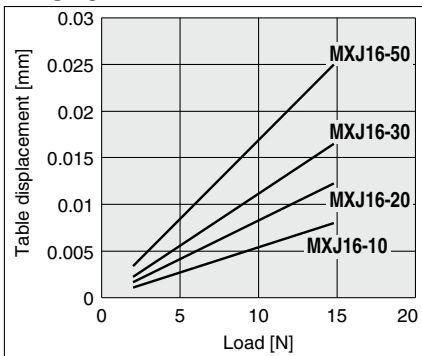
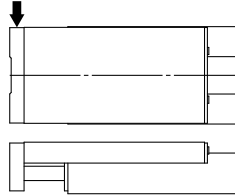
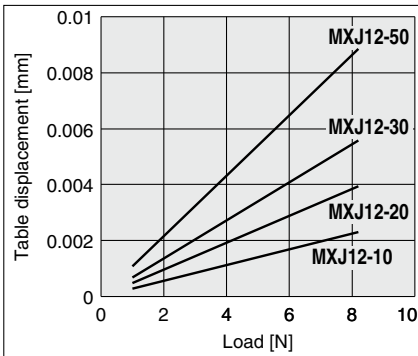

Table displacement due to yaw moment load

Displacement when a load is applied to the part indicated by the arrow for the entire stroke



MXJ12



MXJ16

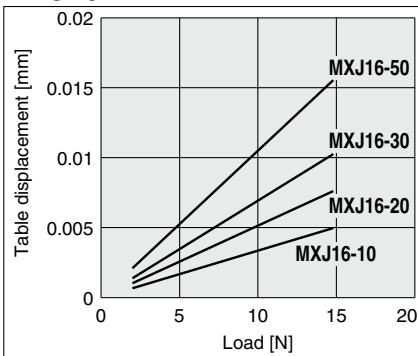
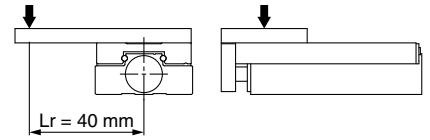
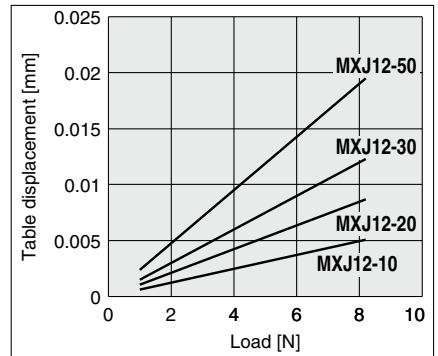

Table displacement due to roll moment load

Displacement when a load is applied to the part indicated by the arrow when the table is retracted



MXJ12



MXJ16

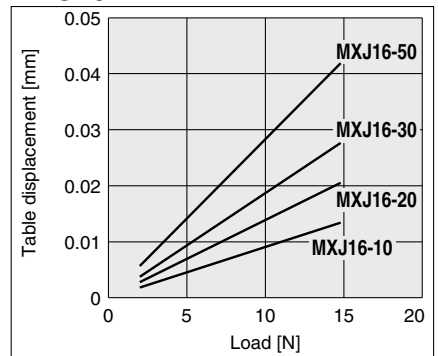



MXJ Series

Specific Product Precautions 1

Be sure to read this before handling the products. Refer to the back cover for safety instructions. For actuator and auto switch precautions, refer to the “Handling Precautions for SMC Products” and the “Operation Manual” on the SMC website: <https://www.smcworld.com>

Selection

⚠ Caution

1. Operate loads within the range of the operating limits.

Select the model considering maximum load mass and allowable moment. For details, refer to “Model Selection” on pages 19 to 22. When actuator is used outside of operating limits, eccentric loads on guide will be in excess of this causing vibration on guide, inaccuracy, and shortened life.

2. If an intermediate stop is performed by an external stopper, be careful of ejection.

If lurching occurs, damage can result. If a slide table is stopped at an intermediate position by an external stopper and then moved forwards, after the slide table is returned to the back to retract the stopper, supply pressure to the opposite port to operate the slide table.

3. Do not use the product in such a way that excessive external force or impact force is applied to it.

This could result in damage.

Mounting

⚠ Caution

1. Do not scratch or dent the mounting surface of the body, table, or end plate.

This can cause a loss of parallelism in the mounting surfaces, vibration in the guide unit, increased operating resistance, etc.

2. Do not scratch or dent the transfer surface of the rail or guide.

This could result in looseness, increased operating resistance, etc.

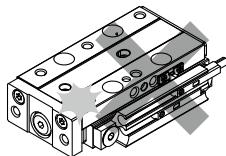

3. Do not apply excessive impact or loads when a workpiece is mounted.

If an external force over the allowable moment is applied, looseness of the guide unit or increased operating resistance may occur.

4. Flatness of mounting surface should be 0.02 mm or less.

Poor parallelism of the workpiece mounted on the body, the base, and other parts can cause vibration in the guide unit, increased operating resistance, etc.

5. Select the proper connection when connecting with a load which has external support and/or a guide mechanism on the outside, and align it properly.

6. Avoid contact with the body during operation.

Hands, etc., may get caught in the adjuster. Install a cover as a safety measure if there are instances when anyone will be near the slide table during operation.

Mounting

⚠ Caution

7. Keep away from objects which are influenced by magnets.

Since this product has a built-in magnet, do not allow close contact with magnetic disks, cards or tapes. Data may be erased.

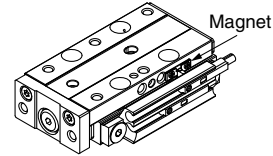

8. Do not touch a magnet to the body and table section.

Since the body and table are made from a magnetic substance, they could become magnetized if put in contact with a magnet, etc. This could cause auto switches, etc., to malfunction.

9. When mounting the workpiece with screws, refer to the table below for the tightening torques and use the appropriate length of screw.

Tightening with a torque above the limit could cause a malfunction. Whereas, tightening insufficiently could result in misalignment or dropping.

• Body mounting

1. Bottom mounting (Body tapped)

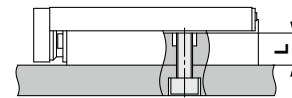

Model	Bolt	Tightening torque [N·m]	Max. screw-in depth L [mm]
MXJ12	M5 x 0.8	5.4	10
MXJ16	M5 x 0.8	5.4	12

2. Top mounting (Through hole)

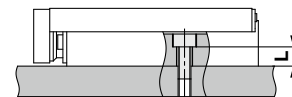

Model	Bolt	Tightening torque [N·m]	L [mm]
MXJ12	M4 x 0.7	2.7	6
MXJ16	M4 x 0.7	2.7	8

3. Side mounting (Body tapped)

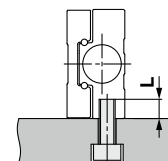

Model	Bolt	Tightening torque [N·m]	Max. screw-in depth L [mm]
MXJ12	M5 x 0.8	5.4	5
MXJ16	M5 x 0.8	5.4	5



MXJ Series

Specific Product Precautions 2

Be sure to read this before handling the products. Refer to the back cover for safety instructions. For actuator and auto switch precautions, refer to the "Handling Precautions for SMC Products" and the "Operation Manual" on the SMC website: <https://www.smcworld.com>

Mounting

⚠ Caution

• Workpiece mounting

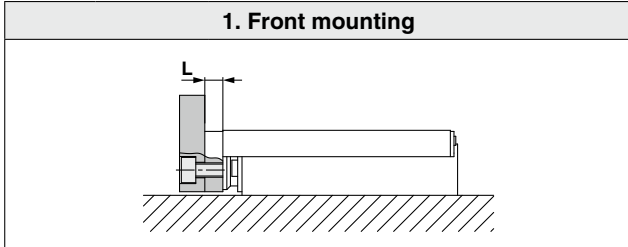

Model	Bolt	Tightening torque [N·m]	Max. screw-in depth L [mm]
MXJ12	M4 x 0.7	1.5	5
MXJ16	M4 x 0.7	1.5	6

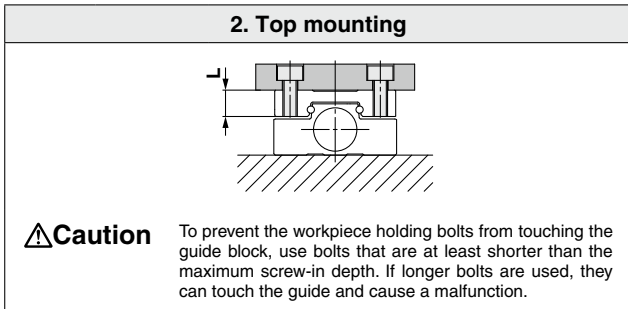

Model	Bolt	Tightening torque [N·m]	Max. screw-in depth L [mm]
MXJ12	M4 x 0.7	2.7	7
MXJ16	M4 x 0.7	2.7	9

10. When the adjuster is mounted, a moment is generated by the cylinder thrust, causing displacement of the table end at stop. The displacement amount may vary depending on the supply pressure, mounting orientation, or model. For details, please contact your SMC sales representative.

11. When using a metal stopper with bumper, use it at the minimum operating pressure level by taking the full compression force into consideration.

When using a metal stopper with bumper, the cylinder output decreases by the full compression of the bumper. If the output has no allowance, the bumper will not be fully compressed to the metal, causing the stop position to be unstable. When selecting a model, pay attention to the cylinder output. (Refer to the table below.)

In particular, when mounted upward in the vertical direction, not only the full compression force of the bumper, but also the workpiece mass should be taken into consideration.

- Horizontal: Cylinder output > Full compression force of bumper
- Vertical: Cylinder output > Full compression force of bumper + (Workpiece mass + Mass of product moving parts)

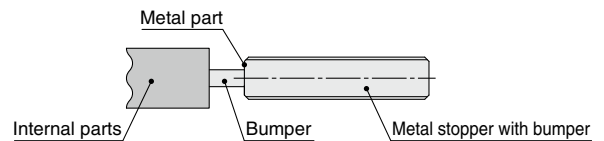

Model	Min. operating pressure of metal stopper with bumper [MPa]	Reference) Full compression force [N]
MXJ12	0.3	20
MXJ16	0.3	42

Precautions for metal stopper with bumper

Horizontal

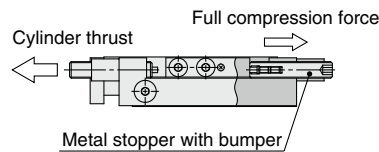

Vertical

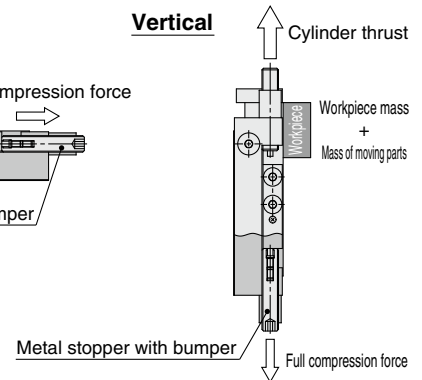



MXJ Series Specific Product Precautions 3

Be sure to read this before handling the products. Refer to the back cover for safety instructions. For actuator and auto switch precautions, refer to the "Handling Precautions for SMC Products" and the "Operation Manual" on the SMC website: <https://www.smcworld.com>

Mounting

⚠ Caution

12. Dimensions of parts for side mounting (and piping)

When mounting the adjuster type or switch rail type to the side, machine a groove for the air passage and "O" ring for sealing to the mounting plate.

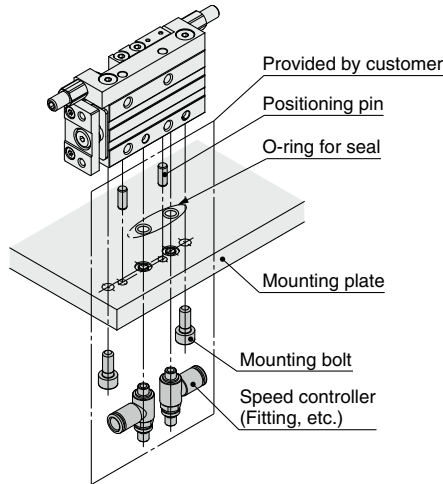

For MXJ12

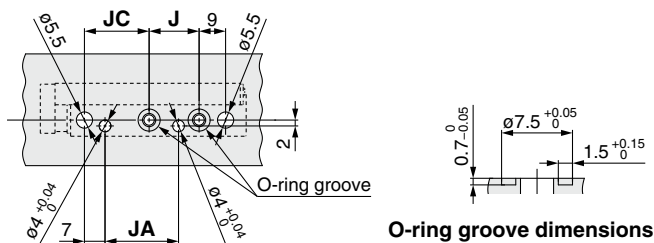

Model	JC	J	JA	Applicable O-ring
MXJ12-10Z	22	17	25	SS060 (SS standard, thickness $\phi 1 \times$ I.D. $\phi 6$)
MXJ12-20Z	14	27	27	
MXJ12-30Z	14	37	37	
MXJ12-50Z	14	57	57	

For MXJ16

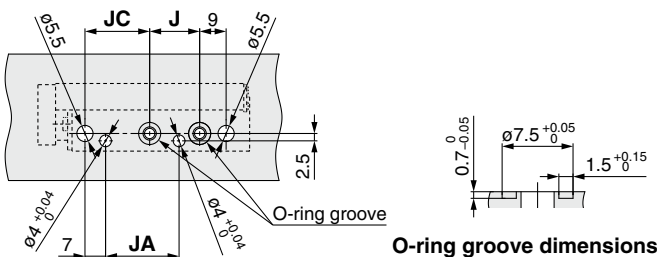

Model	JC	J	JA	Applicable O-ring
MXJ16-10Z	22	17	25	SS060 (SS standard, thickness $\phi 1 \times$ I.D. $\phi 6$)
MXJ16-20Z	16	27	29	
MXJ16-30Z	16	37	39	
MXJ16-50Z	16	57	59	

Mounting

⚠ Caution

13. Because the difference in width between the table and the body is very small, the table end may come into contact with the mounting surface.

Keep 1 mm or more clearance on the mounting surface within the stroke range of the table.

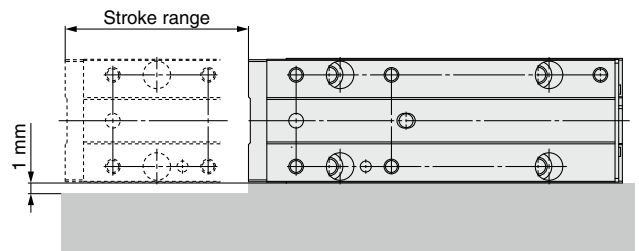

Operating Environment

⚠ Caution

1. Do not use in environments where the product could be exposed to liquids, such as cutting oil, etc.

Using in an environment where the product could be exposed to cutting oil, coolant, oil, etc., could result in looseness, increased operating resistance, air leakage, etc.

2. Do not use in environments where the product could be exposed directly to foreign matter, such as powder dust, blown dust, cutting chips, spatter, etc.

This could result in looseness, increased operating resistance, air leakage, etc. Please consult with SMC regarding use in this kind of environment.

3. Do not use in direct sunlight.

4. When there are heat sources in the surrounding area, block them off.

When there are heat sources in the surrounding area, radiated heat may cause the product's temperature to rise and exceed the operating temperature range. Block off the heat with a cover, etc.

5. Do not subject the product to excessive vibration and/or impact.

Please consult with SMC regarding use in this kind of environment, as this can cause damage or a malfunction.

6. Use caution for the anti-corrosiveness of the linear guide unit.

Martensitic stainless steel is used for the body and table. However, the anti-corrosiveness of this steel is inferior to that of austenitic stainless steel. In particular, rust may be generated in environments where waterdrops are likely to adhere due to condensation, etc.



MXJ Series

Specific Product Precautions 4

Be sure to read this before handling the products. Refer to the back cover for safety instructions. For actuator and auto switch precautions, refer to the “Handling Precautions for SMC Products” and the “Operation Manual” on the SMC website: <https://www.smcworld.com>

Caution on Handling Adjuster

⚠ Caution

1. Tighten the lock nut with the tightening torque shown below.

Insufficient torque will cause a decrease in the positioning accuracy.

Model	Thread size	Tightening torque [N·m]
MXJ12	M6 x 0.75	5
MXJ16	M8 x 1	12.5

Shock Absorber/RJ

Model	Thread size	Tightening torque [N·m]
MXJ12	M6 x 0.75	0.85
MXJ16	M8 x 1	1.67

2. When adjusting the adjuster, do not hit the table with a wrench, etc.

This could result in looseness.

Other

⚠ Warning

1. Do not put hands or fingers between the end plate and body.

Never put hands or fingers in the gap between the end plate and body when retracted. Doing so will result in injury to the hands, or fingers.

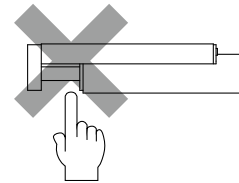

⚠ Caution

1. Do not disassemble or modify the product.
2. If the slide table is stopped at an intermediate position by external stopper, position of the steel balls that make up the liner guide may become displaced. When the intermediate stop is released while the steel ball position is displaced, the slide table may not be able to achieve a full stroke with minimum operating pressure. In this case, increase the supply pressure once up to the full stroke, then use the slide table with the specified pressure.
3. Performance stability
The piston speed in the specification table shows the average speed. The actual speed of this product may vary slightly during the stroke depending on the operating conditions, such as the change of load resistance and pressure. If a stable operation at low speed is necessary, please contact your local SMC sales office.
4. Be aware that smoking cigarettes, etc., after your hands have come into contact with the grease used in the cylinder section of this product can create a gas that is hazardous to humans.



MXJ Series Specific Product Precautions 5

Be sure to read this before handling the products. Refer to the back cover for safety instructions. For actuator and auto switch precautions, refer to the "Handling Precautions for SMC Products" and the "Operation Manual" on the SMC website: <https://www.smcworld.com>

Caution on Replacing Standard Type to Symmetric Type, and Vice Versa

The adjuster, switch rail, and port location can be changed symmetrically. (⇒ p. 28)

Component Parts

Body mounting section

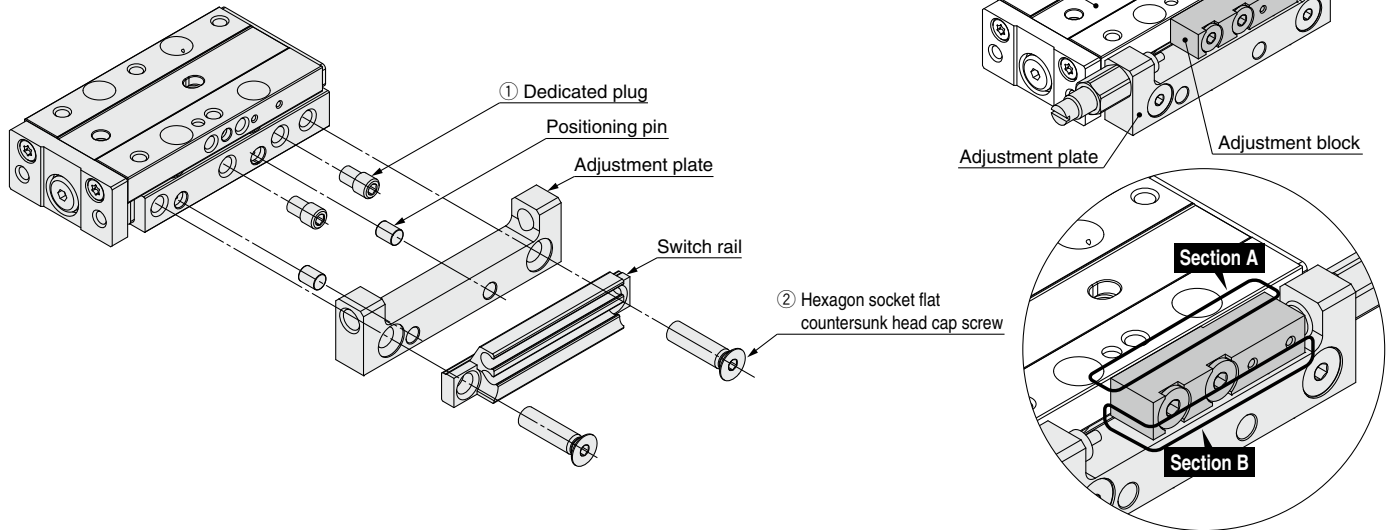
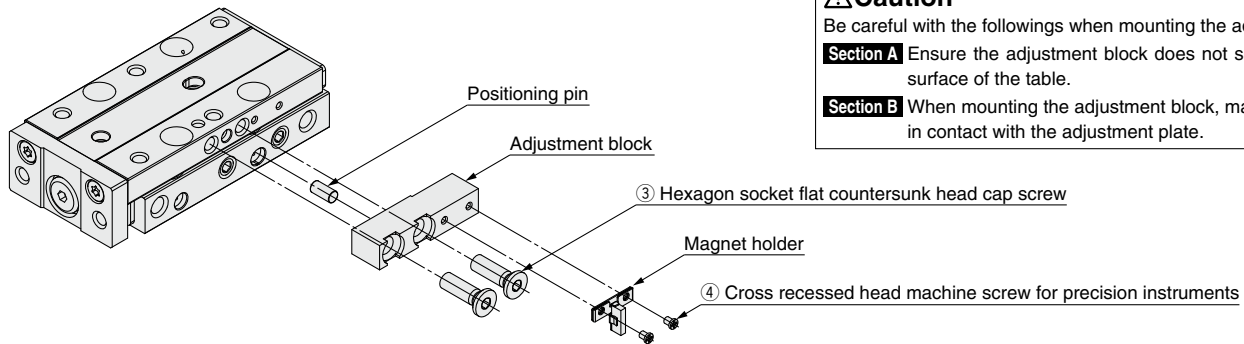

Table mounting section



Caution

Be careful with the followings when mounting the adjustment block.

Section A Ensure the adjustment block does not sit above the top surface of the table.

Section B When mounting the adjustment block, make sure it is not in contact with the adjustment plate.

* There are 3 types of hexagon socket flat countersunk head cap screw for ② below. The tightening torque is the same for all of them.

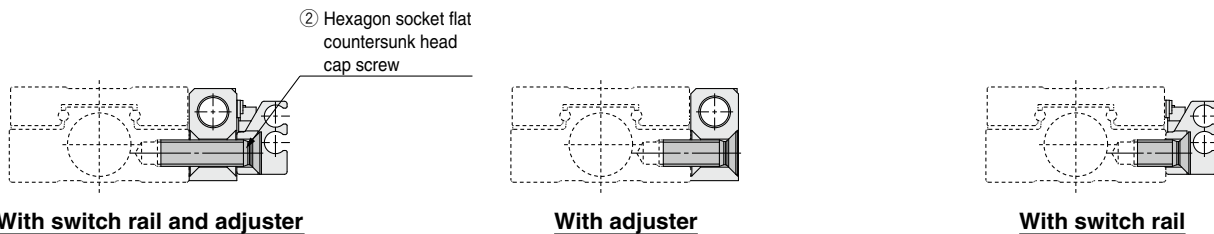

No.	Screw	Screw size	Tightening torque [N·m]
①	Dedicated plug*1	M5 x 0.8	2.0
②	Hexagon socket flat countersunk head cap screw	M5 x 0.8	3.4
③	Hexagon socket flat countersunk head cap screw	M4 x 0.7	3.4
④	Cross recessed head machine screw for precision instruments	M1.7 x 0.35	0.13

*1 No need to applying sealant to the dedicated plug when exchanging.



MXJ Series

Specific Product Precautions 6

Be sure to read this before handling the products. Refer to the back cover for safety instructions. For actuator and auto switch precautions, refer to the "Handling Precautions for SMC Products" and the "Operation Manual" on the SMC website: <https://www.smcworld.com>

Caution on Replacing Standard Type to Symmetric Type, and Vice Versa

⚠ Caution

Replace the parts by moving or rotating in the directions shown. Tighten with the torques specified in page 27 when reassembling the parts.

Adjustment plate

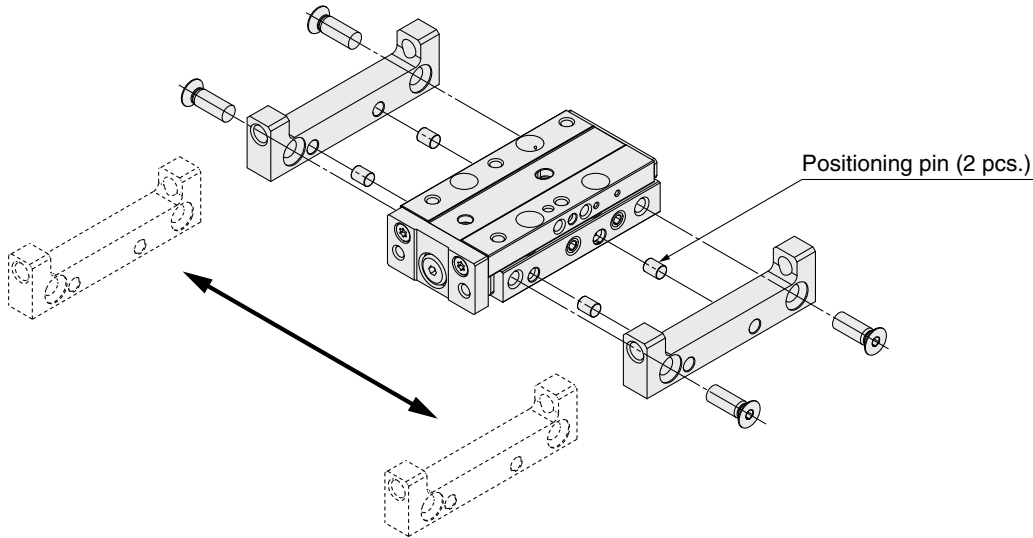

Adjustment block

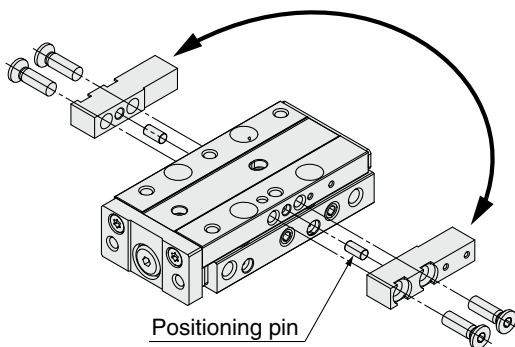

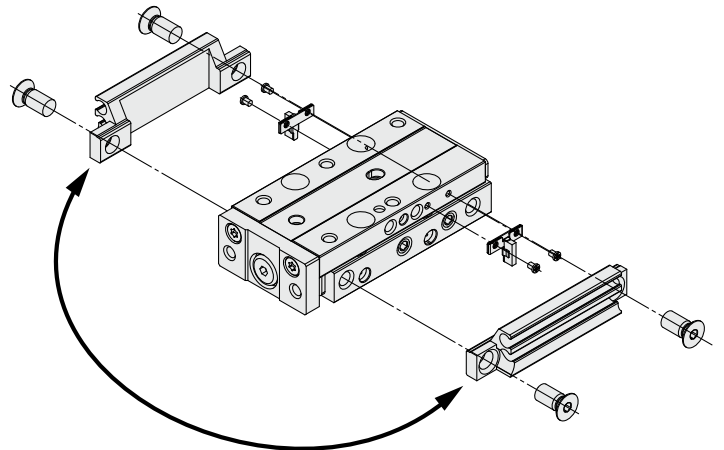

Switch rail



Safety Instructions

These safety instructions are intended to prevent hazardous situations and/or equipment damage. These instructions indicate the level of potential hazard with the labels of “**Caution**,” “**Warning**” or “**Danger**.” They are all important notes for safety and must be followed in addition to International Standards (ISO/IEC)*1), and other safety regulations.

 **Caution:** **Caution** indicates a hazard with a low level of risk which, if not avoided, could result in minor or moderate injury.

 **Warning:** **Warning** indicates a hazard with a medium level of risk which, if not avoided, could result in death or serious injury.

 **Danger :** **Danger** indicates a hazard with a high level of risk which, if not avoided, will result in death or serious injury.

*1) ISO 4414: Pneumatic fluid power – General rules relating to systems.
ISO 4413: Hydraulic fluid power – General rules relating to systems.
IEC 60204-1: Safety of machinery – Electrical equipment of machines.
(Part 1: General requirements)
ISO 10218-1: Manipulating industrial robots – Safety.
etc.

Warning

1. The compatibility of the product is the responsibility of the person who designs the equipment or decides its specifications.

Since the product specified here is used under various operating conditions, its compatibility with specific equipment must be decided by the person who designs the equipment or decides its specifications based on necessary analysis and test results. The expected performance and safety assurance of the equipment will be the responsibility of the person who has determined its compatibility with the product. This person should also continuously review all specifications of the product referring to its latest catalog information, with a view to giving due consideration to any possibility of equipment failure when configuring the equipment.

2. Only personnel with appropriate training should operate machinery and equipment.

The product specified here may become unsafe if handled incorrectly. The assembly, operation and maintenance of machines or equipment including our products must be performed by an operator who is appropriately trained and experienced.

3. Do not service or attempt to remove product and machinery/equipment until safety is confirmed.

1. The inspection and maintenance of machinery/equipment should only be performed after measures to prevent falling or runaway of the driven objects have been confirmed.
2. When the product is to be removed, confirm that the safety measures as mentioned above are implemented and the power from any appropriate source is cut, and read and understand the specific product precautions of all relevant products carefully.
3. Before machinery/equipment is restarted, take measures to prevent unexpected operation and malfunction.

4. Contact SMC beforehand and take special consideration of safety measures if the product is to be used in any of the following conditions.

1. Conditions and environments outside of the given specifications, or use outdoors or in a place exposed to direct sunlight.
2. Installation on equipment in conjunction with atomic energy, railways, air navigation, space, shipping, vehicles, military, medical treatment, combustion and recreation, or equipment in contact with food and beverages, emergency stop circuits, clutch and brake circuits in press applications, safety equipment or other applications unsuitable for the standard specifications described in the product catalog.
3. An application which could have negative effects on people, property, or animals requiring special safety analysis.
4. Use in an interlock circuit, which requires the provision of double interlock for possible failure by using a mechanical protective function, and periodical checks to confirm proper operation.

Caution

1. The product is provided for use in manufacturing industries.

The product herein described is basically provided for peaceful use in manufacturing industries.
If considering using the product in other industries, consult SMC beforehand and exchange specifications or a contract if necessary.
If anything is unclear, contact your nearest sales branch.

Limited warranty and Disclaimer/ Compliance Requirements

The product used is subject to the following “Limited warranty and Disclaimer” and “Compliance Requirements”.

Read and accept them before using the product.

Limited warranty and Disclaimer

1. The warranty period of the product is 1 year in service or 1.5 years after the product is delivered, whichever is first.*2)
Also, the product may have specified durability, running distance or replacement parts. Please consult your nearest sales branch.
2. For any failure or damage reported within the warranty period which is clearly our responsibility, a replacement product or necessary parts will be provided.
This limited warranty applies only to our product independently, and not to any other damage incurred due to the failure of the product.
3. Prior to using SMC products, please read and understand the warranty terms and disclaimers noted in the specified catalog for the particular products.

*2) Vacuum pads are excluded from this 1 year warranty.

A vacuum pad is a consumable part, so it is warranted for a year after it is delivered.
Also, even within the warranty period, the wear of a product due to the use of the vacuum pad or failure due to the deterioration of rubber material are not covered by the limited warranty.

Compliance Requirements

1. The use of SMC products with production equipment for the manufacture of weapons of mass destruction (WMD) or any other weapon is strictly prohibited.
2. The exports of SMC products or technology from one country to another are governed by the relevant security laws and regulations of the countries involved in the transaction. Prior to the shipment of a SMC product to another country, assure that all local rules governing that export are known and followed.

Caution

SMC products are not intended for use as instruments for legal metrology.

Measurement instruments that SMC manufactures or sells have not been qualified by type approval tests relevant to the metrology (measurement) laws of each country. Therefore, SMC products cannot be used for business or certification ordained by the metrology (measurement) laws of each country.

Safety Instructions

Be sure to read the “Handling Precautions for SMC Products” (M-E03-3) and “Operation Manual” before use.