



Air Cylinder

Series *NCQ2/CQ2*

Compact Cylinder



Compact
Light Weight
Space Saving
15 Bore Sizes
Auto Switch Capability on 4 sides



Key Features

- Multiple methods of Product Selection
- Part Number Validation
- Preview and Download 2D & 3D CAD Models Online with Real-time Updating
- Save Parts into a Custom Parts List
- Email Parts Lists to Internal Groups (Purchasing, Maintenance) or External (Partner Companies, SMC Sales Representatives)

Select a Product, Your Way



- Explore Products by Category by Clicking "Get Started"
- Use "Browse Catalog" for Visual Product Selection
- Enter a Part Number or Partial Part Number



Render & Update 2D & 3D CAD Models in Real-Time



- View and Download 2D & 3D CAD Models
- Files Available in Multiple Formats, including SolidWorks, Catia, and others, compatible with Virtually any CAD System
- CAD Model will match the Part you have Designed and Validated
- CAD File can be Saved or Placed Directly into your Project Design

Validate Your Part Number

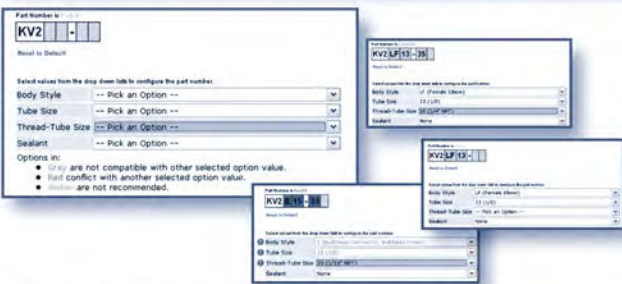

- Design a Custom Part Easily and Accurately with E-Tech's Part Number Validation
- Allows user to Build Part Numbers by Choosing Options through a Series of Pull-Downs
- E-Tech lets you know if a Part is Incomplete or Incompatible by Flagging it as either "Partial" or "Invalid"

Save & Send Custom Parts



- Click "Save Part" and add your newly Designed and Validated Part to your Favorites List
- Email Part to Co-Workers or Send it to your SMC Representative for a Quote

ENGINEERING | INNOVATION



Compact Cylinder

Series NCQ2 / CQ2



Remodeled with a new body for greater flexibility.

Lighter Weight

Reduced by **5 to 13%**
(Compared with SMC CQ2 series)

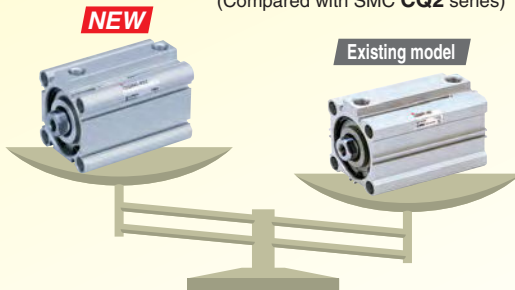

Body strength is the same as the existing product.
(kinetic energy, allowable load, withstand pressure, etc.)

Contribution to environment and ecology



Reduction of CO₂ discharge (**1300 tons less**)
by reduced use of aluminum

Example of Weight Advantage

		NEW CQ2	Previous CQ2
Bore ø40mm Stroke 50mm with built-in magnet and rubber bumper	female thread	456	483
	male thread	483	527

(g)

Small Auto Switch

2-Color indication solid state auto switch

Makes it easier to set the mounting position accurately.



The green light indicates **optimum operating range**.

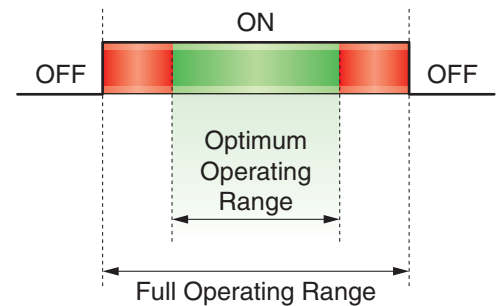

Even with 2-color indication solid state auto switches fixed at the optimum operating range (the green light lights up), operation may become unstable depending on the installation environment or magnetic field disturbance. (Magnetic body, external magnetic field, proximal installation of cylinders with built-in magnet and actuators, temperature change, other factors for magnetic force fluctuation during operation, etc.)

Simple Installation

1 Insert the auto switch.

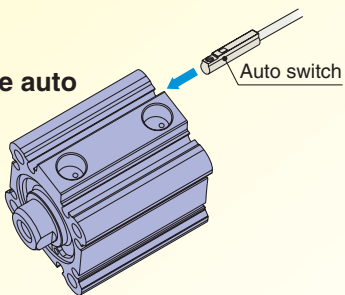

2 Fix the auto switch.

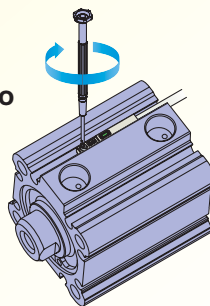

- Fewer components
- No loose parts to fall out

Flexibility in Mounting Auto Switches

ø32 to ø200

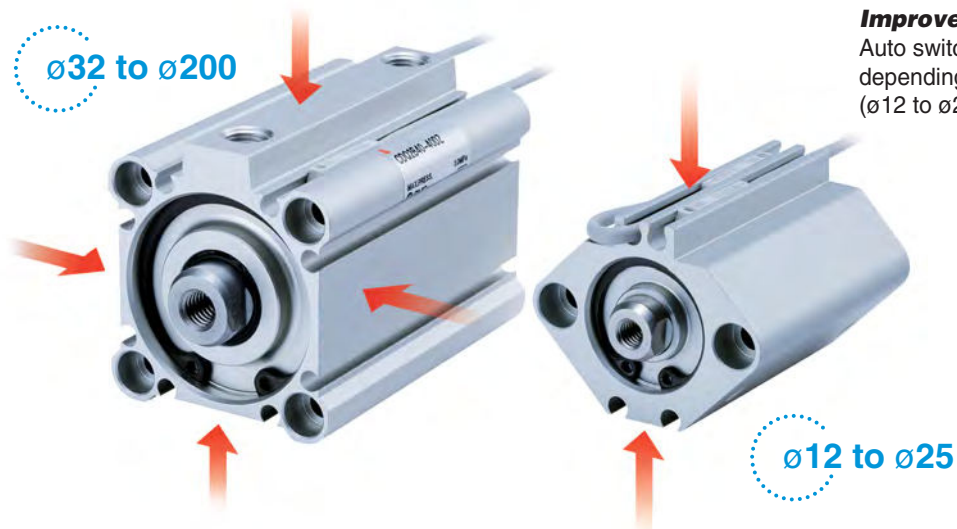

Improved flexibility of system design.

Auto switches can be mounted on any of the 4 surfaces, depending on the installation conditions. (ø12 to ø25: 2 surfaces, ø12: One slot for each surface)

Available up to **ø200**

ø12 to ø25

A round slot for mounting small auto switches is provided on 4 surfaces. Auto switch mounting rail has been removed.

Switch Slots Unblocked by Foot Brackets

The auto switch can be replaced with the foot brackets mounted.

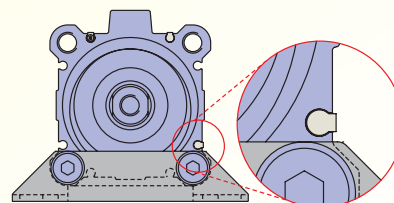
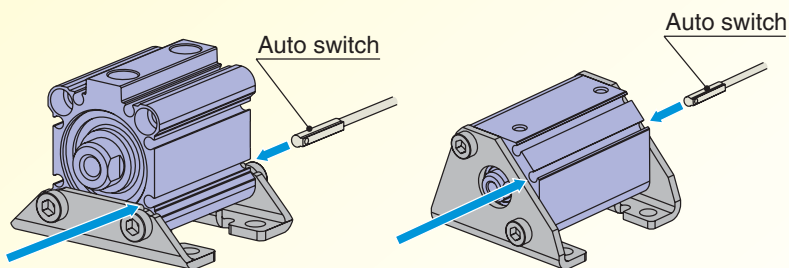

The bracket does not interfere with the slot.

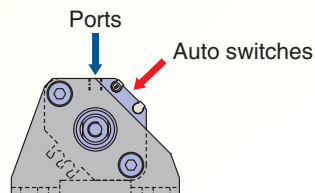

Ports and auto switch slots are adjacent for easy handling.

Rail Mounted Auto Switches can be Used

Refer to catalog ES20-205 for further information on auto switch mounting bracket.

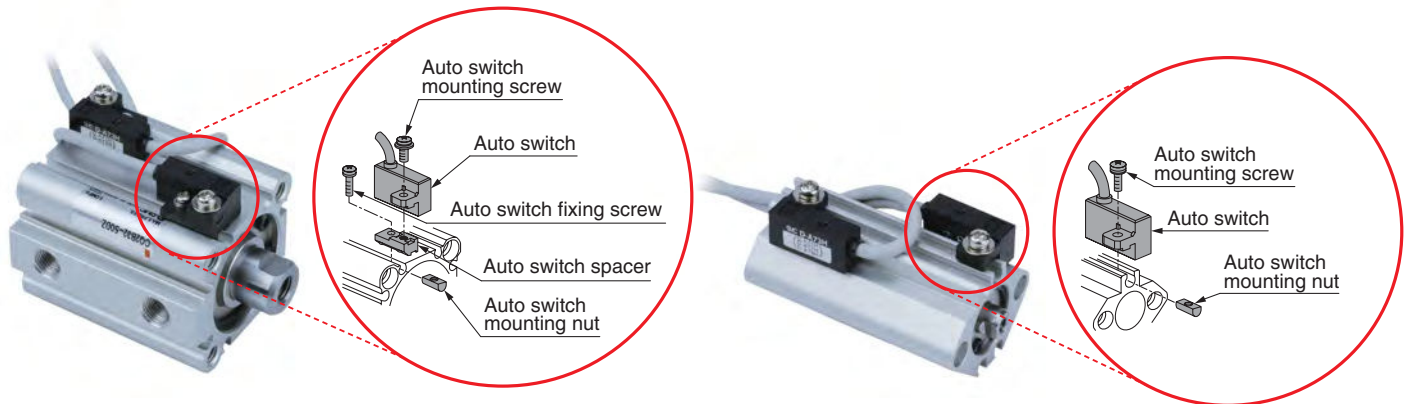

Shorter Delivery Times for Many Intermediate Stroke Cylinders

Exclusive bodies (-XB10) for $\varnothing 32$ to $\varnothing 100$ intermediate strokes (50 st or more) now kept in inventory. These were formerly produced upon receipt of order.

Intermediates in stock - bore $\varnothing 32$ to $\varnothing 100$

Stroke	50	55	60	65	70	75	80	85	90	95	100	
	Std.	intermediate strokes Currently stocked					Std.	intermediate strokes Currently stocked				Std.

Special Switch Types Available

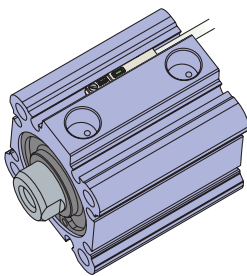

D-M9□W(V)

Standard

For general environments

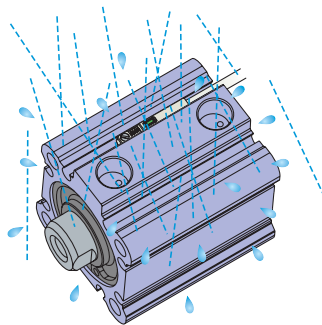

D-M9□A(V)

Water resistant type

For exposure to water and coolant

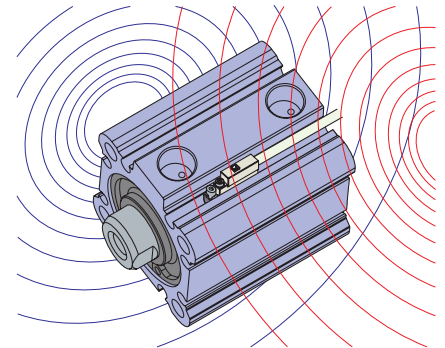

D-P3DW

Magnetic field resistant type

For use with AC spot welders, which generate strong magnetic fields

SMC's Global Engineering Network

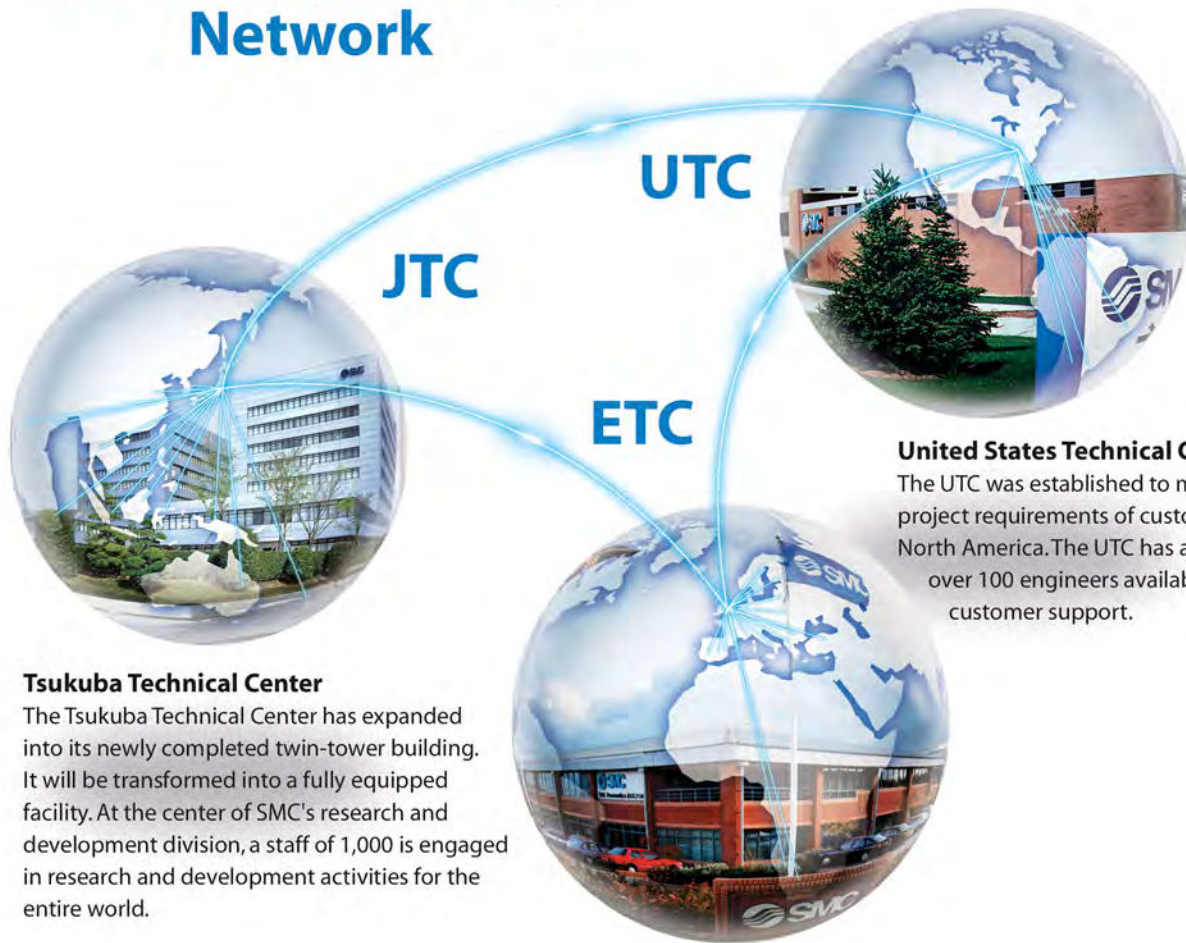

Tsukuba Technical Center

The Tsukuba Technical Center has expanded into its newly completed twin-tower building. It will be transformed into a fully equipped facility. At the center of SMC's research and development division, a staff of 1,000 is engaged in research and development activities for the entire world.

United States Technical Center

The UTC was established to meet the project requirements of customers in North America. The UTC has a staff of over 100 engineers available for customer support.

European Technical Center

The ETC has been established in the existing SMC UK factory site in Milton Keynes. Here, approximately 100 engineers from SMC European subsidiaries are gathered to handle projects from their respective countries. This has improved communication through faster and more accurate information being shared and this results in a higher level of customer satisfaction.



Global Products, Local Support

(N)CQ2 Compact Cylinder

series	type		page
(N)CQ2(K)	Standard	Double acting	2
		Large bore	
		Long stroke	
(N)CQ2 [§]	Standard	Non-rotating rod	31
		Single acting	
(N)CQ2W	Double Rod	Standard	49
(N)CQ2KW		Non-rotating rod	67
CQP2	Axial Piping	Double acting	77
CQP2 [§]		Single acting	83
CQ2 [¶]	Water Resistant		91
CQ2□S	High Lateral Load		103
CBQ2	End Lock		113
10-C□Q2	Clean Series		121
20-C□Q2	Copper and Fluorine-free		122

Additional Components and Information

Construction and Parts	125
Warranty and Operating Instructions	150
Mounting Bolts	155
Mounting Brackets	177
Auto Switches	181
Made to Order	216

Standard

Single Acting

Double Rod

Axial Piping

Water Resistant

High Lateral Load

End Lock

Clean Series

Copper/Fluorine free series

Construction and Parts

Warranty and Operating Instructions

Mounting and Auto Switches

Made to Order

Series (N)CQ2 Double Acting, Single Rod

Ordering Information

How to Order

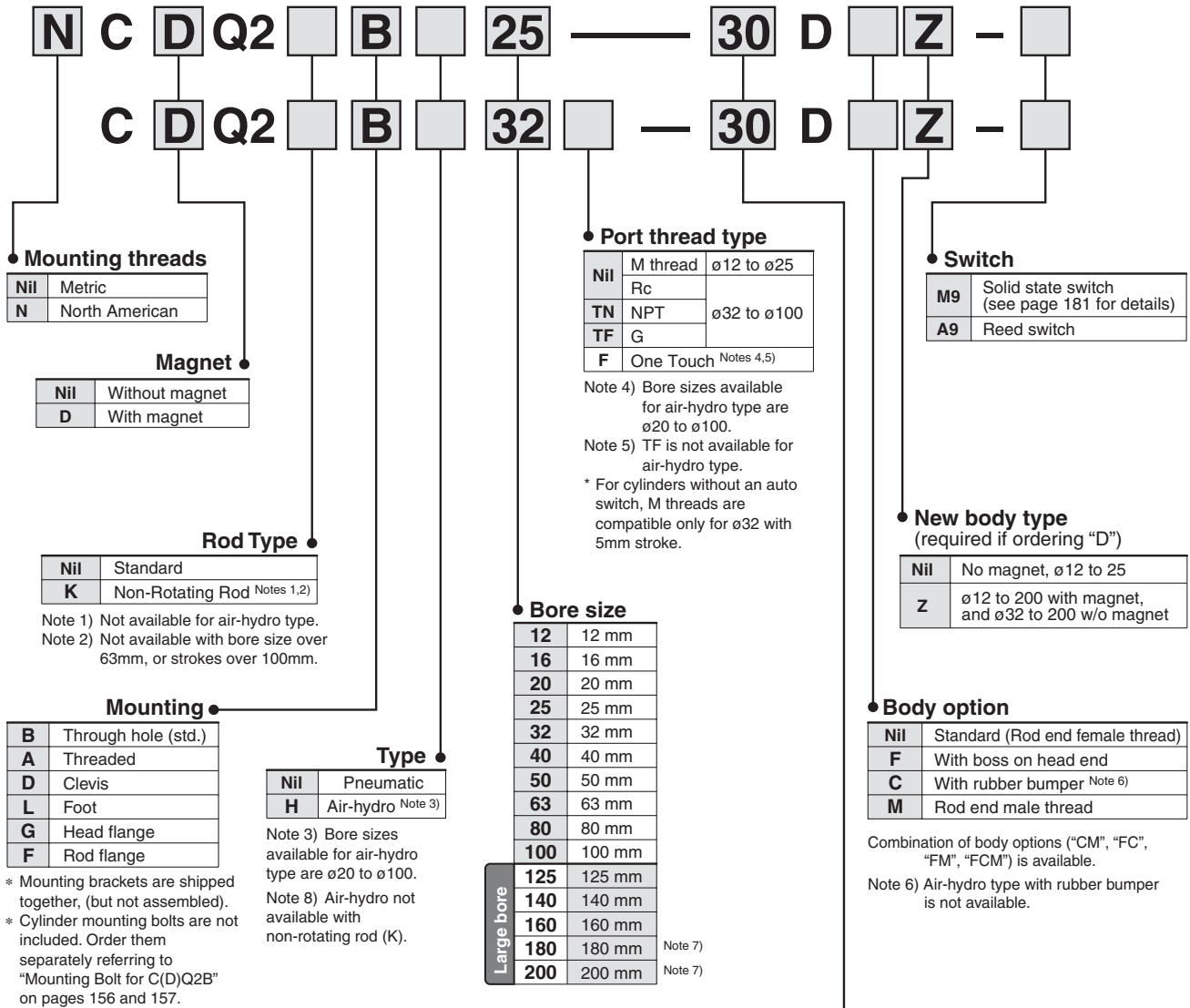

Bore	Stroke standard (pneumatic)										Long stroke							
	5	10	15	20	25	30	35	40	45	50	75	100	125	150	175	200	250	300
12	●	●	●	●	●	●												
16	●	●	●	●	●	●												
20	●	●	●	●	●	●	●	●	●	●								
25	●	●	●	●	●	●	●	●	●	●								
32	●	●	●	●	●	●	●	●	●	●	●	●	●	●	●	●	●	●
40	●	●	●	●	●	●	●	●	●	●	●	●	●	●	●	●	●	●
50		●	●	●	●	●	●	●	●	●	●	●	●	●	●	●	●	●
63		●	●	●	●	●	●	●	●	●	●	●	●	●	●	●	●	●
80		●	●	●	●	●	●	●	●	●	●	●	●	●	●	●	●	●
100		●	●	●	●	●	●	●	●	●	●	●	●	●	●	●	●	●
125		●		●		●		●		●	●	●	●	●	●	●	●	●
140		●		●		●		●		●	●	●	●	●	●	●	●	●
160		●		●		●		●		●	●	●	●	●	●	●	●	●
180		●		●		●		●		●	●	●	●	●	●	●	●	●
200		●		●		●		●		●	●	●	●	●	●	●	●	●

● Standard stroke

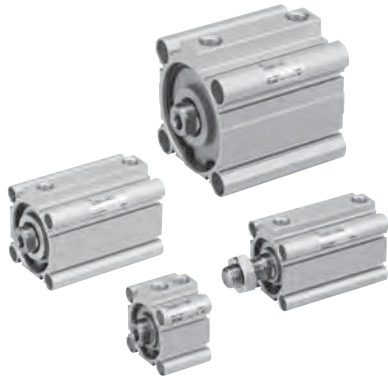

Symbol
Double acting,
Single rod

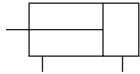

Symbol
With boss on
head end

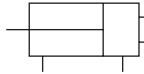

Symbol
Non-rotating rod

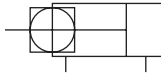

Specifications

Pneumatic

Bore size (mm)		12	16	20	25	32	40	50	63	80	100
Action		Double acting, Single rod									
Fluid		Air									
Proof pressure		218 psi (1.5 MPa)									
Maximum operating pressure		145 psi (1.0 MPa)									
Minimum operating pressure		10.2 psi (0.07 MPa)		7.3 psi (0.05 MPa)							
Ambient and fluid temperature		Without auto switch: -10 to 70°C (No freezing) With auto switch: -10 to 60°C (No freezing)									
Lubrication		Not required (Non-lube)									
Piston speed		50 to 500 mm/s									
Allowable kinetic energy (J)	Standard	0.022	0.038	0.055	0.09	0.15	0.26	0.46	0.77	1.36	2.27
	W/rubber bumper	0.043	0.075	0.11	0.18	0.29	0.52	0.91	1.54	2.71	4.54
	Long Stroke	-	-	-	-	0.29	0.52	0.91	1.54	2.71	4.54
Stroke length tolerance		+1.0 mm Note) +0									
Stroke length tolerance (long stroke)		+1.4 mm Note) 0									
(N)CQ2K Rod Non-rotating accuracy		±2°		±1°			±0.8°				

Note) Stroke length tolerance does not include the amount of bumper change.

Air-hydro

Bore size (mm)		20	25	32	40	50	63	80	100
Action		Double acting, Single rod							
Fluid		Turbine oil Note)							
Proof pressure		218 psi (1.5 MPa)							
Maximum operating pressure		145 psi (1.0 MPa)							
Minimum operating pressure		10.2 psi (0.18 MPa)				14.5 psi (0.1 MPa)			
Ambient and fluid temperature		5 to 60°C							
Piston speed		5 to 50 mm/s							
Cushion		None							
Stroke length tolerance		+1.0 mm +0							

Note) Refer to "Handling Precautions for SMC Products" (M-E03-3) for Actuator Precautions (5).

Specifications

Bore size (mm)		125	140	160	180	200
Action		Double acting, Single rod				
Fluid		Air				
Proof pressure		218 psi (1.5 MPa)			152 psi (1.05 MPa)	
Maximum operating pressure		145 psi (1.0 MPa)			102 psi (0.7 MPa)	
Minimum operating pressure		73 psi (0.05 MPa)				
Ambient and fluid temperature		Without auto switch: -10 to 70°C (No freezing) With auto switch: -10 to 60°C (No freezing)				
Lubrication		Not required (Non-lube)				
Piston speed		50 to 500 mm/s			20 to 400 mm/s	
Allowable kinetic energy (J)		7.4	9.8	12.4		
Stroke length tolerance		+1.4 mm Note) 0				

Note) Stroke length tolerance does not include the amount of bumper change.

Conversions

°F = 1.8°C + 32 1 J = 0.738 ft-lb
1 MPa = 145 psi 1 mm = 0.039 in



Manufacture of Intermediate Strokes

Type	A spacer is installed in the standard stroke body.		Exclusive body (-XB10)	
Part no.	Refer to "How to Order" for the standard model number. (P. 2)		Suffix "-XB10" to the end of standard model number. (P. 2)	
Description	Strokes in 1 mm intervals are available by installing a spacer in the standard stroke cylinder.		Strokes in 1 mm intervals are available by using an exclusive body with the specified stroke.	
Stroke range	Bore size	Stroke range	Bore size	Stroke range
	32 to 200	101 to 299	32 to 160	101 to 299
Example	Part no.: CQ2A50-166DCZ CQ2B50-175DCZ with 9 mm width spacer inside The B dimension is 230.5 mm.		Part no.: CQ2B50-166DCZ-XB10 Makes 166 mm stroke tube. The B dimension is 221.5 mm.	

Refer to pages 188 to 194 for the specifications of cylinders with autoswitches.

Theoretical Output



(N)

Bore size (mm)	Operating direction	Operating pressure (MPa)		
		0.3	0.5	0.7
12	IN	25	42	59
	OUT	34	57	79
16	IN	45	75	106
	OUT	60	101	141
20	IN	71	118	165
	OUT	94	157	220
25	IN	113	189	264
	OUT	147	245	344
32	IN	181	302	422
	OUT	241	402	563
40	IN	317	528	739
	OUT	377	628	880
50	IN	495	825	1150
	OUT	589	982	1370
63	IN	841	1400	1960
	OUT	935	1560	2180
80	IN	1360	2270	3170
	OUT	1510	2510	3520
100	IN	2140	3570	5000
	OUT	2360	3930	5500
125	IN	3376	5627	7878
	OUT	3682	6136	8590
140	IN	4313	7188	10063
	OUT	4618	7697	10776
160	IN	5655	9425	13195
	OUT	6032	10053	14074
180	IN	7257	12095	16933
	OUT	7634	12724	17813
200	IN	9048	15080	21112
	OUT	9425	15708	21991

1N = 0.2248 lbf

Technical Information - Standard, and with Non-Rotating Rod

Weight - Standard

Without Auto Switch (g)

Bore size (mm)	Cylinder stroke (mm)											
	5	10	15	20	25	30	35	40	45	50	75	100
12	29	35	41	47	54	60	—	—	—	—	—	—
16	42	50	59	67	76	84	—	—	—	—	—	—
20	63	75	88	101	114	127	140	152	165	178	—	—
25	86	100	115	129	144	158	173	187	202	216	—	—
32	125	145	165	184	204	224	244	263	283	303	448	547
40	187	208	230	251	273	294	315	337	358	380	552	664
50	—	339	372	405	438	471	504	537	570	603	872	1043
63	—	480	518	556	594	632	670	708	746	784	1112	1308
80	—	916	976	1036	1097	1157	1217	1277	1338	1398	1917	2215
100	—	1608	1688	1768	1849	1929	2010	2090	2170	2251	2982	3391

Additional Weight (g)

Bore size (mm)		12	16	20	25	32	40	50	63	80	100
Both ends tapped		2	2	6	6	6	6	6	19	45	45
Rod end male thread	Male thread	1.5	3	6	12	26	27	53	53	120	175
	Nut	1	2	4	8	17	17	32	32	49	116
With boss on head end		0.7	1.3	2	3	5	7	13	25	45	96
With rubber bumper		0	0	-2	-3	-3	-7	-9	-18	-31	-56
Built-in one-touch fittings		—	—	—	—	12	12	21	21	—	—
Foot (Including mounting bolts)		55	67	164	186	142	154	243	317	683	1052
Rod flange (Incl. mounting bolts)		57	69	139	161	180	214	373	559	1056	1365
Head flange (Incl. mounting bolts)		54	65	133	152	165	198	348	534	1017	1309
Double clevis (Including pin, retaining rings, bolts)		32	39	88	123	151	196	393	554	1109	1887

With Auto Switch (g)

Bore size (mm)	Cylinder stroke (mm)											
	5	10	15	20	25	30	35	40	45	50	75	100
12	43	49	55	61	67	73	—	—	—	—	—	—
16	64	71	79	87	95	102	—	—	—	—	—	—
20	94	106	118	131	143	155	167	179	191	203	—	—
25	134	149	164	180	195	210	226	241	256	272	—	—
32	182	202	222	241	261	281	300	320	340	359	459	558
40	269	290	312	333	355	376	398	420	441	463	575	687
50	—	455	488	521	554	587	620	653	686	719	891	1062
63	—	627	665	703	741	779	817	855	893	931	1129	1326
80	—	1162	1222	1282	1342	1403	1463	1524	1584	1644	1941	2237
100	—	1966	2047	2127	2208	2288	2368	2449	2529	2610	3018	3426

Additional Weight (g)

Bore size (mm)		12	16	20	25	32	40	50	63	80	100
Both ends tapped		1	1	3	3	6	6	6	19	45	45
Rod end male thread	Male thread	1.5	3	6	12	26	27	53	53	120	175
	Nut	1	2	4	8	17	17	32	32	49	116
With boss on head end		0.7	1.3	2	3	5	7	13	25	45	96
With rubber bumper		0	0	-2	-3	-3	-7	-9	-18	-31	-56
Built-in one-touch fittings		—	—	—	—	12	12	21	21	—	—
Foot (Including mounting bolts)		49	62	147	169	142	154	243	317	683	1052
Rod flange (Incl. mounting bolts)		54	67	131	153	180	214	373	559	1056	1365
Head flange (Incl. mounting bolts)		52	63	124	144	165	198	348	534	1017	1309
Double clevis (Including pin, retaining rings, bolts)		29	35	78	114	151	196	393	554	1109	1887

Weight - Non-Rotating Rod

Without Auto Switch (g)

Bore size (mm)	Cylinder stroke (mm)											
	5	10	15	20	25	30	35	40	45	50	75	100
12	60	67	74	81	88	95	—	—	—	—	—	—
16	58	67	76	85	94	103	—	—	—	—	—	—
20	103	117	131	145	159	173	187	201	215	229	—	—
25	137	152	167	182	197	212	227	242	257	272	—	—
32	196	215	234	253	272	291	310	329	347	366	506	601
40	205	226	248	269	291	312	333	355	376	398	570	682
50	—	356	390	424	457	491	525	559	592	626	901	1075
63	—	524	563	602	641	680	720	759	798	837	1173	1375

Additional Weight (g)

Bore size (mm)		12	16	20	25	32	40	50	63
Both ends tapped		—	—	—	—	—	6	6	19
Rod end male thread	Male thread	1.5	3	6	12	26	27	53	53
	Nut	1	2	4	8	17	17	32	32
With boss on head end		0.7	1.3	2	3	5	7	13	25
Built-in one-touch fittings		—	—	—	—	12	12	21	21
Foot (Incl. mounting bolts)		—	—	—	—	—	153	242	316
Rod flange (Incl. mounting bolts)		—	—	—	—	—	213	372	558
Head flange (Incl. mounting bolts)		—	—	—	—	—	198	348	534
Double clevis (Incl. pin, retaining rings, bolts)		—	—	—	—	—	196	393	554

With Auto Switch (g)

Bore size (mm)	Cylinder stroke (mm)											
	5	10	15	20	25	30	35	40	45	50	75	100
12	71	77	83	89	96	102	—	—	—	—	—	—
16	74	82	89	97	105	113	—	—	—	—	—	—
20	119	132	144	156	168	180	192	204	217	229	—	—
25	162	177	192	208	223	238	254	269	284	300	—	—
32	227	247	266	286	306	326	345	365	385	404	504	604
40	240	261	283	305	326	348	369	391	413	434	546	658
50	—	433	466	499	532	565	598	630	663	697	869	1041
63	—	622	660	698	736	774	812	850	888	926	1124	1321

Additional Weight (g)

Bore size (mm)		12	16	20	25	32	40	50	63
Both ends tapped		—	—	—	—	—	6	6	19
Rod end male thread	Male thread	1.5	3	6	12	26	27	53	53
	Nut	1	2	4	8	17	17	32	32
With boss on head end		0.7	1.3	2	3	5	7	13	25
Built-in one-touch fittings		—	—	—	—	12	12	21	21
Foot (Incl. mounting bolts)		—	—	—	—	—	153	242	316
Rod flange (Incl. mounting bolts)		—	—	—	—	—	213	372	558
Head flange (Incl. mounting bolts)		—	—	—	—	—	198	348	534
Double clevis (Incl. pin, retaining rings and bolts)		—	—	—	—	—	196	393	554

1g = 0.0353 oz
1kg = 2.2046 lb

Standard

Single Acting

Double Rod

Axial Piping

Water Resistant

High Lateral Load

End Lock

Clean Series

Copper/Fluorine free series

Construction and Parts

Warranty and Operating Instructions

Mounting and Auto Switches

Made to Order

Weight - Long Stroke

(g)

Without Auto Switch

Bore size (mm)	Cylinder stroke (mm)					
	125	150	175	200	250	300
32	708	817	918	1017	1215	1415
40	888	997	1107	1217	1438	1657
50	1352	1517	1682	1841	2177	2507
63	1706	1900	2095	2292	2676	3065
80	2832	3130	3429	3725	4324	4921
100	4540	4906	5270	5634	6367	7096

Additional Weight

Bore size (mm)		32	40	50	63	80	100
Rod end male thread	Male thread	26	27	53	53	120	175
	Nut	17	17	32	32	49	116
Foot (Including mounting bolts)		146	158	253	349	672	1113
Rod flange (Including mounting bolts)		165	198	348	534	1017	1309
Head flange (Including mounting bolts)		165	198	348	534	1017	1309
Double clevis (Including pin, retaining rings, bolts)		151	196	393	554	1109	1887

With Auto Switch

Bore size (mm)	Cylinder stroke (mm)					
	125	150	175	200	250	300
32	726	826	927	1026	1224	1424
40	902	1012	1121	1231	1451	1671
50	1367	1532	1697	1856	2192	2522
63	1730	1924	2119	2316	2700	3089
80	2856	3154	3453	3749	4348	4945
100	4578	4944	5308	5672	6405	7134

Calculation: (Example) **CQ2D32-200DCMZ**

- Basic weight: CQ2A32-200DCZ 1017 g
- Additional weight: Rod end male thread 43 g
- Double clevis 151 g
- 1211 g

Add weight of each auto switch when auto switches are mounted.

Weight - Large Bore

Without Auto Switch

(kg)

Bore size (mm)	Cylinder stroke (mm)												
	10	20	30	40	50	75	100	125	150	175	200	250	300
125	5.24	5.48	5.71	5.94	6.18	6.76	7.35	7.93	8.52	9.10	9.69	10.86	12.03
140	6.19	6.44	6.71	6.98	7.25	7.90	8.57	9.23	9.90	10.56	11.23	12.55	13.88
160	8.57	8.88	9.20	9.52	9.84	10.64	11.44	12.25	13.05	13.85	14.65	16.26	17.85
180	11.54	11.92	12.31	12.70	13.09	14.05	15.03	16.00	16.97	17.93	18.90	20.84	22.78
200	14.56	15.07	15.49	15.92	16.34	17.41	18.47	19.54	20.60	21.67	22.82	24.85	26.99

Additional Weight

(kg)

Bore size (mm)		125	140	160 180 200
Rod end male thread	Male thread	0.31	0.31	0.48
	Nut	0.16	0.16	0.26

Calculation: (Example) **CDQ2B125-30DCMZ**

- Basic weight: CDQ2B125-30DCZ..... 5.77 kg
- Additional weight: Rod end male thread... 0.47 kg
- 6.24 kg

With Auto Switch

(kg)

Bore size (mm)	Cylinder stroke (mm)												
	10	20	30	40	50	75	100	125	150	175	200	250	300
125	5.30	5.54	5.77	6.01	6.24	6.83	7.40	7.99	8.58	9.16	9.75	10.92	12.09
140	6.26	6.51	6.78	7.05	7.32	7.97	8.64	9.30	9.97	10.63	11.30	12.62	13.95
160	8.65	8.96	9.28	9.60	9.92	10.72	11.52	12.33	13.13	13.93	14.73	16.34	17.93
180	11.62	12.00	12.39	12.78	13.17	14.13	15.11	16.08	17.05	18.01	18.98	20.92	22.86
200	14.64	15.15	15.57	16.00	16.42	17.49	18.55	19.62	20.68	21.75	22.90	24.93	27.07

1g = 0.0353 oz

1kg = 2.2046 lb

Standard Options
(For details, refer to Best Pneumatics, page 7-10-1.)

Symbol	Specifications	CQ2	NCQ2
-XB6	Heat resistant cylinder (150°C) w/o auto switch only	●	●
-XB7	Cold resistant cylinder w/o auto switch only	●	●
-XB9	Low speed cylinder (10 to 50 mm/s)	●	●
-XB10	Intermediate stroke (Using exclusive body)	●	
-XB11	Long stroke type, Air-hydro type only	●	
-XB13	Low speed cylinder (5 to 50 mm/s)	●	●
-XB14	Cylinder with heat resistant auto switch ø16 to 63 only	●	●
-XB18	Low friction cylinder, ø32 to 100 only	●	
-XC4	With heavy duty scraper, ø20 to 100 only	●	●
-XC6	Piston rod and rod end nut made of stainless steel	●	●
-XC8	Adjustable stroke cylinder/Adjustable extension type	●	●
-XC9	Adjustable stroke cylinder/Adjustable retraction type	●	●
-XC10	Dual stroke cylinder/Double rod type	●	●
-XC11	Dual stroke cylinder/Single rod type	●	●
-XC18	NPT finish piping port	●	
-XC35	With coil scraper, ø32 to 100 only	●	●
-XC36	With boss in rod side	●	
-XC58	Water resistance improved type/Built-in hard plastic magnet, ø20 to 100 only	●	
-XC59	Fluoro rubber for seal/Built-in hard plastic magnet, ø20 to 100 only	●	
-X202	Same overall length dimension as Series CQ1, Except ø16, 25	●	
-X203	Same L dimension from rod cover as Series CQ1, ø20, 32 only	●	
-X293	Same overall length as Series CQ1W, Except ø16, 25	●	
-X144	Change of port location, ø12 to 25 only	●	
-X271	Fluoro rubber for seals	●	
-X525	Long stroke of adjustable extension stroke cylinder (-XC8)	●	
-X526	Long stroke of adjustable retraction stroke cylinder (-XC9)	●	
-X636	Intermediate stroke of double rod type	●	

●: Available

Standard

Single Acting

Double Rod

Axial Piping

Water Resistant

High Lateral Load

End Lock

Clean Series

Copper/Fluorine free series

Construction and Parts

Warranty and Operating Instructions

Mounting and Auto Switches

Made to Order

Ø12 to Ø25 - Without Auto Switch

Standard (Through-hole): (N)CQ2B

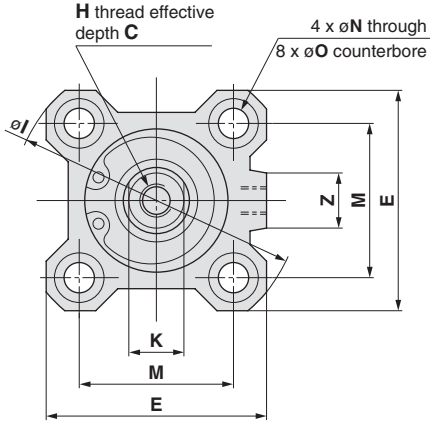

Both ends tapped: (N)CQ2A

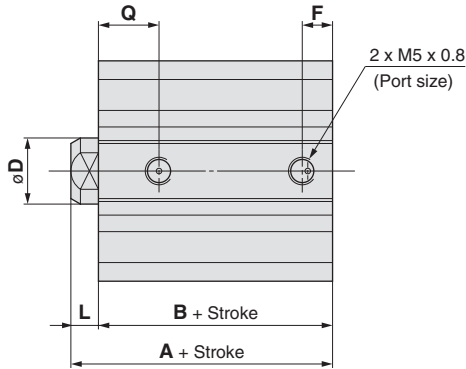
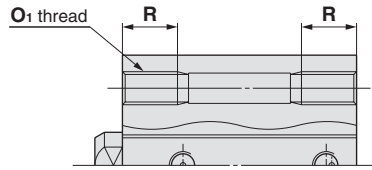

Both Ends Tapped Style

Bore size (mm)	CQ2 O ₁	NCQ2 O ₁ inch	R
12	M4 x 0.7	#8-32UNC	7
16	M4 x 0.7	#8-32UNC	7
20	M6 x 1.0	1/4-20UNC	10
25	M6 x 1.0	1/4-20UNC	10

With boss on head end

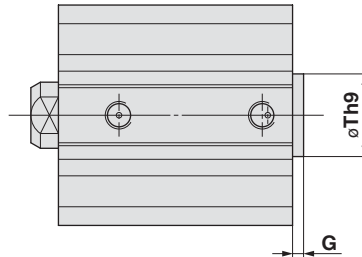

Rod end male thread

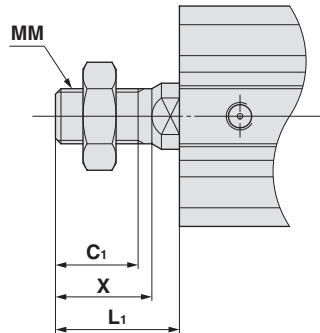

CQ2 Rod End Male Thread

Bore size (mm)	C ₁	X	MM	L ₁
12	9	10.5	M5 x 0.8	14
16	10	12	M6 x 1.0	15.5
20	12	14	M8 x 1.25	18.5
25	15	17.5	M10 x 1.25	22.5

NCQ2 Rod End Male Thread

Bore size (mm)	X	MM inch	L ₁
12	8	#8-32UNC	11.5
16	8	#8-32UNC	11.5
20	8	#10-32UNF	12.5
25	9.5	1/4-28UNF	14.5

C₁ dim. not applicable

Basic Style

Bore size (mm)	Stroke range (mm)	A	B	CQ2 C	NCQ2 C	D	E	F	CQ2 H	NCQ2 H inch	I	K	L	M	N	O	Q	Z
12	5 to 30	20.5	17	6	5.4	6	25	5	M3 x 0.5	#8-32UNC	32	5	3.5	15.5	3.5	6.5 depth 3.5	7.5	—
16	5 to 30	22	18.5	8	5.4	8	29	5.5	M4 x 0.7	#8-32UNC	38	6	3.5	20	3.5	6.5 depth 3.5	8	10
20	5 to 50	24	19.5	7	7	10	36	5.5	M5 x 0.8	#10-32UNF	47	8	4.5	25.5	5.5	9 depth 7	9	10
25	5 to 50	27.5	22.5	12	10	12	40	5.5	M6 x 1.0	1/4-28UNF	52	10	5	28	5.5	9 depth 7	11	10

Note) External dimensions with rubber bumper are same as standard type as shown above.

* For details about the rod end nut and accessory brackets, refer to page 178.

Foot: (N)CQ2L

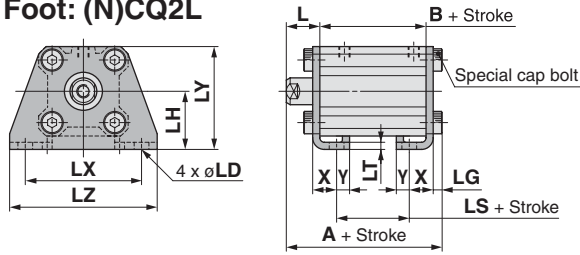

Rod end male thread

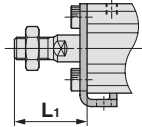

Rod flange: (N)CQ2F

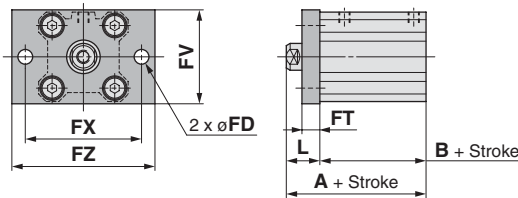

Rod end male thread

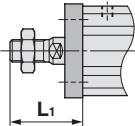

Head flange: (N)CQ2G

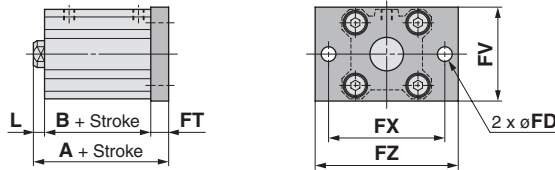

Rod end male thread

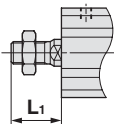

Double clevis: (N)CQ2D

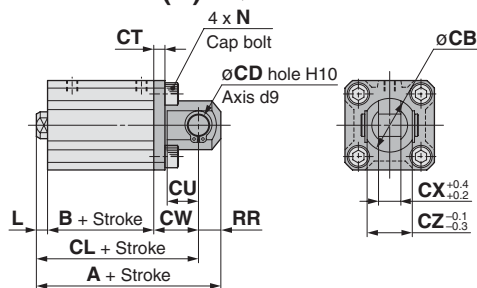

Rod end male thread

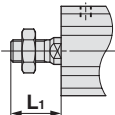

Foot Style

Bore size (mm)	Stroke range (mm)	A	B	L	CQ2 L1	NCQ2 L1	LD	LG	LH	LS	LT	LX	LY	LZ	X	Y
12	5 to 30	35.3	17	13.5	24	21.5	4.5	2.8	17	5	2	34	29.5	44	8	4.5
16	5 to 30	36.8	18.5	13.5	25.5	21.5	4.5	2.8	19	6.5	2	38	33.5	48	8	5
20	5 to 50	41.2	19.5	14.5	28.5	22.5	6.6	4	24	7.5	3.2	48	42	62	9.2	5.8
25	5 to 50	44.7	22.5	15	32.5	24.5	6.6	4	26	7.5	3.2	52	46	66	10.7	5.8

Foot bracket material: Carbon steel

Rod Side Flange Style

Bore size (mm)	Stroke range (mm)	A	B	FD	FT	FV	FX	FZ	L	CQ2 L1	NCQ2 L1
12	5 to 30	30.5	17	4.5	5.5	25	45	55	13.5	24	21.5
16	5 to 30	32	18.5	4.5	5.5	30	45	55	13.5	25.5	21.5
20	5 to 50	34	19.5	6.6	8	39	48	60	14.5	28.5	22.5
25	5 to 50	37.5	22.5	6.6	8	42	52	64	15	32.5	24.5

Flange bracket material: Carbon steel

Head Side Flange Style

Bore size (mm)	Stroke range (mm)	A	L	CQ2 L1	NCQ2 L1
12	5 to 30	26	3.5	14	11.5
16	5 to 30	27.5	3.5	15.5	11.5
20	5 to 50	32	4.5	18.5	12.5
25	5 to 50	35.5	5	22.5	14.5

Flange bracket material: Carbon steel

(* Dimensions except A, L and L1 are the same as rod side flange style.)

Double Clevis Style

Bore size (mm)	Stroke range (mm)	A	B	CB	CQ2 CD	NCQ2 CD inch	CL	CT	CU	CW	CX	CZ	L
12	5 to 30	40.5	17	12	5	3/16	34.5	4	7	14	5	10	3.5
16	5 to 30	43	18.5	14	5	3/16	37	4	10	15	6.5	12	3.5
20	5 to 50	51	19.5	20	8	5/16	42	5	12	18	8	16	4.5
25	5 to 50	57.5	22.5	24	10	3/8	47.5	5	14	20	10	20	5

Bore size (mm)	CQ2 L1	NCQ2 L1	CQ2 N	NCQ2 N inch	RR
12	14	11.5	M4 x 0.7	#8-32UNC	6
16	15.5	11.5	M4 x 0.7	#8-32UNC	6
20	18.5	12.5	M6 x 1.0	1/4-20UNC	9
25	22.5	14.5	M6 x 1.0	1/4-20UNC	10

Standard

Single Acting

Double Rod

Axial Piping

Water Resistant

High Lateral Load

End Lock

Clean Series

Copper/Fluorine free series

Construction and Parts

Warranty and Operating Instructions

Mounting and Auto Switches

Made to Order

ø12 to ø25 - With Auto Switch

Standard (Through-hole): (N)CDQ2B

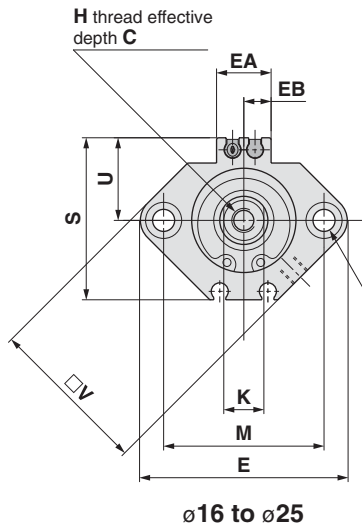

Both ends tapped: (N)CDQ2A

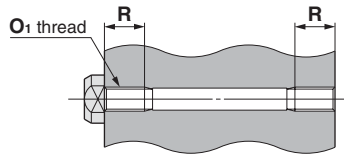

With boss on head end

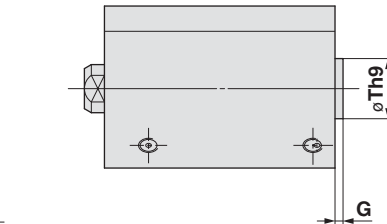

Rod end male thread

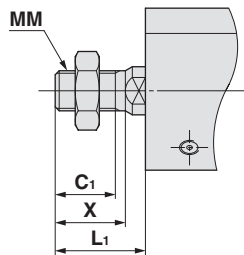

Both Ends Tapped Style

Bore size (mm)	CQ2 O ₁	NCQ2 O ₁ inch	R
12	M4 x 0.7	#8-32UNC	7
16	M4 x 0.7	#8-32UNC	7
20	M6 x 1.0	1/4-20UNC	10
25	M6 x 1.0	1/4-20UNC	10

With Boss in Head Side (CQ2 only)

Bore size (mm)	G	Th9
12	1.5	15 ⁰ _{-0.043}
16	1.5	20 ⁰ _{-0.052}
20	2	13 ⁰ _{-0.043}
25	2	15 ⁰ _{-0.043}

Note 1) With boss in rod side: Option (Suffix "-XC36" to the end of part number.)

CQ2 Rod End Male Thread

Bore size (mm)	C ₁	X	MM	L1
12	9	10.5	M5 x 0.8	14
16	10	12	M6 x 1.0	15.5
20	12	14	M8 x 1.25	18.5
25	15	17.5	M10 x 1.25	22.5

NCQ2 Rod End Male Thread

Bore size (mm)	X	MM inch	L1
12	8	#8-32UNC	11.5
16	8	#8-32UNC	11.5
20	8	#10-32UNF	12.5
25	9.5	1/4-28UNF	14.5

C₁ dim. not applicable

Basic Style

Bore size (mm)	Stroke range (mm)	A	B	CQ2 C	NCQ2 C	D	E	F	CQ2 H	NCQ2 H inch	K	L	M	N	O	Q	S	U	V
12	5 to 30	31.5	28	6	5.4	6	32	6.5	M3 x 0.5	#8-32UNC	5	3.5	22	3.5	6.5 depth 3.5	11	35.5	19.5	25
16	5 to 30	34	30.5	8	5.4	8	38	5.5	M4 x 0.7	#8-32UNC	6	3.5	28	3.5	6.5 depth 3.5	10	41.5	22.5	29
20	5 to 50	36	31.5	7	7	10	47	5.5	M5 x 0.8	#10-32UNF	8	4.5	36	5.5	9 depth 7	10.5	48	24.5	36
25	5 to 50	37.5	32.5	12	10	12	52	5.5	M6 x 1.0	1/4-28UNF	10	5	40	5.5	9 depth 7	11	53.5	27.5	40

Note 2) External dimensions with rubber bumper are same as standard type as shown above.

* For details about the rod end nut and accessory brackets, refer to page 178.

Note 3) For length dimensions of intermediate stroke cylinders, refer to page 4.

Foot: (N)CDQ2L

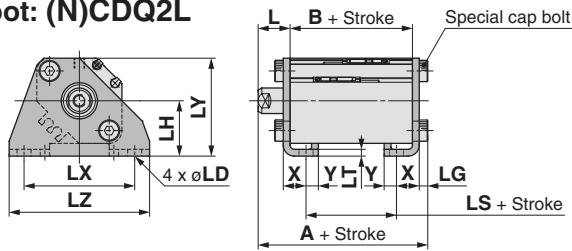

Rod end male thread

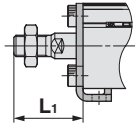

Rod flange: (N)CDQ2F

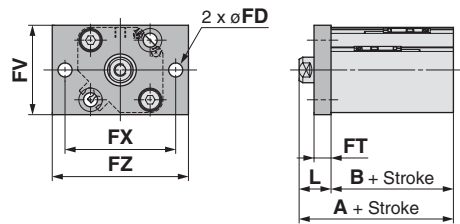

Rod end male thread

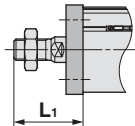

Head flange: (N)CDQ2G

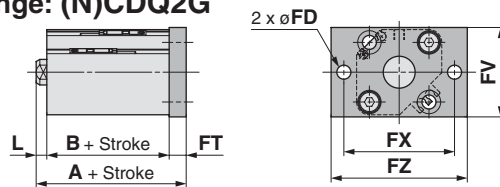

Rod end male thread

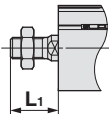

Double clevis: (N)CDQ2D

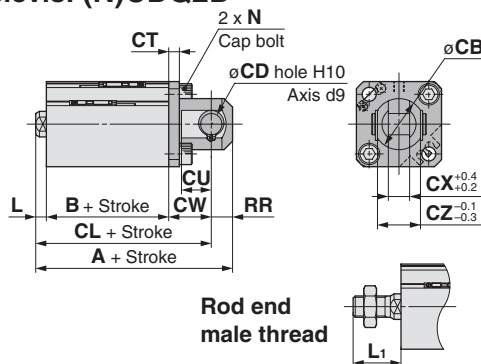

Rod end male thread

Foot Style

Bore size (mm)	Stroke range (mm)	A	B	L	CQ2 L1	NCQ2 L1	LD	LG	LH	LS	LT	LX	LY	LZ	X	Y
12	5 to 30	46.3	28	13.5	24	21.5	4.5	2.8	17	16	2	34	29.5	44	8	4.5
16	5 to 30	48.8	30.5	13.5	25.5	21.5	4.5	2.8	19	18.5	2	38	33.5	48	8	5
20	5 to 50	53.2	31.5	14.5	28.5	22.5	6.6	4	24	19.5	3.2	48	42	62	9.2	5.8
25	5 to 50	54.7	32.5	15	32.5	24.5	6.6	4	26	17.5	3.2	52	46	66	10.7	5.8

Foot bracket material: Carbon steel

Rod Side Flange Style

Bore size (mm)	Stroke range (mm)	A	B	FD	FT	FV	FX	FZ	L	CQ2 L1	NCQ2 L1
12	5 to 30	41.5	28	4.5	5.5	25	45	55	13.5	24	21.5
16	5 to 30	44	30.5	4.5	5.5	30	45	55	13.5	25.5	21.5
20	5 to 50	46	31.5	6.6	8	39	48	60	14.5	28.5	22.5
25	5 to 50	47.5	32.5	6.6	8	42	52	64	15	32.5	24.5

Flange bracket material: Carbon steel

Head Side Flange Style

Bore size (mm)	Stroke range (mm)	A	L	CQ2 L1	NCQ2 L1
12	5 to 30	37	3.5	14	11.5
16	5 to 30	39.5	3.5	15.5	11.5
20	5 to 50	44	4.5	18.5	12.5
25	5 to 50	45.5	5	22.5	14.5

(* Dimensions except A, L and L1 are the same as rod side flange style.)

Flange bracket material: Carbon steel

Double Clevis Style

Bore size (mm)	Stroke range (mm)	A	B	CB	CD	NCQ2 CD inch	CL	CT	CU	CW	CX	CZ	L	CQ2 L1	NCQ2 L1
12	5 to 30	51.5	28	12	5	3/16	45.5	4	7	14	5	10	3.5	14	11.5
16	5 to 30	55	30.5	14	5	3/16	49	4	10	15	6.5	12	3.5	15.5	11.5
20	5 to 50	63	31.5	20	8	5/16	54	5	12	18	8	16	4.5	18.5	12.5
25	5 to 50	67.5	32.5	24	10	3/8	57.5	5	14	20	10	20	5	22.5	14.5

Bore size (mm)	CQ2 N	NCQ2 N inch	RR
12	M4 x 0.7	#8-32UNC	6
16	M4 x 0.7	#8-32UNC	6
20	M6 x 1.0	1/4-20UNC	9
25	M6 x 1.0	1/4-20UNC	10

Double clevis bracket material: Carbon steel

* For details about the rod end nut and accessory brackets, refer to page 178.

** Clevis pin and snap ring are shipped together.

Standard

Single Acting

Double Rod

Axial Piping

Water Resistant

High Lateral Load

End Lock

Clean Series

Copper/Fluorine free series

Construction and Parts

Warranty and Operating Instructions

Mounting and Auto Switches

Made to Order

Series (N)CQ2

Double Acting, Single Rod

Dimensions - Standard

ø32 to ø50 - With Auto Switch

(without auto switches, only the A, B, F, P and Q dimensions will be changed. Refer to the dimension table.)

Standard (Through-hole): (N)CQ2B/(N)CDQ2B

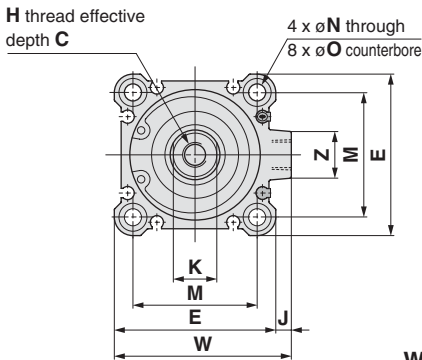

Both ends tapped: (N)CQ2A/(N)CDQ2A

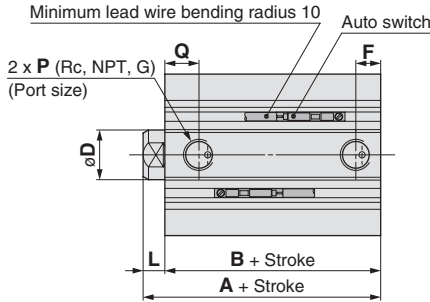
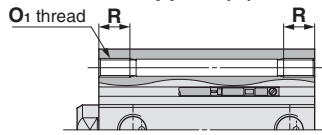

With boss on head end

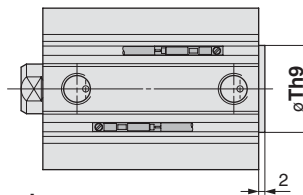

Rod end male thread

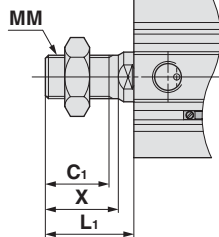

Built-in one-touch fittings: ø32 to ø50

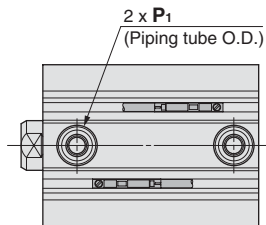
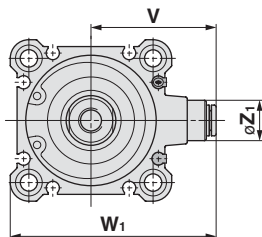

Both Ends Tapped Style

Bore size (mm)	CQ2 O ₁	NCQ2 O ₁ inch	R
32	M6 x 1.0	1/4-20UNC	10
40	M6 x 1.0	1/4-20UNC	10
50	M8 x 1.25	5/16-18UNC	14

With Boss in Head Side (CQ2 only)

Bore size (mm)	Th9
32	21 ⁰ _{-0.052}
40	28 ⁰ _{-0.052}
50	35 ⁰ _{-0.062}

CQ2 Rod End Male Thread

Bore size (mm)	C ₁	X	MM	L1
32	20.5	23.5	M14 x 1.5	28.5
40	20.5	23.5	M14 x 1.5	28.5
50	26	28.5	M18 x 1.5	33.5

NCQ2 Rod End Male Thread

Bore size (mm)	X	MM inch	L1
32	12.7	5/16-24UNF	19.7
40	16	3/8-24UNF	23
50	19.5	1/2-20UNF	27.5

C₁ dim. not applicable

Built-in One-touch Fittings (CQ2 only)

Bore size (mm)	Z ₁	P ₁	V	W ₁
32	13	6	36.5	59
40	13	6	40.5	66
50	16	8	50	82

Basic Style

Auto switch shown above is D-A73 type and D-A80 type. For the auto switch mounting position and its mounting height, refer to pages 188 to 194.

Bore size (mm)	Stroke range (mm)	Without auto switch					With auto switch					CQ2 C	NCQ2 C	D	E	CQ2 H	NCQ2 H inch		
		A	B	F	P (CQ2)	P (NCQ2)	Q	A	B	F	P (CQ2)							P (NCQ2)	Q
32	5			5.5	M5 x 0.8	M5 X 0.8	11.5	40	33	7.5	Rc 1/8	NPT 1/8	10.5	13	13.3	16	45	M8 x 1.25	5/16-24UNF
	10 to 50	30	23	7.5	Rc 1/8	NPT 1/8	10.5												
	75, 100	40	33																
40	5 to 50	36.5	29.5	8	Rc 1/8	NPT 1/8	11	46.5	39.5	8	Rc 1/8	NPT 1/8	11	13	18.3	16	52	M8 x 1.25	3/8-24UNF
	75, 100	46.5	39.5																
50	10 to 50	38.5	30.5	10.5	Rc 1/4	NPT 1/4	10.5	48.5	40.5	10.5	Rc 1/4	NPT 1/4	10.5	15	17.6	20	64	M10 x 1.5	1/2-20UNF
	75, 100	48.5	40.5																

Bore size (mm)	I	J	K	L	M	N	O	S	U	Z
32	60	4.5	14	7	34	5.5	9 depth 7	58.5	31.5	14
40	69	5	14	7	40	5.5	9 depth 7	66	35	14
50	86	7	17	8	50	6.6	11 depth 8	80	41	19

Note 1) External dimensions with rubber bumper are same as standard type as shown above.

* For details about the rod end nut and accessory brackets, refer to page 178.

Note 2) For length dimensions of intermediate stroke cylinder, refer to page 4, because we have the spacer-installed type and the exclusive body type (-XB10).

Foot: (N)CQ2L/(N)CDQ2L

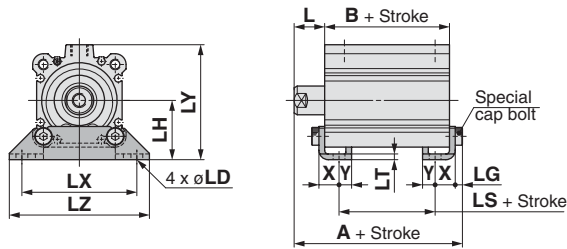

Rod end male thread

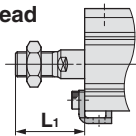

Foot Style

Bore size (mm)	Stroke range (mm)	Without auto switch			With auto switch			L	CQ2 L1	NCQ2 L1	LD	LG	LH	LT
		A	B	LS	A	B	LS							
32	5 to 50	47.2	23	7	57.2	33	17	17	38.5	29.7	6.6	4	30	3.2
	75, 100	57.2	33	17										
40	5 to 50	53.7	29.5	13.5	63.7	39.5	23.5	17	38.5	33	6.6	4	33	3.2
	75, 100	63.7	39.5	23.5										
50	10 to 50	56.7	30.5	7.5	66.7	40.5	17.5	18	43.5	37.5	9	5	39	3.2
	75, 100	66.7	40.5	17.5										

Foot bracket material: Carbon steel

Bore size (mm)	LX	LY	LZ	X	Y
32	57	57	71	11.2	5.8
40	64	64	78	11.2	7
50	79	78	95	14.7	8

Rod flange: (N)CQ2F/(N)CDQ2F

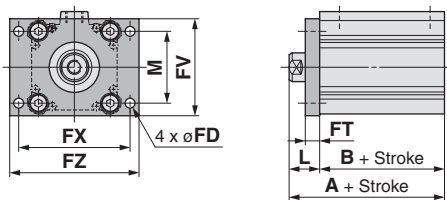

Rod end male thread

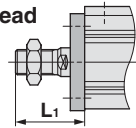

Rod Side Flange Style

Bore size (mm)	Stroke range (mm)	Without auto switch		With auto switch		FD	FT	FV	FX	FZ	L	CQ2 L1	NCQ2 L1	M
		A	B	A	B									
32	5 to 50	40	23	50	33	5.5	8	48	56	65	17	38.5	29.7	34
	75, 100	50	33											
40	5 to 50	46.5	29.5	56.5	39.5	5.5	8	54	62	72	17	38.5	33	40
	75, 100	56.5	39.5											
50	10 to 50	48.5	30.5	58.5	40.5	6.6	9	67	76	89	18	43.5	37.5	50
	75, 100	58.5	40.5											

Flange bracket material: Carbon steel

Head flange: (N)CQ2G/(N)CDQ2G

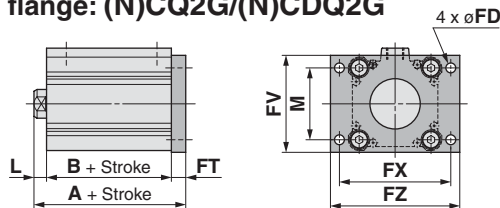

Rod end male thread

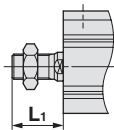

Head Side Flange Style

Bore size (mm)	Stroke range (mm)	Without auto switch		With auto switch		CQ2 L1	NCQ2 L1
		A	B	A	B		
32	5 to 50	38	48	48	7	28.5	19.7
	75, 100	48	48				
40	5 to 50	44.5	54.5	54.5	7	28.5	23
	75, 100	54.5	54.5				
50	10 to 50	47.5	57.5	57.5	8	33.5	27.5
	75, 100	57.5	57.5				

(*Dimensions except A, L, and L1 are the same as rod side flange style)

Flange bracket material: Carbon steel

Double clevis: (N)CQ2D/(N)CDQ2D

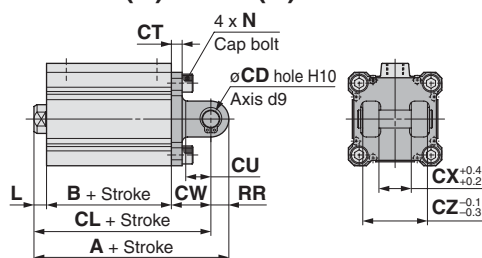

Rod end male thread

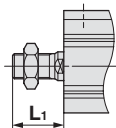

Double Clevis Style

Bore size (mm)	Stroke range (mm)	Without auto switch			With auto switch			CQ2 CD	NCQ2 CD inch	CT	CU	CW	CX	CZ	L
		A	B	CL	A	B	CL								
32	5 to 50	60	23	50	70	33	60	10	3/8	5	14	20	18	36	7
	75, 100	70	33	60											
40	5 to 50	68.5	29.5	58.5	78.5	39.5	68.5	10	3/8	6	14	22	18	36	7
	75, 100	78.5	39.5	68.5											
50	10 to 50	80.5	30.5	66.5	90.5	40.5	76.5	14	1/2	7	20	28	22	44	8
	75, 100	90.5	40.5	76.5											

Bore size (mm)	CQ2 L1	NCQ2 L1	CQ2 N	NCQ2 N inch	RR
32	28.5	19.7	M6 x 1.0	1/4-20UNC	10
40	28.5	23	M6 x 1.0	1/4-20UNC	10
50	33.5	27.5	M8 x 1.25	5/16-18UNC	14

Double clevis bracket material: Cast iron

* For details about the rod end nut and accessory brackets, refer to page 178.

** Clevis pin and snap ring are shipped together.

- Standard
- Single Acting
- Double Rod
- Axial Piping
- Water Resistant
- High Lateral Load
- End Lock
- Clean Series
- Copper/Fluorine free series
- Construction and Parts
- Warranty and Operating Instructions
- Mounting and Auto Switches
- Made to Order

Series (N)CQ2

Double Acting, Single Rod

Dimensions - Standard

ø63 to ø100 - With Auto Switch

(Without auto switches, only the A, B dimensions will be changed. Refer to the dimension table.)

Both ends tapped: (N)CQ2A/(N)CDQ2A

Standard (Through-hole):
(N)CQ2B/(N)CDQ2B

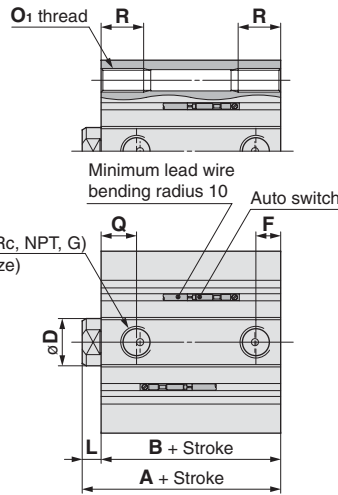
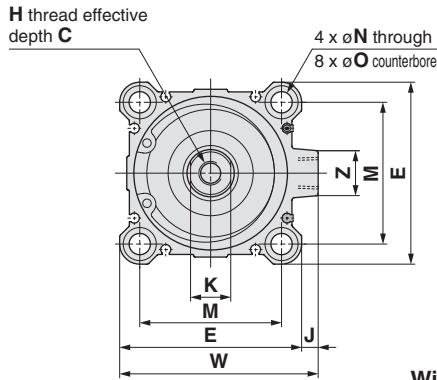

With boss on head end

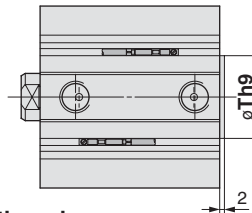

Rod end male thread

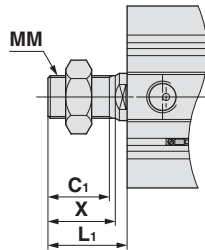

Built-in one-touch fittings: ø63

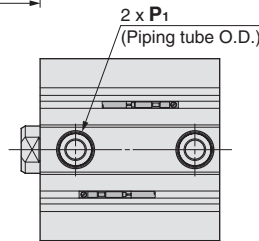
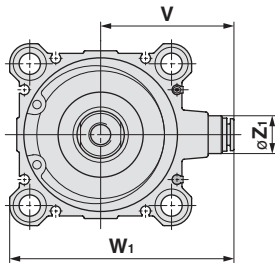

Both Ends Tapped Style

Bore size (mm)	CQ2 O ₁	NCQ2 O ₁ inch	R
63	M10 x 1.5	7/16-14UNC	18
80	M12 x 1.75	1/2-13UNC	22
100	M12 x 1.75	1/2-13UNC	22

With Boss in Head Side (CQ2 only)

Bore size (mm)	Th9
63	35 ⁰ _{-0.062}
80	43 ⁰ _{-0.062}
100	59 ⁰ _{-0.074}

Note1) With boss in rod side: Option (Suffix "-XC36" to the end of part number.)

CQ2 Rod End Male Thread

Bore size (mm)	C ₁	X	MM	L ₁
63	26	28.5	M18 x 1.5	33.5
80	32.5	35.5	M22 x 1.5	43.5
100	32.5	35.5	M26 x 1.5	43.5

NCQ2 Rod End Male Thread

Bore size (mm)	X	MM inch	L ₁
63	19.5	1/2-20UNF	27.5
80	25.5	5/8-18UNF	35.5
100	28.5	3/4-16UNF	40.5

C₁ dim. not applicable

Built-in One-touch Fittings (CQ2 only)

Bore size (mm)	Z ₁	P ₁	V	W ₁
63	16	8	56.5	95

Basic Style

For the auto switch mounting position and its mounting height, refer to pages 188-194.

Bore size (mm)	Stroke range (mm)	Without auto switch		With auto switch		CQ2 C	NCQ2 C	D	E	F	CQ2 H	NCQ2 H inch	I	J	K	L	M	N	O
		A	B	A	B														
63	10 to 50	44	36	54	46	15	17.6	20	77	10.5	M10 x 1.5	1/2-20UNF	103	7	17	8	60	9	14 depth 10.5
	75, 100	54	46																
80	10 to 50	53.5	43.5	63.5	53.5	21	24.3	25	98	12.5	M16 x 2.0	5/8-18UNF	132	6	22	10	77	11	17.5 depth 13.5
	75, 100	63.5	53.5																
100	10 to 50	65	53	75	63	27	27	30	117	13	M20 x 2.5	3/4-16UNF	156	6.5	27	12	94	11	17.5 depth 13.5
	75, 100	75	63																

Bore size (mm)	CQ2 P	NCQ2 P inch	Q	S	U	Z
63	Rc 1/4	NPT 1/4	15	93	47.5	19
80	Rc 3/8	NPT 3/8	16	112.5	57.5	26
100	Rc 3/8	NPT 3/8	23	132.5	67.5	26

Note 2) External dimensions with rubber bumper are same as standard type as shown above.

* For details about the rod end nut and accessory brackets, refer to page 178.

Note 3) For length dimensions of intermediate stroke cylinder, refer to page 4.

Foot: (N)CQ2L/(N)CDQ2L

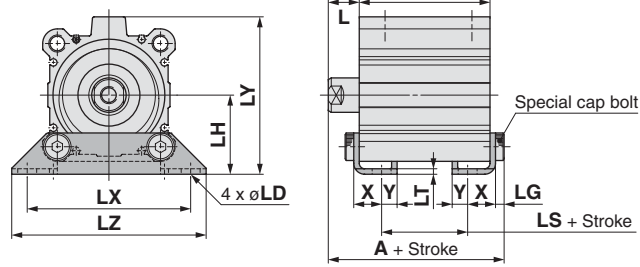

Rod end male thread

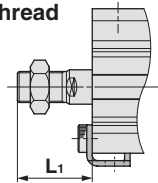

Head flange: (N)CQ2G/(N)CDQ2G

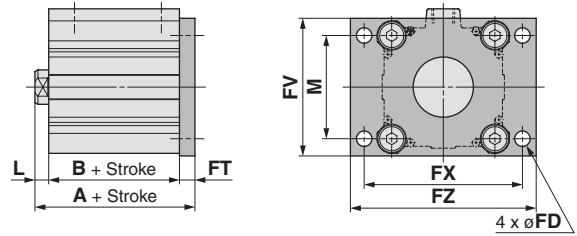

Rod end male thread

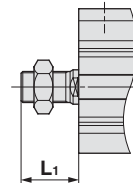

Rod flange: (N)CQ2F/(N)CDQ2F

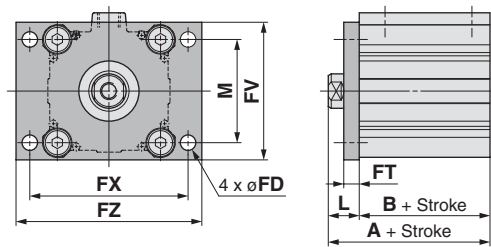

Rod end male thread

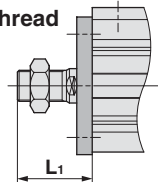

Double clevis: (N)CQ2D/(N)CDQ2D

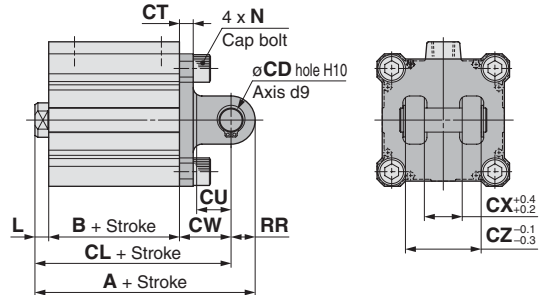

Rod end male thread

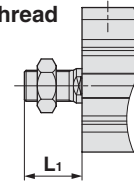

Foot Style

Bore size (mm)	Stroke range (mm)	Without auto switch			With auto switch			L	CQ2 L1	NCQ2 L1	LD	LG	LH
		A	B	LS	A	B	LS						
63	10 to 50	62.2	36	10	72.2	46	20	18	43.5	37.5	11	5	46
	75, 100	72.2	46	20									
80	10 to 50	75	43.5	13.5	85	53.5	23.5	20	53.5	45.5	13	7	59
	75, 100	85	53.5	23.5									
100	10 to 50	88	53	19	98	63	29	22	53.5	50.5	13	7	71
	75, 100	98	63	29									

Bore size (mm)	Stroke range (mm)	LT	LX	LY	LZ	X	Y
63	10 to 50	3.2	95	91.5	113	16.2	9
	75, 100						
80	10 to 50	4.5	118	114	140	19.5	11
	75, 100						
100	10 to 50	6	137	136	162	23	12.5
	75, 100						

Foot bracket material: Carbon steel

Rod Side Flange Style

Bore size (mm)	Stroke range (mm)	Without auto switch		With auto switch		FD	FT	FV	FX	FZ	L	CQ2 L1	NCQ2 L1	M
		A	B	A	B									
63	10 to 50	54	36	64	46	9	9	80	92	108	18	43.5	37.5	60
	75, 100	64	46											
80	10 to 50	63.5	43.5	73.5	53.5	11	11	99	116	134	20	53.5	45.5	77
	75, 100	73.5	53.5											
100	10 to 50	75	53	85	63	11	11	117	136	154	22	53.5	50.5	94
	75, 100	85	63											

Flange bracket material: Carbon steel

Head Side Flange Style

Bore size (mm)	Stroke range (mm)	Without auto switch		With auto switch		L	CQ2 L1	NCQ2 L1
		A	B	A	B			
63	10 to 50	53		63		8	33.5	27.5
	75, 100	63						
80	10 to 50	64.5		74.5		10	43.5	35.5
	75, 100	74.5						
100	10 to 50	76		86		12	43.5	40.5
	75, 100	86						

Flange bracket material: Carbon steel

Double Clevis Style

Bore size (mm)	Stroke range (mm)	Without auto switch		With auto switch		CQ2 CD	NCQ2 CD inch	CL	CT	CU	CW	CX
		A	B	A	B							
63	10 to 50	88	36	98	46	14	1/2	84	8	20	30	22
	75, 100	98	46									
80	10 to 50	109.5	43.5	119.5	53.5	18	3/4	101.5	10	27	38	28
	75, 100	119.5	53.5									
100	10 to 50	132	53	142	63	22	7/8	120	13	31	45	32
	75, 100	142	63									

Double clevis bracket material: Cast iron

Bore size (mm)	Stroke range (mm)	CZ	L	CQ2 L1	NCQ2 L1	CQ2 N	NCQ2 N inch	RR
80	10 to 50	56	10	43.5	35.5	M12 x 1.75	1/2-13UNC	18
	75, 100							
100	10 to 50	64	12	43.5	40.5	M12 x 1.75	1/2-13UNC	22
	75, 100							

* For details about the rod end nut and accessory brackets, refer to page 178.
* Clevis pin and set ring are shipped together.

Standard
Single Acting
Double Rod
Axial Piping
Water Resistant
High Lateral Load
End Lock
Clean Series
Copper/Fluorine free series
Construction and Parts
Warranty and Operating Instructions
Mounting and Auto Switches
Made to Order

Series (N)CQ2

Double Acting, Single Rod
Dimensions - Long Stroke

ø32 to ø50

Both ends tapped: (N)C□Q2A

The dimensions are the same with or without an auto switch.

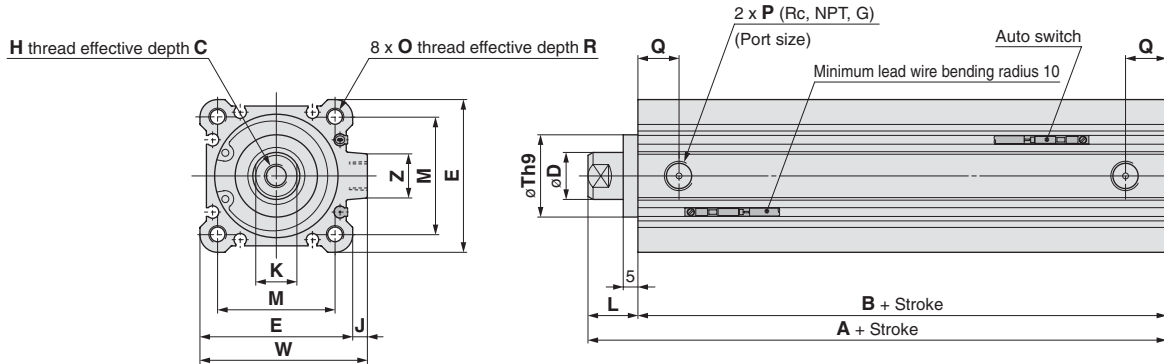

Rod end male thread

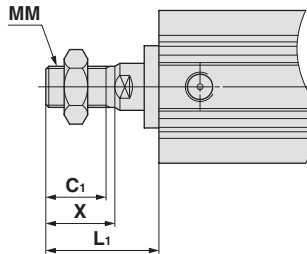

CQ2 Rod End Male Thread

Bore size (mm)	C1	MM	L1	X
32	20.5	M14 x 1.5	38.5	23.5
40	20.5	M14 x 1.5	38.5	23.5
50	26	M18 x 1.5	43.5	28.5

NCQ2 Rod End Male Thread

Bore size (mm)	MM inch	L1	X
32	5/16-24UNF	29.7	12.7
40	3/8-24UNF	33	16
50	1/2-20UNF	37.5	19.5

The dimensions with built-in one-touch fittings are equivalent to those of the CQ2 series, double acting, single rod. Refer to page 14.

"C1" dim. not applicable.

Both Ends Tapped Style

Bore size (mm)	Stroke range (mm)	A	B	CQ2 C	NCQ2 C	D	E	CQ2 H	NCQ2 H inch	I	J	K	L	M	CQ2 O	NCQ2 O inch	CQ2 P	NCQ2 P
32	125 to 200 250, 300	62.5	45.5	13	13.3	16	45	M8 x 1.25	5/16-24UNF	60	4.5	14	17	34	M6 x 1.0	1/4-20UNC	Rc 1/8	NPT 1/8
40		72	55	13	18.3	16	52	M8 x 1.25	3/8-24UNF	69	5	14	17	40	M6 x 1.0	1/4-20UNC	Rc 1/8	NPT 1/8
50		73.5	55.5	15	17.6	20	64	M10 x 1.5	1/2-20UNF	86	7	17	18	50	M8 x 1.25	5/16-18UNC	Rc 1/4	NPT 1/4

Bore size (mm)	Q	R	S	Th9	U	Z
32	12.5	10	58.5	22 ⁰ _{-0.052}	31.5	14
40	14	10	66	28 ⁰ _{-0.052}	35	14
50	14	14	80	35 ⁰ _{-0.062}	41	19

Note 1) For 125 to 200 stroke, strokes are by the 25 mm interval.

Note 2) For length dimensions of intermediate stroke cylinders, refer to page 4.

Foot: (N)C□Q2L

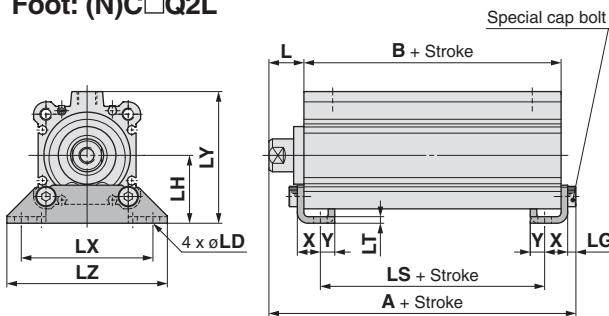

Foot Style

Bore size (mm)	A	B	L	CQ2 L1	NCQ2 L1 inch	LD	LG	LH	LS	LT	LX	LY	LZ	X	Y
32	69.7	45.5	17	38.5	29.7	6.6	4	30	29.5	3.2	57	57	71	11.2	5.8
40	79.2	55	17	38.5	33	6.6	4	33	39	3.2	64	64	78	11.2	7
50	81.7	55.5	18	43.5	37.5	9	5	39	32.5	3.2	79	78	95	14.7	8

Foot bracket material: Carbon steel

* For details about the rod end nut and accessory brackets, refer to page 178.

Rod end male thread

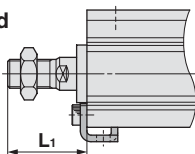

The dimensions are the same with or without an auto switch.

Rod flange: (N)C□Q2F

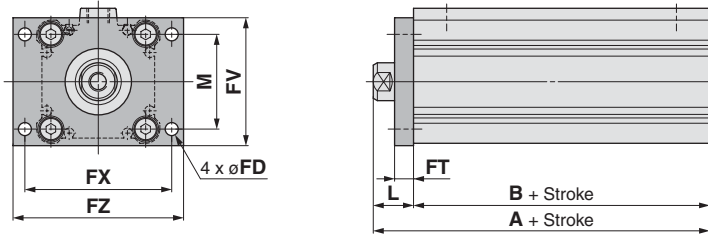

Rod end male thread

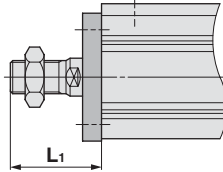

Rod Side Flange Style

Bore size (mm)	A	B	FD	FT	FV	FX	FZ	L
32	62.5	45.5	5.5	8	48	56	65	17
40	72	55	5.5	8	54	62	72	17
50	73.5	55.5	6.6	9	67	76	89	18

Bore size (mm)	CQ2 L1	NCQ2 L1	M
32	38.5	29.7	34
40	38.5	33	40
50	43.5	37.5	50

Flange bracket material: Carbon steel

Head flange: (N)C□Q2G

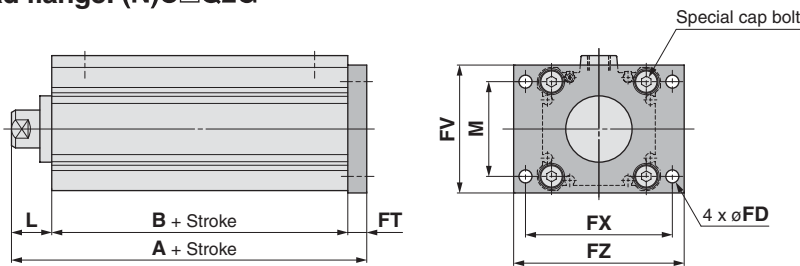

Head Side Flange Style

Bore size (mm)	A	CQ2 L1	NCQ2 L1
32	70.5	38.5	29.7
40	80	38.5	33
50	82.5	43.5	37.5

Flange bracket material: Carbon steel

*Dimensions except A are the same as rod side flange style.

Rod end male thread

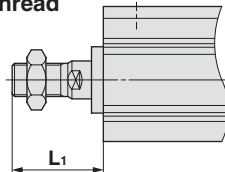

Double clevis: (N)C□Q2D

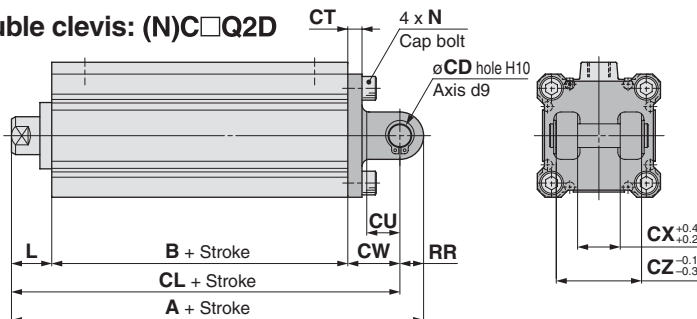

Double Clevis Style

Bore size (mm)	A	B	CQ2 CD	NCQ2 CD inch	CL	CT	CU	CW	CX
32	92.5	45.5	10	3/8	82.5	5	14	20	18
40	104	55	10	3/8	94	6	14	22	18
50	115.5	55.5	14	1/2	101.5	7	20	28	22

Bore size (mm)	CZ	L	CQ2 L1	NCQ2 L1	CQ2 N	NCQ2 N inch	RR
32	36	17	38.5	29.7	M6 x 1.0	1/4-20UNC	10
40	36	17	38.5	33	M6 x 1.0	1/4-20UNC	10
50	44	18	43.5	37.5	M8 x 1.25	5/16-18UNC	14

Double clevis bracket material: Cast iron

* For details about the rod end nut and accessory brackets, refer to page 178.

** Clevis pin and snap ring are shipped together.

Rod end male thread

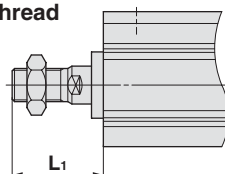

Standard

Single Acting

Double Rod

Axial Piping

Water Resistant

High Lateral Load

End Lock

Clean Series

Copper/Fluorine free series

Construction and Parts

Warranty and Operating Instructions

Mounting and Auto Switches

Made to Order

Series (N)CQ2

Double Acting, Single Rod
Dimensions - Long Stroke

ø63 to ø100

Both ends tapped: (N)C□Q2A

The dimensions are the same with or without an auto switch.

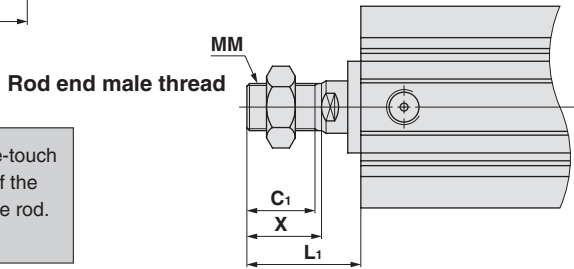
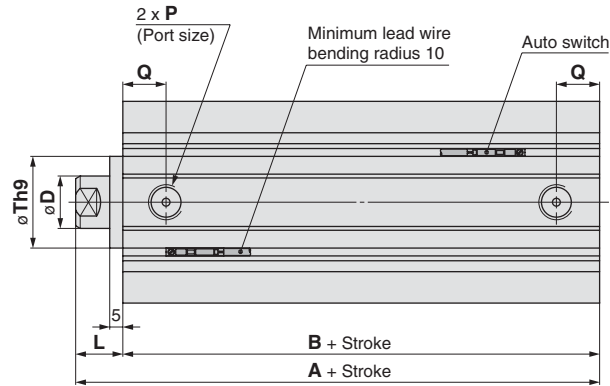
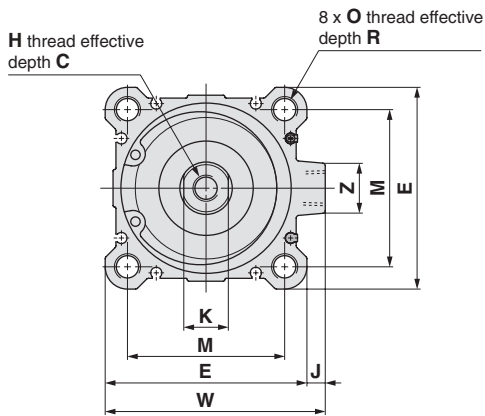

The dimensions with built-in one-touch fittings are equivalent to those of the CQ2 series, double acting, single rod. Refer to page 16.

CQ2 Rod End Male Thread

Bore size (mm)	C1	MM	L1	X
63	26	M18 x 1.5	43.5	28.5
80	32.5	M22 x 1.5	53.5	35.5
100	32.5	M26 x 1.5	53.5	35.5

NCQ2 Rod End Male Thread

Bore size (mm)	X	MM inch	L1
63	19.5	1/2-20UNF	37.5
80	25.5	5/8-18UNF	45.5
100	28.5	3/4-16UNF	50.5

"C1" dim. not applicable

Both Ends Tapped Style

Bore size (mm)	Stroke range (mm)	A	B	CQ2 C	NCQ2 C inch	D	E	CQ2 H	NCQ2 H inch	I	J	K	L	M	CQ2 O	NCQ2 O inch	CQ2 P	NCQ2 P
63	(1) 125 to 200 250, 300	75	57	15	17.6	20	77	M10 x 1.5	1/2-20UNF	103	7	17	18	60	M10 x 1.5	7/16-14UNC	Rc 1/4	NPT 1/4
80		86	66	21	24.3	25	98	M16 x 2.0	5/8-18UNF	132	6	22	20	77	M12 x 1.75	1/2-13UNC	Rc 3/8	NPT 3/8
100		97.5	75.5	27	27	30	117	M20 x 2.5	3/4-16UNF	156	6.5	27	22	94	M12 x 1.75	1/2-13UNC	Rc 3/8	NPT 3/8

Bore size (mm)	Q	R	S	Th9	U	Z
63	16.5	18	93	35 ⁰ _{-0.062}	47.5	19
80	19	22	112.5	43 ⁰ _{-0.062}	57.5	26
100	23	22	132.5	59 ⁰ _{-0.074}	67.5	26

Note 1) For 125 to 200 stroke, strokes are by the 25 mm interval.
Note 2) For length dimensions of intermediate stroke cylinder, refer to page 4.

Foot: (N)C□Q2L

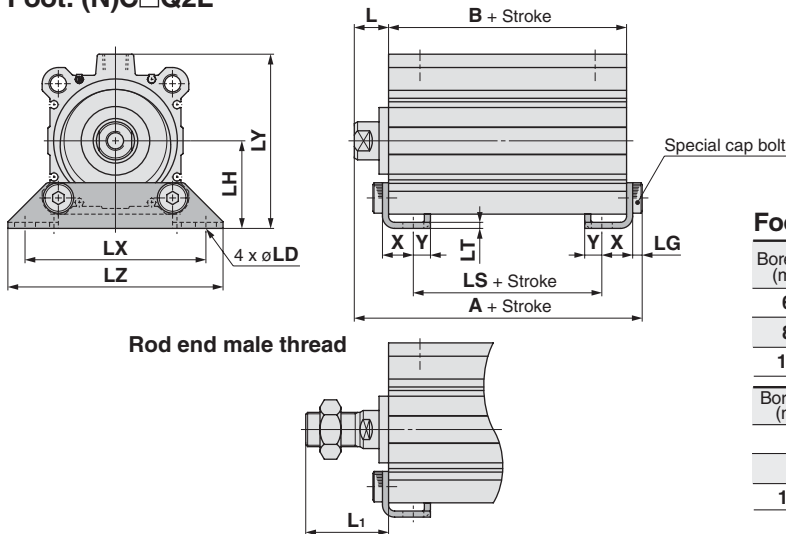

Foot Style

Bore size (mm)	A	B	L	CQ2 L1	NCQ2 L1	LD	LG	LH	LS	LT	LX	LY
63	83.2	57	18	43.5	37.5	11	5	46	31	3.2	95	91.5
80	97.5	66	20	53.5	45.5	13	7	59	36	4.5	118	114
100	110.5	75.5	22	53.5	50.5	13	7	71	41.5	6	137	136

Bore size (mm)	LZ	X	Y
63	113	16.2	9
80	140	19.5	11
100	162	23	12.5

Foot bracket material: Carbon steel

*For details about the rod end nut and accessory brackets, refer to page 178.

The dimensions are the same with or without an auto switch.

Rod flange: (N)C□Q2F

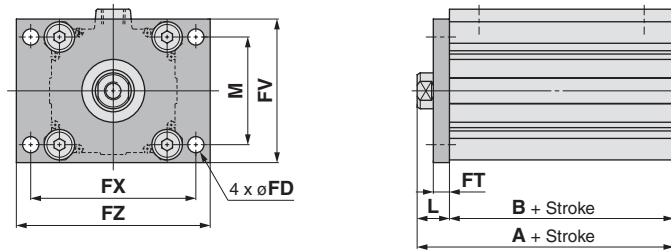

Rod end male thread

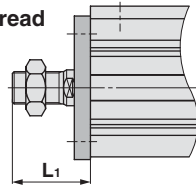

Rod Side Flange Style

Bore size (mm)	A	B	FD	FT	FV	FX	FZ	L
63	75	57	9	9	80	92	108	18
80	86	66	11	11	99	116	134	20
100	97.5	75.5	11	11	117	136	154	22

Bore size (mm)	CQ2 L1	NCQ2 L1	M
63	43.5	37.5	60
80	53.5	45.5	77
100	53.5	50.5	94

Flange bracket material: Carbon steel

Head flange: (N)C□Q2G

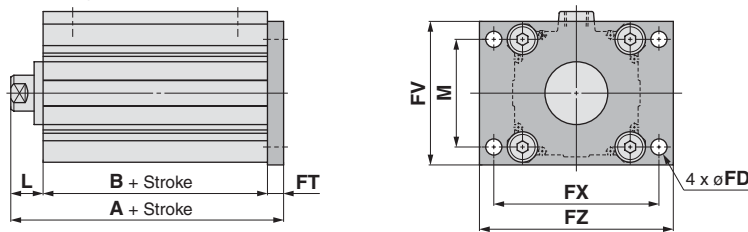

Rod end male thread

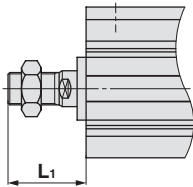

Head Side Flange Style

Bore size (mm)	A	CQ2 L1	NCQ2 L1
63	84	43.5	37.5
80	97	53.5	45.5
100	108.5	53.5	50.5

Flange bracket material: Carbon steel

* Dimensions except A are the same as rod side flange style.

Double clevis: (N)C□Q2D

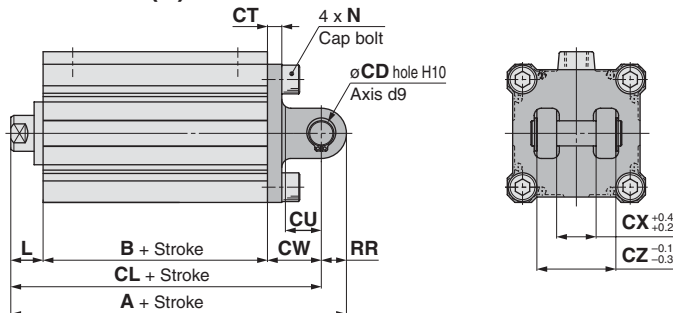

Rod end male thread

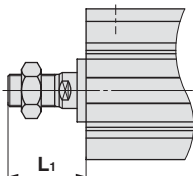

Double Clevis Style

Bore size (mm)	A	B	CQ2 CD	NCQ2 CD inch	CL	CT	CU	CW	CX	CZ
63	119	57	14	1/2	105	8	20	30	22	44
80	142	66	18	3/4	124	10	27	38	28	56
100	164.5	75.5	22	7/8	142.5	13	31	45	32	64

Bore size (mm)	L	CQ2 L1	NCQ2 L1	CQ2 N	NCQ2 N inch	RR
63	18	43.5	37.5	M10 x 1.5	7/16-14UNC	14
80	20	53.5	45.5	M12 x 1.75	1/2-13UNC	18
100	22	53.5	50.5	M12 x 1.75	1/2-13UNC	22

Standard

Single Acting

Double Rod

Axial Piping

Water Resistant

High Lateral Load

End Lock

Clean Series

Copper/Fluorine free series

Construction and Parts

Warranty and Operating Instructions

Mounting and Operating Auto Switches

Made to Order

ø125 to ø160

Standard (Through hole): (N)C□Q2B

The dimensions are the same with or without an auto switch.

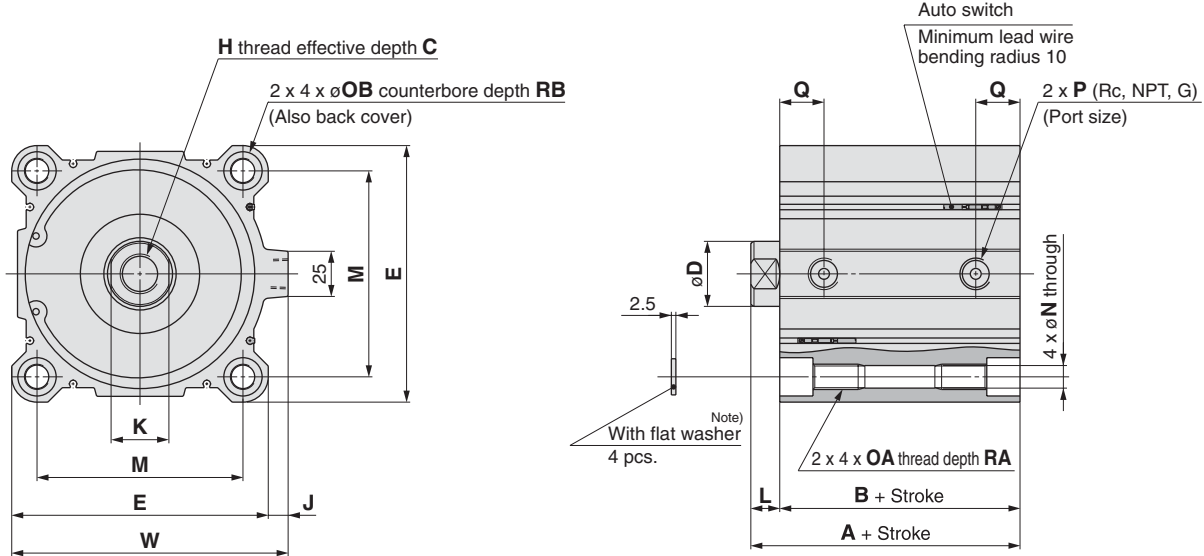

Rod end male thread

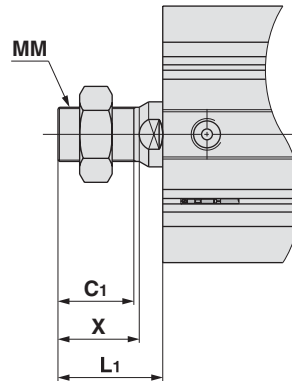

CQ2 Rod End Male Thread

Bore size (mm)	A1	C1	MM	L1	X
125	141	42	M30 x 1.5	58	45
140	141	42	M30 x 1.5	58	45
160	155	47	M36 x 1.5	64	50

NCQ2 Rod End Male Thread

Bore size (mm)	A1	C1	MM inch	L1	X
125	141	42	1-1/4-12UNF	58	45
140	141	42	1-1/4-12UNF	58	45
160	155	47	1-3/8-12UNF	64	50

Bore size (mm)	Standard stroke range	A	B	C	D	E	F	CQ2 H	NCQ2 H inch	I	J	K	L	M	N
125	10, 20, 30, 40, 50	99	83	30	36	142	24.5	M22 x 2.5	3/4-16UNF	190	11	32	16	114	12.5
140	75, 100, 125, 150	99	83	30	36	158	24.5	M22 x 2.5	3/4-16UNF	210	10	32	16	128	12.5
160	175, 200, 250, 300	108	91	33	40	178	27.5	M24 x 3	3/4-16UNF	238	10	36	17	144	14.5

Bore size (mm)	CQ2 OA	NCQ2 OA inch	OB	CQ2 P	NCQ2 P	Q	RA	RB	S	U
125	M14 x 2	9/16-12UNC	21.2	Rc 3/8	NPT 3/8	24.5	25	18.4	162	80
140	M14 x 2	9/16-12UNC	21.2	Rc 3/8	NPT 3/8	24.5	25	18.4	177	88
160	M16 x 2	5/8-11UNC	24.2	Rc 3/8	NPT 3/8	27.5	28	21.2	197	98

Note) Be sure to use the attached plain washer for mounting, cylinder with through-holes.

ø180, ø200

ø180

The dimensions are the same with or without an auto switch.

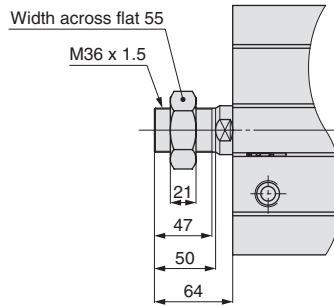
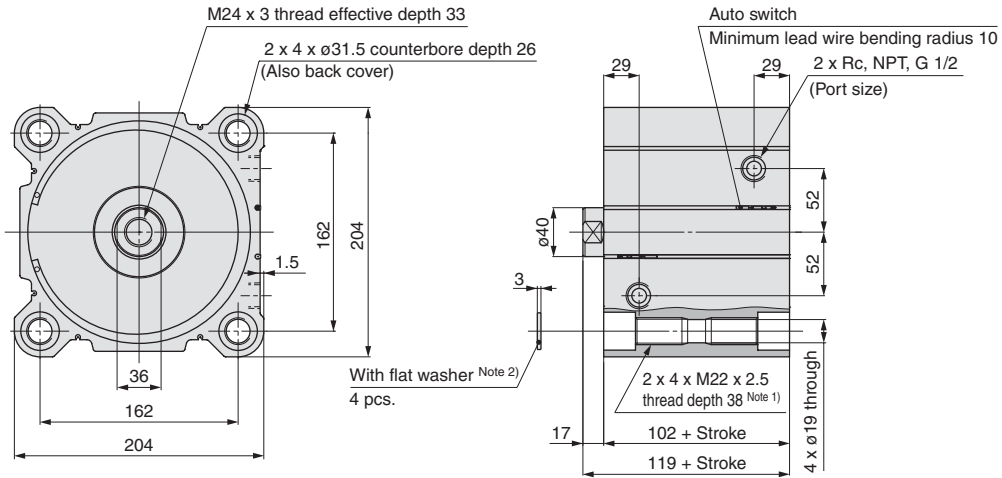

Note 1) In the case of 20 mm stroke or less, it would come with 2 x 4 x M22 x 2.5 through thread.
Note 2) Be sure to use the attached flat washer for mounting cylinder with through-holes.

ø200

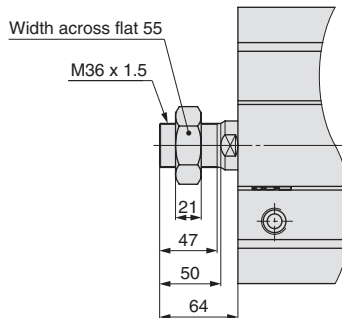
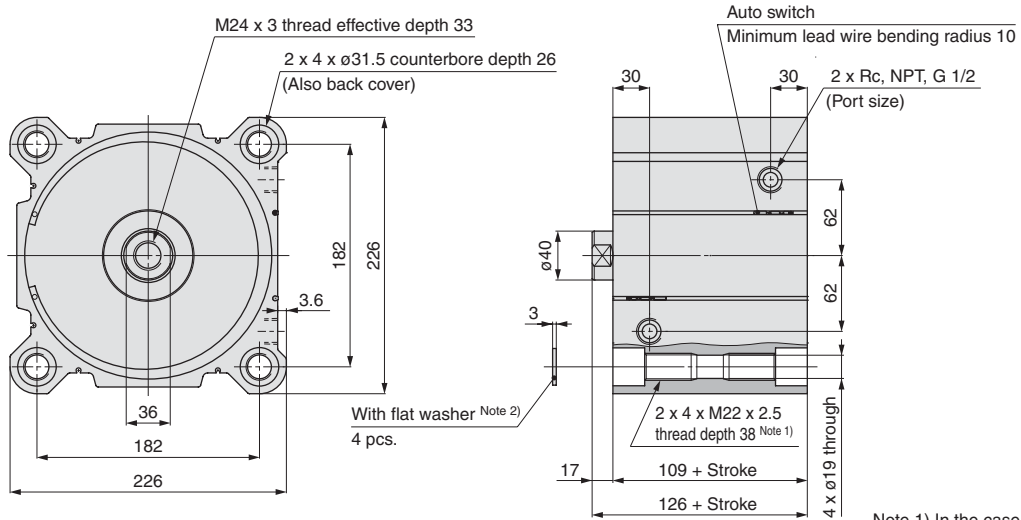

Note 1) In the case of 20 mm stroke or less, it would come with 2 x 4 x M22 x 2.5 through thread.
Note 2) Be sure to use the attached flat washer for mounting cylinder with through-holes.

Standard
Single Acting
Double Rod
Axial Piping
Water Resistant
High Lateral Load
End Lock
Clean Series
Copper/Fluorine free series
Construction and Parts
Warranty and Operating Instructions
Mounting and Auto Switches
Made to Order

ø12 to ø25 - Without Auto Switch

Standard (Through-hole): (N)CQ2KB

ø12, ø16

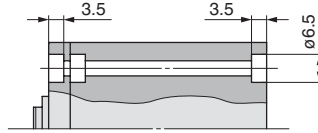

ø20, ø25

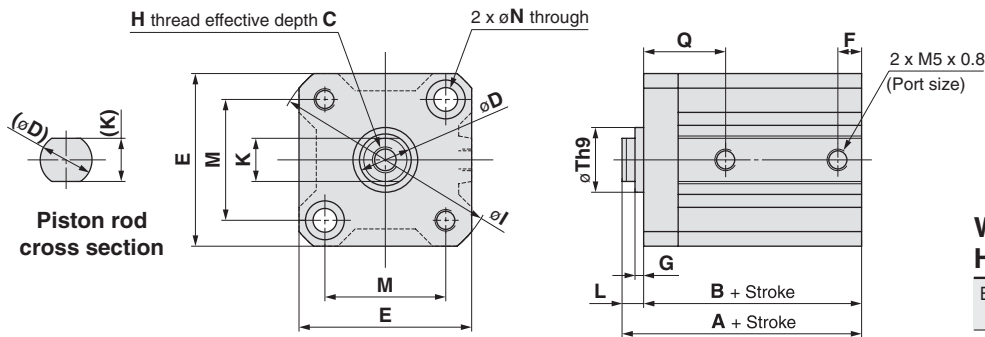
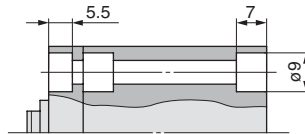

With Boss in Head Side (CQ2 only)

Bore size (mm)	G	Th9
12	1.5	15 ⁰ _{-0.043}
16	1.5	20 ⁰ _{-0.052}
20	2	13 ⁰ _{-0.043}
25	2	15 ⁰ _{-0.043}

With boss on head end

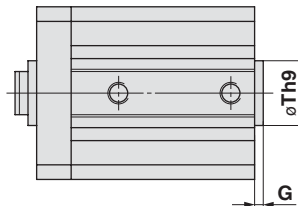

Rod end male thread

CQ2 Rod End Male Thread

Bore size (mm)	C ₁	MM	L ₁	X
12	9	M5 x 0.8	14	10.5
16	10	M6 x 1.0	15.5	12
20	12	M8 x 1.25	18.5	14
25	15	M10 x 1.25	22.5	17.5

NCQ2 Rod End Male Thread

Bore size (mm)	L ₁	MM inch	X
12	11.5	#8-32UNC	8
16	11.5	#8-32UNC	8
20	12.5	#10-32UNF	8
25	16.5	1/4-28UNF	9.5

"C₁" dim. not applicable

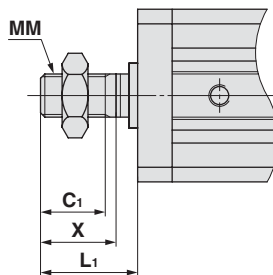

Basic Style

Bore size (mm)	Stroke range (mm)	A	B	CQ2 C	NCQ2 C	D	E	F	G	CQ2 H	NCQ2 H inch	I	K	L	M	N	Q	Th9
12	5 to 30	25.5	22	6	5.4	6	25	5	1.5	M3 x 0.5	#8-32UNC	32	5.2	3.5	15.5	3.5	12.5	15 ⁰ _{-0.043}
16	5 to 30	27	23.5	8	5.4	8	29	5.5	1.5	M4 x 0.7	#8-32UNC	38	6	3.5	20	3.5	13	20 ⁰ _{-0.052}
20	5 to 50	32	27.5	7	7	10	36	5.5	2	M5 x 0.8	#10-32UNF	47	8	4.5	25.5	5.5	17	13 ⁰ _{-0.043}
25	5 to 50	35.5	30.5	12	10	12	40	5.5	2	M6 x 1.0	1/4-28UNF	52	10	5	28	5.5	19	15 ⁰ _{-0.043}

* For details about the rod end nut and accessory brackets, refer to page 178.

ø12 to ø25 - With Auto Switch

Standard (Through-hole): (N)CDQ2KB ø12, ø16

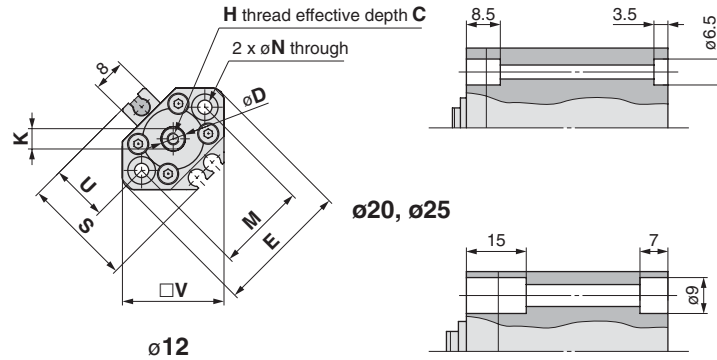

ø20, ø25

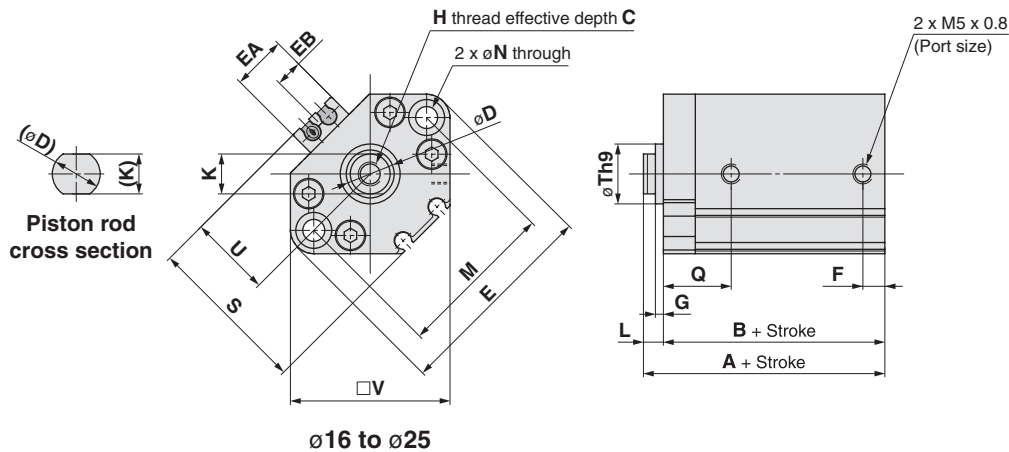
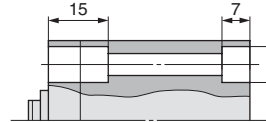

ø16 to ø25

With boss on head end

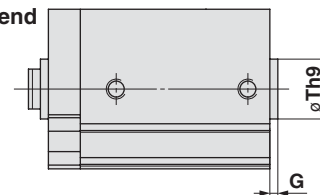

Rod end male thread

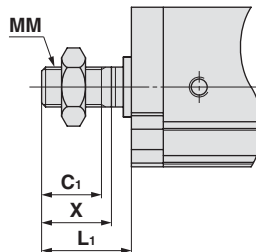

With Boss in Head Side (CQ2 only)

Bore size (mm)	G	Th9
12	1.5	15 ⁰ _{-0.043}
16	1.5	20 ⁰ _{-0.052}
20	2	13 ⁰ _{-0.043}
25	2	15 ⁰ _{-0.043}

CQ2 Rod End Male Thread

Bore size (mm)	C1	MM	L1	X
12	9	M5 x 0.8	14	10.5
16	10	M6 x 1.0	15.5	12
20	12	M8 x 1.25	18.5	14
25	15	M10 x 1.25	22.5	17.5

NCQ2 Rod End Male Thread

Bore size (mm)	MM inch	L1	X
12	#8-32UNC	11.5	8
16	#8-32UNC	11.5	8
20	#10-32UNF	12.5	8
25	1/4-28UNF	16.5	9.5

"C1" dim. not applicable

Basic Style

Bore size (mm)	Stroke range (mm)	A	B	CQ2 C	NCQ2 C	D	E	F	G	CQ2 H	NCQ2 H inch	K	L	M	N	Q	S	Th9	U	V
12	5 to 30	36.5	33	6	5.4	6	32	6.5	1.5	M3 x 0.5	#8-32UNC	5.2	3.5	22	3.5	16	35.5	15 ⁰ _{-0.043}	19.5	25
16	5 to 30	39	35.5	8	5.4	8	38	5.5	1.5	M4 x 0.7	#8-32UNC	6	3.5	28	3.5	15	41.5	20 ⁰ _{-0.052}	22.5	29
20	5 to 50	44	39.5	7	7	10	47	5.5	2	M5 x 0.8	#10-32UNF	8	4.5	36	5.5	18.5	48	13 ⁰ _{-0.043}	24.5	36
25	5 to 50	45.5	40.5	12	10	12	52	5.5	2	M6 x 1.0	1/4-28UNF	10	5	40	5.5	19	53.5	15 ⁰ _{-0.043}	27.5	40

* For details about the rod end nut and accessory brackets, refer to page 178.

Standard

Single Acting

Double Rod

Axial Piping

Water Resistant

High Lateral Load

End Lock

Clean Series

Copper/Fluorine free series

Construction and Parts

Warranty and Operating Instructions

Mounting and Auto Switches

Made to Order

Ø32 - Without Auto Switch

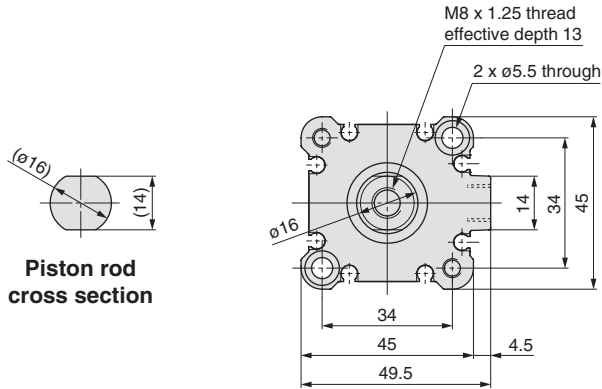

Piston rod cross section

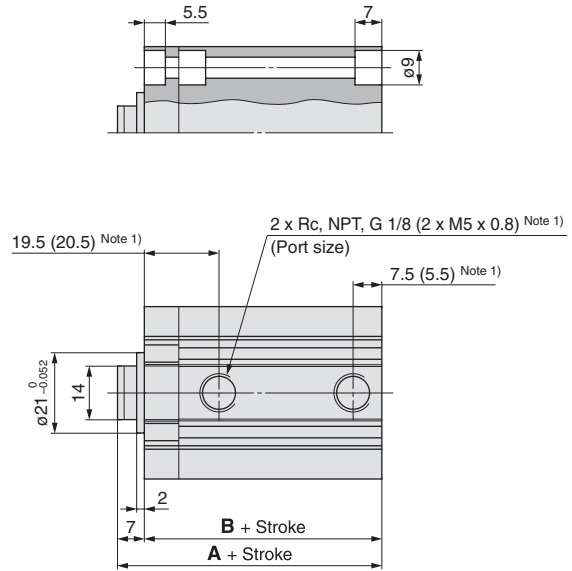

Note 1) () : Stroke 5 mm

Basic style

Stroke range	A	B	CQ2 P	NCQ2 P	CQ2 H	NCQ2 H inch	CQ2 C	NCQ2 C
5 to 50	39	32	Rc1/8	NPT1/8	M8 x 1.25	5/16-24UNF	13	13.3
75, 100	49	42	Rc1/8	NPT1/8				

(mm)

With boss on head end (CQ2 only)

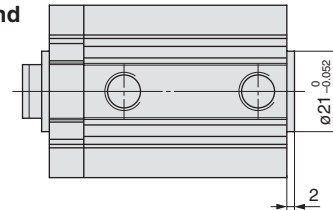

CQ2 Rod End Male Thread

Bore size (mm)	H1	L1	X	C1
32	M14 x 1.5	28.5	23.5	20.5

Rod end male thread

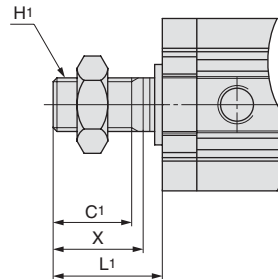

NCQ2 Rod End Male Thread

Bore size (mm)	H1 inch	L1	X
32	5/16-24UNF	17.7	12.7

"C1" dim not applicable

Built-in one-touch fittings: Ø32

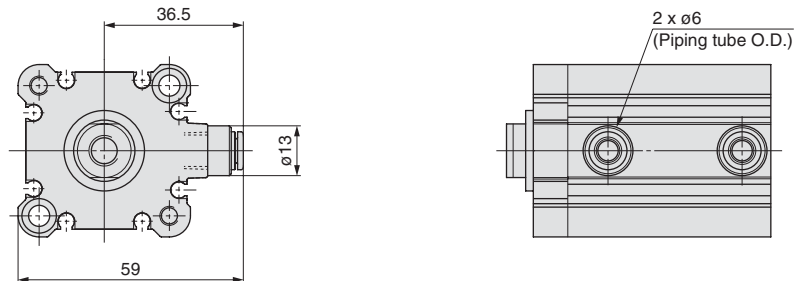

Note 2) The dimensions of the Ø32-5 mm stroke with built-in one-touch fittings are the same as those of the 10 mm stroke cylinder tube.

* For details about the rod end nut and accessory brackets, refer to page 178.

Ø32 - With Auto Switch

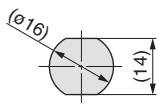

Piston rod cross section

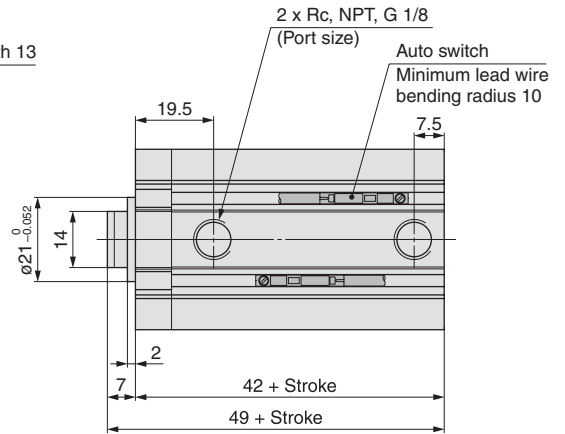
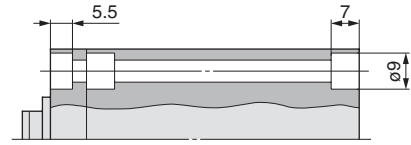
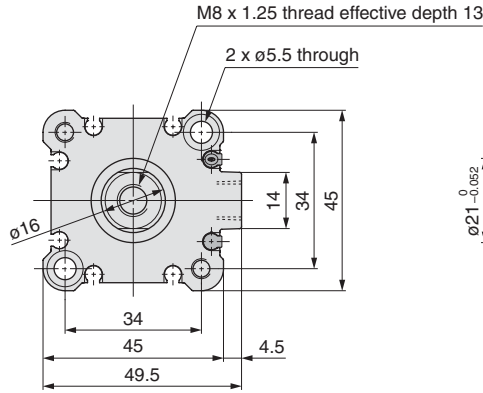

Basic style (mm)

Bore size (mm)	CQ2 P	NCQ2 P	CQ2 H	NCQ2 H inch	CQ2 C	NCQ2 C
32	Rc1/8	NPT1/8	M8 x 1.25	5/16-24UNF	13	13.3

CQ2 Rod End Male Thread

Bore size (mm)	H1	L1	X	C1
32	M14 x 1.5	28.5	23.5	20.5

NCQ2 Rod End Male Thread

Bore size (mm)	H1 inch	L1	X
32	5/16-24UNF	17.7	12.7

"C1" dim. not applicable

With boss on head end (CQ2 only)

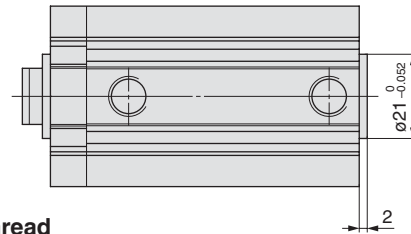

Rod end male thread

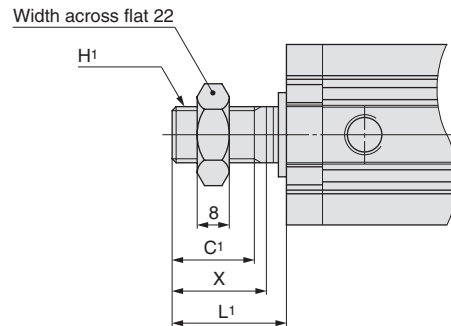

Built-in one-touch fittings: Ø32 (CQ2 only)

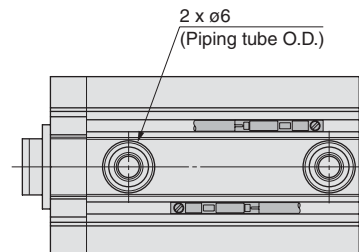
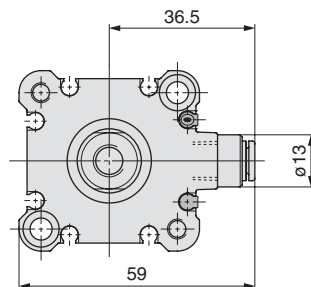

- Standard
- Single Acting
- Double Rod
- Axial Piping
- Water Resistant
- High Lateral Load
- End Lock
- Clean Series
- Copper/Fluorine free series
- Construction and Parts
- Warranty and Operating Instructions
- Mounting and Auto Switches
- Made to Order

Series (N)CQ2K

Double Acting, Single Rod
Dimensions - Non-Rotating Rod

ø40 to ø63 - With Auto Switch

(Without auto switches, only the A and B dimensions will be changed. Refer to the dimension table.)

Both ends tapped: CDQ2KA

Standard (Through-hole): (N)CDQ2KB

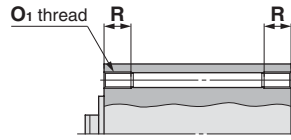
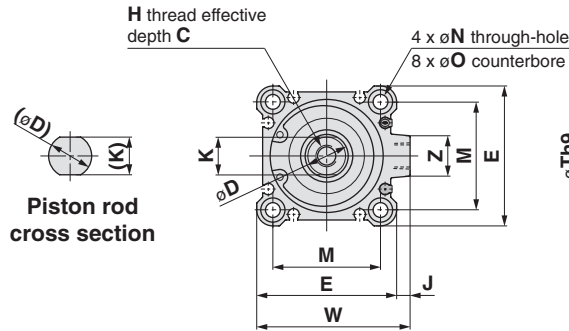

Both Ends Tapped Style

Bore size (mm)	CQ2 O ₁	NCQ2 O ₁ inch	R
40	M6 x 1.0	1/4-20UNC	10
50	M8 x 1.25	5/16-18UNC	14
63	M10 x 1.5	7/16-14UNC	18

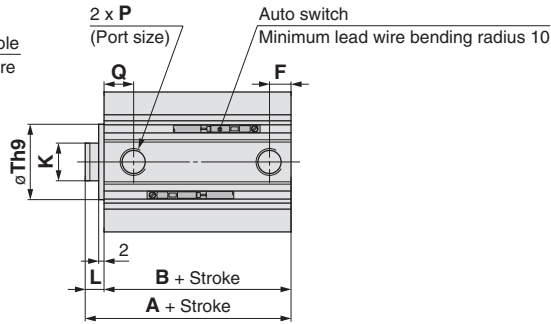

With boss on head end

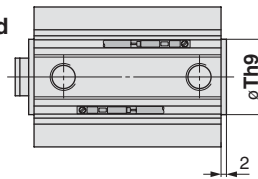

With Boss in Head Side (CQ2 only)

Bore size (mm)	Th9
40	28 ⁰ _{-0.052}
50	35 ⁰ _{-0.062}
63	35 ⁰ _{-0.062}

Rod end male thread

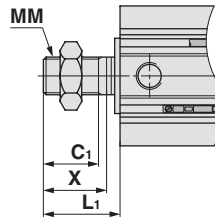
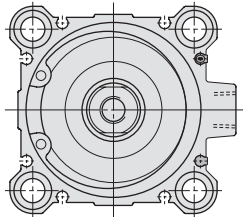

CQ2 Rod End Male Thread

Bore size (mm)	C ₁	MM	L1	X
40	20.5	M14 x 1.5	28.5	23.5
50	26	M18 x 1.5	33.5	28.5
63	26	M18 x 1.5	33.5	28.5

NCQ2 Rod End Male Thread

Bore size (mm)	MM inch	L1	X
40	3/8-24UNF	21	16
50	1/2-20UNF	23.5	19.5
63	1/2-20UNF	23.5	19.5

"C₁" dim. not applicable.

Cylinder tube form ø63

Built-in one-touch fittings: ø40 to ø63

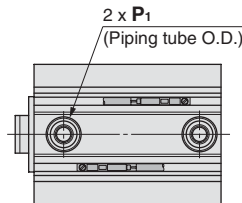
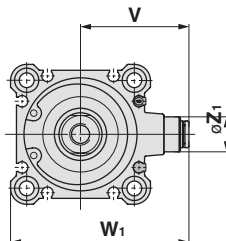

Built-in One-touch Fittings (CQ2 only)

Bore size (mm)	Z ₁	P ₁	V	W ₁
40	13	6	40.5	66.5
50	16	8	50	82
63	16	8	56.5	95

Basic Style

Bore size (mm)	Stroke range (mm)	Without auto switch		With auto switch		CQ2 C	NCQ2 C	D	E	F	CQ2 H	NCQ2 H inch	I	A	K	L	M	N	O	CQ2 P	NCQ2 P	Q	S	Th9	U	Z
		A	B	A	B																					
40	5 to 50	36.5	29.5	46.5	39.5	13	18.3	16	52	8	M8 x 1.25	3/8-24UNF	69	5	14	7	40	5.5	9 depth 7	Rc 1/8	NPT 1/8	11	66	28 ⁰ _{-0.052}	35	14
	75, 100	46.5	39.5																							
50	10 to 50	38.5	30.5	48.5	40.5	15	17.5	20	64	10.5	M10 x 1.5	1/2-20UNF	86	7	18	8	50	6.6	11 depth 8	Rc 1/4	NPT 1/4	10.5	80	35 ⁰ _{-0.062}	41	19
	75, 100	48.5	40.5																							
63	10 to 50	44	36	54	46	15	17.5	20	77	10.5	M10 x 1.5	1/2-20UNF	103	7	18	8	60	9	14 depth 10.5	Rc 1/4	NPT 1/4	15	93	35 ⁰ _{-0.062}	47.5	19
	75, 100	54	46																							

* For details about the rod end nut and accessory brackets, refer to page 178.

Foot: (N)C(D)Q2KL

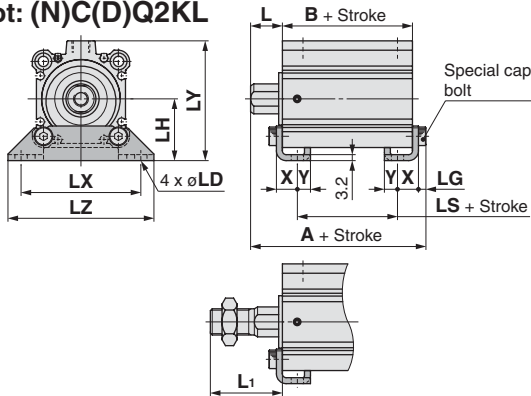

Rod flange: (N)C(D)Q2KF

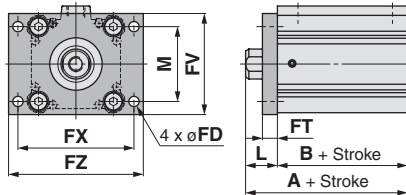

Rod end male thread

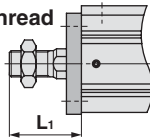

Head flange: (N)C(D)Q2KG

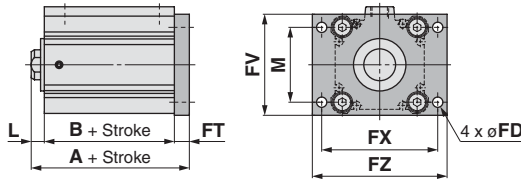

Rod end male thread

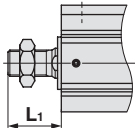

Double clevis: (N)C(D)Q2KD

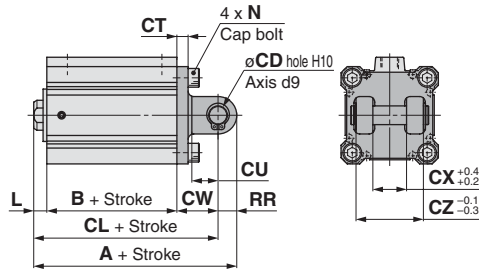

Rod end male thread

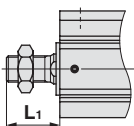

* For details about the rod end nut and accessory brackets, refer to page 178.
* Double clevis pin and retaining rings are included.

Foot Style

Bore size (mm)	Stroke range (mm)	Without auto switch			With auto switch			L	CQ2 L1	NCQ2 L1
		A	B	LS	A	B	LS			
40	5 to 50	53.7	29.5	13.5	63.7	39.5	23.5	17	38.5	31
	75, 100	63.7	39.5	23.5						
50	10 to 50	56.7	30.5	7.5	66.7	40.5	17.5	18	43.5	33.5
	75, 100	66.7	40.5	17.5						
63	10 to 50	62.2	36	10	72.2	46	20	18	43.5	33.5
	75, 100	72.2	46	20						

Bore size (mm)	LD	LG	LH	LX	LY	LZ	X	Y
40	6.6	4	33	64	64	78	11.2	7
50	9	5	39	79	78	95	14.7	8
63	11	5	46	95	91.5	113	16.2	9

Foot bracket material: Carbon steel

Rod Side Flange Style

Bore size (mm)	Stroke range (mm)	Without auto switch		With auto switch		FD	FT	FV	FX	FZ	L
		A	B	A	B						
40	5 to 50	46.5	29.5	56.5	39.5	5.5	8	54	62	72	17
	75, 100	56.5	39.5								
50	10 to 50	48.5	30.5	58.5	40.5	6.6	9	67	76	89	18
	75, 100	58.5	40.5								
63	10 to 50	54	36	64	46	9	9	80	92	108	18
	75, 100	64	46								

Bore size (mm)	Stroke range (mm)	CQ2 L1	NCQ2 L1	M
40	5 to 50	38.5	31	40
	75, 100			
50	10 to 50	43.5	33.5	50
	75, 100			
63	10 to 50	43.5	33.5	60
	75, 100			

Flange bracket material: Carbon steel

Head Side Flange Style

Bore size (mm)	Stroke range (mm)	Without auto switch		With auto switch		L	CQ2 L1	NCQ2 L1
		A	B	A	B			
40	5 to 50	44.5	54.5	54.5	7	28.5	21	
	75, 100							
50	10 to 50	47.5	57.5	57.5	8	33.5	23.5	
	75, 100							
63	10 to 50	53	63	63	8	33.5	23.5	
	75, 100							

* Dimensions except A, L and L1 are the same as rod side flange style.

Flange bracket material: Carbon steel

Double Clevis Style

Bore size (mm)	Stroke range (mm)	Without auto switch			With auto switch			CQ2 CD	NCQ2 CD inch	CT	CU	CW	CX	CZ	L
		A	B	CL	A	B	CL								
40	5 to 50	68.5	29.5	58.5	78.5	39.5	68.5	10	3/8	6	14	22	18	36	7
	75, 100														
50	10 to 50	80.5	30.5	66.5	90.5	40.5	76.5	14	1/2	7	20	28	22	44	8
	75, 100														
63	10 to 50	88	36	74	98	46	84	14	1/2	8	20	30	22	44	8
	75, 100														

Bore size (mm)	CQ2 L1	NCQ2 L1	CQ2 N	NCQ2 N inch	RR
40	28.5	21	M6 x 1.0	1/4-20UNC	10
50	33.5	23.5	M8 x 1.25	5/16-18UNC	14
63	33.5	23.5	M10 x 1.5	7/16-14UNC	14

Double clevis bracket material: Carbon steel

Standard

Single Acting

Double Rod

Axial Piping

Water Resistant

High Lateral Load

End Lock

Clean Series

Copper/Fluorine free series

Construction and Parts

Warranty and Operating Instructions

Mounting and Auto Switches

Made to Order

How to Order

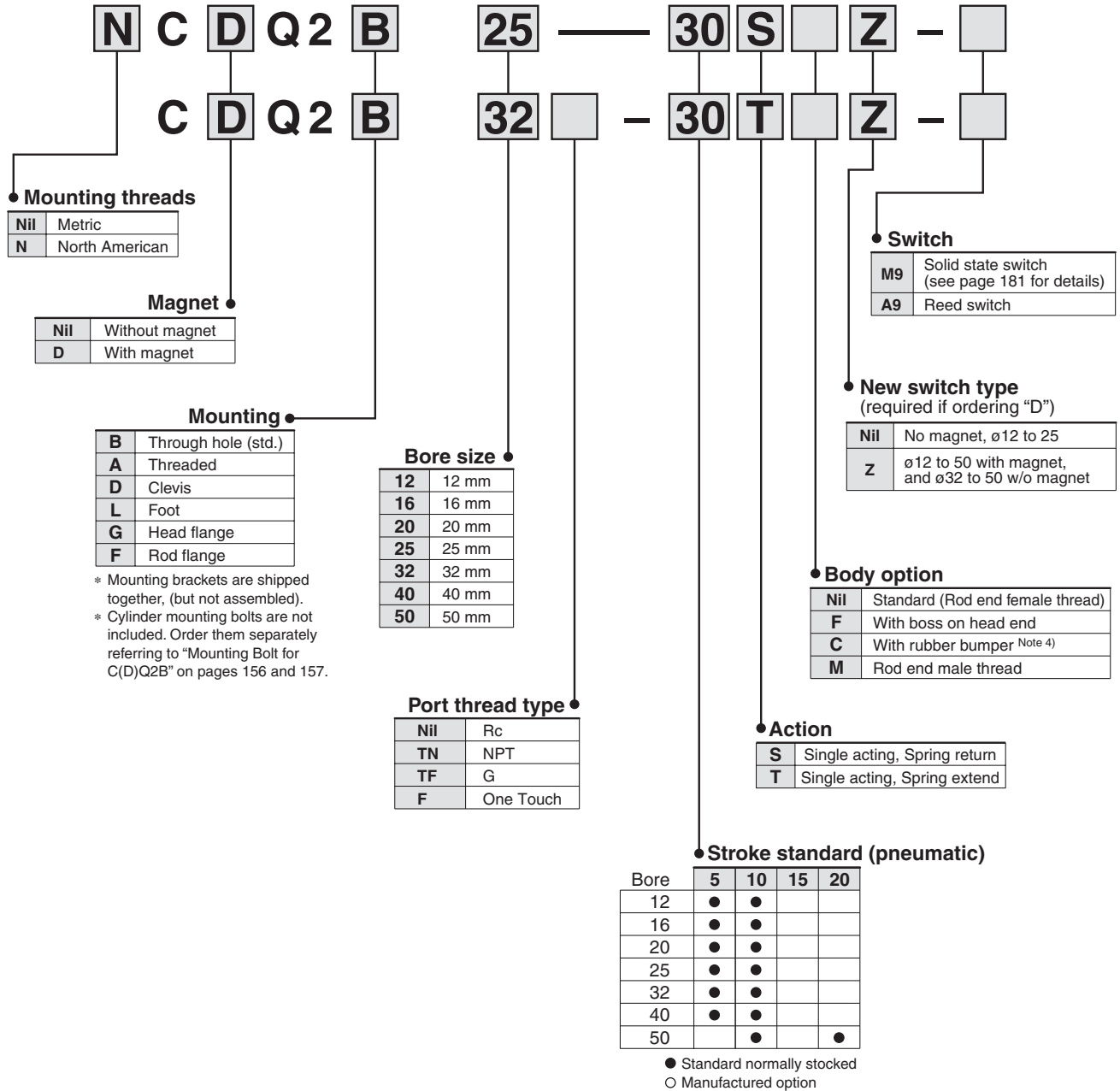

- Standard
- Single Acting
- Double Rod
- Axial Piping
- Water Resistant
- High Lateral Load
- End Lock
- Clean Series
- Copper/Fluorine free series
- Construction and Parts
- Warranty and Operating Instructions
- Mounting and Operating Auto Switches
- Made to Order



JIS Symbol

Single acting,
Spring return

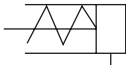

Single acting,
Spring extend

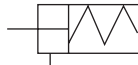

Specifications

Bore size (mm)	12	16	20	25	32	40	50
Action	Single acting, Single rod						
Fluid	Air						
Proof pressure	218 psi (1.5 MPa)						
Maximum operating pressure	145 psi (1.0 MPa)						
Minimum operating pressure (MPa)	0.25	0.25	0.18	0.18	0.17	0.15	0.13
Ambient and fluid temperature	Without auto switch: -10 to 70°C (No freezing) With auto switch: -10 to 60°C (No freezing)						
Lubrication	Not required (Non-lube)						
Piston speed	50 to 500 mm/s						
Allowable kinetic energy (J)	0.022	0.038	0.055	0.09	0.15	0.26	0.46
Stroke length tolerance	+1.0 mm 0						

Standard Strokes

Bore size	Standard stroke (mm)
12, 16, 20, 25, 32, 40	5, 10
50	10, 20

Manufacture of Intermediate Strokes (Except single acting, spring return type)

Type	A spacer is installed in the standard stroke body.	
Part no.	Refer to "How to Order" for the standard model number. (P. 31)	
Description	Strokes in 1 mm intervals are available by installing a spacer in the standard stroke cylinder.	
Stroke range	Bore size	Stroke range
	12 to 40	1 to 9
	50	1 to 19
Example	Part no.: CQ2B20-3T CQ2B20-5T with 2 mm width spacer inside The B dimension is 24.5 mm.	

Conversions

°F = 1.8°C + 32 1 J = 0.738 ft-lb
1 MPa = 145 psi 1 mm = 0.039 in

Spring Force

Single Acting, Spring Return (N)

Bore size (mm)	Stroke (mm)	Spring reaction force (N)	
		Second	First
12	5	13	8.6
	10	13	3.9
16	5	15	10.3
	10	15	5.9
20	5	15	10
	10	15	5.9
25	5	20	16
	10	20	11
32	5	30	23
	10	30	16
40	5	30	13
	10	39	21
50	10	50	30
	20	54	24

Single acting, Spring return

Spring state with first mounting load

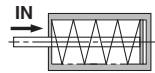

When spring is set in cylinder

Spring state with second mounting load

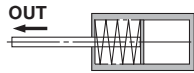

When spring is compressed with air

Minimum Operating Pressure

psi (MPa)

Bore size (mm)	Single acting (Spring return/extend)
12	36.3 (0.25)
16	36.3 (0.25)
20	26.1 (0.18)
25	26.1 (0.18)
32	24.7 (0.17)
40	21.8 (0.15)
50	18.9 (0.13)

Theoretical Output

(N)

Action	Bore size (mm)	Operating pressure (MPa)		
		0.3	0.5	0.7
Spring return	12	21	44	66
	16	45	86	126
	20	79	142	205
	25	126	224	323
	32	211	372	533
	40	338	589	841
Spring extend	12	14	31	48
	16	24	54	85
	20	44	91	138
	25	84	160	235
	32	152	273	393
	40	288	499	710
50	412	742	1072	

Weight

(g)

Single Acting, Spring Extend (N)

Bore size (mm)	Stroke (mm)	Spring reaction force (N)	
		Second	First
12	5	11	2.9
	10	9.7	2.8
16	5	20	3.9
	10	20	3.9
20	5	27	5.3
	10	27	5.9
25	5	29	9.8
	10	29	9.8
32	5	29	20
	10	29	20
40	5	29	20
	10	29	20
50	10	83	24
	20	83	24

Single acting, Spring extend

Spring state with first mounting load

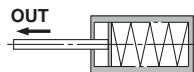

When spring is set in cylinder

Spring state with second mounting load

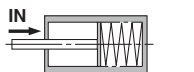

When spring is compressed with air

Action	Bore size (mm)	Cylinder stroke (mm)			
		5	10	15	20
Spring return	12	29	35	—	—
	16	42	51	—	—
	20	63	76	—	—
	25	87	101	—	—
	32	125	145	—	—
	40	196	217	—	—
Spring extend	12	—	357	—	426
	16	29	35	—	—
	20	43	50	—	—
	25	67	78	—	—
	32	92	104	—	—
	40	135	151	—	—
50	206	223	—	—	
		—	374	—	429

Additional Weight

(g)

Bore size (mm)		12	16	20	25	32	40	50
Both ends tapped		2	2	6	6	6	6	6
Rod end male thread	Male thread	1.5	3	6	12	26	27	53
	Nut	1	2	4	8	17	17	32
With boss on head end		0.7	1.3	2	3	5	7	13
Built-in one-touch fittings		—	—	—	—	6	6	10.5
Foot (Including mounting bolts)		55	67	164	186	142	154	243
Rod flange (Including mounting bolts)		57	69	139	161	180	214	373
Head flange (Including mounting bolts)		54	65	133	152	165	198	348
Double clevis (Including pin, retaining rings, bolts)		32	39	88	123	151	196	393

Calculation: (Example) CQ2D32-10SMZ

- Basic weight: CQ2B32-10SZ 145 g
 - Additional weight: Both ends tapped 6 g
 - Rod end male thread 43 g
 - Double clevis 151 g
- 345 g

Conversions

1g = 0.0353 oz 1 MPa = 145 psi 1 mm = 0.039 in
 1kg = 2.2046 lb 1J = 0.738 ft-lb 1N = 0.2248 lbf

Standard

Single Acting

Double Rod

Axial Piping

Water Resistant

High Lateral Load

End Lock

Clean Series

Copper/Fluorine free series

Construction and Parts

Warranty and Operating Instructions

Mounting and Auto Switches

Made to Order

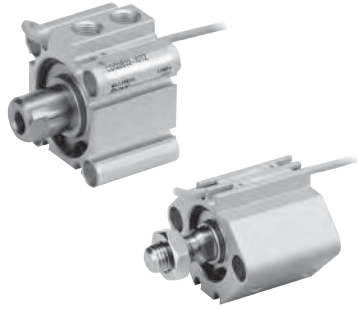

Refer to the below pages for further information on auto switches.

Auto switch proper mounting position and its mounting height	P.188 to 194
Minimum stroke for auto switch mounting	
Operating range	
Auto switch mounting brackets/Part no.	

Weight

Weight

(g)

Action	Bore size (mm)	Cylinder stroke (mm)			
		5	10	15	20
Spring return	12	44	49	—	—
	16	64	72	—	—
	20	97	109	—	—
	25	135	150	—	—
	32	182	202	—	—
	40	269	290	—	—
Spring extend	12	49	65	—	—
	16	63	71	—	—
	20	110	119	—	—
	25	149	163	—	—
	32	192	208	—	—
	40	279	296	—	—
	50	—	486	—	540

Additional Weight

(g)

Bore size (mm)	12	16	20	25	32	40	50
Both ends tapped	1	1	3	3	6	6	6
Rod end male thread	Male thread	1.5	3	6	12	26	53
	Nut	1	2	4	8	17	32
With boss on head end	0.7	1.3	2	3	5	7	13
Built-in one-touch fittings	—	—	—	—	6	6	10.5
Foot (Including mounting bolts)	49	62	147	169	142	154	243
Rod flange (Including mounting bolts)	54	67	131	153	180	214	373
Head flange (Including mounting bolts)	52	63	124	144	165	198	348
Double clevis (Including pin, retaining rings, bolts)	29	35	78	114	151	196	393

Calculation: (Example) **CDQ2D32-10SMZ**

- Basic weight: CDQ2B32-10SZ..... 202 g
- Additional weight: Both ends tapped..... 6 g
Rod end male thread.....43 g
Double clevis.....151 g
402 g

Add weight of each auto switch when auto switches are mounted.

1g = 0.0353 oz
1kg = 2.2046 lb

Series (N)CQ2

Single Acting, Single Rod
Dimensions - Standard

Ø12 to Ø25 Spring Return - Without Auto Switch

Standard (Through-hole): (N)CQ2B

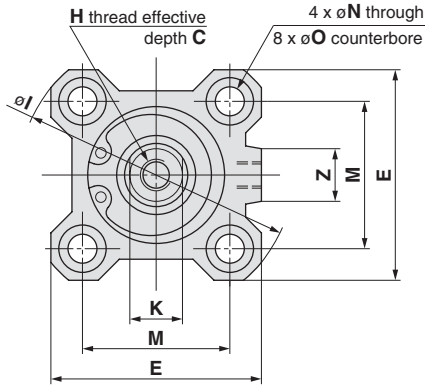

Both ends tapped: (N)CQ2A

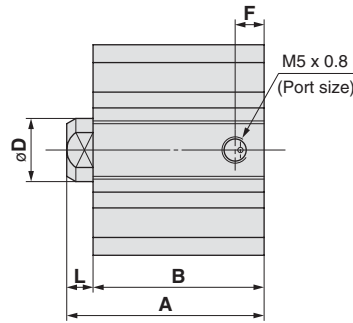
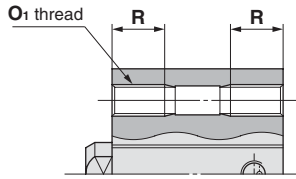

With boss on head end

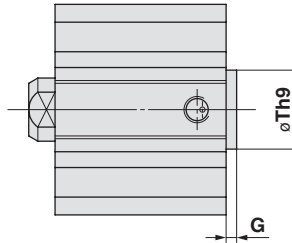

Rod end male thread

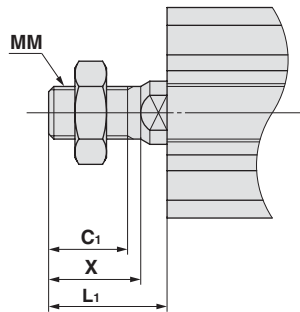

Both Ends Tapped Style

Bore size (mm)	CQ2 O ₁	NCQ2 O ₁ inch	R
12	M4 x 0.7	#8-32UNC	7
16	M4 x 0.7	#8-32UNC	7
20	M6 x 1.0	1/4-20UNC	10
25	M6 x 1.0	1/4-20UNC	10

With Boss on Head End (CQ2 Only)

Bore size (mm)	G	Th9 (mm)
12	1.5	15 ⁰ _{-0.043}
16	1.5	20 ⁰ _{-0.052}
20	2	13 ⁰ _{-0.043}
25	2	15 ⁰ _{-0.043}

Note) With boss on rod end: Option (Suffix "-XC36" to the end of model number.)

CQ2 Rod End Male Thread

Bore size (mm)	C ₁	X	MM	L ₁
12	9	10.5	M5 x 0.8	14
16	10	12	M6 x 1.0	15.5
20	12	14	M8 x 1.25	18.5
25	15	17.5	M10 x 1.25	22.5

NCQ2 Rod End Male Thread

Bore size (mm)	X	MM inch	L ₁
12	8	#8-32UNC	11.5
16	8	#8-32UNC	11.5
20	8	#10-32UNF	12.5
25	9.5	1/4-28UNF	14.5

*"C1" dim. not applicable.

Basic Style

Bore size (mm)	A		B		CQ2 C	NCQ2 C	D	E	F	CQ2 H	NCQ2 H inch	I	K	L	M	N	O	Z
	5 st	10 st	5 st	10 st														
12	25.5	30.5	22	27	6	5.4	6	25	5	M3 x 0.5	#8-32UNC	32	5	3.5	15.5	3.5	6.5 depth 3.5	—
16	27	32	23.5	28.5	8	5.4	8	29	5.5	M4 x 0.7	#8-32UNC	38	6	3.5	20	3.5	6.5 depth 3.5	10
20	29	34	24.5	29.5	7	7	10	36	5.5	M5 x 0.8	#10-32UNF	47	8	4.5	25.5	5.5	9 depth 7	10
25	32.5	37.5	27.5	32.5	12	10	12	40	5.5	M6 x 1.0	1/4-28UNF	52	10	5	28	5.5	9 depth 7	10

* For details about the rod end nut and accessory brackets, refer to page 178.

Foot: (N)CQ2L

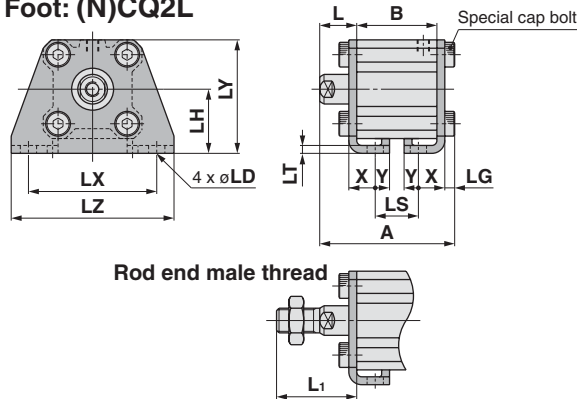

Rod end male thread

Rod flange: (N)CQ2F

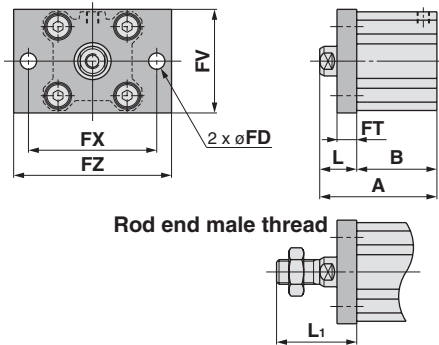

Rod end male thread

Head flange: (N)CQ2G

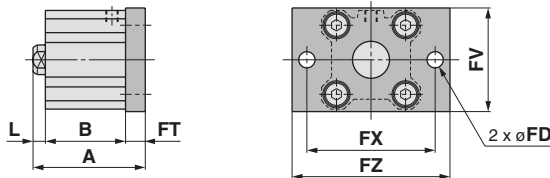

Rod end male thread

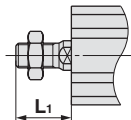

Double clevis: (N)CQ2D

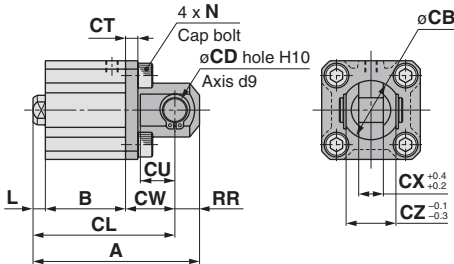

Rod end male thread

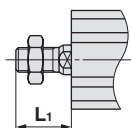

Foot Style

Bore size (mm)	A		B		L	CQ2 L1	NCQ2 L1	LD	LG	LH
	5 st	10 st	5 st	10 st						
12	40.3	45.3	22	27	13.5	24	21.5	4.5	2.8	17
16	41.8	46.8	23.5	28.5	13.5	25.5	21.5	4.5	2.8	19
20	46.2	51.2	24.5	29.5	14.5	28.5	22.5	6.6	4	24
25	49.7	54.7	27.5	32.5	15	32.5	24.5	6.6	4	26

Bore size (mm)	LS		LT	LX	LY	LZ	X	Y
	5 st	10 st						
12	10	15	2	34	29.5	44	8	4.5
16	11.5	16.5	2	38	33.5	48	8	5
20	12.5	17.5	3.2	48	42	62	9.2	5.8
25	12.5	17.5	3.2	52	46	66	10.7	5.8

Foot bracket material: Carbon steel

Rod Side Flange Style

Bore size (mm)	A		B		FD	FT	FV	FX	FZ	L	CQ2 L1	NCQ2 L1
	5 st	10 st	5 st	10 st								
12	35.5	40.5	22	27	4.5	5.5	25	45	55	13.5	24	21.5
16	37	42	23.5	28.5	4.5	5.5	30	45	55	13.5	25.5	21.5
20	39	44	24.5	29.5	6.6	8	39	48	60	14.5	28.5	22.5
25	42.5	47.5	27.5	32.5	6.6	8	42	52	64	15	32.5	24.5

Flange bracket material: Carbon steel

Head Side Flange Style

Bore size (mm)	A		L	CQ2 L1	NCQ2 L1
	5 st	10 st			
12	31	36	3.5	14	11.5
16	32.5	37.5	3.5	15.5	11.5
20	37	42	4.5	18.5	12.5
25	40.5	45.5	5	22.5	14.5

Flange bracket material: Carbon steel

(*Dimensions except A, L and L1 are the same as rod side flange style.)

Double Clevis Style

Bore size (mm)	A		B		CB	CQ2 CD	NCQ2 CD inch	CL		CT	CU
	5 st	10 st	5 st	10 st							
12	45.5	50.5	22	27	12	5	3/16	39.5	44.5	4	7
16	48	53	23.5	28.5	14	5	3/16	42	47	4	10
20	56	61	24.5	29.5	20	8	5/16	47	52	5	12
25	62.5	67.5	27.5	32.5	24	10	3/8	52.5	57.5	5	14

Bore size (mm)	CW	CX	CZ	L	CQ2 L1	NCQ2 L1	CQ2 N	NCQ2 N inch	RR
16	15	6.5	12	3.5	15.5	11.5	M4 x 0.7	#8-32UNC	6
20	18	8	16	4.5	18.5	12.5	M6 x 1.0	1/4-20UNC	9
25	20	10	20	5	22.5	14.5	M6 x 1.0	1/4-20UNC	10

Double clevis bracket material: Carbon steel

* For details about the rod end nut and accessory brackets, refer to pages 178.

** Clevis pin and snap ring are shipped together.

Standard

Single Acting

Double Rod

Axial Piping

Water Resistant

High Lateral Load

End Lock

Clean Series

Copper/Fluorine free series

Construction and Parts

Warranty and Operating Instructions

Mounting and Auto Switches

Made to Order

ø12 to ø25 Spring Return - With Auto Switch

Standard (Through-hole): (N)CDQ2B

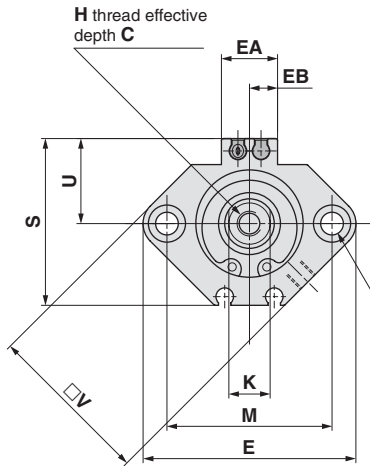

ø16 to ø25

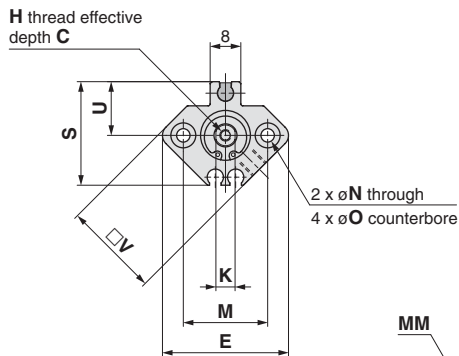

ø12

Both ends tapped: CDQ2A

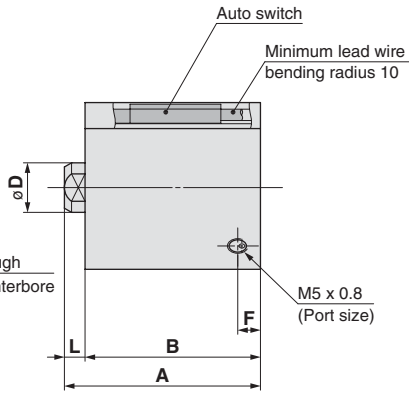
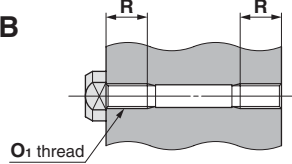

With boss on head end

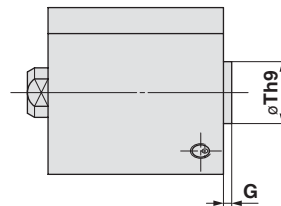

Rod end male thread

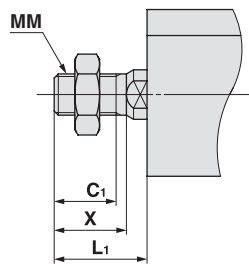

Both Ends Tapped Style

Bore size (mm)	CQ2 O ₁	NCQ2 O ₁ inch	R
12	M4 x 0.7	#8-32UNC	7
16	M4 x 0.7	#8-32UNC	7
20	M6 x 1.0	1/4-20UNC	10
25	M6 x 1.0	1/4-20UNC	10

With Boss in Head Side (CQ2 only)

Bore size (mm)	G	Th9
12	1.5	15 ⁰ _{-0.043}
16	1.5	20 ⁰ _{-0.052}
20	2	13 ⁰ _{-0.043}
25	2	15 ⁰ _{-0.043}

CQ2 Rod End Male Thread

Bore size (mm)	C1	X	MM	L1
12	9	10.5	M5 x 0.8	14
16	10	12	M6 x 1.0	15.5
20	12	14	M8 x 1.25	18.5
25	15	17.5	M10 x 1.25	22.5

NCQ2 Rod End Male Thread

Bore size (mm)	X	MM inch	L1
12	8	#8-32UNC	11.5
16	8	#8-32UNC	11.5
20	8	#10-32UNF	12.5
25	9.5	1/4-28UNF	14.5

*C1" dim. not applicable.

Basic Style

Bore size (mm)	A		B		CQ2 C	NCQ2 C	D	E	F	CQ2 H	NCQ2 H ₁ inch	K	L	M	N	O	S	U	V
	5 st	10 st	5 st	10 st															
12	36.5	41.5	33	38	6	5.4	6	32	6.5	M3 x 0.5	#8-32UNC	5	3.5	22	3.5	6.5 depth 3.5	35.5	19.5	25
16	39	44	35.5	40.5	8	5.4	8	38	5.5	M4 x 0.7	#8-32UNC	6	3.5	28	3.5	6.5 depth 3.5	41.5	22.5	29
20	41	46	36.5	41.5	7	7	10	47	5.5	M5 x 0.8	#10-32UNF	8	4.5	36	5.5	9 depth 7	48	24.5	36
25	42.5	47.5	37.5	42.5	12	10	12	52	5.5	M6 x 1.0	1/4-28UNF	10	5	40	5.5	9 depth 7	53.5	27.5	40

* For details about the rod end nut and accessory brackets, refer to page 178.

Foot: (N)CDQ2L

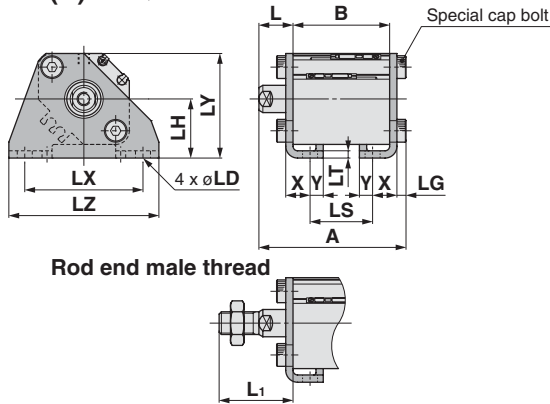

Foot Style

Bore size (mm)	A		B		L	CQ2 L1	NCQ2 L1	LD	LG	LH	LS	
	5 st	10 st	5 st	10 st							5 st	10 st
12	51.3	56.3	33	38	13.5	24	21.5	4.5	2.8	17	21	26
16	53.8	58.8	35.5	40.5	13.5	25.5	21.5	4.5	2.8	19	23.5	28.5
20	58.2	63.2	36.5	41.5	14.5	28.5	22.5	6.6	4	24	24.5	29.5
25	59.7	64.7	37.5	42.5	15	32.5	24.5	6.6	4	26	22.5	27.5

Bore size (mm)	LT	LX	LY	LZ	X	Y
12	2	34	29.5	44	8	4.5
16	2	38	33.5	48	8	5
20	3.2	48	42	62	9.2	5.8
25	3.2	52	46	66	10.7	5.8

Foot bracket material: Carbon steel

Rod flange: (N)CDQ2F

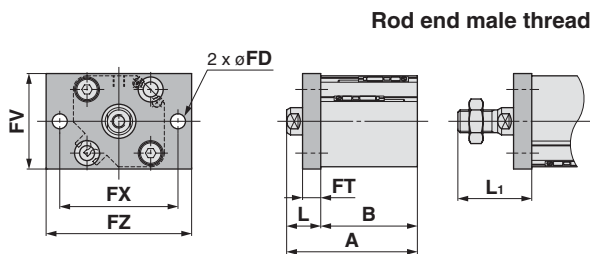

Rod Side Flange Style

Bore size (mm)	A		B		FD	FT	FV	FX	FZ	L	CQ2 L1	NCQ2 L1
	5 st	10 st	5 st	10 st								
12	46.5	51.5	33	38	4.5	5.5	25	45	55	13.5	24	21.5
16	49	54	35.5	40.5	4.5	5.5	30	45	55	13.5	25.5	21.5
20	51	56	36.5	41.5	6.6	8	39	48	60	14.5	28.5	22.5
25	52.5	57.5	37.5	42.5	6.6	8	42	52	64	15	32.5	24.5

Flange bracket material: Carbon steel

Head flange: (N)CDQ2G

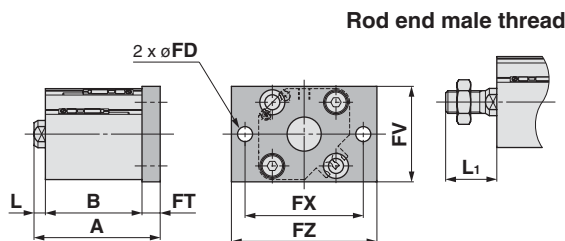

Head Side Flange Style

Bore size (mm)	A		L	CQ2 L1	NCQ2 L1
	5 st	10 st			
12	46.4	51.4	3.5	14	11.5
16	44.5	49.5	3.5	15.5	11.5
20	49	54	4.5	18.5	12.5
25	50.5	55.5	5	22.5	14.5

(* Dimensions except A, L and L1 are the same as rod side flange style.)

Flange bracket material: Carbon steel

Double clevis: (N)CDQ2D

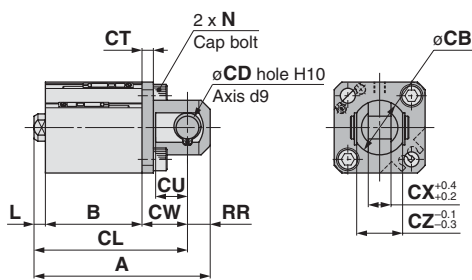

Double Clevis Style

Bore size (mm)	A		B		CB	CQ2 CD	NCQ2 CD inch	CL		CT	CU	CW	CX
	5 st	10 st	5 st	10 st				5 st	10 st				
12	56.5	61.5	33	38	12	5	3/16	50.5	55.5	4	7	14	5
16	60	65	35.5	40.5	14	5	3/16	54	59	4	10	15	6.5
20	68	73	36.5	41.5	20	8	5/16	59	64	5	12	18	8
25	72.5	77.5	37.5	42.5	24	10	3/8	62.5	67.5	5	14	20	10

Bore size (mm)	CZ	L	CQ2 L1	NCQ2 L1	CQ2 N	NCQ2 N inch	RR
12	10	3.5	14	11.5	M4 x 0.7	#8-32UNC	6
16	12	3.5	15.5	11.5	M4 x 0.7	#8-32UNC	6
20	16	4.5	18.5	12.5	M6 x 1.0	1/4-20UNC	9
25	20	5	22.5	14.5	M6 x 1.0	1/4-20UNC	10

Double clevis bracket material: Carbon steel

* For details about the rod end nut and accessory brackets, refer to page 178.

** Clevis pin and snap ring are shipped together.

Rod end male thread

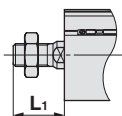

Standard

Single Acting

Double Rod

Axial Piping

Water Resistant

High Lateral Load

End Lock

Clean Series

Copper/Fluorine free series

Construction and Parts

Warranty and Operating Instructions

Mounting and Auto Switches

Made to Order

Series (N)CQ2

Single Acting, Single Rod

Dimensions - Standard

ø32 to ø50 Spring Return - With Auto Switch

(Without auto switches, only the A, B, F and P dimensions will be changed. Refer to the dimension table.)

Standard (Through-hole): (N)CQ2B/(N)CDQ2B

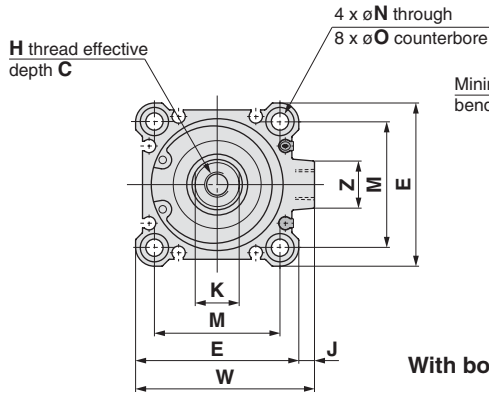

Both ends tapped: (N)CQ2A/(N)CDQ2A

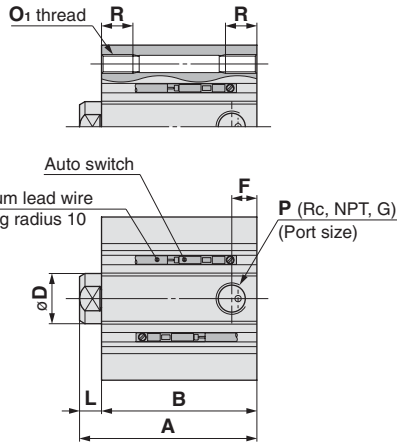

With boss on head end

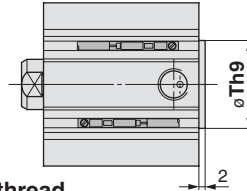

Rod end male thread

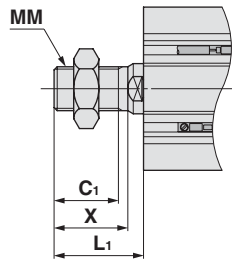

Built-in one-touch fittings: ø32 to ø50

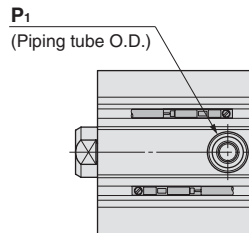
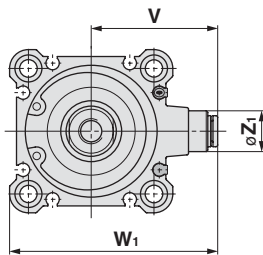

Both Ends Tapped Style

Bore size (mm)	CQ2 Ø1	NCQ2 Ø1 inch	R
32	M6 x 1.0	1/4-20UNC	10
40	M6 x 1.0	1/4-20UNC	10
50	M8 x 1.25	5/16-18UNC	14

With Boss in Head Side (CQ2 only)

Bore size (mm)	Th9
32	21 ⁰ _{-0.052}
40	28 ⁰ _{-0.052}
50	35 ⁰ _{-0.062}

CQ2 Rod End Male Thread

Bore size (mm)	C1	X	MM	L1
32	20.5	23.5	M14 x 1.5	28.5
40	20.5	23.5	M14 x 1.5	28.5
50	26	28.5	M18 x 1.5	33.5

NCQ2 Rod End Male Thread

Bore size (mm)	X	MM inch	L1
32	12.7	5/16-24UNF	19.7
40	16	3/8-24UNF	23
50	19.5	1/2-20UNF	27.5

*C1" dim. not applicable

Built-in One-touch Fittings (CQ2 only)

Bore size (mm)	Z1	P1	V	W1
32	13	6	36.5	59
40	13	6	40.5	66.5
50	16	8	50	82

Basic Style

Bore size (mm)	Without auto switch												With auto switch											
	A			B			F			CQ2 P			NCQ2 P			A			B			F	CQ2 P	NCQ2 P
5 st	10 st	20 st	5 st	10 st	20 st	5 st	10 st	20 st	5 st	10 st	20 st	5 st	10 st	20 st	5 st	10 st	20 st	5 st	10 st	20 st				
32	35	40	—	28	33	—	5.5	7.5	—	M5 x 0.8	Rc 1/8	—	M5 x 0.8	NPT 1/8	—	45	50	—	38	43	—	7.5	Rc1/8	NPT 1/8
40	41.5	46.5	—	34.5	39.5	—	8	8	—	Rc 1/8	—	—	NPT 1/8	—	51.5	56.5	—	44.5	49.5	—	8	Rc1/8	NPT 1/8	
50	—	48.5	58.5	—	40.5	50.5	—	10.5	10.5	—	Rc 1/4	—	NPT 1/4	—	58.5	68.5	—	50.5	60.5	10.5	Rc1/4	NPT 1/4		

Bore size (mm)	CQ2 C	NCQ2 C	D	E	CQ2 H	NCQ2 H1 inch	I	J	K	L	M	N	O	S	U	Z
32	13	13.3	16	45	M8 x 1.25	5/16-24UNF	60	4.5	14	7	34	5.5	9 depth 7	58.5	31.5	14
40	13	18.3	16	52	M8 x 1.25	3/8-24UNF	69	5	14	7	40	5.5	9 depth 7	66	35	14
50	15	17.5	20	64	M10 x 1.5	1/2-20UNF	86	7	17	8	50	6.6	11 depth 8	80	41	19

* For details about the rod end nut and accessory brackets, refer to page 178.

Note) A, B dimensions of ø32-5 stroke with One-touch fitting without auto switch are the same dimensions as the stroke ø32-10 without auto switch.

Foot: (N)CQ2L/(N)CDQ2L

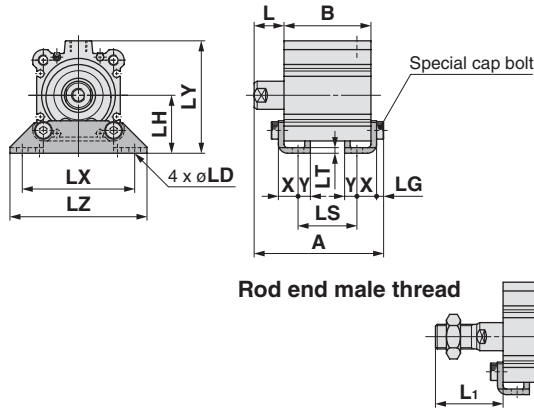

Foot Style

Bore size (mm)	Without auto switch						With auto switch												
	A		B		LS		A		B		LS								
	5 st	10 st	20 st	5 st	10 st	20 st	5 st	10 st	20 st	5 st	10 st	20 st							
32	52.5	57.2	—	28	33	—	12	17	—	62.2	67.2	—	38	43	—	22	27	—	
40	58.7	63.7	—	34.5	39.5	—	18.5	23.5	—	68.7	73.7	—	44.5	49.5	—	28.5	33.5	—	
50	—	66.7	76.7	—	40.5	50.5	—	17.5	27.5	—	76.7	86.7	—	50.5	60.5	—	27.5	37.5	—

Bore size (mm)	L	CQ2 L1	NCQ2 L1	LD	LG	LH	LX	LY	LZ	X	Y
32	17	38.5	29.7	6.6	4	30	57	57	71	11.2	5.8
40	17	38.5	33	6.6	4	33	64	64	78	11.2	7
50	18	43.5	37.5	9	5	39	79	78	95	14.7	8

Foot bracket material: Carbon steel

Rod flange: (N)CQ2F/(N)CDQ2F

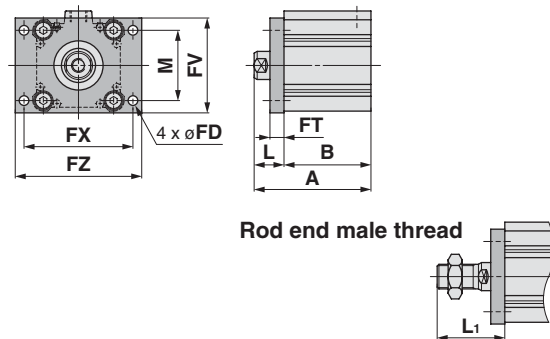

Rod Side Flange Style

Bore size (mm)	Without auto switch						With auto switch					
	A		B		A		B		A		B	
	5 st	10 st	20 st	5 st	10 st	20 st	5 st	10 st	20 st	5 st	10 st	20 st
32	45	50	—	28	33	—	55	60	—	38	43	—
40	51.5	56.5	—	34.5	39.5	—	61.5	66.5	—	44.5	49.5	—
50	—	58.5	68.5	—	40.5	50.5	—	68.5	78.5	—	50.5	60.5

Bore size (mm)	FD	FT	FV	FX	FZ	L	CQ2 L1	NCQ2 L1	M
32	5.5	8	48	56	65	17	38.5	29.7	34
40	5.5	8	54	62	72	17	38.5	33	40
50	6.6	9	67	76	89	18	43.5	37.5	50

Flange bracket material: Carbon steel

Head flange: (N)CQ2G/(N)CDQ2G

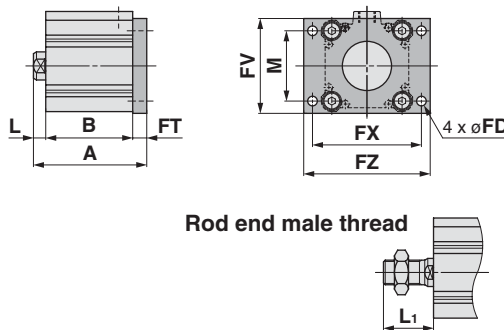

Head Side Flange Style

Bore size (mm)	Without auto switch						With auto switch						L	CQ2 L1	NCQ2 L1
	A			B			A			B					
	5 st	10 st	20 st	5 st	10 st	20 st	5 st	10 st	20 st	5 st	10 st	20 st	5 st	10 st	20 st
32	43	48	—	53	58	—	7	28.5	19.7	—	—	—	—	—	—
40	49.5	54.5	—	59.5	64.5	—	7	28.5	23	—	—	—	—	—	—
50	—	57.5	67.5	—	67.5	77.5	8	33.5	27.5	—	—	—	—	—	—

(*Dimensions except A, L and L1 are the same as rod side flange style.)

Flange bracket material: Carbon steel

Double clevis: (N)CQ2D/(N)CDQ2D

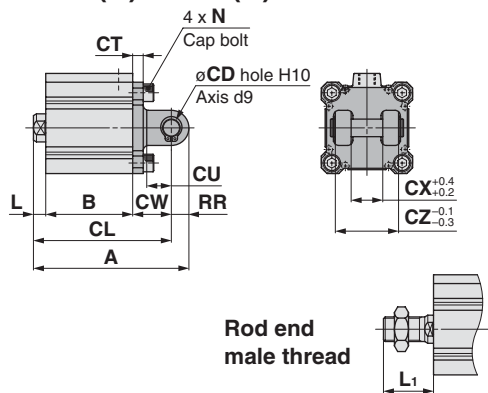

Double Clevis Style

Bore size (mm)	Without auto switch									With auto switch									
	A			B			CL			A			B			CL			
	5 st	10 st	20 st	5 st	10 st	20 st	5 st	10 st	20 st	5 st	10 st	20 st	5 st	10 st	20 st	5 st	10 st	20 st	
32	65	70	—	28	33	—	55	60	—	75	80	—	38	43	—	65	70	—	
40	73.5	78.5	—	39.5	39.5	—	63.5	68.5	—	83.5	88.5	—	44.5	49.5	—	73.5	78.5	—	
50	—	90.5	100.5	—	40.5	50.5	—	76.5	86.5	—	100.5	110.5	50.5	50.5	60.5	—	86.5	96.5	—

Bore size (mm)	CQ2 CD	NCQ2 CD inch	CT	CU	CW	CX	CZ	L	CQ2 L1	NCQ2 L1	CQ2 N	NCQ2 N inch	RR
32	10	3/8	5	14	20	18	36	7	28.5	19.7	M6 x 1.0	1/4-20UNC	10
40	10	3/8	6	14	22	18	36	7	28.5	23	M6 x 1.0	1/4-20UNC	10
50	14	1/2	7	20	28	22	44	8	33.5	27.5	M8 x 1.25	5/16-18UNC	14

Double clevis bracket material: Cast iron

* For details about the rod end nut and accessory brackets, refer to page 178.

** Clevis pin and snap ring are attached.

- Standard
- Single Acting
- Double Rod
- Axial Piping
- Water Resistant
- High Lateral Load
- End Lock
- Clean Series
- Copper/Fluorine free series
- Construction and Parts
- Warranty and Operating Instructions
- Mounting and Auto Switches
- Made to Order

ø12 to ø25 Spring Extend - Without Auto Switch

Standard (Through-hole): (N)CQ2B

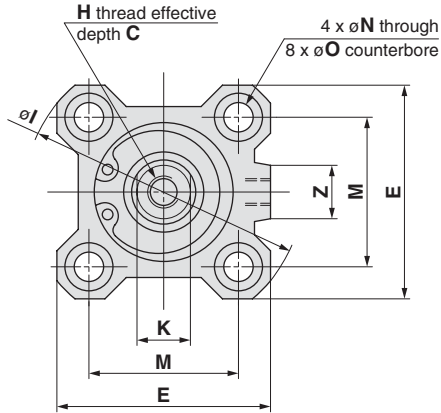

Both ends tapped: (N)CQ2A

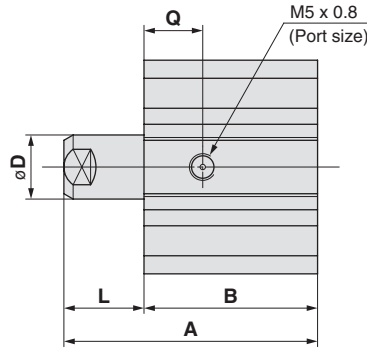
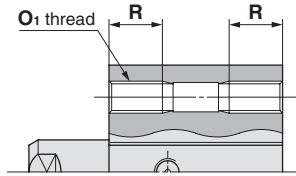

With boss on head end

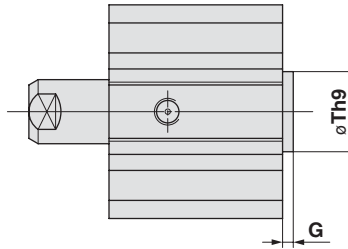

Rod end male thread

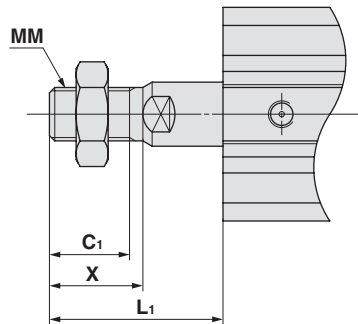

Both Ends Tapped Style

Bore size (mm)	CQ2 O1	NCQ2 O1 inch	R
12	M4 x 0.7	#8-32UNC	7
16	M4 x 0.7	#8-32UNC	7
20	M6 x 1.0	1/4-20UNC	10
25	M6 x 1.0	1/4-20UNC	10

With Boss in Head Side (CQ2 only)

Bore size (mm)	G	Th9
12	1.5	15 ⁰ _{-0.043}
16	1.5	20 ⁰ _{-0.052}
20	2	13 ⁰ _{-0.043}
25	2	15 ⁰ _{-0.043}

Note) With boss on rod end: Option (Suffix "-XC36" to the end of model number.)

CQ2 Rod End Male Thread

Bore size (mm)	C1	X	MM	L1	
				5 st	10 st
12	9	10.5	M5 x 0.8	19	24
16	10	12	M6 x 1.0	20.5	25.5
20	12	14	M8 x 1.25	23.5	28.5
25	15	17.5	M10 x 1.25	27.5	32.5

NCQ2 Rod End Male Thread

Bore size (mm)	X	MM inch	L1	
			5 st	10 st
12	8	#8-32UNC	16.5	21.5
16	8	#8-32UNC	16.5	21.5
20	8	#10-32UNF	17.5	22.5
25	9.5	1/4-28UNF	19.5	24.5

"C1" dim. not applicable

Basic Style

Bore size (mm)	A		B		CQ2 C	NCQ2 C	D	E	CQ2 H	NCQ2 H inch	I	K	L		M	N	O	Q	Z
	5 st	10 st	5 st	10 st									5 st	10 st					
12	30.5	40.5	22	27	6	5.4	6	25	M3 x 0.5	#8-32UNC	32	5	8.5	13.5	15.5	3.5	6.5 depth 3.5	7.5	—
16	32	42	23.5	28.5	8	5.4	8	29	M4 x 0.7	#8-32UNC	38	6	8.5	13.5	20	3.5	6.5 depth 3.5	8	10
20	34	44	24.5	29.5	7	7	10	36	M5 x 0.8	#10-32UNF	47	8	9.5	14.5	25.5	5.5	9 depth 7	9	10
25	37.5	47.5	27.5	32.5	12	10	12	40	M6 x 1.0	1/4-28UNF	52	10	10	15	28	5.5	9 depth 7	11	10

* For details about the rod end nut and accessory brackets, refer to page 178.

Foot: (N)CQ2L

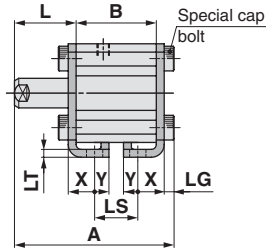
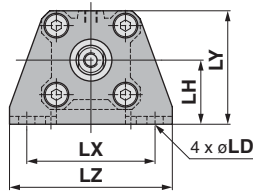

Rod end male thread

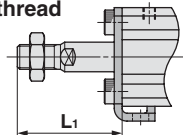

Rod flange: (N)CQ2F

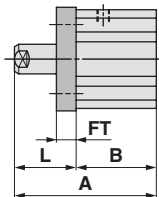
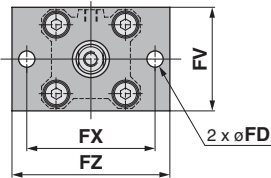

Rod end male thread

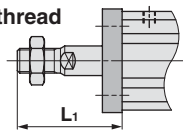

Head flange: (N)CQ2G

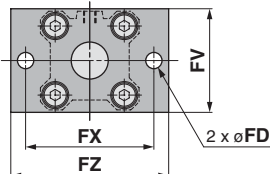
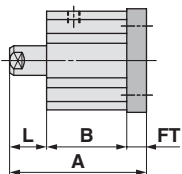

Rod end male thread

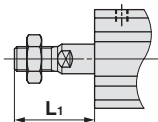

Double clevis: (N)CQ2D

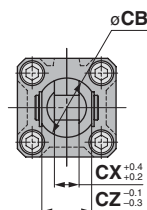
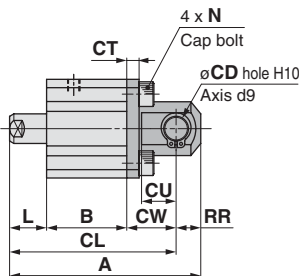

Rod end male thread

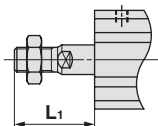

Foot Style

Bore size (mm)	A		B		L		CQ2 L1		NCQ2 L1		LD	LG	LH
	5 st	10 st	5 st	10 st	5 st	10 st	5 st	10 st	5 st	10 st			
12	45.3	55.3	22	27	18.5	23.5	29	34	26.5	31.5	4.5	2.8	17
16	46.8	56.8	23.5	28.5	18.5	23.5	30.5	35.5	26.5	31.5	4.5	2.8	19
20	51.2	61.2	24.5	29.5	19.5	24.5	33.5	38.5	27.5	32.5	6.6	4	24
25	54.7	64.7	27.5	32.5	20	25	37.5	42.5	29.5	34.5	6.6	4	26

Bore size (mm)	LS		LT	LX	LY	LZ	X	Y
	5 st	10 st						
12	10	15	2	34	29.5	44	8	4.5
16	11.5	16.5	2	38	33.5	48	8	5
20	12.5	17.5	3.2	48	42	62	9.2	5.8
25	12.5	17.5	3.2	52	46	66	10.7	5.8

Foot bracket material: Carbon steel

Rod Side Flange Style

Bore size (mm)	A		B		FD	FT	FV	FX	FZ
	5 st	10 st	5 st	10 st					
12	40.5	50.5	22	27	4.5	5.5	25	45	55
16	42	52	23.5	28.5	4.5	5.5	30	45	55
20	44	54	24.5	29.5	6.6	8	39	48	60
25	47.5	57.5	27.5	32.5	6.6	8	42	52	64

Bore size (mm)	L		CQ2 L1		NCQ2 L1	
	5 st	10 st	5 st	10 st	5 st	10 st
12	18.5	23.5	29	34	26.5	31.5
16	18.5	23.5	30.5	35.5	26.5	31.5
20	19.5	24.5	33.5	38.5	27.5	32.5
25	20	25	37.5	42.5	29.5	34.5

Flange bracket material: Carbon steel

Head Side Flange Style

Bore size (mm)	A		L		CQ2 L1		NCQ2 L1	
	5 st	10 st	5 st	10 st	5 st	10 st	5 st	10 st
12	36	46	8.5	13.5	19	24	16.5	21.5
16	37.5	47.5	8.5	13.5	20.5	25.5	16.5	21.5
20	42	52	9.5	14.5	23.5	28.5	17.5	22.5
25	45.5	55.5	10	15	27.5	32.5	19.5	24.5

* Dimensions except A, L and L1 are the same as rod side flange style.

Flange bracket material: Carbon steel

Double Clevis Style

Bore size (mm)	A		B		CB	CQ2 CD	NCQ2 CD inch	CL		CT	CU	CW
	5 st	10 st	5 st	10 st				5 st	10 st			
12	50.5	60.5	22	27	12	5	3/16	44.5	54.5	4	7	14
16	53	63	23.5	28.5	14	5	3/16	47	57	4	10	15
20	61	71	24.5	29.5	20	8	5/16	52	62	5	12	18
25	67.5	77.5	27.5	32.5	24	10	3/8	57.5	67.5	5	14	20

Bore size (mm)	CX	CZ	L		CQ2 L1		NCQ2 L1		CQ2 N	NCQ2 N inch	RR
			5 st	10 st	5 st	10 st	5 st	10 st			
12	5	10	8.5	13.5	19	24	16.5	21.5	M4 x 0.7	#8-32UNC	6
16	6.5	12	8.5	13.5	20.5	25.5	16.5	21.5	M4 x 0.7	#8-32UNC	6
20	8	16	9.5	14.5	23.5	28.5	17.5	22.5	M6 x 1.0	#1/4-20UNC	9
25	10	20	10	15	27.5	32.5	19.5	24.5	M6 x 1.0	#1/4-20UNC	10

Double clevis bracket material: Carbon steel

Surface treatment: Nickel plated

* For details about the rod end nut and accessory brackets, refer to page 178.

* Double clevis pin and retaining rings are included.

- Standard
- Single Acting
- Double Rod
- Axial Piping
- Water Resistant
- High Lateral Load
- End Lock
- Clean Series
- Copper/Fluorine free series
- Construction and Parts
- Warranty and Operating Instructions
- Mounting and Auto Switches
- Made to Order

ø12 to ø25 Spring Extend - With Auto Switch

Standard (Through-hole): (N)CDQ2B

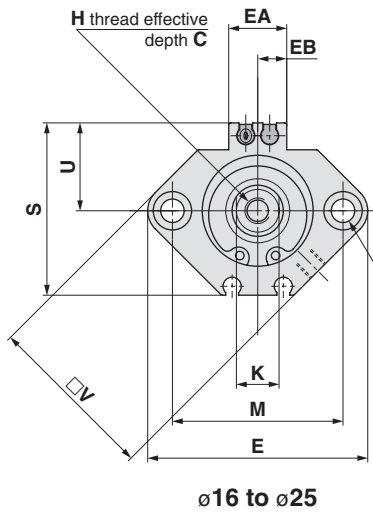

Both ends tapped: (N)CDQ2A

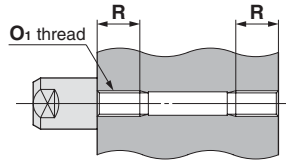

Both Ends Tapped Style

Bore size (mm)	CQ2 O1	NCQ2 O1 inch	R
12	M4 x 0.7	#8-32UNC	7
16	M4 x 0.7	#8-32UNC	7
20	M6 x 1.0	1/4-20UNC	10
25	M6 x 1.0	1/4-20UNC	10

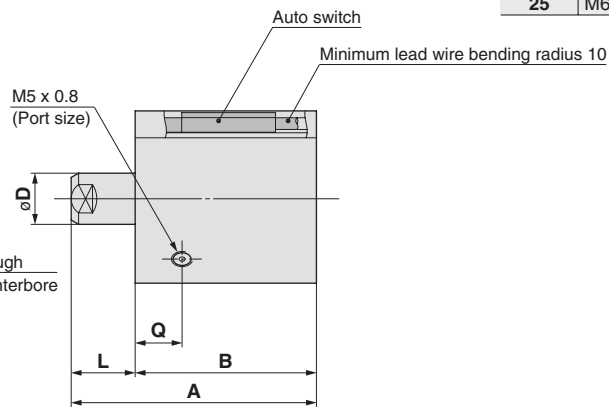

With boss on head end

With Boss in Head Side (CQ2 only)

Bore size (mm)	G	Th9
12	1.5	15 ⁰ _{-0.043}
16	1.5	20 ⁰ _{-0.052}
20	2	13 ⁰ _{-0.043}
25	2	15 ⁰ _{-0.043}

Note) With boss in rod side is also available. (Suffix "-XC36" to the end of model number.)

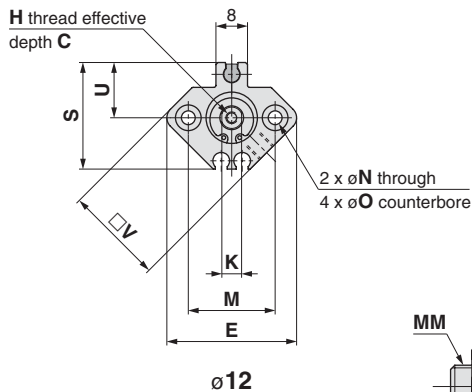

Rod end male thread

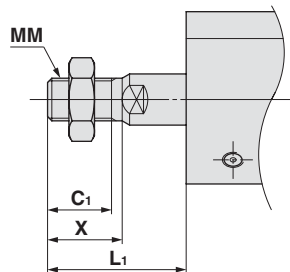

CQ2 Rod End Male Thread

Bore size (mm)	C1	X	MM	L1	
				5 st	10 st
12	9	10.5	M5 x 0.8	19	24
16	10	12	M6 x 1.0	20.5	25.5
20	12	14	M8 x 1.25	23.5	28.5
25	15	17.5	M10 x 1.25	27.5	32.5

NCQ2 Rod End Male Thread

Bore size (mm)	X	MM inch	L1	
			5 st	10 st
12	8	#8-32UNC	16.5	21.5
16	8	#8-32UNC	16.5	21.5
20	8	#10-32UNF	17.5	22.5
25	9.5	1/4-28UNF	19.5	24.5

"C1" dim. not applicable

Basic Style For auto switch proper mounting position and its mounting height, refer to pages 188 to 194.

Bore size (mm)	A		B		CQ2 C	NCQ2 C	D	E	CQ2 H	NCQ2 H inch	K	L		M	N	O	Q	S	U	V
	5 st	10 st	5 st	10 st								5 st	10 st							
12	45.9	55.9	37.4	42.4	6	5.4	6	32	M3 x 0.5	#8-32UNC	5	8.5	13.5	22	3.5	6.5 depth 3.5	11	35.5	19.5	25
16	44	54	35.5	40.5	8	5.4	8	38	M4 x 0.7	#8-32UNC	6	8.5	13.5	28	3.5	6.5 depth 3.5	10	41.5	22.5	29
20	46	56	36.5	41.5	7	7	10	47	M5 x 0.8	#10-32UNF	8	9.5	14.5	36	5.5	9 depth 7	10.5	48	24.5	36
25	47.5	57.5	37.5	42.5	12	10	12	52	M6 x 1.0	1/4-28UNF	10	10	15	40	5.5	9 depth 7	11	53.5	27.5	40

* For details about the rod end nut and accessory brackets, refer to page 178.

Foot: (N)CDQ2L

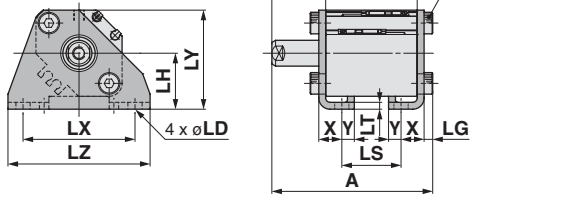

Rod end male thread

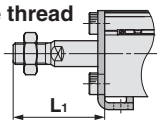

Rod flange: (N)CDQ2F

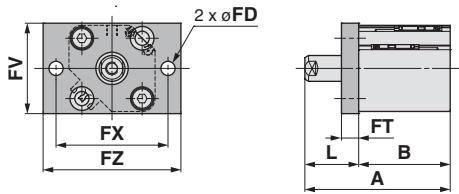

Rod end male thread

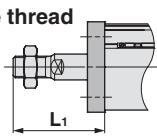

Head flange: (N)CDQ2G

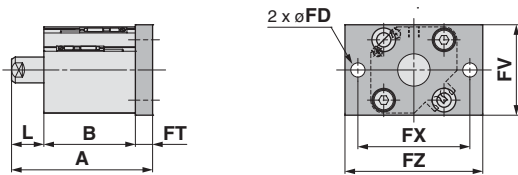

Rod end male thread

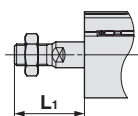

Double clevis: (N)CDQ2D

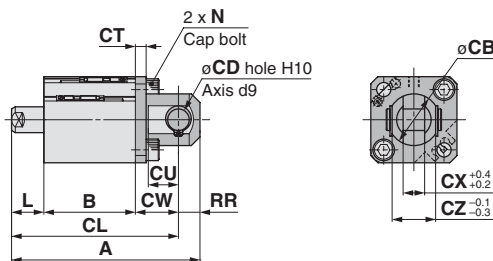

Rod end male thread

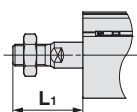

Foot Style

Bore size (mm)	A		B		L		CQ2 L ₁		NCQ2 L ₁		LD	LG	LH
	5 st	10 st	5 st	10 st	5 st	10 st	5 st	10 st	5 st	10 st			
12	60.7	70.7	37.4	42.4	18.5	23.5	29	34	26.5	31.5	4.5	2.8	17
16	58.8	68.8	35.5	40.5	18.5	23.5	30.5	35.5	26.5	31.5	4.5	2.8	19
20	63.2	73.2	36.5	41.5	19.5	24.5	33.5	38.5	27.5	32.5	6.6	4	24
25	64.7	74.7	37.5	42.5	20	25	37.5	42.5	29.5	34.5	6.6	4	26

Bore size (mm)	LS		LT	LX	LY	LZ	X	Y
	5 st	10 st						
12	25.4	30.4	2	34	29.5	44	8	4.5
16	23.5	28.5	2	38	33.5	48	8	5
20	24.5	29.5	3.2	48	42	62	9.2	5.8
25	22.5	27.5	3.2	52	46	66	10.7	5.8

Foot bracket material: Carbon steel

Rod Side Flange Style

Bore size (mm)	A		B		FD	FT	FV	FX	FZ	L	
	5 st	10 st	5 st	10 st						5 st	10 st
12	55.9	65.9	37.4	42.4	4.5	5.5	25	45	55	18.5	23.5
16	54	64	35.5	40.5	4.5	5.5	30	45	55	18.5	23.5
20	56	66	36.5	41.5	6.6	8	39	48	60	19.5	24.5
25	57.5	67.5	37.5	42.5	6.6	8	42	52	64	20	25

Bore size (mm)	CQ2 L ₁		NCQ2 L ₁	
	5 st	10 st	5 st	10 st
12	29	34	26.5	31.5
16	30.5	35.5	26.5	31.5
20	33.5	38.5	27.5	32.5
25	37.5	42.5	29.5	34.5

Flange bracket material: Carbon steel

Head Side Flange Style

Bore size (mm)	A		L		CQ2 L ₁		NCQ2 L ₁	
	5 st	10 st	5 st	10 st	5 st	10 st	5 st	10 st
12	51.4	61.4	8.5	13.5	19	24	16.5	21.5
16	49.5	59.5	8.5	13.5	20.5	25.5	16.5	21.5
20	54	64	9.5	14.5	23.5	28.5	17.5	22.5
25	55.5	65.5	10	15	27.5	32.5	19.5	24.5

Flange bracket material: Carbon steel

(* Dimensions except A, L and L₁ are the same as rod side flange style.)

Double Clevis Style

Bore size (mm)	A		B		CB	CQ2 CD	NCQ2 CD inch	CL		CT	CU	CW
	5 st	10 st	5 st	10 st				5 st	10 st			
12	65.9	75.9	37.4	42.4	12	5	3/16	59.9	69.9	4	7	14
16	65	75	35.5	40.5	14	5	3/16	59	69	4	10	15
20	73	83	36.5	41.5	20	8	5/16	64	74	5	12	18
25	77.5	87.5	37.5	42.5	24	10	3/8	67.5	77.5	5	14	20

Bore size (mm)	CX	CZ	L		CQ2 L ₁		NCQ2 L ₁		CQ2 N	NCQ2 N inch	RR
			5 st	10 st	5 st	10 st	5 st	10 st			
12	5	10	8.5	13.5	19	24	16.5	21.5	M4 x 0.7	#8-32UNC	6
16	6.5	12	8.5	13.5	20.5	25.5	16.5	21.5	M4 x 0.7	#8-23UNC	6
20	8	16	9.5	14.5	23.5	28.5	17.5	22.5	M6 x 1.0	1/4-20UNC	9
25	10	20	10	15	27.5	32.5	19.5	24.5	M6 x 1.0	1/4-20UNC	10

Double clevis bracket material: Carbon steel
Surface treatment: Nickel plated

* For details about the rod end nut and accessory brackets, refer to page 178.
* Double clevis pin and retaining rings are included.

Standard

Single Acting

Double Rod

Axial Piping

Water Resistant

High Lateral Load

End Lock

Clean Series

Copper/Fluorine free series

Construction and Parts

Warranty and Operating Instructions

Mounting and Auto Switches

Made to Order

ø32 to ø50 Spring Extend - With Auto Switch

(Without auto switches, only the A, B, P and Q dimensions will be changed. Refer to the dimension table.)

Both ends tapped: (N)CQ2A/(N)CDQ2A

Standard (Through-hole): (N)CQ2B/(N)CDQ2B

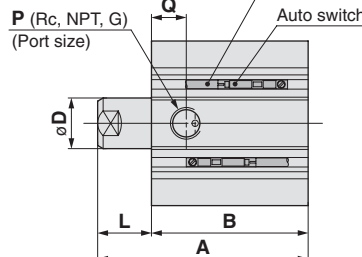
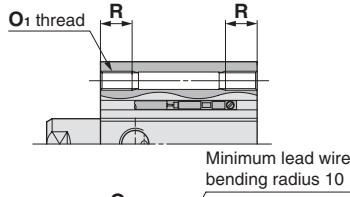
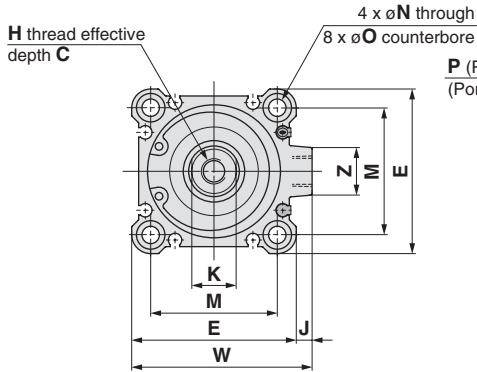

With boss on head end

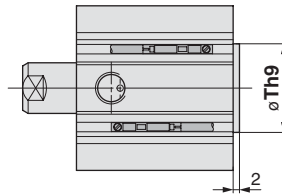

Rod end male thread

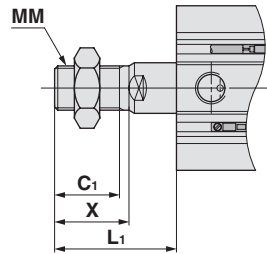

Built-in one-touch fittings: ø32 to ø50

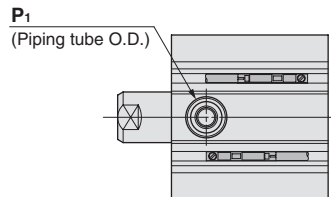
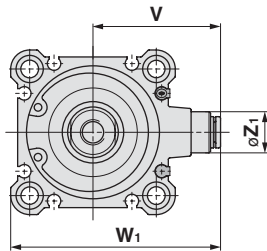

Both Ends Tapped Style

Bore size (mm)	CQ2 O1	NCQ2 O1 inch	R
32	M6 x 1.0	1/4-20UNC	10
40	M6 x 1.0	1/4-20UNC	10
50	M8 x 1.25	5/16-18UNC	14

With Boss in Head Side (CQ2 only)

Bore size (mm)	Th9
32	21 ⁰ _{-0.052}
40	28 ⁰ _{-0.052}
50	35 ⁰ _{-0.062}

Note) With boss in rod side is also available. (Suffix "-XC36" to the end of model number.)

CQ2 Rod End Male Thread

Bore size (mm)	C1	X	MM	L1		
				5 st	10 st	20 st
32	20.5	23.5	M14 x 1.5	33.5	38.5	—
40	20.5	23.5	M14 x 1.5	33.5	38.5	—
50	26	28.5	M18 x 1.5	—	43.5	53.5

NCQ2 Rod End Male Thread

Bore size (mm)	X	MM	L1		
			5 st	10 st	20 st
32	12.7	5/16-24UNF	24.7	29.7	—
40	16	3/8-24UNF	28	33	—
50	19.5	1/2-20UNF	—	37.5	47.5

"C1" dim. not applicable

Built-in One-touch Fittings (CQ2 only)

Bore size (mm)	Z1	P1	V	W1
32	13	6	36.5	59
40	13	6	40.5	66.5
50	16	8	50	82

Basic Style For auto switch proper mounting position and its mounting height, refer to pages 188 to 194.

Bore size (mm)	Without auto switch												With auto switch											
	A			B			CQ2 P			NCQ2 P			Q			A			B			CQ2 P	NCQ2 P	Q
	5 st	10 st	20 st	5 st	10 st	20 st	5 st	10 st	20 st	5 st	10 st	20 st	5 st	10 st	20 st	5 st	10 st	20 st	5 st	10 st	20 st			
32	40	50	—	28	33	—	M5 x 0.8	Rc 1/8	—	M5 x 0.8	NPT 1/8	—	11.5	10.5	—	50	60	—	38	43	—	Rc 1/8	NPT 1/8	10.5
40	46.5	56.5	—	34.5	39.5	—	Rc 1/8	—	—	NPT 1/8	—	—	11	11	—	56.5	66.5	—	44.5	49.5	—	Rc 1/8	NPT 1/8	11
50	—	68.5	78.5	—	40.5	50.5	—	Rc 1/4	—	—	NPT 1/4	—	10.5	10.5	—	68.5	88.5	—	50.5	60.5	—	Rc 1/4	NPT 1/4	10.5

Bore size (mm)	CQ2 C	NCQ2 C	D	E	CQ2 H	NCQ2 H inch	I	J	K	L			M	N	O	S	U	Z
										5 st	10 st	20 st						
32	13	13.3	16	45	M8 x 1.25	5/16-24UNF	60	4.5	14	12	17	—	34	5.5	9 depth 7	58.5	31.5	14
40	13	18.3	16	52	M8 x 1.25	3/8-24UNF	69	5	14	12	17	—	40	5.5	9 depth 7	66	35	14
50	15	17.5	20	64	M10 x 1.5	1/2-20UNF	86	7	17	—	18	28	50	6.6	11 depth 8	80	41	19

* For details about the rod end nut and accessory brackets, refer to page 178.

Foot: (N)CQ2L/(N)CDQ2L

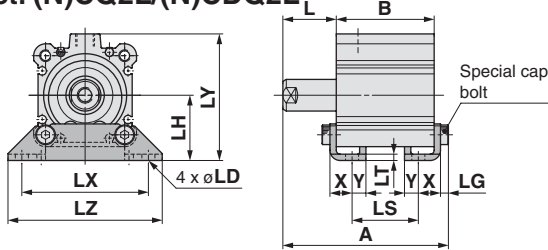

Rod end male thread

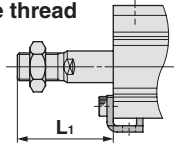

Rod flange: (N)CQ2F/(N)CDQ2F

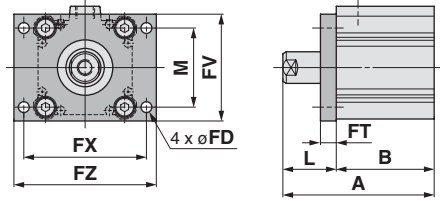

Rod end male thread

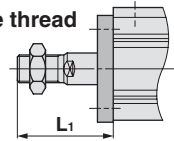

Head flange: (N)CQ2G/(N)CDQ2G

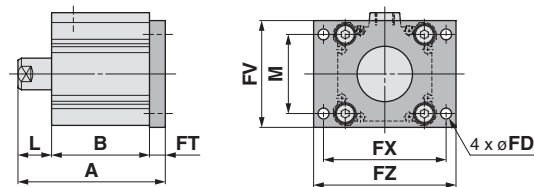

Rod end male thread

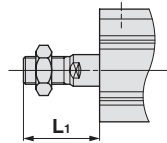

Double clevis: (N)CQ2D/(N)CDQ2D

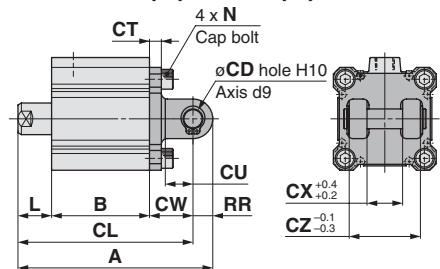

Rod end male thread

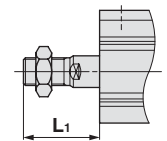

Foot Style

Bore size (mm)	Without auto switch						With auto switch											
	A		B		LS		A		B		LS							
	5 st	10 st	20 st	5 st	10 st	20 st	5 st	10 st	20 st	5 st	10 st	20 st						
32	57.2	67.2	—	28	33	—	12	17	—	67.2	77.2	—	38	43	—	22	27	—
40	63.7	73.7	—	34.5	39.5	—	18.5	23.5	—	73.7	83.7	—	44.5	49.5	—	28.5	33.5	—
50	—	76.7	96.7	—	40.5	50.5	—	17.5	27.5	—	86.7	106.7	—	50.5	60.5	—	27.5	37.5

Bore size (mm)	L		CQ2 L1			NCQ2 L1			LD	LG	LH	LX	LY	LZ	X	Y	
	5 st	10 st	20 st	5 st	10 st	20 st	5 st	10 st									20 st
	32	22	27	—	43.5	48.5	—	34.7									39.7
40	22	27	—	43.5	48.5	—	38	43	—	6.6	4	33	64	64	78	11.2	7
50	—	28	38	—	53.5	63.5	—	47.5	57.5	9	5	39	79	78	95	14.7	8

Foot bracket material: Carbon steel

Rod Side Flange Style

Bore size (mm)	Without auto switch						With auto switch																
	A		B		FD		A		B		FD		FT		FV		FX		FZ				
	5 st	10 st	20 st	5 st	10 st	20 st	5 st	10 st	20 st	5 st	10 st	20 st	5 st	10 st	20 st	5 st	10 st	20 st	5 st	10 st	20 st		
32	50	60	—	28	33	—	60	70	—	38	43	—	5.5	8	—	45	56	—	65	—	—	—	
40	56.5	66.5	—	34.5	39.5	—	66.5	76.5	—	44.5	49.5	—	5.5	8	—	54	62	—	72	—	—	—	
50	—	68.5	88.5	—	40.5	50.5	—	78.5	98.5	—	50.5	60.5	—	6.6	9	—	67	76	—	89	—	—	—

Bore size (mm)	L		CQ2 L1			NCQ2 L1			M	
	5 st	10 st	20 st	5 st	10 st	20 st	5 st	10 st		20 st
	32	22	27	—	43.5	48.5	—	34.7		39.7
40	22	27	—	43.5	48.5	—	38	43	—	40
50	—	28	38	—	53.5	63.5	—	47.5	57.5	50

Flange bracket material: Carbon steel

Head Side Flange Style

Bore size (mm)	Without auto switch						With auto switch								
	A		B		L		A		B		L				
	5 st	10 st	20 st	5 st	10 st	20 st	5 st	10 st	20 st	5 st	10 st	20 st			
32	48	58	—	58	68	—	12	17	—	33.5	38.5	—	24.7	29.7	—
40	45.5	64.5	—	64.5	74.5	—	12	17	—	33.5	38.5	—	28	33	—
50	—	67.5	87.5	—	77.5	97.5	—	18	28	—	43.5	53.5	—	37.5	47.5

Flange bracket material: Carbon steel

(* Dimensions except A, L and L1 are the same as rod side flange style.)

Double Clevis Style

Bore size (mm)	Without auto switch						With auto switch											
	A		B		CL		A		B		CL							
	5 st	10 st	20 st	5 st	10 st	20 st	5 st	10 st	20 st	5 st	10 st	20 st						
32	70	80	—	28	33	—	60	70	—	80	90	—	38	43	—	70	80	—
40	78.5	88.5	—	34.5	39.5	—	68.5	78.5	—	88.5	98.5	—	44.5	49.5	—	78.5	88.5	—
50	—	100.5	120.5	—	40.5	50.5	—	86.5	106.5	—	110.5	130.5	—	50.5	60.5	—	96.5	116.5

Bore size (mm)	CQ2 CD inch	NCQ2 CD inch	CT	CU	CW	CX	CZ	L		CQ2 L1			NCQ2 L1			
								5 st	10 st	20 st	5 st	10 st	20 st	5 st	10 st	20 st
								32	10	3/8	5	14	20	18	36	12
40	10	3/8	6	14	22	18	36	12	17	—	33.5	38.5	—	28	33	—
50	14	1/2	7	20	28	22	44	—	18	28	—	43.5	53.5	—	37.5	47.5

Double clevis bracket material: Cast iron
Surface treatment: Painted

Bore size (mm)	CQ2 N	NCQ2 N inch
32	M6 X 1.0	1/4-20UNC
40	M6 X 1.0	1/4-20UNC
50	M8 X 1.25	5/16-18UNC

* For details about the rod end nut and accessory brackets, refer to page 178.
* Double clevis pin and retaining rings are included.

Standard

Single Acting

Double Rod

Axial Piping

Water Resistant

High Lateral Load

End Lock

Clean Series

Copper/Fluorine free series

Construction and Parts

Warranty and Operating Instructions

Mounting and Auto Switches

Made to Order

How to Order

NC D Q2W B [] 25 - 30 D [] Z - []
C D Q2W B [] 32 [] - 30 D [] Z - []

Mounting threads

Nil	Metric
N	North American

Magnet

Nil	Without magnet
D	With magnet

Mounting

B	Through hole (std.)
A	Threaded
L	Foot
F	Rod flange

Type

Nil	Pneumatic
H	Air-hydro <small>Note 1)</small>

Note 1) Bore sizes available for air-hydro type are ø20 to ø100.

Bore size

12	12 mm
16	16 mm
20	20 mm
25	25 mm
32	32 mm
40	40 mm
50	50 mm
63	63 mm
80	80 mm
100	100 mm
125	125 mm
140	140 mm
160	160 mm
180	180 mm
200	200 mm

Note 7) Only CQ2 is available with ø180 and ø200 bores.

Port thread type

Nil	Rc
TN	NPT
TF	G
F	One Touch

Stroke standard (pneumatic)

Bore	Stroke standard (pneumatic)										Long stroke							
	5	10	15	20	25	30	35	40	45	50	75	100	125	150	175	200	250	300
12	●	●	●	●	●	●												
16	●	●	●	●	●	●												
20	●	●	●	●	●	●	●	●	●	●								
25	●	●	●	●	●	●	●	●	●	●								
32	●	●	●	●	●	●	●	●	●	●	●	●	●	●	●	●	●	●
40	●	●	●	●	●	●	●	●	●	●	●	●	●	●	●	●	●	●
50		●	●	●	●	●	●	●	●	●	●	●	●	●	●	●	●	●
63		●	●	●	●	●	●	●	●	●	●	●	●	●	●	●	●	●
80		●	●	●	●	●	●	●	●	●	●	●	●	●	●	●	●	●
100		●	●	●	●	●	●	●	●	●	●	●	●	●	●	●	●	●
125		●		●		●		●		●		●		●		●		●
140		●		●		●		●		●		●		●		●		●
160		●		●		●		●		●		●		●		●		●
180		●		●		●		●		●		●		●		●		●
200		●		●		●		●		●		●		●		●		●

● Standard normally stocked

Switch

M9	Solid state switch (see page 181 for details)
A9	Reed switch

New switch type (required if ordering "D")

Nil	No magnet, ø12 to 25
Z	ø12 to 200 with magnet, and ø32 to 200 w/o magnet

Body option

Nil	Standard (Rod end female thread)
F	With boss on head end
C	With bumper <small>Note 4)</small>
M	Rod end male thread

Combination of body options ("CM", "FC", "FM", "FCM") is available.
 Note 4) "DC" standard on ø125 and larger.

- Standard
- Single Acting
- Double Rod**
- Axial Piping
- Water Resistant
- High Lateral Load
- End Lock
- Clean Series
- Copper/Fluorine free series
- Construction and Parts
- Warranty and Operating Instructions
- Mounting and Auto Switches
- Made to Order

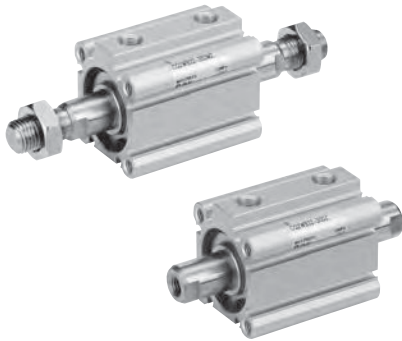

JIS Symbol

Double acting,
Double rod

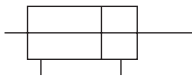

Specifications

Pneumatic type

Bore size (mm)	12	16	20	25	32	40	50	63	80	100	
Action	Double acting, Double rod										
Fluid	Air										
Proof pressure	218 psi (1.5 MPa)										
Maximum operating pressure	145 psi (1.0 MPa)										
Minimum operating pressure	10.2 psi (0.07 MPa)		7.3 psi (0.05 MPa)								
Ambient and fluid temperature	Without auto switch: -10 to 70°C (No freezing) With auto switch: -10 to 60°C (No freezing)										
Lubrication	Not required (Non-lube)										
Piston speed	50 to 500 mm/s										
Allowable kinetic energy (J)	Standard	0.022	0.038	0.055	0.09	0.15	0.26	0.46	0.77	1.36	2.27
	With rubber bumper	0.043	0.075	0.11	0.18	0.29	0.52	0.91	1.54	2.71	4.54
Stroke length tolerance	+1.0 mm (Note) 0										

Note) Stroke length tolerance does not include the amount of bumper change.

Air-hydro type

Bore size (mm)	20	25	32	40	50	63	80	100
Action	Double acting, Double rod							
Fluid	Turbine oil (Note)							
Proof pressure	218 psi (1.5 MPa)							
Maximum operating pressure	145 psi (1.0 MPa)							
Minimum operating pressure	26.1 psi (0.18 MPa)		14.5 psi (0.1 MPa)					
Ambient and fluid temperature	5 to 60°C							
Piston speed	5 to 50 mm/s							
Cushion	None							
Stroke length tolerance	+1.0 mm 0							

Note) Refer to "Handling Precautions for SMC Products" (M-E03-3) for Actuator Precautions (5).

Double Acting, Double Rod **Series (N)CQ2W**

Specifications - Large Bore

Specifications

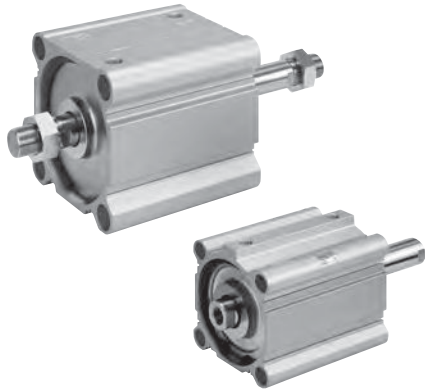

JIS Symbol
Double acting,
Double rod

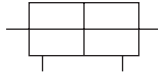

Bore size (mm)	125	140	160	180	200
Action	Double acting, Double rod				
Fluid	Air				
Proof pressure	218 psi (1.5 MPa)			152 psi (1.05 MPa)	
Maximum operating pressure	145 psi (1.0 MPa)			102 psi (0.7 MPa)	
Minimum operating pressure	0.05 MPa				
Ambient and fluid temperature	Without auto switch: -10 to 70°C (No freezing) With auto switch: -10 to 60°C (No freezing)				
Lubrication	Not required (Non-lube)				
Piston speed	50 to 500 mm/s			20 to 400 mm/s	
Allowable kinetic energy (J)	7.4	9.8	12.4		
Stroke length tolerance	+1.4 mm (Note) 0				

Note) Stroke length tolerance does not include the amount of bumper change.

Standard Strokes

Bore size (mm)	Standard stroke
125, 140, 160 180, 200	10, 20, 30, 40, 50, 75, 100, 125, 150, 175, 200, 250, 300

Manufacture of Intermediate Strokes

Type	A spacer is installed in the standard stroke body.		Exclusive body (-XB10)	
Part no.	Suffix "-X633" to the end of standard model number. (P. 49)		Suffix "-XB10" to the end of standard model number. (P. 49)	
Description	Strokes in 5 mm intervals are available by installing a spacer in the standard stroke cylinder.		Strokes in 1 mm intervals are available by using an exclusive body with the specified stroke.	
Stroke range	Bore size	Stroke range	Bore size	Stroke range
	125 to 160	5 to 295	125 to 160	11 to 299
Example	Part no.: CQ2WB160-165DCZ-X633 CQ2WB160-175DCZ with 10 mm width spacer inside The B dimension is 266 mm.		Part no.: CQ2WB160-165DCZ-XB10 Makes 165 mm stroke tube. The B dimension is 256 mm.	

Conversions

°F = 1.8°C + 32 1 J = 0.738 ft-lb
1 MPa = 145 psi 1 mm = 0.039 in

Standard

Single Acting

Double Rod

Axial Piping

Water Resistant

High Lateral Load

End Lock

Clean Series

Copper/Fluorine free series

Construction and Parts

Warranty and Operating Instructions

Mounting and Auto Switches

Made to Order

Allowable Lateral Load at Rod End

Without Auto Switch

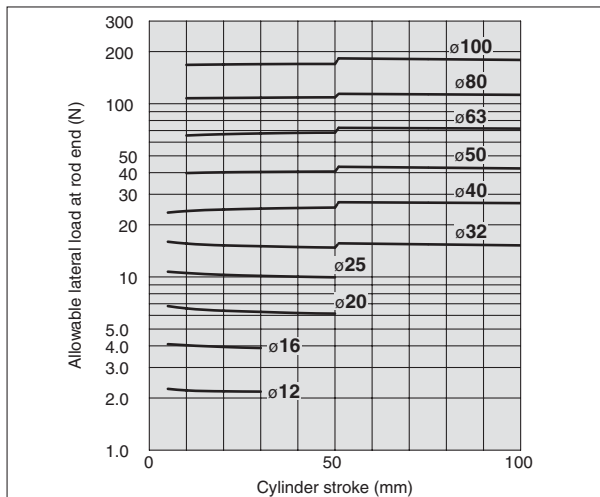

With Auto Switch

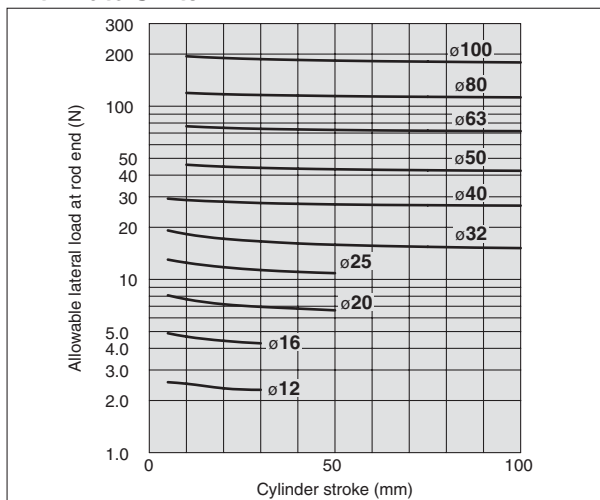

1 mm = 0.039 in
 1N = 0.2248 lbf

Theoretical Output

Bore size (mm)	Operating pressure (MPa)		
	0.3	0.5	0.7
12	25	42	59
16	45	75	106
20	71	118	165
25	113	189	264
32	181	302	422
40	317	528	739
50	495	825	1150
63	841	1400	1960
80	1360	2270	3170
100	2140	3570	5000

Weight

Bore size (mm)	Cylinder stroke (mm)											
	5	10	15	20	25	30	35	40	45	50	75	100
12	42	49	56	63	70	77	—	—	—	—	—	—
16	59	68	77	86	95	104	—	—	—	—	—	—
20	89	104	119	134	149	164	179	194	209	224	—	—
25	119	136	153	170	187	204	221	238	255	272	—	—
32	185	212	235	257	280	303	326	349	372	395	555	670
40	279	308	337	367	396	426	455	484	514	543	749	896
50	—	497	538	580	622	664	705	747	789	830	1122	1331
63	—	646	682	718	754	790	826	862	899	935	1187	1368
80	—	1149	1225	1302	1378	1455	1531	1608	1684	1760	2296	2678
100	—	1960	2068	2177	2286	2394	2503	2612	2720	2829	3589	4132

Additional Weight

Bore size (mm)	12	16	20	25	32	40	50	63	80	100	
Both ends tapped	2	2	6	6	6	6	6	19	45	45	
Rod end male thread	Male thread	3	6	12	24	52	54	106	106	240	350
	Nut	2	4	8	16	34	34	64	64	98	232
With rubber bumper	0	0	-2	-2	-3	-7	-12	-20	-34	-57	
Built-in one-touch fittings	—	—	—	—	12	12	21	21	—	—	
Foot (Including mounting bolts)	57	71	170	195	158	170	267	342	722	1107	
Flange (Including mounting bolts)	57	69	139	161	180	214	373	559	1056	1365	

Calculation: (Example) **CQ2WF32-20DCMZ**

- Basic weight: CQ2WB32-20DZ 257 g
 - Additional weight: Both ends tapped 6 g
 - Rod end male thread 86 g
 - With rubber bumper -3 g
 - Flange 180 g
- 526 g



Refer to the below pages for further information on auto switches.

Auto switch proper mounting position and its mounting height	P.188 to 194
Minimum stroke for auto switch mounting	
Operating range	
Auto switch mounting brackets/Part no.	

Weight

Bore size (mm)	Cylinder stroke (mm)											
	5	10	15	20	25	30	35	40	45	50	75	100
12	50	58	65	73	80	87	—	—	—	—	—	—
16	77	87	96	106	115	125	—	—	—	—	—	—
20	120	136	151	166	182	197	212	228	243	258	—	—
25	170	185	201	216	232	247	263	279	294	310	—	—
32	238	260	283	306	329	352	375	398	421	444	558	673
40	353	383	412	442	471	500	530	559	589	618	765	912
50	—	609	645	681	716	752	788	823	859	895	1073	1252
63	—	798	840	882	924	966	1008	1051	1093	1135	1346	1556
80	—	1393	1469	1546	1622	1699	1775	1851	1928	2004	2387	2769
100	—	2334	2443	2551	2660	2769	2877	2986	3094	3203	3746	4289

Additional Weight

Bore size (mm)	12	16	20	25	32	40	50	63	80	100	
Both ends tapped	1	1	3	3	6	6	6	19	45	45	
Rod end male thread	Male thread	3	6	12	24	52	54	106	106	240	350
	Nut	2	4	8	16	34	34	64	64	98	232
With rubber bumper	0	0	-2	-2	-3	-7	-12	-19	-34	-54	
Built-in one-touch fittings	—	—	—	—	12	12	21	21	—	—	
Foot (Incl. mounting bolts)	52	65	153	177	158	170	267	342	722	1107	
Flange (Incl. mounting bolts)	54	67	131	153	180	214	373	559	1056	1365	

Calculation: (Example) **CDQ2WF32-20DCMZ**

- Basic weight: CDQ2WB32-20DZ 306 g
 - Additional weight: Both ends tapped 6 g
 - Rod end male thread 86 g
 - With rubber bumper -3 g
 - Rod flange 180 g
- 575 g

Add each weight of auto switches when auto switches are mounted.

1g = 0.0353 oz
 1kg = 2.2046 lb
 1N = 0.2248 lbf

Standard

Single Acting

Double Rod

Axial Piping

Water Resistant

High Lateral Load

End Lock

Clean Series

Copper/Fluorine free series

Construction and Parts

Warranty and Operating Instructions

Mounting and Auto Switches

Made to Order

Theoretical Output

Bore size (mm)	Operating pressure (MPa)		
	0.3	0.5	0.7
125	3376	5627	7878
140	4313	7188	10063
160	5655	9425	13195
180	7257	12095	16933
200	9048	15080	21112

(N)

Weight

Without Auto Switch

(kg)

Bore size (mm)	Cylinder stroke (mm)												
	10	20	30	40	50	75	100	125	150	175	200	250	300
125	5.47	5.76	6.05	6.37	6.68	7.47	8.24	9.03	9.82	10.60	11.39	12.96	14.52
140	6.43	6.73	7.06	7.40	7.75	8.61	9.47	10.33	11.20	12.06	12.92	14.64	16.37
160	8.87	9.26	9.65	10.07	10.49	11.53	12.58	13.63	14.68	15.72	16.77	18.87	20.96
180	11.75	12.23	12.73	13.21	13.70	14.91	16.13	17.34	18.56	19.77	20.99	23.42	25.86
200	14.89	15.42	15.94	16.47	16.98	18.30	19.61	20.92	21.23	23.54	24.85	27.47	30.10

With Auto Switch

(kg)

Bore size (mm)	Cylinder stroke (mm)												
	10	20	30	40	50	75	100	125	150	175	200	250	300
125	5.53	5.82	6.11	6.43	6.74	7.53	8.30	9.09	9.88	10.66	11.45	13.02	14.58
140	6.50	6.80	7.13	7.47	7.82	8.68	9.54	10.40	11.27	12.13	12.99	14.71	16.44
160	8.95	9.34	9.73	10.15	10.57	11.61	12.66	13.71	14.76	15.80	16.85	18.95	21.04
180	11.83	12.31	12.81	13.29	13.78	14.99	16.21	17.42	18.64	19.85	21.07	23.50	25.94
200	14.97	15.50	16.02	16.55	17.06	18.38	19.69	21.00	21.31	23.62	24.93	27.55	30.18

Additional Weight

(kg)

Bore size (mm)		125	140	160, 180, 200
Rod end male thread	Male thread	0.62	0.62	0.96
	Nut	0.32	0.32	0.52

Calculation: (Example) **CDQ2WB125-30DCMZ**

- Basic weight: CDQ2WB125-30DCZ.....6.11 kg
 - Additional weight: Rod end male thread.....0.94 kg
- 7.05 kg

1g = 0.0353 oz
 1kg = 2.2046 lb
 1N = 0.2248 lbf

Series (N)CQ2W

Double Acting, Double Rod
Dimensions - Standard

ø12 to ø25 - Without Auto Switch

Both ends tapped: (N)CQ2WA

Both Ends Tapped Style

Bore size (mm)	CQ2 O ₁	NCQ2 O ₁ inch	R
12	M4 x 0.7	#8-32UNC	7
16	M4 x 0.7	#8-32UNC	7
20	M6 x 1.0	1/4-20UNC	10
25	M6 x 1.0	1/4-20UNC	10

Standard (Through-hole): (N)CQ2WB

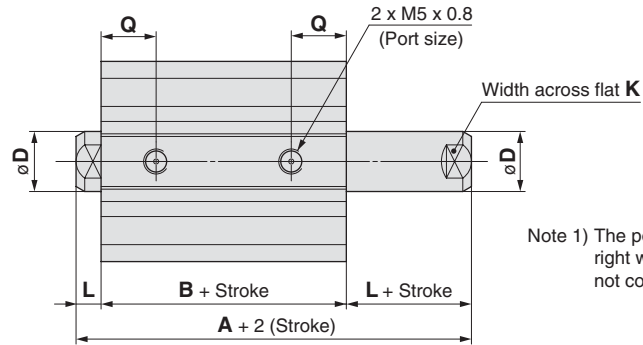
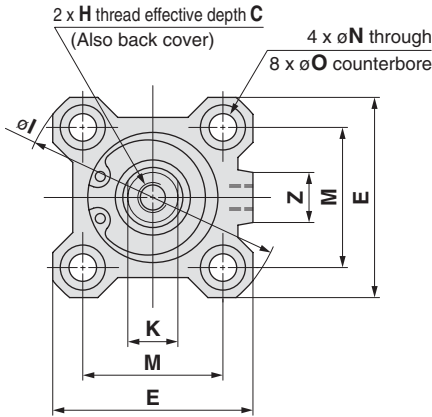
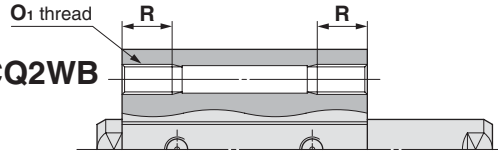

Note 1) The positions of left and right width across flats are not constant.

Rod end male thread

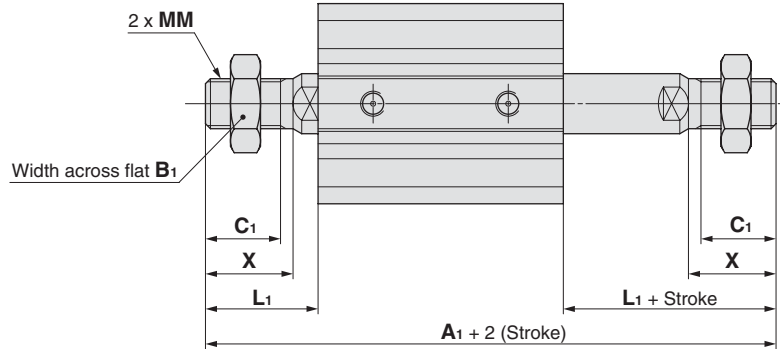

CQ2 Rod End Male Thread

Bore size (mm)	A ₁	C ₁	MM	L ₁	X
12	53.2	9	M5 x 0.8	14	10.5
16	57	10	M6 x 1.0	15.5	12
20	63	12	M8 x 1.25	18.5	14
25	74	15	M10 x 1.25	22.5	17.5

NCQ2 Rod End Male Thread

Bore size (mm)	A ₁	MM inch	L ₁	X
12	48.2	#8-32UNC	11.5	8
16	49	#8-32UNC	11.5	8
20	51	#10-32UNF	12.5	8
25	58	1/4-28UNF	14.5	9.5

C₁ dim. not applicable

Basic Style

Bore size (mm)	Stroke range (mm)	A	B	CQ2 C	NCQ2 C	D	E	CQ2 H	NCQ2 H inch	I	K	L	M	N	O	Q	Z
12	5 to 30	32.2	25.2	6	5.4	6	25	M3 x 0.5	#8-32UNC	32	5	3.5	15.5	3.5	6.5 depth 3.5	10	—
16	5 to 30	33	26	8	5.4	8	29	M4 x 0.7	#8-32UNC	38	6	3.5	20	3.5	6.5 depth 3.5	10	10
20	5 to 50	35	26	7	7	10	36	M5 x 0.8	#10-32UNF	47	8	4.5	25.5	5.5	9 depth 7	9.5	10
25	5 to 50	39	29	12	10	12	40	M6 x 1.0	1/4-28UNF	52	10	5	28	5.5	9 depth 7	11	10

Note 2) The external dimensions with rubber bumper are same as those of the standard, as shown above.

* For details about the rod end nut and accessory brackets, refer to page 178.

Foot: (N)CQ2WL

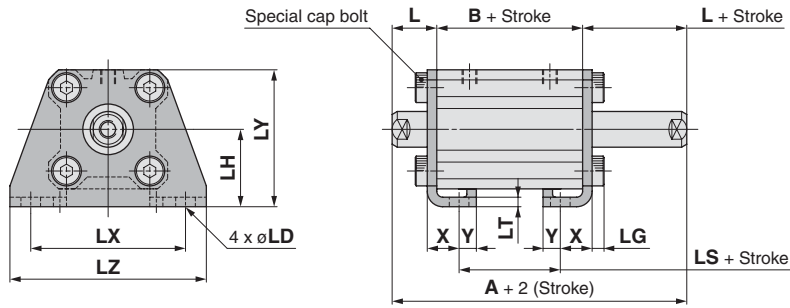

Rod end male thread

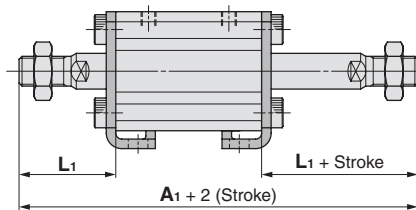

CQ2 Rod End, Male Thread

Bore size (mm)	A1	L1
12	73.2	24
16	77	25.5
20	83	28.5
25	94	32.5

NCQ2 Rod End, Male Thread

Bore size (mm)	A1	L1
12	68.2	21.5
16	69	21.5
20	71	22.5
25	78	24.5

Note) The positions of left and right width across flats are not constant.

Foot Style

Bore size (mm)	Stroke range (mm)	A	B	L	LD	LG	LH	LS	LT	LX	LY	LZ	X	Y
12	5 to 30	52.2	25.2	13.5	4.5	2.8	17	13.2	2	34	29.5	44	8	4.5
16	5 to 30	53	26	13.5	4.5	2.8	19	14	2	38	33.5	48	8	5
20	5 to 50	55	26	14.5	6.6	4	24	14	3.2	48	42	62	9.2	5.8
25	5 to 50	59	29	15	6.6	4	26	14	3.2	52	46	66	10.7	5.8

Foot bracket material: Carbon steel

Flange: (N)CQ2WF

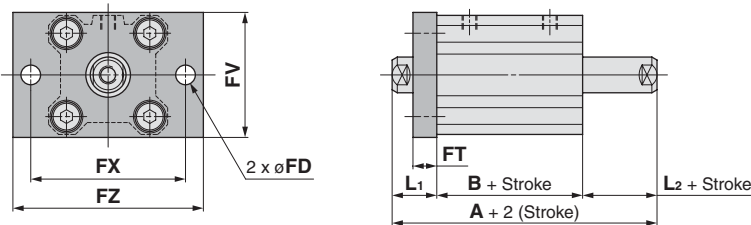

Rod end male thread

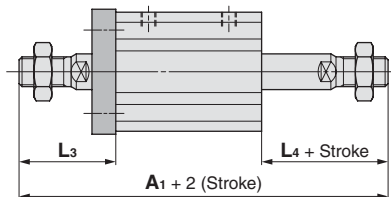

CQ2 Rod End, Male Thread

Bore size (mm)	A1	L3	L4
12	63.2	24	14
16	67	25.5	15.5
20	73	28.5	18.5
25	84	32.5	22.5

NCQ2 Rod End, Male Thread

Bore size (mm)	A1	L3	L4
12	52.8	21.5	11.5
16	59	21.5	11.5
20	61	22.5	12.5
25	68	24.5	14.5

Note) The positions of left and right width across flats are not constant.

Flange Style

Bore size (mm)	Stroke range (mm)	A	B	FD	FT	FV	FX	FZ	L1	L2
12	5 to 30	42.2	25.2	4.5	5.5	25	45	55	13.5	3.5
16	5 to 30	43	26	4.5	5.5	30	45	55	13.5	3.5
20	5 to 50	45	26	6.6	8	39	48	60	14.5	4.5
25	5 to 50	49	29	6.6	8	42	52	64	15	5

* For details about the rod end nut and accessory brackets, refer to page 178.

Flange bracket material: Carbon steel
Surface treatment: Nickel plated

- Standard
- Single Acting
- Double Rod**
- Axial Piping
- Water Resistant
- High Lateral Load
- End Lock
- Clean Series
- Copper/Fluorine free series
- Construction and Parts
- Warranty and Operating Instructions
- Mounting and Auto Switches
- Made to Order

Series (N)CQ2W Double Acting, Double Rod

Dimensions - Standard

ø12 to ø25 - With Auto Switch

Standard (Through-hole): (N)CDQ2WB

Both ends tapped: (N)CDQ2WA

Both Ends Tapped Style

Bore size (mm)	CQ2 O ₁	NCQ2 O ₁ inch	R
12	M4 x 0.7	#8-32UNC	7
16	M4 x 0.7	#8-32UNC	7
20	M6 x 1.0	1/4-20UNC	10
25	M6 x 1.0	1/4-20UNC	10

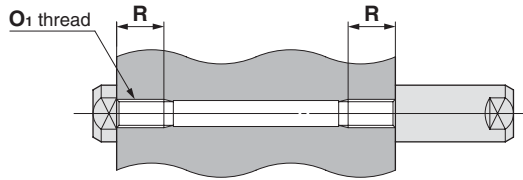

Note 1) The positions of left and right width across flats are not constant.

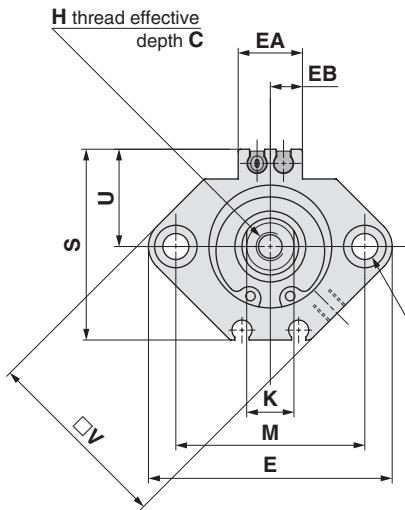

ø16 to ø25

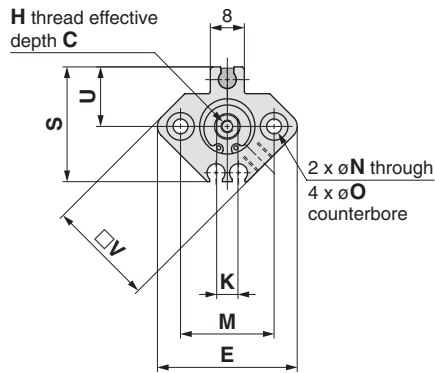
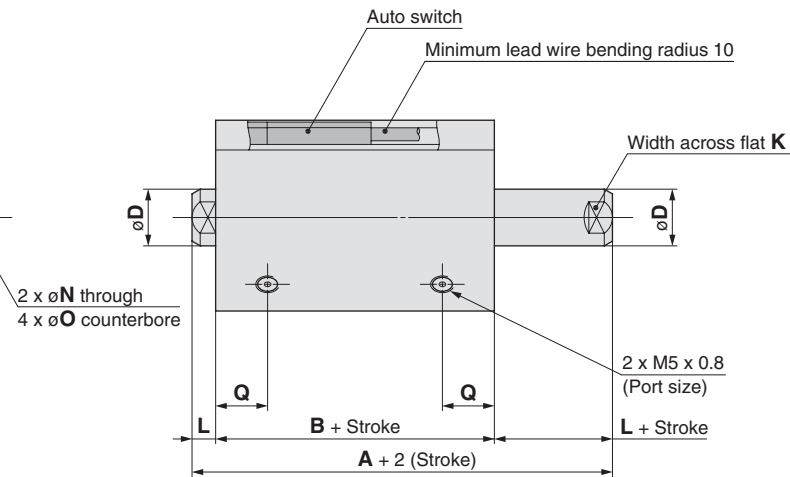

ø12

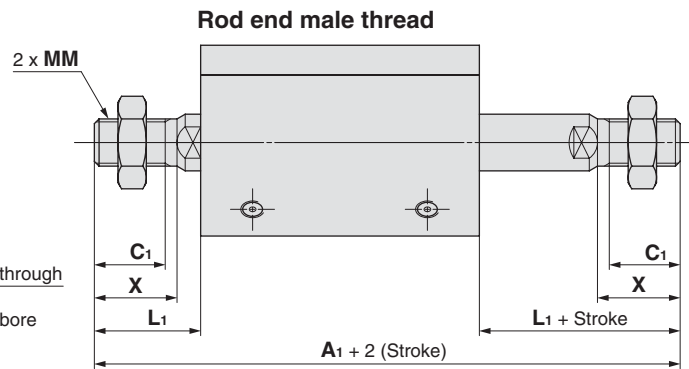

CQ2 Rod End Male Thread

Bore size (mm)	A ₁	C ₁	MM	L ₁	X
12	60.4	9	M5 x 0.8	14	10.5
16	67	10	M6 x 1.0	15.5	12
20	75	12	M8 x 1.25	18.5	14
25	84	15	M10 x 1.25	22.5	17.5

NCQ2 Rod End Male Thread

Bore size (mm)	A ₁	MM inch	L ₁	X
12	55.4	#8-32UNC	11.5	8
16	59	#8-32UNC	11.5	8
20	63	#10-32UNF	12.5	8
25	68	1/4-28UNF	14.5	9.5

C₁ dim. not applicable

Basic Style For auto switch proper mounting position and its mounting height, refer to pages 188 to 194.

Bore size (mm)	Stroke range (mm)	A	B	CQ2 C	NCQ2 C	D	E	CQ2 H	NCQ2 H inch	K	L	M	N	O	Q	S	U	V
12	5 to 30	39.4	32.4	6	5.4	6	32	M3 x 0.5	#8-32UNC	5	3.5	22	3.5	6.5 depth 3.5	10.5	35.5	19.5	25
16	5 to 30	43	36	8	5.4	8	38	M4 x 0.7	#8-32UNC	6	3.5	28	3.5	6.5 depth 3.5	10	41.5	22.5	29
20	5 to 50	47	38	7	7	10	47	M5 x 0.8	#10-32UNF	8	4.5	36	5.5	9 depth 7	10.5	48	24.5	36
25	5 to 50	49	39	12	10	12	52	M6 x 1.0	1/4-28UNF	10	5	40	5.5	9 depth 7	11	53.5	27.5	40

Note 2) The external dimensions with rubber bumper are same as those of the standard, as shown above.

* For details about the rod end nut and accessory brackets, refer to page 178.

Foot: (N)CDQ2WL

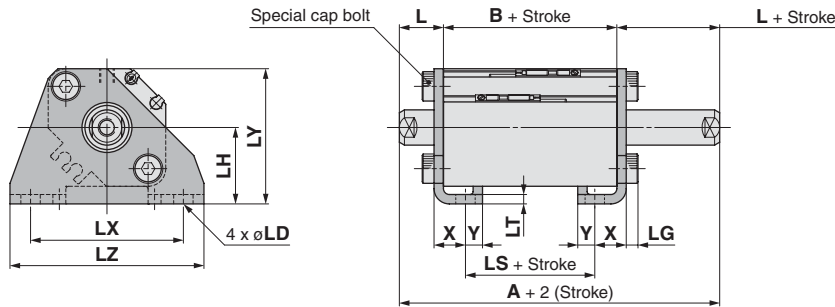

Note) The positions of left and right width across flats are not constant.

Rod end male thread

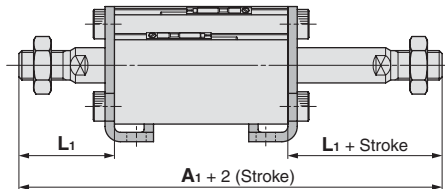

CQ2 Rod End, Male Thread

Bore size (mm)	A1	L1
12	80.4	24
16	87	25.5
20	95	28.5
25	104	32.5

Foot Style

Bore size (mm)	Stroke range (mm)	A	B	L	LD	LG	LH	LS	LT	LX	LY	LZ	X	Y
12	5 to 30	59.4	32.4	13.5	4.5	2.8	17	20.4	2	34	29.5	44	8	4.5
16	5 to 30	63	36	13.5	4.5	2.8	19	24	2	38	33.5	48	8	5
20	5 to 50	67	38	14.5	6.6	4	24	26	3.2	48	42	62	9.2	5.8
25	5 to 50	69	39	15	6.6	4	26	24	3.2	52	46	66	10.7	5.8

Foot bracket material: Carbon steel
Surface treatment: Nickel plated

NCQ2 Rod End, Male Thread

Bore size (mm)	A1	L1
12	75.4	21.5
16	79	21.5
20	83	22.5
25	88	24.5

Flange: (N)CDQ2WF

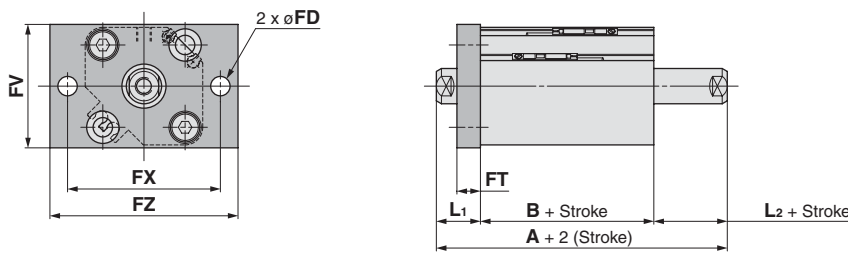

Note) The positions of left and right width across flats are not constant.

Rod end male thread

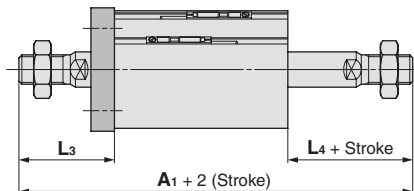

CQ2 Rod End, Male Thread

Bore size (mm)	A1	L3	L4
12	70.4	24	14
16	77	25.5	15.5
20	85	28.5	18.5
25	94	32.5	22.5

Flange Style

Bore size (mm)	Stroke range (mm)	A	B	FD	FT	FV	FX	FZ	L1	L2
12	5 to 30	49.4	32.4	4.5	5.5	25	45	55	13.5	3.5
16	5 to 30	53	36	4.5	5.5	30	45	55	13.5	3.5
20	5 to 50	57	38	6.6	8	39	48	60	14.5	4.5
25	5 to 50	59	39	6.6	8	42	52	64	15	5

* For details about the rod end nut and accessory brackets, refer to page 178.

Flange bracket material: Carbon steel
Surface treatment: Nickel plated

NCQ2 Rod End, Male Thread

Bore size (mm)	A1	L3	L4
12	65.4	21.5	11.5
16	69	21.5	11.5
20	73	22.5	12.5
25	78	24.5	14.5

Standard

Single Acting

Double Rod

Axial Piping

Water Resistant

High Lateral Load

End Lock

Clean Series

Copper/Fluorine free series

Construction and Parts

Warranty and Operating Instructions

Mounting and Auto Switches

Made to Order

Series (N)CQ2W Double Acting, Double Rod

Dimensions - Standard

ø32 to ø50 - With Auto Switch

(Without auto switches, only the A, B and P dimensions will be changed. Refer to the dimension table.)

Standard (Through-hole): (N)CQ2WB/(N)CDQ2WB

Both ends tapped: (N)CQ2WA/(N)CDQ2WA

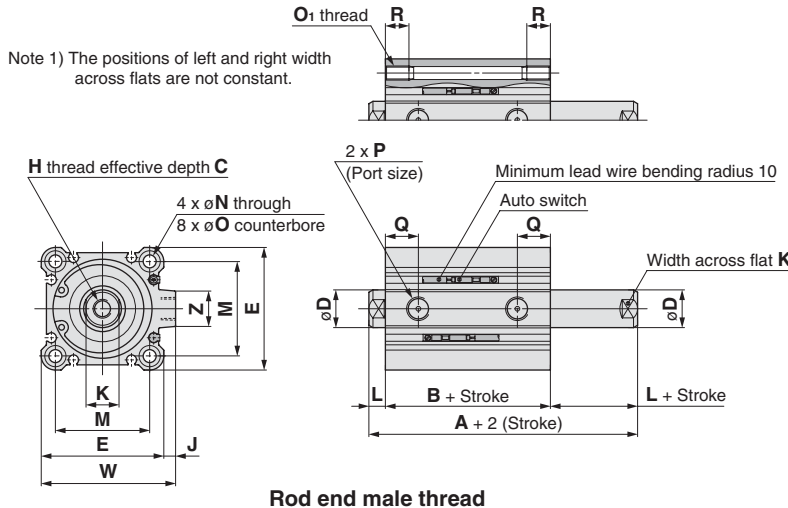

Both Ends Tapped Style

Bore size (mm)	CQ2 O ₁	NCQ2 O ₁ inch	R
32	M6 x 1.0	1/4-20UNC	10
40	M6 x 1.0	1/4-20UNC	10
50	M8 x 1.25	5/16-18UNC	14

CQ2W Rod End Male Thread

Bore size (mm)	Without auto switch			With auto switch		
	A1			A1		
	50 st or less	55 to 75	80 to 100	50 st or less	55 to 75	80 to 100
32	87.5 + Stroke	172.5	197.5	97.5 + Stroke	172.5	197.5
40	97 + Stroke	182	207	107 + Stroke	182	207
50	107.5 + Stroke	192.5	217.5	117.5 + Stroke	192.5	217.5

Bore size (mm)	C ₁	MM	L ₁	X
32	20.5	M14 x 1.5	28.5	23.5
40	20.5	M14 x 1.5	28.5	23.5
50	26	M18 x 1.5	33.5	28.5

NCQ2W Rod End Male Thread

Bore size (mm)	Without auto switch			With auto switch		
	A1			A1		
	50 st or less	55 to 75	80 to 100	50 st or less	55 to 75	80 to 100
32	69.9 + Stroke	154.9	179.9	79.9 + Stroke	154.9	179.9
40	86 + Stroke	171	196	96 + Stroke	171	196
50	95.5 + Stroke	180.5	205.5	105.5 + Stroke	180.5	205.5

Bore size (mm)	MM inch	L ₁	X
32	5/16-24UNF	19.7	12.7
40	3/8-24UNF	23	16
50	1/2-20UNF	27.5	19.5

C₁ dim. not applicable

Built-in One-touch Fittings (CQ2 only)

Bore size (mm)	Without auto switch		With auto switch		Z ₁	P ₁
	V	W ₁	V	W ₁		
32	38	60.5	36.5	59	13	6
40	42	68	40.5	66.5	13	6
50	50	82	50	82	16	8

Built-in one-touch fittings: ø32 to ø50

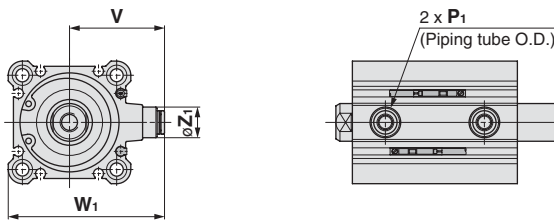

Basic Style For auto switch proper mounting position and its mounting height, refer to pages 188 to 194.

Bore size (mm)	Without auto switch										With auto switch							
	A			B			P (CQ2)		P (NCQ2)		A		B		P (CQ2)		P (NCQ2)	
	50 st or less	55 to 75	80 to 100	50 st or less	55 to 75	80 to 100	5 st	10 to 100	5 st	10 to 100	50 st or less	55 to 75	80 to 100	50 st or less	55 to 75	80 to 100	5 to 100 st	5 to 100 st
32	44.5 + Stroke	129.5	154.5	30.5 + Stroke	115.5	140.5	M5 x 0.8	Rc 1/8	M5 x 0.8	NPT 1/8	54.5 + Stroke	129.5	154.5	40.5 + Stroke	115.5	140.5	Rc 1/8	NPT 1/8
40	54 + Stroke	139	164	40 + Stroke	125	150	Rc 1/8	Rc 1/8	NPT 1/8	NPT 1/8	64 + Stroke	139	164	50 + Stroke	125	150	Rc 1/8	NPT 1/8
50	56.5 + Stroke	141.5	166.5	40.5 + Stroke	125.5	150.5	Rc 1/4	Rc 1/4	NPT 1/4	NPT 1/4	66.5 + Stroke	141.5	166.5	50.5 + Stroke	125.5	150.5	Rc 1/4	NPT 1/4

Bore size (mm)	CQ2 C	NCQ2 C	D	E	CQ2 H	NCQ2 H inch	I	J	K	L	M	N	O	Q	S	U	Z
32	13	13.3	16	45	M8 x 1.25	5/16-24UNF	60	4.5	14	7	34	5.5	9 depth 7	12.5	58.5	31.5	14
40	13	18.3	16	52	M8 x 1.25	3/8-24UNF	69	5	14	7	40	5.5	9 depth 7	14	66	35	14
50	15	17.6	20	64	M10 x 1.5	1/2-20UNF	86	7	17	8	50	6.6	11 depth 8	14	80	41	19

Note) External dimensions with rubber bumper are same as standard type as shown above.

* For details about the rod end nut and accessory brackets, refer to page 178.

Note) When obtaining the full length dimension of 50 stroke or less, it requires to add the stroke twice.

Example) Full length dimension

$$= A + \text{Stroke}$$

$$= (\text{⊙} + \text{Stroke}) + \text{Stroke}$$

Foot: (N)CQ2WL/(N)CDQ2WL

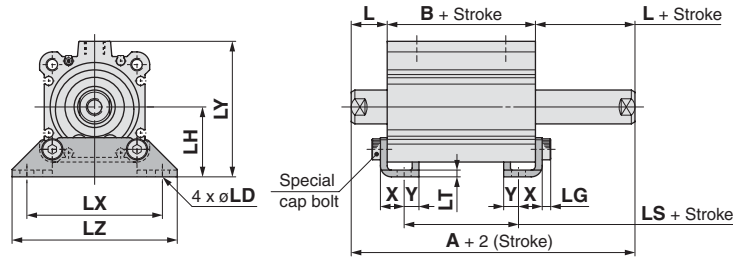

Rod end male thread

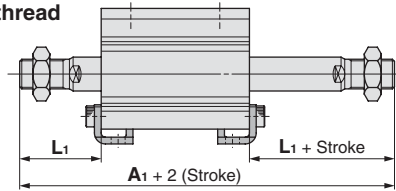

Note) The positions of left and right width across flats are not constant.

CQ2W Rod End Male Thread

Bore size (mm)	Without auto switch			With auto switch			L1
	A1			A1			
	50 st or less	55 to 75	80 to 100	50 st or less	55 to 75	80 to 100	
32	107.5 + st	192.5	217.5	117.5 + st	192.5	217.5	38.5
40	117 + st	202	227	127 + st	202	227	38.5
50	127.5 + st	212.5	237.5	137.5 + st	212.5	237.5	43.5

NCQ2W Rod End Male Thread

Bore size (mm)	Without auto switch			With auto switch			L1
	A1			A1			
	50 st or less	55 to 75	80 to 100	50 st or less	55 to 75	80 to 100	
32	89.9 + st	174.9	199.9	99.9 + st	174.9	199.9	29.7
40	106 + st	191	216	116 + st	191	216	33
50	115.5 + st	200.5	225.5	125.5 + st	200.5	225.5	37.5

Foot Style

Bore size (mm)	Stroke range (mm)	Without auto switch									With auto switch								
		A			B			LS			A			B			LS		
		50 st or less	55 to 75	80 to 100	50 st or less	55 to 75	80 to 100	50 st or less	55 to 75	80 to 100	50 st or less	55 to 75	80 to 100	50 st or less	55 to 75	80 to 100	50 st or less	55 to 75	80 to 100
32	5 to 50, 75, 100	64.5 + st	149.5	174.5	30.5 + st	115.5	140.5	14.5 + st	99.5	124.5	74.5 + st	149.5	174.5	40.5 + st	115.5	140.5	24.5 + st	99.5	124.5
40	5 to 50, 75, 100	74 + st	159	184	40 + st	125	150	24 + st	109	134	84 + st	159	184	50 + st	125	150	34 + st	109	134
50	10 to 50, 75, 100	76.5 + st	161.5	186.5	40.5 + st	125.5	150.5	17.5 + st	102.5	127.5	86.5 + st	161.5	186.5	50.5 + st	125.5	150.5	27.5 + st	102.5	127.5

Foot bracket material: Carbon steel

Bore size (mm)	L	LD	LG	LH	LT	LX	LY	LZ	X	Y
32	17	6.6	4	30	3.2	57	57	71	11.2	5.8
40	17	6.6	4	33	3.2	64	64	78	11.2	7
50	18	9	5	39	3.2	79	78	95	14.7	8

Flange: (N)CQ2WF/(N)CDQ2WF

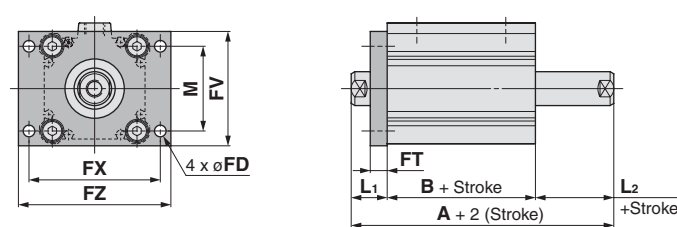

Rod end male thread

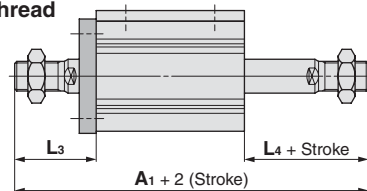

CQ2W Rod End Male Thread

Bore size (mm)	Without auto switch			With auto switch			L3	L4
	A1			A1				
	50 st or less	55 to 75	80 to 100	50 st or less	55 to 75	80 to 100		
32	97.5 + st	182.5	207.5	107.5 + st	182.5	207.5	38.5	28.5
40	107 + st	192	217	117 + st	192	217	38.5	28.5
50	117.5 + st	202.5	227.5	127.5 + st	202.5	227.5	43.5	33.5

NCQ2W Rod End Male Thread

Bore size (mm)	Without auto switch			With auto switch			L3	L4
	A1			A1				
	50 st or less	55 to 75	80 to 100	50 st or less	55 to 75	80 to 100		
32	79.9 + st	164.9	189.9	89.9 + st	164.9	189.9	29.7	19.7
40	96 + st	181	206	106 + st	181	206	33	23
50	105.5 + st	190.5	215.5	115.5 + st	190.5	215.5	37.5	27.5

Note) The positions of left and right width across flats are not constant.

Flange Style

Bore size (mm)	Stroke range (mm)	Without auto switch									With auto switch										
		A			B			A			B			FD	FT	FV	FX	FZ	L1	L2	M
		50 st or less	55 to 75	80 to 100	50 st or less	55 to 75	80 to 100	50 st or less	55 to 75	80 to 100	50 st or less	55 to 75	80 to 100								
32	5 to 50, 75, 100	54.5 + st	139.5	164.5	30.5 + st	115.5	140.5	64.5 + st	139.5	164.5	40.5 + st	115.5	140.5	5.5	8	48	56	65	17	7	34
40	5 to 50, 75, 100	64 + st	149	174	40 + st	125	150	74 + st	149	174	50 + st	125	150	5.5	8	54	62	72	17	7	40
50	10 to 50, 75, 100	66.5 + st	151.5	176.5	40.5 + st	125.5	150.5	76.5 + st	151.5	176.5	50.5 + st	125.5	150.5	6.6	9	67	76	89	18	8	50

Note) When obtaining the full length dimension of 50 stroke or less, it requires to add the stroke twice.
Example) Full length dimension = A + Stroke = (○+ Stroke) + Stroke

Flange bracket material: Carbon steel

Standard

Single Acting

Double Rod

Axial Piping

Water Resistant

High Lateral Load

End Lock

Clean Series

Copper/Fluorine free series

Construction and Parts

Warranty and Operating Instructions

Mounting and Auto Switches

Made to Order

Series (N)CQ2W Double Acting, Double Rod

Dimensions - Standard

ø63 to ø100 - With Auto Switch

(Without auto switches, only the A and B dimensions will be changed. Refer to the dimension table.)

Both ends tapped: (N)CQ2WA/(N)CDQ2WA

Standard (Through-hole): (N)CQ2WB/(N)CDQ2WB

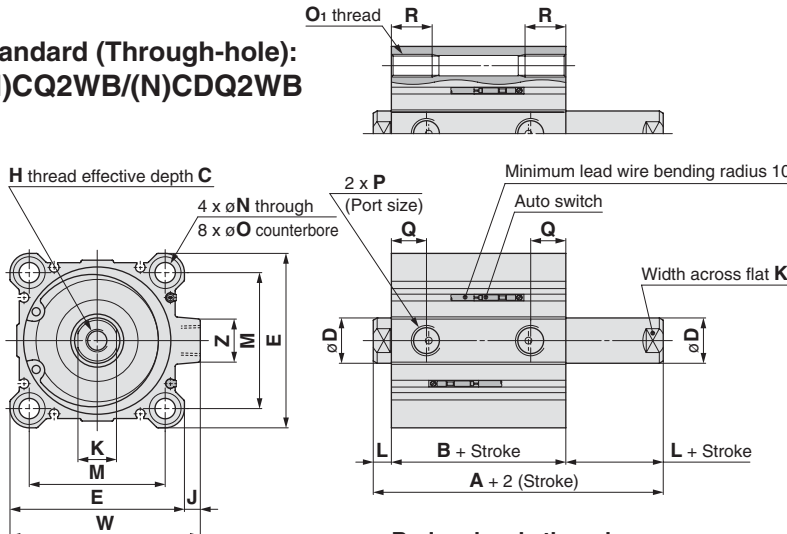

Rod end male thread

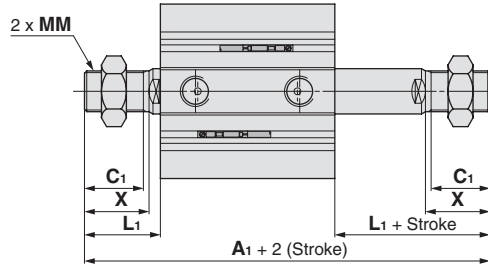

Both Ends Tapped Style

Bore size (mm)	CQ2 O1	NCQ2 O1 inch	R
63	M10 x 1.5	7/16-14UNC	18
80	M12 x 1.75	1/2-13UNC	22
100	M12 x 1.75	1/2-13UNC	22

Note 1) The positions of left and right width across flats are not constant.

CQ2W Rod End Male Thread

Bore size (mm)	Without auto switch			With auto switch		
	A1			A1		
	50 st or less	55 to 75	80 to 100	50 st or less	55 to 75	80 to 100
63	109 + st	194	219	119 + st	194	219
80	138 + st	223	248	148 + st	223	248
100	147.5 + st	232.5	257.5	157.5 + st	232.5	257.5

Bore size (mm)	C1	MM	L1	X
63	26	M18 x 1.5	33.5	28.5
80	32.5	M22 x 1.5	43.5	35.5
100	32.5	M26 x 1.5	43.5	35.5

NCQ2W Rod End Male Thread

Bore size (mm)	Without auto switch			With auto switch		
	A1			A1		
	50 st or less	55 to 75	80 to 100	50 st or less	55 to 75	80 to 100
63	97 + st	182	207	107 + st	182	207
80	122 + st	207	232	132 + st	207	232
100	141.5 + st	226.5	251.5	151.5 + st	226.5	251.5

Bore size (mm)	MM inch	L1	X
63	1/2-20UNF	27.5	19.5
80	5/8-18UNF	35.5	25.5
100	3/4-16UNF	40.5	28.5

C1 dim. not applicable

Built-in One-touch Fittings (CQ2 only)

Bore size (mm)	Z1	P1	V	W1
63	16	8	56.5	95

* In the case of built-in One-touch fitting, the 5 mm stroke with ø32 bore is the same external dimensions as 10 mm stroke.

Built-in one-touch fittings

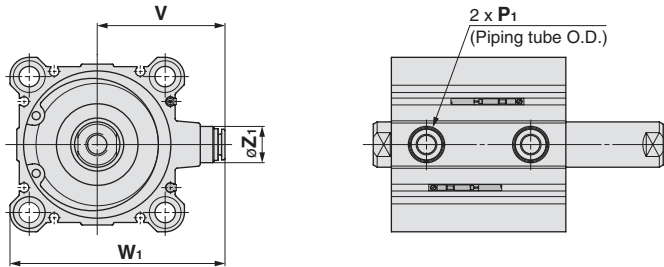

Basic Style For auto switch proper mounting position and its mounting height, refer to pages 188 to 194.

Bore size (mm)	Stroke range (mm)	Without auto switch						With auto switch					
		A			B			A			B		
		50 st or less	55 to 75	80 to 100	50 st or less	55 to 75	80 to 100	50 st or less	55 to 75	80 to 100	50 st or less	55 to 75	80 to 100
63	10 to 50, 75, 100	58 + st	143	168	42 + st	127	152	68 + st	143	168	52 + st	127	152
80	10 to 50, 75, 100	71 + st	156	181	51 + st	136	161	81 + st	156	181	61 + st	136	161
100	10 to 50, 75, 100	84.5 + st	169.5	194.5	60.5 + st	145.5	170.5	94.5 + st	169.5	194.5	70.5 + st	145.5	170.5

Bore size (mm)	CQ2 C	NCQ2 C	D	E	CQ2 H	NCQ2 H inch	I	J	K	L	M	N	O	CQ2 P	NCQ2 P inch	Q	S	U	Z
63	15	17.6	20	77	M10 x 1.5	1/2-20UNF	103	7	17	8	60	9	14 depth 10.5	Rc 1/4	NPT 1/4	15.5	93	47.5	19
80	21	24.3	25	98	M16 x 2.0	5/8-18UNF	132	6	22	10	77	11	17.5 depth 13.5	Rc 3/8	NPT 3/8	18	112.5	57.5	26
100	27	27	30	117	M20 x 2.5	3/4-16UNF	156	6.5	27	12	94	11	17.5 depth 13.5	Rc 3/8	NPT 3/8	22	132.5	67.5	26

Note) External dimensions with rubber bumper are same as standard type as shown above.

* For details about the rod end nut and accessory brackets, refer to page 178.

Note) When obtaining the full length dimension of 50 stroke or less, add the stroke twice.

Example) Full length dimension = A + Stroke = (○ ○ + Stroke) + Stroke

Foot: (N)CQ2WL/(N)CDQ2WL

Note) The positions of left and right width across flats are not constant.

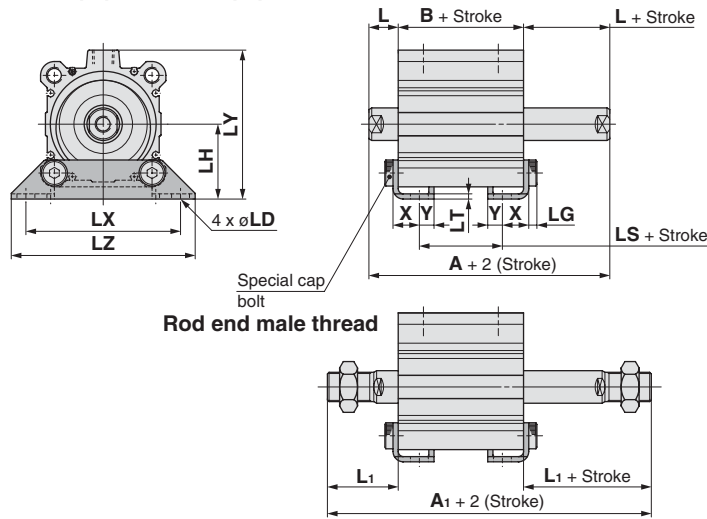

CQ2W Rod End Male Thread

Bore size (mm)	Without auto switch			With auto switch			L1
	A1			A1			
	50 st or less	55 to 75	80 to 100	50 st or less	55 to 75	80 to 100	
63	129 + st	214	239	139 + st	214	239	43.5
80	158 + st	243	268	168 + st	243	268	53.5
100	167.5 + st	252.5	277.5	177.5 + st	252.5	277.5	53.5

NCQ2W Rod End Male Thread

Bore size (mm)	Without auto switch			With auto switch			L1
	A1			A1			
	50 st or less	55 to 75	80 to 100	50 st or less	55 to 75	80 to 100	
63	117 + st	202	227	127 + st	202	227	37.5
80	142 + st	227	252	152 + st	227	252	45.5
100	161.5 + st	246.5	271.5	171.5 + st	246.5	271.5	50.5

Foot Style

Bore size (mm)	Stroke range (mm)	Without auto switch									With auto switch								
		A			B			LS			A			B			LS		
		50 st or less	55 to 75	80 to 100	50 st or less	55 to 75	80 to 100	50 st or less	55 to 75	80 to 100	50 st or less	55 to 75	80 to 100	50 st or less	55 to 75	80 to 100	50 st or less	55 to 75	80 to 100
63	5 to 50,75,100	78 + st	163	188	42 + st	127	152	16 + st	101	126	88 + st	163	188	52 + st	127	152	26 + st	101	126
80	5 to 50,75,100	91 + st	176	201	51 + st	136	161	21 + st	106	131	101 + st	176	201	61 + st	136	161	31 + st	106	131
100	10 to 50,75,100	104.5 + st	189.5	214.5	60.5 + st	145.5	170.5	26.5 + st	111.5	136.5	114.5 + st	189.5	214.5	70.5 + st	145.5	170.5	36.5 + st	111.5	136.5

Bore size (mm)	L	LD	LG	LH	LT	LX	LY	LZ	X	Y
63	18	11	5	46	3.2	95	91.5	113	16.2	9
80	20	13	7	59	4.5	118	114	140	19.5	11
100	22	13	7	71	6	137	136	162	23	12.5

Foot bracket material: Carbon steel

Flange: (N)CQ2WF/(N)CDQ2WF

Note) The positions of left and right width across flats are not constant.

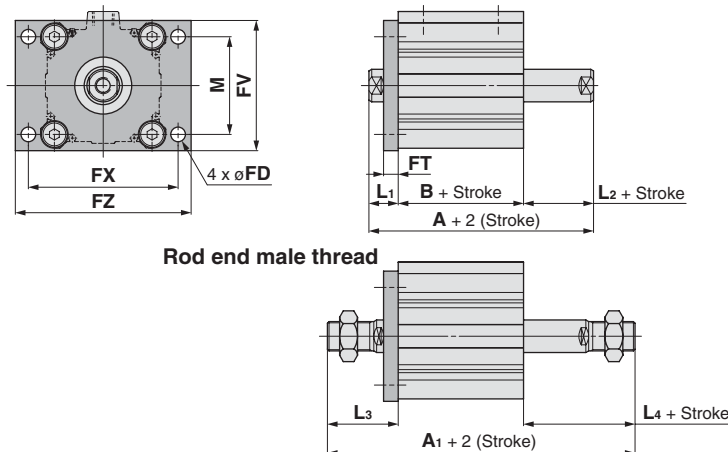

CQ2 Rod End Male Thread

Bore size (mm)	Without auto switch			With auto switch			L3	L4
	A1			A1				
	50 st or less	55 to 75	80 to 100	50 st or less	55 to 75	80 to 100		
63	119 + st	204	229	129 + st	204	229	43.5	33.5
80	148 + st	233	258	158 + st	233	258	53.5	43.5
100	157.5 + st	242.5	267.5	167.5 + st	242.5	267.5	53.5	43.5

NCQ2 Rod End Male Thread

Bore size (mm)	Without auto switch			With auto switch			L3	L4
	A1			A1				
	50 st or less	55 to 75	80 to 100	50 st or less	55 to 75	80 to 100		
63	107 + st	192	217	117 + st	192	217	37.5	27.5
80	132 + st	217	242	142 + st	217	242	45.5	35.5
100	151.5 + st	236.5	261.5	161.5 + st	236.5	261.5	50.5	40.5

Basic Style For auto switch proper mounting position and its mounting height, refer to pages 188 to 194.

Bore size (mm)	Stroke range (mm)	Without auto switch						With auto switch						FD	FT	FV	FX	FZ	L1	L2	M
		A		B		LS		A		B		LS									
		50 st or less	55 to 75	80 to 100	50 st or less	55 to 75	80 to 100	50 st or less	55 to 75	80 to 100	50 st or less	55 to 75	80 to 100								
63	10 to 50, 75, 100	68 + st	153	178	42 + st	127	152	78 + st	153	178	52 + st	127	152	9	9	80	92	108	18	8	60
80	10 to 50, 75, 100	81 + st	166	191	51 + st	136	161	91 + st	166	191	61 + st	136	161	11	11	99	116	134	20	10	77
100	10 to 50, 75, 100	94.5 + st	179.5	204.5	60.5 + st	145.5	170.5	104.5 + st	179.5	204.5	70.5 + st	145.5	170.5	11	11	117	136	154	22	12	94

Note) When obtaining the full length dimension of 50 stroke or less, it requires to add the stroke twice.
Example) Full length dimension = A + Stroke = (○) + Stroke + Stroke

Flange bracket material: Carbon steel

Standard

Single Acting

Double Rod

Axial Piping

Water Resistant

High Lateral Load

End Lock

Clean Series

Copper/Fluorine free series

Construction and Parts

Warranty and Operating Instructions

Mounting and Auto Switches

Made to Order

ø125 to ø160

Standard (Through-hole): (N)C□Q2WB

The dimensions are the same with or without an auto switch.

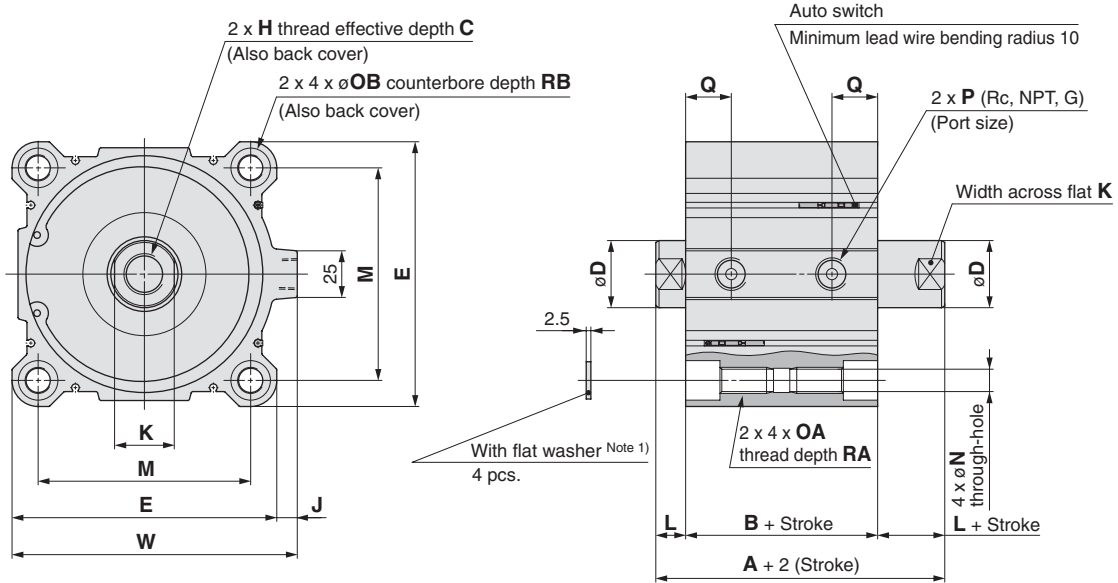

CQ2 Rod End Male Thread

Bore size (mm)	A1	C1	MM	L1	X
125	199	42	M30 x 1.5	58	45
140	199	42	M30 x 1.5	58	45
160	219	47	M36 x 1.5	64	50

NCQ2 Rod End Male Thread

Bore size (mm)	A1	C1	MM inch	L1	X
125	199	42	1-1/4-12UNF	58	45
140	199	42	1-1/4-12UNF	58	45
160	219	47	1-3/8-12UNF	64	50

Rod end male thread

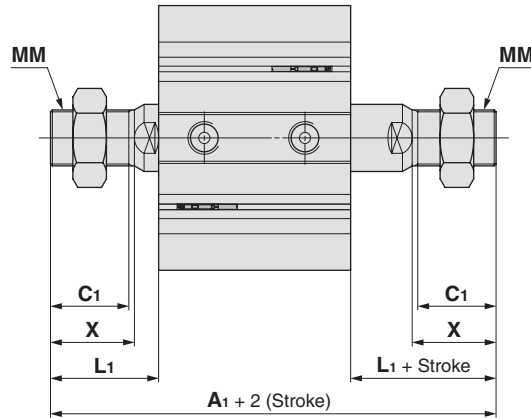

Switches in the above figure are the case for the reed switches D-A73 type and D-A80 type.

Bore size (mm)	Standard stroke range	A	B	C ⁽²⁾	D	E	CQ2 H	NCQ2 H inch	I	J	K	L	M	N	CQ2 OA	NCQ2 OA inch
125	10, 20, 30, 40, 50	115	83	30 (22.5)	36	142	M22 x 2.5	3/4-16UNF	190	11	32	16	114	12.5	M14 x 2	9/16-12UNC
140	75, 100, 125, 150	115	83	30 (22.5)	36	158	M22 x 2.5	3/4-16UNF	210	10	32	16	128	12.5	M14 x 2	9/16-12UNC
160	175, 200, 250, 300	125	91	33 (26.5)	40	178	M24 x 3	3/4-16UNF	238	10	36	17	144	14.5	M16 x 2	5/8-11UNC

Bore size (mm)	OB	CQ2 P	NCQ2 P	Q	RA	RB	S	U
125	21.2	Rc 3/8	NPT 3/8	24.5	25	18.4	162	80
140	21.2	Rc 3/8	NPT 3/8	24.5	25	18.4	177	88
160	24.2	Rc 3/8	NPT 3/8	27.5	28	21.2	197	98

Note 1) Be sure to use the attached plain washer for mounting, cylinder with through-holes.

Note 2) () denotes the values of effective length in one side, only for the 10 stroke type.

ø180, ø200

ø180

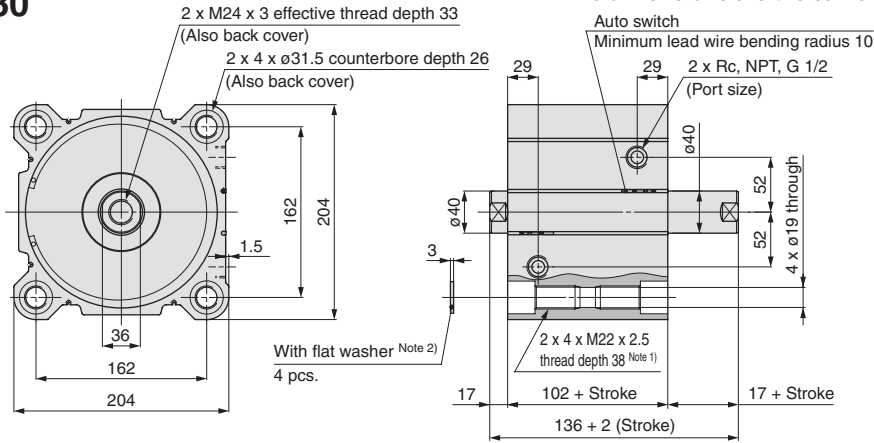

The dimensions are the same with or without an auto switch.

Note 1) In the case of 20 mm stroke or less, it would come with 2 x 4 x M22 x 2.5 through thread.
Note 2) Be sure to use the attached flat washer for mounting cylinder with through-holes.

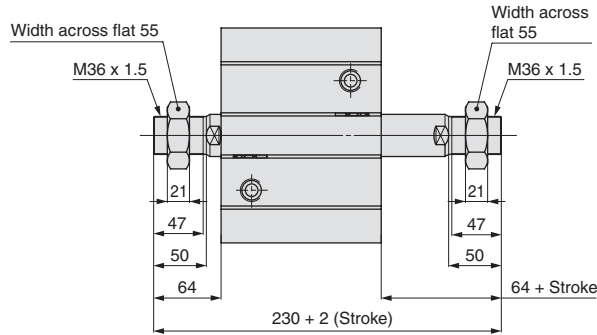

ø200

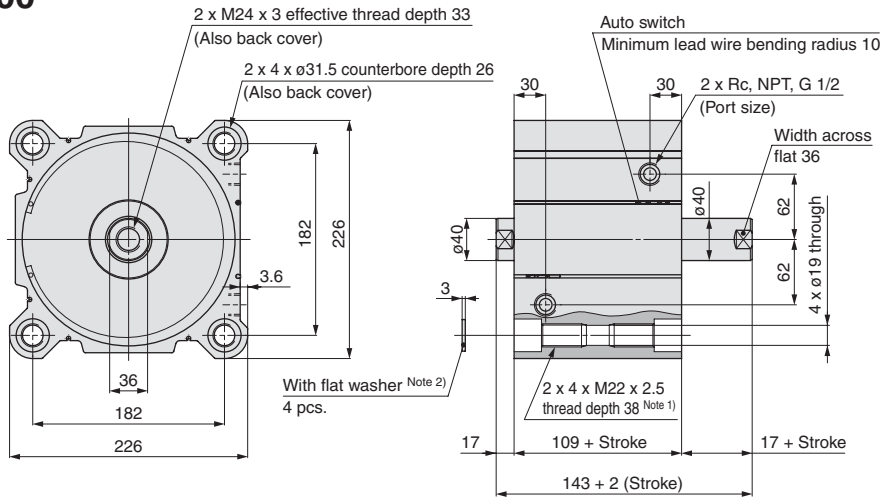

Note 1) In the case of 20 mm stroke or less, it would come with 2 x 4 x M22 x 2.5 through thread.
Note 2) Be sure to use the attached flat washer for mounting cylinder with through-holes.

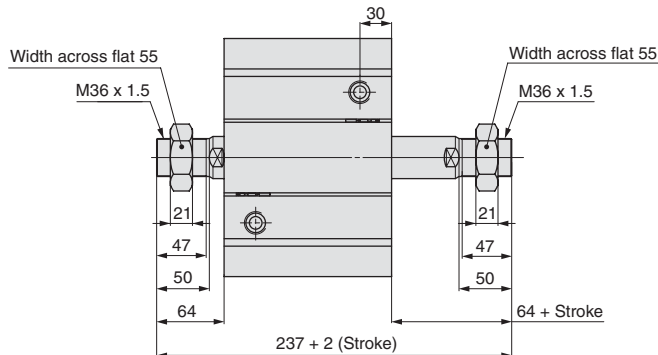

* The positions of double rod width across flats are not constant.

Standard
Single Acting
Double Rod
Axial Piping
Water Resistant
High Lateral Load
End Lock
Clean Series
Copper/Fluorine free series
Construction and Parts
Warranty and Operating Instructions
Mounting and Auto Switches
Made to Order

How to Order

NC D Q2KW B 25 - 30 D Z -

C D Q2KW B 32 - 30 D Z -

● **Mounting threads**

Nil	Metric
N	North American

● **Magnet**

Nil	Without magnet
D	With magnet

● **Mounting**

B	Through hole (std.)
A	Threaded
L	Foot
G	Head flange
F	Rod flange

● **Bore size**

12	12 mm
16	16 mm
20	20 mm
25	25 mm
32	32 mm
40	40 mm
50	50 mm
63	63 mm

● **Port thread type**

Nil	Rc
TN	NPT
TF	G
F	One Touch

● **Stroke standard (pneumatic)**

Bore	5	10	15	20	25	30	35	40	45	50	75	100
12	●	●	●	●	●	●						
16	●	●	●	●	●	●						
20	●	●	●	●	●	●	●	●	●	●		
25	●	●	●	●	●	●	●	●	●	●		
32	●	●	●	●	●	●	●	●	●	●	●	●
40	●	●	●	●	●	●	●	●	●	●	●	●
50		●	●	●	●	●	●	●	●	●	●	●
63		●	●	●	●	●	●	●	●	●	●	●

● Standard normally stocked
○ Manufactured option

● **Switch**

M9	Solid state switch (see page 181 for details)
A9	Reed switch

● **New switch type (required if ordering "D")**

Nil	No magnet, ø12 to 25
Z	ø12 to 63 with magnet, and ø32 to 63 w/o magnet

● **Body option**

Nil	Standard (Rod end female thread)
F	With boss on head end
C	With bumper ^{Note 4)}
M	Rod end male thread

Combination of body options ("CM", "FC", "FM", "FCM") is available.
Note 4) "DC" standard on ø125 and larger.

* Mounting brackets are shipped together, (but not assembled).
* Cylinder mounting bolts are not included. Order them separately referring to "Mounting Bolt for C(D)Q2B" on pages 156 and 157.

Built-in Magnet Cylinder Model

If a built-in magnet cylinder without an auto switch is required, there is no need to enter the symbol for the auto switch.
(Example) CDQ2KW B32-30DZ

- Standard
- Single Acting
- Double Rod**
- Axial Piping
- Water Resistant
- High Lateral Load
- End Lock
- Clean Series
- Copper/Fluorine free series
- Construction and Parts
- Warranty and Operating Instructions
- Mounting and Auto Switches
- Made to Order



Symbol
Non-rotating rod,
Double acting

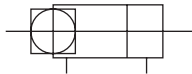

Specifications

Bore size (mm)	12	16	20	25	32	40	50	63
Action	Double acting, Double rod							
Fluid	Air							
Proof pressure	218 psi (1.5 MPa)							
Maximum operating pressure	145 psi (1.0 MPa)							
Minimum operating pressure	10.2 psi (0.07 MPa)		7.3 psi (0.05 MPa)					
Ambient and fluid temperature	Without auto switch: -10 to 70°C (No freezing) With auto switch: -10 to 60°C (No freezing)							
Lubrication	Not required (Non-lube)							
Piston speed	50 to 500 mm/s							
Allowable kinetic energy (J)	0.022 <small>Note 1</small> 0.043	0.038	0.055	0.09	0.15	0.26	0.46	0.77
Stroke length tolerance	+1.0 mm <small>Note 2</small> 0							
Rod non-rotating accuracy	±2°		±1°			±0.8°		

* ø12 with auto switch: With rubber bumper (Standard)

Note 1) For cylinders with rubber bumper (ø12 with auto switch only)

Note 2) Stroke length tolerance does not include the amount of bumper change.

Standard Strokes

Bore size	Standard stroke
12, 16	5, 10, 15, 20, 25, 30
20, 25	5, 10, 15, 20, 25, 30, 35, 40, 45, 50
32, 40	5, 10, 15, 20, 25, 30, 35, 40, 45, 50, 75, 100
50, 63	10, 15, 20, 25, 30, 35, 40, 45, 50, 75, 100

Manufacture of Intermediate Strokes

Type	A spacer is installed in the standard stroke body.	
Part no.	Refer to "How to Order" for the standard model number. (P. 67)	
Description	Strokes in 5 mm intervals are available by installing a spacer in the standard stroke cylinder.	
Stroke range	Bore size 32 to 63	Stroke range 55 to 95
Example	Part no.: CQ2KWB50-65DZ CQ2KWB50-75DZ with 10 mm width spacer inside The B dimension is 125.5 mm.	

Refer to pages 188 to 194 for the specifications of cylinders with autoswitches.

- Auto switch proper mounting position (detection at stroke end) and its mounting height
- Minimum stroke for auto switch mounting
- Operating range
- Auto switch mounting brackets/Part no.

Conversions

°F = 1.8°C + 32 1 J = 0.738 ft-lb
1 MPa = 145 psi 1 mm = 0.039 in

Technical Information - Non-Rotating Rod

Weight

Bore size (mm)	Cylinder stroke (mm)											
	5	10	15	20	25	30	35	40	45	50	75	100
12	62	69	76	83	90	97	—	—	—	—	—	—
16	62	73	84	95	106	117	—	—	—	—	—	—
20	101	116	131	146	161	176	191	206	221	236	—	—
25	138	155	172	189	206	223	240	257	274	291	—	—
32	233	256	279	302	325	348	371	394	417	440	600	715
40	336	365	394	424	453	483	512	541	571	600	806	953
50	—	517	558	600	642	684	725	767	809	850	1142	1351
63	—	742	779	815	851	887	923	959	995	1032	1285	1465

Additional Weight

Bore size (mm)		12	16	20	25	32	40	50	63
Both ends tapped		—	—	—	—	—	6	6	19
Rod end male thread	Male thread	3	6	12	24	52	54	106	106
	Nut	2	4	8	16	34	34	64	64
Built-in one-touch fittings		—	—	—	—	12	12	21	21
Foot		—	—	—	—	—	154	243	317
Flange		—	—	—	—	—	214	373	559

Calculation: (Example) **CQ2KWA40-20DMZ**

- Basic weight: CQ2KWB40-20DZ 424 g
- Additional weight: Both ends tapped 6 g
- Rod end male thread 88 g
- 518 g

Theoretical Output

Bore size (mm)	Operating pressure (MPa)		
	0.3	0.5	0.7
12	25	42	59
16	45	75	106
20	71	118	165
25	113	189	264
32	181	302	422
40	317	528	739
50	495	825	1150
63	841	1400	1960

- Standard
- Single Acting
- Double Rod**
- Axial Piping
- Water Resistant
- High Lateral Load
- End Lock
- Clean Series
- Copper/Fluorine free series
- Construction and Parts
- Warranty and Operating Instructions
- Mounting and Auto Switches
- Made to Order

Conversions

1 g = 0.0353 oz 1 mm = 0.039 in
 1 kg = 2.2046 lb 1N = 0.2248 lbf

ø12 to ø32 - Without Auto Switch

Standard (Through-hole): (N)CQ2KWB

ø12 to ø25

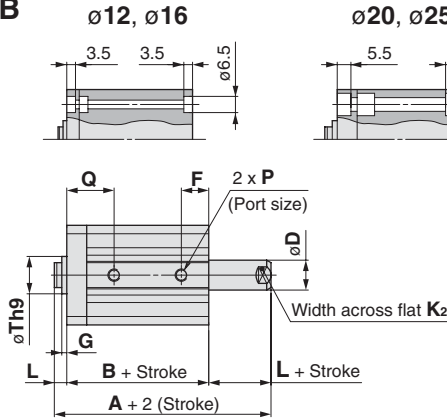
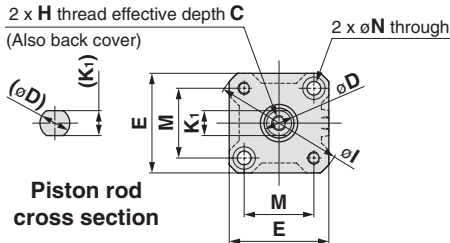

CQ2 Rod End Male Thread

Bore size (mm)	Stroke range (mm)	A ₁	C ₁	MM
12	5 to 30	58.2	9	M5 x 0.8
16	5 to 30	62	10	M6 x 1.0
20	5 to 50	71	12	M8 x 1.25
25	5 to 50	82	15	M10 x 1.25
32	5 to 50	96.5	20.5	M14 x 1.5
	75,100	106.5		

ø32

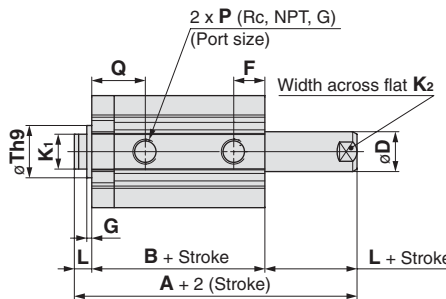
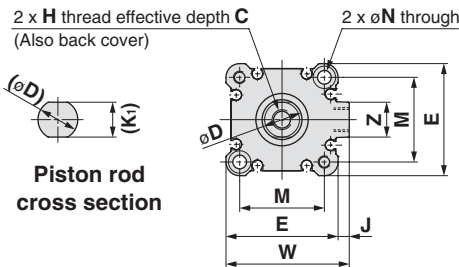

Bore size (mm)	L ₁	X
12	14	10.5
16	15.5	12
20	18.5	14
25	22.5	17.5
32	28.5	23.5

NCQ2 Rod End Male Thread

Bore size (mm)	Stroke range (mm)	A ₁	MM inch
12	5 to 30	53.2	#8-32UNC
16	5 to 30	54	#8-32UNC
20	5 to 50	59	#10-32UNF
25	5 to 50	66	1/4-28UNF
32	5 to 50	78.9	5/16-24UNF

Bore size (mm)	L ₁	X
12	11.5	8
16	11.5	8
20	12.5	8
25	14.5	9.5
32	19.7	12.7

*C₁" dim. not applicable

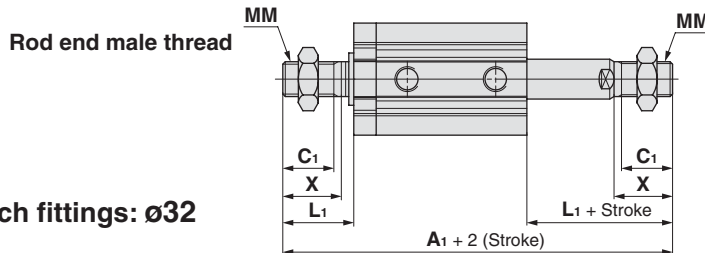

Built-in one-touch fittings: ø32

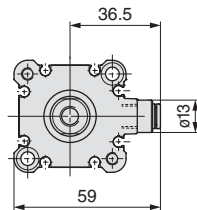

Built-in one-touch fittings

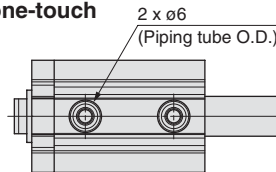

* The dimensions of ø32-5 mm stroke with built-in one-touch fittings are the same as those of the 10 mm stroke cylinder tube.

Standard

Bore size (mm)	Stroke range (mm)	A	B	CQ2 C	NCQ2 C	D	E	F	G	CQ2 H	NCQ2 H inch	I	J	K1	K2	L	M	N	CQ2 P	NCQ2 P	Q	Th9	W	Z
12	5 to 30	37.2	30.2	6	5.4	6	25	10	1.5	M3 x 0.5	#8-32UNC	32	—	5.2	5	3.5	15.5	3.5	M5 x 0.8	M5 x 0.8	15	15 ⁰ _{-0.043}	—	—
16	5 to 30	38	31	8	5.4	8	29	10	1.5	M4 x 0.7	#8-32UNC	38	—	6	6	3.5	20	3.5	M5 x 0.8	M5 x 0.8	15	20 ⁰ _{-0.052}	—	—
20	5 to 50	43	34	7	7	10	36	9.5	2	M5 x 0.8	#10-32UNF	47	—	8	8	4.5	25.5	5.5	M5 x 0.8	M5 x 0.8	17.5	13 ⁰ _{-0.043}	—	—
25	5 to 50	47	37	12	10	12	40	11	2	M6 x 1.0	1/4-28UNF	52	—	10	10	5	28	5.5	M5 x 0.8	M5 x 0.8	19	15 ⁰ _{-0.043}	—	—
32	5	53.5	39.5	13	13.3	16	45	12.5	2	M8 x 1.25	5/16-24UNF	60	4.5	14	14	7	34	5.5	M5 x 0.8	M5 x 0.8	21.5	21 ⁰ _{-0.052}	49.5	14
	10 to 50																		NPT 1/8					
	75, 100	63.5	49.5	—	—	—	—	—	—	—	—	—	—	—	—	—	—	—	—	—	—	—	—	—

* For details about the rod end nut and accessory brackets, refer to page 178.
Note) The positions of piston rod's width across flats (K₂) are not constant.

ø12 to ø32 - With Auto Switch

Standard (Through-hole): (N)CDQ2KWB

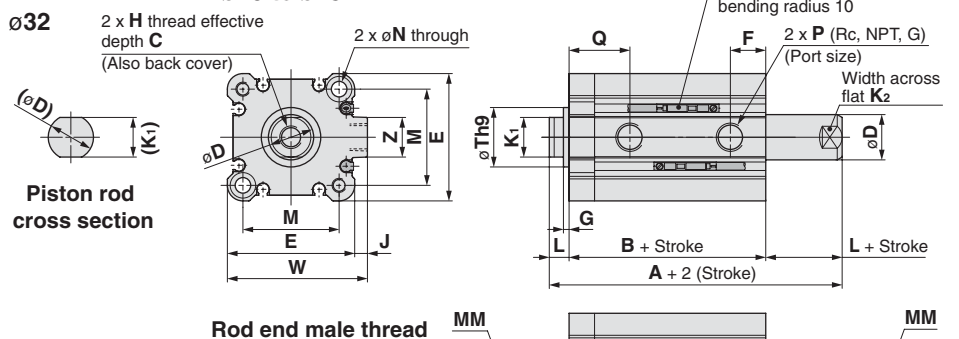
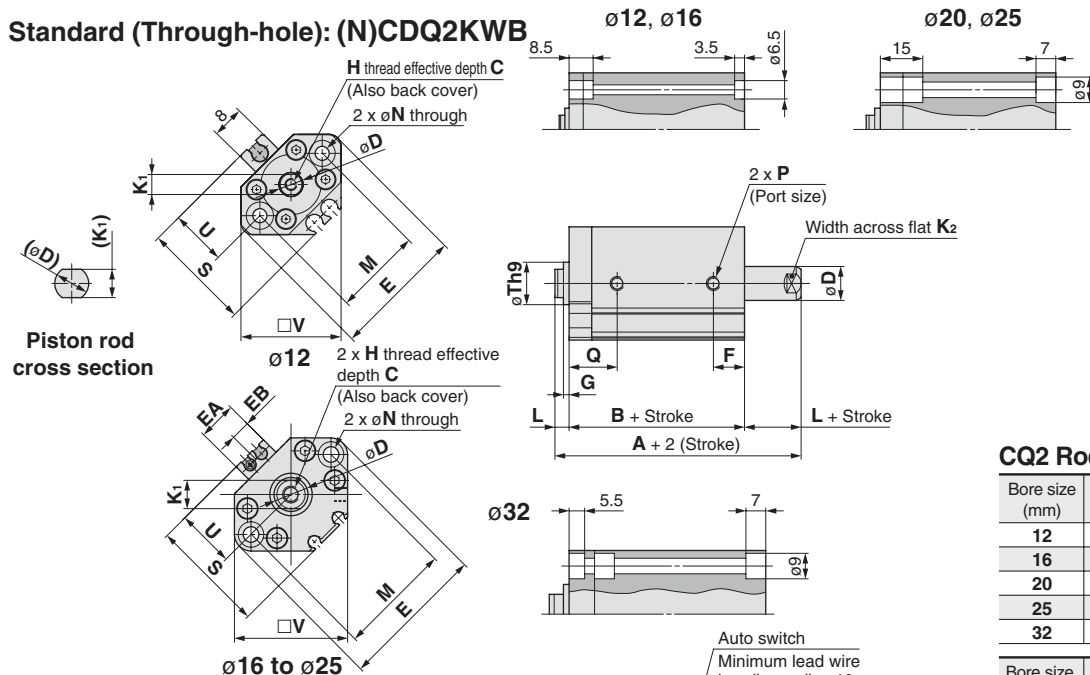

Built-in one-touch fittings: ø32

Standard For auto switch proper mounting position and its mounting height, refer to pages 188 to 194. (mm)

Bore size (mm)	Stroke range (mm)	A	B	CQ2 C	NCQ2 C	D	E	F	G	CQ2 H	NCQ2 H inch	I	J	K1	K2	L	M	N	CQ2 P	NCQ2 P	Q	S	Th9	U	V	Z
12	5 to 30	44.4	37.4	6	5.4	6	32	10.5	1.5	M3 x 0.5	#8-32UNC	—	—	5.2	5	3.5	22	3.5	M5 x 0.8	M5 x 0.8	15.5	35.5	15 ⁰ _{-0.043}	19.5	25	—
16	5 to 30	48	41	8	5.4	8	38	10	1.5	M4 x 0.7	#8-32UNC	—	—	6	6	3.5	28	3.5	M5 x 0.8	M5 x 0.8	15	41.5	20 ⁰ _{-0.052}	22.5	29	—
20	5 to 50	55	46	7	7	10	47	10.5	2	M5 x 0.8	#10-32UNF	—	—	8	8	4.5	36	5.5	M5 x 0.8	M5 x 0.8	18.5	48	13 ⁰ _{-0.043}	24.5	36	—
25	5 to 50	57	47	12	10	12	52	11	2	M6 x 1.0	1/4-28UNF	—	—	10	10	5	40	5.5	M5 x 0.8	M5 x 0.8	19	53.5	15 ⁰ _{-0.043}	27.5	40	—
32	5 to 50 <small>Note 11</small> 75, 100	63.5	49.5	13	13.3	16	45	12.5	2	M8 x 1.25	5/16-24UNF	60	4.5	14	14	7	34	5.5	Rc 1/8	NPT 1/8	21.5	58.5	21 ⁰ _{-0.052}	31.5	—	14

* For details about the rod end nut and accessory brackets, refer to page 178.

Note) The positions of piston rod's width across flats (K₂) are not constant.

CQ2 Rod End Male Thread

Bore size (mm)	A ₁	C ₁	MM
12	65.4	9	M5 x 0.8
16	72	10	M6 x 1.0
20	83	12	M8 x 1.25
25	92	15	M10 x 1.25
32	106.5	20.5	M14 x 1.5

Bore size (mm)	L ₁	X
12	14	10.5
16	15.5	12
20	18.5	14
25	22.5	17.5
32	28.5	23.5

NCQ2 Rod End Male Thread

Bore size (mm)	A ₁	MM inch
12	60.4	#8-32UNC
16	64	#8-32UNC
20	71	#10-32UNF
25	76	1/4-28UNF
32	88.9	5/16-24UNF

Bore size (mm)	L ₁	X
12	11.5	8
16	11.5	8
20	12.5	8
25	14.5	9.5
32	19.7	12.7

*C₁" dim. not applicable

- Standard
- Single Acting
- Double Rod
- Axial Piping
- Water Resistant
- High Lateral Load
- End Lock
- Clean Series
- Copper/Fluorine free series
- Construction and Parts
- Warranty and Operating Instructions
- Mounting and Auto Switches
- Made to Order

Series (N)CQ2KW

Double Acting, Double Rod
Dimensions - Non-Rotating Rod

ø40 to ø63 - With Auto Switch

(Without auto switches, only the A, B dimensions will be changed.
Refer to the dimension table.)

Both ends tapped: (N)CQ2KWA/(N)CDQ2KWA

Standard (Through-hole):
(N)CQ2KWB/(N)CDQ2KWB

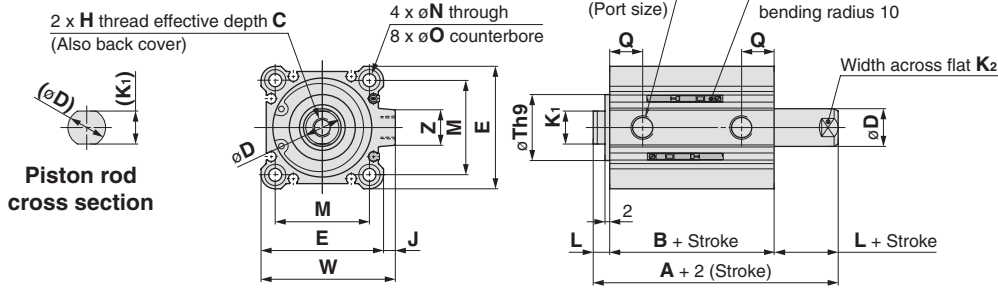

Both Ends Tapped Style

Bore size (mm)	CQ2 O1	NCQ2 O1 inch	R
40	M6 x 1.0	1/4-20UNC	10
50	M8 x 1.25	5/16-18UNC	14
63	M10 x 1.5	7/16-14UNC	18

Rod end male thread

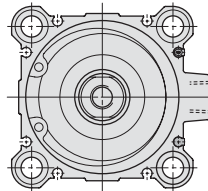
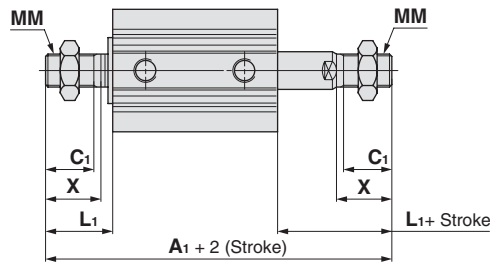

Cylinder tube form
ø63

CQ2 Rod End Male Thread

Bore size (mm)	Without auto switch	With auto switch	C1	MM	L1	X
	A1	A1				
40	97	107	20.5	M14 x 1.5	28.5	23.5
50	107.5	117.5	26	M18 x 1.5	33.5	28.5
63	109	119	26	M18 x 1.5	33.5	28.5

NCQ2 Rod End Male Thread

Bore size (mm)	Without auto switch	With auto switch	MM inch	L1	X
	A1	A1			
40	86	96	3/8-24UNF	23	16
50	95.5	105.5	1/2-20UNF	27.5	19.5
63	97	107	1/2-20UNF	27.5	19.5

*C1" dim. not applicable

Built-in one-touch fittings:
ø40 to ø63

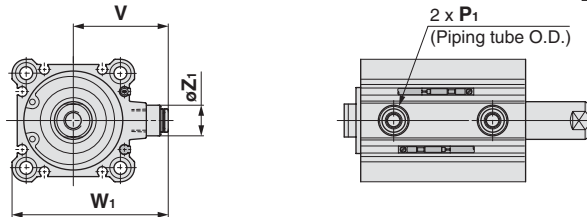

Built-in One-touch Fittings
(CQ2 only)

Bore size (mm)	Z1	P1	V	W1
40	13	6	40.5	66.5
50	16	8	50	82
63	16	8	56.5	95

Standard For auto switch proper mounting position and its mounting height, refer to pages 188 to 194.

(mm)

Bore size (mm)	Stroke range (mm)	Without auto switch		With auto switch		CQ2 C	NCQ2 C	D	E	CQ2 H	NCQ2 H inch	I	J	K1	K2	L	M	N	O	CQ2 P	NCQ2 P	Q	S	TH9	U	Z
		A	B	A	B																					
40	5 to 50	54	40	64	50	13	18.3	16	52	M8 x 1.25	3/8-24UNF	69	5	14	14	7	40	5.5	9 depth 7	Rc 1/8	NPT 1/8	14	66	28 ⁰ _{-0.052}	35	14
	Note 1) 75,100	64	50																							
50	10 to 50	56.5	40.5	66.5	50.5	15	17.6	20	64	M10 x 1.5	1/2-20UNF	86	7	18	17	8	50	6.6	11 depth 8	Rc 1/4	NPT 1/4	14	80	35 ⁰ _{-0.052}	41	19
	Note 1) 75,100	66.5	50.5																							
63	10 to 50	58	42	68	52	15	17.6	20	77	M10 x 1.5	1/2-20UNF	103	7	18	17	8	60	9	14 depth 10.5	Rc 1/4	NPT 1/4	15.5	93	35 ⁰ _{-0.052}	47.5	19
	Note 1) 75,100	68	52																							

* For details about the rod end nut and accessory brackets, refer to page 178.
Note) The positions of piston rod's width across flats (K2) are not constant.

Foot: (N)CQ2KWL/(N)CDQ2KWL

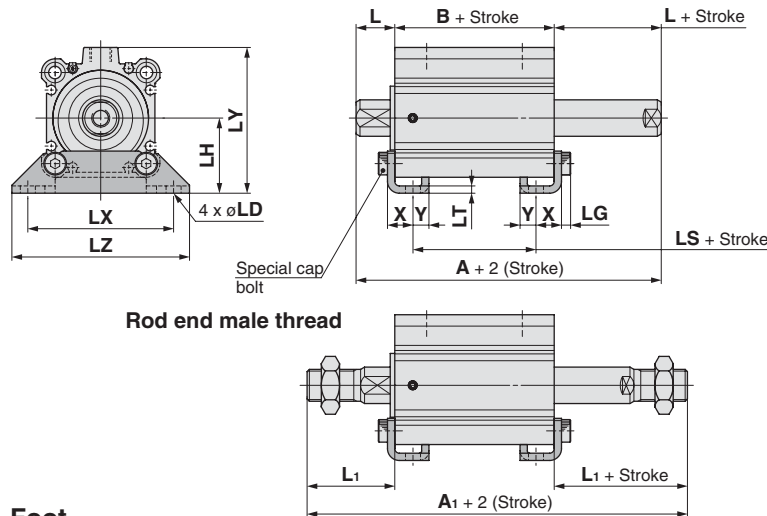

CQ2 Rod End Male Thread

Bore size (mm)	Without auto switch	With auto switch	L ₁
	A ₁	A ₁	
40	117	127	38.5
50	127.5	137.5	43.5
63	129	139	43.5

NCQ2 Rod End Male Thread

Bore size (mm)	Without auto switch	With auto switch	L ₁
	A ₁	A ₁	
40	106	116	33
50	115.5	125.5	37.5
63	117	127	37.5

Foot

Bore size (mm)	Stroke range (mm)	Without auto switch			With auto switch			L	LD	LG	LH	LT	LX	LY	LZ	X	Y
		A	B	LS	A	B	LS										
40	5 to 50	74	40	24	84	50	34	17	6.6	4	33	3.2	64	68	78	11.2	7
	75,100 ^{Note 1)}	84	50	34													
50	10 to 50	76.5	40.5	17.5	86.5	50.5	27.5	18	9	5	39	3.2	79	78	95	14.7	8
	75,100 ^{Note 1)}	86.5	50.5	27.5													
63	10 to 50	78	42	16	88	52	26	18	11	5	46	3.2	95	91.5	113	16.2	8
	75,100 ^{Note 1)}	88	52	26													

Note 1) 75 & 100mm stroke not available NCQ2.

Foot bracket material: Carbon steel

Flange: (N)CQ2KWF/(N)CDQ2KWF

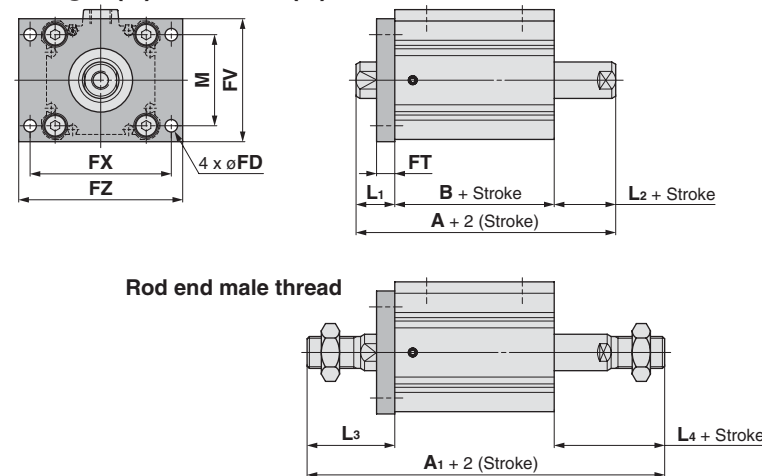

CQ2 Rod End Male Thread

Bore size (mm)	Without auto switch	With auto switch	L ₃	L ₂
	A ₁	A ₁		
40	107	117	38.5	28.5
50	117.5	127.5	43.5	33.5
63	119	129	43.5	33.5

NCQ2 Rod End Male Thread

Bore size (mm)	Without auto switch	With auto switch	L ₃	L ₂
	A ₁	A ₁		
40	96	106	33	23
50	105.5	115.5	37.5	27.5
63	107	117	37.5	27.5

For auto switch proper mounting position and its mounting height, refer to pages 188 to 194. (mm)

Bore size (mm)	Stroke range (mm)	Without auto switch		With auto switch		FD	FT	FV	FX	FZ	L ₁	L ₂	M
		A	B	A	B								
40	5 to 50	64	40	74	50	5.5	8	54	62	72	17	7	40
	75,100 ^{Note 1)}	74	50										
50	10 to 50	66.5	40.5	76.5	50.5	6.6	9	67	76	89	18	8	50
	75,100 ^{Note 1)}	76.5	50.5										
63	10 to 50	68	42	78	52	9	9	80	92	108	18	8	60
	75,100 ^{Note 1)}	78	52										

* For details about the rod end nut and accessory brackets, refer to page 178.

Flange bracket material: Carbon steel
Surface treatment: Nickel plated

Standard
Single Acting
Double Rod
Axial Piping
Water Resistant
High Lateral Load
End Lock
Clean Series
Copper/Fluorine free series
Construction and Parts
Warranty and Operating Instructions
Mounting and Auto Switches
Made to Order

How to Order

C D QP2 B [] 32 [] - 30 D [] - []

Magnet

Nil	Without magnet
D	With magnet

Mounting

B	Through hole (std.)
A	Threaded
D	Clevis
L	Foot
G	Head flange
F	Rod flange

* Mounting brackets are shipped together, (but not assembled).
 * Cylinder mounting bolts are not included. Order them separately referring to "Mounting Bolt for C(D)Q2B" on pages 156 and 157.

Type

Nil	Pneumatic
H	Air-hydro ^{Note 1)}

Note 1) Bore sizes available for air-hydro type are ø20 to ø100.

Bore size

12	12 mm
16	16 mm
20	20 mm
25	25 mm
32	32 mm
40	40 mm
50	50 mm
63	63 mm
80	80 mm
100	100 mm

Port thread type

Nil	Rc
TN	NPT
TF	G
F	One Touch

Switch

M9	Solid state switch (see page 181 for details)
A9	Reed switch

Body option

Nil	Standard (Rod end female thread)
F	With boss on head end
C	With rubber bumper ^{Note 4)}
M	Rod end male thread

Combination of body options ("CM", "FC", "FM", "FCM") is available.

Note 4) Air-hydro type with rubber bumper is not available.

Stroke standard (pneumatic)

Bore	Standard stroke										Long stroke							
	5	10	15	20	25	30	35	40	45	50	75	100	125	150	175	200	250	300
12	●	●	●	●	●	●	○	○	○	○	○							
16	●	●	●	●	●	●	○	○	○	○	○							
20	●	●	●	●	●	●	●	●	●	○	○							
25	●	●	●	●	●	●	●	●	●	○	○							
32	●	●	●	●	●	●	●	●	●	●	●	●	●	●	●	●	●	●
40	●	●	●	●	●	●	●	●	●	●	●	●	●	●	●	●	●	●
50		●	●	●	●	●	●	●	●	●	●	●	●	●	●	●	●	●
63		●	●	●	●	●	●	●	●	●	●	●	●	●	●	●	●	●
80		●	●	●	●	●	●	●	●	●	●	●	●	●	●	●	●	●
100		●	●	●	●	●	●	●	●	●	●	●	●	●	●	●	●	●

● Standard normally stocked
 ○ Manufactured option

- Standard
- Single Acting
- Double Rod
- Axial Piping**
- Water Resistant
- High Lateral Load
- End Lock
- Clean Series
- Copper/Fluorine free series
- Construction and Parts
- Warranty and Operating Instructions
- Mounting and Auto Switches
- Made to Order

Series CQP2

Double Acting, Single Rod Specifications - Axial Piping



Rod end male thread

JIS Symbol
Double acting,
Single rod

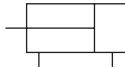

Specifications

Pneumatic type

Bore size (mm)		12	16	20	25	32	40	50	63	80	100
Action	Double acting, Single rod										
Fluid	Air										
Proof pressure	218 psi (1.5 MPa)										
Maximum operating pressure	145 psi (1.0 MPa)										
Minimum operating pressure	10.3 psi (0.07 MPa)	7.3 psi (0.05 MPa)									
Ambient and fluid temperature	Without auto switch: -10 to 70°C (No freezing) With auto switch: -10 to 60°C (No freezing)										
Lubrication	Not required (Non-lube)										
Piston speed	50 to 500 mm/s										
Allowable kinetic energy (J)	Without cushion	0.022	0.038	0.055	0.09	0.15	0.26	0.46	0.77	1.36	2.27
	With rubber bumper	0.043	0.075	0.11	0.18	0.29	0.52	0.91	1.54	2.71	4.54
Stroke length tolerance	+1.0 mm (Note) 0										

Note) Stroke length tolerance does not include the amount of bumper change.

Air-hydro type

Bore size (mm)		20	25	32	40	50	63	80	100
Action	Double acting, Single rod								
Fluid	Turbine oil (Note)								
Proof pressure	218 psi (1.5 MPa)								
Maximum operating pressure	145 psi (1.0 MPa)								
Minimum operating pressure	26 psi (0.18 MPa)	14.5 (0.1 MPa)							
Ambient and fluid temperature	5 to 60°C								
Piston speed	5 to 50 mm/s								
Cushion	None								
Stroke length tolerance	+1.0 mm 0								

Note) Refer to "Handling Precautions for SMC Products" (M-E03-3) for Actuator Precautions (5).

Standard Strokes

Pneumatic type (Non-lube) (mm)

Bore size	Standard stroke
12, 16	5, 10, 15, 20, 25, 30
20, 25	5, 10, 15, 20, 25, 30, 35 40, 45, 50
32, 40	5, 10, 15, 20, 25, 30, 35 40, 45, 50, 75, 100
50, 63 80, 100	10, 15, 20, 25, 30, 35, 40 45, 50, 75, 100

Air-hydro type (mm)

Bore size	Standard stroke
20, 25	5, 10, 15, 20, 25, 30, 35 40, 45, 50
32, 40	5, 10, 15, 20, 25, 30, 35 40, 45, 50, 75, 100
50, 63 80, 100	10, 15, 20, 25, 30, 35, 40 45, 50, 75, 100

Manufacture of Intermediate Strokes

Type	A spacer is installed in the standard stroke body.	
Part no.	Refer to "How to Order" for the standard model number. (P. 77)	
Description	Strokes in 1 mm intervals are available by installing a spacer in the standard stroke cylinder.	
Stroke range	Bore size	Stroke range
	12, 16	1 to 29
	20, 25	1 to 49
	32 to 100	1 to 99
Example	Part no.: CQP2B50-57D CQP2B50-75D with 18 mm width spacer inside The B dimension is 115.5 mm.	

- Except air-hydro type
- In the case of spacer type, intermediate strokes with bumper for ø40 to ø100, it can be manufactured in 5 mm intervals in 5 mm and 55 to 95 mm.

Conversions

°F = 1.8°C + 32 1 J = 0.738 ft-lb
1 MPa = 145 psi 1 mm = 0.039 in

Type

		Bore size (mm)									
		12	16	20	25	32	40	50	63	80	100
Pneumatic	Mounting Through-hole (Std.)	●	●	●	●	●	●	●	●	●	●
	Built-in magnet	●	●	●	●	●	●	●	●	●	●
	Piping Pipe thread	M5 x 0.8	M5 x 0.8	M5 x 0.8	M5 x 0.8	Rc1/8 NPT1/8	Rc1/8 NPT1/8	Rc1/4 NPT1/4	Rc1/4 NPT1/4	Rc3/8 NPT3/8	Rc3/8 NPT3/8
	Rod end male thread	●	●	●	●	●	●	●	●	●	●
	With rubber bumper	●	●	●	●	●	●	●	●	●	●
Air-hydro	Mounting Through-hole (Std.)	—	—	●	●	●	●	●	●	●	●
	Built-in magnet	—	—	●	●	●	●	●	●	●	●
	Piping Pipe thread	—	—	M5 x 0.8	M5 x 0.8	Rc1/8	Rc1/8	Rc1/4	Rc1/4	Rc3/8	Rc3/8
	Rod end male thread	—	—	●	●	●	●	●	●	●	●

Theoretical Output



Bore size (mm)	Operating direction	Operating pressure (MPa)		
		0.3	0.5	0.7
12	IN	25	42	59
	OUT	34	57	79
16	IN	45	75	106
	OUT	60	101	141
20	IN	71	118	165
	OUT	94	157	220
25	IN	113	189	264
	OUT	147	245	344
32	IN	181	302	422
	OUT	241	402	563
40	IN	317	528	739
	OUT	377	628	880
50	IN	495	825	1150
	OUT	589	982	1370
63	IN	841	1400	1960
	OUT	935	1560	2180
80	IN	1360	2270	3170
	OUT	1510	2510	3520
100	IN	2140	3570	5000
	OUT	2360	3930	5500

Weight

Bore size (mm)	Cylinder stroke (mm)											
	5	10	15	20	25	30	35	40	45	50	75	100
12	32	39	46	53	60	67	—	—	—	—	—	—
16	54	63	72	81	90	98	—	—	—	—	—	—
20	70	84	98	112	126	140	154	168	182	196	—	—
25	102	117	132	147	161	176	191	206	220	235	—	—
32	149	173	199	222	246	270	295	319	343	367	487	607
40	224	258	280	310	336	362	388	414	440	467	602	737
50	—	414	455	496	538	579	620	662	703	744	949	1154
63	—	584	632	679	727	774	822	870	917	965	1205	1445
80	—	1085	1163	1242	1320	1399	1477	1556	1634	1713	2108	2503
100	—	1894	1992	2091	2189	2287	2385	2483	2581	2679	3169	3659

Additional Weight

Bore size (mm)		12	16	20	25	32	40	50	63	80	100
Rod end male thread	Male thread	1.5	3	6	12	26	27	53	53	120	175
	Nut	1	2	4	8	17	17	32	32	49	116
	With rubber bumper	0	0	-2	-3	-3	-7	-9	-18	-31	-56

Calculation: (Example) **CQP2B32-20DCM**

- Basic weight: CQP2B32-20D..... 222 g
 - Additional weight: Rod end male thread..... 43 g
 - With rubber bumper.....-3 g
- 262 g

1g = 0.0353 oz
 1kg = 2.2046 lb
 1N = 0.2248 lbf

Standard

Single Acting

Double Rod

Axial Piping

Water Resistant

High Lateral Load

End Lock

Clean Series

Copper/Fluorine free series

Construction and Parts

Warranty and Operating Instructions

Mounting and Auto Switches

Made to Order

Series CQP2 Double Acting, Single Rod

Technical Information - Axial Piping

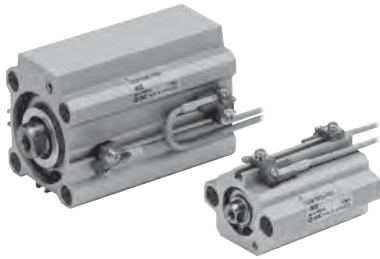

Refer to the below pages for further information on auto switches.

Auto switch proper mounting position and its mounting height	P.188 to 194
Minimum stroke for auto switch mounting	
Operating range	
Auto switch mounting brackets/Part no.	

Weight

Bore size (mm)	Cylinder stroke (mm)											
	5	10	15	20	25	30	35	40	45	50	75	100
12	54	62	69	75	82	89	—	—	—	—	—	—
16	91	99	107	115	123	131	—	—	—	—	—	—
20	121	135	147	161	175	188	201	214	228	242	—	—
25	177	190	203	217	230	244	257	270	284	297	—	—
32	217	242	266	290	315	339	363	387	412	436	557	679
40	319	345	371	397	423	449	475	502	528	554	684	814
50	—	546	588	629	670	712	753	794	836	877	1084	1291
63	—	764	812	859	907	955	1002	1050	1098	1145	1384	1622
80	—	1377	1455	1534	1612	1691	1769	1848	1926	2005	2397	2790
100	—	2296	2394	2492	2590	2688	2786	2884	2982	3080	3570	4060

Additional Weight

Bore size (mm)		12	16	20	25	32
Rod end male thread	Male thread	1.5	3	6	12	26
	Nut	1	2	4	8	17
With rubber bumper		0	-1	-2	-3	-3

Bore size (mm)		40	50	63	80	100
Rod end male thread	Male thread	27	53	53	120	175
	Nut	17	32	32	49	116
With rubber bumper		-7	-9	-18	-31	-56

Auto Switch Mounting Bracket/Weight

Mounting bracket part no.	Applicable bore size	Weight (g)
BQ-1	ø12 to ø25	1.5
BQ-2	ø32 to ø100	1.5
BQ2-012	ø12 to ø100	5

Calculation: (Example) **CDQP2B32-20DCM**

- Basic weight: CDQP2B32-20D..... 290 g
- Additional weight: Rod end male thread... 43 g
- With rubber bumper..... 3 g
- 330 g

1g = 0.0353 oz
1kg = 2.2046 lb
1N = 0.2248 lbf

Add weight of each auto switch when auto switches are mounted.

ø12 to ø100 - Without Auto Switch

ø12 to ø25

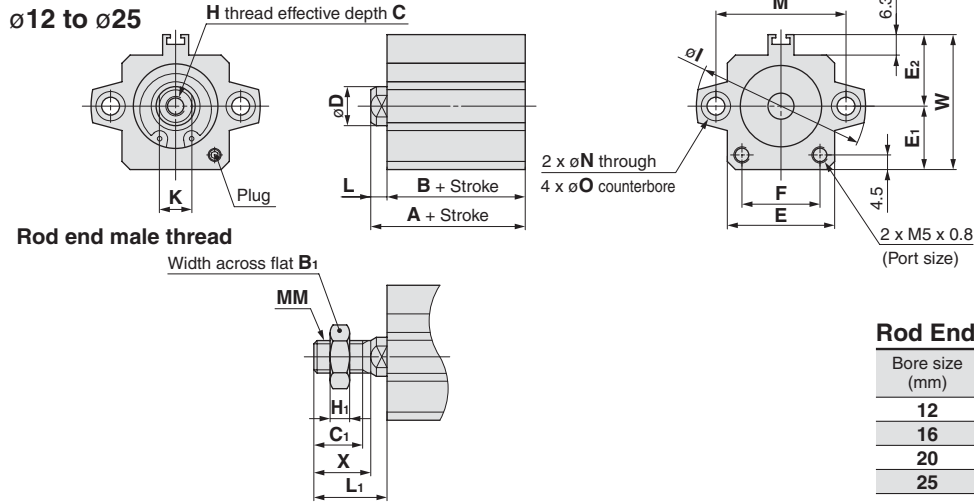

Rod End Male Thread (mm)

Bore size (mm)	B ₁	C ₁	H ₁	L ₁	MM	X
12	8	9	4	14	M5 x 0.8	10.5
16	10	10	5	15.5	M6 x 1.0	12
20	13	12	5	18.5	M8 x 1.25	14
25	17	15	6	22.5	M10 x 1.25	17.5

Standard

(mm)

Bore size (mm)	Stroke range (mm)	A	B	C	D	E	E ₁	E ₂	F	H	I	K	L	M	N	O	W
12	5 to 30	20.5	17	6	6	23	13	14	14	M3 x 0.5	32	5	3.5	22	3.5	6.5 depth 3.5	27
16	5 to 30	22	18.5	8	8	26	15	17	17	M4 x 0.7	38	6	3.5	28	3.5	6.5 depth 3.5	32
20	5 to 50	24	19.5	7	10	30	17	19	21	M5 x 0.8	47	8	4.5	36	5.5	9 depth 7	36
25	5 to 50	27.5	22.5	12	12	33	19.5	22	24	M6 x 1.0	52	10	5	40	5.5	9 depth 7	41.5

ø32 to ø100

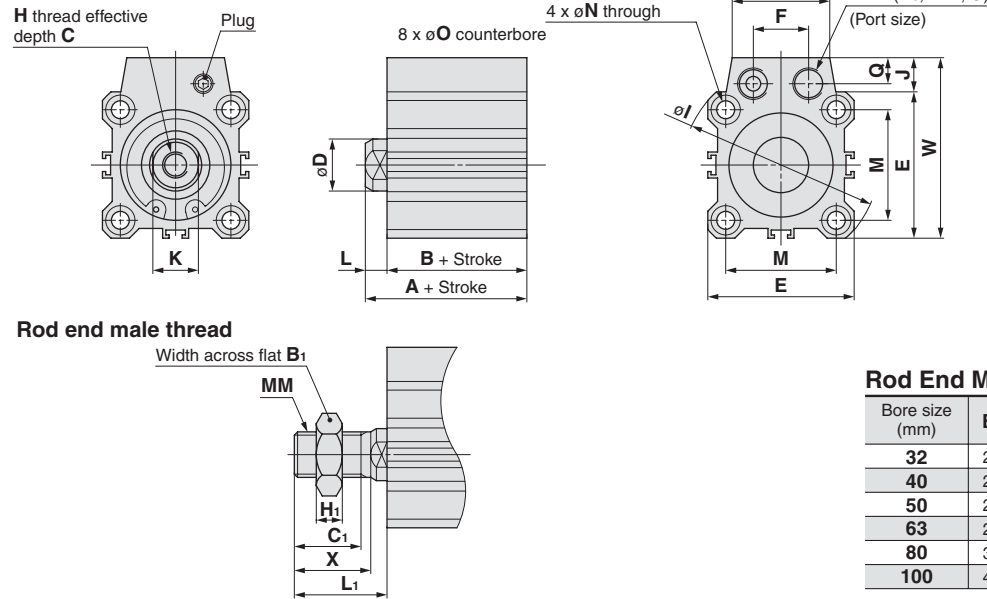

Rod End Male Thread (mm)

Bore size (mm)	B ₁	C ₁	H ₁	L ₁	MM	X
32	22	20.5	8	28.5	M14 x 1.5	23.5
40	22	20.5	8	28.5	M14 x 1.5	23.5
50	27	26	11	33.5	M18 x 1.5	28.5
63	27	26	11	33.5	M18 x 1.5	28.5
80	32	32.5	13	43.5	M22 x 1.5	35.5
100	41	32.5	16	43.5	M26 x 1.5	35.5

Standard

(mm)

Bore size (mm)	Stroke range (mm)	A	B	C	D	E	F	H	I	J	K	L	M	N	O	P	Q	W	Z
32	5 to 50	30	23	13	16	45	17	M8 x 1.25	60	10.5	14	7	34	5.5	9 depth 7	1/8	8	55.5	30
	75, 100	40	33																
40	5 to 50	36.5	29.5	13	16	52	17	M8 x 1.25	69	10	14	7	40	5.5	9 depth 7	1/8	8	62	30
	75, 100	46.5	39.5																
50	10 to 50	38.5	30.5	15	20	64	22	M10 x 1.5	86	13	17	8	50	6.6	11 depth 8	1/4	10	77	39
	75, 100	48.5	40.5																
63	10 to 50	44	36	15	20	77	22	M10 x 1.5	103	13	17	8	60	9	14 depth 10.5	1/4	10	90	39
	75, 100	54	46																
80	10 to 50	53.5	43.5	21	25	98	26	M16 x 2.0	132	16	22	10	77	11	17.5 depth 13.5	3/8	12.5	114	48
	75, 100	63.5	53.5																
100	10 to 50	65	53	27	30	117	26	M20 x 2.5	156	17.5	27	12	94	11	17.5 depth 13.5	3/8	12.5	134.5	48
	75, 100	75	63																

Note) The external dimensions with rubber bumper are the same as those of the standard, as shown above.
* For details about the rod end nut and accessory brackets, refer to page 178.

- Standard
- Single Acting
- Double Rod
- Axial Piping**
- Water Resistant
- High Lateral Load
- End Lock
- Clean Series
- Copper/Fluorine free series
- Construction and Parts
- Warranty and Operating Instructions
- Mounting and Auto Switches
- Made to Order

ø12 to ø100 - With Auto Switch

ø12 to ø25

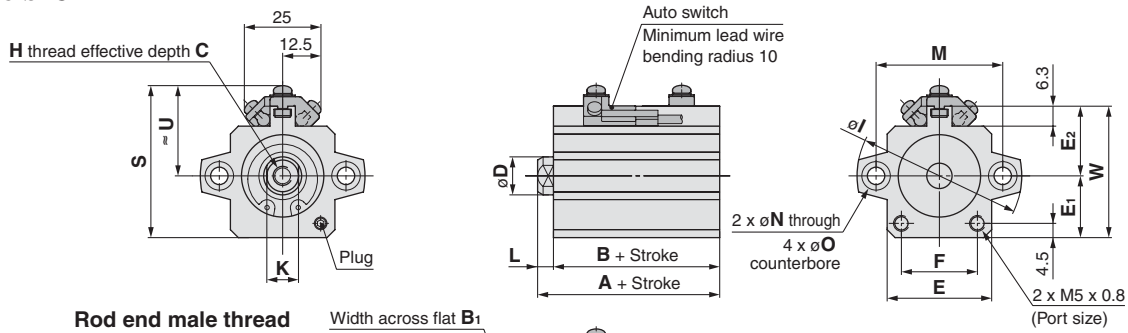

Rod end male thread

Width across flat B₁

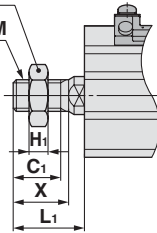

Rod End Male Thread (mm)

Bore size (mm)	B ₁	C ₁	H ₁	L ₁	MM	X
12	8	9	4	14	M5 x 0.8	10.5
16	10	10	5	15.5	M6 x 1.0	12
20	13	12	5	18.5	M8 x 1.25	14
25	17	15	6	22.5	M10 x 1.25	17.5

For auto switch proper mounting position and its mounting height, refer to pages 196 to 198.

Standard

Bore size (mm)	Stroke range (mm)	A	B	C	D	E	E ₁	E ₂	F	H	I	K	L	M	N	O	S	U	W
12	5 to 30	31.5	28	6	6	23	13	14	14	M3 x 0.5	32	5	3.5	22	3.5	6.5 depth 3.5	33.5	20.5	27
16	5 to 30	34	30.5	8	8	26	15	17	17	M4 x 0.7	38	6	3.5	28	3.5	6.5 depth 3.5	38.5	23.5	32
20	5 to 50	36	31.5	7	10	30	17	19	21	M5 x 0.8	47	8	4.5	36	5.5	9 depth 7	42.5	25.5	36
25	5 to 50	37.5	32.5	12	12	33	19.5	22	24	M6 x 1.0	52	10	5	40	5.5	9 depth 7	48	28.5	41.5

Note) The external dimensions with rubber bumper are the same as those of the standard, as shown above.

ø32 to ø100

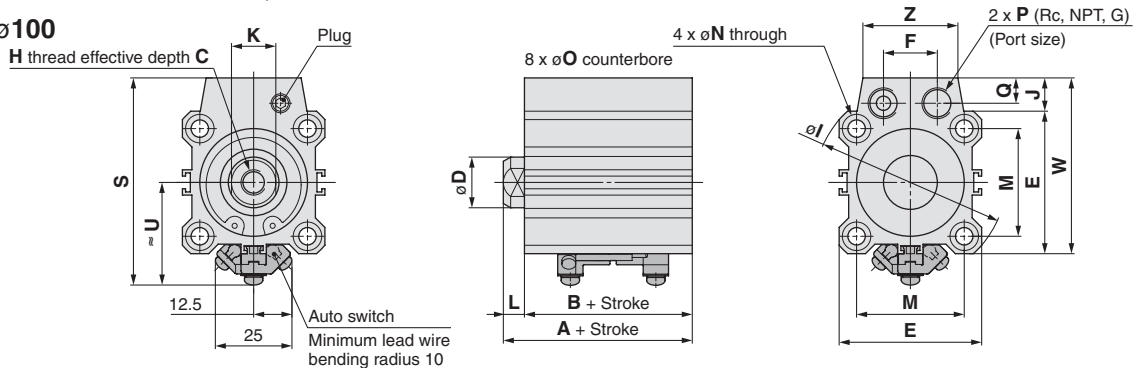

Rod end male thread

Width across flat B₁

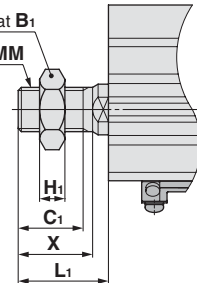

Rod End Male Thread (mm)

Bore size (mm)	B ₁	C ₁	H ₁	L ₁	MM	X
32	22	20.5	8	28.5	M14 x 1.5	23.5
40	22	20.5	8	28.5	M14 x 1.5	23.5
50	27	26	11	33.5	M18 x 1.5	28.5
63	27	26	11	33.5	M18 x 1.5	28.5
80	32	32.5	13	43.5	M22 x 1.5	35.5
100	41	32.5	16	43.5	M26 x 1.5	35.5

For auto switch proper mounting position and its mounting height, refer to pages 196 to 198.

Standard

Bore size (mm)	Stroke range (mm)	A	B	C	D	E	F	H	I	J	K	L	M	N	O	P	Q	S	U	W	Z
32	5 to 100	40	33	13	16	45	17	M8 x 1.25	60	10.5	14	7	34	5.5	9 depth 7	1/8	8	65.5	32.5	55.5	30
40	5 to 100	46.5	39.5	13	16	52	17	M8 x 1.25	69	10	14	7	40	5.5	9 depth 7	1/8	8	72	36	62	30
50	10 to 100	48.5	40.5	15	20	64	22	M10 x 1.5	86	13	17	8	50	6.6	11 depth 8	1/4	10	87	42	77	39
63	10 to 100	54	46	15	20	77	22	M10 x 1.5	103	13	17	8	60	9	14 depth 10.5	1/4	10	100	48.5	90	39
80	10 to 100	63.5	53.5	21	25	98	26	M16 x 2.0	132	16	22	10	77	11	17.5 depth 13.5	3/8	12.5	123.5	58.5	114	48
100	10 to 100	75	63	27	30	117	26	M20 x 2.5	156	17.5	27	12	94	11	17.5 depth 13.5	3/8	12.5	144.5	68.5	134.5	48

Note) The external dimensions with rubber bumper are the same as those of the standard, as shown above.

* For details about the rod end nut and accessory brackets, refer to page 178.

How to Order

C D QP2 B [] 32 [] - 30 T [] - []

Magnet

Nil	Without magnet
D	With magnet

Mounting

B	Through hole (std.)
A	Threaded
D	Clevis
L	Foot
G	Head flange
F	Rod flange

* Mounting brackets are shipped together, (but not assembled).
 * Cylinder mounting bolts are not included. Order them separately referring to "Mounting Bolt for C(D)Q2B" on pages 156 and 157.

Type

Nil	Pneumatic
H	Air-hydro ^{Note 1)}

Note 1) Bore sizes available for air-hydro type are ø20 to ø100.

Bore size

12	12 mm
16	16 mm
20	20 mm
25	25 mm
32	32 mm
40	40 mm
50	50 mm

Port thread type

Nil	Rc
TN	NPT
TF	G
F	One Touch

Switch

M9	Solid state switch (see page 181 for details)
A9	Reed switch

Body option

Nil	Standard (Rod end female thread)
F	With boss on head end
C	With rubber bumper ^{Note 4)}
M	Rod end male thread

Combination of body options ("CM", "FC", "FM", "FCM") is available.

Note 4) Air-hydro type with rubber bumper is not available.

Action

S	Single acting, Spring return
T	Single acting, Spring extend

Stroke standard (pneumatic)

Bore	5	10	15	20
12	●	●	●	●
16	●	●	●	●
20	●	●	●	●
25	●	●	●	●
32	●	●	●	●
40	●	●	●	●
50	●	●	●	●

● Standard normally stocked

- Standard
- Single Acting
- Double Rod
- Axial Piping**
- Water Resistant
- High Lateral Load
- End Lock
- Clean Series
- Copper/Fluorine free series
- Construction and Parts
- Warranty and Operating Instructions
- Mounting and Auto Switches
- Made to Order

Series CQP2

Single Acting, Single Rod Specifications - Axial Piping



JIS Symbol

Single acting,
Spring return

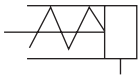

Single acting,
Spring extend

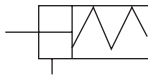

Specifications

Bore size (mm)	12	16	20	25	32	40	50
Action	Double acting, Single rod						
Fluid	Air						
Proof pressure	218 psi (1.5 MPa)						
Maximum operating pressure	145 psi (1.0 MPa)						
Minimum operating pressure (MPa)	0.25	0.25	0.18	0.18	0.17	0.15	0.13
Ambient and fluid temperature	Without auto switch: -10 to 70°C (No freezing) With auto switch: -10 to 60°C (No freezing)						
Lubrication	Not required (Non-lube)						
Piston speed	50 to 500 mm/s						
Allowable kinetic energy (J)	0.022	0.038	0.055	0.09	0.15	0.26	0.46
Stroke length tolerance	+1.0 mm 0						

Standard Strokes

Bore size	Standard stroke (mm)
12	5, 10
16	
20	
25	
32	
40	
50	10, 20

Manufacture of Intermediate Strokes

(Except single acting, spring return)

Type	A spacer is installed in the standard stroke body.	
Part no.	Refer to "How to Order" for the standard model number. (P. 83)	
Description	Strokes in 1 mm intervals are available by installing a spacer in the standard stroke cylinder.	
Stroke range	Bore size	Stroke range
	12 to 40	1 to 9
	50	1 to 19
Example	Part no.: CQP2B20-3T CQP2B20-5T with 2 mm width spacer inside The B dimension is 24.5 mm.	

Type

Bore size (mm)		12	16	20	25	32	40	50	
Pneumatic	Mounting	Through-hole (Standard)	●	●	●	●	●	●	
		Built-in magnet	●	●	●	●	●	●	
	Piping	Pipe thread	M5 x 0.8	M5 x 0.8	M5 x 0.8	M5 x 0.8	Rc1/8	Rc1/8	Rc1/4
							NPT1/8	NPT1/8	NPT1/4
							G1/8	G1/8	G1/4
	Rod end male thread	●	●	●	●	●	●	●	

Refer to pages 196 to 198 for the specifications of cylinders with autoswitches.

- Auto switch proper mounting position (detection at stroke end) and its mounting height
- Minimum stroke for auto switch mounting
- Operating range
- Auto switch mounting brackets/Part no.

Conversions

°F = 1.8°C + 32 1 J = 0.738 ft-lb
1 MPa = 145 psi 1 mm = 0.039 in

Theoretical Output

Action	Bore size (mm)	Operating pressure (MPa)		
		0.3	0.5	0.7
Spring return	12	21	44	66
	16	45	86	126
	20	79	142	205
	25	126	224	323
	32	211	372	533
	40	338	589	841
	50	535	928	1316
Spring extend	12	14	31	48
	16	24	54	85
	20	71	118	165
	25	113	189	264
	32	181	302	422
	40	317	528	739
	50	495	825	1150

Weight

Action	Bore size (mm)	Cylinder stroke (mm)			
		5	10	15	20
Spring return	12	33	40	—	—
	16	55	64	—	—
	20	68	83	—	—
	25	103	118	—	—
	32	149	173	—	—
	40	236	262	—	—
	50	—	426	—	691
Spring extend	12	33	40	—	—
	16	55	64	—	—
	20	73	87	—	—
	25	109	124	—	—
	32	160	180	—	—
	40	262	284	—	—
	50	—	468	—	540

Spring Force

Single Acting, Spring Return (N)

Bore size (mm)	Stroke (mm)	Spring reaction force (N)	
		Second	First
12	5	13	8.6
	10	13	3.9
16	5	15	10.3
	10	15	5.9
20	5	15	10
	10	15	5.9
25	5	20	16
	10	20	11
32	5	30	23
	10	30	16
40	5	30	13
	10	39	21
50	10	50	30
	20	54	24

Single acting, Spring return

Spring state with first mounting load

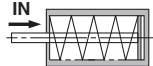

When spring is set in cylinder

Spring state with second mounting load

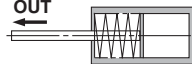

When spring is compressed with air

Single Acting, Spring Extend (N)

Bore size (mm)	Stroke (mm)	Spring reaction force (N)	
		Second	First
12	5	11	2.9
	10	9.7	2.8
16	5	20	3.9
	10	20	3.9
20	5	27	5.3
	10	27	5.9
25	5	29	9.8
	10	29	9.8
32	5	29	20
	10	29	20
40	5	29	20
	10	29	20
50	10	83	24
	20	83	24

Single acting, Spring extend

Spring state with first mounting load



When spring is set in cylinder

Spring state with second mounting load

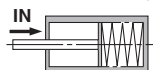

When spring is compressed with air

Additional Weight

Bore size (mm)		12	16	20	25	32	40	50
Rod end male thread	Male thread	1.5	3	6	12	26	27	53
	Nut	1	2	4	8	17	17	32

Calculation: (Example) **CQP2B32-10SM**

- Basic weight: CQP2B32-10S 173 g
 - Additional weight: Rod end male thread 43 g
- 216 g

1g = 0.0353 oz
 1kg = 2.2046 lb
 1N = 0.2248 lbf

Standard
 Single Acting
 Double Rod
Axial Piping
 Water Resistant
 High Lateral Load
 End Lock
 Clean Series
 Copper/Fluorine free series
 Construction and Parts
 Warranty and Operating Instructions
 Mounting and Auto Switches
 Made to Order

Series CQP2

Single Acting, Single Rod

Technical Information - Axial Piping



Refer to the below pages for further information on auto switches.

Auto switch proper mounting position and its mounting height	P.196 to 198
Minimum stroke for auto switch mounting	
Operating range	
Auto switch mounting brackets/Part no.	

Weight

(g)

Action	Bore size (mm)	Cylinder stroke (mm)			
		5	10	15	20
Spring return	12	55	63	—	—
	16	92	100	—	—
	20	121	135	—	—
	25	178	191	—	—
	32	217	242	—	—
	40	323	349	—	—
Spring extend	50	—	558	—	641
	12	61	69	—	—
	16	92	100	—	—
	20	126	140	—	—
	25	184	197	—	—
	32	228	253	—	—
40	349	375	—	—	
50	—	600	—	683	

Additional Weight

(g)

Bore size (mm)		12	16	20	25	32	40	50
Rod end	Male thread	1.5	3	6	12	26	27	53
male thread	Nut	1	2	4	8	17	17	32

Calculation: (Example) **CDQP2B32-10SM** Add each weight of auto
 • Basic weight: CDQP2B32-10S 242 g switches when auto
 • Additional weight: Rod end male thread ... 43 g switches are mounted.
 285 g

1g = 0.0353 oz
1kg = 2.2046 lb
1N = 0.2248 lbf

ø12 to ø50 Spring Return - Without Auto Switch

ø12 to ø25

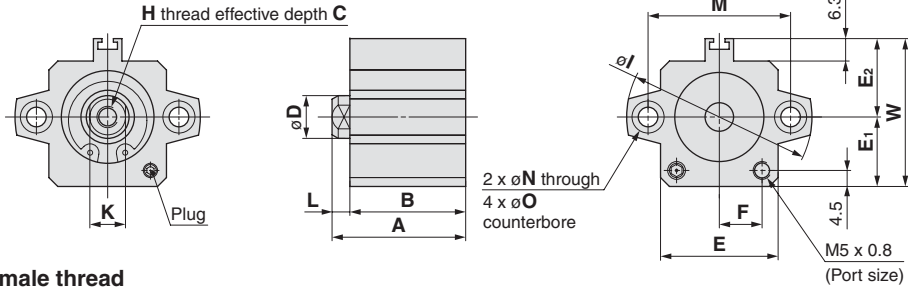

Rod end male thread

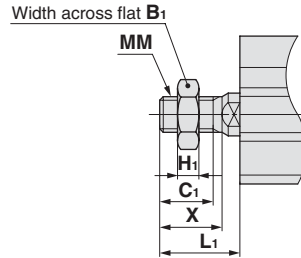

Rod End Male Thread

Bore size (mm)	B ₁	C ₁	H ₁	L ₁	MM	X
12	8	9	4	14	M5 x 0.8	10.5
16	10	10	5	15.5	M6 x 1.0	12
20	13	12	5	18.5	M8 x 1.25	14
25	17	15	6	22.5	M10 x 1.25	17.5

Standard

Bore size (mm)	A		B		C	D	E	E ₁	E ₂	F	H	I	K	L	M	N	O	W
	5st	10st	5st	10st														
12	25.5	30.5	22	27	6	6	23	13	14	7	M3 x 0.5	32	5	3.5	22	3.5	6.5 depth 3.5	27
16	27	32	23.5	28.5	8	8	26	15	17	8.5	M4 x 0.7	38	6	3.5	28	3.5	6.5 depth 3.5	32
20	29	34	24.5	29.5	7	10	30	17	19	10.5	M5 x 0.8	47	8	4.5	36	5.5	9 depth 7	36
25	32.5	37.5	27.5	32.5	12	12	33	19.5	22	12	M6 x 1.0	52	10	5	40	5.5	9 depth 7	41.5

ø32 to ø50

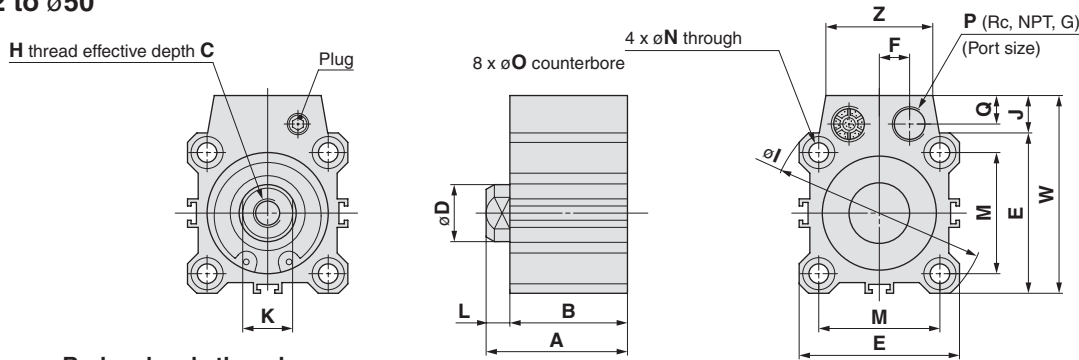

Rod end male thread

Rod End Male Thread

Bore size (mm)	B ₁	C ₁	H ₁	L ₁	MM	X
32	22	20.5	8	28.5	M14 x 1.5	23.5
40	22	20.5	8	28.5	M14 x 1.5	23.5
50	27	26	11	33.5	M18 x 1.5	28.5

Standard

Bore size (mm)	A			B			C	D	E	F	H	I	J	K	L	M	N	O	P	Q	W	Z
	5st	10st	20st	5st	10st	20st																
32	35	40	—	28	33	—	13	16	45	8.5	M8 x 1.25	60	10.5	14	7	34	5.5	9 depth 7	1/8	8	55.5	30
40	41.5	46.5	—	34.5	39.5	—	13	16	52	8.5	M8 x 1.25	69	10	14	7	40	5.5	9 depth 7	1/8	8	62	30
50	—	48.5	58.5	—	40.5	50.5	15	20	64	11	M10 x 1.5	86	13	17	8	50	6.6	11 depth 8	1/4	10	77	39

* For details about the rod end nut and accessory brackets, refer to page 178.

Standard
Single Acting
Double Rod
Axial Piping
Water Resistant
High Lateral Load
End Lock
Clean Series
Copper/Fluorine free series
Construction and Parts
Warranty and Operating Instructions
Mounting and Auto Switches
Made to Order

ø12 to ø50 Spring Return - With Auto Switch

ø12 to ø25

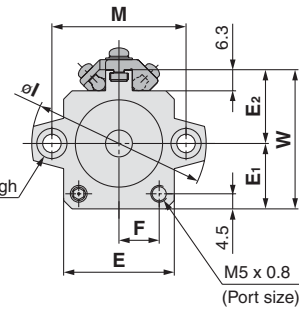
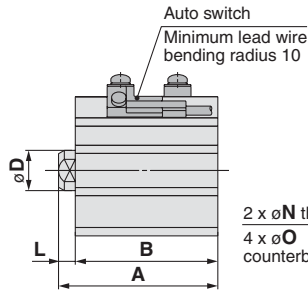
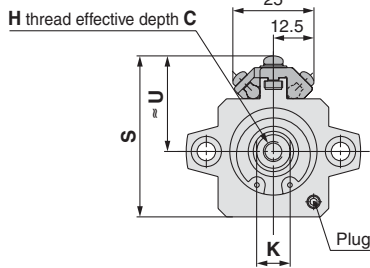

Rod end male thread

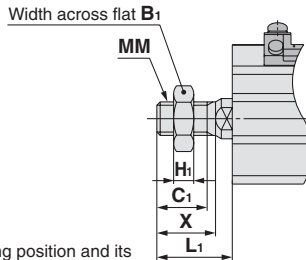

Rod End Male Thread

Bore size (mm)	B ₁	C ₁	H ₁	L ₁	MM	X
12	8	9	4	14	M5 x 0.8	10.5
16	10	10	5	15.5	M6 x 1.0	12
20	13	12	5	18.5	M8 x 1.25	14
25	17	15	6	22.5	M10 x 1.25	17.5

Standard

For auto switch proper mounting position and its mounting height, refer to pages 196 to 198.

Bore size (mm)	A		B			C	D	E	E ₁	E ₂	F	H	I	K	L	M	N	O	S	U	W
	5st	10st	5st	10st	10st																
12	36.5	41.5	33	38	6	6	23	13	14	7	M3 x 0.5	32	5	3.5	22	3.5	6.5 depth 3.5	33.5	20.5	27	
16	39	44	35.5	40.5	8	8	26	15	17	8.5	M4 x 0.7	38	6	3.5	28	3.5	6.5 depth 3.5	38.5	23.5	32	
20	41	46	36.5	41.5	7	10	30	17	19	10.5	M5 x 0.8	47	8	4.5	36	5.5	9 depth 7	42.5	25.5	36	
25	42.5	47.5	37.5	42.5	12	12	33	19.5	22	12	M6 x 1.0	52	10	5	40	5.5	9 depth 7	48	28.5	41.5	

ø32 to ø50

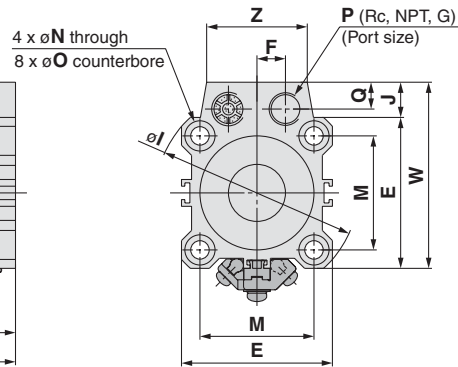
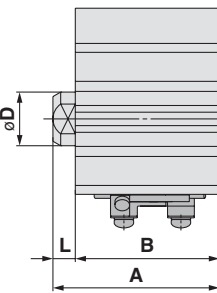
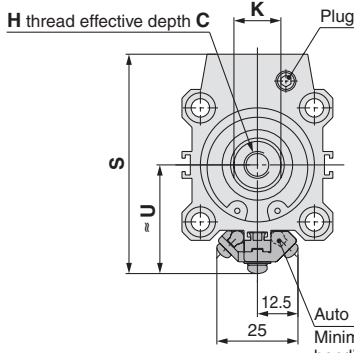

Rod end male thread

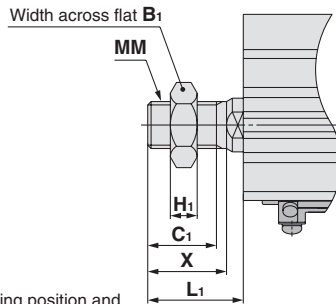

Rod End Male Thread

Bore size (mm)	B ₁	C ₁	H ₁	L ₁	MM	X
32	22	20.5	8	28.5	M14 x 1.5	23.5
40	22	20.5	8	28.5	M14 x 1.5	23.5
50	27	26	11	33.5	M18 x 1.5	28.5

Standard

For auto switch proper mounting position and its mounting height, refer to pages 196 to 198.

Bore size (mm)	A			B			C	D	E	F	H	I	J	K	L	M	N	O	P	Q	S	U	W	Z
	5st	10st	20st	5st	10st	20st																		
32	45	50	—	38	43	—	13	16	45	8.5	M8 x 1.25	60	10.5	14	7	34	5.5	9 depth 7	1/8	8	65.5	32.5	55.5	30
40	51.5	56.5	—	44.5	49.5	—	13	16	52	8.5	M8 x 1.25	69	10	14	7	40	5.5	9 depth 7	1/8	8	72	36	62	30
50	—	58.5	68.5	—	50.5	60.5	15	20	64	11	M10 x 1.5	86	13	17	8	50	6.6	11 depth 8	1/4	10	87	42	77	39

* For details about the rod end nut and accessory brackets, refer to page 178.

ø12 to ø50 Spring Extend - Without Auto Switch

ø12 to ø25

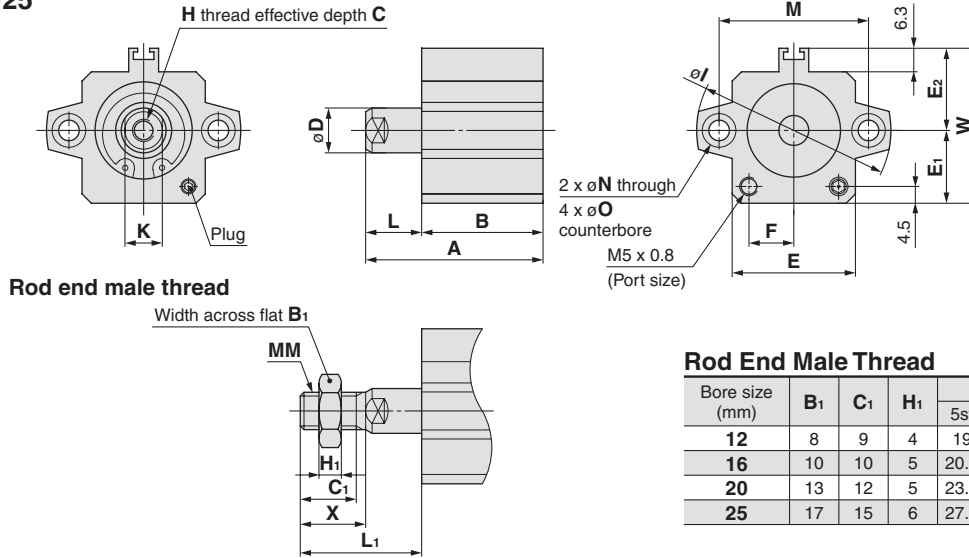

Rod End Male Thread (mm)

Bore size (mm)	B ₁	C ₁	H ₁	L ₁		MM	X
				5st	10st		
12	8	9	4	19	24	M5 x 0.8	10.5
16	10	10	5	20.5	25.5	M6 x 1.0	12
20	13	12	5	23.5	28.5	M8 x 1.25	14
25	17	15	6	27.5	32.5	M10 x 1.25	17.5

Standard

Bore size (mm)	A		B		C	D	E	E ₁	E ₂	F	H	I	K	L		M	N	O	W
	5st	10st	5st	10st										5st	10st				
12	30.5	40.5	22	27	6	6	23	13	14	7	M3 x 0.5	32	5	8.5	13.5	22	3.5	6.5 depth 3.5	27
16	32	42	23.5	28.5	8	8	26	15	17	8.5	M4 x 0.7	38	6	8.5	13.5	28	3.5	6.5 depth 3.5	32
20	34	44	24.5	29.5	7	10	30	17	19	10.5	M5 x 0.8	47	8	9.5	14.5	36	5.5	9 depth 7	36
25	37.5	47.5	27.5	32.5	12	12	33	19.5	22	12	M6 x 1.0	52	10	10	15	40	5.5	9 depth 7	41.5

ø32 to ø50

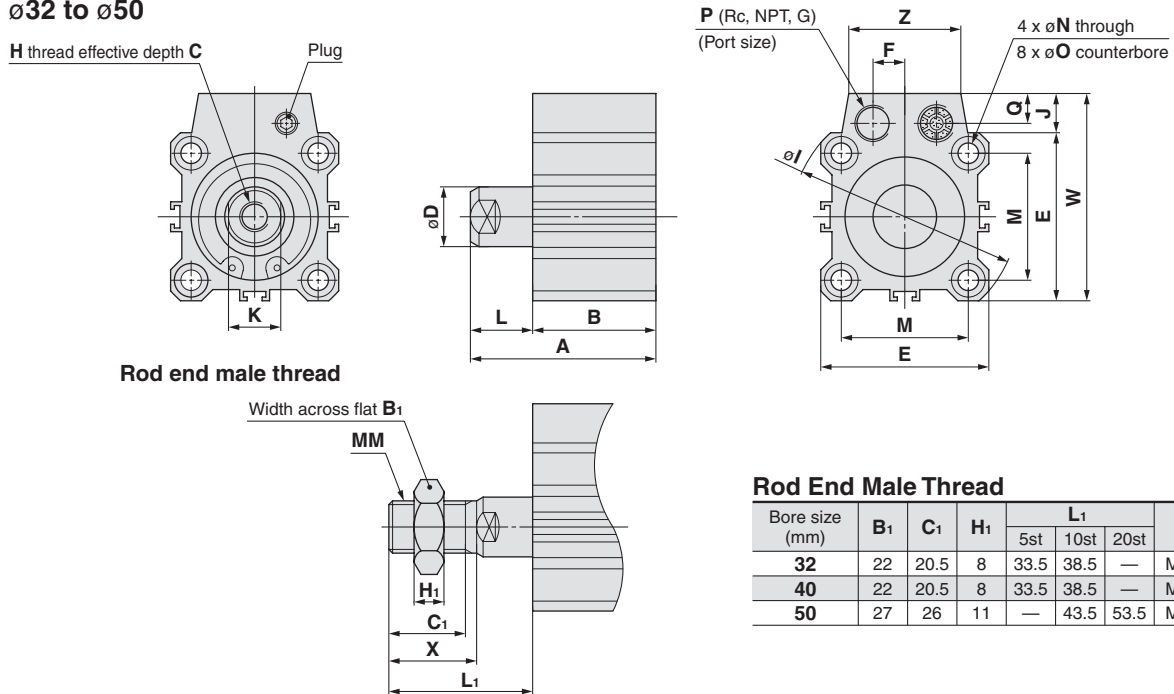

Rod End Male Thread (mm)

Bore size (mm)	B ₁	C ₁	H ₁	L ₁			MM	X
				5st	10st	20st		
32	22	20.5	8	33.5	38.5	—	M14 x 1.5	23.5
40	22	20.5	8	33.5	38.5	—	M14 x 1.5	23.5
50	27	26	11	—	43.5	53.5	M18 x 1.5	28.5

Standard

Bore size (mm)	A			B			C	D	E	F	H	I	J	K	L			M	N	O	P	Q	W	Z
	5st	10st	20st	5st	10st	20st									5st	10st	20st							
32	40	50	—	28	33	—	13	16	45	8.5	M8 x 1.25	60	10.5	14	12	17	—	34	5.5	9 depth 7	1/8	8	55.5	30
40	46.5	56.5	—	34.5	39.5	—	13	16	52	8.5	M8 x 1.25	69	10	14	12	17	—	40	5.5	9 depth 7	1/8	8	62	30
50	—	58.5	78.5	—	40.5	50.5	15	20	64	11	M10 x 1.5	86	13	17	—	18	28	50	6.6	11 depth 8	1/4	10	77	39

* For details about the rod end nut and accessory brackets, refer to page 178.

- Standard
- Single Acting
- Double Rod
- Axial Piping
- Water Resistant
- High Lateral Load
- End Lock
- Clean Series
- Copper/Fluorine free series
- Construction and Parts
- Warranty and Operating Instructions
- Mounting and Auto Switches
- Made to Order

ø12 to ø50 Spring Extend - With Auto Switch

ø12 to ø25

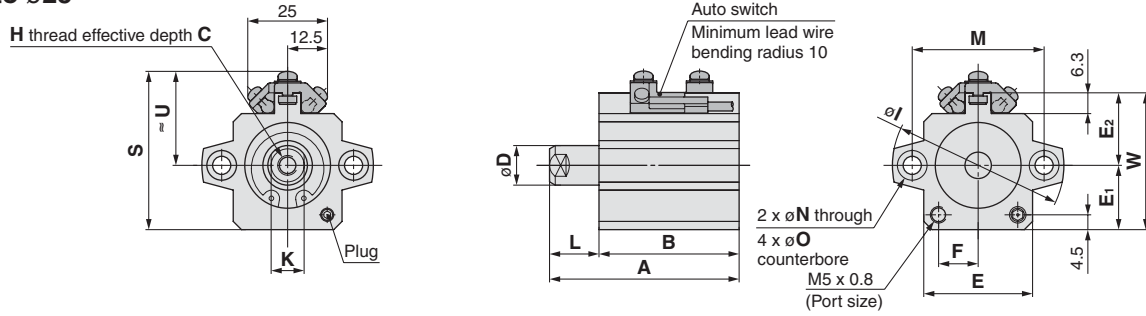

Rod end male thread

Width across flat B₁

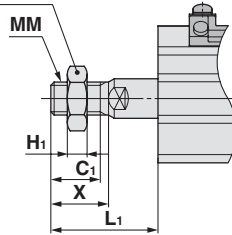

Rod End Male Thread

(mm)

Bore size (mm)	B ₁	C ₁	H ₁	L ₁		MM	X
				5st	10st		
12	8	9	4	19	24	M5 x 0.8	10.5
16	10	10	5	20.5	25.5	M6 x 1.0	12
20	13	12	5	23.5	28.5	M8 x 1.25	14
25	17	15	6	27.5	32.5	M10 x 1.25	17.5

Standard For auto switch proper mounting position and its mounting height, refer to pages 196 to 198.

(mm)

Bore size (mm)	A		B		C	D	E	E ₁	E ₂	F	H	I	K	L		M	N	O	S	U	W
	5st	10st	5st	10st										5st	10st						
12	45.9	55.9	37.4	42.4	6	6	23	13	14	7	M3 x 0.5	32	5	8.5	13.5	22	3.5	6.5 depth 3.5	33.5	20.5	27
16	44	54	35.5	40.5	8	8	26	15	17	8.5	M4 x 0.7	38	6	8.5	13.5	28	3.5	6.5 depth 3.5	38.5	23.5	32
20	46	56	36.5	41.5	7	10	30	17	19	10.5	M5 x 0.8	47	8	9.5	14.5	36	5.5	9 depth 7	42.5	25.5	36
25	47.5	57.5	37.5	42.5	12	12	33	19.5	22	12	M6 x 1.0	52	10	10	15	40	5.5	9 depth 7	48	28.5	41.5

ø32 to ø50

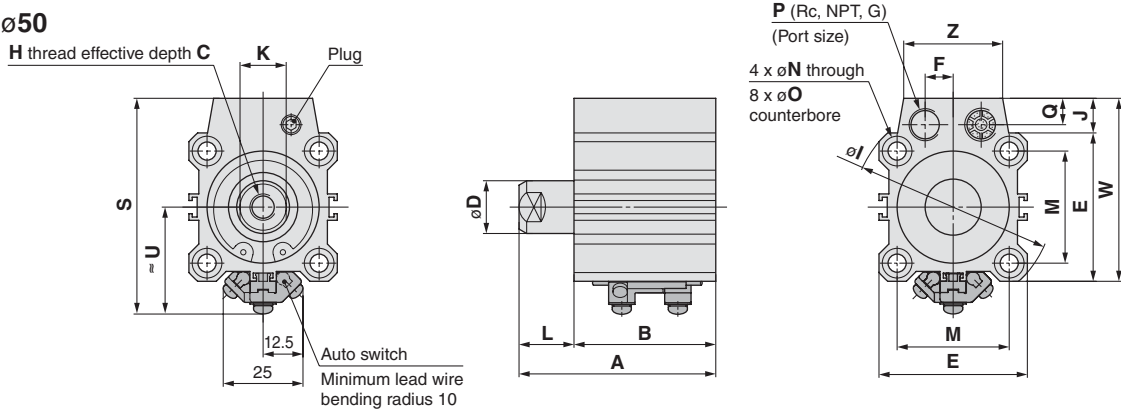

Rod end male thread

Width across flat B₁

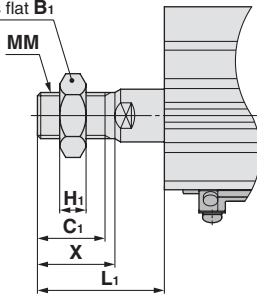

Rod End Male Thread

(mm)

Bore size (mm)	B ₁	C ₁	H ₁	L ₁			MM	X
				5st	10st	20st		
32	22	20.5	8	33.5	38.5	—	M14 x 1.5	23.5
40	22	20.5	8	33.5	38.5	—	M14 x 1.5	23.5
50	27	26	11	—	43.5	53.5	M18 x 1.5	28.5

Standard For auto switch proper mounting position and its mounting height, refer to pages 196 to 198.

(mm)

Bore size (mm)	A			B			C	D	E	F	H	I	J	K	L			M	N	O	P	Q	S	U	W	Z
	5st	10st	20st	5st	10st	20st									5st	10st	20st									
32	50	60	—	38	43	—	13	16	45	8.5	M8 x 1.25	60	10.5	14	12	17	—	34	5.5	9 depth 7	1/8	8	62	29	55.5	30
40	56.5	66.5	—	44.5	49.5	—	13	16	52	8.5	M8 x 1.25	69	10	14	12	17	—	40	5.5	9 depth 7	1/8	8	68.5	32.5	62	30
50	—	68.5	88.5	—	50.5	60.5	15	20	64	11	M10 x 1.5	86	13	17	—	18	28	50	6.6	11 depth 8	1/4	10	83.5	38.5	77	39

* For details about the rod end nut and accessory brackets, refer to page 178.

How to Order

C **D** **Q2** **B** **32** **□** **R** - **30** **D** **□** **Z** - **□**

Magnet

Nil	Without magnet
D	With magnet

Mounting

B	Through hole (std.)
A	Threaded
D	Clevis
L	Foot
G	Head flange
F	Rod flange

* Mounting brackets are shipped together, (but not assembled).
 * Cylinder mounting bolts are not included. Order them separately referring to "Mounting Bolt for C(D)Q2B" on pages 156 and 157.

Bore size

12	12 mm
16	16 mm
20	20 mm
25	25 mm
32	32 mm
40	40 mm
50	50 mm
63	63 mm
80	80 mm
100	100 mm

Port thread type

Nil	Rc
TN	NPT
TF	G
F	One Touch

Water Resistant Cylinder

R	NBR Seal
V	FKM Seal

Switch

M9	Solid state switch (see page 181 for details)
A9	Reed switch

New switch type
(required if ordering "D")

Nil	No magnet, ø12 to 25, and ø125 to 200
Z	ø12 to 100 with magnet, and ø32 to 100 w/o magnet

Body option

Nil	Standard (Rod end female thread)
-----	----------------------------------

Stroke standard (pneumatic)

Bore	Stroke standard (pneumatic)										Long stroke							
	5	10	15	20	25	30	35	40	45	50	75	100	125	150	175	200	250	300
12	●	●	●	●	●	●												
16	●	●	●	●	●	●												
20	●	●	●	●	●	●	●	●	●									
25	●	●	●	●	●	●	●	●	●	●								
32	●	●	●	●	●	●	●	●	●	●	●	●	●	●	●	●	●	●
40	●	●	●	●	●	●	●	●	●	●	●	●	●	●	●	●	●	●
50		●	●	●	●	●	●	●	●	●	●	●	●	●	●	●	●	●
63		●	●	●	●	●	●	●	●	●	●	●	●	●	●	●	●	●
80		●	●	●	●	●	●	●	●	●	●	●	●	●	●	●	●	●
100		●	●	●	●	●	●	●	●	●	●	●	●	●	●	●	●	●

- Standard
- Single Acting
- Double Rod
- Axial Piping
- Water Resistant
- High Lateral Load
- End Lock
- Clean Series
- Copper/Fluorine free series
- Construction and Parts
- Warranty and Operating Instructions
- Mounting and Auto Switches
- Made to Order



JIS Symbol
Double acting,
Single rod

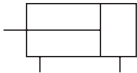

Specifications

Bore size (mm)	20	25	32	40	50	63	80	100
Action	Double acting, Single rod							
Fluid	Air							
Proof pressure	218 psi (1.5 MPa)							
Maximum operating pressure	145 psi (1.0 MPa)							
Minimum operating pressure	11.6 psi (0.08 MPa)							
Ambient and fluid temperature	Without auto switch: -10 to 70°C (No freezing) With auto switch: -10 to 60°C (No freezing)							
Lubrication	Not required (Non-lube)							
Piston speed	50 to 500 mm/s							
Allowable kinetic energy (J)	0.055	0.09	0.15	0.26	0.46	0.77	1.36	2.27
Stroke length tolerance	+1.0 mm 0							

Standard Strokes

Bore size	Standard stroke (mm)
20, 25	5, 10, 15, 20, 25, 30, 35, 40, 45, 50
32, 40	5, 10, 15, 20, 25, 30, 35, 40, 45, 50, 75, 100
50, 63, 80, 100	10, 15, 20, 25, 30, 35, 40, 45, 50, 75, 100

Manufacture of Intermediate Strokes

Type	A spacer is installed in the standard stroke body.	
Part no.	Refer to "How to Order" for the standard model number. (P. 91)	
Description	Strokes in 1 mm intervals are available by installing a spacer in the standard stroke cylinder.	
Stroke range	Bore size	Stroke range
	20, 25	1 to 49
	32 to 100	1 to 99
Example	Part no.: CQ2B50R-57DZ CQ2B50R-75DZ with 18 mm width spacer inside The B dimension is 115.5 mm.	

Type

Bore size (mm)		20	25	32	40	50	63	80	100	
Pneumatic	Mounting	Through-hole (Standard)	●	●	●	●	●	●	●	
		Both ends tapped	—	—	—	●	●	●	●	
	Built-in magnet		●	●	●	●	●	●	●	
	Piping	Pipe thread	—	M5 x 0.8	M5 x 0.8	M5 x 0.8 <small>Note</small> Rc1/8	Rc1/8	Rc1/4	Rc1/4	Rc3/8
			TN	—	—	NPT1/8	NPT1/8	NPT1/4	NPT1/4	NPT3/8
			TF	—	—	G1/8	G1/8	G1/4	G1/4	G3/8
Rod end male thread		●	●	●	●	●	●	●		

Note) ø32 without auto switch: M5 x 0.8 is used for 5 mm stroke/piping dimension.
Thus, do not enter a symbol for the port thread type.

Conversions

°F = 1.8°C + 32 1 J = 0.738 ft-lb
1 MPa = 145 psi 1 mm = 0.039 in

Theoretical Output



Bore size (mm)	Operating direction	Operating pressure (MPa)		
		0.3	0.5	0.7
20	IN	71	118	165
	OUT	94	157	220
25	IN	113	189	264
	OUT	147	245	344
32	IN	181	302	422
	OUT	241	402	563
40	IN	317	528	739
	OUT	377	628	880
50	IN	495	825	1150
	OUT	589	982	1370
63	IN	841	1400	1960
	OUT	935	1560	2180
80	IN	1360	2270	3170
	OUT	1510	2510	3520
100	IN	2140	3570	5000
	OUT	2360	3930	5500

Weight

Without Auto Switch

Stroke Bore size	(g)											
	5	10	15	20	25	30	35	40	45	50	75	100
ø20	112	126	141	155	169	184	198	212	227	241	—	—
ø25	149	165	182	197	213	229	245	261	277	293	—	—
ø32	203	224	246	267	288	309	330	352	373	394	544	650
ø40	220	241	263	284	306	327	349	371	392	414	568	680
ø50	—	378	411	444	476	509	542	575	608	641	879	1051
ø63	—	547	585	623	662	700	738	776	814	852	1125	1321
ø80	—	973	1034	1094	1154	1214	1275	1335	1395	1455	1873	2169
ø100	—	1703	1783	1863	1944	2024	2104	2185	2265	2345	2915	3323

Additional Weight

Bore size (mm)		20	25	32	40	50	63	80	100
Both ends tapped		—	—	—	6	6	19	45	45
Rod end male thread	Male thread	6	12	26	27	53	53	120	175
	Nut	4	8	17	17	32	32	49	116
Foot (Incl. mounting bolts)		—	—	—	154	243	320	690	1057
Rod flange (Incl. mounting bolts)		—	—	—	214	373	559	1056	1365
Head flange (Incl. mounting bolts)		—	—	—	198	348	534	1017	1309
Double clevis (Incl. pin, retaining rings, bolts)		—	—	—	196	393	554	1109	1887

Calculation: (Example) **CQ2D40R-20DMZ**

- Basic weight: CQ2B40R-20DZ 284 g
 - Additional weight: Both ends tapped 6 g
 - Rod end male thread 44 g
 - Double clevis 196 g
- 530 g

1g = 0.0353 oz Add each weight of auto switches
1kg = 2.2046 lb when auto switches are mounted.

Standard

Single Acting

Double Rod

Axial Piping

Water Resistant

High Lateral Load

End Lock

Clean Series

Copper/Fluorine free series

Construction and Parts

Warranty and Operating Instructions

Mounting and Auto Switches

Made to Order



Weight

Stroke Bore size	(g)											
	5	10	15	20	25	30	35	40	45	50	75	100
ø20	130	142	155	167	179	191	204	216	228	240	—	—
ø25	182	197	213	228	244	259	275	290	306	320	—	—
ø32	263	284	305	327	348	369	390	412	433	454	561	668
ø40	293	315	336	358	379	401	422	444	465	487	598	710
ø50	—	489	522	555	588	620	653	687	720	753	925	1097
ø63	—	700	738	776	814	852	890	928	966	1004	1201	1397
ø80	—	1219	1279	1340	1400	1460	1520	1581	1641	1701	1998	2295
ø100	—	2061	2142	2222	2302	2383	2463	2543	2624	2704	3112	3520

Additional Weight

		20	25	32	40	50	63	80	100
Both ends tapped		—	—	—	6	6	19	45	45
Rod end male thread	Male thread	6	12	26	27	53	53	120	175
	Nut	4	8	17	17	32	32	49	116
Foot (Including mounting bolts)		—	—	—	154	243	320	690	1057
Rod flange (Including mounting bolts)		—	—	—	214	373	559	1056	1365
Head flange (Including mounting bolts)		—	—	—	198	348	534	1017	1309
Double clevis (Including pin, retaining rings, bolts)		—	—	—	196	393	554	1109	1887

Calculation: (Example) **CDQ2D40R-20DMZ**

- Basic weight: CDQ2B40R-20DZ.....358 g
- Additional weight: Both ends tapped..... 6 g
- Rod end male thread... 44 g
- Double clevis.....196 g
- 604 g

Add each weight of auto switches when auto switches are mounted.

1g = 0.0353 oz
1kg = 2.2046 lb

ø20 to ø25 - Without Auto Switch

Standard (Through-hole): CQ2B

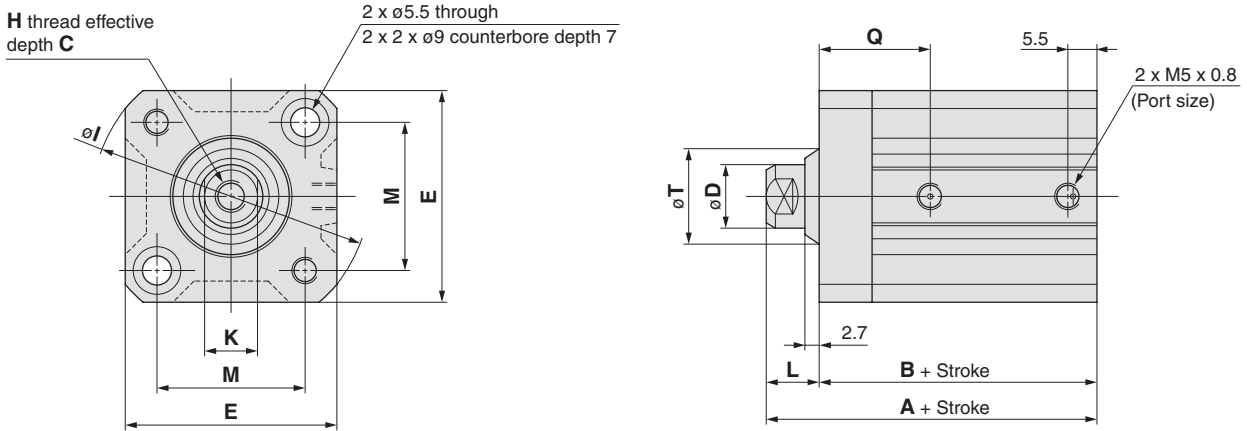

Rod end male thread

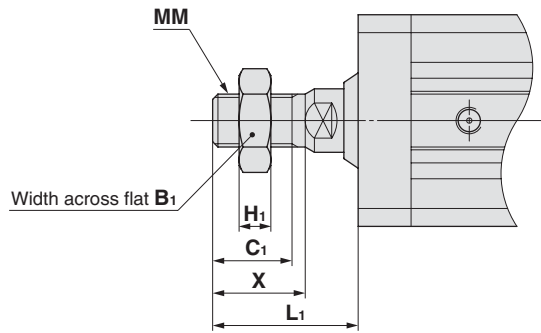

Rod End Male Thread

Bore size (mm)	B ₁	C ₁	H ₁	L ₁	MM	X
20	13	12	5	23.5	M8 x 1.25	14
25	17	15	6	27.5	M10 x 1.25	17.5

Standard

Bore size (mm)	Stroke range (mm)	A	B	C	D	E	H	I	K	L	M	Q	T
20	5 to 50	39	29.5	7	10	36	M5 x 0.8	47	8	9.5	25.5	19	16.1
25	5 to 50	42.5	32.5	12	12	40	M6 x 1.0	52	10	10	28	21	18.1

* For details about the rod end nut and accessory brackets, refer to page 178.

* Refer to page 92 for the calculation on the longitudinal dimension of intermediate strokes.

- Standard
- Single Acting
- Double Rod
- Axial Piping
- Water Resistant
- High Lateral Load
- End Lock
- Clean Series
- Copper/Fluorine free series
- Construction and Parts
- Warranty and Operating Instructions
- Mounting and Auto Switches
- Made to Order

ø20 to ø25 - With Auto Switch

Standard (Through-hole): CDQ2B

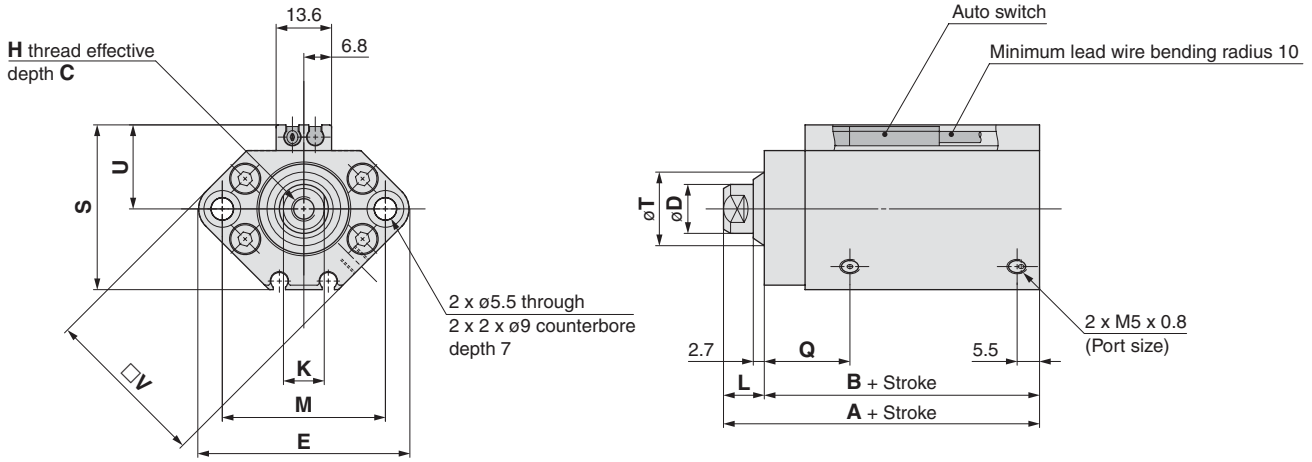

Rod end male thread

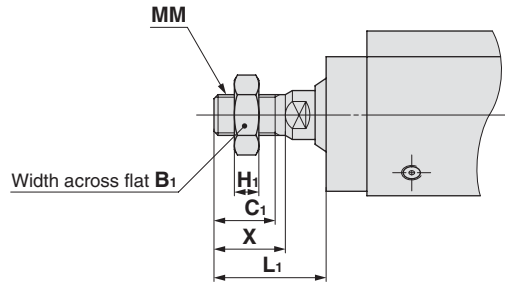

Rod End Male Thread (mm)

Bore size (mm)	B ₁	C ₁	H ₁	L ₁	MM	X
20	13	12	5	23.5	M8 x 1.25	14
25	17	15	6	27.5	M10 x 1.25	17.5

Standard For auto switch proper mounting position and its mounting height, refer to pages 188 to 194. (mm)

Bore size (mm)	Stroke range (mm)	A	B	C	D	E	H	K	L	M	Q	S	T	U	V
20	5 to 50	51	41.5	7	10	47	M5 x 0.8	8	9.5	36	20.5	35.5	16.1	18	36
25	5 to 50	52.5	42.5	12	12	52	M6 x 1.0	10	10	40	21	40.5	18.1	21	40

* For details about the rod end nut and accessory brackets, refer to page 178.
* Refer to page 92 for the calculation on the longitudinal dimension of intermediate strokes.

Ø32 - With Auto Switch

(Without auto switches, only the A, B dimensions will be changed. Refer to the dimension table.)

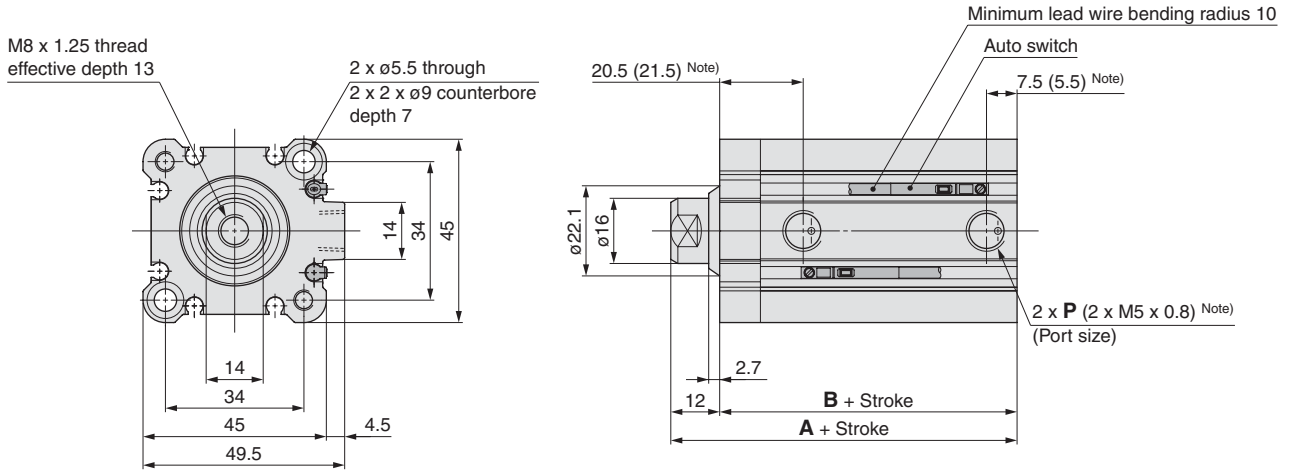

Rod end male thread

Note (): Without auto switch, 5 mm strokes

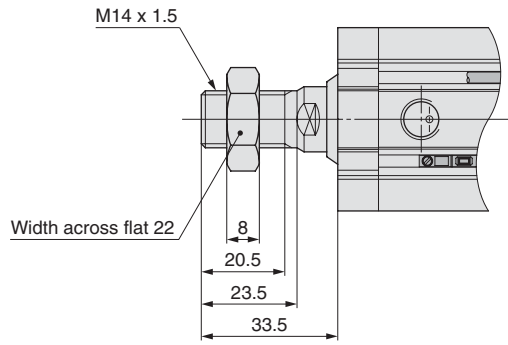

Stroke range (mm)	Without auto switch		With auto switch		P		
	A	B	A	B	—	TN	TF
5 to 50	45	33	55	43	Rc1/8	NPT1/8	G1/8
75, 100	55	43					

* For details about the rod end nut and accessory brackets, refer to page 178.
* Refer to page 92 for the calculation on the longitudinal dimension of intermediate strokes.

- Standard
- Single Acting
- Double Rod
- Axial Piping
- Water Resistant**
- High Lateral Load
- End Lock
- Clean Series
- Copper/Fluorine free series
- Construction and Parts
- Warranty and Operating Instructions
- Mounting and Auto Switches
- Made to Order

ø40 to ø50 - With Auto Switch

(Without auto switches, only the A, B dimensions will be changed. Refer to the dimension table.)

**Standard (Through-hole):
CQ2B/CDQ2B**

Both ends tapped: CQ2A/CDQ2A

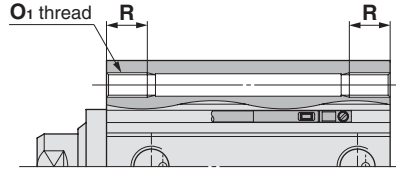

Both Ends Tapped (mm)

Bore size (mm)	O ₁	R
40	M6 x 1.0	10
50	M8 x 1.25	14

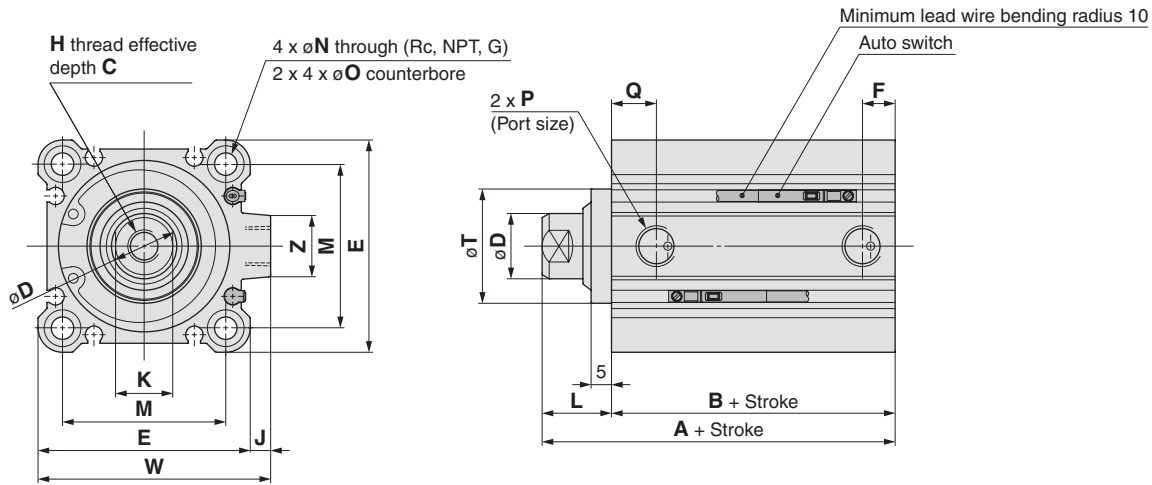

Rod end male thread

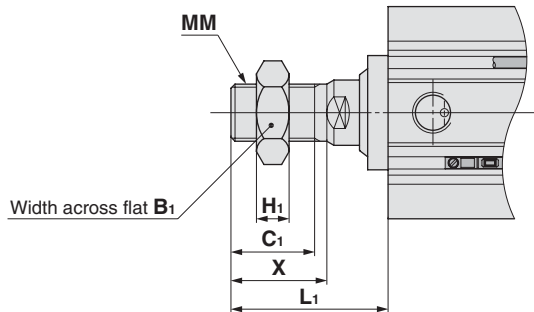

Rod End Male Thread (mm)

Bore size (mm)	B ₁	C ₁	H ₁	L ₁	MM	X
40	22	20.5	8	38.5	M14 x 1.5	23.5
50	27	26	11	43.5	M18 x 1.5	28.5

Standard For auto switch proper mounting position and its mounting height, refer to pages 188 to 194.

(mm)

Bore size (mm)	Stroke range (mm)	Without auto switch		With auto switch		C	D	E	F	H	J	K	L	M	N	O	P	Q	T	W	Z
		A	B	A	B																
40	5 to 50	46.5	29.5	56.5	39.5	13	16	52	8	M8 x 1.25	5	14	17	40	5.5	9 depth 7	1/8	11	28	57	15
	75, 100	56.5	39.5																		
50	10 to 50	48.5	30.5	58.5	40.5	15	20	64	10.5	M10 x 1.5	7	17	18	50	6.6	11 depth 8	1/4	10.5	35	71	19
	75, 100	58.5	40.5																		

Note 1) For details about the rod end nut and accessory brackets, refer to page 178.

Note 2) Refer to page 92 for the calculation on the longitudinal dimension of intermediate strokes.

Foot: CQ2L/CDQ2L

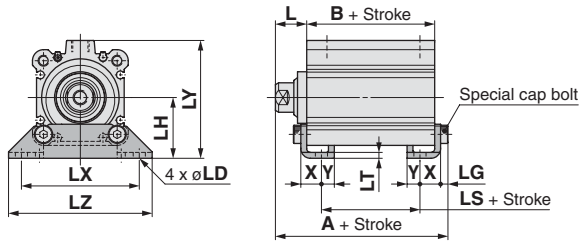

Rod end male thread

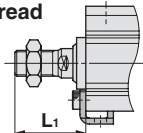

Rod flange: CQ2F/CDQ2F

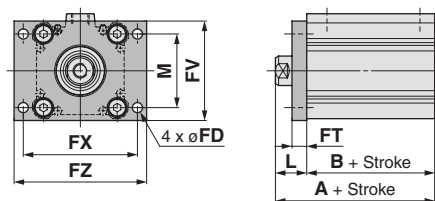

Rod end male thread

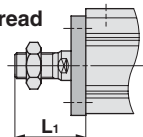

Head flange: CQ2G/CDQ2G

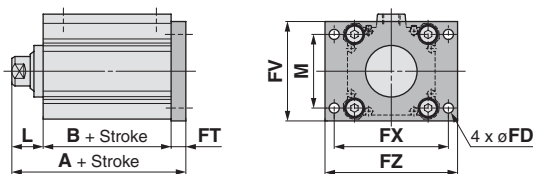

Rod end male thread

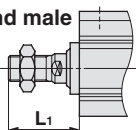

Double clevis: CQ2D/CDQ2D

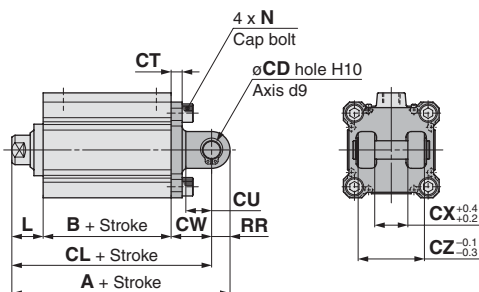

Rod end male thread

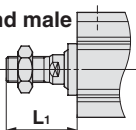

Foot

Bore size (mm)	Stroke range (mm)	Without auto switch			With auto switch			L	L ₁	LD
		A	B	LS	A	B	LS			
40	5 to 50	53.7	29.5	13.5	63.7	39.5	23.5	17	38.5	6.6
	75, 100	63.7	39.5	23.5						
50	10 to 50	56.7	30.5	7.5	66.7	40.5	17.5	18	43.5	9
	75, 100	66.7	40.5	17.5						

Bore size (mm)	LG	LH	LT	LX	LY	LZ	X	Y
40	4	33	3.2	64	64	78	11.2	7
50	5	39	3.2	79	78	95	14.7	8

Foot bracket material: Carbon steel
Surface treatment: Nickel plated

Rod Flange

Bore size (mm)	Stroke range (mm)	Without auto switch		With auto switch		FD	FT	FV	FX	FZ
		A	B	A	B					
40	5 to 50	46.5	29.5	56.5	39.5	5.5	8	54	62	72
	75, 100	56.5	39.5							
50	10 to 50	48.5	30.5	58.5	40.5	6.6	9	67	76	89
	75, 100	58.5	40.5							

Bore size (mm)	L	L ₁	M
40	17	38.5	40
50	18	43.5	50

Flange bracket material: Carbon steel
Surface treatment: Nickel plated

Head Flange

Bore size (mm)	Stroke range (mm)	Without auto switch		With auto switch	
		A	A	A	A
40	5 to 50	54.5		64.5	
	75, 100	64.5			
50	10 to 50	57.5		67.5	
	75, 100	67.5			

* The dimensions except A are the same as those of the rod flange.

Flange bracket material: Carbon steel
Surface treatment: Nickel plated

Double Clevis

Bore size (mm)	Stroke range (mm)	Without auto switch			With auto switch			CD	CT	CU
		A	B	CL	A	B	CL			
40	5 to 50	78.5	29.5	68.5	88.5	39.5	78.5	10	6	14
	75, 100	88.5	39.5	78.5						
50	10 to 50	90.5	30.5	76.5	100.5	40.5	86.5	14	7	20
	75, 100	100.5	40.5	86.5						

Bore size (mm)	CW	CX	CZ	L	L ₁	N	RR
40	22	18	36	17	38.5	M6 x 1.0	10
50	28	22	44	18	43.5	M8 x 1.25	14

Double clevis bracket material: Cast iron
Surface treatment: Painted

* For details about the rod end nut and accessory brackets, refer to page 178.
* Double clevis pin and retaining rings are included.

Standard

Single Acting

Double Rod

Axial Piping

Water Resistant

High Lateral Load

End Lock

Clean Series

Copper/Fluorine free series

Construction and Parts

Warranty and Operating Instructions

Mounting and Auto Switches

Made to Order

Series CQ2

Double Acting, Single Rod
Dimensions - Water Resistant

ø63 to ø100 - With Auto Switch

(Without auto switches, only the A, B dimensions will be changed. Refer to the dimension table.)

Both ends tapped: CQ2A/CDQ2A

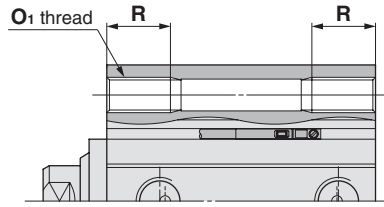

Both Ends Tapped (mm)

Bore size (mm)	O ₁	R
63	M10 x 1.5	18
80	M12 x 1.75	22
100	M12 x 1.75	22

Standard (Through-hole): CQ2B/CDQ2B

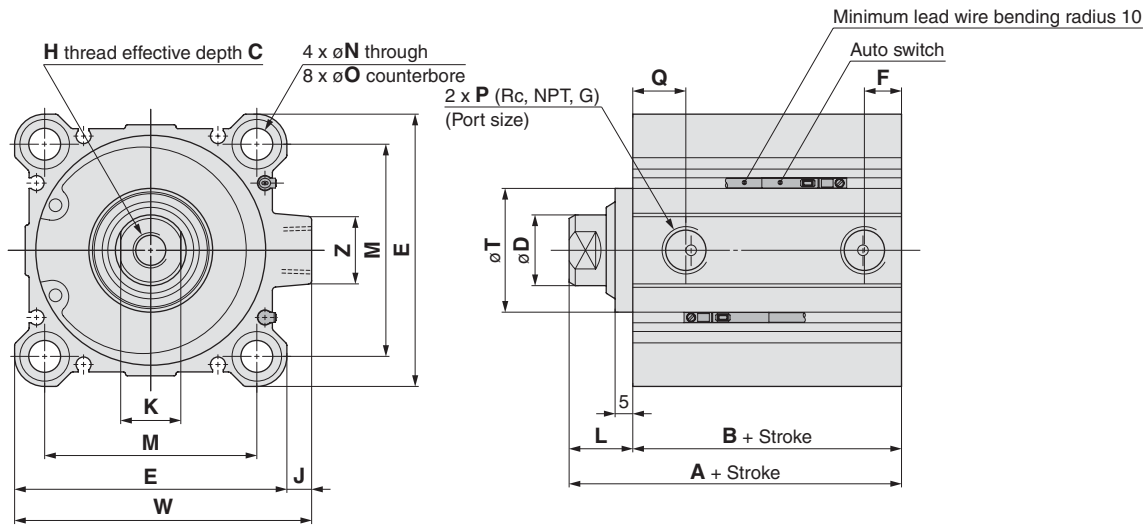

Rod end male thread

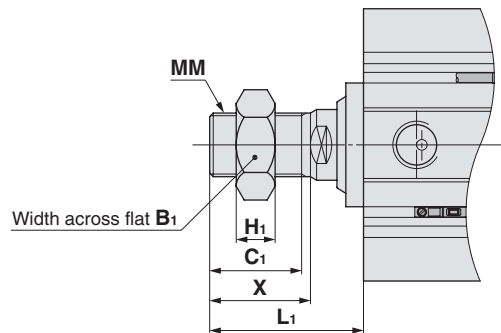

Rod End Male Thread (mm)

Bore size (mm)	B ₁	C ₁	H ₁	L ₁	MM	X
63	27	26	11	43.5	M18 x 1.5	28.5
80	32	32.5	13	53.5	M22 x 1.5	35.5
100	41	32.5	16	53.5	M26 x 1.5	35.5

Standard For auto switch proper mounting position and its mounting height, refer to pages 188 to 194.

(mm)

Bore size (mm)	Stroke range (mm)	Without auto switch		With auto switch		C	D	E	F	H	J	K	L	M	N	O	P	Q	T
		A	B	A	B														
63	10 to 50	54	36	64	46	15	20	77	10.5	M10 x 1.5	7	17	18	60	9	14 depth 10.5	1/4	15	35
	75, 100	64	46																
80	10 to 50	63.5	43.5	73.5	53.5	21	25	98	12.5	M16 x 2.0	6	22	20	77	11	17.5 depth 13.5	3/8	16	43
	75, 100	73.5	53.5																
100	10 to 50	75	53	85	63	27	30	117	13	M20 x 2.5	6.5	27	22	94	11	17.5 depth 13.5	3/8	23	59
	75, 100	85	63																

(mm)

Bore size (mm)	W	Z
63	84	19
80	104	25
100	123.5	25

* For details about the rod end nut and accessory brackets, refer to page 178.

Note) Refer to page 92 for the calculation on the longitudinal dimension of intermediate strokes.

Foot: CQ2L/CDQ2L

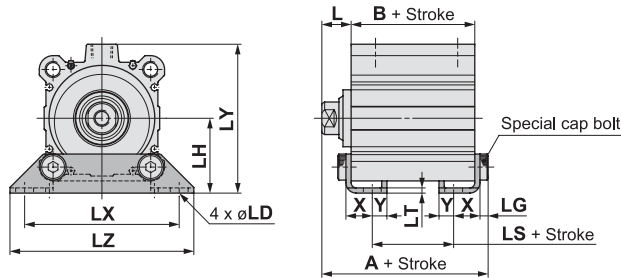

Rod end male thread

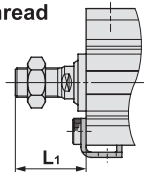

Head flange: CQ2G/CDQ2G

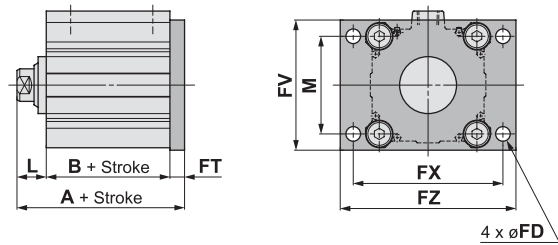

Rod end male thread

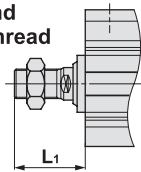

Rod flange: CQ2F/CDQ2F

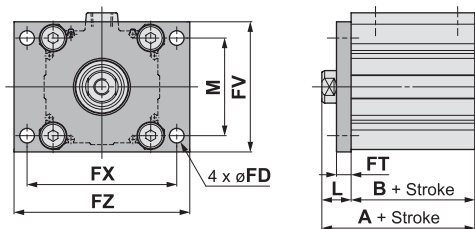

Rod end male thread

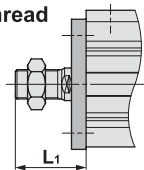

Double clevis: CQ2D/CDQ2D

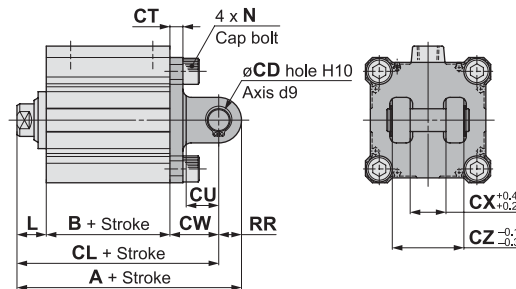

Rod end male thread

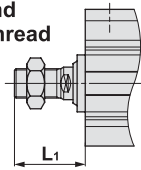

Foot (mm)

Bore size (mm)	Stroke range (mm)	Without auto switch			With auto switch			L	L ₁	LD	LG	LH	LT
		A	B	LS	A	B	LS						
63	10 to 50	62.2	36	10	72.2	46	20	18	43.5	11	5	46	3.2
	75, 100	72.2	46	20									
80	10 to 50	75	43.5	13.5	85	53.5	23.5	20	53.5	13	7	59	4.5
	75, 100	85	53.5	23.5									
100	10 to 50	88	53	19	98	63	29	22	53.5	13	7	71	6
	75, 100	98	63	29									

Foot bracket material: Carbon steel
Surface treatment: Nickel plated

Bore size (mm)	Stroke range (mm)	LX	LY	LZ	X	Y
80	10 to 50	118	114	140	19.5	11
	75, 100					
100	10 to 50	137	136	162	23	12.5
	75, 100					

Rod Flange (mm)

Bore size (mm)	Stroke range (mm)	Without auto switch			With auto switch			FD	FT	FV	FX	FZ	L	L ₁	M
		A	B	LS	A	B	LS								
63	10 to 50	54	36		64	46	9	9	80	92	108	18	43.5	60	
	75, 100	64	46												
80	10 to 50	63.5	43.5		73.5	53.5	11	11	99	116	134	20	53.5	77	
	75, 100	73.5	53.5												
100	10 to 50	75	53		85	63	11	11	117	136	154	22	53.5	94	
	75, 100	85	63												

Flange bracket material: Carbon steel
Surface treatment: Nickel plated

Head Flange (mm)

Bore size (mm)	Stroke range (mm)	Without auto switch		With auto switch	
		A	B	A	B
63	10 to 50	63		73	
	75, 100	73			
80	10 to 50	74.5		84.5	
	75, 100	84.5			
100	10 to 50	86		96	
	75, 100	96			

(*The dimensions except A are the same as those of the rod flange.)

Flange bracket material: Carbon steel
Surface treatment: Nickel plated

Double Clevis (mm)

Bore size (mm)	Stroke range (mm)	Without auto switch			With auto switch			CD	CT	CU	CW	CX
		A	B	CL	A	B	CL					
63	10 to 50	98	36	84	108	46	94	14	8	20	30	22
	75, 100	108	46	94								
80	10 to 50	119.5	43.5	101.5	129.5	53.5	111.5	18	10	27	38	28
	75, 100	129.5	53.5	111.5								
100	10 to 50	142	53	120	152	63	130	22	13	31	45	32
	75, 100	152	63	130								

Bore size (mm)	Stroke range (mm)	CZ	L	L ₁	N	RR
80	10 to 50	56	20	53.5	M12 x 1.75	18
	75, 100					
100	10 to 50	64	22	53.5	M12 x 1.75	22
	75, 100					

Double clevis bracket material: Cast iron
Surface treatment: Painted

* For details about the rod end nut and accessory brackets, refer to page 178.
* Double clevis pin and retaining rings are included.

- Standard
- Single Acting
- Double Rod
- Axial Piping
- Water Resistant
- High Lateral Load
- End Lock
- Clean Series
- Copper/Fluorine free series
- Construction and Parts
- Warranty and Operating Instructions
- Mounting and Auto Switches
- Made to Order

How to Order

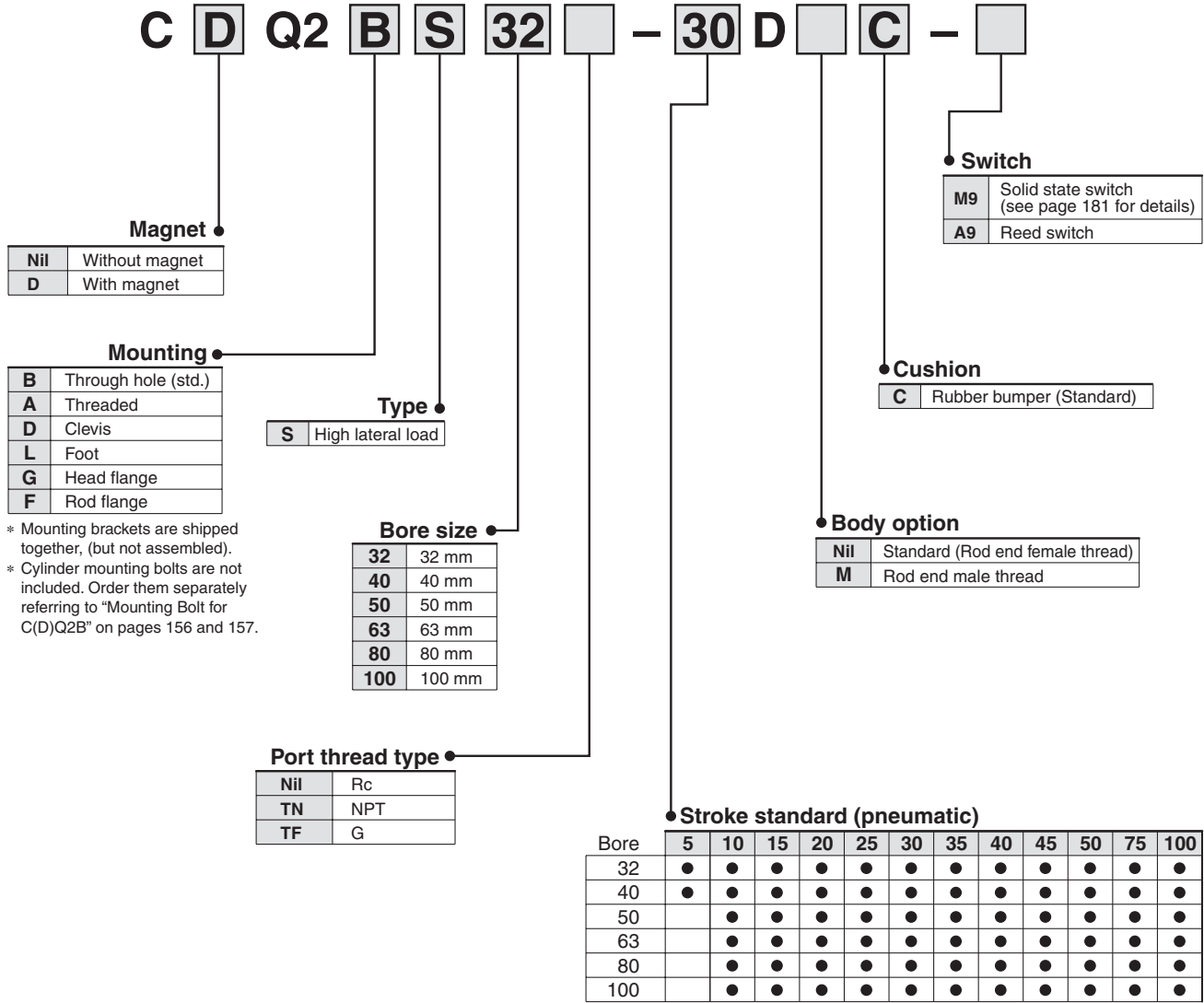

* Mounting brackets are shipped together, (but not assembled).
 * Cylinder mounting bolts are not included. Order them separately referring to "Mounting Bolt for C(D)Q2B" on pages 156 and 157.

- Standard
- Single Acting
- Double Rod
- Axial Piping
- Water Resistant
- High Lateral Load
- End Lock
- Clean Series
- Copper/Fluorine free series
- Construction and Parts
- Warranty and Operating Instructions
- Mounting and Auto Switches
- Made to Order

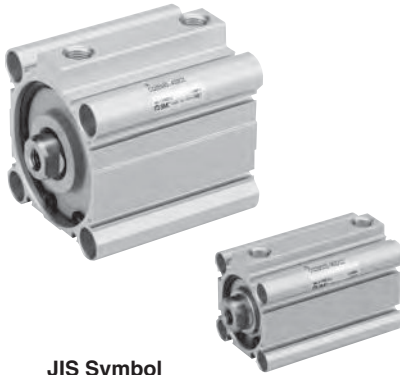

JIS Symbol
Double acting,
Single rod

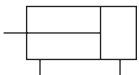

Specifications

Bore size (mm)	32	40	50	63	80	100
Action	Double acting, Single rod					
Fluid	Air					
Proof pressure	218 psi (1.5 MPa)					
Maximum operating pressure	145 psi (1.0 MPa)					
Minimum operating pressure	7.3 psi (0.05 MPa)					
Ambient and fluid temperature	Without auto switch: -10 to 70°C (No freezing) With auto switch: -10 to 60°C (No freezing)					
Lubrication	Not required (Non-lube)					
Piston speed	50 to 500 mm/s					
Allowable kinetic energy (J)	0.29	0.52	0.91	1.54	2.71	4.54
Stroke length tolerance	+1.0 mm (Note) 0					

Note) Stroke length tolerance does not include the amount of bumper change.

Standard Strokes

Bore size	Standard stroke (mm)
32, 40	5, 10, 15, 20, 25, 30, 35, 40, 45, 50, 75, 100
50, 63, 80, 100	10, 15, 20, 25, 30, 35, 40, 45, 50, 75, 100

Manufacture of Intermediate Strokes

Type	A spacer is installed in standard stroke body.	Exclusive body (-XB10)		
Part no.	Refer to "How to Order" for the standard model number. (P. 103)	Suffix "-XB10" to the end of standard model number. (P. 103)		
Description	Strokes in 1 mm intervals are available by installing a spacer in the standard stroke cylinder.	Strokes in 1 mm intervals are available by using an exclusive body with the specified stroke.		
Stroke range	Bore size	Stroke range	Bore size	Stroke range
	32 to 100	1 to 99	32, 40 50 to 100	6 to 99 11 to 99
Example	Part no.: CQ2BS50-57DCZ CQ2BS50-75DCZ with 18 mm width spacer inside The B dimension is 125.5 mm.	Part no.: CQ2BS50-57DCZ-XB10 Makes 57 stroke tube. The B dimension is 107.5 mm.		

- In the case of exclusive body type with $\phi 32$ to $\phi 100$ (-XB10) with the stroke length exceeding 50 mm, reference values of the longitudinal dimension will be changed.
- Calculate length dimensions by deducting from those of 75 or 100 mm stroke models.

Type

		Bore size (mm)						
		32	40	50	63	80	100	
Pneumatic	Mounting	Through-hole (Standard)	●	●	●	●	●	●
		Both ends tapped	●	●	●	●	●	●
	Built-in magnet		●	●	●	●	●	●
	Piping	Pipe thread	Rc1/8	Rc1/8	Rc1/4	Rc1/4	Rc3/8	Rc3/8
			NPT1/8	NPT1/8	NPT1/4	NPT1/4	NPT3/8	NPT3/8
			G1/8	G1/8	G1/4	G1/4	G3/8	G3/8
	Rod end male thread		●	●	●	●	●	●
	With rubber bumper (Std.)		●	●	●	●	●	●
With boss on head end		●	●	●	●	●	●	

Refer to pages 188 to 194 for the specifications of cylinders with auto switches.

- Auto switch proper mounting position (detection at stroke end) and its mounting height
- Minimum stroke for auto switch mounting
- Operating range
- Auto switch mounting brackets/Part no.

Conversions

$$\begin{aligned} ^\circ\text{F} &= 1.8^\circ\text{C} + 32 & 1 \text{ J} &= 0.738 \text{ ft-lb} \\ 1 \text{ MPa} &= 145 \text{ psi} & 1 \text{ mm} &= 0.039 \text{ in} \end{aligned}$$

Allowable Lateral Load at Rod End

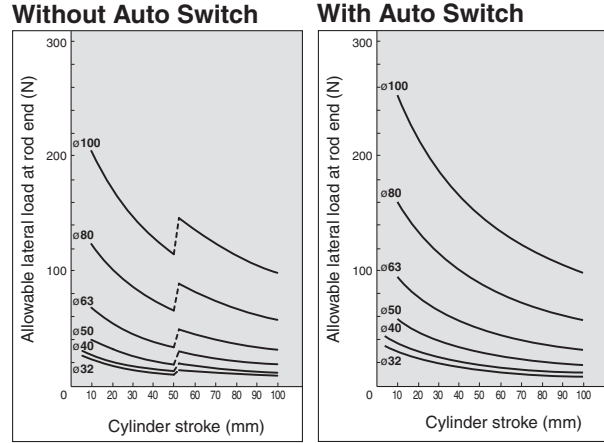

Theoretical Output



Bore size (mm)	Operating direction	Operating pressure (MPa)		
		0.3	0.5	0.7
32	IN	181	302	422
	OUT	241	402	563
40	IN	317	528	739
	OUT	377	628	880
50	IN	495	825	1155
	OUT	589	982	1374
63	IN	841	1402	1962
	OUT	935	1559	2182
80	IN	1361	2268	3175
	OUT	1508	2513	3519
100	IN	2144	3574	5003
	OUT	2356	3927	5498

Weight

Bore size (mm)	Cylinder stroke (mm)											
	5	10	15	20	25	30	35	40	45	50	75	100
32	134	154	174	193	213	233	252	272	291	311	457	556
40	211	232	254	275	297	318	340	361	383	404	577	689
50	—	369	402	435	467	500	533	566	598	632	902	1073
63	—	557	595	633	671	709	747	786	824	862	1189	1386
80	—	983	1043	1104	1164	1224	1284	1345	1405	1465	1985	2281
100	—	1711	1792	1872	1952	2033	2113	2194	2274	2354	3086	3494

Additional Weight

Bore size (mm)		32	40	50	63	80	100
Both ends tapped		6	6	6	19	45	45
Rod end male thread	Male thread	26	27	53	53	120	175
	Nut	17	17	32	32	49	116
Foot (Including mounting bolts)		142	154	243	320	690	1057
Rod flange (Including mounting bolts)		180	214	373	559	1056	1365
Head flange (Including mounting bolts)		165	198	348	534	1017	1309
Double clevis (Including pin, retaining rings, bolts)		151	196	393	554	1109	1887

Calculation: (Example) **CQ2DS32-20DCMZ**

- Basic weight: CQ2BS32-20DCZ..... 193 g
 - Additional weight: Both ends tapped..... 6 g
 - Rod end male thread..... 43 g
 - Double clevis.....151 g
- 393 g

Conversions

1 g = 0.0353 oz 1 mm = 0.039 in
1 kg = 2.2046 lb 1N = 0.2248 lbf

Standard
Single Acting
Double Rod
Axial Piping
Water Resistant
High Lateral Load
End Lock
Clean Series
Copper/Fluorine free series
Construction and Parts
Warranty and Operating Instructions
Mounting and Auto Switches
Made to Order

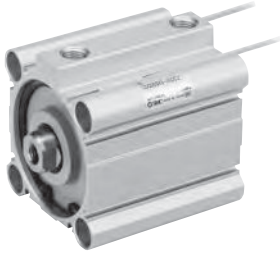

Refer to the below pages for further information on auto switches.

Auto switch proper mounting position and its mounting height	P.188 to 194
Minimum stroke for auto switch mounting	
Operating range	
Auto switch mounting brackets/Part no.	

Weight

Weight

(g)

Bore size (mm)	Cylinder stroke (mm)											
	5	10	15	20	25	30	35	40	45	50	75	100
32	191	211	230	250	270	289	309	329	348	368	468	567
40	284	305	327	348	369	391	412	434	455	477	589	701
50	—	480	513	546	579	611	644	677	710	743	915	1087
63	—	710	748	787	825	863	901	939	977	1015	1211	1408
80	—	1229	1289	1350	1410	1470	1530	1591	1651	1711	2008	2305
100	—	2070	2150	2231	2311	2391	2472	2552	2633	2713	3121	3529

Additional Weight

(g)

Bore size (mm)	32	40	50	63	80	100
Both ends tapped	6	6	6	19	45	45
Rod end male thread	Male thread	26	27	53	53	120
	Nut	17	17	32	32	49
Foot (Including mounting bolts)	142	154	243	320	690	1057
Rod flange (Including mounting bolts)	180	214	373	559	1056	1365
Head flange (Including mounting bolts)	165	198	348	534	1017	1309
Double clevis (Including pin, retaining rings, bolts)	151	196	393	554	1109	1887

Calculation: (Example) **CDQ2DS32-20DCMZ**

- Basic weight: CDQ2BS32-20DCZ 193 g
- Additional weight: Both ends tapped 6 g
- Rod end male thread 43 g
- Double clevis 151 g
- 393 g

1g = 0.0353 oz
1kg = 2.2046 lb
1mm = 0.039 in

Add each weight of auto switches when auto switches are mounted.

ø32 to ø50 - With Auto Switch

(Without auto switches, only the A, B dimensions will be changed.
Refer to the dimension table.)

Standard (Through-hole): CQ2BS/CDQ2BS

Both ends tapped: CQ2AS/CDQ2AS

CDQ2AS

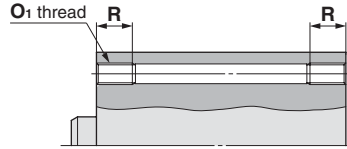

Both Ends Tapped

Bore size (mm)	O ₁	R
32	M6 x 1.0	10
40	M6 x 1.0	10
50	M8 x 1.25	14

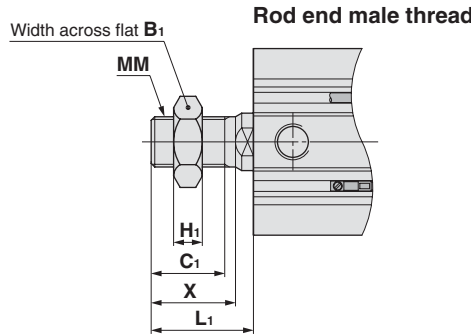
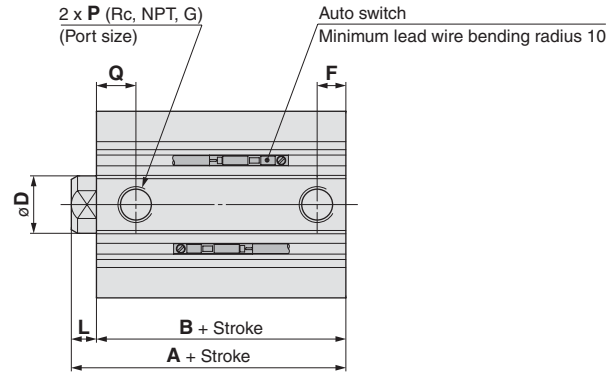
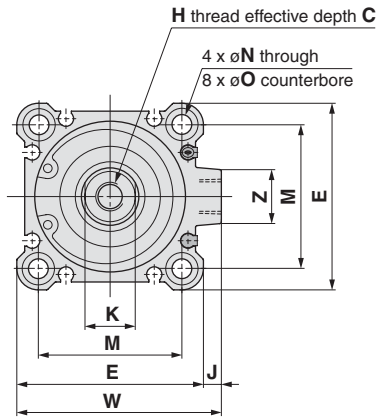

The dimensions with boss on head end are equivalent to those of the CQ2 series, double acting, single rod. Refer to page 14.

Rod End Male Thread (mm)

Bore size (mm)	B ₁	C ₁	H ₁	L ₁	MM	X
32	22	20.5	8	28.5	M14 x 1.5	23.5
40	22	20.5	8	28.5	M14 x 1.5	23.5
50	27	26	11	33.5	M18 x 1.5	28.5

Bore size (mm)	Stroke range (mm)	Without auto switch		With auto switch		C	D	E	F	H	J	K	L	M	N	O	P	Q	W	Z
		A	B	A	B															
32	5 to 50	40	33	50	43	13	16	45	7.5	M8 x 1.25	4.5	14	7	34	5.5	9 depth 7	1/8	10.5	49.5	14
	75, 100	50	43																	
40	5 to 50	46.5	39.5	56.5	49.5	13	16	52	8	M8 x 1.25	5	14	7	40	5.5	9 depth 7	1/8	11	57	15
	75, 100	56.5	49.5																	
50	10 to 50	48.5	40.5	58.5	50.5	15	20	64	10.5	M10 x 1.5	7	17	8	50	6.6	11 depth 8	1/4	10.5	71	19
	75, 100	58.5	50.5																	

Foot: CQ2LS/CDQ2LS

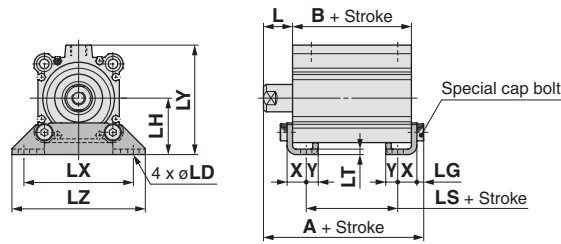

Rod end male thread

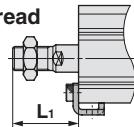

Rod flange: CQ2FS/CDQ2FS

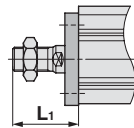
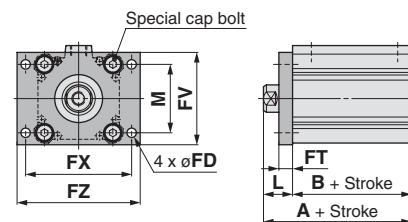

Head flange: CQ2GS/CDQ2GS

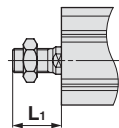
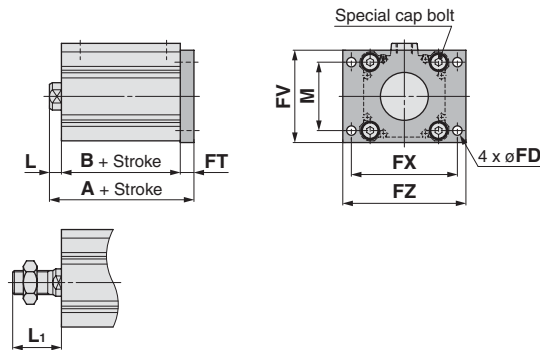

Double clevis: CQ2DS/CDQ2DS

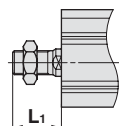
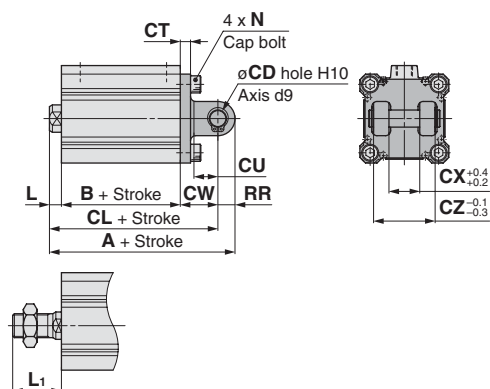

Foot

Bore size (mm)	Stroke range (mm)	Without auto switch			With auto switch			L	L ₁	LD
		A	B	LS	A	B	LS			
32	5 to 50	57.2	33	17	67.2	43	27	17	38.5	6.6
	75, 100	67.2	43	27						
40	5 to 50	63.7	39.5	23.5	73.7	49.5	33.5	17	38.5	6.6
	75, 100	73.7	49.5	33.5						
50	10 to 50	66.7	40.5	17.5	76.7	50.5	27.5	18	43.5	9
	75, 100	76.7	50.5	27.5						

Bore size (mm)	Stroke range (mm)	LG	LH	LT	LX	LY	LZ	X	Y
32	5 to 50	4	30	3.2	57	57	71	11.2	5.8
	75, 100								
40	5 to 50	4	33	3.2	64	64	78	11.2	7
	75, 100								
50	10 to 50	5	39	3.2	79	78	95	14.7	8
	75, 100								

Foot bracket material: Carbon steel
Surface treatment: Nickel plated

Rod Flange

Bore size (mm)	Stroke range (mm)	Without auto switch		With auto switch		FD	FT	FV	FX	FZ
		A	B	A	B					
32	5 to 50	50	33	60	43	5.5	8	48	56	65
	75, 100	60	43							
40	5 to 50	56.5	39.5	66.5	49.5	5.5	8	54	62	72
	75, 100	66.5	49.5							
50	10 to 50	58.5	40.5	68.5	50.5	6.6	9	67	76	89
	75, 100	68.5	50.5							

Bore size (mm)	Stroke range (mm)	L	L ₁	M
32	5 to 50	17	38.5	34
	75, 100			
40	5 to 50	17	38.5	40
	75, 100			
50	10 to 50	18	43.5	50
	75, 100			

Flange bracket material: Carbon steel
Surface treatment: Nickel plated

Head Flange

Bore size (mm)	Stroke range (mm)	Without auto switch		With auto switch		L	L ₁
		A		A			
32	5 to 50	48		58		7	28.5
	75, 100	58					
40	5 to 50	54.5		64.5		7	28.5
	75, 100	64.5					
50	10 to 50	57.5		67.5		8	33.5
	75, 100	67.5					

(* The dimensions except A, L and L₁ are the same as those of the rod flange.) Flange bracket material: Carbon steel
Surface treatment: Nickel plated

Double Clevis

Bore size (mm)	Stroke range (mm)	Without auto switch			With auto switch			CD	CT	CU
		A	B	CL	A	B	CL			
32	5 to 50	70	33	60	80	43	70	10	5	14
	75, 100	80	43	70						
40	5 to 50	78.5	39.5	68.5	88.5	49.5	78.5	10	6	14
	75, 100	88.5	49.5	78.5						
50	10 to 50	90.5	40.5	76.5	100.5	50.5	86.5	14	7	20
	75, 100	100.5	50.5	86.5						

Bore size (mm)	Stroke range (mm)	CW	CX	CZ	L	L ₁	N	RR
32	5 to 50	20	18	36	7	28.5	M6 x 1.0	10
	75, 100							
40	5 to 50	22	18	36	7	28.5	M6 x 1.0	10
	75, 100							
50	10 to 50	28	22	44	8	33.5	M8 x 1.25	14
	75, 100							

Double clevis bracket material: Cast iron
Surface treatment: Painted

* For details about the rod end nut and accessory brackets, refer to page 178.
* Double clevis pin and retaining rings are included.

Standard

Single Acting

Double Rod

Axial Piping

Water Resistant

High Lateral Load

End Lock

Clean Series

Copper/Fluorine free series

Construction and Parts

Warranty and Operating Instructions

Mounting and Auto Switches

Made to Order

Series CQ2 High Lateral Load Dimensions

ø63 to ø100 - With Auto Switch

(Without auto switches, only the A, B dimensions will be changed. Refer to the dimension table.)

Standard (Through-hole): CQ2BS/CDQ2BS

Both ends tapped: CQ2AS/CDQ2AS

The dimensions with boss on head end are equivalent to those of the CQ2 series, double acting, single rod. Refer to page 16.

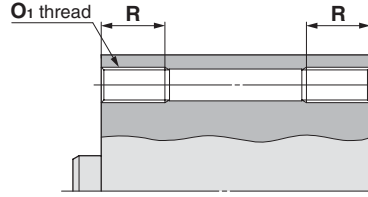

Both Ends Tapped

Bore size (mm)	O ₁	R
63	M10 x 1.5	18
80	M12 x 1.75	22
100	M12 x 1.75	22

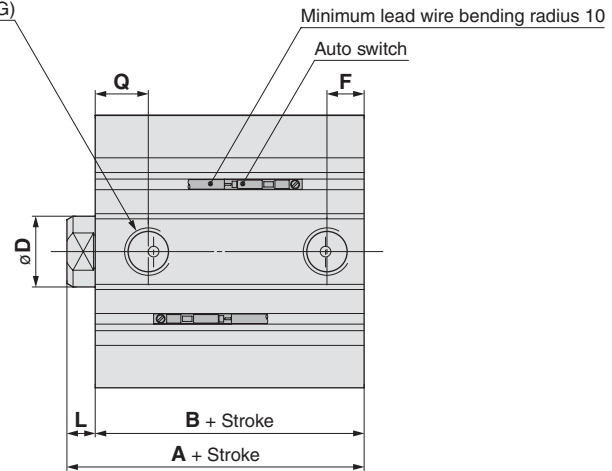
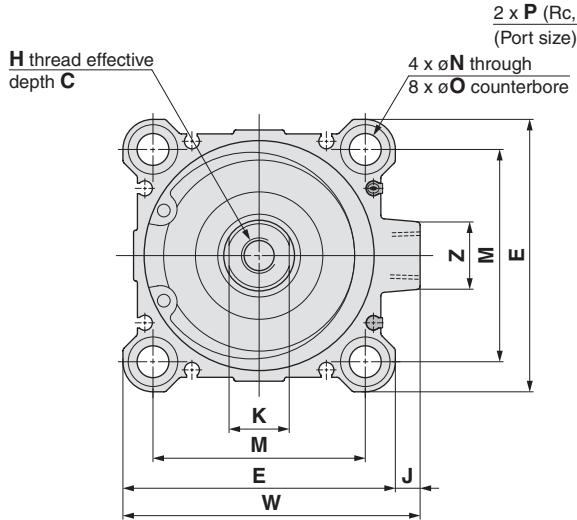

Rod end male thread

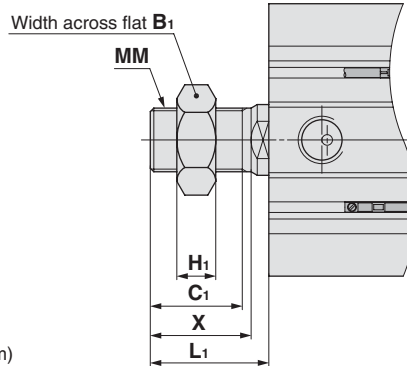

Rod End Male Thread (mm)

Bore size (mm)	B ₁	C ₁	H ₁	L ₁	MM	X
63	27	26	11	33.5	M18 x 1.5	28.5
80	32	32.5	13	43.5	M22 x 1.5	35.5
100	41	32.5	16	43.5	M26 x 1.5	35.5

Bore size (mm)	Stroke range (mm)	Without auto switch		With auto switch		(mm)														
		A	B	A	B	C	D	E	F	H	J	K	L	M	N	O	P	Q	W	Z
63	10 to 50	54	46	64	56	15	20	77	10.5	M10 x 1.5	7	17	8	60	9	14 depth 10.5	1/4	15	84	19
	75, 100	64	56																	
80	10 to 50	63.5	53.5	73.5	63.5	21	25	98	12.5	M16 x 2.0	6	22	10	77	11	17.5 depth 13.5	3/8	16	104	25
	75, 100	73.5	63.5																	
100	10 to 50	75	63	85	73	27	30	117	13	M20 x 2.5	6.5	27	12	94	11	17.5 depth 13.5	3/8	23	123.5	25
	75, 100	85	73																	

Foot: CQ2LS/CDQ2LS

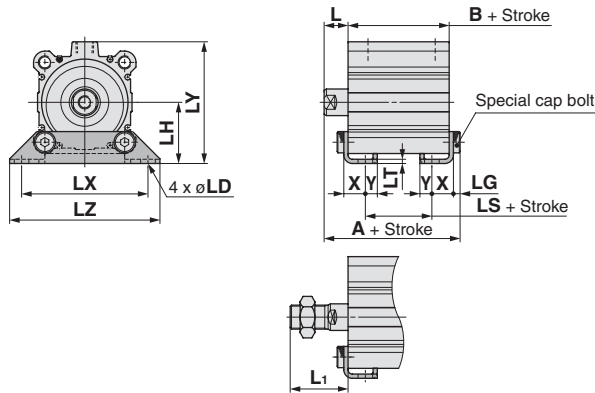

Rod flange: CQ2FS/CDQ2FS

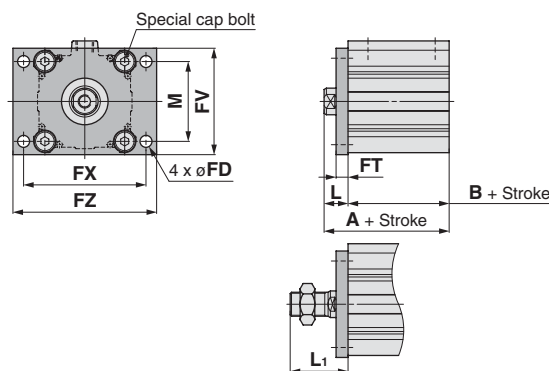

Head flange: CQ2GS/CDQ2GS

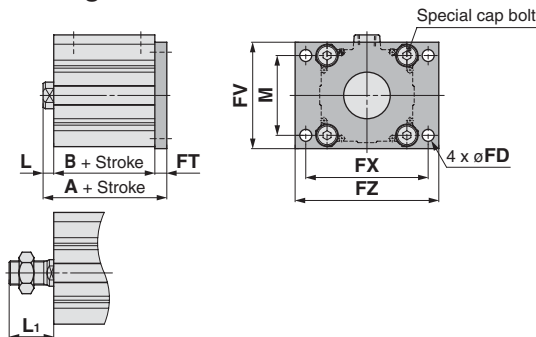

Double clevis: CQ2DS/CDQ2DS

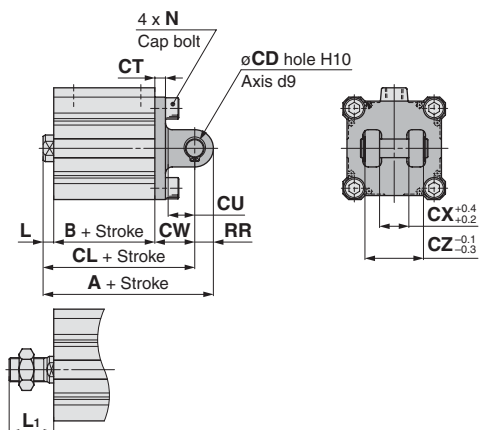

Foot

Bore size (mm)	Stroke range (mm)	Without auto switch			With auto switch			L	L ₁	LD
		A	B	LS	A	B	LS			
63	10 to 50	72.2	46	20	82.2	56	30	18	43.5	11
	75, 100	82.2	56	30						
80	10 to 50	85	53.5	23.5	95	63.5	33.5	20	53.5	13
	75, 100	95	63.5	33.5						
100	10 to 50	98	63	29	108	73	39	22	53.5	13
	75, 100	108	73	39						

Bore size (mm)	Stroke range (mm)	LG	LH	LT	LX	LY	LZ	X	Y
63	10 to 50	5	46	3.2	95	91.5	113	16.2	9
	75, 100								
80	10 to 50	7	59	4.5	118	114	140	19.5	11
	75, 100								
100	10 to 50	7	71	6	137	136	162	23	12.5
	75, 100								

Foot bracket material: Carbon steel
Surface treatment: Nickel plated

Rod Flange

Bore size (mm)	Stroke range (mm)	Without auto switch		With auto switch		FD	FT	FV	FX	FZ
		A	B	A	B					
63	10 to 50	64	46	74	56	9	9	80	92	108
	75, 100	74	56							
80	10 to 50	73.5	53.5	83.5	63.5	11	11	99	116	134
	75, 100	83.5	63.5							
100	10 to 50	85	63	95	73	11	11	117	136	154
	75, 100	95	73							

Bore size (mm)	Stroke range (mm)	L	L ₁	M
63	10 to 50	18	43.5	60
	75, 100			
80	10 to 50	20	53.5	77
	75, 100			
100	10 to 50	22	53.5	94
	75, 100			

Flange bracket material: Carbon steel
Surface treatment: Nickel plated

Head Flange

Bore size (mm)	Stroke range (mm)	Without auto switch		With auto switch		L	L ₁
		A		A			
63	10 to 50	63		73		8	33.5
	75, 100	73					
80	10 to 50	74.5		84.5		10	43.5
	75, 100	84.5					
100	10 to 50	86		96		12	43.5
	75, 100	96					

(* The dimensions except A, L and L₁ are the same as those of the rod flange.) Flange bracket material: Carbon steel
Surface treatment: Nickel plated

Double Clevis

Bore size (mm)	Stroke range (mm)	Without auto switch			With auto switch			CD	CT	CU
		A	B	CL	A	B	CL			
63	10 to 50	98	46	84	108	56	94	14	8	20
	75, 100	108	56	94						
80	10 to 50	119.5	53.5	101.5	129.5	63.5	111.5	18	10	27
	75, 100	129.5	63.5	111.5						
100	10 to 50	142	63	120	152	73	130	22	13	31
	75, 100	152	73	130						

Bore size (mm)	Stroke range (mm)	CW	CX	CZ	L	L ₁	N	RR
63	10 to 50	30	22	44	8	33.5	M10 x 1.5	14
	75, 100							
80	10 to 50	38	28	56	10	43.5	M12 x 1.75	18
	75, 100							
100	10 to 50	45	32	64	12	43.5	M12 x 1.75	22
	75, 100							

Double clevis bracket material: Cast iron
Surface treatment: Painted

* For details about the rod end nut and accessory brackets, refer to page 178.
* Double clevis pin and retaining rings are included.

Standard

Single Acting

Double Rod

Axial Piping

Water Resistant

High Lateral Load

End Lock

Clean Series

Copper/Fluorine free series

Construction and Parts

Warranty and Operating Instructions

Mounting and Auto Switches

Made to Order

How to Order

C D BQ2 B 32 - 30 D C H L -

Magnet

Nil	Without magnet
D	With magnet

Mounting

B	Through hole (std.)
A	Threaded
D	Clevis
L	Foot
G	Head flange
F	Rod flange

* Mounting brackets are shipped together, (but not assembled).
 * Cylinder mounting bolts are not included. Order them separately referring to "Mounting Bolt for C(D)Q2B" on pages 156 and 157.

Bore size

20	20 mm
25	25 mm
32	32 mm
40	40 mm
50	50 mm
63	63 mm
80	80 mm
100	100 mm

Port thread type

Nil	Rc
TN	NPT
TF	G

Stroke standard (pneumatic)

Bore	Stroke standard (pneumatic)										Long stroke							
	5	10	15	20	25	30	35	40	45	50	75	100	125	150	175	200	250	300
20	●	●	●	●	●	●												
25	●	●	●	●	●	●												
32	●	●	●	●	●	●	●	●	●									
40	●	●	●	●	●	●	●	●	●	●								
50	●	●	●	●	●	●	●	●	●	●	●	●	●	●	●	●	●	●
63	●	●	●	●	●	●	●	●	●	●	●	●	●	●	●	●	●	●
80		●	●	●	●	●	●	●	●	●	●	●	●	●	●	●	●	●
100		●	●	●	●	●	●	●	●	●	●	●	●	●	●	●	●	●

Switch

M9	Solid state switch (see page 181 for details)
A9	Reed switch

Manual release

N	Non-lock type
L	Lock type

Lock position

H	Head end lock
R	Rod end lock

Option

Nil	Standard (Rod end female thread)
C	With rubber bumper
M	Rod end male thread

Bumper

C	Rubber bumper
---	---------------

- Standard
- Single Acting
- Double Rod
- Axial Piping
- Water Resistant
- High Lateral Load
- End Lock
- Clean Series
- Copper/Fluorine free series
- Construction and Parts
- Warranty and Operating Instructions
- Mounting and Auto Switches
- Made to Order



Specifications

Bore size (mm)	20	25	32	40	50	63	80	100
Action	Double acting, Single rod							
Fluid	Air							
Proof pressure	218 psi (1.5 MPa)							
Maximum operating pressure	145 psi (1.0 MPa)							
Minimum operating pressure	22 psi (0.15 MPa ^{Note})							
Ambient and fluid temperature	Without auto switch: -10 to 70°C (No freezing) With auto switch: -10 to 60°C (No freezing)							
Lubrication	Not required (Non-lube)							
Piston speed	50 to 500 mm/s							
Allowable kinetic energy (J)	0.055	0.09	0.15	0.26	0.46	0.77	1.36	2.27
Stroke length tolerance	+1.0 mm 0							
Lock position	Head end, Rod end							
Holding force (Max.) (N)	215	330	550	860	1340	2140	3450	5390
Pressure for unlocking	0.15 MPa or less							
Backlash	2 mm or less							
Manual release	Non-lock type, Lock type							

Note) 0.05 MPa except for the end lock unit

Standard Strokes

Bore size	Standard stroke
20 to 63	10, 15, 20, 25, 50, 75, 100
80, 100	25, 50, 75, 100

Manufacture of Intermediate Strokes

Type	A spacer is installed in the standard stroke body.	
Part no.	Refer to "How to Order" for the standard model number. (P. 113)	
Description	Strokes in 5 mm intervals are available by installing a spacer in the standard stroke cylinder.	
Stroke range	Bore size	Stroke range
	20 to 100	5 to 95
Example	Part no.: CBQ2B40-45DC-HL CBQ2B40-50DC-HL with 5 mm width spacer inside	

Conversions

°F = 1.8°C + 32 1 J = 0.738 ft-lb
1 MPa = 145 psi 1 mm = 0.039 in

Allowable Kinetic Energy

With Rubber Bumper

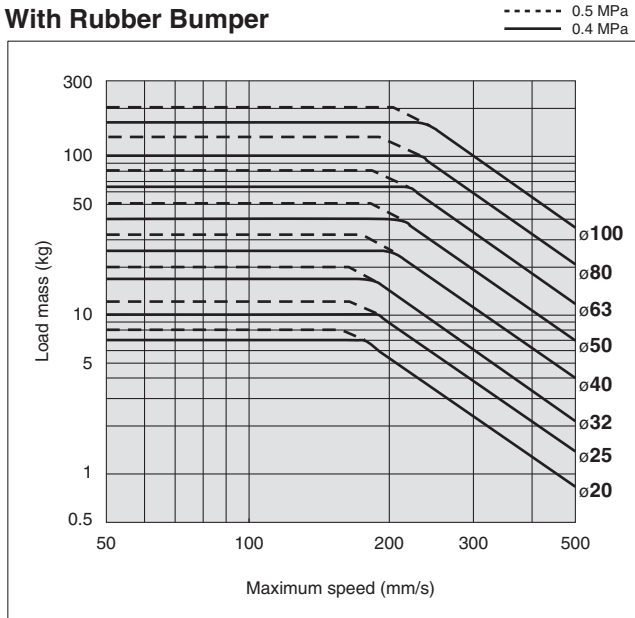

Allowable Lateral Load at Rod End

With Auto Switch

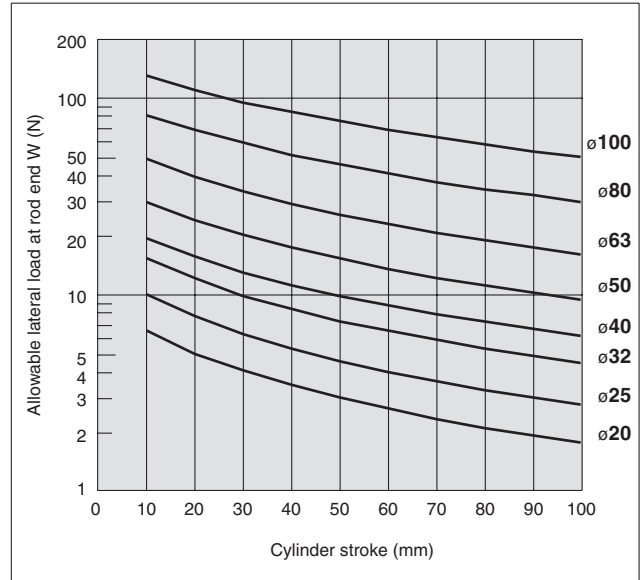

1g = 0.0353 oz
 1kg = 2.2046 lb
 1mm = 0.039 in

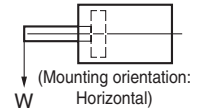

- Standard
- Single Acting
- Double Rod
- Axial Piping
- Water Resistant
- High Lateral Load
- End Lock**
- Clean Series
- Copper/Fluorine free series
- Construction and Parts
- Warranty and Operating Instructions
- Mounting and Auto Switches
- Made to Order

ø20, ø25

Standard (Through-hole/Both ends tapped common):
CBQ2B/CDBQ2B

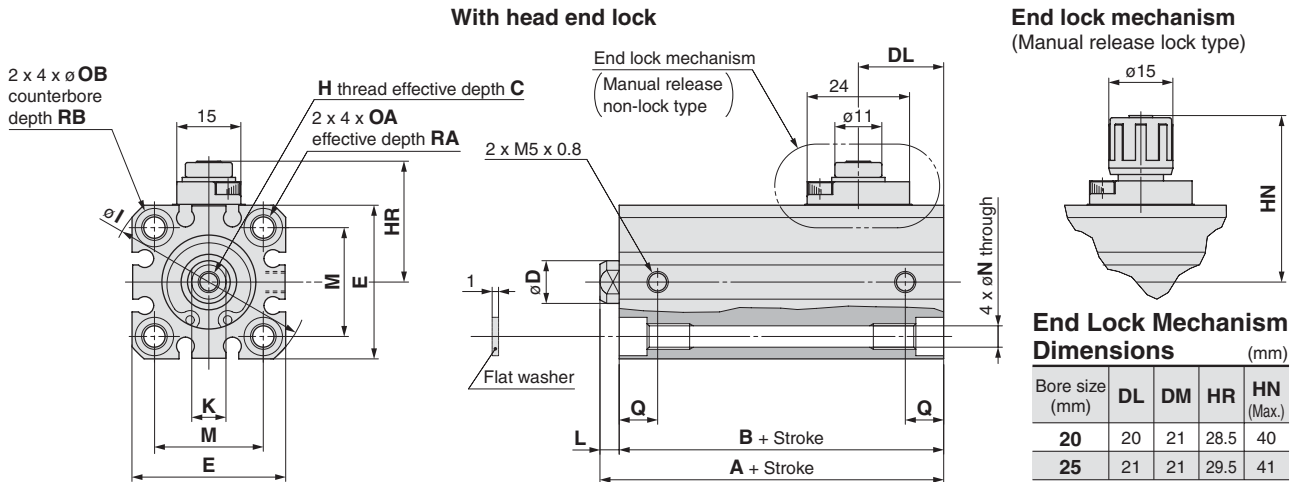

With rod end lock

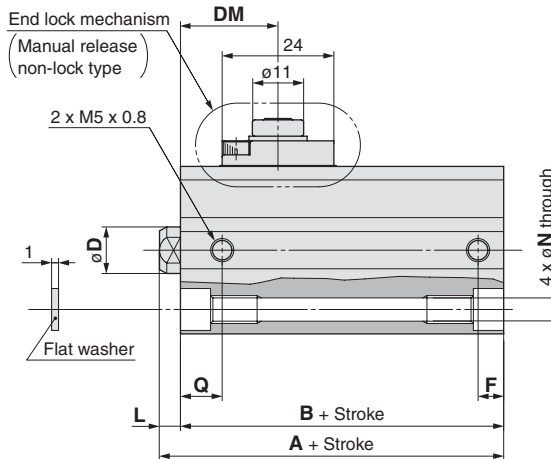

Rod end male thread

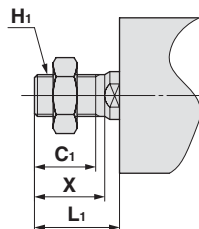

Rod End Male Thread

Bore size (mm)	Standard stroke	C ₁	X	H ₁	L ₁
20	10, 15, 20, 25	12	14	M8 x 1.25	18.5
	50, 75, 100				28.5
25	10, 15, 20, 25	15	17.5	M10 x 1.25	22.5
	50, 75, 100				32.5

Bore size (mm)	Standard stroke	With head end lock			With rod end lock				C	D	E	H	I	K	M	N	OA	OB	Q	RA	RB
		A	B	L	A	B	F	L													
20	10, 15, 20, 25	65.5	61	4.5	59	54.5	5.5	4.5	7	10	36	M5 x 0.8	47	8	25.5	5.4	M6 x 1.0	9	9	10	7
	50, 75, 100	80.5	66	14.5	80.5	66	9	14.5													
25	10, 15, 20, 25	69	64	5	62.5	57.5	5.5	5	12	12	40	M6 x 1.0	52	10	28	5.4	M6 x 1.0	9	11	10	7
	50, 75, 100	84	69	15	84	69	11	15													

Foot: CBQ2L/CDBQ2L

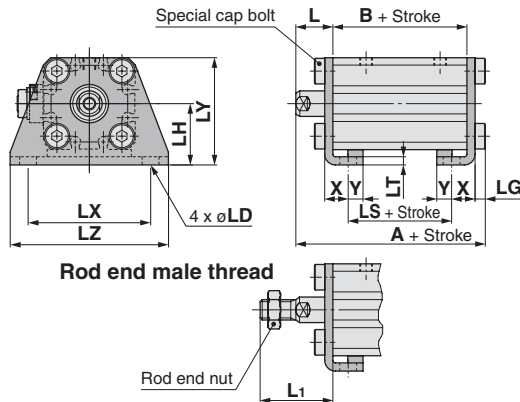

Foot

Bore size (mm)	Standard stroke	With head end lock			With rod end lock		
		A	B	LS	A	B	LS
20	10, 15, 20, 25	82.7	61	49	76.2	54.5	42.5
	50, 75, 100	87.7	66	54	87.7	66	54
25	10, 15, 20, 25	86.2	64	49	79.7	57.5	42.5
	50, 75, 100	91.2	69	54	91.2	69	54

Bore size (mm)	Standard stroke	L	L ₁	LD	LG	LH	LT	LX	LY	LZ	X	Y
		20	10, 15, 20, 25	14.5	28.5	6.6	4	24	3.2	48	42	62
25	50, 75, 100	15	32.5	6.6	4	26	3.2	52	46	66	10.7	5.8

Foot bracket material: Carbon steel
Surface treatment: Nickel plated

Rod flange: CBQ2F/CDBQ2F

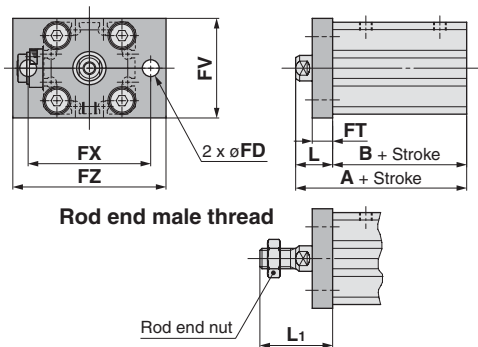

Rod Flange

Bore size (mm)	Standard Stroke	With head end lock		With rod end lock	
		A	B	A	B
20	10, 15, 20, 25	75.5	61	69	54.5
	50, 75, 100	80.5	66	80.5	66
25	10, 15, 20, 25	79	64	72.5	57.5
	50, 75, 100	84	69	84	69

Bore size (mm)	Standard stroke	FD	FT	FV	FX	FZ	L	L ₁
		20	10, 15, 20, 25	6.6	8	39	48	60
25	50, 75, 100	6.6	8	42	52	64	15	32.5

Flange bracket material: Carbon steel
Surface treatment: Nickel plated

Head flange: CBQ2G/CDBQ2G

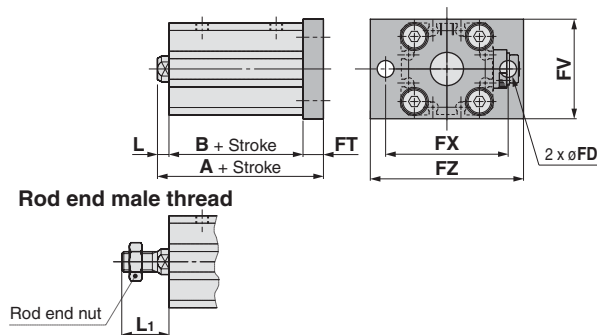

Head Flange

Bore size (mm)	Standard stroke	With head end lock				With rod end lock			
		A	B	L	L ₁	A	B	L	L ₁
20	10, 15, 20, 25	73.5	61	4.5	18.5	67	54.5	4.5	18.5
	50, 75, 100	88.5	66	14.5	28.5	88.5	66	14.5	28.5
25	10, 15, 20, 25	77	64	5	22.5	70.5	57.5	5	22.5
	50, 75, 100	92	69	15	32.5	92	69	15	32.5

Bore size (mm)	Standard stroke	FD	FT	FV	FX	FZ
		20	10, 15, 20, 25	6.6	8	39
25	50, 75, 100	6.6	8	42	52	64

Flange bracket material: Carbon steel
Surface treatment: Nickel plated

Double clevis: CBQ2D/CDBQ2D

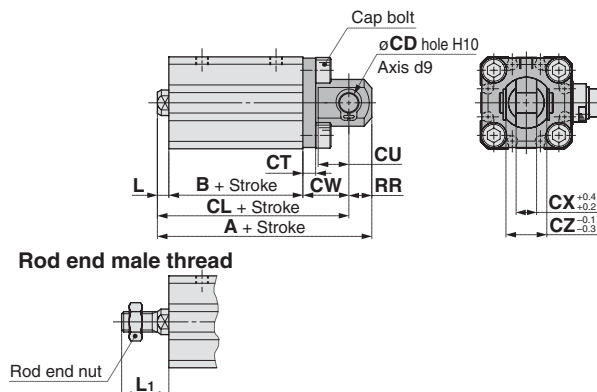

Double Clevis

Bore size (mm)	Standard stroke	With head end lock					With rod end lock				
		A	B	CL	L	L ₁	A	B	CL	L	L ₁
20	10, 15, 20, 25	92.5	61	83.5	4.5	18.5	86	54.5	77	4.5	18.5
	50, 75, 100	107.5	66	98.5	14.5	28.5	107.5	66	98.5	14.5	28.5
25	10, 15, 20, 25	99	64	89	5	22.5	92.5	57.5	82.5	5	22.5
	50, 75, 100	114	69	104	15	32.5	114	69	104	15	32.5

Bore size (mm)	Standard stroke	CD	CT	CU	CW	CX	CZ	RR
		20	10, 15, 20, 25	8	5	12	18	8
25	50, 75, 100	10	5	14	20	10	20	10

Double clevis bracket material: Carbon steel
Surface treatment: Nickel plated

- Standard
- Single Acting
- Double Rod
- Axial Piping
- Water Resistant
- High Lateral Load
- End Lock
- Clean Series
- Copper/Fluorine free series
- Construction and Parts
- Warranty and Operating Instructions
- Mounting and Auto Switches
- Made to Order

Foot: CBQ2L/CDBQ2L

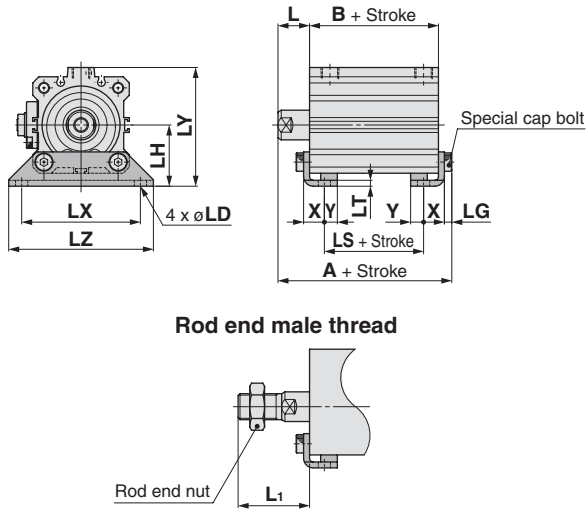

Foot

Bore size (mm)	Standard stroke	With head end lock			With rod end lock			(mm)		
		A	B	LS	A	B	LS	L	L ₁	LD
32	10, 15, 20, 25 50, 75, 100	89.7	65.5	49.5	82.2	58	42	17	38.5	6.6
40		99.2	75	59	88.7	64.5	48.5	17	38.5	6.6
50		101.7	75.5	52.5	91.7	65.5	42.5	18	43.5	9
63	25, 50 75, 100	103.2	77	51	97.2	71	45	18	43.5	11
80		142.5	111	81	135	103.5	73.5	20	53.5	13
100	25, 50	147.5	116	86	147.5	116	86	22	53.5	13
	75, 100	155.5	120.5	86.5	148	113	79			
100	25, 50	160.5	125.5	91.5	160.5	125.5	91.5	22	53.5	13
	75, 100	160.5	125.5	91.5	160.5	125.5	91.5			

Bore size (mm)	Standard stroke	LG	LH	LT	LX	LY	LZ	X	Y
32	10, 15, 20, 25 50, 75, 100	4	30	3.2	57	57	71	11.2	5.8
40		4	33	3.2	64	64	78	11.2	7
50		5	39	3.2	79	78	95	14.7	8
63	25, 50, 75, 100	5	46	3.2	95	91.5	113	16.2	9
80		7	59	4.5	118	114	140	19.5	11
100	7	71	6	137	136	162	23	12.5	

Foot bracket material: Carbon steel
Surface treatment: Nickel plated

Rod flange: CBQ2F/CDBQ2F

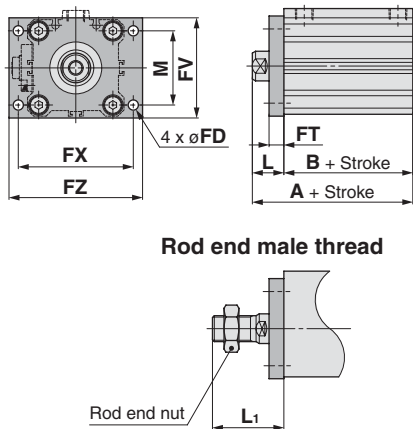

Rod Flange

Bore size (mm)	Standard stroke	With head end lock		With rod end lock		FD	FT	FV	FX	FZ
		A	B	A	B					
32	10, 15, 20, 25 50, 75, 100	82.5	65.5	75	58	5.5	8	48	56	65
40		92	75	81.5	64.5	5.5	8	54	62	72
50		93.5	75.5	83.5	65.5	6.6	9	67	76	89
63	25, 50 75, 100	95	77	89	71	9	9	80	92	108
80		131	111	123.5	103.5	11	11	99	116	134
100	25, 50	136	116	136	116	11	11	117	136	154
	75, 100	142.5	120.5	135	113					
100	75, 100	147.5	125.5	147.5	125.5					

Bore size (mm)	Standard stroke	L	L ₁	M
32	10, 15, 20, 25 50, 75, 100	17	38.5	34
40		17	38.5	40
50		18	43.5	50
63	25, 50, 75, 100	18	43.5	60
80		20	53.5	77
100	22	53.5	94	

Flange bracket material: Carbon steel
Surface treatment: Nickel plated

- Standard
- Single Acting
- Double Rod
- Axial Piping
- Water Resistant
- High Lateral Load
- End Lock
- Clean Series
- Copper/Fluorine free series
- Construction and Parts
- Warranty and Operating Instructions
- Mounting and Auto Switches
- Made to Order

ø32 to ø100

Head flange: CBQ2G/CDBQ2G

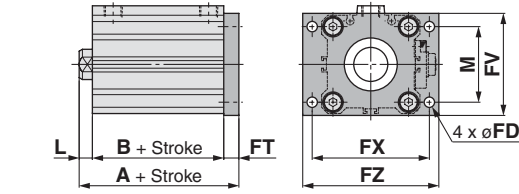

Rod end male thread

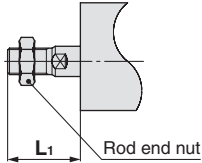

Head Flange

(mm)

Bore size (mm)	Standard stroke	With head end lock				With rod end lock			
		A	B	L	L ₁	A	B	L	L ₁
32	10, 15, 20, 25 50, 75, 100	80.5	65.5	7	28.5	73	58	7	28.5
40		90	75	7	28.5	79.5	64.5	7	28.5
50		92.5	75.5	8	33.5	82.5	65.5	8	33.5
63		94	77	8	33.5	88	71	8	33.5
80	25, 50	132	111	10	43.5	124.5	103.5	10	43.5
	75, 100	147	116	20	53.5	147	116	20	53.5
100	25, 50	143.5	120.5	12	43.5	136	113	12	43.5
	75, 100	158.5	125.5	22	53.5	158.5	125.5	22	53.5

Bore size (mm)	Standard stroke	M	FD	FT	FV	FX	FZ
32	10, 15, 20, 25 50, 75, 100	34	5.5	8	48	56	65
40		40	5.5	8	54	62	72
50		50	6.6	9	67	76	89
63		60	9	9	80	92	108
80		77	11	11	99	116	134
100		94	11	11	117	136	154

Flange bracket material: Carbon steel
Surface treatment: Nickel plated

Double clevis: CBQ2D/CDBQ2D

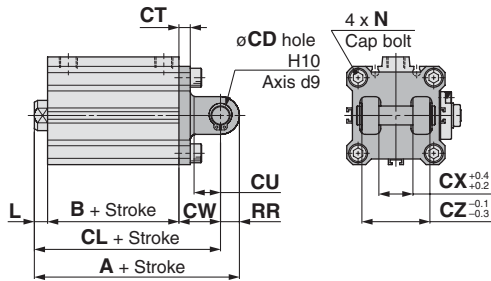

Rod end male thread

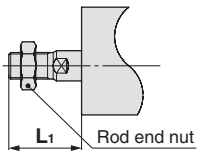

Double Clevis

(mm)

Bore size (mm)	Standard stroke	With head end lock			With rod end lock			CD	CT	CU	L	L ₁
		A	B	CL	A	B	CL					
32	10, 15, 20, 25 50, 75, 100	102.5	65.5	92.5	95	58	85	10	5	14	7	28.5
40		114	75	104	103.5	64.5	93.5	10	6	14	7	28.5
50		125.5	75.5	111.5	115.5	65.5	101.5	14	7	20	8	33.5
63		129	77	115	123	71	109	14	8	20	8	33.5
80	25, 50	177	111	159	169.5	103.5	151.5	18	10	27	10	43.5
	75, 100	192	116	174	192	116	174				20	53.5
100	25, 50	199.5	120.5	177.5	192	113	170	22	13	31	12	43.5
	75, 100	214.5	125.5	192.5	214.5	125.5	192.5				22	53.5

Bore size (mm)	Standard stroke	CW	CX	CZ	N	RR
32	10, 15, 20, 25 50, 75, 100	20	18	36	M6 x 1.0	10
40		22	18	36	M6 x 1.0	10
50		28	22	44	M8 x 1.25	14
63		30	22	44	M10 x 1.5	14
80		38	28	56	M12 x 1.75	18
100		45	32	64	M12 x 1.75	22

Double clevis bracket material: Cast iron
Surface treatment: Painted

Clean Series

10 - C □ **Q2B** Bore size - Stroke **D(M)Z**

• Clean series

10	Relief type
11	Vacuum type

• $\phi 12, \phi 16, \phi 20, \phi 25, \phi 32$
 $\phi 40, \phi 50, \phi 63, \phi 80, \phi 100$

Applicable for using inside the clean room graded Class 100 by making an actuator's rod section a double seal construction and discharging by relief port directly to the outside of clean room.



Specifications

Bore size (mm)	12	16	20	25	32	40	50	63	80	100
Action	Double acting, Single rod									
Proof pressure	218 psi (1.5 MPa)									
Maximum operating pressure	145 psi (1.0 MPa)									
Cushion	None <small>Note</small>									
Piston speed	30 to 400 mm/s								30 to 300 mm/s	
Mounting	Through-hole									

Note $\phi 12$ with auto switch: With rubber bumper (Standard)

For details, refer to the separate catalog (CAT.E02-23), "Pneumatics Equipment for Clean Room."

Construction

10-CQ2 series
(Double seal)

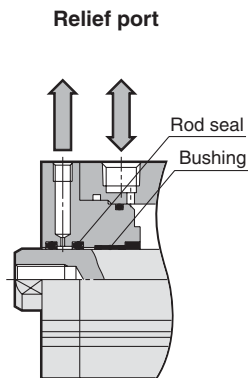

A relief port is provided in the area between the double rod seals to discharge the exhaust air outside of the clean room. Thus, the amount of dust generated has been reduced to 1/20 of that of an ordinary cylinder.

1 MPa = 145 psi
 1 mm = 0.039 in

11-CQ2 series
(Single seal, Vacuum suction)

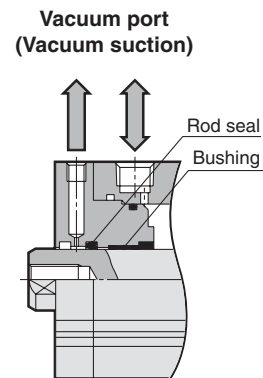

Structurally identical to the "10-" series, the outer rod seal has been removed to evacuate through the vacuum port. This draws out any external air from the clearance between the rod and the cover to practically eliminate the generation of external dust. This should be used in an application that requires an even higher level of cleanliness than the 10- series.

- Standard
- Single Acting
- Double Rod
- Axial Piping
- Water Resistant
- High Lateral Load
- End Lock
- Clean Series
- Copper/Fluorine free series
- Construction and Parts
- Warranty and Operating Instructions
- Mounting and Auto Switches
- Made to Order

Copper and Fluorine-free Series (For CRT Manufacturing Process)

For preventing the influence of copper ions or halogen ions during CRT manufacturing processes, copper and fluorine materials are not used in the component parts.

Double Acting, Single Rod

20 – C□Q2B Bore size – Stroke **D(C)(M)Z**

• Copper and fluorine-free series

• $\varnothing 12, \varnothing 16, \varnothing 20, \varnothing 25, \varnothing 32$
 $\varnothing 40, \varnothing 50, \varnothing 63, \varnothing 80, \varnothing 100$

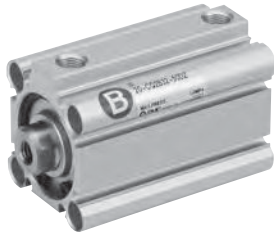

Specifications

Bore size (mm)	12	16	20	25	32	40	50	63	80	100
Action	Double acting, Single rod									
Proof pressure	218 psi (1.5 MPa)									
Maximum operating pressure	145 psi (1.0 MPa)									
Cushion	None/Rubber bumper									
Piston speed	50 to 500 mm/s									
Mounting	Through-hole/Both ends tapped									

Double Acting, Double Rod

20 – CQ2WB Bore size – Stroke **D(C)(M)Z**

• Copper and fluorine-free series

• $\varnothing 12, \varnothing 16, \varnothing 20, \varnothing 25, \varnothing 32$
 $\varnothing 40, \varnothing 50, \varnothing 63, \varnothing 80, \varnothing 100$

Specifications

Bore size (mm)	12	16	20	25	32	40	50	63	80	100
Action	Double acting, Double rod									
Proof pressure	218 psi (1.5 MPa)									
Max. operating pressure	145 psi (1.0 MPa)									
Rubber bumper	None									
Piping	Pipe thread									
Piston speed	50 to 500 mm/s									
Mounting	Through-hole									
Auto switch	Mountable									

1 MPa = 145 psi
 1 mm = 0.039 in

Copper and Fluorine-free Series (For CRT Manufacturing Process)

For preventing the influence of copper ions or halogen ions during CRT manufacturing processes, copper and fluorine materials are not used in the component parts.

Single Acting

20 — C□Q2B Bore size — Stroke $\frac{S}{T}$ (M)Z
 • Copper and fluorine-free series — $\phi 12, \phi 16, \phi 20, \phi 25, \phi 32, \phi 40, \phi 50$

Specifications

Bore size (mm)	12	16	20	25	32	40	50
Action	Single acting, Single rod						
Proof pressure	218 psi (1.5 MPa)						
Max. operating pressure	145 psi (1.0 MPa)						
Rubber bumper	None						
Piping	Pipe thread						
Piston speed	50 to 500 mm/s						
Mounting	Through-hole						
Auto switch	Mountable						

Non-Rotating Rod, Double Acting, Single Rod

20 — CQ2KB Bore size — Stroke D(M)Z
 • Copper and fluorine-free series — $\phi 16, \phi 20, \phi 25, \phi 32, \phi 40, \phi 50, \phi 63$

Specifications

Bore size (mm)	16	20	25	32	40	50	63
Action	Double acting, Single rod						
Proof pressure	218 psi (1.5 MPa)						
Max. operating pressure	145 psi (1.0 MPa)						
Rubber bumper	None						
Piping	Pipe thread						
Piston speed	50 to 500 mm/s						
Mounting	Through-hole						
Auto switch	Mountable						

Non-Rotating Rod, Double Acting, Double Rod

20 — CQ2KWB Bore size — Stroke D(M)Z
 • Copper and fluorine-free series — $\phi 16, \phi 20, \phi 25, \phi 32, \phi 40, \phi 50, \phi 63$

Specifications

Bore size (mm)	16	20	25	32	40	50	63
Action	Double acting, Double rod						
Proof pressure	218 psi (1.5 MPa)						
Max. operating pressure	145 psi (1.0 MPa)						
Rubber bumper	None						
Piping	Pipe thread						
Piston speed	50 to 500 mm/s						
Mounting	Through-hole						
Auto switch	Mountable						

1 MPa = 145 psi
 1 mm = 0.039 in

Standard

Single Acting

Double Rod

Axial Piping

Water Resistant

High Lateral Load

End Lock

Clean Series

Copper/Fluorine free series

Construction and Parts

Warranty and Operating Instructions

Mounting and Auto Switches

Made to Order

Copper and Fluorine-free Series (For CRT Manufacturing Process)

For preventing the influence of copper ions or halogen ions during CRT manufacturing processes, copper and fluorine materials are not used in the component parts.

Axial Piping, Double Acting, Single Rod

20 – CQP2B Bore size – Stroke D
 • Copper and fluorine-free series
 • $\phi 12, \phi 16, \phi 20, \phi 25, \phi 32, \phi 40, \phi 50, \phi 63, \phi 80, \phi 100$

Specifications

Bore size (mm)	12	16	20	25	32	40	50	63	80	100
Action	Double acting, Single rod									
Proof pressure	281 psi (1.5 MPa)									
Max. operating pressure	145 psi (1.0 MPa)									
Rubber bumper	None									
Piping	Pipe thread									
Piston speed	50 to 500 mm/s									
Mounting	Through-hole									
Auto switch	Mountable									

Axial Piping, Single Acting, Single Rod

20 – CQP2B Bore size – Stroke $\frac{S}{T}$ (M)
 • Copper and fluorine-free series
 • $\phi 12, \phi 16, \phi 20, \phi 25, \phi 32, \phi 40, \phi 50$

Specifications

Bore size (mm)	12	16	20	25	32	40	50
Action	Single acting, Single rod						
Proof pressure	281 psi (1.5 MPa)						
Max. operating pressure	145 psi (1.0 MPa)						
Rubber bumper	None						
Piping	Pipe thread						
Piston speed	50 to 500 mm/s						
Mounting	Through-hole						
Auto switch	Mountable						

High Lateral Load

20-CQ2BS Bore size – Stroke DC(M)Z
 • Copper and fluorine-free series
 • $\phi 32, \phi 40, \phi 50, \phi 63, \phi 80, \phi 100$

Specifications

Bore size (mm)	32	40	50	63	80	100
Action	Double acting, Single rod					
Proof pressure	281 psi (1.5 MPa)					
Max. operating pressure	145 psi (1.0 MPa)					
Rubber bumper	With (Standard)					
Piping	Pipe thread					
Piston speed	50 to 500 mm/s					
Mounting	Through-hole/Both ends tapped					
Auto switch	Mountable					

1 MPa = 145 psi
 1 mm = 0.039 in

Construction and Replacement Parts

series	Type	page
CQ2	Standard	126
	With auto switch	127
	Large bore	128
	Long stroke	129
CQ2K	Non-rotating rod	130
	Non-rotating rod, with auto switch	131
CQ2 ^S _T	Single Acting	132
	With auto switch	133
CQ2W	Double Rod	134
	With auto switch	135
	Large bore	136
CQ2KW	Non-rotating rod	137
	Non-rotating rod, with auto switch	138
CQP2	Axial Piping	139
	With auto switch	140
CQP2 ^S _T	Single acting	141
	Single acting, with auto switch	142
CQ2□S	High Lateral Load	143
	With auto switch	144
CBQ2	End Lock	146
CQ2 ^R _V	Water Resistant	148
	With auto switch	149

Standard

Single Acting

Double Rod

Axial Piping

Water Resistant

High Lateral Load

End Lock

Clean Series

Copper/Fluorine free series

Construction and Parts

Warranty and Operating Instructions

Mounting and Auto Switches

Made to Order

Construction

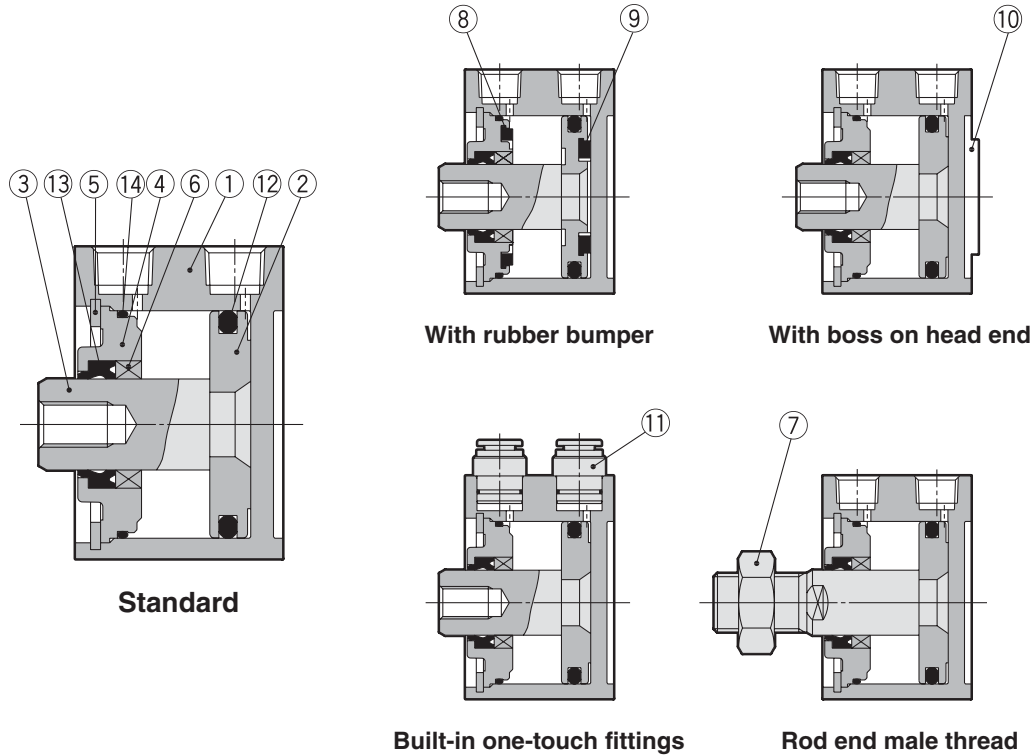

Component Parts

No.	Description	Material	Note
1	Cylinder tube	Aluminum alloy	Hard anodized
2	Piston	Aluminum alloy	Chromated
3	Piston rod	Stainless steel	ø12 to ø25
		Carbon steel	ø32 to ø100, Hard chrome plated
4	Collar	Aluminum alloy	ø12 to ø40, Anodized
		Aluminum alloy cast	ø50 to ø100, Chromated, painted
5	Retaining ring	Carbon tool steel	Phosphate coated
6	Bushing	Bearing alloy	For ø50 or more only
7	Rod end nut	Carbon steel	Nickel plated
8	Bumper A	Urethane	

No.	Description	Material	Note
9	Bumper B	Urethane	
10	Centering location ring	Aluminum alloy	ø20 to ø100, Hard anodized
11	One-touch fitting	—	ø32 to ø63
12	Piston seal	NBR	
13	Rod seal	NBR	
14	Gasket	NBR	

Replacement Parts/Seal Kit (Pneumatic type)

Bore size (mm)	Kit no.	Contents
12	CQ2B12-PS	Kits include items 12, 13, 14 from the table.
16	CQ2B16-PS	
20	CQ2B20-PS	
25	CQ2B25-PS	
32	CQ2B32-PS	
40	CQ2B40-PS	
50	CQ2B50-PS	
63	CQ2B63-PS	
80	CQ2B80-PS	
100	CQ2B100-PS	

Replacement Parts/Seal Kit (Air-hydro type)

Bore size (mm)	Kit no.	Contents
20	CQ2BH20-PS	Kits include items 12, 13, 14 from the table.
25	CQ2BH25-PS	
32	CQ2BH32-PS	
40	CQ2BH40-PS	
50	CQ2BH50-PS	
63	CQ2BH63-PS	
80	CQ2BH80-PS	
100	CQ2BH100-PS	

* Seal kit includes 12, 13, 14. Order the seal kit, based on each bore size.
 * Since the seal kit does not include a grease pack, order it separately.
Grease pack part no.: GR-S-010 (10 g)

* Seal kit includes 12, 13, 14. Order the seal kit based on each bore size.
 * The seal kit does not include a grease pack, order it separately.
Grease pack part no.: GR-S-010 (10 g)

Construction

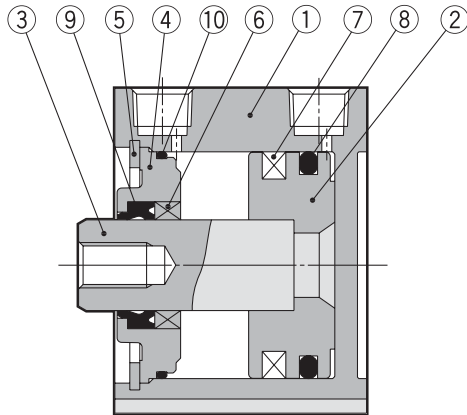

Component Parts

No.	Description	Material	Note
1	Cylinder tube	Aluminum alloy	Hard anodized
2	Piston	Aluminum alloy	Chromated
3	Piston rod	Stainless steel	ø12 to ø25
		Carbon steel	ø32 to ø100, Hard chrome plated
4	Collar	Aluminum alloy	ø12 to ø40, Anodized
		Aluminum alloy cast	ø50 to ø100, Chromated, Painted
5	Retaining ring	Carbon tool steel	Phosphate coated
6	Bushing	Bearing alloy	For ø50 or more only
7	Magnet	-	
8	Piston seal	NBR	
9	Rod seal	NBR	
10	Gasket	NBR	

Replacement Parts/Seal Kit (Pneumatic type)

Bore size (mm)	Kit no.	Contents
12	CQ2B12-PS	Kits include items ⑧, ⑨, ⑩ from the table.
16	CQ2B16-PS	
20	CQ2B20-PS	
25	CQ2B25-PS	
32	CQ2B32-PS	
40	CQ2B40-PS	
50	CQ2B50-PS	
63	CQ2B63-PS	
80	CQ2B80-PS	
100	CQ2B100-PS	

* Seal kit includes ⑧, ⑨, ⑩. Order the seal kit based on each bore size.
 * The seal kit does not include a grease pack, order it separately.
Grease pack part no.: GR-S-010 (10 g)

Replacement Parts/Seal Kit (Air-hydro type)

Bore size (mm)	Kit no.	Contents
20	CQ2BH20-PS	Kits include items ⑧, ⑨, ⑩ from the table.
25	CQ2BH25-PS	
32	CQ2BH32-PS	
40	CQ2BH40-PS	
50	CQ2BH50-PS	
63	CQ2BH63-PS	
80	CQ2BH80-PS	
100	CQ2BH100-PS	

* Seal kit includes ⑧, ⑨, ⑩. Order the seal kit based on each bore size.
 * The seal kit does not include a grease pack, order it separately.
Grease pack part no.: GR-S-010 (10 g)

- Standard
- Single Acting
- Double Rod
- Axial Piping
- Water Resistant
- High Lateral Load
- End Lock
- Clean Series
- Copper/Fluorine free series
- Construction and Parts
- Warranty and Operating Instructions
- Mounting and Auto Switches
- Made to Order

Construction

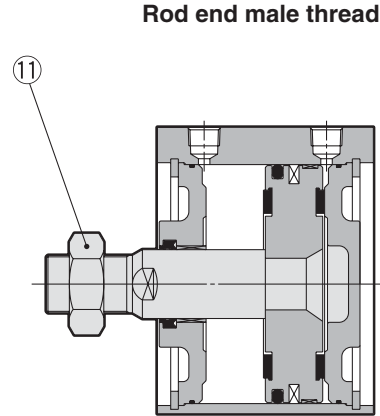
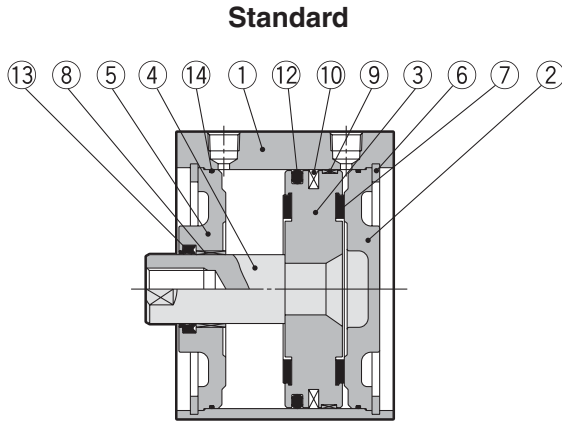

Component Parts

No.	Description	Material	Note
1	Cylinder tube	Aluminum alloy	Hard anodized
2	Head cover	Carbon steel	Nickel plated
3	Piston	Aluminum alloy	Chromated
4	Piston rod	Carbon steel	Hard chrome plated
5	Rod cover	Carbon steel	Nickel plated
6	Retaining ring	Carbon tool steel	Phosphate coated
7	Bumper	Urethane	
8	Bushing	Bearing alloy	
9	Wear ring	Resin	
10	Magnet	-	For CDQ2B □ only
11	Rod end nut	Carbon steel	Nickel plated
12	Piston seal	NBR	
13	Rod seal	NBR	
14	Tube gasket	NBR	

Replacement Parts/Seal Kit

Bore size (mm)	Kit no.	Contents
125	CQ2B125-PS	Kits include items ⑫, ⑬, ⑭ from the table.
140	CQ2B140-PS	
160	CQ2B160-PS	
180	CQ2B180-PS	
200	CQ2B200-PS	

* Seal kit includes ⑫, ⑬, ⑭. Order the seal kit based on each bore size.

* The seal kit does not include a grease pack, order it separately.

Grease pack part no.: GR-S-010 (10 g)

Rod End Nut

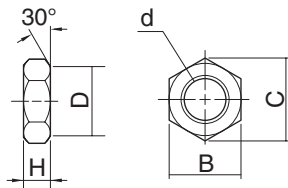

Material: Carbon steel
Surface treatment: Nickel plated

Part no.	Applicable bore size (mm)	d	H	B	C	D
NT-12	125, 140	M30 x 1.5	18	46	53.1	44
NT-16	160, 180, 200	M36 x 1.5	21	55	63.5	53

Construction

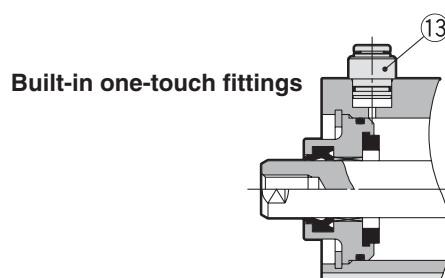
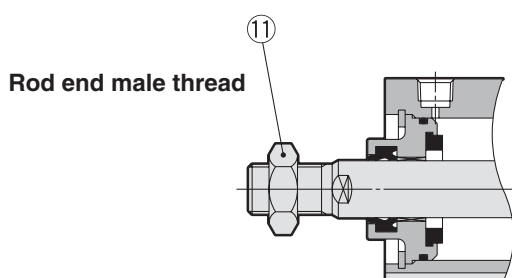
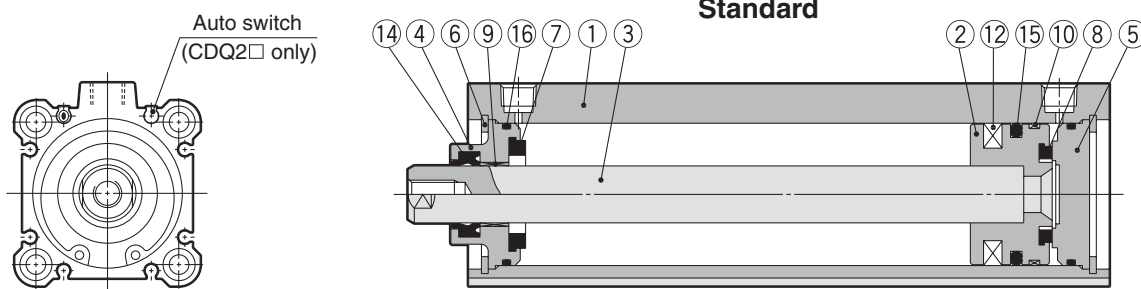

Component Parts

No.	Description	Material	Note
1	Cylinder tube	Aluminum alloy	Hard anodized
2	Piston	Aluminum alloy	Chromated
3	Piston rod	Carbon steel	Hard chrome plated
4	Collar	Aluminum alloy	Anodized
5	Bottom plate	Aluminum alloy	Anodized
6	Retaining ring	Carbon tool steel	Phosphate coated
7	Bumper A	Urethane	
8	Bumper B	Urethane	
9	Bushing	Bearing alloy	
10	Wear ring	Resin	
11	Rod end nut	Carbon steel	Nickel plated
12	Magnet	—	For CDQ2A□ only
13	One-touch fitting	—	ø32 to ø63
14*	Rod seal	NBR	
15*	Piston seal	NBR	
16*	Tube gasket	NBR	

Replacement Parts/Seal Kit

Bore size (mm)	Kit no.	Contents
32	CQ2A32-L-PS	Kits include items 14, 15, 16 from the table.
40	CQ2A40-L-PS	
50	CQ2A50-L-PS	
63	CQ2A63-L-PS	
80	CQ2A80-L-PS	
100	CQ2A100-L-PS	

* Seal kit includes 14, 15, 16. Order the seal kit based on each bore size.

* The seal kit does not include a grease pack, order it separately.

Grease pack part no.: GR-S-010 (10 g)

Standard

Single Acting

Double Rod

Axial Piping

Water Resistant

High Lateral Load

End Lock

Clean Series

Copper/Fluorine free series

Construction and Parts

Warranty and Operating Instructions

Mounting and Auto Switches

Made to Order

Construction

Standard (ø12 to ø32)

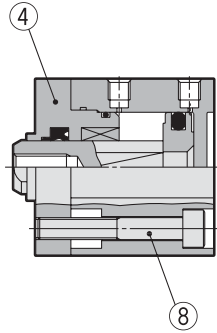

Standard (ø40 to ø63)

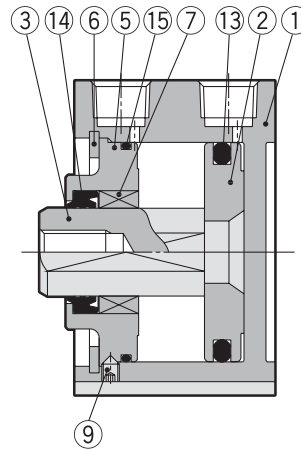

Built-in one-touch fittings

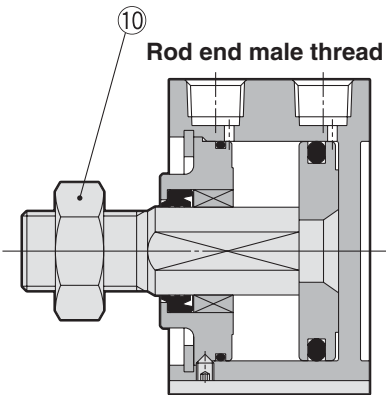
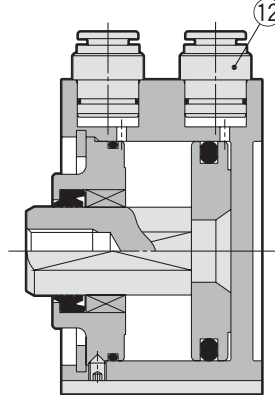
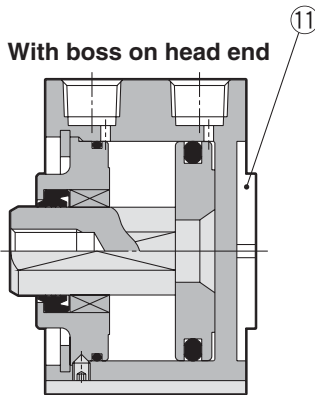

Component Parts

No.	Description	Material	Note
1	Cylinder tube	Aluminum alloy	Hard anodized
2	Piston	Aluminum alloy	Chromated
3	Piston rod	Stainless steel	ø12 to ø25
		Carbon steel	ø32 to ø63, Hard chrome plated
4	Rod cover	Brass	ø12, Electroless nickel plated
		Aluminum alloy	ø16 to ø32, Anodized
5	Collar	Aluminum alloy	ø40 to ø63, Anodized
6	Retaining ring	Carbon tool steel	Phosphate coated
7	Bushing	Oil-impregnated sintered alloy	ø16 to ø63
8	Hexagon socket head cap screw	Alloy steel	ø12 to ø32, Nickel plated
9	Hexagon socket head cap screw	Alloy steel	ø40 to ø63, Nickel plated
10	Rod end nut	Carbon steel	Nickel plated
11	Centering location ring	Aluminum alloy	ø20 to ø63, Anodized
12	One-touch fitting	—	ø32 to ø63
13	Piston seal	NBR	
14	Rod seal	NBR	
15	Tube gasket	NBR	

Replacement Parts/Seal Kit

Bore size (mm)	Kit no.	Contents
12	CQ2KB12-PS	Kits include items 13, 14, 15 from the table.
16	CQ2KB16-PS	
20	CQ2KB20-PS	
25	CQ2KB25-PS	
32	CQ2KB32-PS	
40	CQ2KB40-PS	
50	CQ2KB50-PS	
63	CQ2KB63-PS	

* Seal kit includes 13, 14, 15. Order the seal kit based on each bore size.

* The seal kit does not include a grease pack, order it separately.

Grease pack part no.: GR-S-010 (10 g)

Construction

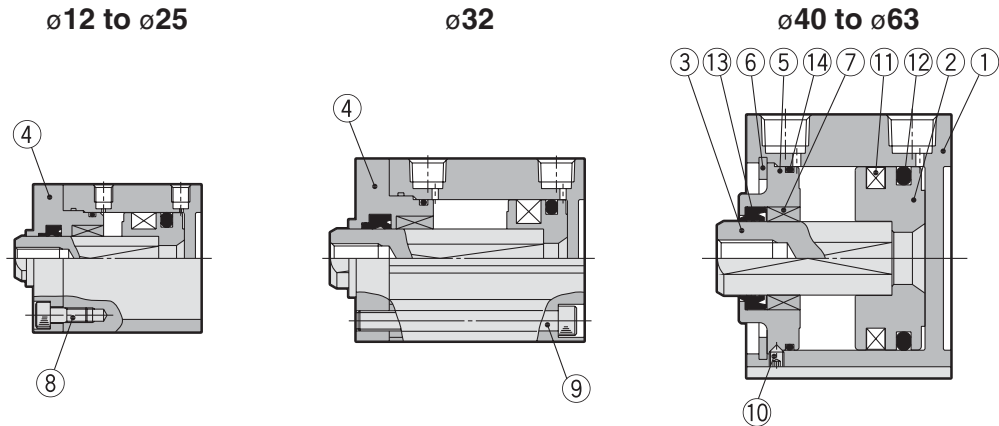

Component Parts

No.	Description	Material	Note
1	Cylinder tube	Aluminum alloy	Hard anodized
2	Piston	Aluminum alloy	Chromated
3	Piston rod	Stainless steel	ø12 to ø25
		Carbon steel	ø32 to ø63, Hard chrome plated
4	Rod cover	Brass	ø12, Electroless nickel plated
		Aluminum alloy	ø16 to ø32, Anodized
5	Collar	Aluminum alloy	ø40 to ø63, Anodized
6	Retaining ring	Carbon tool steel	Phosphate coated
7	Bushing	Oil-impregnated sintered alloy	ø16 to ø63
8	Hexagon socket head cap screw	Alloy steel	ø12 to ø25, Nickel plated
9	Hexagon socket head cap screw	Alloy steel	ø32, Nickel plated
10	Hexagon socket head cap screw	Alloy steel	ø40 to ø63, Nickel plated
11	Magnet	-	
12	Piston seal	NBR	
13	Rod seal	NBR	
14	Tube gasket	NBR	

Replacement Parts/Seal Kit (Pneumatic type (Non-lube))

Bore size (mm)	Kit no.	Contents
12	CQ2KB12-PS	Kits include items ⑫, ⑬, ⑭ from the table.
16	CQ2KB16-PS	
20	CQ2KB20-PS	
25	CQ2KB25-PS	
32	CQ2KB32-PS	
40	CQ2KB40-PS	
50	CQ2KB50-PS	
63	CQ2KB63-PS	

* Seal kit includes ⑫, ⑬, ⑭. Order the seal kit based on each bore size.
 * The seal kit does not include a grease pack, order it separately.
Grease pack part no.: GR-S-010 (10 g)

Standard

Single Acting

Double Rod

Axial Piping

Water Resistant

High Lateral Load

End Lock

Clean Series

Copper/Fluorine free series

Construction and Parts

Warranty and Operating Instructions

Mounting and Auto Switches

Made to Order

Construction

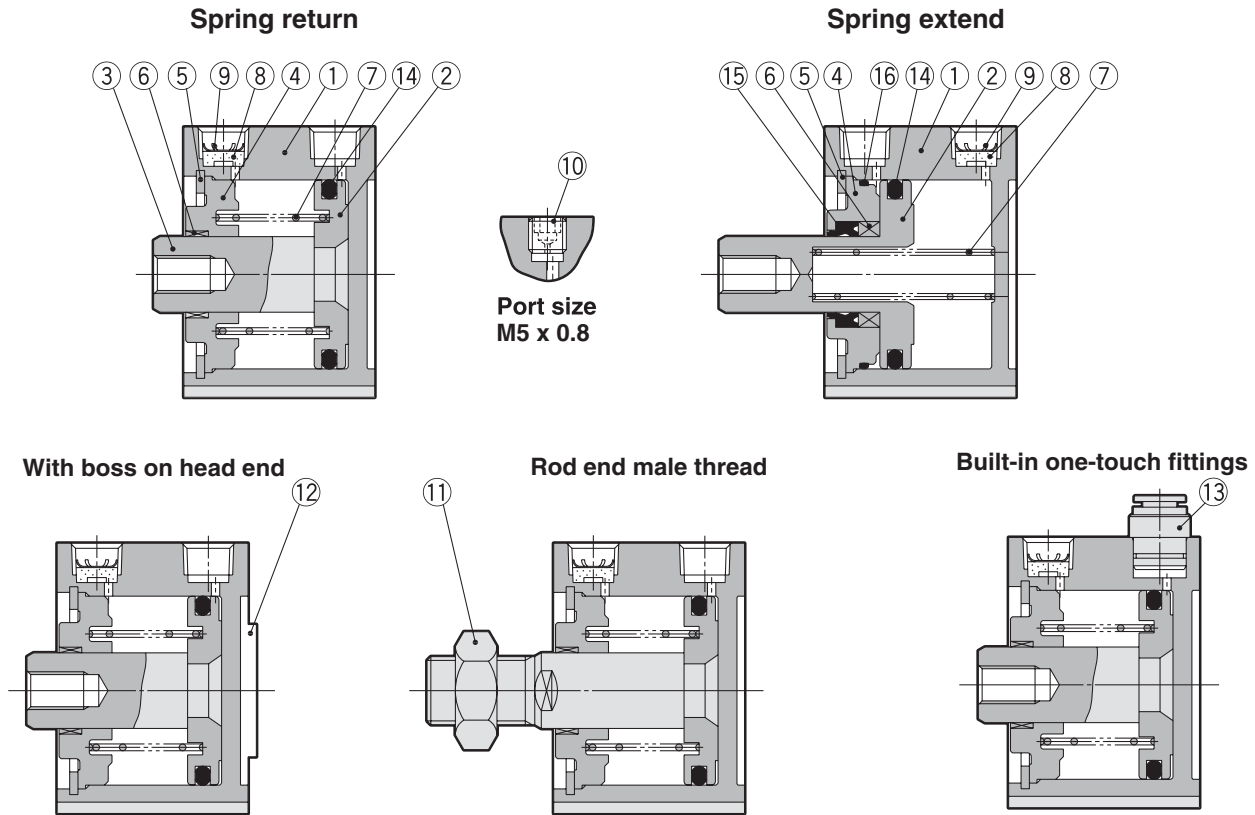

Component Parts

No.	Description	Material	Note
1	Cylinder tube	Aluminum alloy	Hard anodized
2*	Piston	Aluminum alloy	Chromated
3	Piston rod	Stainless steel	ø12 to ø25
		Carbon steel	ø32 to ø50, Hard chrome plated
4	Collar	Aluminum alloy	ø12 to ø40, Anodized
		Aluminum alloy cast	ø50, Chromated, Painted
5	Retaining ring	Carbon tool steel	Phosphate coated
6	Bushing	Bearing alloy	ø50
7	Return spring	Piano wire	Zinc plated
8	Bronze element	Sintered metallic BC	Port size Rc 1/8, 1/4
9	Retaining ring	Carbon tool steel	
10	Plug with fixed orifice	Alloy steel	Port size M5 x 0.8
11	Rod end nut	Carbon steel	Nickel plated
12	Centering location ring	Aluminum alloy	ø20 to ø50, Anodized
13	One-touch fitting	-	ø32 to ø50

* On spring extend (Type T), piston and piston rod are integrated (stainless steel). Except ø12 and ø16 of built-in magnet type.

Replacement Parts

No.	Description	Material	Note
14	Piston seal	NBR	
15	Rod seal	NBR	
16	Gasket	NBR	

Replacement Parts/Seal Kit

Bore size (mm)	Single acting/Spring return	Single acting/Spring extend
12	CQ2B12-S-PS	CQ2B12-T-PS
16	CQ2B16-S-PS	CQ2B16-T-PS
20	CQ2B20-S-PS	CQ2B20-T-PS
25	CQ2B25-S-PS	CQ2B25-T-PS
32	CQ2B32-S-PS	CQ2B32-T-PS
40	CQ2B40-S-PS	CQ2B40-T-PS
50	CQ2B50-S-PS	CQ2B50-T-PS
Contents	Kits include item 14 from the above table	Kits include 14, 15, 16 from the above table.
How to Order	* Seal kit includes 14. Order the seal kit based on each bore size.	* Seal kit includes 14, 15, 16. Order the seal kit based on each bore size.

* The seal kit does not include a grease pack, order it separately.
Grease pack part number: GR-S-010 (10g)

Construction

Spring return

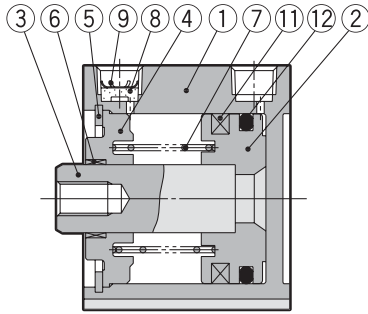

Spring extend

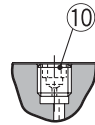
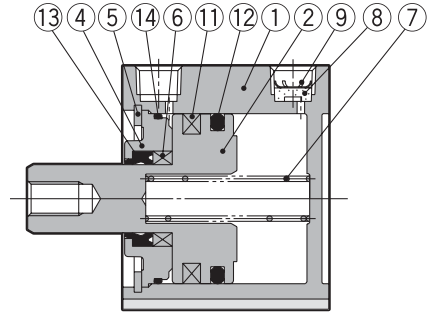

Port size
M5 x 0.8

Component Parts

No.	Description	Material	Note
1	Cylinder tube	Aluminum alloy	Hard anodized
2	Piston	Aluminum alloy	Chromated
3	Piston rod	Stainless steel	ø12 to ø25
		Carbon steel	ø32 to ø50, Hard chrome plated
4	Collar	Aluminum alloy	ø12 to ø40, Anodized
		Aluminum alloy cast	ø50, Chromated, Painted
5	Retaining ring	Carbon tool steel	Phosphate coated
6	Bushing	Bearing alloy	ø50
7	Return spring	Piano wire	Zinc chromated
8	Bronze element	Sintered metallic BC	Port size Rc1/8, 1/4
9	Retaining ring	Carbon tool steel	
10	Plug w/ fixed orifice	Alloy steel	Port size M5 x 0.8
11	Magnet	-	

No.	Description	Material	Note
12	Piston seal	NBR	
13	Rod seal	NBR	
14	Gasket	NBR	

Replacement Parts/Seal Kit

Same as for standard, single acting, single rod - refer to page 132.

* On spring extend (Type T), piston with ø20 or more and piston rod are integrated (stainless steel).

Standard

Single Acting

Double Rod

Axial Piping

Water Resistant

High Lateral Load

End Lock

Clean Series

Copper/Fluorine free series

Construction and Parts

Warranty and Operating Instructions

Mounting and Auto Switches

Made to Order

Construction

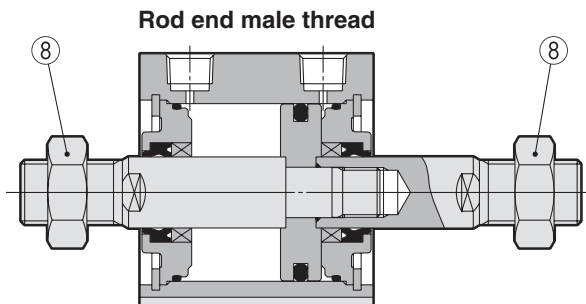
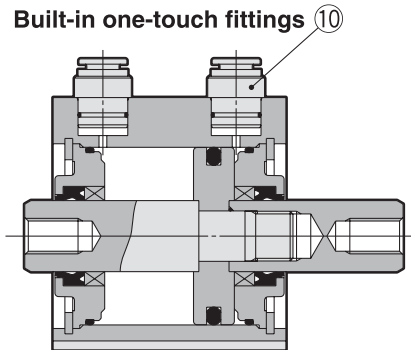
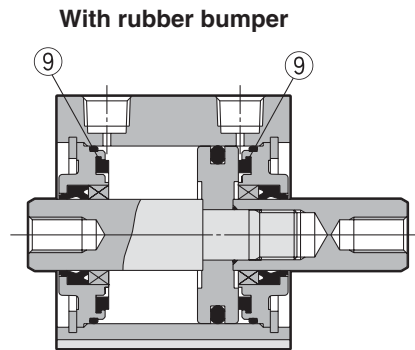
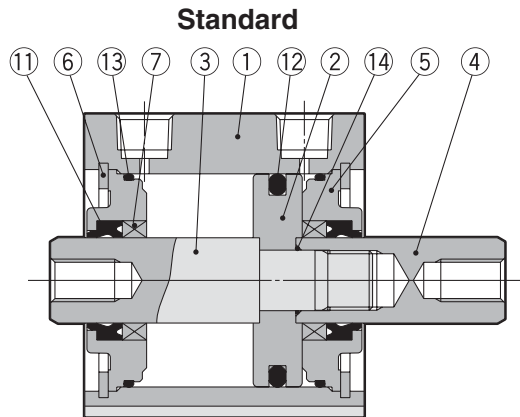

Component Parts

No.	Description	Material	Note
1	Cylinder tube	Aluminum alloy	Hard anodized
2	Piston	Aluminum alloy	Chromated
3	Piston rod A	Stainless steel	ø12 to ø25
		Carbon steel	ø32 to ø100, Hard chrome plated
4	Piston rod B	Stainless steel	ø12 to ø25
		Carbon steel	ø32 to ø100, Hard chrome plated
5	Collar	Aluminum alloy	ø12 to ø40, Anodized
		Aluminum alloy cast	ø50 to ø100, Chromated, Painted
6	Retaining ring	Carbon tool steel	Phosphate coated
7	Bushing	Bearing alloy	For ø50 or more only
8	Rod end nut	Carbon steel	Nickel plated
9	Bumper	Urethane	
10	One-touch fitting	-	ø32 to ø63
11*	Rod seal	NBR	
12*	Piston seal	NBR	
13*	Tube gasket	NBR	
14	Piston gasket	NBR	

Replacement Parts/Seal Kit (Pneumatic type)

Bore size (mm)	Kit no.	Contents
12	CQ2WB12-PS	Kits include items 11, 12, 13 from the table.
16	CQ2WB16-PS	
20	CQ2WB20-PS	
25	CQ2WB25-PS	
32	CQ2WB32-PS	
40	CQ2WB40-PS	
50	CQ2WB50-PS	
63	CQ2WB63-PS	
80	CQ2WB80-PS	
100	CQ2WB100-PS	

* Seal kit includes 11, 12, 13. Order the seal kit based on each bore size.
 * The seal kit does not include a grease pack, order it separately.
Grease pack part no.: GR-S-010 (10 g)

Replacement Parts/Seal Kit (Air-hydro type)

Bore size (mm)	Kit no.	Contents
20	CQ2WBH20-PS	Kits include items 11, 12, 13 from the table.
25	CQ2WBH25-PS	
32	CQ2WBH32-PS	
40	CQ2WBH40-PS	
50	CQ2WBH50-PS	
63	CQ2WBH63-PS	
80	CQ2WBH80-PS	
100	CQ2WBH100-PS	

* Seal kit includes 11, 12, 13. Order the seal kit based on each bore size.
 * The seal kit does not include a grease pack, order it separately.
Grease pack part no.: GR-S-010 (10 g)

Construction

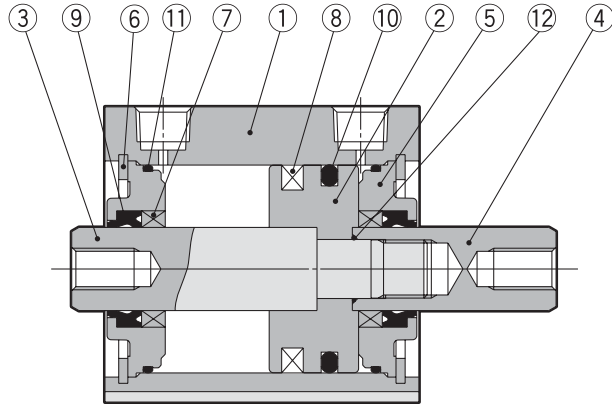

Component Parts

No.	Description	Material	Note
1	Cylinder tube	Aluminum alloy	Hard anodized
2	Piston	Aluminum alloy	Chromated
3	Piston rod A	Stainless steel	ø12 to ø25
		Carbon steel	ø32 to ø100, Hard chrome plated
4	Piston rod B	Stainless steel	ø12 to ø25
		Carbon steel	ø32 to ø100, Hard chrome plated
5	Collar	Aluminum alloy	ø12 to ø40, Anodized
		Aluminum alloy cast	ø50 to ø100, Chromated, Painted
6	Retaining ring	Carbon tool steel	Phosphate coated
7	Bushing	Bearing alloy	For ø50 or more only
8	Magnet	-	
9*	Rod seal	NBR	
10*	Piston seal	NBR	
11*	Tube gasket	NBR	
12	Piston gasket	NBR	

Replacement Parts/Seal Kit (Pneumatic type)

Bore size (mm)	Kit no.	Contents
12	CQ2WB12-PS	Kits include items 9, 10, 11 from the table.
16	CQ2WB16-PS	
20	CQ2WB20-PS	
25	CQ2WB25-PS	
32	CQ2WB32-PS	
40	CQ2WB40-PS	
50	CQ2WB50-PS	
63	CQ2WB63-PS	
80	CQ2WB80-PS	
100	CQ2WB100-PS	

Replacement Parts/Seal Kit (Air-hydro type)

Bore size (mm)	Kit no.	Contents
20	CQ2WBH20-PS	Kits include items 9, 10, 11 from the table.
25	CQ2WBH25-PS	
32	CQ2WBH32-PS	
40	CQ2WBH40-PS	
50	CQ2WBH50-PS	
63	CQ2WBH63-PS	
80	CQ2WBH80-PS	
100	CQ2WBH100-PS	

* Seal kit includes 9, 10, 11. Order the seal kit based on each bore size.
 * The seal kit does not include a grease pack, order it separately.
Grease pack part no.: GR-S-010 (10 g)

* Seal kit includes 9, 10, 11. Order the seal kit based on each bore size.
 * The seal kit does not include a grease pack, order it separately.
Grease pack part no.: GR-S-010 (10 g)

Standard

Single Acting

Double Rod

Axial Piping

Water Resistant

High Lateral Load

End Lock

Clean Series

Copper/Fluorine free series

Construction and Parts

Warranty and Operating Instructions

Mounting and Auto Switches

Made to Order

Construction

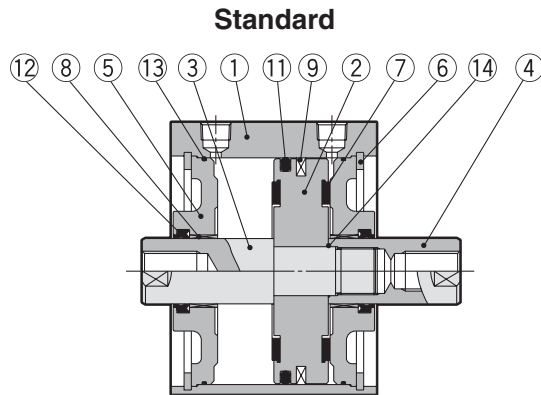

Rod end male thread

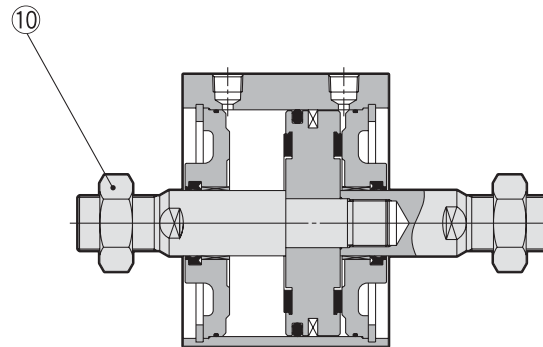

Component Parts

No.	Description	Material	Note
1	Cylinder tube	Aluminum alloy	Hard anodized
2	Piston	Aluminum alloy	Chromated
3	Piston rod A	Carbon steel	Hard chrome plated
4	Piston rod B	Carbon steel	Hard chrome plated
5	Rod cover	Carbon steel	Nickel plated
6	Retaining ring	Carbon tool steel	Phosphate coated
7	Bumper	Resin	
8	Bushing	Bearing alloy	
9	Magnet	—	For CDQ2WB□ only
10	Rod end nut	Carbon steel	Nickel plated
11	Piston seal	NBR	
12	Rod seal	NBR	
13	Tube gasket	NBR	
14	Piston gasket	NBR	

Replacement Parts/Seal Kit

Bore size (mm)	Kit no.	Contents
125	CQ2WB125-PS	Kits include items ①, ②, ⑬ from the table.
140	CQ2WB140-PS	
160	CQ2WB160-PS	
180	CQ2WB180-PS	
200	CQ2WB200-PS	

* Seal kit includes ①, ②, ⑬. Order the seal kit based on each bore size.

* The seal kit does not include a grease pack, order it separately.

Grease pack part no.: GR-S-010 (10 g)

Rod End Nut

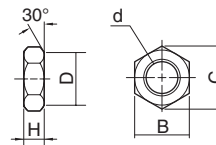

Material: Carbon steel
Surface treatment: Nickel plated

Part no.	Applicable bore size (mm)	d	H	B	C	D
NT-12	125, 140	M30 x 1.5	18	46	53.1	44
NT-16	160, 180, 200	M36 x 1.5	21	55	63.5	53

Construction

Standard (ø12 to ø32)

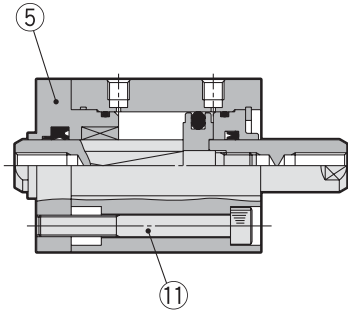

Standard (ø40 to ø63)

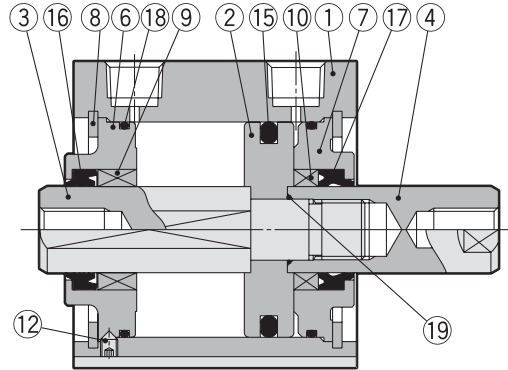

Built-in one-touch fittings

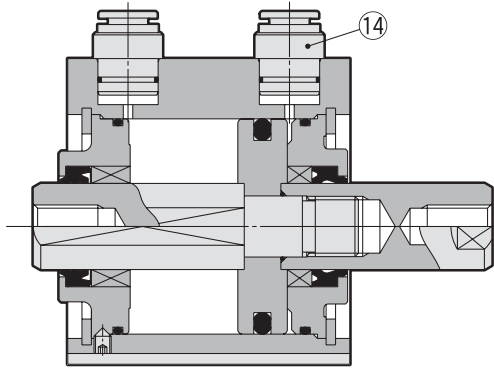

Rod end male thread

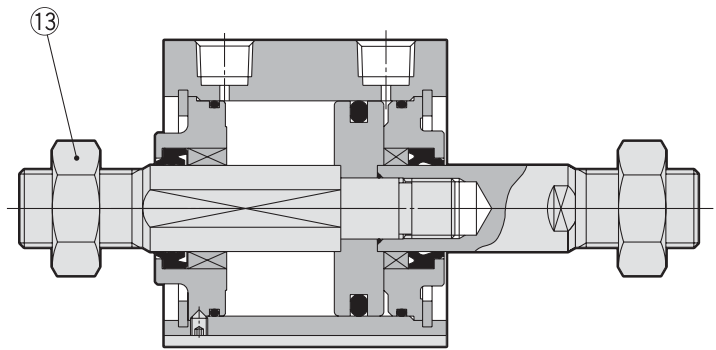

Component Parts

No.	Description	Material	Note
1	Cylinder tube	Aluminum alloy	Hard anodized
2	Piston	Aluminum alloy	Chromated
3	Piston rod A	Stainless steel	ø12 to ø25
		Carbon steel	ø32 to ø63, Hard chrome plated
4	Piston rod B	Stainless steel	ø12 to ø25
		Carbon steel	ø32 to ø63, Hard chrome plated
5	Rod cover	Brass	ø12, Electroless nickel plated
		Aluminum alloy	ø16 to ø32, Anodized
6	Collar for non-rotating	Aluminum alloy	ø40 to ø63, Anodized
7	Collar	Aluminum alloy	ø12 to ø40, Anodized
		Aluminum alloy cast	ø50 to ø63, Chromated, painted
8	Retaining ring	Carbon tool steel	Phosphate coated
9	Bushing for Non-rotating	Oil-impregnated sintered alloy	ø16 to ø63
10	Bushing	Bearing alloy	ø50 to ø63
11	Hexagon socket head cap screw	Alloy steel	ø12 to ø32, Nickel plated
12	Hexagon socket head cap screw	Alloy steel	ø40 to ø63, Nickel plated

No.	Description	Material	Note
13	Rod end nut	Carbon steel	Nickel plated
14	One-touch fitting	—	ø32 to ø63
15	Piston seal	NBR	
16	Rod seal for Non-rotating	NBR	
17	Rod seal	NBR	
18	Gasket	NBR	
19	Piston gasket	NBR	ø32 to ø63

Replacement Parts/Seal Kit

Bore size (mm)	Kit no.	Contents
12	CQ2KWB12-PS	Kits include items 15, 16, 17, 18 from the table.
16	CQ2KWB16-PS	
20	CQ2KWB20-PS	
25	CQ2KWB25-PS	
32	CQ2KWB32-PS	
40	CQ2KWB40-PS	
50	CQ2KWB50-PS	
63	CQ2KWB63-PS	

* Seal kit includes 15, 16, 17, 18. Order the seal kit based on each bore size.
 * The seal kit does not include a grease pack, order it separately.

Grease pack part no.: GR-S-010 (10 g)

Standard

Single Acting

Double Rod

Axial Piping

Water Resistant

High Lateral Load

End Lock

Clean Series

Copper/Fluorine free series

Construction and Parts

Warranty and Operating Instructions

Mounting and Auto Switches

Made to Order

Construction

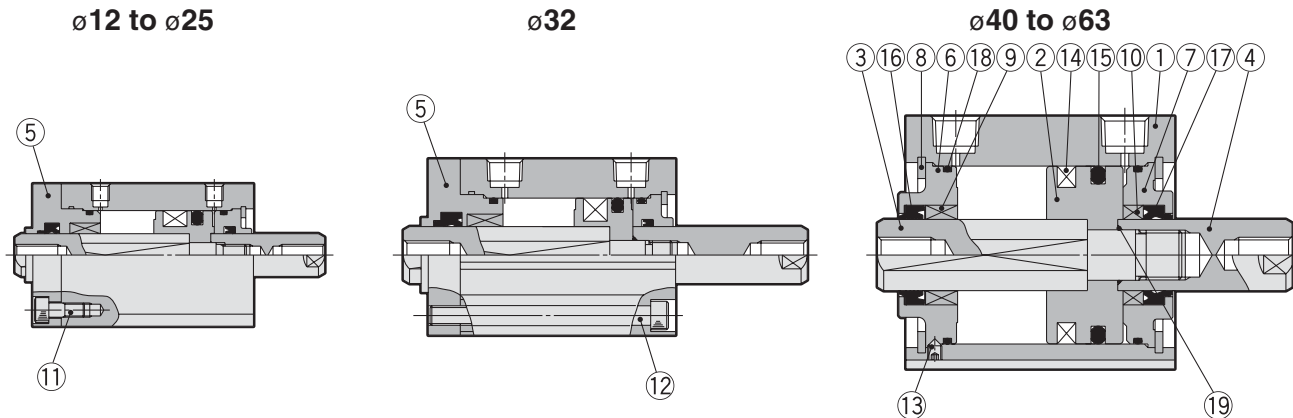

Component Parts

No.	Description	Material	Note
1	Cylinder tube	Aluminum alloy	Hard anodized
2	Piston	Aluminum alloy	Chromated
3	Piston rod A	Stainless steel	ø12 to ø25
		Carbon steel	ø32 to ø63, Hard chrome plated
4	Piston rod B	Stainless steel	ø12 to ø25
		Carbon steel	ø32 to ø63, Hard chrome plated
5	Rod cover	Brass	ø12, Electroless nickel plated
		Aluminum alloy	ø16 to ø32, Anodized
6	Collar for non-rotating	Aluminum alloy	ø40 to ø63, Anodized
7	Collar	Aluminum alloy	ø12 to ø40, Anodized
		Aluminum alloy cast	ø50 to ø63, Chromated, painted
8	Retaining ring	Carbon tool steel	Phosphate coated
9	Bushing for Non-rotating	Oil-impregnated sintered alloy	ø16 to ø63
10	Bushing	Bearing alloy	ø50 to ø63
11	Hexagon socket head cap screw	Alloy steel	ø12 to ø25, Nickel plated
12	Hexagon socket head cap screw	Alloy steel	ø32, Nickel plated
13	Hexagon socket head set screw	Alloy steel	ø40 to ø63, Nickel plated
14	Magnet	-	
15	Piston seal	NBR	
16	Rod seal for non-rotating	NBR	
17	Rod seal	NBR	
18	Gasket	NBR	
19	Piston gasket	NBR	ø32 to ø63

Replacement Parts/Seal Kit

Bore size (mm)	Kit no.	Contents
12	CQ2KWB12-PS	Kits include items 15, 16, 17, 18 from the table.
16	CQ2KWB16-PS	
20	CQ2KWB20-PS	
25	CQ2KWB25-PS	
32	CQ2KWB32-PS	
40	CQ2KWB40-PS	
50	CQ2KWB50-PS	
63	CQ2KWB63-PS	

* Seal kit includes 15, 16, 17, 18. Order the seal kit based on each bore size.

* The seal kit does not include a grease pack, order it separately.

Grease pack part no.: GR-S-010 (10 g)

Construction

Standard

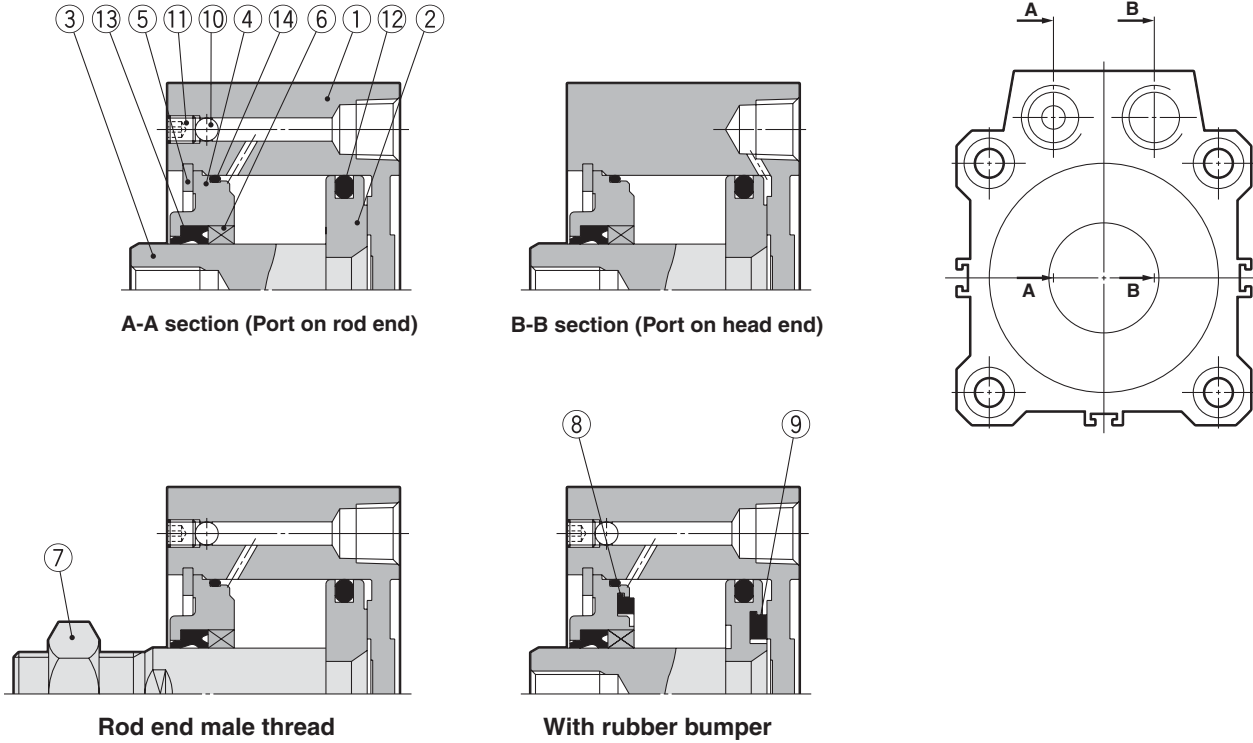

Component Parts

No.	Description	Material	Note
1	Cylinder tube	Aluminum alloy	Hard anodized
2	Piston	Aluminum alloy	Chromated
3	Piston rod	Stainless steel	ø12 to ø25
		Carbon steel	ø32 to ø63, Hard chrome plated
4	Collar	Aluminum alloy	ø12 to ø40, Anodized
		Aluminum alloy cast	ø50 to ø63, Chromated, painted
5	Collar	Aluminum alloy	ø40 to ø63, Anodized
6	Retaining ring	Carbon tool steel	Phosphate coated
7	Bushing	Bearing alloy	ø50 to ø100
8	Rod end nut	Carbon steel	Nickel plated
9	Bumper A	Urethane	
10	Bumper B	Urethane	
11	Steel ball	Carbon steel	
12	Hexagon socket head cap screw	Alloy steel	Nickel plated
13	Piston seal	NBR	
14	Rod seal	NBR	
15	Gasket	NBR	

Replacement Parts/Seal Kit

Bore size (mm)	Kit no.		Contents
	Pneumatic type (Non-lube)	Air-hydro type	
12	CQ2B12-PS	—	Kits include items 12, 13, 14 from the table.
16	CQ2B16-PS	—	
20	CQ2B20-PS	CQ2BH20-PS	
25	CQ2B25-PS	CQ2BH25-PS	
32	CQ2B32-PS	CQ2BH32-PS	
40	CQ2B40-PS	CQ2BH40-PS	
50	CQ2B50-PS	CQ2BH50-PS	
63	CQ2B63-PS	CQ2BH63-PS	
80	CQ2B80-PS	CQ2BH80-PS	
100	CQ2B100-PS	CQ2BH100-PS	

* Seal kit includes 12, 13, 14. Order the seal kit based on each bore size.
* The seal kit does not include a grease pack, order it separately.

Grease pack part no.: GR-S-010 (10 g)

Standard
Single Acting
Double Rod
Axial Piping
Water Resistant
High Lateral Load
End Lock
Clean Series
Copper/Fluorine free series
Construction and Parts
Warranty and Operating Instructions
Mounting and Auto Switches
Made to Order

Construction

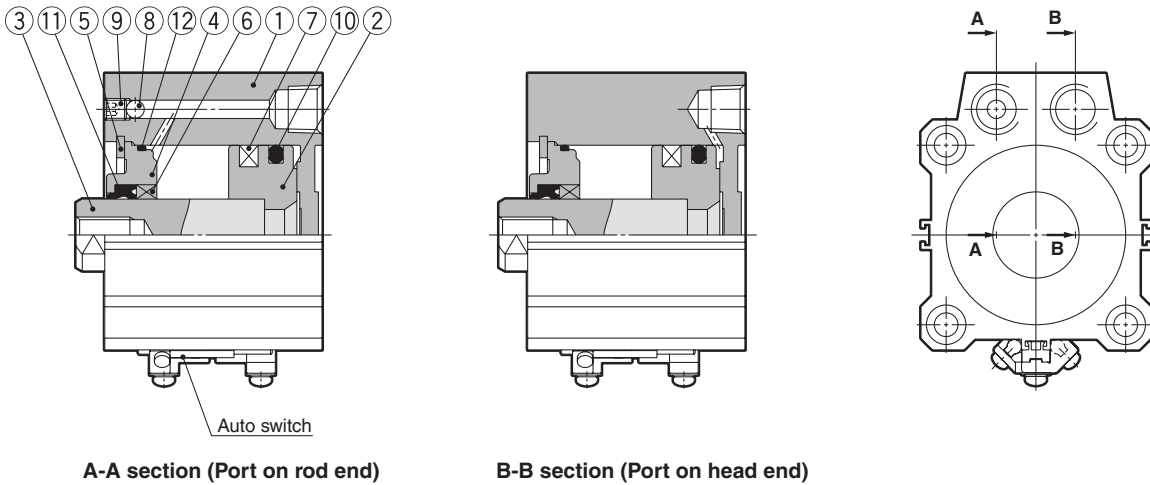

Component Parts

No.	Description	Material	Note
1	Cylinder tube	Aluminum alloy	Hard anodized
2	Piston	Aluminum alloy	Chromated
3	Piston rod	Stainless steel	ø12 to ø25
		Carbon steel	ø32 to ø100, Hard chrome plated
4	Collar	Aluminum alloy	ø12 to ø40, Anodized
		Aluminum alloy cast	ø50 to ø100, Chromated, painted
5	Retaining ring	Carbon tool steel	Phosphate coated
6	Bushing	Bearing alloy	ø50 to ø100
7	Magnet	—	
8	Steel ball	Carbon steel	
9	Hexagon socket head cap screw	Alloy steel	Nickel plated
10	Piston seal	NBR	
11	Rod seal	NBR	
12	Gasket	NBR	

Replacement Parts/Seal Kit

Bore size (mm)	Kit no.		Contents
	Pneumatic type (Non-lube)	Air-hydro type	
12	CQ2B12-PS	—	Kits include items ⑩, ⑪, ⑫ from the table.
16	CQ2B16-PS	—	
20	CQ2B20-PS	CQ2BH20-PS	
25	CQ2B25-PS	CQ2BH25-PS	
32	CQ2B32-PS	CQ2BH32-PS	
40	CQ2B40-PS	CQ2BH40-PS	
50	CQ2B50-PS	CQ2BH50-PS	
63	CQ2B63-PS	CQ2BH63-PS	
80	CQ2B80-PS	CQ2BH80-PS	
100	CQ2B100-PS	CQ2BH100-PS	

* Seal kit includes ⑩, ⑪, ⑫. Order the seal kit based on each bore size.

* The seal kit does not include a grease pack, order it separately.

Grease pack part no.: GR-S-010 (10 g)

Construction

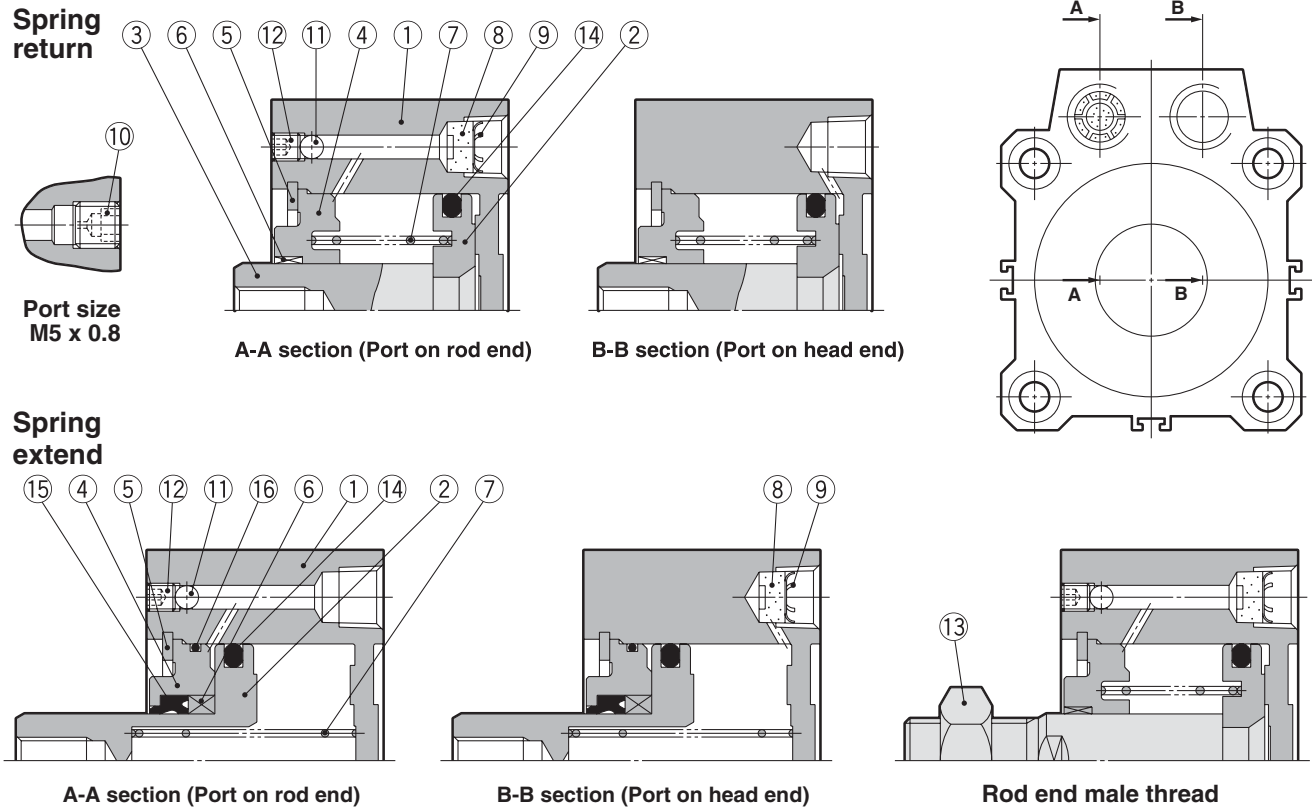

Component Parts

No.	Description	Material	Note
1	Cylinder tube	Aluminum alloy	Hard anodized
2*	Piston	Aluminum alloy	Chromated
3	Piston rod	Stainless steel	ø12 to ø25
		Carbon steel	ø32 to ø100, Hard chrome plated
4	Collar	Aluminum alloy	ø12 to ø40, Anodized
		Aluminum alloy cast	ø50 to ø100, Chromated, painted
5	Retaining ring	Carbon tool steel	Phosphate coated
6	Bushing	Bearing alloy	ø50 to ø100
7	Return spring	Piano wire	Zinc chromated
8	Bronze element	Sintered metallic BC	Port size Rc1/8, 1/4
9	Retaining ring	Carbon tool steel	
10	Plug with fixed orifice	Alloy steel	Port size M5 x 0.8
11	Steel ball	Carbon steel	
12	Hexagon socket head cap screw	Alloy steel	Nickel plated
13	Rod end nut	Carbon steel	Nickel plated
14	Piston seal	NBR	
15	Rod seal	NBR	
16	Gasket	NBR	

* On spring extend (Type T), piston and piston rod are integrated (stainless steel).

Replacement Parts/Seal Kit

Bore size (mm)	Kit no. (Single acting/Spring return)	Kit no. (Single acting/Spring extend)
12	CQ2B12-S-PS	CQ2B12-T-PS
16	CQ2B16-S-PS	CQ2B16-T-PS
20	CQ2B20-S-PS	CQ2B20-T-PS
25	CQ2B25-S-PS	CQ2B25-T-PS
32	CQ2B32-S-PS	CQ2B32-T-PS
40	CQ2B40-S-PS	CQ2B40-T-PS
50	CQ2B50-S-PS	CQ2B50-T-PS
Contents	Kits includes item 14 from the above table	Kits include 14, 15, 16 from the above table.
How to Order	* Seal kit includes 14. Order the seal kit based on each bore size.	* Seal kit includes 14, 15, 16. Order the seal kit based on each bore size.

* The seal kit does not include a grease pack, order it separately.
Grease pack part no.: GR-S-010 (10 g)

Standard
Single Acting
Double Rod
Axial Piping
Water Resistant
High Lateral Load
End Lock
Clean Series
Copper/Fluorine free series
Construction and Parts
Warranty and Operating Instructions
Mounting and Auto Switches
Made to Order

Construction

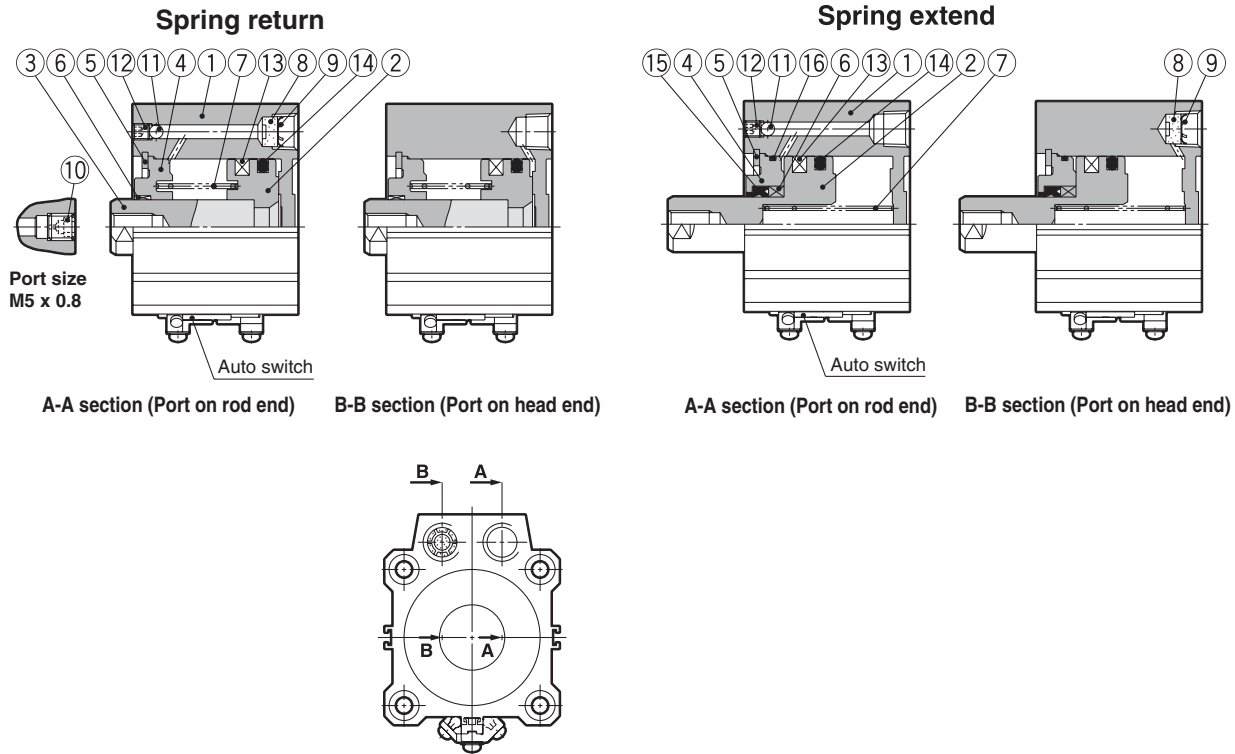

Component Parts

No.	Description	Material	Note
1	Cylinder tube	Aluminum alloy	Hard anodized
2	Piston *	Aluminum alloy	Chromated
3	Piston rod *	Stainless steel	ø12 to ø25
		Carbon steel	ø32 to ø50, Hard chrome plated
4	Collar	Aluminum alloy	ø12 to ø40, Anodized
		Aluminum alloy cast	ø50, Chromate, painted
5	Retaining ring	Carbon tool steel	Phosphate coated
6	Bushing	Bearing alloy	
7	Return spring	Piano wire	Zinc chromated
8	Bronze element	Sintered metallic BC	Port size Rc1/8, 1/4
9	Retaining ring	Carbon tool steel	
10	Plug with fixed orifice	Alloy steel	Port size M5 x 0.8
11	Steel ball	Carbon steel	
12	Hexagon socket head cap screw	Alloy steel	Nickel plated
13	Magnet	-	
14	Piston seal	NBR	
15	Rod seal	NBR	
16	Gasket	NBR	

* On spring extend (Type T), piston and piston rod are integrated (stainless steel).

Replacement Parts/Seal Kit

Bore size (mm)	Kit no. (Single acting/Spring return)	Kit no. (Single acting/Spring extend)
12	CQ2B12-S-PS	CQ2B12-T-PS
16	CQ2B16-S-PS	CQ2B16-T-PS
20	CQ2B20-S-PS	CQ2B20-T-PS
25	CQ2B25-S-PS	CQ2B25-T-PS
32	CQ2B32-S-PS	CQ2B32-T-PS
40	CQ2B40-S-PS	CQ2B40-T-PS
50	CQ2B50-S-PS	CQ2B50-T-PS
Contents	Kits includes item 14 from the above table	Kits include 14, 15, 16 from the above table.
How to Order	* Seal kit includes 14. Order the seal kit based on each bore size.	* Seal kit includes 14, 15, 16. Order the seal kit based on each bore size.

* The seal kit does not include a grease pack, order it separately.
Grease pack part no.: GR-S-010 (10 g)

Construction

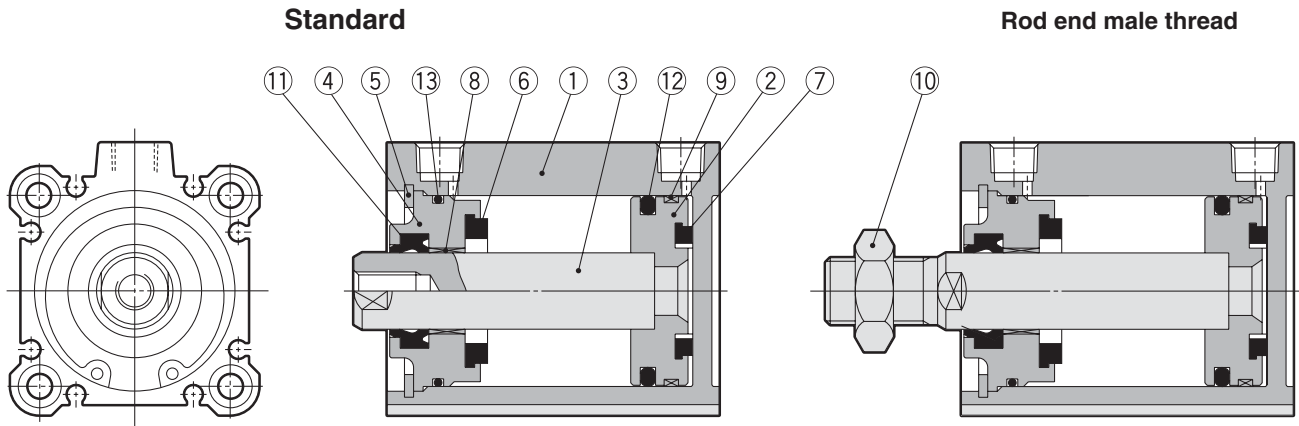

Component Parts

No.	Description	Material	Note
1	Cylinder tube	Aluminum alloy	Hard anodized
2	Piston	Aluminum alloy	Chromated
3	Piston rod	Carbon steel	Hard chrome plated
4	Collar	Aluminum alloy	Anodized
5	Retaining ring	Carbon tool steel	Phosphate coated
6	Bumper A	Urethane	
7	Bumper B	Urethane	
8	Bushing	Bearing alloy	
9	Wear ring	Resin	
10	Rod end nut	Carbon steel	Nickel plated
11	Rod seal	NBR	
12	Piston seal	NBR	
13	Tube gasket	NBR	

Replacement Parts/Seal Kit

Bore size (mm)	Kit no.	Contents
32	CQ2B32-PS	Kits include items ①, ②, ⑬ from the table.
40	CQ2B40-PS	
50	CQ2B50-PS	
63	CQ2B63-PS	
80	CQ2B80-PS	
100	CQ2B100-PS	

* Seal kit includes ①, ②, ⑬. Order the seal kit based on each bore size.
* The seal kit does not include a grease pack, order it separately.
Grease pack part no.: GR-S-010 (10 g)

Standard
Single Acting
Double Rod
Axial Piping
Water Resistant
High Lateral Load
End Lock
Clean Series
Copper/Fluorine free series
Construction and Parts
Warranty and Operating Instructions
Mounting and Auto Switches
Made to Order

Construction

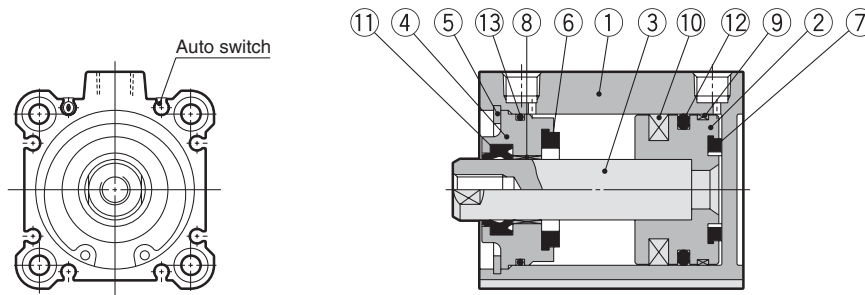

Component Parts

No.	Description	Material	Note
1	Cylinder tube	Aluminum alloy	Hard anodized
2	Piston	Aluminum alloy	Chromated
3	Pistonrod	Carbon steel	Hard chrome plated
4	Collar	Aluminum alloy	Anodized
5	Retaining ring	Carbon tool steel	Phosphate coated
6	Bumper A	Urethane	
7	Bumper B	Urethane	
8	Bushing	Bearing alloy	
9	Wear ring	Resin	
10	Magnet	—	
11	Rod seal	NBR	
12	Piston seal	NBR	
13	Tube gasket	NBR	

Replacement Parts/Seal Kit

Bore size (mm)	Kit no.	Contents
32	CQ2B32-PS	Kits include items ①, ②, ⑬ from the table.
40	CQ2B40-PS	
50	CQ2B50-PS	
63	CQ2B63-PS	
80	CQ2B80-PS	
100	CQ2B100-PS	

* Seal kit includes ①, ②, ⑬. Order the seal kit based on each bore size.

* The seal kit does not include a grease pack, order it separately.

Grease pack part no.: GR-S-010 (10 g)

Construction

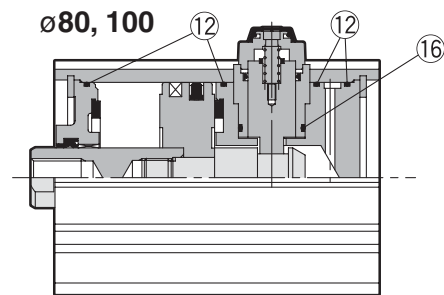
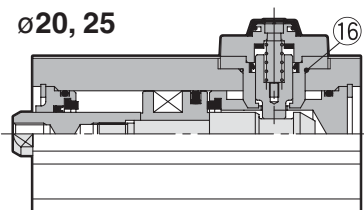
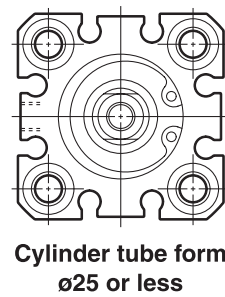
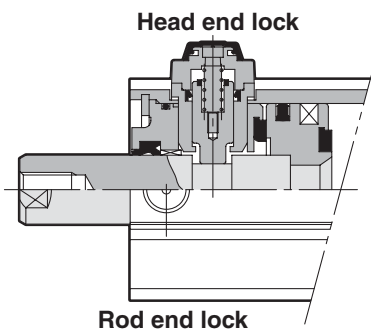
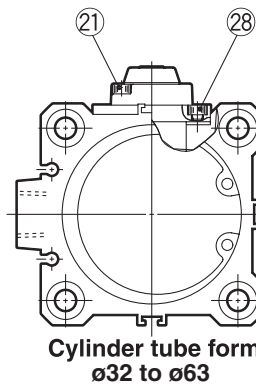
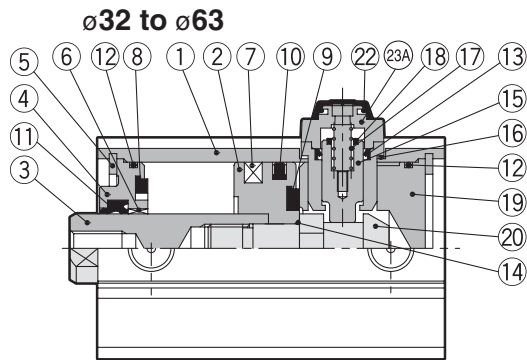

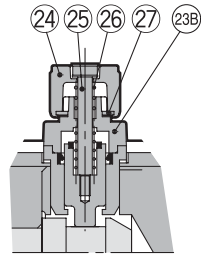

Manual release
(Lock type): Suffix L

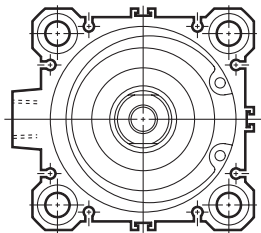

Cylinder tube form
ø80 or more

Component Parts

No.	Description	Material	Note
1	Cylinder tube	Aluminum alloy	Hard anodized
2	Piston	Aluminum alloy	Chromated
3	Piston rod	Carbon steel	Hard chrome plated
4	Collar	R□ Aluminum alloy	Anodized
		H□ Aluminum alloy	ø40 or less, Anodized
		H□ Aluminum alloy cast	ø50 or more, Painted after chromated
5	Retaining ring	Carbon tool steel	Phosphate coated
6	Bushing	R□ Copper alloy	Used for all bore sizes
		H□	Used for ø40 or more
7	Magnet	—	With auto switch
8	Bumper A	Urethane	
9	Bumper B	Urethane	
10	Piston seal	NBR	
11	Rod seal	NBR	
12	Tube gasket	NBR	Using 4 pcs. for ø80, ø100
13	Lock piston seal	NBR	
14	Piston gasket	NBR	Nothing for ø20, ø25
15	Lock piston	Carbon steel	Quenched, Hard chrome plated
16	Gasket	NBR	
17	Lock spring	Stainless steel	
18	Bumper	Urethane	
19	Head cover	Aluminum alloy	Anodized
20	Lock bolt	Carbon steel	Quenched, Electroless nickel plated
21	Hexagon socket head cap screw	Alloy steel	Black zinc chromated
22	Rubber cap	Synthetic rubber	
23A	Cap A	Aluminum casted	Black painted
23B	Cap B	Carbon steel	Oxide film treated
24	M/O knob	Zinc die-casted	Black painted
25	M/O bolt	Alloy steel	Black zinc chromated, Red painted
26	M/O spring	Steel wire	Zinc chromated
27	Stopper ring	Rolled steel	Zinc chromated
28	Hexagon socket head cap screw	Alloy steel	Nickel plated

Replacement Parts/Seal Kit (End lock type)

Bore size (mm)	Kit no.	Contents
20	CBQ2B20-PS	Kits include items ⑩, ⑪, ⑫, ⑬, ⑯, ⑰, ⑱, ⑳ from the table and a grease pack.
25	CBQ2B25-PS	
32	CBQ2B32-PS	
40	CBQ2B40-PS	
50	CBQ2B50-PS	
63	CBQ2B63-PS	
80	CBQ2B80-PS	
100	CBQ2B100-PS	

* Seal kit includes ⑩, ⑪, ⑫, ⑬, ⑯, ⑰, ⑱, ⑳. Order the seal kit based on each bore size.

* The seal kit does not include a grease pack, order it separately.
Grease pack part no.: GR-S-010 (10 g)

Standard

Single Acting

Double Rod

Axial Piping

Water Resistant

High Lateral Load

End Lock

Clean Series

Copper/Fluorine free series

Construction and Parts

Warranty and Operating Instructions

Mounting and Auto Switches

Made to Order

Construction

Standard (ø20 to ø32)

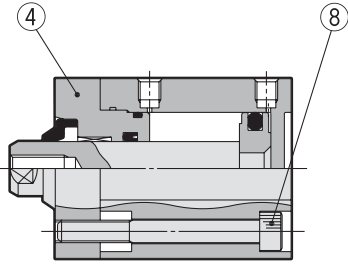

Standard (ø40 to ø100)

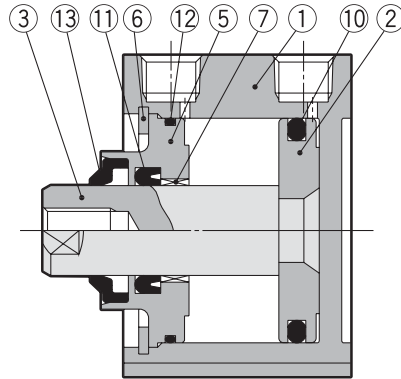

Rod end male thread

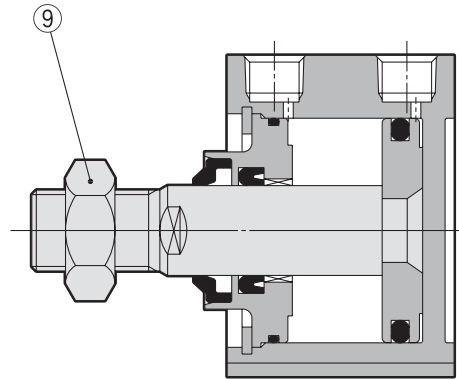

Component Parts

No.	Description	Material	Note
1	Cylinder tube	Aluminum alloy	Hard anodized
2	Piston	Aluminum alloy	Chromated
3	Piston rod	Stainless steel	ø20 to ø25
		Carbon steel	ø32 to ø100, Hard chrome plated
4	Rod cover	Aluminum alloy	ø20 to ø32, Anodized
5	Collar	Aluminum alloy	ø40 to ø100, Anodized
6	Retaining ring	Carbon tool steel	ø40 to ø100, Phosphate coated
7	Bushing	Oil-impregnated sintered alloy	ø20, ø25
		Bearing alloy	ø32 to ø100
8	Hexagon socket head cap screw	Chromium molybdenum steel	ø20 to ø32, Nickel plated
9	Rod end nut	Carbon steel	Nickel plated
10	Piston seal	R: NBR	
		V: FKM	
11	Rod seal	R: NBR	
		V: FKM	
12	Tube gasket	R: NBR	
		V: FKM	
13	Rod scraper	R: NBR	
		V: FKM	

* R: NBR seal (Nitrile rubber) V: FKM seal (Fluororubber)

Replacement Parts/Seal Kit

Bore size (mm)	Kit number		Contents
	R: NBR	V: FKM	
20	CQ2B20R-PS	CQ2B20V-PS	Kits include items ⑩, ⑪, ⑫ from the table.
25	CQ2B25R-PS	CQ2B25V-PS	
32	CQ2B32R-PS	CQ2B32V-PS	
40	CQ2B40R-PS	CQ2B40V-PS	
50	CQ2B50R-PS	CQ2B50V-PS	
63	CQ2B63R-PS	CQ2B63V-PS	
80	CQ2B80R-PS	CQ2B80V-PS	
100	CQ2B100R-PS	CQ2B100V-PS	

* Seal kit includes ⑩, ⑪, ⑫. Order the seal kit based on each bore size.

* A rod scraper cannot be replaced independently. It is press-fitted, so replace it not only with a rod cover and collar, but also with a rod cover assembly and collar assembly. Contact SMC separately to order.

* The seal kit does not include a grease pack, order it separately.

Grease pack part no.: GR-S-010 (10 g)

Construction

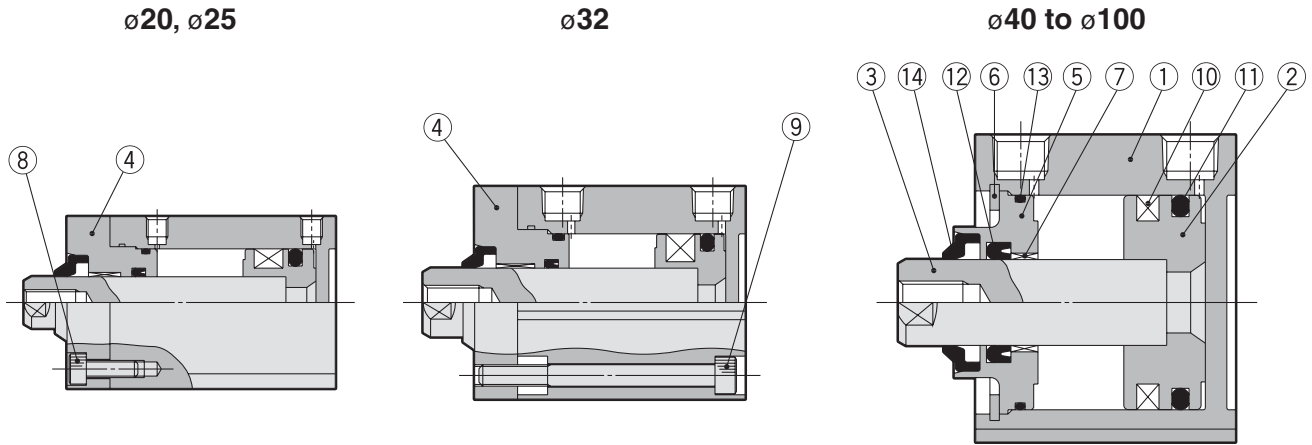

Component Parts

No.	Description	Material	Note
1	Cylinder tube	Aluminum alloy	Hard anodized
2	Piston	Aluminum alloy	Chromated
3	Piston rod	Stainless steel	ø20 to ø25
		Carbon steel	ø32 to ø100, Hard chrome plated
4	Rod cover	Aluminum alloy	ø20 to ø32, anodized
5	Collar	Aluminum alloy	ø40 to ø100, Anodized
6	Retaining ring	Carbon tool steel	Phosphate coated
7	Bushing	Oil-impregnated sintered alloy	ø20, ø25
		Bearing alloy	ø30 to ø100
8	Hexagon socket head cap screw	Chromium molybdenum steel	ø20 ø25, Nickel plated
9	Hexagon socket head cap screw	Chromium molybdenum steel	ø32, Nickel plated
10	Magnet	—	
11	Piston seal	R: NBR	
		V: FKM	
12	Rod seal	R: NBR	
		V: FKM	
13	Tube gasket	R: NBR	
		V: FKM	
14	Rod scraper	R: NBR	
		V: FKM	

* R: NBR seal (Nitrile rubber)
V: FKM seal (Fluororubber)

Replacement Parts/Seal Kit

Bore size (mm)	Kit number		Contents
	R: NBR	V: FKM	
20	CQ2B20R-PS	CQ2B20V-PS	Kits include items ⑪, ⑫, ⑬ from the table.
25	CQ2B25R-PS	CQ2B25V-PS	
32	CQ2B32R-PS	CQ2B32V-PS	
40	CQ2B40R-PS	CQ2B40V-PS	
50	CQ2B50R-PS	CQ2B50V-PS	
63	CQ2B63R-PS	CQ2B63V-PS	
80	CQ2B80R-PS	CQ2B80V-PS	
100	CQ2B100R-PS	CQ2B100V-PS	

* Seal kit includes ⑪, ⑫, ⑬. Order the seal kit based on each bore size.
* A rod scraper cannot be replaced independently. It is press-fitted, so replace it not only with a rod cover and collar, but also with a rod cover assembly and collar assembly. Contact SMC separately to order.
* The seal kit does not include a grease pack, order it separately.
Grease pack part no.: GR-S-010 (10 g)

Standard

Single Acting

Double Rod

Axial Piping

Water Resistant

High Lateral Load

End Lock

Clean Series

Copper/Fluorine free series

Construction and Parts



Warranty and Operating Instructions

Mounting and Auto Switches

Made to Order

Safety Instructions

These safety instructions are intended to prevent hazardous situations and/or equipment damage. These instructions indicate the level of potential hazard with the labels of “**Caution**,” “**Warning**” or “**Danger**.” They are all important notes for safety and must be followed in addition to International Standards (ISO/IEC)*1) and other safety regulations.

-  **Caution:** **Caution** indicates a hazard with a low level of risk which, if not avoided, could result in minor or moderate injury.
-  **Warning:** **Warning** indicates a hazard with a medium level of risk which, if not avoided, could result in death or serious injury.
-  **Danger :** **Danger** indicates a hazard with a high level of risk which, if not avoided, will result in death or serious injury.

*1) ISO 4414: Pneumatic fluid power—General rules relating to systems.
 ISO 4413: Hydraulic fluid power—General rules relating to systems.
 IEC 60204-1: Safety of machinery—Electrical equipment of machines.
 (Part 1: General requirements)
 ISO 10218-1: Manipulating industrial robots - Safety.
 etc.

Warning

- 1. The compatibility of the product is the responsibility of the person who designs the equipment or decides its specifications.**
 Since the product specified here is used under various operating conditions, its compatibility with specific equipment must be decided by the person who designs the equipment or decides its specifications based on necessary analysis and test results. The expected performance and safety assurance of the equipment will be the responsibility of the person who has determined its compatibility with the product. This person should also continuously review all specifications of the product referring to its latest catalog information, with a view to giving due consideration to any possibility of equipment failure when configuring the equipment.
- 2. Only personnel with appropriate training should operate machinery and equipment.**
 The product specified here may become unsafe if handled incorrectly. The assembly, operation and maintenance of machines or equipment including our products must be performed by an operator who is appropriately trained and experienced.
- 3. Do not service or attempt to remove product and machinery/equipment until safety is confirmed.**
 1. The inspection and maintenance of machinery/equipment should only be performed after measures to prevent falling or runaway of the driven objects have been confirmed.
 2. When the product is to be removed, confirm that the safety measures as mentioned above are implemented and the power from any appropriate source is cut, and read and understand the specific product precautions of all relevant products carefully.
 3. Before machinery/equipment is restarted, take measures to prevent unexpected operation and malfunction.
- 4. Contact SMC beforehand and take special consideration of safety measures if the product is to be used in any of the following conditions.**
 1. Conditions and environments outside of the given specifications, or use outdoors or in a place exposed to direct sunlight.
 2. Installation on equipment in conjunction with atomic energy, railways, air navigation, space, shipping, vehicles, military, medical treatment, combustion and recreation, or equipment in contact with food or beverages, emergency stop circuits, clutch and brake circuits in press applications, safety equipment or other applications unsuitable for the standard specifications described in the product catalog.
 3. An application which could have negative effects on people, property, or animals requiring special safety analysis.
 4. Use in an interlock circuit, which requires the provision of double interlock for possible failure by using a mechanical protective function, and periodical checks to confirm proper operation.

Caution

- 1. The product is provided for use in manufacturing industries.**
 The product herein described is basically provided for peaceful use in manufacturing industries.
 If considering using the product in other industries, consult SMC beforehand and exchange specifications or a contract if necessary.
 If anything is unclear, contact your nearest sales branch.

Limited Warranty and Disclaimer/ Compliance Requirements

The product used is subject to the following “Limited Warranty and Disclaimer” and “Compliance Requirements”.
 Read and accept them before using the product.

Limited Warranty and Disclaimer

1. The warranty period of the product is 1 year in service or 1.5 years after the product is delivered.*2)
 Also, the product may have specified durability, running distance or replacement parts. Please consult your nearest sales branch.
2. For any failure or damage reported within the warranty period which is clearly our responsibility, a replacement product or necessary parts will be provided.
 This limited warranty applies only to our product independently, and not to any other damage incurred due to the failure of the product.
3. Prior to using SMC products, please read and understand the warranty terms and disclaimers noted in the specified catalog for the particular products.

***2) Vacuum pads are excluded from this 1 year warranty.**

A vacuum pad is a consumable part, so it is warranted for a year after it is delivered. Also, even within the warranty period, the wear of a product due to the use of the vacuum pad or failure due to the deterioration of rubber material are not covered by the limited warranty.

Compliance Requirements

1. The use of SMC products with production equipment for the manufacture of weapons of mass destruction (WMD) or any other weapon is strictly prohibited.
2. The exports of SMC products or technology from one country to another are governed by the relevant security laws and regulations of the countries involved in the transaction. Prior to the shipment of an SMC product to another country, assure that all local rules governing that export are known and followed.

Standard, Single Rod

Retaining Ring Installation/Removal

⚠ Caution

1. For installation and removal, use an appropriate pair of pliers (tool for installing a type C retaining ring).
2. Even if a proper plier (tool for installing a type C retaining ring) is used, it is likely to inflict damage to a human body or peripheral equipment, as a retaining ring may be flown out of the tip of a plier (tool for installing a type C retaining ring). Be cautious with the popping of a retaining ring. Also be certain that a retaining ring is placed firmly into the groove of rod cover before supplying air at the time of installment.

Mounting

⚠ Caution

The CQ2 series compact cylinders are designed to create compact mechanical equipment and promote space saving. Thus, if it is used in the same manner as conventional cylinders such as tie-rod cylinders, it may degrade the performance. Pay sufficient attention to the operating conditions when using.

1. Allowable lateral load

Lateral load that can apply to the piston rod end is limited. If a cylinder is used with a lateral load over the limit, it may cause air leakage due to abnormal friction of seals, galling of cylinder tubes and pistons, or abnormal friction of the bearing part. The lateral load applied to the piston rod must be within the allowable range

Mounting

indicated in this catalog. When the load exceeds the limit, use a double rod cylinder, install a guide, or change the bore size to suit the load in order to make the load within the allowable range. As a standard product, an high lateral load type cylinder that is resistant to approx. 2 times more than the conventional compact CQ2 series is also available (page 103).

2. Connection with a work piece

When a work piece is mounted on the piston rod end, connect them aligning the center of piston rod and a work piece. If they are off-center, lateral load is generated and phenomena mentioned in (1) may occur. In order not to apply the off-center load, use of a floating joint or simple joint is recommended.

3. Simultaneous use of multiple cylinders

It is difficult to control the speed of pneumatic cylinders. The following conditions cause speed change: change in supply pressure, load, temperature and lubrication, performance difference of each cylinder, deterioration of each part over time, etc. A speed controller can be used to control the speed of multiple cylinders simultaneously for a short period of time, but depending on conditions, it may not work as desired. If multiple cylinders cannot operate simultaneously, unreasonable force is applied to the piston rod because cylinder positions may not be the same. This may cause abnormal friction of seals and bearings, and galling of cylinder tubes and pistons. Do not use an application to operate several cylinders simultaneously by adjusting cylinder speed. If this is inevitable, use a high rigid guide against load, so that the cylinder is not damaged even when each cylinder output is slightly different.

Standard, Double Rod

Retaining Ring Installation/Removal

⚠ Caution

1. For installation and removal, use an appropriate pair of pliers (tool for installing a type C retaining ring).
2. Even if a proper plier (tool for installing a type C retaining ring) is used, it is likely to inflict damage to a human body or peripheral equipment, as a retaining ring may be flown out of the tip of a plier (tool for installing a type C retaining ring). Be cautious with the popping of a retaining ring. Also be certain that a retaining ring is placed firmly into the groove of rod cover before supplying air at the time of installment.

Mounting

⚠ Warning

Do not apply reverse torque to the piston rods sticking out from both sides of this cylinder at the same time. The torque makes connection threads inside loosen, which may cause an accident or malfunction.

Install or remove loads while the piston rod width across flat is secured. Do not fix the other side of the piston rod width across flat and apply reverse torque.

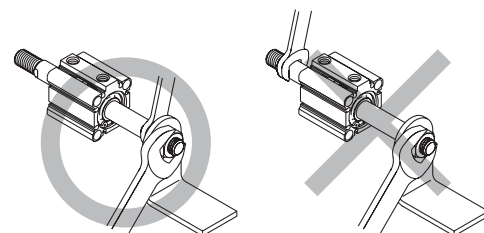

Standard

Single Acting

Double Rod

Axial Piping

Water Resistant

High Lateral Load

End Lock

Clean Series

Copper/Fluorine free series

Construction and Parts

Warranty and Operating Instructions

Mounting and Auto Switches

Made to Order

Single Rod, Non-Rotating Rod

Retaining Ring Installation/Removal

⚠ Caution

1. For installation and removal, use an appropriate pair of pliers (tool for installing a type C retaining ring).
2. Even if a proper plier (tool for installing a type C retaining ring) is used, it is likely to inflict damage to a human body or peripheral equipment, as a retaining ring may be flown out of the tip of a plier (tool for installing a type C retaining ring). Be cautious with the popping of a retaining ring. Also be certain that a retaining ring is placed firmly into the groove of rod cover before supplying air at the time of installment.

Mounting

1. Install or remove loads while the piston rod width across flat is secured.

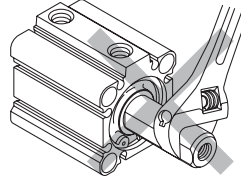

2. Using a non-rotating rod cylinder
Avoid using the air cylinder in such a way that rotational torque would be applied to the piston rod. If rotational torque is applied, the non-rotating guide will deform, causing a loss of non-rotating accuracy.
Use the below table as a guide for the allowable rotational torque ranges.

Allowable rotational torque	ø12	ø16	ø20	ø25	ø32	ø40	ø50	ø63
N-m or less	0.04	0.15	0.20	0.25	0.44	0.44	0.44	0.44

Operate the cylinder in such a way that the load to the piston rod is always applied in the axial direction.

3. When a work piece is secured to the end of the piston rod, ensure that the piston rod is retracted entirely, and place a wrench on the portion of the rod that protrudes beyond the section. Also, tighten in a way that prevents the tightening torque from being applied to the non-rotating guide.

Double Rod, Non-Rotating Rod

Retaining Ring Installation/Removal

⚠ Caution

1. For installation and removal, use an appropriate pair of pliers (tool for installing a type C retaining ring).
2. Even if a proper plier (tool for installing a type C retaining ring) is used, it is likely to inflict damage to a human body or peripheral equipment, as a retaining ring may be flown out of the tip of a plier (tool for installing a type C retaining ring). Be cautious with the popping of a retaining ring. Also be certain that a retaining ring is placed firmly into the groove of rod cover before supplying air at the time of installment.

Mounting

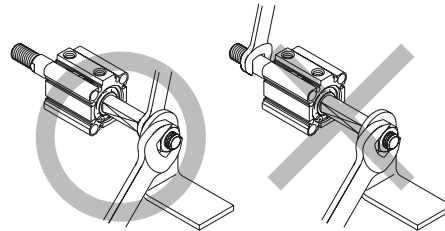

2. Using a non-rotating rod cylinder
Avoid using the air cylinder in such a way that rotational torque would be applied to the piston rod. If rotational torque is applied, the non-rotating guide will deform, causing a loss of non-rotating accuracy.
Use the below table as a guide for the allowable rotational torque ranges.

Allowable rotational torque	ø12	ø16	ø20	ø25	ø32	ø40	ø50	ø63
N-m or less	0.04	0.15	0.20	0.25	0.44	0.44	0.44	0.44

Mounting

⚠ Warning

1. Do not apply reverse torque to the piston rods sticking out from both sides of this cylinder at the same time. The torque makes connection threads inside loosen, which may cause an accident or malfunction. Install or remove loads while the piston rod width across flat is secured. Also, tighten by giving consideration to prevent the tightening torque from being applied to the non-rotating guide. Do not fix the other side of the piston rod width across flat and apply reverse torque.

Axial Piping

Retaining Ring Installation/Removal

⚠ Caution

1. For installation and removal, use an appropriate pair of pliers (tool for installing a type C retaining ring).
2. Even if a proper plier (tool for installing a type C retaining ring) is used, it is likely to inflict damage to a human body or peripheral equipment, as a retaining ring may be flown out of the tip of a plier (tool for installing a type C retaining ring). Be cautious with the popping of a retaining ring. Also be certain that a retaining ring is placed firmly into the groove of rod cover before supplying air at the time of installment.

Mounting/Removal

1. Do not remove the hexagon socket set screw on the side of the rod.
 - Be aware that if the hexagon socket set screw is removed with compressed air supplied to the cylinder, an internal steel ball could fly out or the compressed air could be discharged, leading to injury to humans or damage to peripheral equipment.

Water Resistant

Retaining Ring Installation/Removal

⚠ Caution

1. For installation and removal, use an appropriate pair of pliers (tool for installing a type C retaining ring).
2. Even if a proper plier (tool for installing a type C retaining ring) is used, it is likely to inflict damage to a human body or peripheral equipment, as a retaining ring may be flown out of the tip of a plier (tool for installing a type C retaining ring). Be cautious with the popping of a retaining ring. Also be certain that a retaining ring is placed firmly into the groove of rod cover before supplying air at the time of installment.

Handling Precautions

⚠ Caution

4. When the cylinder is exposed to dust or sand, or is used in a place where liquid from the piston rod splashes, use the heavy-duty scraper (-XC4) type.
5. If there is a possibility of liquid splashing on cylinder fittings when using an air cylinder, use insert fittings, self-align fittings, steel piping, etc. Consider the compatibility of liquid components and piping materials before using.
6. When selecting seals, generally use NBR (nitrile rubber) seals with liquids that do not contain chlorine and sulfur, and use FKM (fluoro rubber) seals with liquids that contain chlorine and sulfur. However, depending on the type and the brand of liquid (such as coolant liquid) that splashes on the cylinder, the operating life of seals may be reduced dramatically.

Handling Precautions

⚠ Caution

1. Before installing a cylinder, thoroughly flush out the piping to prevent dust or cutting chips from entering the cylinder. For hydraulic cylinders, use the air bleed valve to release the air inside the cylinder.
2. Eccentric loads applied to the piston rod dramatically shorten the service life. Use the piston rod by always applying a load in an axial direction.
3. Make sure not to scratch or gouge the sliding portion of the piston rod, as this could damage the seals and lead to leakage.

Examples of coolant liquid

Shimiron, PA-O-5 (Daido Chemical Industry Co.,Ltd.) (NBR seals)
 Noritake Cool, AFG-S (Noritake Co.,Ltd.) (NBR seals)
 Yushiroken, S-46S (Yushiro Chemical Industry Co.,Ltd.) (NBR seals)
 Yushiroken, EC-50-T3 (Yushiro Chemical Industry Co.,Ltd.) (NBR seals)
 Yushiron Oil, No. 23 (Yushiro Chemical Industry Co.,Ltd.) (FKM seals)
 Daphne Cut, Hs-1 (Idemitsu Kosan Co., Ltd.) (FKM seals)

Standard

Single Acting

Double Rod

Axial Piping

Water Resistant

High Lateral Load

End Lock

Clean Series

Copper/Fluorine free series

Construction and Parts

Warranty and Operating Instructions

Mounting and Auto Switches

Made to Order

End Lock

Use the Recommended Pneumatic Circuit

⚠ Caution

- This is necessary for the correct locking and unlocking actions.

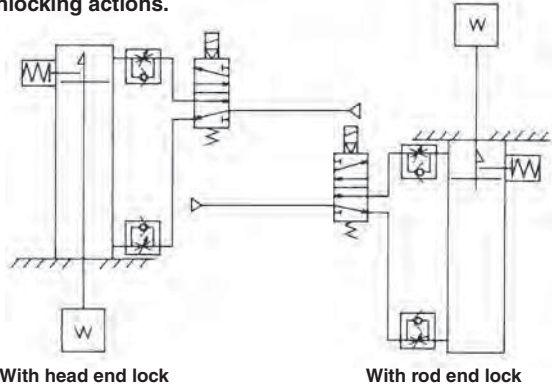

Operating Precautions

⚠ Caution

- Do not use 3-position solenoid valves.**
Avoid use in combination with 3-position solenoid valves (especially closed center metal seal types). If pressure is trapped in the port on the lock mechanism side, the cylinder cannot be locked. Furthermore, even after being locked, the lock may be released after some time, due to air leaking from the solenoid valve and entering the cylinder.
- Back pressure is required for releasing the lock.**
Before starting operation, be sure to control the system so that air is supplied to the side without the lock mechanism as shown in the above figure. There is a possibility that the lock may not be released. (Refer to section on releasing the lock.)
- Release the lock for mounting or adjusting the cylinder.**
If mounting or other work is performed when the cylinder is locked, the lock unit may be damaged.
- Operate with a load ratio of 50% or less.**
If the load ratio exceeds 50%, this may cause problems such as failure of the lock to release, or damage to the lock unit.
- Do not operate multiple cylinders in synchronization.**
Avoid applications in which two or more end lock cylinders are synchronized to move one work piece, as one of the cylinder locks may not be able to release when required.
- Use a speed controller with meter-out control.**
Lock cannot be released occasionally by meter-in control.
- Be sure to operate completely to the cylinder stroke end on the side with the lock.**
If the cylinder piston does not reach the end of stroke, locking and unlocking may not be possible.
- Adjust the position of an auto switch, so that it could work at both positions where it is distanced from the stroke and a backlash (2 mm).**
When a 2-color indication switch is adjusted for green indication at the stroke end, it may change to red for the backlash return, but this is not abnormal.

Operating Pressure

⚠ Caution

1. Supply air pressure of 0.15 MPa or higher to the port on the side that has the lock mechanism, as it is necessary for releasing the lock.

Exhaust Speed

⚠ Caution

1. When the pressure on the side with the lock mechanism drops to 0.05 MPa or below, the lock engages automatically. If the piping on the side with the lock mechanism is thin and long, or if the speed controller is away from the cylinder port, the lock engagement may take some time due to decline of the exhaust speed. The same result will be caused by clogging of the silencer installed at the EXH port of the solenoid valve.

Releasing the Lock

⚠ Warning

1. Before releasing the lock, be sure to supply air to the side without the lock mechanism, so that there is no load applied to the lock mechanism when it is released. (Refer to the recommended pneumatic circuits.) If the lock is released when the port on the other side is in an exhaust state, and with a load applied to the lock unit, the lock unit may be subjected to an excessive force and be damaged. Also, it is very dangerous because the piston rod will be rushed to move.

Manual Release

⚠ Caution

1. Manual release (Non-lock type)

Insert the accessory bolt from the top of the rubber cap (it is not necessary to remove the rubber cap), and after screwing it into the lock piston, pull it to release the lock. If you stop pulling the bolt, the lock will return to an operational state.

Thread sizes, pulling forces and strokes are as shown below.

Bore size (mm)	Thread size	Pulling force (N)	Stroke (mm)
20, 25, 32	M2.5 x 0.45 x 25 ℓ or more	4.9	2
40, 50, 63	M3 x 0.5 x 30 ℓ or more	10	3
80, 100	M5 x 0.8 x 40 ℓ or more	24.5	3

Remove the bolt for normal operation. It can cause lock malfunction or faulty release.

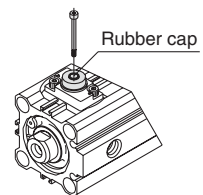

2. Manual release (Lock type)

While pushing the M/O knob, turn it 90° counterclockwise. The lock is released (and remains in a released state) by aligning the ▲ mark on the cap with the ▼ OFF mark on the M/O knob. When locking is desired, turn the M/O knob clockwise 90° while pushing fully, correspond ▲ on cap and ▼ ON mark on the M/O knob. The correct position is confirmed by a click sound "click". If not confirmed, locking is not done.

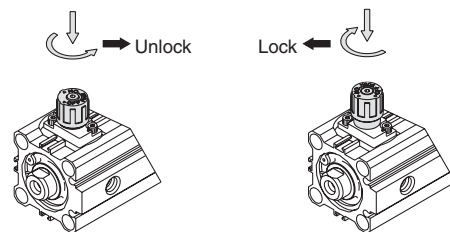

Manually locked state

Manually unlocked state

Mounting Bolts

Standard	156
Large Bore	158
Non-Rotating Rod	159
Single Acting	161
Double Rod	163
Double Rod, Large Bore	165
Double Rod, Non-Rotating Rod	166
Axial Piping	168
Axial Piping, Single Acting	170
High Lateral Load	172
End Lock	174
Water Resistant	175

Standard

Single Acting

Double Rod

Axial Piping

Water Resistant

High Lateral Load

End Lock

Clean Series

Copper/Fluorine free series

Construction and Parts

Warranty and Operating Instructions

Mounting and Auto Switches

Made to Order

Series (N)CQ2 Standard

Mounting Bolt

Mounting Bolt for (N)CQ2B/Without Auto Switch

Mounting method: Mounting bolt for through-hole mounting of the CQ2B is available as an option. Refer to the following for ordering procedures. Order the actual number of bolts that will be used.

Example) CQ-M3x25L 4 pcs.

Material: Chromium molybdenum steel
Surface treatment: Nickel plated

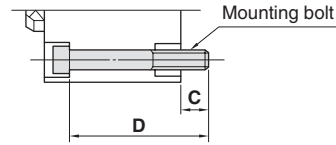

Cylinder model	C	D	Bolt part no.
(N)CQ2B12-5D	6.5	25	CQ-M3 x 25L
-10D		30	x 30L
-15D		35	x 35L
-20D		40	x 40L
-25D		45	x 45L
-30D	50	x 50L	
(N)CQ2B16-5D	5	25	CQ-M3 x 25L
-10D		30	x 30L
-15D		35	x 35L
-20D		40	x 40L
-25D		45	x 45L
-30D	50	x 50L	
(N)CQ2B20-5D	7.5	25	CQ-M5 x 25L
-10D		30	x 30L
-15D		35	x 35L
-20D		40	x 40L
-25D		45	x 45L
-30D		50	x 50L
-35D		55	x 55L
-40D		60	x 60L
-45D		65	x 65L
-50D		70	x 70L
(N)CQ2B25-5D	9.5	30	CQ-M5 x 30L
-10D		35	x 35L
-15D		40	x 40L
-20D		45	x 45L
-25D		50	x 50L
-30D		55	x 55L
-35D		60	x 60L
-40D		65	x 65L
-45D		70	x 70L
-50D		75	x 75L
(N)CQ2B32-5DZ	9	30	CQ-M5 x 30L
-10DZ		35	x 35L
-15DZ		40	x 40L
-20DZ		45	x 45L
-25DZ		50	x 50L
-30DZ		55	x 55L
-35DZ		60	x 60L
-40DZ		65	x 65L
-45DZ		70	x 70L
-50DZ		75	x 75L
-55DZ-XB10		90	x 90L
-60DZ-XB10		95	x 95L
-65DZ-XB10		100	x 100L
-70DZ-XB10		105	x 105L
-75DZ		110	x 110L
-80DZ-XB10	115	x 115L	
-85DZ-XB10	120	x 120L	
-90DZ-XB10	125	x 125L	
-95DZ-XB10	130	x 130L	
-100DZ	135	x 135L	

Cylinder model	C	D	Bolt part no.
(N)CQ2B40-5DZ	7.5	35	CQ-M5 x 35L
-10DZ		40	x 40L
-15DZ		45	x 45L
-20DZ		50	x 50L
-25DZ		55	x 55L
-30DZ		60	x 60L
-35DZ		65	x 65L
-40DZ		70	x 70L
-45DZ		75	x 75L
-50DZ		80	x 80L
-55DZ-XB10	95	x 95L	
-60DZ-XB10	100	x 100L	
-65DZ-XB10	105	x 105L	
-70DZ-XB10	110	x 110L	
-75DZ	115	x 115L	
-80DZ-XB10	120	x 120L	
-85DZ-XB10	125	x 125L	
-90DZ-XB10	130	x 130L	
-95DZ-XB10	135	x 135L	
-100DZ	140	x 140L	
(N)CQ2B50-10DZ	12.5	45	CQ-M6 x 45L
-15DZ		50	x 50L
-20DZ		55	x 55L
-25DZ		60	x 60L
-30DZ		65	x 65L
-35DZ		70	x 70L
-40DZ		75	x 75L
-45DZ		80	x 80L
-50DZ		85	x 85L
-55DZ-XB10		100	x 100L
-60DZ-XB10		105	x 105L
-65DZ-XB10		110	x 110L
-70DZ-XB10		115	x 115L
-75DZ		120	x 120L
-80DZ-XB10		125	x 125L
-85DZ-XB10	130	x 130L	
-90DZ-XB10	135	x 135L	
-95DZ-XB10	140	x 140L	
-100DZ	145	x 145L	
(N)CQ2B63-10DZ	14.5	50	CQ-M8 x 50L
-15DZ		55	x 55L
-20DZ		60	x 60L
-25DZ		65	x 65L
-30DZ		70	x 70L
-35DZ		75	x 75L
-40DZ		80	x 80L
-45DZ		85	x 85L
-50DZ		90	x 90L
-55DZ-XB10		105	x 105L
-60DZ-XB10		110	x 110L
-65DZ-XB10		115	x 115L
-70DZ-XB10		120	x 120L
-75DZ		125	x 125L
-80DZ-XB10		130	x 130L
-85DZ-XB10	135	x 135L	
-90DZ-XB10	140	x 140L	
-95DZ-XB10	145	x 145L	
-100DZ	150	x 150L	

Cylinder model	C	D	Bolt part no.
(N)CQ2B80-10DZ	15	55	CQ-M10 x 55L
-15DZ		60	x 60L
-20DZ		65	x 65L
-25DZ		70	x 70L
-30DZ		75	x 75L
-35DZ		80	x 80L
-40DZ		85	x 85L
-45DZ		90	x 90L
-50DZ		95	x 95L
-55DZ-XB10		110	x 110L
-60DZ-XB10		115	x 115L
-65DZ-XB10		120	x 120L
-70DZ-XB10		125	x 125L
-75DZ		130	x 130L
-80DZ-XB10		135	x 135L
-85DZ-XB10	140	x 140L	
-90DZ-XB10	145	x 145L	
-95DZ-XB10	150	x 150L	
-100DZ	155	x 155L	
(N)CQ2B100-10DZ	15.5	65	CQ-M10 x 65L
-15DZ		70	x 70L
-20DZ		75	x 75L
-25DZ		80	x 80L
-30DZ		85	x 85L
-35DZ		90	x 90L
-40DZ		95	x 95L
-45DZ		100	x 100L
-50DZ		105	x 105L
-55DZ-XB10		120	x 120L
-60DZ-XB10		125	x 125L
-65DZ-XB10		130	x 130L
-70DZ-XB10		135	x 135L
-75DZ		140	x 140L
-80DZ-XB10		145	x 145L
-85DZ-XB10	150	x 150L	
-90DZ-XB10	155	x 155L	
-95DZ-XB10	160	x 160L	
-100DZ	165	x 165L	

Mounting Bolt for (N)CDQ2B/With Auto Switch

Mounting method: Mounting bolt for through-hole mounting of the CDQ2B is available as an option. Refer to the following for ordering procedures. Order the actual number of bolts that will be used.

Example) CQ-M3x35L 2 pcs.

Material: Chromium molybdenum steel
Surface treatment: Nickel plated

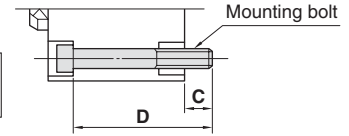

Cylinder model	C	D	Bolt part no.	Cylinder model	C	D	Bolt part no.	Cylinder model	C	D	Bolt part no.
(N)CDQ2B12-5DZ	5.5	35	CQ-M3 x 35L	(N)CDQ2B40-5DZ	7.5	45	CQ-M5 x 45L	(N)CDQ2B80-10DZ	15	65	CQ-M10 x 65L
-10DZ		40	x 40L	-10DZ		50	x 50L	-15DZ		70	x 70L
-15DZ		45	x 45L	-15DZ		55	x 55L	-20DZ		75	x 75L
-20DZ		50	x 50L	-20DZ		60	x 60L	-25DZ		80	x 80L
-25DZ		55	x 55L	-25DZ		65	x 65L	-30DZ		85	x 85L
-30DZ	65	x 60L	-30DZ	70	x 70L	-35DZ	90	x 90L			
(N)CDQ2B16-5DZ	8	40	CQ-M3 x 40L	-35DZ	75	x 75L	-40DZ	95		x 95L	
-10DZ		45	x 45L	-40DZ	80	x 80L	-45DZ	100		x 100L	
-15DZ		50	x 50L	-45DZ	85	x 85L	-50DZ	105		x 105L	
-20DZ		55	x 55L	-50DZ	90	x 90L	-55DZ-XB10	110		x 110L	
-25DZ		60	x 60L	-55DZ-XB10	95	x 95L	-60DZ-XB10	115		x 115L	
-30DZ	65	x 65L	-60DZ-XB10	100	x 100L	-65DZ-XB10	120	x 120L			
(N)CDQ2B20-5DZ	10.5	40	CQ-M5 x 40L	-65DZ-XB10	105	x 105L	-70DZ-XB10	125		x 125L	
-10DZ		45	x 45L	-70DZ-XB10	110	x 110L	-75DZ	130		x 130L	
-15DZ		50	x 50L	-75DZ	115	x 115L	-80DZ-XB10	135		x 135L	
-20DZ		55	x 55L	-80DZ-XB10	120	x 120L	-85DZ-XB10	140	x 140L		
-25DZ		60	x 60L	-85DZ-XB10	125	x 125L	-90DZ-XB10	145	x 145L		
-30DZ		65	x 65L	-90DZ-XB10	130	x 130L	-95DZ-XB10	150	x 150L		
-35DZ		70	x 70L	-95DZ-XB10	135	x 135L	-100DZ	155	x 155L		
-40DZ		75	x 75L	-100DZ	140	x 140L	(N)CDQ2B100-10DZ	75	CQ-M10 x 75L		
-45DZ		80	x 80L	(N)CDQ2B50-10DZ	55	CQ-M6 x 55L	-15DZ	80	x 80L		
-50DZ		85	x 85L	-15DZ	60	x 60L	-20DZ	85	x 85L		
(N)CDQ2B25-5DZ	9.5	40	CQ-M5 x 40L	-20DZ	65	x 65L	-25DZ	90	x 90L		
-10DZ		45	x 45L	-25DZ	70	x 70L	-30DZ	95	x 95L		
-15DZ		50	x 50L	-30DZ	75	x 75L	-35DZ	100	x 100L		
-20DZ		55	x 55L	-35DZ	80	x 80L	-40DZ	105	x 105L		
-25DZ		60	x 60L	-40DZ	85	x 85L	-45DZ	110	x 110L		
-30DZ		65	x 65L	-45DZ	90	x 90L	-50DZ	115	x 115L		
-35DZ		70	x 70L	-50DZ	95	x 95L	-55DZ-XB10	120	x 120L		
-40DZ		75	x 75L	-55DZ-XB10	100	x 100L	-60DZ-XB10	125	x 125L		
-45DZ		80	x 80L	-60DZ-XB10	105	x 105L	-65DZ-XB10	130	x 130L		
-50DZ		85	x 85L	-65DZ-XB10	110	x 110L	-70DZ-XB10	135	x 135L		
(N)CDQ2B32-5DZ	9	40	CQ-M5 x 40L	-70DZ-XB10	115	x 115L	-75DZ	140	x 140L		
-10DZ		45	x 45L	-75DZ	120	x 120L	-80DZ-XB10	145	x 145L		
-15DZ		50	x 50L	-80DZ-XB10	125	x 125L	-85DZ-XB10	150	x 150L		
-20DZ		55	x 55L	-85DZ-XB10	130	x 130L	-90DZ-XB10	155	x 155L		
-25DZ		60	x 60L	-90DZ-XB10	135	x 135L	-95DZ-XB10	160	x 160L		
-30DZ		65	x 65L	-95DZ-XB10	140	x 140L	-100DZ	165	x 165L		
-35DZ		70	x 70L	-100DZ	145	x 145L	(N)CDQ2B63-10DZ	60	CQ-M8 x 60L		
-40DZ		75	x 75L	(N)CDQ2B63-10DZ	60	CQ-M8 x 60L	-15DZ	65	x 65L		
-45DZ		80	x 80L	-15DZ	65	x 65L	-20DZ	70	x 70L		
-50DZ		85	x 85L	-20DZ	70	x 70L	-25DZ	75	x 75L		
-55DZ-XB10		90	x 90L	-25DZ	75	x 75L	-30DZ	80	x 80L		
-60DZ-XB10		95	x 95L	-30DZ	80	x 80L	-35DZ	85	x 85L		
-65DZ-XB10		100	x 100L	-35DZ	85	x 85L	-40DZ	90	x 90L		
-70DZ-XB10		105	x 105L	-40DZ	90	x 90L	-45DZ	95	x 95L		
-75DZ		110	x 110L	-45DZ	95	x 95L	-50DZ	100	x 100L		
-80DZ-XB10	115	x 115L	-50DZ	100	x 100L	-55DZ-XB10	105	x 105L			
-85DZ-XB10	120	x 120L	-55DZ-XB10	105	x 105L	-60DZ-XB10	110	x 110L			
-90DZ-XB10	125	x 125L	-60DZ-XB10	110	x 110L	-65DZ-XB10	115	x 115L			
-95DZ-XB10	130	x 130L	-65DZ-XB10	115	x 115L	-70DZ-XB10	120	x 120L			
-100DZ	135	x 135L	-70DZ-XB10	120	x 120L	-75DZ	125	x 125L			
			-75DZ	125	x 125L	-80DZ-XB10	130	x 130L			
			-80DZ-XB10	130	x 130L	-85DZ-XB10	135	x 135L			
			-85DZ-XB10	135	x 135L	-90DZ-XB10	140	x 140L			
			-90DZ-XB10	140	x 140L	-95DZ-XB10	145	x 145L			
			-95DZ-XB10	145	x 145L	-100DZ	150	x 150L			
			-100DZ	150	x 150L						

- Standard
- Single Acting
- Double Rod
- Axial Piping
- Water Resistant
- High Lateral Load
- End Lock
- Clean Series
- Copper/Fluorine free series
- Construction and Parts
- Warranty and Operating Instructions
- Mounting and Auto Switches
- Made to Order

Mounting Bolt for (N)CQ2B

Mounting method: Mounting bolt for through-hole mounting of the CQ2B is available as an option. Refer to the following for ordering procedures. Order the actual number of bolts that will be used.

Example) CQ-M12x100L 4 pcs.

Note 1) To install a through-hole type mounting bolt, make sure to use the flat washer that is provided.

Note 2) For mounting bolts for the stroke length exceeding 100 mm, use the OA screw provided on the cylinder tube to secure the cylinder.

Material: Chromium molybdenum steel
Surface treatment: Nickel plated

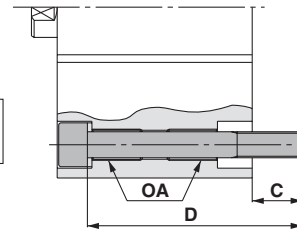

Cylinder model	C	D	Mounting bolt part no.
(N)C□Q2B125/140-10DCZ	22.9	100	CQ-M12 x 100L
-20DCZ		110	x 110L
-30DCZ		120	x 120L
-40DCZ		130	x 130L
-50DCZ		140	x 140L
-75DCZ		165	x 165L
-100DCZ		190	x 190L
(N)C□Q2B160-10DCZ	27.7	110	CQ-M14 x 110L
-20DCZ		120	x 120L
-30DCZ		130	x 130L
-40DCZ		140	x 140L
-50DCZ		150	x 150L
-75DCZ		175	x 175L
-100DCZ		200	x 200L

Cylinder model	C	D	Mounting bolt part no.
C□Q2B180-10DCZ	36	125	CQ-M18 x 125L
-20DCZ		135	x 135L
-30DCZ		145	x 145L
-40DCZ		155	x 155L
-50DCZ		165	x 165L
-75DCZ		190	x 190L
-100DCZ		215	x 215L
C□Q2B200-10DCZ	39	135	CQ-M18 x 135L
-20DCZ		145	x 145L
-30DCZ		155	x 155L
-40DCZ		165	x 165L
-50DCZ		175	x 175L
-75DCZ		200	x 200L
-100DCZ		225	x 225L

Mounting Bolt for (N)CQ2KB/Without Auto Switch

Mounting method: Mounting bolt for through-hole mounting of the CQ2KB is available as an option. Refer to the following for ordering procedures. Order the actual number of bolts that will be used.

Example) CQ-M3x30L 2 pcs.

Material: Chromium molybdenum steel
Surface treatment: Nickel plated

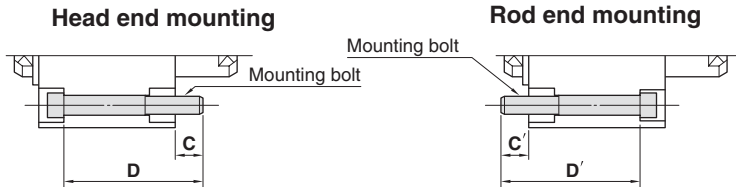

Cylinder model	C	D	Bolt part no.	C'	D'	Bolt part no.
(N)CQ2KB12-5D	6.5	30	CQ-M3 x 30L	6.5	30	CQ-M3 x 30L
-10D		35	x 35L		35	x 35L
-15D		40	x 40L		40	x 40L
-20D		45	x 45L		45	x 45L
-25D		50	x 50L		50	x 50L
-30D		55	x 55L		55	x 55L
(N)CQ2KB16-5D	5	30	CQ-M3 x 30L	5	30	CQ-M3 x 30L
-10D		35	x 35L		35	x 35L
-15D		40	x 40L		40	x 40L
-20D		45	x 45L		45	x 45L
-25D		50	x 50L		50	x 50L
-30D		55	x 55L		55	x 55L
(N)CQ2KB20-5D	8	35	CQ-M5 x 35L	9.5	35	CQ-M5 x 35L
-10D		40	x 40L		40	x 40L
-15D		45	x 45L		45	x 45L
-20D		50	x 50L		50	x 50L
-25D		55	x 55L		55	x 55L
-30D		60	x 60L		60	x 60L
-35D		65	x 65L		65	x 65L
-40D		70	x 70L		70	x 70L
-45D		75	x 75L		75	x 75L
-50D		80	x 80L		80	x 80L
(N)CQ2KB25-5D		10	40		CQ-M5 x 40L	6.5
-10D	45		x 45L	40	x 40L	
-15D	50		x 50L	45	x 45L	
-20D	55		x 55L	50	x 50L	
-25D	60		x 60L	55	x 55L	
-30D	65		x 65L	60	x 60L	
-35D	70		x 70L	65	x 65L	
-40D	75		x 75L	70	x 70L	
-45D	80		x 80L	75	x 75L	
-50D	85		x 85L	80	x 80L	
(N)CQ2KB32-5DZ	8.5	40	CQ-M5 x 40L	10	40	CQ-M5 x 40L
-10DZ		45	x 45L		45	x 45L
-15DZ		50	x 50L		50	x 50L
-20DZ		55	x 55L		55	x 55L
-25DZ		60	x 60L		60	x 60L
-30DZ		65	x 65L		65	x 65L
-35DZ		70	x 70L		70	x 70L
-40DZ		75	x 75L		75	x 75L
-45DZ		80	x 80L		80	x 80L
-50DZ		85	x 85L		85	x 85L
-75DZ		120	x 120L		120	x 120L
-100DZ		145	x 145L		145	x 145L

Cylinder model	C	D	Bolt part no.	C'	D'	Bolt part no.
(N)CQ2KB40-5DZ	7.5	35	CQ-M5 x 35L	7.5	35	CQ-M5 x 35L
-10DZ		40	x 40L		40	x 40L
-15DZ		45	x 45L		45	x 45L
-20DZ		50	x 50L		50	x 50L
-25DZ		55	x 55L		55	x 55L
-30DZ		60	x 60L		60	x 60L
-35DZ		65	x 65L		65	x 65L
-40DZ		70	x 70L		70	x 70L
-45DZ		75	x 75L		75	x 75L
-50DZ		80	x 80L		80	x 80L
-75DZ		115	x 115L		115	x 115L
-100DZ	140	x 140L	140	x 140L		
(N)CQ2KB50-10DZ	12.5	45	CQ-M6 x 45L	12.5	45	CQ-M6 x 45L
-15DZ		50	x 50L		50	x 50L
-20DZ		55	x 55L		55	x 55L
-25DZ		60	x 60L		60	x 60L
-30DZ		65	x 65L		65	x 65L
-35DZ		70	x 70L		70	x 70L
-40DZ		75	x 75L		75	x 75L
-45DZ		80	x 80L		80	x 80L
-50DZ		85	x 85L		85	x 85L
-75DZ		120	x 120L		120	x 120L
-100DZ		145	x 145L		145	x 145L
(N)CQ2KB63-10DZ	14.5	50	CQ-M8 x 50L	14.5	50	CQ-M8 x 50L
-15DZ		55	x 55L		55	x 55L
-20DZ		60	x 60L		60	x 60L
-25DZ		65	x 65L		65	x 65L
-30DZ		70	x 70L		70	x 70L
-35DZ		75	x 75L		75	x 75L
-40DZ		80	x 80L		80	x 80L
-45DZ		85	x 85L		85	x 85L
-50DZ		90	x 90L		90	x 90L
-75DZ		125	x 125L		125	x 125L
-100DZ		150	x 150L		150	x 150L

- Standard
- Single Acting
- Double Rod
- Axial Piping
- Water Resistant
- High Lateral Load
- End Lock
- Clean Series
- Copper/Fluorine free series
- Construction and Parts
- Warranty and Operating Instructions
- Mounting and Auto Switches
- Made to Order

Mounting Bolt for (N)CDQ2KB/With Auto Switch

Mounting method: Mounting bolt for through-hole mounting of the CDQ2KB is available as an option. Refer to the following for ordering procedures. Order the actual number of bolts that will be used.

Example) CQ-M3x35L 2 pcs.

Material: Chromium molybdenum steel
Surface treatment: Nickel plated

Head end mounting

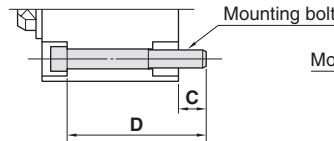

Rod end mounting

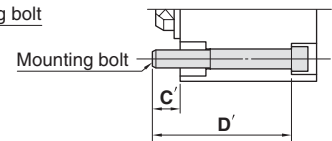

Cylinder model	C	D	Bolt part no.	C'	D'	Bolt part no.
(N)CDQ2KB12-5DCZ	5.5	35	CQ-M3 x 35L	5.5	40	CQ-M3 x 40L
-10DCZ		40	x 40L		45	x 45L
-15DCZ		45	x 45L		50	x 50L
-20DCZ		50	x 50L		55	x 55L
-25DCZ		55	x 55L		60	x 60L
-30DCZ		60	x 60L		65	x 65L
(N)CDQ2KB16-5DZ	8	40	CQ-M3 x 40L	8	45	CQ-M3 x 45L
-10DZ		45	x 45L		50	x 50L
-15DZ		50	x 50L		55	x 55L
-20DZ		55	x 55L		60	x 60L
-25DZ		60	x 60L		65	x 65L
-30DZ		65	x 65L		70	x 70L
(N)CDQ2KB20-5DZ	10.5	40	CQ-M5 x 40L	7.5	45	CQ-M5 x 45L
-10DZ		45	x 45L		50	x 50L
-15DZ		50	x 50L		55	x 55L
-20DZ		55	x 55L		60	x 60L
-25DZ		60	x 60L		65	x 65L
-30DZ		65	x 65L		70	x 70L
-35DZ		70	x 70L		75	x 75L
-40DZ		75	x 75L		80	x 80L
-45DZ		80	x 80L		85	x 85L
-50DZ		85	x 85L		90	x 90L
(N)CDQ2KB25-5DZ	9.5	40	CQ-M5 x 40L	6.5	45	CQ-M5 x 45L
-10DZ		45	x 45L		50	x 50L
-15DZ		50	x 50L		55	x 55L
-20DZ		55	x 55L		60	x 60L
-25DZ		60	x 60L		65	x 65L
-30DZ		65	x 65L		70	x 70L
-35DZ		70	x 70L		75	x 75L
-40DZ		75	x 75L		80	x 80L
-45DZ		80	x 80L		85	x 85L
-50DZ		85	x 85L		90	x 90L
(N)CDQ2KB32-5DZ	8.5	50	CQ-M5 x 50L	10	50	CQ-M5 x 50L
-10DZ		55	x 55L		55	x 55L
-15DZ		60	x 60L		60	x 60L
-20DZ		65	x 65L		65	x 65L
-25DZ		70	x 70L		70	x 70L
-30DZ		75	x 75L		75	x 75L
-35DZ		80	x 80L		80	x 80L
-35DZ		85	x 80L		85	x 80L

Cylinder model	C	D	Bolt part no.	C'	D'	Bolt part no.
(N)CDQ2KB32-40DZ	8.5	85	CQ-M5 x 85L	10	85	CQ-M5 x 85L
-45DZ		90	x 90L		90	x 90L
-50DZ		95	x 95L		95	x 95L
-75DZ		120	x 120L		120	x 120L
-100DZ		145	x 145L		145	x 145L
(N)CDQ2KB40-5DZ	7.5	45	CQ-M5 x 45L	7.5	45	CQ-M5 x 45L
-10DZ		50	x 50L		50	x 50L
-15DZ		55	x 55L		55	x 55L
-20DZ		60	x 60L		60	x 60L
-25DZ		65	x 65L		65	x 65L
-30DZ		70	x 70L		70	x 70L
-35DZ		75	x 75L		75	x 75L
-40DZ		80	x 80L		80	x 80L
-45DZ		85	x 85L		85	x 85L
-50DZ		90	x 90L		90	x 90L
(N)CDQ2KB50-10DZ	12.5	55	CQ-M6 x 55L	12.5	55	CQ-M6 x 55L
-15DZ		60	x 60L		60	x 60L
-20DZ		65	x 65L		65	x 65L
-25DZ		70	x 70L		70	x 70L
-30DZ		75	x 75L		75	x 75L
-35DZ		80	x 80L		80	x 80L
-40DZ		85	x 85L		85	x 85L
-45DZ		90	x 90L		90	x 90L
-50DZ		95	x 95L		95	x 95L
-75DZ		120	x 120L		120	x 120L
(N)CDQ2KB63-10DZ	14.5	60	CQ-M8 x 60L	14.5	60	CQ-M8 x 60L
-15DZ		65	x 65L		65	x 65L
-20DZ		70	x 70L		70	x 70L
-25DZ		75	x 75L		75	x 75L
-30DZ		80	x 80L		80	x 80L
-35DZ		85	x 85L		85	x 85L
-40DZ		90	x 90L		90	x 90L
-45DZ		95	x 95L		95	x 95L
-50DZ		100	x 100L		100	x 100L
-75DZ		125	x 125L		125	x 125L
(N)CDQ2KB75-10DZ	15.0	150	x 150L	15.0	150	x 150L

Mounting Bolt for (N)CQ2B/Without Auto Switch

Mounting method: Mounting bolt for through-hole mounting of the CQ2B is available as an option. Refer to the following for ordering procedures. Order the actual number of bolts that will be used.

Example) CQ-M3x25L 4 pcs.

Material: Chromium molybdenum steel
 Surface treatment: Nickel plated

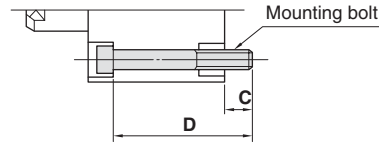
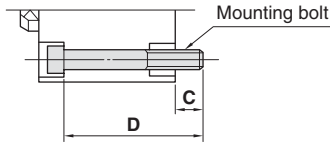

Spring Return

Cylinder model	C	D	Mounting bolt part no.
(N)CQ2B12-5S	6.5	25	CQ-M3 x 25L
-10S		30	x 30L
(N)CQ2B16-5S	5	25	CQ-M3 x 25L
-10S		30	x 30L
(N)CQ2B20-5S	7.5	25	CQ-M5 x 25L
-10S		30	x 30L
(N)CQ2B25-5S	9.5	30	CQ-M5 x 30L
-10S		35	x 35L
(N)CQ2B32-5SZ	9	30	CQ-M5 x 30L
-10SZ		35	x 35L
(N)CQ2B40-5SZ	7.5	35	CQ-M5 x 35L
-10SZ		40	x 40L
(N)CQ2B50-10SZ	12.5	45	CQ-M6 x 45L
-20SZ		55	x 55L

Spring Extend

Cylinder model	C	D	Mounting bolt part no.
(N)CQ2B12-5T	6.5	25	CQ-M3 x 25L
-10T		30	x 30L
(N)CQ2B16-5T	5	25	CQ-M3 x 25L
-10T		30	x 30L
(N)CQ2B20-5T	7.5	25	CQ-M5 x 25L
-10T		30	x 30L
(N)CQ2B25-5T	9.5	30	CQ-M5 x 30L
-10T		35	x 35L
(N)CQ2B32-5TZ	9	30	CQ-M5 x 30L
-10TZ		35	x 35L
(N)CQ2B40-5TZ	7.5	35	CQ-M5 x 35L
-10TZ		40	x 40L
(N)CQ2B50-10TZ	12.5	45	CQ-M6 x 45L
-20TZ		55	x 55L

- Standard
- Single Acting
- Double Rod
- Axial Piping
- Water Resistant
- High Lateral Load
- End Lock
- Clean Series
- Copper/Fluorine free series
- Construction and Parts
- Warranty and Operating Instructions
- Mounting and Auto Switches
- Made to Order

Series (N)CQ2^S_T Single Acting with Auto Switch

Mounting Bolt

Mounting Bolt for (N)CDQ2B/With Auto Switch

Mounting method: Mounting bolt for through-hole mounting of the CDQ2B is available as an option. Refer to the following for ordering procedures. Order the actual number of bolts that will be used.

Example) CQ-M3x35L 2 pcs.

Material: Chromium molybdenum steel
Surface treatment: Nickel plated

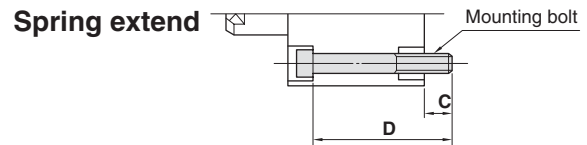
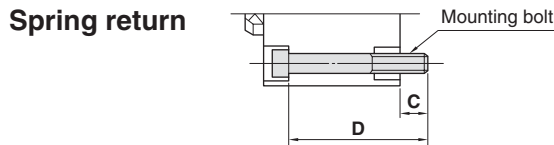

Spring Return

Cylinder model	C	D	Mounting bolt part no.
(N)CDQ2B12-5SZ	5.5	35	CQ-M3 x 35L
-10SZ		40	x 40L
(N)CDQ2B16-5SZ	8	40	CQ-M3 x 40L
-10SZ		45	x 45L
(N)CDQ2B20-5SZ	10.5	40	CQ-M5 x 40L
-10SZ		45	x 45L
(N)CDQ2B25-5SZ	9.5	40	CQ-M5 x 40L
-10SZ		45	x 45L
(N)CDQ2B32-5SZ	9	40	CQ-M5 x 40L
-10SZ		45	x 45L
(N)CDQ2B40-5SZ	7.5	45	CQ-M5 x 45L
-10SZ		50	x 50L
(N)CDQ2B50-10SZ	12.5	55	CQ-M6 x 55L
-20SZ		65	x 65L

Spring Extend

Cylinder model	C	D	Mounting bolt part no.
(N)CDQ2B12-5TZ	6.1	40	CQ-M3 x 40L
-10TZ		45	x 45L
(N)CDQ2B16-5TZ	8	40	CQ-M3 x 40L
-10TZ		45	x 45L
(N)CDQ2B20-5TZ	10.5	40	CQ-M5 x 40L
-10TZ		45	x 45L
(N)CDQ2B25-5TZ	9.5	40	CQ-M5 x 40L
-10TZ		45	x 45L
(N)CDQ2B32-5TZ	9	40	CQ-M5 x 40L
-10TZ		45	x 45L
(N)CDQ2B40-5TZ	7.5	45	CQ-M5 x 45L
-10TZ		50	x 50L
(N)CDQ2B50-10TZ	12.5	55	CQ-M6 x 55L
-20TZ		65	x 65L

Mounting Bolt for (N)CQ2WB/Without Auto Switch

Mounting method: Mounting bolt for through-hole mounting of the CQ2WB is available as an option. Refer to the following for ordering procedures. Order the actual number of bolts that will be used.

Example) CQ-M3x35L 4 pcs.

Material: Chromium molybdenum steel
Surface treatment: Nickel plated

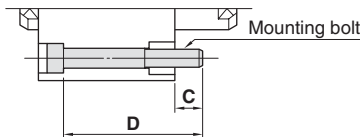

Cylinder model	C	D	Bolt part no.
(N)CQ2WB12-5D	8.3	35	CQ-M3 x 35L
-10D		40	x 40L
-15D		45	x 45L
-20D		50	x 50L
-25D		55	x 55L
-30D		60	x 60L
(N)CQ2WB16-5D	7.5	35	CQ-M3 x 35L
-10D		40	x 40L
-15D		45	x 45L
-20D		50	x 50L
-25D		55	x 55L
-30D		60	x 60L
(N)CQ2WB20-5D	6	30	CQ-M5 x 30L
-10D		35	x 35L
-15D		40	x 40L
-20D		45	x 45L
-25D		50	x 50L
-30D		55	x 55L
-35D	60	x 60L	
-40D	65	x 65L	
-45D	70	x 70L	
-50D	75	x 75L	
(N)CQ2WB25-5D	8	35	CQ-M5 x 35L
-10D		40	x 40L
-15D		45	x 45L
-20D		50	x 50L
-25D		55	x 55L
-30D		60	x 60L
-35D	65	x 65L	
-40D	70	x 70L	
-45D	75	x 75L	
-50D	80	x 80L	

Cylinder model	C	D	Bolt part no.
(N)CQ2WB32-5DZ	6.5	35	CQ-M5 x 35L
-10DZ		40	x 40L
-15DZ		45	x 45L
-20DZ		50	x 50L
-25DZ		55	x 55L
-30DZ		60	x 60L
-35DZ	65	x 65L	
-40DZ	70	x 70L	
-45DZ	75	x 75L	
-50DZ	80	x 80L	
-75DZ	115	x 115L	
-100DZ	140	x 140L	
(N)CQ2WB40-5DZ	7	45	CQ-M5 x 45L
-10DZ		50	x 50L
-15DZ		55	x 55L
-20DZ		60	x 60L
-25DZ		65	x 65L
-30DZ		70	x 70L
-35DZ	75	x 75L	
-40DZ	80	x 80L	
-45DZ	85	x 85L	
-50DZ	90	x 90L	
-75DZ	125	x 125L	
-100DZ	150	x 150L	
(N)CQ2WB50-10DZ	12.5	55	CQ-M6 x 55L
-15DZ		60	x 60L
-20DZ		65	x 65L
-25DZ		70	x 70L
-30DZ		75	x 75L
-35DZ		80	x 80L
-40DZ	85	x 85L	
-45DZ	90	x 90L	
-50DZ	95	x 95L	
-75DZ	130	x 130L	
-100DZ	155	x 155L	

Cylinder model	C	D	Bolt part no.
(N)CQ2WB63-10DZ	13.5	55	CQ-M8 x 55L
-15DZ		60	x 60L
-20DZ		65	x 65L
-25DZ		70	x 70L
-30DZ		75	x 75L
-35DZ		80	x 80L
-40DZ	85	x 85L	
-45DZ	90	x 90L	
-50DZ	95	x 95L	
-75DZ	130	x 130L	
-100DZ	155	x 155L	
CQ2WB80-10DZ	12.5	60	CQ-M10 x 60L
-15DZ		65	x 65L
-20DZ		70	x 70L
-25DZ		75	x 75L
-30DZ		80	x 80L
-35DZ		85	x 85L
-40DZ	90	x 90L	
-45DZ	95	x 95L	
-50DZ	100	x 100L	
-75DZ	135	x 135L	
-100DZ	160	x 160L	
(N)CQ2WB100-10DZ	13	70	CQ-M10 x 70L
-15DZ		75	x 75L
-20DZ		80	x 80L
-25DZ		85	x 85L
-30DZ		90	x 90L
-35DZ		95	x 95L
-40DZ	100	x 100L	
-45DZ	105	x 105L	
-50DZ	110	x 110L	
-75DZ	145	x 145L	
-100DZ	170	x 170L	

- Standard
- Single Acting
- Double Rod
- Axial Piping
- Water Resistant
- High Lateral Load
- End Lock
- Clean Series
- Copper/Fluorine free series
- Construction and Parts
- Warranty and Operating Instructions
- Mounting and Auto Switches
- Made to Order

Mounting Bolt for (N)CDQ2WB/With Auto Switch

Mounting method: Mounting bolt for through-hole mounting of the CDQ2WB is available as an option. Refer to the following for ordering procedures. Order the actual number of bolts that will be used.

Example) CQ-M3x40L 2 pcs.

Material: Chromium molybdenum steel
Surface treatment: Nickel plated

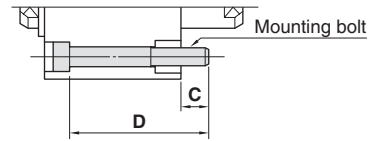

Cylinder model	C	D	Bolt part no.
(N)CDQ2WB12-5DCZ	6.1	40	CQ-M3 x 40L
-10DCZ		45	x 45L
-15DCZ		50	x 50L
-20DCZ		55	x 55L
-25DCZ		60	x 60L
-30DCZ		65	x 65L
(N)CDQ2WB16-5DZ	7.5	45	CQ-M3 x 45L
-10DZ		50	x 50L
-15DZ		55	x 55L
-20DZ		60	x 60L
-25DZ		65	x 65L
-30DZ		70	x 70L
(N)CDQ2WB20-5DZ	9	45	CQ-M5 x 45L
-10DZ		50	x 50L
-15DZ		55	x 55L
-20DZ		60	x 60L
-25DZ		65	x 65L
-30DZ		70	x 70L
-35DZ		75	x 75L
-40DZ		80	x 80L
-45DZ		85	x 85L
-50DZ		90	x 90L
(N)CDQ2WB25-5DZ	8	45	CQ-M5 x 45L
-10DZ		50	x 50L
-15DZ		55	x 55L
-20DZ		60	x 60L
-25DZ		65	x 65L
-30DZ		70	x 70L
-35DZ		75	x 75L
-40DZ		80	x 80L
-45DZ		85	x 85L
-50DZ		90	x 90L

Cylinder model	C	D	Bolt part no.
(N)CDQ2WB32-5DZ	6.5	45	CQ-M5 x 45L
-10DZ		50	x 50L
-15DZ		55	x 55L
-20DZ		60	x 60L
-25DZ		65	x 65L
-30DZ		70	x 70L
-35DZ		75	x 75L
-40DZ		80	x 80L
-45DZ		85	x 85L
-50DZ		90	x 90L
(N)CDQ2WB40-5DZ	7	55	CQ-M5 x 55L
-10DZ		60	x 60L
-15DZ		65	x 65L
-20DZ		70	x 70L
-25DZ		75	x 75L
-30DZ		80	x 80L
-35DZ		85	x 85L
-40DZ		90	x 90L
-45DZ		95	x 95L
-50DZ		100	x 100L
(N)CDQ2WB50-10DZ	12.5	65	CQ-M6 x 65L
-15DZ		70	x 70L
-20DZ		75	x 75L
-25DZ		80	x 80L
-30DZ		85	x 85L
-35DZ		90	x 90L
-40DZ		95	x 95L
-45DZ		100	x 100L
-50DZ		105	x 105L
-75DZ		130	x 130L
-100DZ	155	x 155L	

Cylinder model	C	D	Bolt part no.
(N)CDQ2WB63-10DZ	13.5	65	CQ-M8 x 65L
-15DZ		70	x 70L
-20DZ		75	x 75L
-25DZ		80	x 80L
-30DZ		85	x 85L
-35DZ		90	x 90L
-40DZ		95	x 95L
-45DZ		100	x 100L
-50DZ		105	x 105L
-75DZ		130	x 130L
(N)CDQ2WB80-10DZ	12.5	70	CQ-M10 x 70L
-15DZ		75	x 75L
-20DZ		80	x 80L
-25DZ		85	x 85L
-30DZ		90	x 90L
-35DZ		95	x 95L
-40DZ		100	x 100L
-45DZ		105	x 105L
-50DZ		110	x 110L
-75DZ		135	x 135L
(N)CDQ2WB100-10DZ	13	80	CQ-M10 x 80L
-15DZ		85	x 85L
-20DZ		90	x 90L
-25DZ		95	x 95L
-30DZ		100	x 100L
-35DZ		105	x 105L
-40DZ		110	x 110L
-45DZ		115	x 115L
-50DZ		120	x 120L
-75DZ		145	x 145L
-100DZ	170	x 170L	

Mounting Bolt for (N)CQ2WB

Mounting method: Mounting bolt for through-hole mounting of the CQ2WB is available as an option. Refer to the following for ordering procedures. Order the actual number of bolts that will be used.

Example) CQ-M12x100L 4 pcs.

- Note 1) To install a through-hole type mounting bolt, make sure to use the flat washer that is provided.
- Note 2) For mounting bolts for the stroke length exceeding 100 mm, use the OA screw provided on the cylinder tube to secure the cylinder.

Material: Chromium molybdenum steel
Surface treatment: Nickel plated

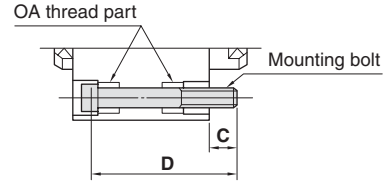

Cylinder model	C	D	Mounting bolt part no.
(N)C□Q2WB125/140-10DCZ	22.9	100	CQ-M12 x 100L
-20DCZ		110	x 110L
-30DCZ		120	x 120L
-40DCZ		130	x 130L
-50DCZ		140	x 140L
-75DCZ		165	x 165L
-100DCZ		190	x 190L
(N)C□Q2WB160-10DCZ	27.7	110	CQ-M14 x 110L
-20DCZ		120	x 120L
-30DCZ		130	x 130L
-40DCZ		140	x 140L
-50DCZ		150	x 150L
-75DCZ		175	x 175L
-100DCZ	200	x 200L	

Cylinder model	C	D	Mounting bolt part no.
(N)C□Q2WB180-10DCZ	36	125	CQ-M18 x 125L
-20DCZ		135	x 135L
-30DCZ		145	x 145L
-40DCZ		155	x 155L
-50DCZ		165	x 165L
-75DCZ		190	x 190L
-100DCZ		215	x 215L
(N)C□Q2WB200-10DCZ	39	135	CQ-M18 x 135L
-20DCZ		145	x 145L
-30DCZ		155	x 155L
-40DCZ		165	x 165L
-50DCZ		175	x 175L
-75DCZ		200	x 200L
-100DCZ	225	x 225L	

- Standard
- Single Acting
- Double Rod
- Axial Piping
- Water Resistant
- High Lateral Load
- End Lock
- Clean Series
- Copper/Fluorine free series
- Construction and Parts
- Warranty and Operating Instructions
- Mounting and Auto Switches
- Made to Order

Mounting Bolt for (N)CQ2KWB/Without Auto Switch

Mounting method: Mounting bolt for through-hole mounting of the CQ2KWB is available as an option. Refer to the following for ordering procedures. Order the actual number of bolts that will be used.

Example) CQ-M3x40L 2 pcs.

Material: Chromium molybdenum steel
Surface treatment: Nickel plated

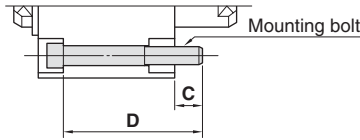

Non-rotating rod end mounting

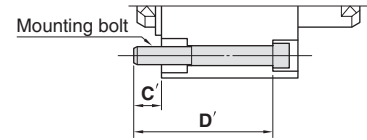

Cylinder model	C	D	Bolt part no.	C'	D'	Bolt part no.
(N)CQ2KWB12-5D	8.3	40	CQ-M3 x 40L	8.3	40	CQ-M3 x 40L
-10D		45	x 45L		45	x 45L
-15D		50	x 50L		50	x 50L
-20D		55	x 55L		55	x 55L
-25D		60	x 60L		60	x 60L
-30D		65	x 65L		65	x 65L
(N)CQ2KWB16-5D	7.5	40	CQ-M3 x 40L	7.5	40	CQ-M3 x 40L
-10D		45	x 45L		45	x 45L
-15D		50	x 50L		50	x 50L
-20D		55	x 55L		55	x 55L
-25D		60	x 60L		60	x 60L
-30D		65	x 65L		65	x 65L
(N)CQ2KWB20-5D	6.5	40	CQ-M5 x 40L	8	40	CQ-M5 x 40L
-10D		45	x 45L		45	x 45L
-15D		50	x 50L		50	x 50L
-20D		55	x 55L		55	x 55L
-25D		60	x 60L		60	x 60L
-30D		65	x 65L		65	x 65L
-35D		70	x 70L		70	x 70L
-40D		75	x 75L		75	x 75L
-45D		80	x 80L		80	x 80L
-50D		85	x 85L		85	x 85L
(N)CQ2KWB25-5D	8.5	45	CQ-M5 x 45L	10	45	CQ-M5 x 45L
-10D		50	x 50L		50	x 50L
-15D		55	x 55L		55	x 55L
-20D		60	x 60L		60	x 60L
-25D		65	x 65L		65	x 65L
-30D		70	x 70L		70	x 70L
-35D		75	x 75L		75	x 75L
-40D		80	x 80L		80	x 80L
-45D		85	x 85L		85	x 85L
-50D		90	x 90L		90	x 90L
(N)CQ2KWB32-5DZ	11	50	CQ-M5 x 50L	7.5	45	CQ-M5 x 45L
-10DZ		55	x 55L		50	x 50L
-15DZ		60	x 60L		55	x 55L
-20DZ		65	x 65L		60	x 60L
-25DZ		70	x 70L		65	x 65L
-30DZ		75	x 75L		70	x 70L
-35DZ		80	x 80L		75	x 75L
-40DZ		85	x 85L		80	x 80L
-45DZ		90	x 90L		85	x 85L
-50DZ		95	x 95L		90	x 90L
-75DZ		130	x 130L		125	x 125L
-100DZ		155	x 155L		150	x 150L

Cylinder model	C	D	Bolt part no.
(N)CQ2KWB40-5DZ	7	45	CQ-M5 x 45L
-10DZ		50	x 50L
-15DZ		55	x 55L
-20DZ		60	x 60L
-25DZ		65	x 65L
-30DZ		70	x 70L
-35DZ		75	x 75L
-40DZ		80	x 80L
-45DZ		85	x 85L
-50DZ		90	x 90L
-75DZ	125	x 125L	
-100DZ	150	x 150L	
(N)CQ2KWB50-10DZ	12.5	55	CQ-M6 x 55L
-15DZ		60	x 60L
-20DZ		65	x 65L
-25DZ		70	x 70L
-30DZ		75	x 75L
-35DZ		80	x 80L
-40DZ		85	x 85L
-45DZ		90	x 90L
-50DZ		95	x 95L
-75DZ		130	x 130L
-100DZ	155	x 155L	
(N)CQ2KWB63-10DZ	13.5	55	CQ-M8 x 55L
-15DZ		60	x 60L
-20DZ		65	x 65L
-25DZ		70	x 70L
-30DZ		75	x 75L
-35DZ		80	x 80L
-40DZ		85	x 85L
-45DZ		90	x 90L
-50DZ		95	x 95L
-75DZ		130	x 130L
-100DZ	155	x 155L	

* $\phi 40$ to $\phi 63$: The C' and D' dimensions are the same as those of C and D.

Mounting Bolt for (N)CDQ2KWB/With Auto Switch

Mounting method: Mounting bolt for through-hole mounting of the CDQ2KWB is available as an option. Refer to the following for ordering procedures. Order the actual number of bolts that will be used.

Example) CQ-M3x40L 2 pcs.

Material: Chromium molybdenum steel
Surface treatment: Nickel plated

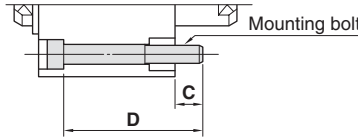

Non-rotating rod end mounting

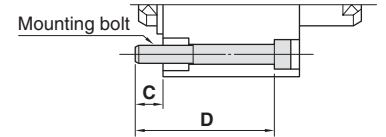

Cylinder model	C	D	Bolt part no.	C'	D'	Bolt part no.
(N)CDQ2KWB12-5DCZ	6.1	40	CQ-M3 x 40L	6.1	45	CQ-M3 x 45L
-10DCZ		45	x 45L		50	x 50L
-15DCZ		50	x 50L		55	x 55L
-20DCZ		55	x 55L		60	x 60L
-25DCZ		60	x 60L		65	x 65L
-30DCZ	65	x 65L	70	x 70L		
(N)CDQ2KWB16-5DZ	7.5	45	CQ-M3 x 45L	7.5	50	CQ-M3 x 50L
-10DZ		50	x 50L		55	x 55L
-15DZ		55	x 55L		60	x 60L
-20DZ		60	x 60L		65	x 65L
-25DZ		65	x 65L		70	x 70L
-30DZ	70	x 70L	75	x 75L		
(N)CDQ2KWB20-5DZ	9	45	CQ-M5 x 45L	11	55	CQ-M5 x 55L
-10DZ		50	x 50L		60	x 60L
-15DZ		55	x 55L		65	x 65L
-20DZ		60	x 60L		70	x 70L
-25DZ		65	x 65L		75	x 75L
-30DZ		70	x 70L		80	x 80L
-35DZ		75	x 75L		85	x 85L
-40DZ		80	x 80L		90	x 90L
-45DZ		85	x 85L		95	x 95L
-50DZ		90	x 90L		100	x 100L
(N)CDQ2KWB25-5DZ	8	45	CQ-M5 x 45L	10	55	CQ-M5 x 55L
-10DZ		50	x 50L		60	x 60L
-15DZ		55	x 55L		65	x 65L
-20DZ		60	x 60L		70	x 70L
-25DZ		65	x 65L		75	x 75L
-30DZ		70	x 70L		80	x 80L
-35DZ		75	x 75L		85	x 85L
-40DZ		80	x 80L		90	x 90L
-45DZ		85	x 85L		95	x 95L
-50DZ		90	x 90L		100	x 100L
(N)CDQ2KWB32-5DZ	11	60	CQ-M5 x 60L	7.5	55	CQ-M5 x 55L
-10DZ		65	x 65L		60	x 60L
-15DZ		70	x 70L		65	x 65L
-20DZ		75	x 75L		70	x 70L
-25DZ		80	x 80L		75	x 75L
-30DZ		85	x 85L		80	x 80L
-35DZ		90	x 90L		85	x 85L
-40DZ		95	x 95L		90	x 90L
-45DZ		100	x 100L		95	x 95L
-50DZ		105	x 105L		100	x 100L
-75DZ	130	x 130L	125	x 125L		
-100DZ	155	x 155L	150	x 150L		

Cylinder model	C	D	Bolt part no.
(N)CDQ2KWB40-5DZ	7	55	CQ-M5 x 55L
-10DZ		60	x 60L
-15DZ		65	x 65L
-20DZ		70	x 70L
-25DZ		75	x 75L
-30DZ		80	x 80L
-35DZ		85	x 85L
-40DZ		90	x 90L
-45DZ		95	x 95L
-50DZ		100	x 100L
-75DZ	125	x 125L	
-100DZ	150	x 150L	
(N)CDQ2KWB50-10DZ	12.5	65	CQ-M6 x 65L
-15DZ		70	x 70L
-20DZ		75	x 75L
-25DZ		80	x 80L
-30DZ		85	x 85L
-35DZ		90	x 90L
-40DZ		95	x 95L
-45DZ		100	x 100L
-50DZ		105	x 105L
-75DZ		130	x 130L
-100DZ	155	x 155L	
(N)CDQ2KWB63-10DZ	13.5	65	CQ-M8 x 65L
-15DZ		70	x 70L
-20DZ		75	x 75L
-25DZ		80	x 80L
-30DZ		85	x 85L
-35DZ		90	x 90L
-40DZ		95	x 95L
-45DZ		100	x 100L
-50DZ		105	x 105L
-75DZ		130	x 130L
-100DZ	155	x 155L	

* ø40 to ø63: The C' and D' dimensions are the same as those of C and D.

- Standard
- Single Acting
- Double Rod
- Axial Piping
- Water Resistant
- High Lateral Load
- End Lock
- Clean Series
- Copper/Fluorine free series
- Construction and Parts
- Warranty and Operating Instructions
- Mounting and Auto Switches
- Made to Order

Series CQP2 Axial Piping Mounting Bolt

Mounting Bolt for CQP2B/Without Auto Switch

Mounting method: Mounting bolt for through-hole mounting of the CQP2B is available as an option. Refer to the following for ordering procedures. Order the actual number of bolts that will be used.

Example) CQ-M3x25L 2 pcs.

Material: Chromium molybdenum steel
Surface treatment: Nickel plated

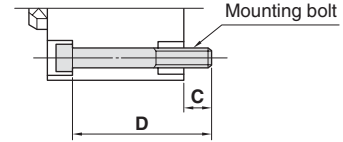

Cylinder model	C	D	Bolt part no.
CQP2B12-5D	6.5	25	CQ-M3 x 25L
-10D		30	x 30L
-15D		35	x 35L
-20D		40	x 40L
-25D		45	x 45L
-30D		50	x 50L
CQP2B16-5D	5	25	CQ-M3 x 25L
-10D		30	x 30L
-15D		35	x 35L
-20D		40	x 40L
-25D		45	x 45L
-30D		50	x 50L
CQP2B20-5D	7.5	25	CQ-M5 x 25L
-10D		30	x 30L
-15D		35	x 35L
-20D		40	x 40L
-25D		45	x 45L
-30D		50	x 50L
-35D		55	x 55L
-40D		60	x 60L
-45D		65	x 65L
-50D		70	x 70L
CQP2B25-5D	9.5	30	CQ-M5 x 30L
-10D		35	x 35L
-15D		40	x 40L
-20D		45	x 45L
-25D		50	x 50L
-30D		55	x 55L
-35D		60	x 60L
-40D		65	x 65L
-45D		70	x 70L
-50D		75	x 75L

Cylinder model	C	D	Bolt part no.
CQP2B32-5D	9	30	CQ-M5 x 30L
-10D		35	x 35L
-15D		40	x 40L
-20D		45	x 45L
-25D		50	x 50L
-30D		55	x 55L
-35D		60	x 60L
-40D		65	x 65L
-45D		70	x 70L
-50D		75	x 75L
-75D	110	x 110L	
-100D	135	x 135L	
CQP2B40-5D	7.5	35	CQ-M5 x 35L
-10D		40	x 40L
-15D		45	x 45L
-20D		50	x 50L
-25D		55	x 55L
-30D		60	x 60L
-35D		65	x 65L
-40D		70	x 70L
-45D		75	x 75L
-50D		80	x 80L
-75D	115	x 115L	
-100D	140	x 140L	
CQP2B50-10D	12.5	45	CQ-M6 x 45L
-15D		50	x 50L
-20D		55	x 55L
-25D		60	x 60L
-30D		65	x 65L
-35D		70	x 70L
-40D		75	x 75L
-45D		80	x 80L
-50D		85	x 85L
-75D		120	x 120L
-100D	145	x 145L	

Cylinder model	C	D	Bolt part no.
CQP2B63-10D	14.5	50	CQ-M8 x 50L
-15D		55	x 55L
-20D		60	x 60L
-25D		65	x 65L
-30D		70	x 70L
-35D		75	x 75L
-40D		80	x 80L
-45D		85	x 85L
-50D		90	x 90L
-75D		125	x 125L
-100D	150	x 150L	
CQP2B80-10D	15	55	CQ-M10 x 55L
-15D		60	x 60L
-20D		65	x 65L
-25D		70	x 70L
-30D		75	x 75L
-35D		80	x 80L
-40D		85	x 85L
-45D		90	x 90L
-50D		95	x 95L
-75D		130	x 130L
-100D	155	x 155L	
CQP2B100-10D	15.5	65	CQ-M10 x 65L
-15D		70	x 70L
-20D		75	x 75L
-25D		80	x 80L
-30D		85	x 85L
-35D		90	x 90L
-40D		95	x 95L
-45D		100	x 100L
-50D		105	x 105L
-75D		140	x 140L
-100D	165	x 165L	

Mounting Bolt for CDQP2B/With Auto Switch

Mounting method: Mounting bolt for through-hole mounting of the CDQP2B is available as an option. Refer to the following for ordering procedures. Order the actual number of bolts that will be used.

Material: Chromium molybdenum steel
Surface treatment: Nickel plated

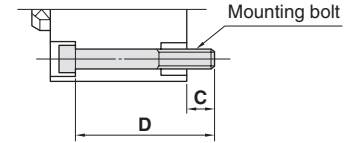

Example) CQ-M3x35L 2 pcs.

Cylinder model	C	D	Bolt part no.
CDQP2B12-5D	5.5	35	CQ-M3 x 35L
-10D		40	x 40L
-15D		45	x 45L
-20D		50	x 50L
-25D		55	x 55L
-30D		60	x 60L
CDQP2B16-5D	8	40	CQ-M3 x 40L
-10D		45	x 45L
-15D		50	x 50L
-20D		55	x 55L
-25D		60	x 60L
-30D		65	x 65L
CDQP2B20-5D	10.5	40	CQ-M5 x 40L
-10D		45	x 45L
-15D		50	x 50L
-20D		55	x 55L
-25D		60	x 60L
-30D		65	x 65L
-35D		70	x 70L
-40D		75	x 75L
-45D		80	x 80L
-50D		85	x 85L
CDQP2B25-5D	9.5	40	CQ-M5 x 40L
-10D		45	x 45L
-15D		50	x 50L
-20D		55	x 55L
-25D		60	x 60L
-30D		65	x 65L
-35D		70	x 70L
-40D		75	x 75L
-45D		80	x 80L
-50D		85	x 85L

Cylinder model	C	D	Bolt part no.
CDQP2B32-5D	9	40	CQ-M5 x 40L
-10D		45	x 45L
-15D		50	x 50L
-20D		55	x 55L
-25D		60	x 60L
-30D		65	x 65L
-35D		70	x 70L
-40D		75	x 75L
-45D		80	x 80L
-50D		85	x 85L
CDQP2B40-5D	7.5	45	CQ-M5 x 45L
-10D		50	x 50L
-15D		55	x 55L
-20D		60	x 60L
-25D		65	x 65L
-30D		70	x 70L
-35D		75	x 75L
-40D		80	x 80L
-45D		85	x 85L
-50D		90	x 90L
CDQP2B50-10D	12.5	55	CQ-M6 x 55L
-15D		60	x 60L
-20D		65	x 65L
-25D		70	x 70L
-30D		75	x 75L
-35D		80	x 80L
-40D		85	x 85L
-45D		90	x 90L
-50D		95	x 95L
-75D		120	x 120L
-100D	145	x 145L	

Cylinder model	C	D	Bolt part no.
CDQP2B63-10D	14.5	60	CQ-M8 x 60L
-15D		65	x 65L
-20D		70	x 70L
-25D		75	x 75L
-30D		80	x 80L
-35D		85	x 85L
-40D		90	x 90L
-45D		95	x 95L
-50D		100	x 100L
-75D		125	x 125L
CDQP2B80-10D	15	65	CQ-M10 x 65L
-15D		70	x 70L
-20D		75	x 75L
-25D		80	x 80L
-30D		85	x 85L
-35D		90	x 90L
-40D		95	x 95L
-45D		100	x 100L
-50D		105	x 105L
-75D		130	x 130L
CDQP2B100-10D	15.5	75	CQ-M10 x 75L
-15D		80	x 80L
-20D		85	x 85L
-25D		90	x 90L
-30D		95	x 95L
-35D		100	x 100L
-40D		105	x 105L
-45D		110	x 110L
-50D		115	x 115L
-75D		140	x 140L
-100D	165	x 165L	

- Standard
- Single Acting
- Double Rod
- Axial Piping
- Water Resistant
- High Lateral Load
- End Lock
- Clean Series
- Copper/Fluorine free series
- Construction and Parts
- Warranty and Operating Instructions
- Mounting and Auto Switches
- Made to Order

Mounting Bolt for CQP2B/Without Auto Switch

Mounting method: Mounting bolt for through-hole mounting of the CQP2B is available as an option. Refer to the following for ordering procedures. Order the actual number of bolts that will be used.

Example) CQ-M3x25L 2 pcs.

Material: Chromium molybdenum steel
 Surface treatment: Nickel plated

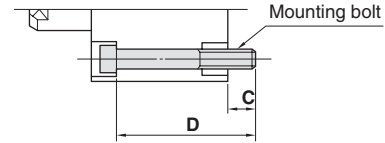
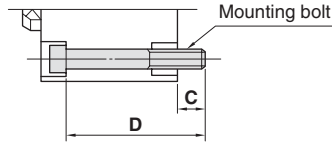

Spring Return

Cylinder model	C	D	Mounting bolt part no.
CQP2B12-5S	6.5	25	CQ-M3 x 25L
-10S		30	x 30L
CQP2B16-5S	5	25	CQ-M3 x 25L
-10S		30	x 30L
CQP2B20-5S	7.5	25	CQ-M5 x 25L
-10S		30	x 30L
CQP2B25-5S	9.5	30	CQ-M5 x 30L
-10S		35	x 35L
CQP2B32-5S	9	30	CQ-M5 x 30L
-10S		35	x 35L
CQP2B40-5S	7.5	35	CQ-M5 x 35L
-10S		40	x 40L
CQP2B50-10S	12.5	45	CQ-M6 x 45L
-20S		55	x 55L

Spring Extend

Cylinder model	C	D	Mounting bolt part no.
CQP2B12-5T	6.5	25	CQ-M3 x 25L
-10T		30	x 30L
CQP2B16-5T	5	25	CQ-M3 x 25L
-10T		30	x 30L
CQP2B20-5T	7.5	25	CQ-M5 x 25L
-10T		30	x 30L
CQP2B25-5T	9.5	30	CQ-M5 x 30L
-10T		35	x 35L
CQP2B32-5T	9	30	CQ-M5 x 30L
-10T		35	x 35L
CQP2B40-5T	7.5	35	CQ-M5 x 35L
-10T		40	x 40L
CQP2B50-10T	12.5	45	CQ-M6 x 45L
-20T		55	x 55L

Mounting Bolt for CDQP2B/With Auto Switch

Mounting method: Mounting bolt for through-hole mounting of the CDQP2B is available as an option. Refer to the following for ordering procedures. Order the actual number of bolts that will be used.

Example) CQ-M3x35L 2 pcs.

Material: Chromium molybdenum steel
Surface treatment: Nickel plated

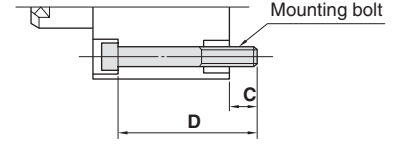
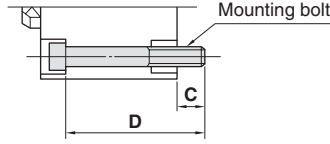

Spring Return

Cylinder model	C	D	Mounting bolt part no.
CDQP2B12-5S	5.5	35	CQ-M3 x 35L
-10S		40	x 40L
CDQP2B16-5S	8	40	CQ-M3 x 40L
-10S		45	x 45L
CDQP2B20-5S	10.5	40	CQ-M5 x 40L
-10S		45	x 45L
CDQP2B25-5S	9.5	40	CQ-M5 x 40L
-10S		45	x 45L
CDQP2B32-5S	9	40	CQ-M5 x 40L
-10S		45	x 45L
CDQP2B40-5S	7.5	45	CQ-M5 x 45L
-10S		50	x 50L
CDQP2B50-10S	12.5	55	CQ-M6 x 55L
-20S		60	x 60L

Spring Extend

Cylinder model	C	D	Mounting bolt part no.
CDQP2B12-5T	6.1	40	CQ-M3 x 40L
-10T		45	x 45L
CDQP2B16-5T	8	40	CQ-M3 x 40L
-10T		45	x 45L
CDQP2B20-5T	10.5	40	CQ-M5 x 40L
-10T		45	x 45L
CDQP2B25-5T	9.5	40	CQ-M5 x 40L
-10T		45	x 45L
CDQP2B32-5T	9	40	CQ-M5 x 40L
-10T		45	x 45L
CDQP2B40-5T	7.5	45	CQ-M5 x 45L
-10T		50	x 50L
CDQP2B50-10T	12.5	55	CQ-M6 x 55L
-20T		65	x 65L

- Standard
- Single Acting
- Double Rod
- Axial Piping
- Water Resistant
- High Lateral Load
- End Lock
- Clean Series
- Copper/Fluorine free series
- Construction and Parts
- Warranty and Operating Instructions
- Mounting and Auto Switches**
- Made to Order

Series CQ2 S High Lateral Load Mounting Bolt

Mounting Bolt for CQ2BS/Without Auto Switch

Mounting method: Mounting bolt for through-hole mounting of the CQ2BS is available as an option. Refer to the following for ordering procedures. Order the actual number of bolts that will be used.

Example) CQ-M5x40L 4 pcs.

Material: Chromium molybdenum steel
Surface treatment: Nickel plated

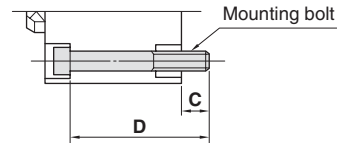

Cylinder model	C	D	Mounting bolt part no.
CQ2BS32-5DCZ	9	40	CQ-M5 x 40L
-10DCZ		45	x 45L
-15DCZ		50	x 50L
-20DCZ		55	x 55L
-25DCZ		60	x 60L
-30DCZ		65	x 65L
-35DCZ		70	x 70L
-40DCZ		75	x 75L
-45DCZ		80	x 80L
-50DCZ		85	x 85L
-75DCZ		120	x 120L
-100DCZ		145	x 145L
CQ2BS40-5DCZ	7.5	45	CQ-M5 x 45L
-10DCZ		50	x 50L
-15DCZ		55	x 55L
-20DCZ		60	x 60L
-25DCZ		65	x 65L
-30DCZ		70	x 70L
-35DCZ		75	x 75L
-40DCZ		80	x 80L
-45DCZ		85	x 85L
-50DCZ		90	x 90L
-75DCZ		125	x 125L
-100DCZ		150	x 150L
CQ2BS50-10DCZ	12.5	55	CQ-M6 x 55L
-15DCZ		60	x 60L
-20DCZ		65	x 65L
-25DCZ		70	x 70L
-30DCZ		75	x 75L
-35DCZ		80	x 80L
-40DCZ		85	x 85L
-45DCZ		90	x 90L
-50DCZ		95	x 95L
-75DCZ		130	x 130L
-100DCZ		155	x 155L

Cylinder model	C	D	Mounting bolt part no.
CQ2BS63-10DCZ	14.5	60	CQ-M8 x 60L
-15DCZ		65	x 65L
-20DCZ		70	x 70L
-25DCZ		75	x 75L
-30DCZ		80	x 80L
-35DCZ		85	x 85L
-40DCZ		90	x 90L
-45DCZ		95	x 95L
-50DCZ		100	x 100L
-75DCZ		135	x 135L
-100DCZ		160	x 160L
CQ2BS80-10DCZ		15	65
-15DCZ	70		x 70L
-20DCZ	75		x 75L
-25DCZ	80		x 80L
-30DCZ	85		x 85L
-35DCZ	90		x 90L
-40DCZ	95		x 95L
-45DCZ	100		x 100L
-50DCZ	105		x 105L
-75DCZ	140		x 140L
-100DCZ	165		x 165L
CQ2BS100-10DCZ	15.5		75
-15DCZ		80	x 80L
-20DCZ		85	x 85L
-25DCZ		90	x 90L
-30DCZ		95	x 95L
-35DCZ		100	x 100L
-40DCZ		105	x 105L
-45DCZ		110	x 110L
-50DCZ		115	x 115L
-75DCZ		150	x 150L
-100DCZ		175	x 175L

Mounting Bolt for CDQ2BS/With Auto Switch

Mounting method: Mounting bolt for through-hole mounting of the CDQ2BS is available as an option. Refer to the following for ordering procedures. Order the actual number of bolts that will be used.

Example) CQ-M5x50L 4 pcs.

Material: Chromium molybdenum steel
Surface treatment: Nickel plated

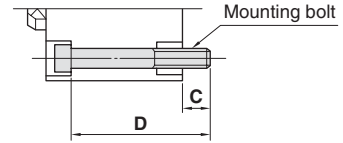

Cylinder model	C	D	Mounting bolt part no.
CDQ2BS32-5DCZ	9	50	CQ-M5 x 50L
-10DCZ		55	x 55L
-15DCZ		60	x 60L
-20DCZ		65	x 65L
-25DCZ		70	x 70L
-30DCZ		75	x 75L
-35DCZ		80	x 80L
-40DCZ		85	x 85L
-45DCZ		90	x 90L
-50DCZ		95	x 95L
-75DCZ		120	x 120L
-100DCZ		145	x 145L
CDQ2BS40-5DCZ	7.5	55	CQ-M5 x 55L
-10DCZ		60	x 60L
-15DCZ		65	x 65L
-20DCZ		70	x 70L
-25DCZ		75	x 75L
-30DCZ		80	x 80L
-35DCZ		85	x 85L
-40DCZ		90	x 90L
-45DCZ		95	x 95L
-50DCZ		100	x 100L
-75DCZ		125	x 125L
-100DCZ		150	x 150L
CDQ2BS50-10DCZ	12.5	65	CQ-M6 x 65L
-15DCZ		70	x 70L
-20DCZ		75	x 75L
-25DCZ		80	x 80L
-30DCZ		85	x 85L
-35DCZ		90	x 90L
-40DCZ		95	x 95L
-45DCZ		100	x 100L
-50DCZ		105	x 105L
-75DCZ		130	x 130L
-100DCZ		155	x 155L

Cylinder model	C	D	Mounting bolt part no.
CDQ2BS63-10DCZ	14.5	70	CQ-M8 x 70L
-15DCZ		75	x 75L
-20DCZ		80	x 80L
-25DCZ		85	x 85L
-30DCZ		90	x 90L
-35DCZ		95	x 95L
-40DCZ		100	x 100L
-45DCZ		105	x 105L
-50DCZ		110	x 110L
-75DCZ		135	x 135L
-100DCZ		160	x 160L
CDQ2BS80-10DCZ		15	75
-15DCZ	80		x 80L
-20DCZ	85		x 85L
-25DCZ	90		x 90L
-30DCZ	95		x 95L
-35DCZ	100		x 100L
-40DCZ	105		x 105L
-45DCZ	110		x 110L
-50DCZ	115		x 115L
-75DCZ	140		x 140L
-100DCZ	165		x 165L
CDQ2BS100-10DCZ	15.5		85
-15DCZ		90	x 90L
-20DCZ		95	x 95L
-25DCZ		100	x 100L
-30DCZ		105	x 105L
-35DCZ		110	x 110L
-40DCZ		115	x 115L
-45DCZ		120	x 120L
-50DCZ		125	x 125L
-75DCZ		150	x 150L
-100DCZ		175	x 175L

- Standard
- Single Acting
- Double Rod
- Axial Piping
- Water Resistant
- High Lateral Load
- End Lock
- Clean Series
- Copper/Fluorine free series
- Construction and Parts
- Warranty and Operating Instructions
- Mounting and Auto Switches
- Made to Order

Series **CBQ2** with End Lock Mounting Bolt

Mounting Bolt for CBQ2

Mounting method: Mounting bolt for through-hole mounting of the CBQ2 is available as an option. Refer to the following for ordering procedures. Order the actual number of bolts that will be used.

Example) CQ-M5x75L 4 pcs.

Note) Be sure to use the attached flat washers when mounting $\phi 20$ and $\phi 25$ cylinders with through-holes.

Material: Chromium molybdenum steel
Surface treatment: Nickel plated

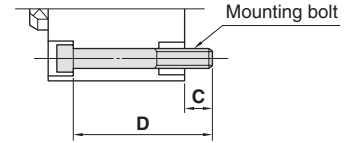

With Head End Lock (H□)

Cylinder model	D	Mounting bolt part no.
C□BQ2B20-10DC-H□	75	CQ-M5 x 75L
-15DC-H□	80	x 80L
-20DC-H□	85	x 85L
-25DC-H□	90	x 90L
-50DC-H□	120	x 120L
-75DC-H□	145	x 145L
-100DC-H□	170	x 170L
C□BQ2B25-10DC-H□	75	CQ-M5 x 75L
-15DC-H□	80	x 80L
-20DC-H□	85	x 85L
-25DC-H□	90	x 90L
-50DC-H□	120	x 120L
-75DC-H□	145	x 145L
-100DC-H□	170	x 170L
C□BQ2B32-10DC-H□	75	CQ-M5 x 75L
-15DC-H□	80	x 80L
-20DC-H□	85	x 85L
-25DC-H□	90	x 90L
-50DC-H□	115	x 115L
-75DC-H□	140	x 140L
-100DC-H□	165	x 165L

Cylinder model	C	D	Mounting bolt part no.
C□BQ2B40-10DC-H□	7	85	CQ-M5 x 85L
-15DC-H□		90	x 90L
-20DC-H□		95	x 95L
-25DC-H□		100	x 100L
-50DC-H□		125	x 125L
-75DC-H□		150	x 150L
-100DC-H□		175	x 175L
C□BQ2B50-10DC-H□	12.5	90	CQ-M6 x 90L
-15DC-H□		95	x 95L
-20DC-H□		100	x 100L
-25DC-H□		105	x 105L
-50DC-H□		130	x 130L
-75DC-H□		155	x 155L
C□BQ2B63-10DC-H□	13.5	90	CQ-M8 x 90L
-15DC-H□		95	x 95L
-20DC-H□		100	x 100L
-25DC-H□		105	x 105L
-50DC-H□		130	x 130L
C□BQ2B80-25DC-H□	12.5	135	CQ-M10 x 135L
-50DC-H□		160	x 160L
C□BQ2B100-25DC-H□	13	145	CQ-M10 x 145L
-50DC-H□		170	x 170L

With Rod End Lock (R□)

Cylinder model	C	D	Mounting bolt part no.	
C□BQ2B20-10DC-R□	6.5	65	CQ-M5 x 65L	
-15DC-R□		70	x 70L	
-20DC-R□		75	x 75L	
-25DC-R□		80	x 80L	
C□BQ2B25-10DC-R□	10	120	x 120L	
-50DC-R□		145	x 145L	
-75DC-R□		170	x 170L	
-100DC-R□		170	x 170L	
C□BQ2B32-10DC-R□		8.5	70	CQ-M5 x 70L
-15DC-R□	75		x 75L	
-20DC-R□	80		x 80L	
-25DC-R□	85		x 85L	
-50DC-R□	120		x 120L	
-75DC-R□	145		x 145L	
C□BQ2B32-10DC-R□	7	170	x 170L	
-100DC-R□		170	x 170L	
C□BQ2B32-10DC-R□		9	70	CQ-M5 x 70L
-15DC-R□			75	x 75L
-20DC-R□			80	x 80L
-25DC-R□	85		x 85L	
-50DC-R□	110		x 110L	
-75DC-R□	135		x 135L	
C□BQ2B32-10DC-R□	9	160	x 160L	
-100DC-R□		160	x 160L	

Cylinder model	C	D	Mounting bolt part no.	
C□BQ2B40-10DC-R□	7.5	75	CQ-M5 x 75L	
-15DC-R□		80	x 80L	
-20DC-R□		85	x 85L	
-25DC-R□		90	x 90L	
-50DC-R□		115	x 115L	
-75DC-R□		140	x 140L	
-100DC-R□		165	x 165L	
C□BQ2B50-10DC-R□	12.5	80	CQ-M6 x 80L	
-15DC-R□		85	x 85L	
-20DC-R□		90	x 90L	
-25DC-R□		95	x 95L	
-50DC-R□		120	x 120L	
-75DC-R□		145	x 145L	
C□BQ2B63-10DC-R□	14.5	170	x 170L	
-100DC-R□		170	x 170L	
C□BQ2B63-10DC-R□		14.5	85	CQ-M8 x 85L
-15DC-R□			90	x 90L
-20DC-R□			95	x 95L
-25DC-R□	100		x 100L	
-50DC-R□	125		x 125L	
-75DC-R□	150		x 150L	
C□BQ2B80-25DC-R□	15	175	x 175L	
-100DC-R□		175	x 175L	
C□BQ2B80-25DC-R□	15	130	CQ-M10 x 130L	
-50DC-R□		155	x 155L	
C□BQ2B100-25DC-R□	15.5	140	CQ-M10 x 140L	
-50DC-R□		165	x 165L	

Mounting Bolt for CQ2B/Without Auto Switch

Mounting method: Mounting bolt for through-hole mounting of the CQ2B is available as an option. Refer to the following for ordering procedures. Order the actual number of bolts that will be used.

Material: Chromium molybdenum steel
 Surface treatment: Nickel plated

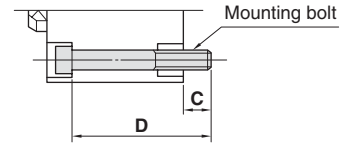

Example) CQ-M5x35L 2 pcs.

Cylinder model	C	D	Mounting bolt part no.
CQ2B20^R-5D	7.5	35	CQ-M5 x 35L
-10D		40	x 40L
-15D		45	x 45L
-20D		50	x 50L
-25D		55	x 55L
-30D		60	x 60L
-35D		65	x 65L
-40D		70	x 70L
-45D		75	x 75L
-50D		80	x 80L
CQ2B25^R-5D	9.5	40	CQ-M5 x 40L
-10D		45	x 45L
-15D		50	x 50L
-20D		55	x 55L
-25D		60	x 60L
-30D		65	x 65L
-35D		70	x 70L
-40D		75	x 75L
-45D		80	x 80L
-50D		85	x 85L
CQ2B32^R-5DZ	9	40	CQ-M5 x 40L
-10DZ		45	x 45L
-15DZ		50	x 50L
-20DZ		55	x 55L
-25DZ		60	x 60L
-30DZ		65	x 65L
-35DZ		70	x 70L
-40DZ		75	x 75L
-45DZ		80	x 80L
-50DZ		85	x 85L
-75DZ	120	x 120L	
-100DZ	145	x 145L	

Cylinder model	C	D	Mounting bolt part no.
CQ2B40^R-5DZ	7.5	35	CQ-M5 x 35L
-10DZ		40	x 40L
-15DZ		45	x 45L
-20DZ		50	x 50L
-25DZ		55	x 55L
-30DZ		60	x 60L
-35DZ		65	x 65L
-40DZ		70	x 70L
-45DZ		75	x 75L
-50DZ		80	x 80L
-75DZ	115	x 115L	
-100DZ	140	x 140L	
CQ2B50^R-10DZ	12.5	45	CQ-M6 x 45L
-15DZ		50	x 50L
-20DZ		55	x 55L
-25DZ		60	x 60L
-30DZ		65	x 65L
-35DZ		70	x 70L
-40DZ		75	x 75L
-45DZ		80	x 80L
-50DZ		85	x 85L
-75DZ		120	x 120L
-100DZ	145	x 145L	
CQ2B63^R-10DZ	14.5	50	CQ-M8 x 50L
-15DZ		55	x 55L
-20DZ		60	x 60L
-25DZ		65	x 65L
-30DZ		70	x 70L
-35DZ		75	x 75L
-40DZ		80	x 80L
-45DZ		85	x 85L
-50DZ		90	x 90L
-75DZ		125	x 125L
-100DZ	150	x 150L	

Cylinder model	C	D	Mounting bolt part no.
CQ2B80^R-10DZ	15	55	CQ-M10 x 55L
-15DZ		60	x 60L
-20DZ		65	x 65L
-25DZ		70	x 70L
-30DZ		75	x 75L
-35DZ		80	x 80L
-40DZ		85	x 85L
-45DZ		90	x 90L
-50DZ		95	x 95L
-75DZ		130	x 130L
-100DZ	155	x 155L	
CQ2B100^R-10DZ	15.5	65	CQ-M10 x 65L
-15DZ		70	x 70L
-20DZ		75	x 75L
-25DZ		80	x 80L
-30DZ		85	x 85L
-35DZ		90	x 90L
-40DZ		95	x 95L
-45DZ		100	x 100L
-50DZ		105	x 105L
-75DZ		140	x 140L
-100DZ	165	x 165L	

- Standard
- Single Acting
- Double Rod
- Axial Piping
- Water Resistant
- High Lateral Load
- End Lock
- Clean Series
- Copper/Fluorine free series
- Construction and Parts
- Warranty and Operating Instructions
- Mounting and Auto Switches
- Made to Order

Series CQ2^R_V Water Resistant with Auto Switch

Mounting Bolt

Mounting Bolt for CDQ2B/With Auto Switch

Mounting method: Mounting bolt for through-hole mounting of the CDQ2B is available as an option. Refer to the following for ordering procedures. Order the actual number of bolts that will be used.

Example) CQ-M5x50L 2 pcs.

Material: Chromium molybdenum steel
Surface treatment: Nickel plated

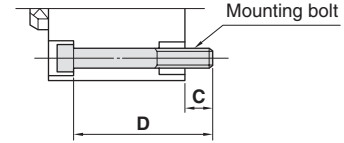

Cylinder model	C	D	Mounting bolt part no.
CDQ2B20^R-5DZ	10.5	50	CQ-M5 x 50L
-10DZ		55	x 55L
-15DZ		60	x 60L
-20DZ		65	x 65L
-25DZ		70	x 70L
-30DZ		75	x 75L
-35DZ		80	x 80L
-40DZ		85	x 85L
-45DZ		90	x 90L
-50DZ		95	x 95L
CDQ2B25^R-5DZ	9.5	50	CQ-M5 x 50L
-10DZ		55	x 55L
-15DZ		60	x 60L
-20DZ		65	x 65L
-25DZ		70	x 70L
-30DZ		75	x 75L
-35DZ		80	x 80L
-40DZ		85	x 85L
-45DZ		90	x 90L
-50DZ		95	x 95L
CDQ2B32^R-5DZ	9	50	CQ-M5 x 50L
-10DZ		55	x 55L
-15DZ		60	x 60L
-20DZ		65	x 65L
-25DZ		70	x 70L
-30DZ		75	x 75L
-35DZ		80	x 80L
-40DZ		85	x 85L
-45DZ		90	x 90L
-50DZ		95	x 95L
-75DZ	120	x 120L	
-100DZ	145	x 145L	

Cylinder model	C	D	Mounting bolt part no.
CDQ2B40^R-5DZ	7.5	45	CQ-M5 x 45L
-10DZ		50	x 50L
-15DZ		55	x 55L
-20DZ		60	x 60L
-25DZ		65	x 65L
-30DZ		70	x 70L
-35DZ		75	x 75L
-40DZ		80	x 80L
-45DZ		85	x 85L
-50DZ		90	x 90L
-75DZ	115	x 115L	
-100DZ	140	x 140L	
CDQ2B50^R-10DZ	12.5	55	CQ-M6 x 55L
-15DZ		60	x 60L
-20DZ		65	x 65L
-25DZ		70	x 70L
-30DZ		75	x 75L
-35DZ		80	x 80L
-40DZ		85	x 85L
-45DZ		90	x 90L
-50DZ		95	x 95L
-75DZ		120	x 120L
-100DZ	145	x 145L	
CDQ2B63^R-10DZ	14.5	60	CQ-M8 x 60L
-15DZ		65	x 65L
-20DZ		70	x 70L
-25DZ		75	x 75L
-30DZ		80	x 80L
-35DZ		85	x 85L
-40DZ		90	x 90L
-45DZ		95	x 95L
-50DZ		100	x 100L
-75DZ		125	x 125L
-100DZ	150	x 150L	

Cylinder model	C	D	Mounting bolt part no.
CDQ2B80^R-10DZ	15	65	CQ-M10 x 65L
-15DZ		70	x 70L
-20DZ		75	x 75L
-25DZ		80	x 80L
-30DZ		85	x 85L
-35DZ		90	x 90L
-40DZ		95	x 95L
-45DZ		100	x 100L
-50DZ		105	x 105L
-75DZ		130	x 130L
-100DZ	155	x 155L	
CDQ2B100^R-10DZ	15.5	75	CQ-M10 x 75L
-15DZ		80	x 80L
-20DZ		85	x 85L
-25DZ		90	x 90L
-30DZ		95	x 95L
-35DZ		100	x 100L
-40DZ		105	x 105L
-45DZ		110	x 110L
-50DZ		115	x 115L
-75DZ		140	x 140L
-100DZ	165	x 165L	

Mounting Brackets/Part Numbers

Standard Cylinders, Non-Rotating Rod, and High Lateral Load

Bore size (mm)	Model	Foot ^{Note 1)}	Flange	Double clevis
12	Without switch	CQ2□□-□D	CQ-L012	CQ-F012 CQ-D012
	With switch	CQ2□□-□DZ	CQ-LZ12	
16	Without switch	CQ2□□-□D	CQ-L016	CQ-F016 CQ-D016
	With switch	CQ2□□-□DZ	CQ-LZ16	
20	Without switch	CQ2□□-□D	CQ-L020	CQ-F020 CQ-D020
	With switch	CQ2□□-□DZ	CQ-LZ20	
25	Without switch	CQ2□□-□D	CQ-L025	CQ-F025 CQ-D025
	With switch	CQ2□□-□DZ	CQ-LZ25	
32	CQ2□□-□DZ	CQ-L032	CQ-F032	CQ-D032
40	CQ2□□-□DZ	CQ-L040	CQ-F040	CQ-D040
50	CQ2□□-□DZ	CQ-L050	CQ-F050	CQ-D050
63	CQ2□□-□DZ	CQ-L063	CQ-F063	CQ-D063
80	CQ2□□-□DZ	CQ-L080	CQ-F080	CQ-D080
100	CQ2□□-□DZ	CQ-L100	CQ-F100	CQ-D100

Note 1) When ordering a foot bracket, the required quantity will be different depending on the bore size.
 ø12 to ø25:
 • Without switch: Order 2 pieces per cylinder.
 • With switch: Order 1 piece per cylinder. (Part number for a set of 2 foot brackets)
 ø32 to ø100:
 • Order 2 pieces per cylinder.

Note 2) Parts belonging to each bracket are as follows.
 Foot or Flange: Body mounting bolts
 Double clevis: Clevis pin, Type C retaining rings for axis, Body mounting bolts

Long Stroke

When ordering a foot bracket for strokes greater than 100mm, order 2 pieces per cylinder.

Non-Rotating Rod (Single or Double Rod)

When ordering a foot bracket, order 2 pieces per cylinder.
 Double Clevis mounting bracket is not applicable to Double Rod Cylinders.

High Lateral Load

When ordering a foot bracket, order 2 pieces per cylinder.

With End Lock

Bore size (mm)	Foot ^{Note 1)}	Flange	Double clevis ^{Note 2)}
20	CQS-L020	CQS-F020	CQS-D020
25	CQS-L025	CQS-F025	CQS-D025
32	CQ-L032	CQ-F032	CQ-D032
40	CQ-L040	CQ-F040	CQ-D040
50	CQ-L050	CQ-F050	CQ-D050
63	CQ-L063	CQ-F063	CQ-D063
80	CQ-L080	CQ-F080	CQ-D080
100	CQ-L100	CQ-F100	CQ-D100

Note 1) When ordering a foot bracket, order 2 pieces per cylinder.
 Note 2) Parts belonging to each bracket are as follows.
 Foot or Flange: Body mounting bolts
 Double clevis: Clevis pin, Type C retaining rings for axis, Body mounting bolts
 Note 3) Clevis pin and retaining rings are included with double clevis.



Accessory Brackets

Single Knuckle Joint

I-G012, I-Z015A
I-G02, I-G03

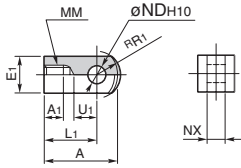

Material: Carbon steel
Surface treatment: Nickel plated

I-G04, I-G05
I-G08, I-G10

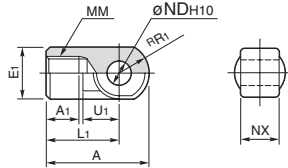

Material: Cast iron
Surface treatment: Nickel plated

(mm)

Part no.	Applicable bore size (mm)	A	A ₁	E ₁	L ₁	MM	RFR ₁	U ₁	ND _{H10}	NX
I-G012	12	21.5	6	□10	16	M5 x 0.8	6.3	7	5 ^{+0.048} ₀	5 ^{-0.2} _{-0.4}
I-Z015A	16	32	8	□12	25	M6 x 1	8.1	14	5 ^{+0.048} ₀	6.4 ^{-0.1} _{-0.3}
I-G02	20	34	8.5	□16	25	M8 x 1.25	10.3	11.5	8 ^{+0.058} ₀	8 ^{-0.2} _{-0.4}
I-G03	25	41	10.5	□20	30	M10 x 1.25	12.8	14	10 ^{+0.058} ₀	10 ^{-0.2} _{-0.4}
I-G04	32,40	42	14	ø22	30	M14 x 1.5	12	14	10 ^{+0.058} ₀	18 ^{-0.3} _{-0.5}
I-G05	50,63	56	18	ø28	40	M18 x 1.5	16	20	14 ^{+0.070} ₀	22 ^{-0.3} _{-0.5}
I-G08	80	71	21	ø38	50	M22 x 1.5	21	27	18 ^{+0.070} ₀	28 ^{-0.3} _{-0.5}
I-G10	100	79	21	ø44	55	M26 x 1.5	24	31	22 ^{+0.084} ₀	32 ^{-0.3} _{-0.5}

Double Knuckle Joint

Y-G012, Y-Z015A
Y-G02, Y-G03

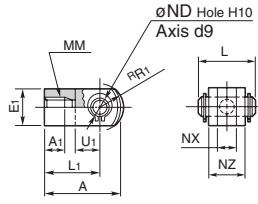

Material: Carbon steel
Surface treatment: Nickel plated

Y-G04, Y-G05
Y-G08, Y-G10

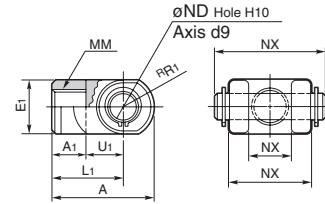

Material: Cast iron
Surface treatment: Nickel plated

(mm)

Part no.	Applicable bore size (mm)	A	A ₁	E ₁	L ₁	MM	RFR ₁	U ₁	ND _{H10}	NX	NZ	L	Applicable pin part no.
Y-G012	12	21.5	6	□10	16	M5 x 0.8	6.3	7	5 ^{+0.048} ₀	5 ^{+0.4} _{+0.2}	10	14.6	IY-G012
Y-Z015A	16	28	11	□12	21	M6 x 1	8.1	10	5 ^{+0.048} ₀	6.5 ^{+0.2} ₊₀	12	16.6	IY-J015
Y-G02	20	34	8.5	□16	25	M8 x 1.25	10.3	11.5	8 ^{+0.058} ₀	8 ^{+0.4} _{+0.2}	16	21	IY-G02
Y-G03	25	41	10.5	□20	30	M10 x 1.25	12.8	14	10 ^{+0.058} ₀	10 ^{+0.4} _{+0.2}	20	25.6	IY-G03
Y-G04	32,40	42	16	ø22	30	M14 x 1.5	12	14	10 ^{+0.058} ₀	18 ^{+0.5} _{+0.3}	36	41.6	IY-G04
Y-G05	50,63	56	20	ø28	40	M18 x 1.5	16	20	14 ^{+0.070} ₀	22 ^{+0.5} _{+0.3}	44	50.6	IY-G05
Y-G08	80	71	23	ø38	50	M22 x 1.5	21	27	18 ^{+0.070} ₀	28 ^{+0.5} _{+0.3}	56	64	IY-G08
Y-G10	100	79	24	ø44	55	M26 x 1.5	24	31	22 ^{+0.084} ₀	32 ^{+0.5} _{+0.3}	64	72	IY-G10

* Knuckle pin and retaining rings are included.

Knuckle Pin (Common with double clevis pin)

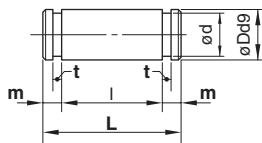

Material: Carbon steel
(mm)

Part no.	Applicable bore size (mm)	Dd9	L	d	l	m	t	Applicable retaining ring
IY-G012	12	5 ^{-0.030} _{-0.060}	14.6	4.8	10.2	1.5	0.7	Type C5 for axis
IY-J015	16	5 ^{-0.030} _{-0.060}	16.6	4.8	12.2	1.5	0.7	Type C5 for axis
IY-G02	20	8 ^{-0.040} _{-0.076}	21	7.6	16.2	1.5	0.9	Type C8 for axis
IY-G03	25	10 ^{-0.040} _{-0.076}	25.6	9.6	20.2	1.55	1.15	Type C10 for axis
IY-G04	32,40	10 ^{-0.040} _{-0.076}	41.6	9.6	36.2	1.55	1.15	Type C10 for axis
IY-G05	50,63	14 ^{-0.050} _{-0.093}	50.6	13.4	44.2	2.05	1.15	Type C14 for axis
IY-G08	80	18 ^{-0.050} _{-0.093}	64	17	56.2	2.55	1.35	Type C18 for axis
IY-G10	100	22 ^{-0.065} _{-0.117}	72	21	64.2	2.55	1.35	Type C22 for axis

* Type C retaining rings for axis are included.

Rod End Nut

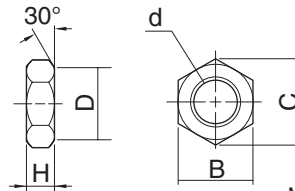

Material: Carbon steel
Surface treatment: Nickel plated

CQ2 Rod End Nut

Part no.	Applicable bore size (mm)	d	H	B	C
NTJ-015A	12	M5 x 0.8	4	8	9.2
NT-015A	16	M6 x 1	5	10	11.5
NT-02	20	M8 x 1.25	5	13	15.0
NT-03	25	M10 x 1.25	6	17	19.6
NT-04	32, 40	M14 x 1.5	8	22	25.4
NT-05	50, 63	M18 x 1.5	11	27	31.2
NT-08	80	M22 x 1.5	13	32	37.0
NT-10	100	M26 x 1.5	16	41	47.3

NCQ2 Rod End Nut

Part no.	Applicable bore size (mm)	d	H	B	C
JM-01	12, 16	#8-32UNC	3.3	8.7	10
JM-02	20	#10-32UNF	3.3	9.5	11
JM-025	25	1/4-28UNF	4.1	11.2	13
JM-03	32	5/16-24UNF	4.8	12.7	14.7
JM-04	40	3/8-24UNF	5.6	14.3	16.5
JM-05	50, 63	1/2-20UNF	7.9	19.1	22
JM-08	80	5/8-18UNF	9.7	23.8	27.4
JM-10	100	3/4-16UNF	10.7	28.7	33

Note) Rod end nut included when option "M" is ordered.

Simple Joint (CQ2): $\phi 32$ to $\phi 100$



Joint/Mounting Bracket (Type A/B)/Part No.

YA - 03

• Applicable air cylinder bore size

03	For $\phi 32, \phi 40$
05	For $\phi 50, \phi 63$
08	For $\phi 80$
10	For $\phi 100$

• Mounting bracket

YA	Type A mounting bracket
YB	Type B mounting bracket
YU	Joint

Allowable Eccentricity (mm)

Bore size (mm)	32	40	50	63	80	100
Eccentricity tolerance	± 1				± 1.5	± 2
Backlash	0.5					

<Ordering>

- Joints are not included with type A or B mounting brackets. Order them separately.

(Example)

Bore size $\phi 40$ Part no.

- Type A mounting bracket YA-03
- Joint YU-03

Joint/Mounting Bracket (Type A/B)/Part No.

Bore size (mm)	Joint	Applicable mounting bracket	
		Type A mounting bracket	Type B mounting bracket
32, 40	YU-03	YA-03	YB-03
50, 63	YU-05	YA-05	YB-05
80	YU-08	YA-08	YB-08
100	YU-10	YA-10	YB-10

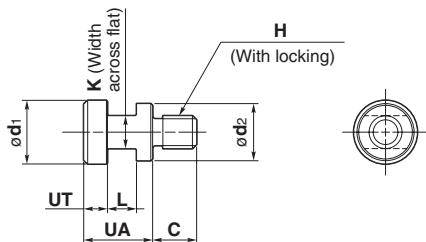

Material: Chromium molybdenum steel (Nickel plated) (mm)

Part no.	Applicable bore size (mm)	UA	C	d ₁	d ₂	H	K	L	UT	Weight (g)
YU-03	32, 40	17	11	15.8	14	M8 x 1.25	8	7	6	25
YU-05	50, 63	17	13	19.8	18	M10 x 1.5	10	7	6	40
YU-08	80	22	20	24.8	23	M16 x 2	13	9	8	90
YU-10	100	26	26	29.8	28	M20 x 2.5	14	11	10	160

Type A Mounting Bracket

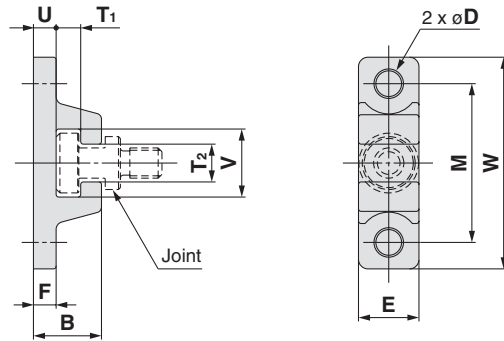

Material: Chromium molybdenum steel (Nickel plated) (mm)

Part no.	Bore size (mm)	B	D	E	F	M	T ₁	T ₂
YA-03	32, 40	18	6.8	16	6	42	6.5	10
YA-05	50, 63	20	9	20	8	50	6.5	12
YA-08	80	26	11	25	10	62	8.5	16
YA-10	100	31	14	30	12	76	10.5	18

Part no.	Bore size (mm)	U	V	W	Weight (g)
YA-03	32, 40	6	18	56	55
YA-05	50, 63	8	22	67	100
YA-08	80	10	28	83	195
YA-10	100	12	36	100	340

Type B Mounting Bracket

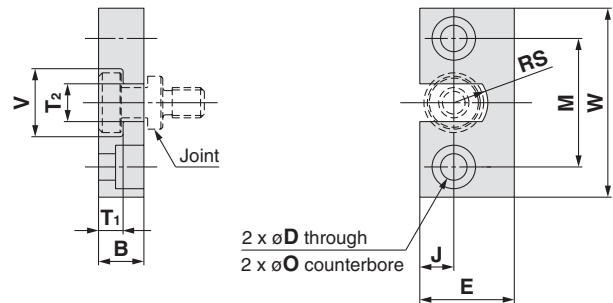

Material: Stainless steel (mm)

Part no.	Bore size (mm)	B	D	E	J	M	ϕO
YB-03	32, 40	12	7	25	9	34	11.5 depth 7.5
YB-05	50, 63	12	9	32	11	42	14.5 depth 8.5
YB-08	80	16	11	38	13	52	18 depth 12
YB-10	100	19	14	50	17	62	21 depth 14

Part no.	Bore size (mm)	T ₁	T ₂	V	W	RS	Weight (g)
YB-03	32, 40	6.5	10	18	50	9	80
YB-05	50, 63	6.5	12	22	60	11	120
YB-08	80	8.5	16	28	75	14	230
YB-10	100	10.5	18	36	90	18	455

- Standard
- Single Acting
- Double Rod
- Axial Piping
- Water Resistant
- High Lateral Load
- End Lock
- Clean Series
- Copper/Fluorine free series
- Construction and Parts
- Warranty and Operating Instructions
- Mounting and Auto Switches
- Made to Order

Auto Switches

Applicable Auto Switches	
Standard	182
Long stroke	
Large bore	183
Large bore, double rod	
Non-rotating rod	184
Single acting	
Double rod	185
Double rod, non-rotating rod	
High lateral load	186
Water resistant	
Axial piping	195
End lock	201
Auto Switch Common Specifications	207
Auto Switch Connection	209
Switch Specifications by Model	
D-M9N(V) / D-M9P(V) / D-M9B(V)	210
D-M9NW(V) / D-M9PW(V) / D-M9BW(V)	211
D-M9NA(V) / D-M9PA(V) / D-M9BA(V)	212
D-M90(V) / D-A93(V) / D-A96(V)	213
D-P3DWSC / D-P3DWSW	214
D-P3DW / L / Z	215

- Standard
- Single Acting
- Double Rod
- Axial Piping
- Water Resistant
- High Lateral Load
- End Lock
- Clean Series
- Copper/Fluorine free series
- Construction and Parts
- Warranty and Operating Instructions
- Mounting and Auto Switches**
- Made to Order

Applicable Auto Switches

Standard

Type	Special function	Electrical entry	Indicator light	Wiring (Output)	Load voltage		Auto switch model		Lead wire length (m)					Pre-wired connector	Applicable load					
					DC	AC	Perpendicular	In-line	0.5 (Nil)	1 (M)	3 (L)	5 (Z)	None (N)		IC circuit	Relay, PLC				
Solid state auto switch	—	Grommet	Yes	3-wire (NPN)	24 V	5 V, 12 V	—	M9NV	M9N	●	●	●	○	—	○	IC circuit	Relay, PLC			
				3-wire (PNP)				M9PV	M9P	●	●	●	○	—	○					
				2-wire				M9BV	M9B	●	●	●	○	—	○					
	Diagnostic indication (2-color indication)			3-wire (NPN)	24 V	5 V, 12 V	—	M9NWV	M9NW	●	●	●	○	—	○	IC circuit				
				3-wire (PNP)				M9PWV	M9PW	●	●	●	○	—	○					
	Water resistant (2-color indication)			2-wire	24 V	12 V	—	M9BWV	M9BW	●	●	●	○	—	○	—				
				3-wire (NPN)				M9NAV**	M9NA**	○	○	●	○	—	○					
	Magnetic field resistant (2-color indication)			3-wire (PNP)	24 V	12 V	—	M9PAV**	M9PA**	○	○	●	○	—	○	IC circuit				
				2-wire				M9BAV**	M9BA**	○	○	●	○	—	○					
				2-wire (Non-polar)				—	P3DW	●	—	●	●	—	○			—		
Reed auto switch	—	Grommet	Yes	3-wire (NPN equivalent)	24 V	5 V, 12 V, 100 V or less	—	A96V	A96	●	—	●	—	—	IC circuit	—				
				No				2-wire	12 V	100 V	A93V	A93	●	—			●		—	—
									5 V, 12 V	100 V or less	A90V	A90	●	—			●	—	—	IC circuit

- ** Water resistant type auto switches can be mounted on the above models, but in such case SMC cannot guarantee water resistance. If water resistance is needed, we recommend water resistant cylinders be used. (Page 91)
- * Lead wire length symbols: 0.5 m Nil (Example) M9NW
1 m M (Example) M9NWM
3 m L (Example) M9NWL
5 m Z (Example) M9NWZ
- * Solid state auto switches marked with "○" are produced upon receipt of order.
- * The D-P3DW□ type is available from ø32 to ø100 only.
- * There are other applicable auto switches other than the listed above. For details, refer to page 194.
- * For details about auto switches with pre-wired connector, refer to pages 1328 and 1329 in Best Pneumatics No. 2.

Built-in Magnet Cylinder Model

If a built-in magnet cylinder without an auto switch is required, there is no need to enter the symbol for the auto switch.
(Example) CDQ2L40-200DCZ

Long Stroke

Type	Special function	Electrical entry	Indicator light	Wiring (Output)	Load voltage		Auto switch model		Lead wire length (m)					Pre-wired connector	Applicable load					
					DC	AC	Perpendicular	In-line	0.5 (Nil)	1 (M)	3 (L)	5 (Z)	None (N)		IC circuit	Relay, PLC				
Solid state auto switch	—	Grommet	Yes	3-wire (NPN)	24 V	5 V, 12 V	—	M9NV	M9N	●	●	●	○	—	○	IC circuit	Relay, PLC			
				3-wire (PNP)				M9PV	M9P	●	●	●	○	—	○					
				2-wire				M9BV	M9B	●	●	●	○	—	○					
	Diagnostic indication (2-color indication)			3-wire (NPN)	24 V	5 V, 12 V	—	M9NWV	M9NW	●	●	●	○	—	○	IC circuit				
				3-wire (PNP)				M9PWV	M9PW	●	●	●	○	—	○					
	Water resistant (2-color indication)			2-wire	24 V	12 V	—	M9BWV	M9BW	●	●	●	○	—	○	—				
				3-wire (NPN)				M9NAV**	M9NA**	○	○	●	○	—	○					
	Magnetic field resistant (2-color indication)			3-wire (PNP)	24 V	12 V	—	M9PAV**	M9PA**	○	○	●	○	—	○	IC circuit				
				2-wire				M9BAV**	M9BA**	○	○	●	○	—	○					
				2-wire (Non-polar)				—	P3DW	●	—	●	●	—	○			—		
Reed auto switch	—	Grommet	Yes	3-wire (NPN equivalent)	24 V	5 V, 12 V, 100 V or less	—	A96V	A96	●	—	●	—	—	IC circuit	—				
				No				2-wire	12 V	100 V	A93V	A93	●	—			●		—	—
									5 V, 12 V	100 V or less	A90V	A90	●	—			●	—	—	IC circuit

- ** Water resistant type auto switches can be mounted on the above models, but in such case SMC cannot guarantee water resistance. Consult with SMC regarding water resistant types with the above model numbers.
- * Lead wire length symbols: 0.5 m Nil (Example) M9NW
1 m M (Example) M9NWM
3 m L (Example) M9NWL
5 m Z (Example) M9NWZ
- * There are other applicable auto switches other than the listed above. For details, refer to page 194.
- * For details about auto switches with pre-wired connector, refer to pages 1328 and 1329 in Best Pneumatics No. 2.
- * Solid state auto switches marked with "○" are produced upon receipt of order.

Refer to pages 1263 to 1371 in Best Pneumatics No. 2 for further information on auto switches.
Refer to the individual catalog (ES20-201) for the D-P3DW type.

Applicable Auto Switches

Large Bore

Type	Special function	Electrical entry	Indicator light	Wiring (Output)	Load voltage		Auto switch model		Lead wire length (m)					Pre-wired connector	Applicable load				
					DC	AC	Perpendicular	In-line	0.5 (Nil)	1 (M)	3 (L)	5 (Z)	None (N)		IC circuit	Relay, PLC			
Solid state auto switch	—	Grommet	Yes	3-wire (NPN)	24 V	5 V, 12 V	—	M9NV	M9N	●	●	●	○	—	○	IC circuit	Relay, PLC		
				3-wire (PNP)				M9PV	M9P	●	●	●	○	—	○				
				2-wire				M9BV	M9B	●	●	●	○	—	○				
	Diagnostic indication (2-color indication)			3-wire (NPN)	M9NVV	M9NV	●	●	●	○	—	○	IC circuit						
				3-wire (PNP)	M9PVV	M9PV	●	●	●	○	—	○							
				2-wire	M9BVV	M9BV	●	●	●	○	—	○							
	Water resistant (2-color indication)			3-wire (NPN)	M9NAV**	M9NA**	○	○	●	○	—	○	IC circuit						
				3-wire (PNP)	M9PAV**	M9PA**	○	○	●	○	—	○							
				2-wire	M9BAV**	M9BA**	○	○	●	○	—	○							
Reed auto switch	—	Grommet	Yes	3-wire (NPN equivalent)	24 V	5 V	—	A96V	A96	●	—	●	—	—	IC circuit	—			
				2-wire				12 V	100 V	A93V	A93	●	—	●			—	—	Relay, PLC
								5 V, 12 V	100 V or less	A90V	A90	●	—	●			—	—	

* * Water resistant type auto switches can be mounted on the above models, but in such case SMC cannot guarantee water resistance. Consult with SMC regarding water resistant types with the above model numbers.
 * Lead wire length symbols: 0.5 m Nil (Example) M9NW
 1 m M (Example) M9NWM
 3 m L (Example) M9NWL
 5 m Z (Example) M9NWZ
 * Solid state auto switches marked with "○" are produced upon receipt of order.

* There are other applicable auto switches other than the listed above. For details, refer to page 194.
 * For details about auto switches with pre-wired connector, refer to pages 1328 and 1329 in Best Pneumatics No. 2.

Double Rod, Large Bore

Type	Special function	Electrical entry	Indicator light	Wiring (Output)	Load voltage		Auto switch model		Lead wire length (m)					Pre-wired connector	Applicable load				
					DC	AC	Perpendicular	In-line	0.5 (Nil)	1 (M)	3 (L)	5 (Z)	None (N)		IC circuit	Relay, PLC			
Solid state auto switch	—	Grommet	Yes	3-wire (NPN)	24 V	5 V, 12 V	—	M9NV	M9N	●	●	●	○	—	○	IC circuit	Relay, PLC		
				3-wire (PNP)				M9PV	M9P	●	●	●	○	—	○				
				2-wire				M9BV	M9B	●	●	●	○	—	○				
	Diagnostic indication (2-color indication)			3-wire (NPN)	M9NVV	M9NV	●	●	●	○	—	○	IC circuit						
				3-wire (PNP)	M9PVV	M9PV	●	●	●	○	—	○							
				2-wire	M9BVV	M9BV	●	●	●	○	—	○							
	Water resistant (2-color indication)			3-wire (NPN)	M9NAV**	M9NA**	○	○	●	○	—	○	IC circuit						
				3-wire (PNP)	M9PAV**	M9PA**	○	○	●	○	—	○							
				2-wire	M9BAV**	M9BA**	○	○	●	○	—	○							
Reed auto switch	—	Grommet	Yes	3-wire (NPN equivalent)	24 V	5 V	—	A96V	A96	●	—	●	—	—	IC circuit	—			
				2-wire				12 V	100 V	A93V	A93	●	—	●			—	—	Relay, PLC
								5 V, 12 V	100 V or less	A90V	A90	●	—	●			—	—	

* * Water resistant type auto switches can be mounted on the above models, but in such case SMC cannot guarantee water resistance. Consult with SMC regarding water resistant types with the above model numbers.
 * Lead wire length symbols: 0.5 m Nil (Example) M9NW
 1 m M (Example) M9NWM
 3 m L (Example) M9NWL
 5 m Z (Example) M9NWZ
 * Solid state auto switches marked with "○" are produced upon receipt of order.

* There are other applicable auto switches other than the listed above. For details, refer to page 194.
 * For details about auto switches with pre-wired connector, refer to pages 1328 and 1329 in Best Pneumatics No. 2.

Standard
Single Acting
Double Rod
Axial Piping
Water Resistant
High Lateral Load
End Lock
Clean Series
Copper/Fluorine free series
Construction and Parts
Warranty and Operating Instructions
Mounting and Auto Switches
Made to Order

Applicable Auto Switches

Non-Rotating Rod

Type	Special function	Electrical entry	Indicator light	Wiring (Output)	Load voltage		Auto switch model		Lead wire length (m)					Pre-wired connector	Applicable load			
					DC	AC	Perpendicular	In-line	0.5 (Nil)	1 (M)	3 (L)	5 (Z)	None (N)		IC circuit	Relay, PLC		
Solid state auto switch	—	Grommet	Yes	3-wire (NPN)	24 V	5 V, 12 V	—	M9NV	M9N	●	●	●	○	—	○	IC circuit	Relay, PLC	
				3-wire (PNP)				M9PV	M9P	●	●	●	○	—	○			
	2-wire			M9BV				M9B	●	●	●	○	—	○	—	—		
	3-wire (NPN)			M9NWW				M9NW	●	●	●	○	—	○	IC circuit			
	3-wire (PNP)			M9PWV				M9PW	●	●	●	○	—	○				
	2-wire			M9BWW				M9BW	●	●	●	○	—	○	—			
	3-wire (NPN)			M9NAV**				M9NA**	○	○	●	○	—	○	IC circuit			
	3-wire (PNP)			M9PAV**				M9PA**	○	○	●	○	—	○				
	2-wire			M9BAV**				M9BA**	○	○	●	○	—	○	—			
	Magnetic field resistant (2-color indication)			2-wire (Non-polar)				—	—	—	P3DW	●	—	●	●	—		○
Reed auto switch	—	Grommet	Yes	3-wire (NPN equivalent)	24 V	5 V, 12 V	100 V or less	A96V	A96	●	—	●	—	—	—	IC circuit	—	
				2-wire				A93V	A93	●	—	●	—	—	—	—	—	Relay, PLC
								A90V	A90	●	—	●	—	—	—	—	—	IC circuit

** Water resistant type auto switches can be mounted on the above models, but in such case SMC cannot guarantee water resistance. Consult with SMC regarding water resistant types with the above model numbers.

* Lead wire length symbols: 0.5 m Nil (Example) M9NW * Solid state auto switches marked with "○" are produced upon receipt of order.
 1 m M (Example) M9NWM * The D-P3DW□ type is available from ø32 to ø63 only.
 3 m L (Example) M9NWL
 5 m Z (Example) M9NWX

* There are other applicable auto switches other than the listed above. For details, refer to page 194.

* For details about auto switches with pre-wired connector, refer to pages 1328 and 1329 in Best Pneumatics No. 2.

Built-in Magnet Cylinder Model

If a built-in magnet cylinder without an auto switch is required, there is no need to enter the symbol for the auto switch.
 (Example) CDQ2L32-10SZ

Single Acting

Type	Special function	Electrical entry	Indicator light	Wiring (Output)	Load voltage		Auto switch model		Lead wire length (m)					Pre-wired connector	Applicable load			
					DC	AC	Perpendicular	In-line	0.5 (Nil)	1 (M)	3 (L)	5 (Z)	None (N)		IC circuit	Relay, PLC		
Solid state auto switch	—	Grommet	Yes	3-wire (NPN)	24 V	5 V, 12 V	—	M9NV	M9N	●	●	●	○	—	○	IC circuit	Relay, PLC	
				3-wire (PNP)				M9PV	M9P	●	●	●	○	—	○			
	2-wire			M9BV				M9B	●	●	●	○	—	○	—	—		
	3-wire (NPN)			M9NWW				M9NW	●	●	●	○	—	○	IC circuit			
	3-wire (PNP)			M9PWV				M9PW	●	●	●	○	—	○				
	2-wire			M9BWW				M9BW	●	●	●	○	—	○	—			
	3-wire (NPN)			M9NAV**				M9NA**	○	○	●	○	—	○	IC circuit			
	3-wire (PNP)			M9PAV**				M9PA**	○	○	●	○	—	○				
	2-wire			M9BAV**				M9BA**	○	○	●	○	—	○	—			
	Reed auto switch			—				Grommet	Yes	3-wire (NPN equivalent)	24 V	5 V, 12 V	100 V or less	A96V	A96	●		—
2-wire		A93V	A93		●	—	●			—				—	—	—	—	Relay, PLC
		A90V	A90		●	—	●			—				—	—	—	—	IC circuit

** Water resistant type auto switches can be mounted on the above models, but in such case SMC cannot guarantee water resistance. Consult with SMC regarding water resistant types with the above model numbers.

* Lead wire length symbols: 0.5 m Nil (Example) M9NW * Solid state auto switches marked with "○" are produced upon receipt of order.
 1 m M (Example) M9NWM
 3 m L (Example) M9NWL
 5 m Z (Example) M9NWX

* There are other applicable auto switches other than the listed above. For details, refer to page 194.

* For details about auto switches with pre-wired connector, refer to pages 1328 and 1329 in Best Pneumatics No. 2.

Refer to pages 1263 to 1371 in Best Pneumatics No. 2 for further information on auto switches.
 Refer to the individual catalog (ES20-201) for the D-P3DW type.

Applicable Auto Switches

Built-in Magnet Cylinder Model

If a built-in magnet cylinder without an auto switch is required, there is no need to enter the symbol for the auto switch.
(Example) CDQ2WL32-25DZ

Double Rod

Type	Special function	Electrical entry	Indicator light	Wiring (Output)	Load voltage		Auto switch model		Lead wire length (m)					Pre-wired connector	Applicable load		
					DC	AC	Perpendicular	In-line	0.5 (Nil)	1 (M)	3 (L)	5 (Z)	None (N)		IC circuit	Relay, PLC	
Solid state auto switch	—	Grommet	Yes	3-wire (NPN)	24 V	5 V, 12 V	—	M9NV	M9N	●	●	●	○	—	○	IC circuit	Relay, PLC
				3-wire (PNP)				M9PV	M9P	●	●	●	○	—	○		
	2-wire			M9BV	M9B	●	●	●	○	—	○	—	—				
	Diagnostic indication (2-color indication)			3-wire (NPN)	M9NVW	M9NW	●	●	●	○	—	○	IC circuit				
				3-wire (PNP)	M9PVW	M9PW	●	●	●	○	—	○					
	Water resistant (2-color indication)			2-wire	M9BWW	M9BW	●	●	●	○	—	○	—	—			
				3-wire (NPN)	M9NAV**	M9NA**	○	○	●	○	—	○	IC circuit				
	Magnetic field resistant (2-color indication)			3-wire (PNP)	M9PAV**	M9PA**	○	○	●	○	—	○					
				2-wire	M9BAV**	M9BA**	○	○	●	○	—	○	—				
	Reed auto switch			—	Grommet	Yes	3-wire (NPN equivalent)	—	5 V	—	A96V	A96	●	—	●	—	
2-wire		24 V	12 V				100 V	A93V	A93	●	—	●	—	—	—	—	Relay, PLC
	Reed auto switch	—	Grommet	No	2-wire	5 V, 12 V	100 V or less	A90V	A90	●	—	●	—	—	—	IC circuit	Relay, PLC

* * Water resistant type auto switches can be mounted on the above models, but in such case SMC cannot guarantee water resistance. Consult with SMC regarding water resistant types with the above model numbers.
 * Lead wire length symbols: 0.5 m Nil (Example) M9NW * Solid state auto switches marked with "○" are produced upon receipt of order.
 1 m M (Example) M9NWM * The D-P3DW□ type is available from ø32 to ø100 only.
 3 m L (Example) M9NWL
 5 m Z (Example) M9NWZ

* There are other applicable auto switches other than the listed above. For details, refer to page 194.
 * For details about auto switches with pre-wired connector, refer to pages 1328 and 1329 in Best Pneumatics No. 2.

Double Rod, Non-Rotating Rod

Type	Special function	Electrical entry	Indicator light	Wiring (Output)	Load voltage		Auto switch model		Lead wire length (m)					Pre-wired connector	Applicable load		
					DC	AC	Perpendicular	In-line	0.5 (Nil)	1 (M)	3 (L)	5 (Z)	None (N)		IC circuit	Relay, PLC	
Solid state auto switch	—	Grommet	Yes	3-wire (NPN)	24 V	5 V, 12 V	—	M9NV	M9N	●	●	●	○	—	○	IC circuit	Relay, PLC
				3-wire (PNP)				M9PV	M9P	●	●	●	○	—	○		
	2-wire			M9BV	M9B	●	●	●	○	—	○	—	—				
	Diagnostic indication (2-color indication)			3-wire (NPN)	M9NVW	M9NW	●	●	●	○	—	○	IC circuit				
				3-wire (PNP)	M9PVW	M9PW	●	●	●	○	—	○					
	Water resistant (2-color indication)			2-wire	M9BWW	M9BW	●	●	●	○	—	○	—	—			
				3-wire (NPN)	M9NAV**	M9NA**	○	○	●	○	—	○	IC circuit				
	Magnetic field resistant (2-color indication)			3-wire (PNP)	M9PAV**	M9PA**	○	○	●	○	—	○					
				2-wire	M9BAV**	M9BA**	○	○	●	○	—	○	—				
	Reed auto switch			—	Grommet	Yes	3-wire (NPN equivalent)	—	5 V	—	A96V	A96	●	—	●	—	
2-wire		24 V	12 V				100 V	A93V	A93	●	—	●	—	—	—	Relay, PLC	
	Reed auto switch	—	Grommet	No	2-wire	5 V, 12 V	100 V or less	A90V	A90	●	—	●	—	—	—	IC circuit	Relay, PLC

* * Water resistant type auto switches can be mounted on the above models, but in such case SMC cannot guarantee water resistance. Consult with SMC regarding water resistant types with the above model numbers.
 * Lead wire length symbols: 0.5 m Nil (Example) M9NW * Solid state auto switches marked with "○" are produced upon receipt of order.
 1 m M (Example) M9NWM * The D-P3DW□ type is available from ø32 to ø63 only.
 3 m L (Example) M9NWL
 5 m Z (Example) M9NWZ

* There are other applicable auto switches other than the listed above. For details, refer to page 194.
 * For details about auto switches with pre-wired connector, refer to pages 1328 and 1329 in Best Pneumatics No. 2.

Refer to pages 1263 to 1371 in Best Pneumatics No. 2 for further information on auto switches.
 Refer to the individual catalog (ES20-201) for the D-P3DW type.

Standard
Single Acting
Double Rod
Axial Piping
Water Resistant
High Lateral Load
End Lock
Clean Series
Copper/Fluorine free series
Construction and Parts
Warranty and Operating Instructions
Mounting and Auto Switches
Made to Order

Applicable Auto Switches

High Lateral Load

Type	Special function	Electrical entry	Indicator light	Wiring (Output)	Load voltage		Auto switch model		Lead wire length (m)					Pre-wired connector	Applicable load		
					DC	AC	Perpendicular	In-line	0.5 (Nil)	1 (M)	3 (L)	5 (Z)	None (N)		IC circuit	Relay, PLC	
Solid state auto switch	—	Grommet	Yes	3-wire (NPN)	24 V	5 V, 12 V	—	M9NV	M9N	●	●	●	○	—	○	IC circuit	Relay, PLC
				3-wire (PNP)				M9PV	M9P	●	●	●	○	—	○		
	2-wire			M9BV	M9B	●	●	●	○	—	○	—	—				
	Diagnostic indication (2-color indication)			3-wire (NPN)	24 V	5 V, 12 V	—	M9NWV	M9NW	●	●	●	○	—	○	IC circuit	
				3-wire (PNP)				M9PWV	M9PW	●	●	●	○	—	○		
	Water resistant (2-color indication)			2-wire	24 V	5 V, 12 V	—	M9BWW	M9BW	●	●	●	○	—	○	—	
				3-wire (NPN)				M9NAV**	M9NA**	○	○	●	○	—	○	IC circuit	
	Magnetic field resistant (2-color indication)			3-wire (PNP)	24 V	5 V, 12 V	—	M9PAV**	M9PA**	○	○	●	○	—	○		
				2-wire				M9BAV**	M9BA**	○	○	●	○	—	○		
	Reed auto switch			—	Grommet	Yes	3-wire (NPN equivalent)	24 V	5 V, 12 V	100 V or less	A96V	A96	●	—	●	—	
2-wire		A93V	A93				●				—	●	—	—	—	—	—
Reed auto switch	—	Grommet	No	2-wire	24 V	5 V, 12 V	100 V or less	A90V	A90	●	—	●	—	—	—	IC circuit	Relay, PLC

** Water resistant type auto switches can be mounted on the above models, but in such case SMC cannot guarantee water resistance. Consult with SMC regarding water resistant types with the above model numbers.

* Lead wire length symbols: 0.5 m Nil (Example) M9NW
 1 m M (Example) M9NWM
 3 m L (Example) M9NWL
 5 m Z (Example) M9NWX
 * Solid state auto switches marked with "○" are produced upon receipt of order.

* There are other applicable auto switches other than the listed above. For details, refer to page 194.

* For details about auto switches with pre-wired connector, refer to pages 1328 and 1329 in Best Pneumatics No. 2.

Water Resistant

Type	Special function	Electrical entry	Indicator light	Wiring (Output)	Load voltage		Auto switch model		Lead wire length (m)					Pre-wired connector	Applicable load	
					DC	AC	Perpendicular	In-line	0.5 (Nil)	1 (M)	3 (L)	5 (Z)	IC circuit		Relay, PLC	
Solid state auto switch	Water resistant (2-color indication)	Grommet	Yes	3-wire (NPN)	24 V	5 V, 12 V	—	M9NAV	M9NA	○	○	●	○	○	IC circuit	Relay, PLC
				3-wire (PNP)				M9PAV	M9PA	○	○	●	○	○		
				2-wire				M9BAV	M9BA	○	○	●	○	○		

* Lead wire length symbols: 0.5 m Nil (Example) M9BA
 1 m M (Example) M9BAM
 3 m L (Example) M9BAL
 5 m Z (Example) M9BAZ
 * Solid state auto switches marked with "○" are produced upon receipt of order.

* For details about auto switches with pre-wired connector, refer to pages 1328 and 1329 in Best Pneumatics No. 2.

Refer to pages 1263 to 1371 in Best Pneumatics No. 2 for further information on auto switches.
 Refer to the individual catalog (ES20-201) for the D-P3DW type.

1 Auto Switch Proper Mounting Position (Detection at Stroke End) and its Mounting Height

Applicable Cylinder Series: (N)CDQ2, (N)CDQ2W, (N)CDQ2□□□□-□S/-□T (Single acting), (N)CDQ2, (N)CDQ2W (Large bore size), (N)CDQ2K, (N)CDQ2KW (Non-rotating rod), (N)CDQ2 (Long stroke), CDQ2□S (High lateral load), CDQ2□R/□V (Water resistant)

- D-A9□
- D-M9□
- D-M9□W
- D-M9□AL
- D-A9□V
- D-M9□V
- D-M9□WV
- D-M9□AVL

ø12 to ø25

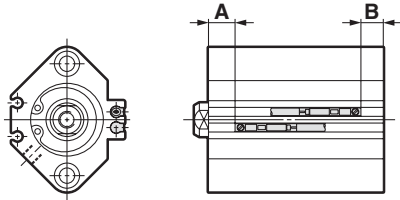

ø32 to ø200

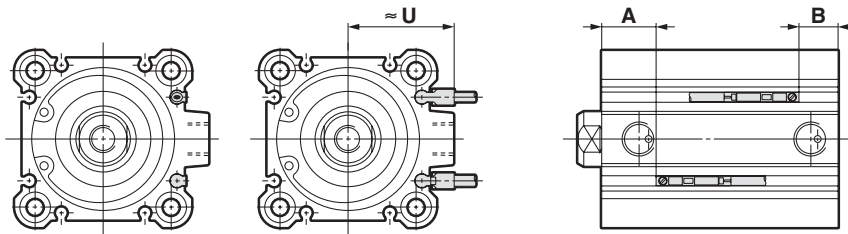

- D-A7□
- D-A80
- D-A7□H
- D-A80H
- D-F7□
- D-J79
- D-F7□W
- D-J79W
- D-F79F

- D-F7NTL
- D-F7BAL
- D-A73C
- D-A80C
- D-J79C
- D-A79W
- D-F7□WV
- D-F7□V
- D-F7BAVL

ø12 to ø25

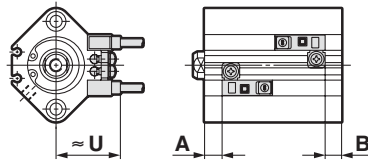

ø32 to ø160

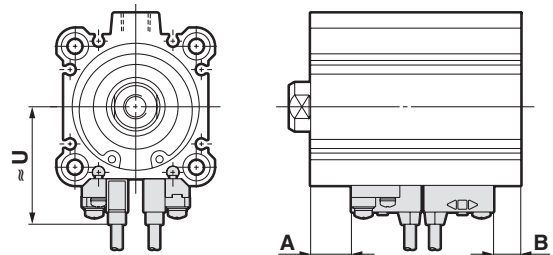

- D-P3DW□

ø32 to ø100

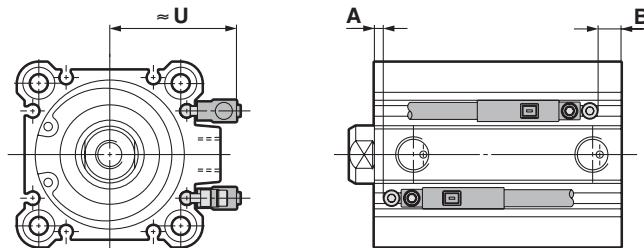

Auto Switch Proper Mounting Position

Applicable Cylinder Series: (N)CDQ2 (Double acting, Single rod) (mm)

Auto switch model Bore size	D-A9□ D-A9□V		D-M9□ D-M9□V D-M9□W D-M9□WV D-M9□AL D-M9□AVL		D-A73 D-A80		D-A72/A7□H/A80H D-A73C/A80C/F7□ D-F79F/J79/F7□V D-J79C/F7□W D-J79W/F7□WV D-F7BAVL/F7BAL		D-F7NTL		D-A79W		D-P3DW□	
	A	B	A	B	A	B	A	B	A	B	A	B	A	B
12	2	3	6	7	4.5	5.5	5	6	10	11	2	3	—	—
16	5	2.5	9	6.5	7.5	5	8	5.5	13	10.5	5	2.5	—	—
20	5	3.5	9	7.5	7.5	6	8	6.5	13	11.5	5	3.5	—	—
25	5.5	4	9.5	8	8	6.5	8.5	7	13.5	12	5.5	4	—	—
32	8	5	12	9	9	6	9.5	6.5	14.5	11.5	6.5	3.5	2.5	0
40	12	7.5	16	11.5	13	8.5	13.5	9	18.5	14	10.5	6	6.5	2
50	10	10.5	14	14.5	11	11.5	11.5	12	16.5	17	8.5	9	4.5	4.5
63	12.5	13.5	16.5	17.5	13.5	14.5	14	15	19	20	11	12	7	7.5
80	15.5	18	19.5	22	16.5	19	17	19.5	22	24.5	14	16.5	10	12
100	20	23	24	27	21	24	21.5	24.5	26.5	29.5	18.5	21.5	14.5	17.5

Applicable Cylinder Series: (N)CDQ2W (Double acting, Double rod) (mm)

Auto switch model Bore size	D-A9□ D-A9□V		D-M9□ D-M9□V D-M9□W D-M9□WV D-M9□AL D-M9□AVL		D-A73 D-A80		D-A72/A7□H/A80H D-A73C/A80C/F7□ D-F79F/J79/F7□V D-J79C/F7□W D-J79W/F7□WV D-F7BAVL/F7BAL		D-F7NTL		D-A79W		D-P3DW□	
	A	B	A	B	A	B	A	B	A	B	A	B	A	B
12	2	7.5	6	11.5	4.5	10	5	10.5	10	15.5	2	7.5	—	—
16	5	8	9	12	7.5	10.5	8	11	13	16	5	8	—	—
20	5	10	9	14	7.5	12.5	8	13	13	18	5	10	—	—
25	5.5	10.5	9.5	14.5	8	13	8.5	13.5	13.5	18.5	5.5	10.5	—	—
32	8	12.5	12	16.5	9	13.5	9.5	14	14.5	19	6.5	11	2.5	7
40	12	18	16	22	13	19	13.5	19.5	18.5	24.5	10.5	16.5	6.5	12.5
50	10	20.5	14	24.5	11	21.5	11.5	22	16.5	27	8.5	19	4.5	14.5
63	12.5	19.5	16.5	23.5	13.5	20.5	14	21	19	26	11	18	7	13.5
80	15.5	25.5	19.5	29.5	16.5	26.5	17	27	22	32	14	24	10	19.5
100	20	30.5	24	34.5	21	31.5	21.5	32	26.5	37	18.5	29	14.5	25

Applicable Cylinder Series: (N)CDQ2□□□-□S/□T (Single acting) (mm)

Auto switch model Bore size	D-A9□ D-A9□V		D-M9□ D-M9□V D-M9□W D-M9□WV D-M9□AL D-M9□AVL		D-A73 D-A80		D-A72/A7□H/A80H D-A73C/A80C/F7□ D-F79F/J79/F7□V D-J79C/F7□W D-J79W/F7□WV D-F7BAVL/F7BAL		D-F7NTL		D-A79W	
	A	B	A	B	A	B	A	B	A	B	A	B
12	2	3 (7.5)	6	7 (11.5)	4.5	5.5 (10)	5	6 (10.5)	10	11 (15.5)	2	3 (7.5)
16	5 (3)	2.5 (4.5)	9 (7)	6.5 (8.5)	7.5 (5.5)	5 (7)	8 (6)	5.5 (7.5)	13 (11)	10.5 (12.5)	5 (3)	2.5 (4.5)
20	5	3.5	9	7.5	7.5	6	8	6.5	13	11.5	5	3.5
25	5.5	4	9.5	8	8	6.5	8.5	7	13.5	12	5.5	4
32	8	5	12	9	9	6	9.5	6.5	14.5	11.5	6.5	3.5
40	12	7.5	16	11.5	13	8.5	13.5	9	18.5	14	10.5	6
50	10	10.5	14	14.5	11	11.5	11.5	12	16.5	17	8.5	9

() : Spring extend type

Note) Adjust the auto switch after confirming the operating conditions in the actual setting.

- Standard
- Single Acting
- Double Rod
- Axial Piping
- Water Resistant
- High Lateral Load
- End Lock
- Clean Series
- Copper/Fluorine free series
- Construction and Parts
- Warranty and Operating Instructions
- Mounting and Auto Switches
- Made to Order

1 Auto Switch Proper Mounting Position (Detection at Stroke End) and its Mounting Height

Auto Switch Proper Mounting Position

Applicable Cylinder Series: (N)CDQ2, (N)CDQ2W (Large bore size)

(mm)

Auto switch model	D-A9□ D-A9□V		D-M9□ D-M9□V D-M9□W D-M9□WV D-M9□AL D-M9□AVL		D-A73 D-A80		D-A72/A7□H/A80H D-A73C/A80C D-F7□/F7□V D-F79F/F7□W D-F7□WV/J79 D-J79W/J79C D-F7BAL D-F7BAVL		D-A79W		D-F7NTL	
	A	B	A	B	A	B	A	B	A	B	A	B
Bore size												
125	30	30	34	34	32.5	32.5	33	33	30	30	38	38
140	30	30	34	34	32.5	32.5	33	33	30	30	38	38
160	34	34	38	38	36.5	36.5	37	37	34	34	42	42
180	40.5	40.5	44.5	44.5	—	—	—	—	—	—	—	—
200	43.5	43.5	47.5	47.5	—	—	—	—	—	—	—	—

Applicable Cylinder Series: (N)CDQ2 (Long stroke)

(mm)

Auto switch model	D-A9□ D-A9□V		D-M9□ D-M9□V D-M9□W D-M9□WV D-M9□AL D-M9□AVL		D-A73 D-A80		D-A72/A7□H/A80H D-A73C/A80C/F7□ D-F79F/J79/F7□V D-J79C/F7□W D-J79W/F7□WV D-F7BAVL/F7BAL		D-F7NTL		D-A79W		D-P3DW□	
	A	B	A	B	A	B	A	B	A	B	A	B	A	B
Bore size														
32	8.5	16.5	12.5	20.5	9.5	17.5	10	18	15	23	7	15	3	11
40	12	22.5	16	26.5	13	23.5	13.5	24	18.5	29	10.5	21	6.5	17
50	10	25.5	14	29.5	11	26.5	11.5	27	16.5	32	8.5	24	4.5	19.5
63	12.5	24.5	16.5	28.5	13.5	25.5	14	26	19	31	11	23	7	18.5
80	15.5	30.5	19.5	34.5	16.5	31.5	17	32	22	37	14	29	10	24.5
100	18.5	37	22.5	41	19.5	38	20	38.5	25	43.5	17	35.5	13	31

Applicable Cylinder Series: (N)CDQ2K (Non-rotating rod)

(mm)

Auto switch model	D-A9□ D-A9□V		D-M9□ D-M9□V D-M9□W D-M9□WV D-M9□AL D-M9□AVL		D-A73 D-A80		D-A72/A7□H/A80H D-A73C/A80C/F7□ D-F79F/J79/F7□V D-J79C/F7□W D-J79W/F7□WV D-F7BAVL/F7BAL		D-F7NTL		D-A79W		D-P3DW□	
	A	B	A	B	A	B	A	B	A	B	A	B	A	B
Bore size														
12	7	3	11	7	9.5	5.5	10	6	15	11	7	3	—	—
16	10	2.5	14	6.5	12.5	5	13	5.5	18	10.5	10	2.5	—	—
20	13	3.5	17	7.5	15.5	6	16	6.5	21	11.5	13	3.5	—	—
25	13.5	4	17.5	8	16	6.5	16.5	7	21.5	12	13	4	—	—
32	17	5	21	9	18	6	18.5	6.5	23.5	11.5	15.5	3.5	11.5	0
40	12	7.5	16	11.5	13	8.5	13.5	9	18.5	14	10.5	6	6.5	2
50	10	10.5	14	14.5	11	11.5	11.5	12	16.5	17	8.5	9	4.5	4.5
63	12.5	13.5	16.5	17.5	13.5	14.5	14	15	19	20	11	12	7	7.5

Applicable Cylinder Series: (N)CDQ2KW (Double Rod, Non-rotating rod)

(mm)

Auto switch model	D-A9□ D-A9□V		D-M9□ D-M9□V D-M9□W D-M9□WV D-M9□AL D-M9□AVL		D-A73 D-A80		D-A72/A7□H/A80H D-A73C/A80C/F7□ D-F79F/J79/F7□V D-J79C/F7□W D-J79W/F7□WV D-F7BAVL/F7BAL		D-F7NTL		D-A79W		D-P3DW□	
	A	B	A	B	A	B	A	B	A	B	A	B	A	B
Bore size														
12	7.5	7.5	11.5	11.5	9.5	10	10	10.5	15	15.5	7.5	7.5	—	—
16	10	8	14	12	12.5	10.5	13	11	18	16	10	8	—	—
20	13	10	17	14	15.5	12.5	16	13	21	18	13	10	—	—
25	13.5	10.5	17.5	14.5	16	13	16.5	13.5	21.5	18.5	13.5	10.5	—	—
32	17	12.5	21	16.5	18	13.5	18.5	14	23.5	19	15.5	11	11.5	7
40	12	18	16	22	13	19	13.5	19.5	18.5	24.5	10.5	16.5	6.5	12.5
50	10	20.5	14	24.5	11	21.5	11.5	22	16.5	27	8.5	19	4.5	14.5
63	12.5	19.5	16.5	23.5	13.5	20.5	14	21	19	26	11	18	7	13.5

Note) Adjust the auto switch after confirming the operating conditions in the actual setting.

(mm)

Applicable Cylinder Series: CDQ2□S (High lateral load)

Auto switch model	D-A9□ D-A9□V		D-M9□ D-M9□V D-M9□W D-M9□WV D-M9□AL D-M9□AVL		D-A73 D-A80		D-A72/A7□H/A80H D-A73C/A80C/F7□ D-F79F/J79/F7□V D-J79C/F7□W D-J79W/F7□WV D-F7BAVL/F7BAL		D-F7NTL		D-A79W		D-P3DW□	
	A	B	A	B	A	B	A	B	A	B	A	B	A	B
32	14	9	18	13	15	10	15.5	10.5	20.5	15.5	12.5	7.5	8	3.5
40	17.5	12	21.5	16	18.5	13	19	13.5	24	18.5	16	10.5	11.5	6.5
50	15	15.5	19	19.5	16	16.5	16.5	17	21.5	22	13.5	14	9.5	9.5
63	17.5	18.5	21.5	22.5	18.5	19.5	19	20	24	25	16	17	12	12.5
80	20.5	23	24.5	27	21.5	24	22	24.5	27	29.5	19	21.5	15	17
100	23.5	29.5	27.5	33.5	24.5	30.5	25	31	30	36	22	28	18	23.5

Note) Adjust the auto switch after confirming the operating conditions in the actual setting.

Applicable Cylinder Series: CDQ2□R/□V (Water resistant)

Auto switch model	D-M9□AL D-M9□AVL		D-F7BAL D-F7BAVL	
	A	B	A	B
20	19	7.5	18	6.5
25	19.5	8	18	7
32	22	9	19.5	6.5
40	16	11.5	13.5	9
50	14	14.5	11.5	12
63	16.5	17.5	14	15
80	19.5	22	17	19.5
100	24	27	21.5	24.5

Note) Adjust the auto switch after confirming the operating conditions in the actual setting.

Auto Switch Mounting Height

Applicable Cylinder Series: (N)CDQ2, (N)CDQ2W, (N)CDQ2□□□□S/□T (Single acting), (N)CDQ2K, (N)CDQ2KW (Non-rotating rod) (N)CDQ2 (Long stroke), CDQ2□S (High lateral load) CDQ2□R/□V (Water resistant)

Auto switch model	D-M9□V	D-A9□V	D-F7□/J79 D-F7□W/J79W D-F7BAL D-F79F/F7NTL D-A7□H/A80H	D-F7□V D-F7□WV	D-J79C	D-A7□ D-A80	D-A73C D-A80C	D-A79W	D-P3DW□
	U	U	U	U	U	U	U	U	U
12	21.5	19	21.5	23.5	26.5	21	27.5	24.5	—
16	22.5	20	22.5	24.5	27.5	22	28.5	25.5	—
20	25	23	25.5	27.5	30	24.5	31	28	—
25	28	26	28	30.5	32.5	27.5	34	31	—
32	30	27.5	36	36.5	39.5	34	40.5	37.5	33
40	32	30	38	40	42.5	37.5	43.5	40.5	36.5
50	37.5	35	43.5	45	48	43	49	46	42
63	42.5	40.5	48.5	50.5	53.5	48	54.5	51.5	47
80	51	49	57	59	61.5	56.5	62.5	59.5	55.5
100	59	57	65.5	67	70	64.5	71	68	65.5

* The applicable auto switches for the CDQ2□R/□V (water resistant) are the D-M9□A(V)L type.

* The D-P3DW□ type is available from ø32 to ø100.

Applicable Cylinder Series: (N)CDQ2, (N)CDQ2W (Large bore size)

Auto switch model	D-M9□V D-M9□WV D-M9□AVL	D-A9□V	D-A7□ D-A80	D-A7□H/A80H D-F7□/J79 D-F7□W/J79W D-F7BAL D-F79F/F7NTL	D-A73C D-A80C	D-F7□V D-F7□WV D-F7BAVL	D-J79C	D-A79W
	U	U	U	U	U	U	U	U
125	69.5	67.5	75.5	76.5	82.5	79	81	78
140	76.5	74.5	82.5	83.5	89.5	86	88	85
160	85.5	83.5	91.5	92.5	98.5	95	97	94
180	105.5	103.5	—	—	—	—	—	—
200	112.5	110.5	—	—	—	—	—	—

- Standard
- Single Acting
- Double Rod
- Axial Piping
- Water Resistant
- High Lateral Load
- End Lock
- Clean Series
- Copper/Fluorine free series
- Construction and Parts
- Warranty and Operating Instructions
- Mounting and Auto Switches
- Made to Order

2 Minimum Stroke for Auto Switch Mounting

Applicable Cylinder Series: (N)CDQ2, (N)CDQ2W, (N)CDQ2□□□-□S/□T (Single acting), (N)CDQ2K, (N)CDQ2KW (Non-rotating rod), (N)CDQ2 (Long stroke), CDQ2□S (High lateral load), CDQ2□R/□V (Water resistant) (mm)

Number of auto switches	D-M9□V D-F7□V D-J79C	D-A9□V D-A7□ D-A80 D-A73C D-A80C	D-A9□	D-M9□WV D-M9□AVL* D-F7□WV D-F7BAVL	D-M9□ D-M9□W D-M9□AL* D-A7□H D-A80H D-F7□ D-J79	D-A79W	D-F7□W D-J79W D-F7BAL D-F79F D-F7NTL	D-P3DW□
With 1 pc.	5	5	10	10	15	15	20	15
With 2 pcs.	5	10	10	15	15	20	20	15

* The applicable auto switches for the CDQ2□R/□V (water resistant) are the D-M9□A(V)L type.

Applicable Cylinder Series: (N)CDQ2, (N)CDQ2W (Large bore size) (mm)

Number of auto switches	D-M9□ D-M9□V D-F7□ D-F7□V D-J79 D-J79C	D-A9□ D-A9□V D-A7□ D-A80 D-A73C D-A80C D-A7□H D-A80H	D-M9□W D-M9□WV D-M9□AL D-M9□AVL	D-F7□W D-F7□WV D-J79W D-F7BAL D-F7BAVL D-F7NTL D-F79F	D-A79W
With 1 pc.	5	5	10	15	15
With 2 pcs.	5	10	15	20	20

3 Operating Range

Applicable Cylinder Series: (N)CDQ2, (N)CDQ2W, (N)CDQ2□□□-□S/□T (Single acting), (N)CDQ2K, (N)CDQ2KW (Non-rotating rod), (N)CDQ2 (Long stroke), CDQ2□S (High lateral load), CDQ2□R/□V (Water resistant) (mm)

Auto switch model	Bore size														
	12	16	20	25	32	40	50	63	80	100	125	140	160	180	200
D-A9□(V)	7.5	9.5	10	9	9	9.5	9.5	11	10.5	10.5	13.5	12.5	12	13	12.5
D-M9□(V) D-M9□W(V) D-M9□A(V)L*	3	5	5.5	5.5	5	5	6	6.5	7	7.5	7.5	8	7.5	7.5	8.5
D-A7□(H)(C) D-A80□(H)(C)	9.5	12	12	11	10.5	11.5	11	13	11.5	11.5	16.5	15	14.5	—	—
D-A79W	13	14.5	15.5	14	14	15.5	14.5	17	15	15.5	19.5	18	17.5	—	—
D-F7□(V) D-J79(C) D-F7□W(V) D-F7BA(V)L D-F7NTL D-F79F	4.5	5.5	5	5	5	5	5	6	7	8	7.5	7.5	7.5	—	—
D-P3DW□	—	—	—	—	3	4.5	4.5	6	5.5	6.5	—	—	—	—	—

* Values which include hysteresis are for guideline purposes only, they are not a guarantee (assuming approximately±30% dispersion) and may change substantially depending on the ambient environment.

* The applicable auto switches for the CDQ2□R/□V (water resistant) are the D-M9□A(V)L type.

4 Auto Switch Mounting Brackets/Part No.

Applicable Cylinder Series: (N)CDQ2, (N)CDQ2W, (N)CDQ2□□□□□S/□T (Single acting), (N)CDQ2, (N)CDQ2W (Large bore size), (N)CDQ2K, (N)CDQ2KW (Non-rotating rod), (N)CDQ2 (Long stroke), CDQ2□S (High lateral load), CDQ2□R/□V (Water resistant)

Applicable auto switch	D-M9□/M9□V D-M9□W/M9□WV D-M9□AL/M9□AVL D-A9□/A9□V	D-F7□/F7□V/J79/J79C/F7□W/J79W/F7□WV D-F7BAL/F7BAVL/F79F/F7NTL D-A7□/A80/A7□H/A80H/A73C/A80C/A79W		D-P3DW□								
Bore size (mm)	ø12 to ø200	ø12 to ø25	ø32 to ø160	ø32 to ø100								
Auto switch mounting bracket part no.	—	BQ4-012	BQ5-032	BQ3-032S								
Auto switch mounting bracket fitting parts lineup/weight	—	① Auto switch mounting screw (M2.5 x 8L) ② Auto switch mounting nut Weight: 1.5 g	① Auto switch fixing screw (M2.5 x 10L) ② Auto switch mounting screw (M3 x 8L) ③ Auto switch spacer ④ Auto switch mounting nut Weight: 3.5 g	① Hexagon socket head cap screw (M2.5 x 6L) ② Hexagon socket head cap screw (M2.5 x 9L) ③ Auto switch mounting bracket (nut) Weight: 2.5 g								
When requesting the enclosure of the auto switch mounting brackets (2 pcs.) with the cylinder for shipment, add "BQ" to the end of the cylinder model number. Standard model no. +BQ Example) CDQ2B32-30DZ-BQ/ CDQ2B32-30DZ-BQ-XC4 (Made to Order)												
Auto switch mounting surface	Surfaces with auto switch mounting slot	Auto switch mounting rail side only	A/B/C side except port side	Surfaces with auto switch mounting slot								
Mounting of auto switch	<p>Auto switch mounting screw</p> <p>Auto switch</p> <p>• When tightening the auto switch mounting screw, use a watchmaker's screwdriver with a handle 5 to 6mm in diameter.</p> <p>Tightening torque for auto switch mounting screw (N·m)</p> <table border="1"> <thead> <tr> <th>Auto switch model</th> <th>Tightening torque</th> </tr> </thead> <tbody> <tr> <td>D-M9□(V)</td> <td rowspan="3">0.05 to 0.15</td> </tr> <tr> <td>D-M9□W(V)</td> </tr> <tr> <td>D-M9□A(V)L</td> </tr> <tr> <td>D-A9□(V)</td> <td>0.10 to 0.20</td> </tr> </tbody> </table>	Auto switch model	Tightening torque	D-M9□(V)	0.05 to 0.15	D-M9□W(V)	D-M9□A(V)L	D-A9□(V)	0.10 to 0.20	<ol style="list-style-type: none"> Insert the nut into the auto switch mounting slot on the cylinder tube, and place it in the roughly estimated setting position. Engage the ridge on the auto switch mounting arm with the recess in the cylinder tube rail, and slide it to the position of the nut. Gently screw the auto switch mounting screw into the thread of the auto switch mounting nut through the mounting hole on the auto switch mounting arm. Confirm where the mounting position is, and tighten the auto switch mounting screw to fix the auto switch. The tightening torque of the M2.5 screw must be 0.25 to 0.35 N·m. The detection position can be changed under the conditions in step 3. <p>③ Auto switch mounting screw (M2.5 x 0.45 x 8L)</p> <p>② Auto switch</p> <p>① Auto switch mounting bracket (nut)</p>	<ol style="list-style-type: none"> Insert the nut into the auto switch mounting slot on the cylinder tube, and place it in the roughly estimated setting position. With the lower tapered part of the auto switch spacer facing the outside of the cylinder tube, line up the M2.5 through hole with the M2.5 female thread of the auto switch mounting nut. Gently screw the auto switch mounting nut fixing screw (M2.5) into the thread of the auto switch mounting nut through the mounting hole. Engage the ridge on the auto switch mounting arm with the recess in the auto switch spacer. Tighten the auto switch mounting screw (M3) to fix the auto switch. The tightening torque of the M3 screw must be 0.35 to 0.45 N·m. Confirm where the mounting position is, and tighten the auto switch fixing screw (M2.5) to fix the auto switch mounting nut. The tightening torque must be 0.25 to 0.35 N·m. The detection position can be changed under the conditions in step 5. <p>⑤ Auto switch mounting screw (M3 x 0.5 x 8L)</p> <p>④ Auto switch</p> <p>③ Auto switch fixing screw (M2.5 x 0.45 x 10L)</p> <p>② Auto switch spacer</p> <p>① Auto switch mounting bracket (nut)</p>	<ol style="list-style-type: none"> Insert the protrusion on the bottom of the auto switch into the mating part of the auto switch mounting bracket and fix the auto switch and the auto switch mounting bracket temporarily by tightening the hexagon socket head cap screw (M2.5 x 9L) 1 to 2 turns. Insert the temporarily tightened mounting bracket into the mating groove of the cylinder tube, and slide the auto switch onto the cylinder tube through the groove. Check the detecting position of the auto switch and fix the auto switch firmly with the hexagon socket head cap screw (M2.5 x 6L, M2.5 x 9L).* If the detecting position is changed, go back to step 2. <p>* The hexagon socket head cap screw (M2.5 x 6L) is used to fix the mounting bracket and cylinder tube. This enables the replacement of the auto switch without adjusting its position.</p> <p>Note 1) Ensure that the auto switch is covered with the mating groove to protect the auto switch.</p> <p>Note 2) The tightening torque of the hexagon socket head cap screw (M2.5 x 9L) must be 0.2 to 0.3 N·m.</p> <p>Note 3) Tighten the hexagon socket head cap screws evenly.</p> <p>Hexagon socket head cap screw (M2.5 x 9L)</p> <p>Hexagon socket head cap screw (M2.5 x 6L)</p> <p>Protrusion</p> <p>Auto switch mounting bracket</p>
		Auto switch model	Tightening torque									
D-M9□(V)	0.05 to 0.15											
D-M9□W(V)												
D-M9□A(V)L												
D-A9□(V)	0.10 to 0.20											

Note) Auto switch mounting bracket and auto switch are enclosed with the cylinder for shipment. For an environment that needs the water resistant auto switch, select the D-M9□A(V)L type. Auto switch mounting bracket for the D-F7BA(V)L type uses BQ4-012 and BQ5-032 normal specifications (metal screw).
* The auto switches applicable to the CDQ2□R/□V (water resistant) is the D-M9□A(V)L type.

Standard

Single Acting

Double Rod

Axial Piping

Water Resistant

High Lateral Load

End Lock

Clean Series

Copper/Fluorine free series

Construction and Parts

Warranty and Operating Instructions

Mounting and Auto Switches

Made to Order

Other than the applicable auto switches listed in “How to Order”, the following auto switches are mountable. Refer to pages 1263 to 1371 in Best Pneumatics No. 2 for detailed specifications.

Applicable Cylinder Series: (N)CDQ2, (N)CDQ2W, (N)CDQ2□□□□□S/□T (Single acting), (N)CDQ2, (N)CDQ2W (Large bore size), (N)CDQ2K, (N)CDQ2KW, (Non-rotating rod), (N)CDQ2 (Long stroke), CDQ2□S (High lateral load)

Auto switch type	Model	Electrical entry	Features	Applicable bore size
Reed	D-A72	Grommet (Perpendicular)	—	ø12 to ø100 ø125 to ø160
	D-A73		—	
	D-A80		Without indicator light	
	D-A79W		Diagnostic indication (2-color indication)	
	D-A73C	Connector (Perpendicular)	—	
	D-A80C		Without indicator light	
	D-A72H		—	
	D-A73H, A76H	Grommet (In-line)	—	
	D-A80H		Without indicator light	
Solid state	D-F7NV, F7PV, F7BV	Grommet (Perpendicular)	—	
	D-F7NWV, F7BWV		Diagnostic indication (2-color indication)	
	D-F7BAVL		Water resistant (2-color indication)	
	D-J79C	Connector (Perpendicular)	—	
	D-F79, F7P, J79	Grommet (In-line)	—	
	D-F79W, F7PW, J79W		Diagnostic indication (2-color indication)	
	D-F7BAL		Water resistant (2-color indication)	
	D-F79F		Diagnostic indication (2-color indication)	
	D-F7NTL		With timer	

* With pre-wired connector is also available for solid state auto switches. For details, refer to pages 1328 and 1329 in Best Pneumatics No. 2.

* Normally closed (NC = b contact) solid state auto switches (D-F9G/F9H) are also available. For details, refer to page 1290 in Best Pneumatics No. 2.

* Trimmer auto switch (D-F7K) and heat resistant solid state auto switch (D-F7NJL) are not available.

1 Auto Switch Proper Mounting Position (Detection at Stroke End) and its Mounting Height

Applicable Cylinder Series: CDQP2, CDQP2□□□□-□S/-□T (Axial piping)

- D-A9□
- D-M9□
- D-M9□W
- D-M9□AL
- D-A9□V
- D-M9□V
- D-M9□WV
- D-M9□AVL

ø12 to ø25

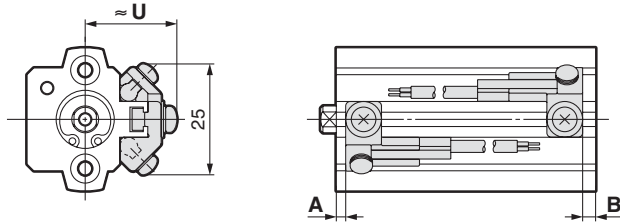

ø32 to ø100

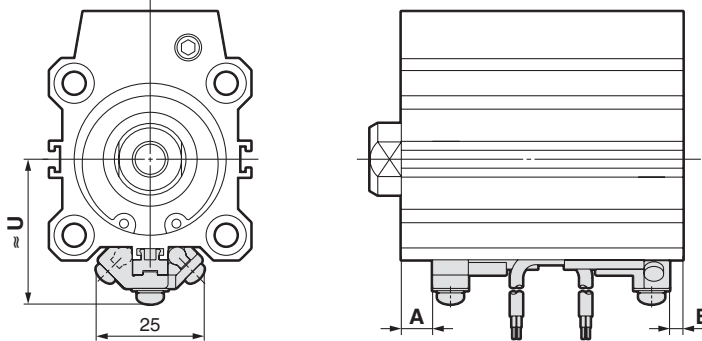

- D-A7□
- D-A80
- D-A7□H
- D-A80H
- D-F7□
- D-J79
- D-F7□W
- D-J79W
- D-F79F

- D-F7NTL
- D-F7BAL
- D-A73C
- D-A80C
- D-J79C
- D-A79W
- D-F7□WV
- D-F7□V
- D-F7BAVL

ø12 to ø25

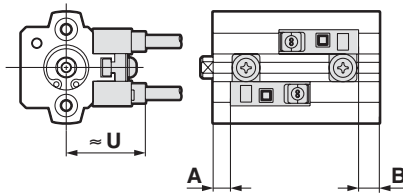

ø32 to ø100

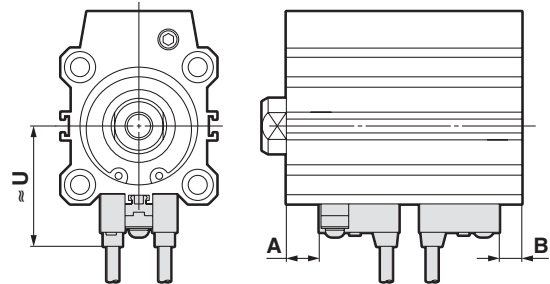

D-P4DWL

ø40 to ø100

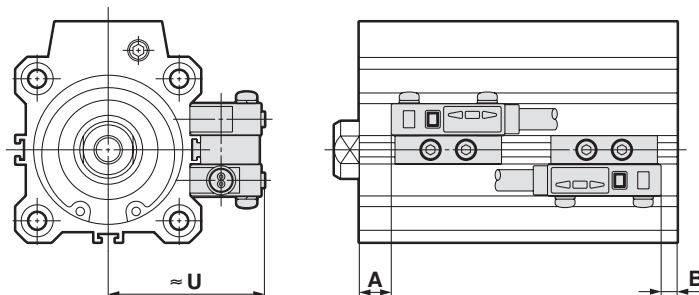

Auto Switch Proper Mounting Position

Applicable Cylinder Series: CDQP2 (Axial piping)

(mm)

Auto switch model	D-A9□ D-A9□V		D-M9□ D-M9□V D-M9□W D-M9□WV D-M9□AL D-M9□AVL		D-A73 D-A80		D-A72/A7□H/A80H D-A73C/A80C/F7□ D-F79F/J79/F7□V D-J79C/F7□W D-J79W/F7□WV D-F7BAVL/F7BAL		D-F7NTL		D-A79W		D-P4DWL	
	A	B	A	B	A	B	A	B	A	B	A	B	A	B
Bore size														
12	2	3	6	7	4.5	5.5	5	6	10	11	2	3	—	—
16	5	2.5	9	6.5	7.5	5	8	5.5	13	10.5	5	2.5	—	—
20	5	3.5	9	7.5	7.5	6.5	8	7	13	12	5	4	—	—
25	5.5	4	9.5	8	7.5	7	8	7.5	13	12.5	5	4.5	—	—
32	6.5	3.5	10.5	7.5	9	6	9.5	6.5	14.5	11.5	6.5	3.5	—	—
40	10.5	6	14.5	10	13	8.5	13.5	9	18.5	14	10.5	6	9	4.5
50	8.5	9	12.5	13	11	11.5	11.5	12	16.5	17	8.5	9	7	7.5
63	11	12	15	16	13.5	14.5	14	15	19	20	11	12	9.5	10.5
80	14	16.5	18	20.5	17.5	18	18	18.5	23	23.5	15	15.5	13.5	14
100	18.5	21.5	22.5	25.5	21	24	21.5	24.5	26.5	29.5	18.5	21.5	17	20

Note) Adjust the auto switch after confirming the operating conditions in the actual setting.

Applicable Cylinder Series: CDQP2□□□□-□S/□T (Axial piping, Single acting)

(mm)

Auto switch model	D-A9□ D-A9□V		D-M9□ D-M9□V D-M9□W D-M9□WV D-M9□AL D-M9□AVL		D-A73 D-A80		D-A72/A7□H/A80H D-A73C/A80C/F7□ D-F79F/J79/F7□V D-J79C/F7□W D-J79W/F7□WV D-F7BAVL/F7BAL		D-F7NTL		D-A79W	
	A	B	A	B	A	B	A	B	A	B	A	B
Bore size												
12	2	3 (7)	6	7 (11)	4.5	5.5 (10)	5	6 (10.5)	10	11 (15.5)	2	3 (7.5)
16	5 (3)	2.5 (4.5)	9 (7)	6.5 (8.5)	7.5 (5.5)	5 (7)	8 (6)	5.5 (7.5)	13 (11)	10.5 (12.5)	5 (3)	2.5 (4.5)
20	5	3.5	9	7.5	7.5	6.5	8	7	13	12	5	4
25	5.5	4	9.5	8	7.5	7	8	7.5	13	12.5	5	4.5
32	6.5	3.5	10.5	7.5	9	6	9.5	6.5	14.5	11.5	6.5	3.5
40	10.5	6	14.5	10	13	8.5	13.5	9	18.5	14	10.5	6
50	8.5	9	12.5	13	11	11.5	11.5	12	16.5	17	8.5	9

() : Spring extend type

Note) Adjust the auto switch after confirming the operating conditions in the actual setting.

Applicable Cylinder Series: CDQP2, CDQP2□□□□-□S/□T (Axial piping)

(mm)

Auto switch model	D-A9□ D-A9□V D-M9□ D-M9□V D-M9□W D-M9□WV D-M9□AL D-M9□AVL		D-A7□ D-A80		D-A7□H D-A80H D-F7□ D-J79 D-F7□W D-J79W D-F7BAL D-F79F D-F7NTL		D-A73C D-A80C		D-F7□V D-F7□WV D-F7BAVL		D-J79C		D-A79W		D-P4DWL	
	U	U	U	U	U	U	U	U	U	U	U	U	U	U		
Bore size																
12	20.5	19.5	20.5	26.5	23	26	22	—								
16	23.5	22.5	23.5	29.5	26	29	25	—								
20	25.5	24.5	25.5	31.5	28	31	27	—								
25	28.5	27.5	28.5	34.5	31	34	30	—								
32	32.5	31.5	32.5	38.5	35	38	34	—								
40	36	35	36	42	38.5	41.5	37.5	44								
50	42	41	42	48	44.5	47.5	43.5	50								
63	48.5	47.5	48.5	54.5	51	54	50	56.5								
80	58.5	57.5	58.5	64.5	61	64	60	66.5								
100	68.5	67.5	68.5	74.5	71	74	70	76.5								

- Standard
- Single Acting
- Double Rod
- Axial Piping
- Water Resistant
- High Lateral Load
- End Lock
- Clean Series
- Copper/Fluorine free series
- Construction and Parts
- Warranty and Operating Instructions
- Mounting and Auto Switches
- Made to Order

Series CDQP2 Axial Piping

With Auto Switch 2

2 Minimum Stroke for Auto Switch Mounting

Applicable Cylinder Series: CDQP2, CDQP2□□□-□S/-□T (Axial piping)

(mm)

Number of auto switches	D-M9□V D-F7□V D-J79C	D-A9□V D-A7□ D-A80 D-A73C D-A80C	D-A9□	D-M9□WV D-M9□AVL D-F7□WV D-F7BAVL	D-M9□ D-M9□W D-M9□AL D-A7□H D-A80H D-F7□ D-J79	D-A79W	D-F7□W D-J79W D-F7BAL D-F79F D-F7NTL	D-P4DWL
With 1 pc.	5	5	10	10	15	15	20	15
With 2 pcs.	5	10	10	15	15	20	20	15

3 Operating Range

Applicable Cylinder Series: CDQP2, CDQP2□□□-□S/-□T (Axial piping)

(mm)

Auto switch model	Bore size									
	12	16	20	25	32	40	50	63	80	100
D-A9□(V)	7.5	9.5	9	9	9.5	9.5	8.5	11	10	10.5
D-M9□(V) D-M9□W(V) D-M9□A(V)L	3.5	5	5	5	5.5	5.5	6	6.5	7	7
D-A7□(H)(C) D-A80□(H)(C)	10	12	12	12	12	11	10	12	12	13
D-A79W	13	13	13	13	13	14	14	16	15	17
D-F7□(V) D-J79(C) D-F7□W(V) D-F7BA(V)L D-F7NTL D-F79F	5.5	6	5.5	5	6	6	6	6.5	6.5	7
D-P4DWL	-	-	-	-	-	5	5	5	5	5.5

* Values which include hysteresis are for guideline purposes only, they are not a guarantee (assuming approximately ±30% dispersion) and may change substantially depending on the ambient environment.

4 Auto Switch Mounting Brackets/Part No.

Applicable Cylinder Series: CDQP2, CDQP2□□□□-□S/-□T (Axial piping)

Auto switch mounting surface	Bore size (mm)	
	ø12, ø16, ø20, ø25	ø32 to ø100
Auto switch model	Auto switch mounting surface Auto switch mounting rail side only	Auto switch mounting surface A/B/C side
D-A9□ D-A9□V D-M9□ D-M9□V D-M9□W D-M9□WV D-M9□AL D-M9□AVL	① BQ-1 ② BQ2-012 Two kinds of auto switch brackets are used as a set.	① BQ-2 ② BQ2-012 Two kinds of auto switch brackets are used as a set.

Note 1) When shipping cylinders, auto switch mounting brackets and auto switches are shipped together.

Auto switch model	Bore size (mm)		
	ø12 to ø25	ø32	ø40 to ø100
D-A7□/A80 D-A73C/A80C D-A7□H/A80H D-A79W D-F7□/J79 D-F7□V D-J79C D-F7□W/J79W D-F7□WV D-F7BAL/F7BAVL D-F79F/F7NTL	BQ-1		BQ-2
D-P4DWL	—		BQP1-050

Note 2) When shipping cylinders, auto switch mounting brackets and auto switches are shipped together. However, when the D-P4DWL type with ø40 to ø100 is mounted the auto switch is assembled at the time of shipment.

Note 3) Refer to pages 1360 to 1362 in Best Pneumatics No. 2 for information on auto switch mounting method.

[Stainless Steel Mounting Screw Kit]

The following stainless steel mounting screw kit (with nuts) is available. Use it in accordance with the operating environment. (Since auto switch spacer (for BQ-2) is not included, order BQ-2 separately.)

BBA2: For D-A7/A8/F7/J7 types

The above stainless steel screws are used when a cylinder is shipped with the D-F7BAL/F7BAVL auto switches.

When only an auto switch is shipped independently, BBA2 is attached. Note 4) Refer to page 1361 in Best Pneumatics No. 2 for details of BBA2.

Note 5) When the D-M9□A(V)L type is mounted, order auto switch mounting brackets BQ2-012S, BQ-2 or the stainless steel mounting screw kit BBA2 separately.

Auto Switch Mounting Bracket/Weight

Mounting bracket part no.	Applicable bore size	Weight (g)
BQ-1	ø12 to ø25	1.5
BQ-2	ø32 to ø100	1.5
BQ2-012	ø12 to ø25	5
BQP1-050	ø40 to ø100	16

- Standard
- Single Acting
- Double Rod
- Axial Piping
- Water Resistant
- High Lateral Load
- End Lock
- Clean Series
- Copper/Fluorine free series
- Construction and Parts
- Warranty and Operating Instructions
- Mounting and Auto Switches
- Made to Order

Other than the applicable auto switches listed in “How to Order”, the following auto switches are mountable. Refer to Best Pneumatics No. 2 for detailed specifications.

Applicable Cylinder Series: CDQP2, CDQP2□□□-□S/-□T (Axial piping)

Auto switch type	Model	Electrical entry	Features	Applicable bore size
Reed	D-A73	Grommet (Perpendicular)	—	ø12 to ø100
	D-A80		Without indicator light	
	D-A73H, A76H	Grommet (In-line)	—	
	D-A80H		Without indicator light	
Solid state	D-F7NV, F7PV, F7BV	Grommet (Perpendicular)	—	ø12 to ø100
	D-F7NWV, F7BWV		Diagnostic indication (2-color indication)	
	D-F7BAVL		Water resistant (2-color indication)	
	D-F79, F7P, J79	Grommet (In-line)	—	
	D-F79W, F7PW, J79W		Diagnostic indication (2-color indication)	
	D-F7BAL		Water resistant (2-color indication)	
	D-F7NTL	Grommet (In-line)	With timer	ø40 to ø100
	D-P5DWL		Magnetic field resistant (2-color indication)	

- * With pre-wired connector is also available for solid state auto switches. For details, refer to Best Pneumatics No. 2.
- * Normally closed (NC = b contact) solid state auto switches (D-F9G/F9H) are also available. For details, refer to Best Pneumatics No. 2.
- * When using a magnetic field resistant solid state auto switch D-P3DW□ type, please contact SMC separately. (Applicable bore size: ø32 to ø100)
- * Heat resistant solid state auto switch (D-F7NJL) is not applicable.
- * Regarding the D-P5DWL, please contact SMC separately.

Applicable Auto Switches

With End Lock

Type	Special function	Electrical entry	Indicator light	Wiring (Output)	Load voltage		Auto switch model				Lead wire length (m)					Pre-wired connector	Applicable load					
					DC	AC	Perpendicular		In-line		0.5 (Nil)	1 (M)	3 (L)	5 (Z)	None (N)							
							ø20, ø25	ø32 to ø100	ø20, ø25	ø32 to ø100												
Solid state auto switch	—	Grommet	No	3-wire (NPN)	24 V	—	5 V, 12 V	M9NV	M9N	●	●	●	○	—	○	IC circuit	Relay, PLC					
				3-wire (PNP)						●	●	●	○	—	○							
		2-wire		●						●	●	○	—	○	—							
		— J79C		—						—	—	—	—	—								
	Diagnostic indication (2-color indication)	Grommet	Yes	3-wire (NPN)	24 V	—	5 V, 12 V	M9NVV	M9NV	●	●	●	○	—	○	IC circuit						
				3-wire (PNP)						●	●	●	○	—	○							
		2-wire		●						●	●	○	—	○	—							
		—		—						—	—	—	—	—								
	Water resistant (2-color indication)	Grommet	No	3-wire (NPN)	24 V	—	5 V, 12 V	M9NAV**	M9NA**	○	○	●	○	—	○	IC circuit						
				3-wire (PNP)						○	○	●	○	—	○							
	2-wire	Grommet	No	2-wire	24 V	—	12 V	M9BAV**	M9BA**	○	○	●	○	—	○	—						
				—						—	—	—	—	—	—							
With diagnostic output (2-color indication)	Grommet	No	4-wire	24 V	—	5 V, 12 V	—	F79F	●	—	●	○	—	○	IC circuit							
			—						—	—	—	—	—	—								
Magnetic field resistant (2-color indication)	Grommet	No	2-wire (Non-polar)	24 V	—	—	—	P4DW	—	—	●	●	—	○	—							
			—						—	—	—	—	—	—								
Reed auto switch	—	Grommet	Yes	3-wire (NPN equivalent)	24 V	—	5 V, 12 V	A96V	A96	●	—	●	—	—	—	IC circuit	Relay, PLC					
				—						200 V	—	A72	—	A72H	●			—	●	—	—	—
				12 V						100 V	—	A93V	—	A93	●			—	●	—	—	—
		Connector	No	5 V, 12 V						100 V or less	—	A90V	—	A90	●	—		●	—	—	—	IC circuit
				12 V						—	—	A73C	—	—	●	—		●	●	—	—	
				5 V, 12 V						24 V or less	—	A80C	—	—	●	—		●	●	—	—	
Diagnostic indication (2-color indication)	Grommet	Yes	—	24 V	—	—	—	A79W	—	●	—	●	—	—	—	—						
			—							—	—	—	—	—	—							

* * Water resistant type auto switches can be mounted on the above models, but in such case SMC cannot guarantee water resistance. Consult with SMC regarding water resistant types with the above model numbers.

* Lead wire length symbols: 0.5 m Nil (Example) M9NW
 1 m M (Example) M9NWM
 3 m L (Example) M9NWL
 5 m Z (Example) M9NWZ
 None N (Example) J79CN

* Solid state auto switches marked with "○" are produced upon receipt of order.
 * The D-P4DWL type is available from ø40 to ø100 only.
 * Only for the D-P4DWL type, an auto switch is assembled and shipped with the cylinder.

* There are other applicable auto switches other than the listed above. For details, refer to page 206.
 * For details about auto switches with pre-wired connector, refer to pages 1328 and 1329 in Best Pneumatics No. 2.
 * When the D-A9□(V)/M9□(V)/M9□W(V)/M9□A(V)L types with ø32 to ø50 are mounted on a surface other than the port side, order auto switch mounting brackets separately. Refer to page 205 for details.

Standard

Single Acting

Double Rod

Axial Piping

Water Resistant

High Lateral Load

End Lock

Clean Series

Copper/Fluorine free series

Construction and Parts

Warranty and Operating Instructions

Mounting and Auto Switches

Made to Order

1 Auto Switch Proper Mounting Position (Detection at Stroke End) and Mounting Height

Applicable Cylinder Series: CDBQ2 (With end lock)

- D-A9□
- D-M9□
- D-M9□W
- D-M9□AL
- D-A9□V
- D-M9□V
- D-M9□WV
- D-M9□AVL

∅20, ∅25

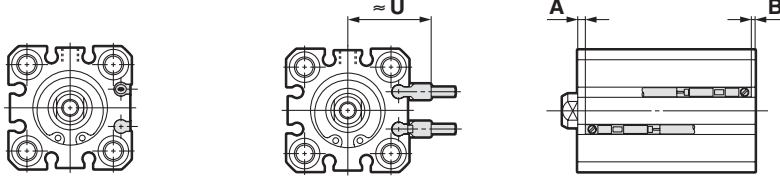

∅32 to ∅100

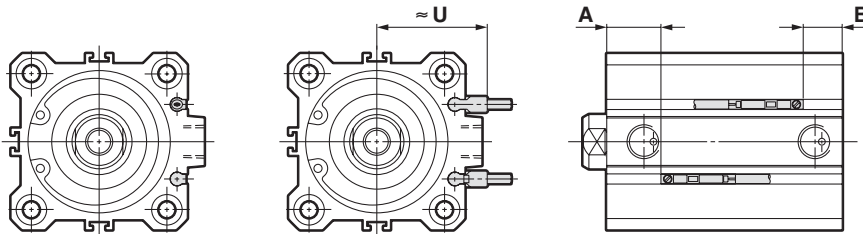

- D-A7□
- D-A80
- D-A7□H
- D-A80H
- D-F7□
- D-J79
- D-F7□W
- D-J79W
- D-F79F
- D-F7NTL
- D-F7BAL
- D-A73C
- D-A80C
- D-J79C
- D-A79W
- D-F7□WV
- D-F7□V
- D-F7BAVL

∅32 to ∅100

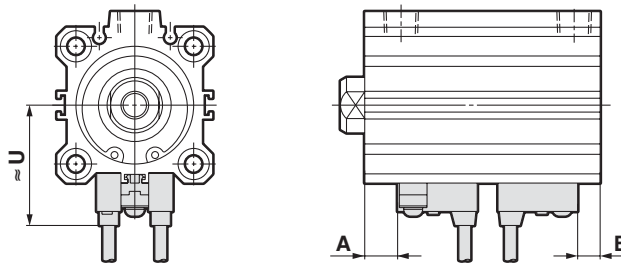

D-P4DWL

∅40 to ∅100

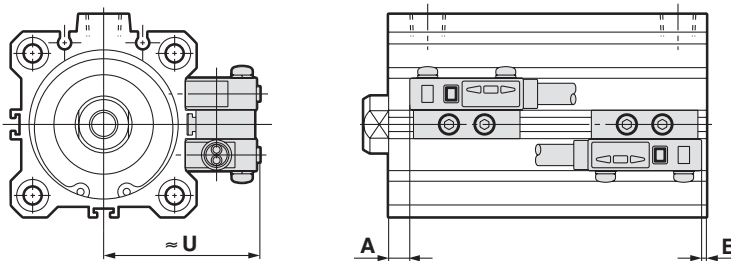

Auto Switch Mounting Height

Applicable Cylinder Series: CDBQ2 (With end lock)

(mm)

Auto switch model Bore size	D-A7□ D-A80		D-A7□H/A80H D-A73C/A80C D-F7□/J79/J79W D-F7□V/J79C D-F7□W/F7□WV D-F7BAL/F7BAVL D-F79F/F7NTL		D-A79W		D-A9□ D-A9□V		D-M9□ D-M9□V D-M9□W D-M9□WV D-M9□AL D-M9□AVL		D-P4DWL	
	A	B	A	B	A	B	A	B	A	B	A	B
20 (Head end lock)	—	—	—	—	—	—	6 (11)	35 (35)	10 (15)	39 (39)	—	—
20 (Rod end lock)	—	—	—	—	—	—	31.5 (34)	3 (12)	35.5 (38)	7 (16)	—	—
25 (Head end lock)	—	—	—	—	—	—	8 (10)	37 (39)	12 (14)	41 (43)	—	—
25 (Rod end lock)	—	—	—	—	—	—	32 (35)	5.5 (14)	36 (39)	9.5 (18)	—	—
32 (Head end lock)	9	38.5	9.5	39	6.5	36	8	37.5	12	41.5	—	—
32 (Rod end lock)	36	4	36.5	4.5	33.5	1.5	35	3	39	7	—	—
40 (Head end lock)	13	44	13.5	44.5	10.5	41.5	12	43	16	47	9	40
40 (Rod end lock)	42	4.5	42.5	5	39.5	2	41	3.5	45	7.5	38	0.5
50 (Head end lock)	11	46.5	11.5	47	8.5	44	10	45.5	14	49.5	7	42.5
50 (Rod end lock)	41.5	6	42	6.5	39	3.5	40.5	5	44.5	9	37.5	2
63 (Head end lock)	13.5	45.5	14	46	11	43	12.5	44.5	16.5	48.5	9.5	41.5
63 (Rod end lock)	45.5	7.5	46	8	43	5	44.5	6.5	48.5	10.5	41.5	3.5
80 (Head end lock)	16.5 (21.5)	76.5 (76.5)	17 (22)	77 (77)	14 (19)	74 (74)	15.5 (20.5)	75.5 (75.5)	19.5 (24.5)	79.5 (79.5)	12.5 (17.5)	72.5 (72.5)
80 (Rod end lock)	66.5 (66.5)	19 (31.5)	67 (67)	19.5 (32)	64 (64)	16.5 (29)	65.5 (65.5)	18 (30.5)	69.5 (69.5)	22 (34.5)	62.5 (62.5)	15 (27.5)
100 (Head end lock)	21 (26)	81.5 (81.5)	21.5 (26.5)	82 (82)	18.5 (23.5)	79 (79)	20 (25)	80.5 (80.5)	24 (29)	84.5 (84.5)	17 (22)	77.5 (77.5)
100 (Rod end lock)	71 (69.5)	24 (38)	71.5 (70)	24.5 (38.5)	68.5 (67)	21.5 (35.5)	70 (68.5)	23 (37)	74 (72.5)	27 (41)	67 (65.5)	20 (34)

Note) The dimensions in parentheses for ø20 and ø25 are for 50, 75 and 100 mm strokes, and the dimensions in parentheses for ø80 and ø100 are for 75 and 100mm strokes. Adjust the auto switch after confirming the operating conditions in the actual setting.

Applicable Cylinder Series: CDBQ2 (With end lock)

(mm)

Auto switch model Bore size	D-A7□ D-A80	D-A7□H D-A80H/J79W D-F7□/F7BAL D-J79/F79F D-F7□W/F7NTL	D-A73C D-A80C	D-F7□V D-F7□WV D-F7BAVL	D-J79C	D-A79W	D-A9□V	D-M9□V D-M9□WV D-M9□AVL	D-P4DWL
	U	U	U	U	U	U	U	U	U
20	—	—	—	—	—	—	22.5	24.5	—
25	—	—	—	—	—	—	24.5	26.5	—
32	31.5	32.5	38.5	35	38	34	27	29	—
40	35	36	42	38.5	41.5	37.5	30.5	32.5	44
50	41	42	48	44.5	47.5	43.5	36.5	38.5	50
63	47.5	48.5	54.5	51	54	50	40	42	56.5
80	57.5	58.5	64.5	61	64	60	50	52	66.5
100	67.5	68.5	74.5	71	74	70	60	62	76.5

- Standard
- Single Acting
- Double Rod
- Axial Piping
- Water Resistant
- High Lateral Load
- End Lock
- Clean Series
- Copper/Fluorine free series
- Construction and Parts
- Warranty and Operating Instructions
- Mounting and Auto Switches
- Made to Order

2 Minimum Stroke for Auto Switch Mounting

Applicable Cylinder Series: CDBQ2 (With end lock)

(mm)

Number of auto switches	D-M9□V D-F7□V D-J79C	D-A9□V D-A7□ D-A80 D-A73C D-A80C	D-A9□	D-M9□WV D-M9□AVL D-F7□WV D-F7BAVL	D-M9□ D-M9□W D-M9□AL D-A7□H D-A80H D-F7□ D-J79	D-A79W	D-F7□W D-J79W D-F7BAL D-F79F D-F7NTL	D-P4DWL
With 1 pc.	5	5	10	10	15	15	20	15
With 2 pcs.	5	10	10	15	15	20	20	15

3 Operating Range

Applicable Cylinder Series: CDBQ2 (With end lock)

(mm)

Auto switch model	Bore size							
	20	25	32	40	50	63	80	100
D-A9□(V)	10	10	9.5 (9.5)	9.5 (9.5)	9.5 (8.5)	11.5 (11)	9 (10)	11.5 (10.5)
D-M9□(V) D-M9□W(V) D-M9□A(V)L	5.5	5.5	6 (5.5)	6 (5.5)	7 (6)	7.5 (6.5)	8 (7)	8.5 (7)
D-A7□(H)(C) D-A80□(H)(C)	—	—	12	11	10	12	12	13
D-A79W	—	—	13	14	14	16	15	17
D-F7□(V) D-J79(C) D-F7□W(V) D-F7BA(V)L D-F7NTL D-F79F	—	—	6	6	6	6.5	6.5	7
D-P4DWL	—	—	—	5	5	5	5	5.5

- * Values which include hysteresis are for guideline purposes only, they are not a guarantee (assuming approximately ±30% dispersion) and may change substantially depending on the ambient environment.
- * The values for ø32 or more of the D-A9□(V)/M9□(V)/M9□W(V)/M9□A(V)L types indicate the operating range when the conventional switch installation groove is attached without using the auto switch mounting bracket BQ2-012.
- * The values in parentheses for ø32 or more of the D-A9□(V)/M9□(V)/M9□W(V)/M9□A(V)L types indicate the operating range when the auto switch mounting bracket BQ2-012 is used.

4 Auto Switch Mounting Mounting Brackets/Part Number

Applicable Cylinder Series: CDBQ2 (With end lock)

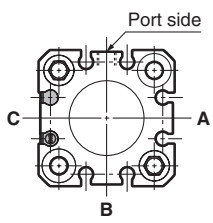
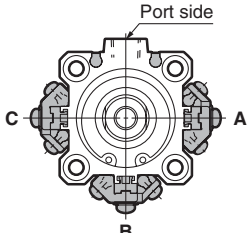
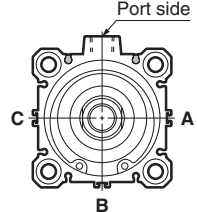
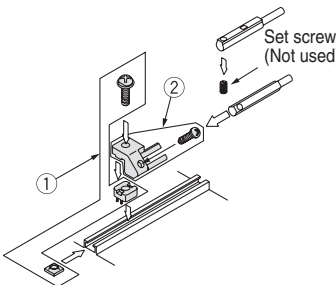
Auto switch mounting surface	Bore size (mm)		
	ø20, ø25	ø32, ø40, ø50	ø63, ø80, ø100
			
Auto switch model	Port/A/B/C side	Port side	A/B/C side
D-A9□ D-A9□V D-M9□ D-M9□V D-M9□W D-M9□WV D-M9□AL D-M9□AVL	Auto switch mounting brackets are not required.	Auto switch mounting brackets are not required.	① BQ-2 ② BQ2-012 Two kinds of auto switch brackets are used as a set. 

Note 1) When a compact auto switch is mounted on the three sides (A, B and C above) other than the port side of ø32 to ø50 cylinders, auto switch mounting brackets shown above are required. Order them separately from cylinders.

(The above is also applicable when a compact auto switch is mounted using an auto switch mounting rail, but not using a compact auto switch installation groove for ø63 to ø100 cylinders.)

Ordering example

CDBQ2B32-50D-M9BW.....1 pc.

BQ-2.....2 pcs.

BQ2-012.....2 pcs.

Note 2) When shipping cylinders, auto switch mounting brackets and auto switches are shipped together.

Auto switch model	Bore size (mm)					
	32	40	50	63	80	100
D-A7□/A80 D-A73C/A80C D-A7□H/A80H D-A79W D-F7□/J79 D-F7□V D-J79C D-F7□W/J79W D-F7□WV D-F7BAL/F7BAVL D-F79F/F7NTL						BQ-2
D-P4DWL	—					BQP1-050

Note 3) When shipping cylinders, auto switch mounting brackets and auto switches are shipped together.

Note 4) Refer to pages 1360 to 1362 in Best Pneumatics No. 2 for further information on auto switch mounting method.

[Stainless Steel Mounting Screw Kit]

The following stainless steel mounting screw kit (with nuts) is available. Use it in accordance with the operating environment. (Since auto switch spacer (for BQ-2) is not included, order BQ-2 separately.)

BBA2: For D-A7/A8/F7/J7 types

The above stainless steel mounting screws are used when a cylinder is shipped with the D-F7BAL/F7BAVL auto switches.

When only an auto switch is shipped independently, BBA2 is attached.

Note 5) Refer to page 1361 in Best Pneumatics No. 2 for details of BBA2.

Note 6) When the D-M9□A(V)L type is mounted on a port size other than ø32, ø40 or ø50, order auto switch mounting brackets BQ2-012S, BQ-2 or the stainless steel mounting screw kit BBA2 separately.

Auto Switch Mounting Bracket/Weight

Mounting bracket part no.	Weight (g)
BQ-2	1.5
BQ2-012	5
BQP1-050	16

- Standard
- Single Acting
- Double Rod
- Axial Piping
- Water Resistant
- High Lateral Load
- End Lock
- Clean Series
- Copper/Fluorine free series
- Construction and Parts
- Warranty and Operating Instructions
- Mounting and Auto Switches
- Made to Order

Series CDBQ2 With End Lock
With Auto Switch 3

Other than the applicable auto switches listed in “How to Order”, the following auto switches are mountable. Refer to Best Pneumatics No. 2 for detailed specifications.

Applicable Cylinder Series: CDBQ2 (With end lock)

Auto switch type	Model	Electrical entry	Features	Applicable bore size
Reed	D-A73	Grommet (Perpendicular)	—	ø32 to ø100
	D-A80		Without indicator light	
	D-A73H, A76H	Grommet (In-line)	—	
	D-A80H		Without indicator light	
Solid state	D-F7NV, F7PV, F7BV	Grommet (Perpendicular)	—	ø32 to ø100
	D-F7NWV, F7BWV		Diagnostic indication (2-color indication)	
	D-F7BAVL		Water resistant (2-color indication)	
	D-F79, F7P, J79	Grommet (In-line)	—	
	D-F79W, F7PW, J79W		Diagnostic indication (2-color indication)	
	D-F7BAL		Water resistant (2-color indication)	
	D-F7NTL		With timer	
	D-P5DWL	Grommet (In-line)	Magnetic field resistant (2-color indication)	

- * With pre-wired connector is also available for solid state auto switches. For details, refer to Best Pneumatics No. 2.
- * Normally closed (NC = b contact) solid state auto switches (D-F9G/F9H) are also available. For details, refer to Best Pneumatics No. 2.
- * When using a magnetic field resistant solid state auto switch D-P3DW□ type, please contact SMC separately. (Applicable bore size: ø32 to ø100)
- * Heat resistant solid state auto switch (D-F7NJL) is not applicable.
- * Regarding the D-P5DWL, please contact SMC separately.

⚠ Specific Product Precautions

Refer to Best Pneumatics for Auto Switch Precautions before using auto switches.

Auto Switches Common Specifications

Type	Reed auto switch	Solid state auto switch
Leakage current	None	3-wire: 100 μ A or less, 2-wire: 0.8 mA or less
Operating time	1.2 ms	1 ms or less ⁽³⁾
Impact resistance	300 m/s ²	1000 m/s ²
Insulation resistance	50 M Ω or more at 500 VDC Mega (Between lead wire and case)	
Withstand voltage	1500 VAC for 1 minute ⁽¹⁾ (Between lead wire and case)	1000 VAC for 1 minute (Between lead wire and case)
Ambient temperature	-10 to 60°C	
Enclosure	IEC60529 Standard IP67 ⁽²⁾	

- * 1) Electrical entry: Connector type (A73C/A80C/C73C/C80C): 1000 VAC/min. (Between lead wire and the case)
- * 2) The terminal conduit type (D-A3/G39/K39), DIN terminal type (D-A44) and conform to IEC60529 Standard IP63.
- * 3) Excluding the solid state autoswitches with a timer (G5NNTL/F7NNTL/F5NNTL types) for D-J51 is 2 ms or less.

Lead Wire

Lead wire length indication (Example)

D-M9BW**L**

● Lead wire length

Nil	0.5 m
M	1 m
L	3 m
Z	5 m
N*	None

* Applicable for the connector type (D-□□C) only.

Note 1) Lead wire length Z: 5 m

Applicable auto switches

Reed auto switch: D-B53/B54, D-C73(C)/C80C, D-A73(C)(H)/A80C, D-A53/A54, D-Z73

Solid state auto switch:

Manufactured upon receipt of order as standard.

Note 2) The standard lead wire length for solid state auto switches with timer, switches is 3m. (0.5m is not available.)

Note 3) 1 m (M): D-M9□(W)(V) only

Note 4) Lead wire length tolerance

Lead wire length	Tolerance
0.5 m	±15 mm
1 m	±30 mm
3 m	±90 mm
5 m	±150 mm

Solid state auto switch oil resistant flexible cable cord indication

Add -61 at end of the part number for the solid state auto switch flexible cord except D-Y59□, D-Y69□, D-Y7□, D-M9□/M9□V, and D-M9□W/M9□WV.

(Example)

D-F7PL-61

● Flexible specification

(D-Y59, D-Y69, D-Y7 and D-M9 series use flexible lead wire as standard.)

Lead wires with a connector indication

Part No. of Lead Wires with Connectors

(Applicable only for connector type)

Model	Lead wire length
D-LC05	0.5 m
D-LC30	3 m
D-LC50	5 m

Standard

Single Acting

Double Rod

Axial Piping

Water Resistant

High Lateral Load

End Lock

Clean Series

Copper/Fluorine free series

Construction and Parts

Warranty and Operating Instructions

Mounting and Auto Switches

Made to Order

Prior to Use

Auto Switches Common Specifications 2

⚠ Specific Product Precautions

Refer to Best Pneumatics for Auto Switch Precautions before using auto switches.

Auto Switch Hysteresis

Hysteresis is the distance between the position at which piston movement operates an auto switch to the position at which reverse movement turns the switch off. This hysteresis is included in part of the operating range (one side).

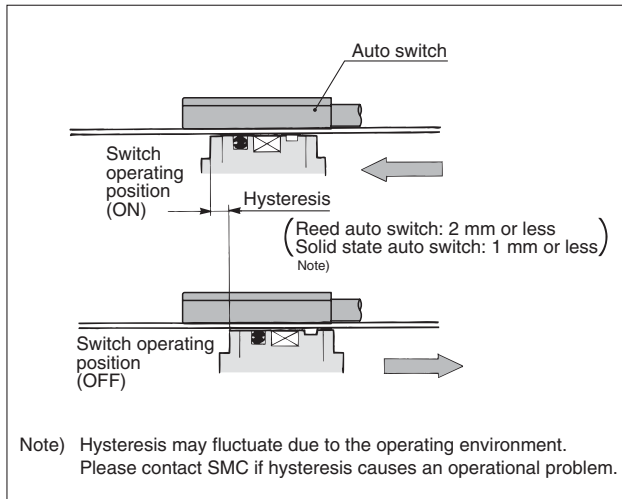

Contact Protection Box Specifications

Part no.	CD-P11	CD-P12
Load voltage	100 VAC or less	200 VAC 24 VDC
Max. load current	25 mA	12.5 mA 50 mA

* Lead wire length — Auto switch connection side 0.5 m
Load connection side 0.5 m

Contact Protection Box Internal Circuit

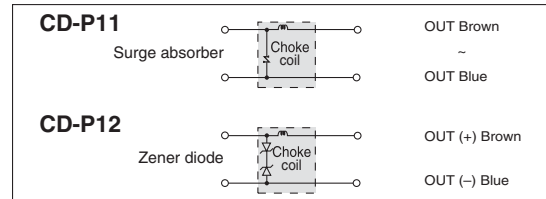

Contact Protection Box/Dimensions

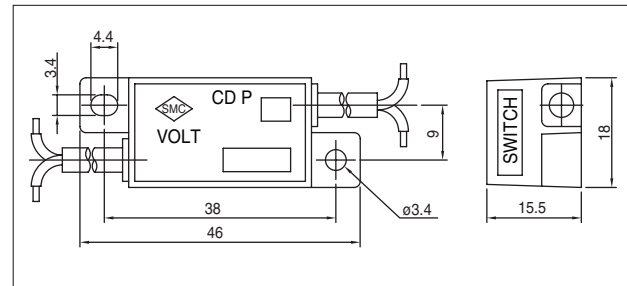

Contact Protection Box: CD-P11, CD-P12

<Applicable switch models>

D-A7/A8, D-A7□H/A80H, D-A73C/A80C, D-C7/C8, D-C73C/C80, D-E7□A, E80A, D-Z7/Z8, D-9/9□A, D-A9/A9□V, and D-A79W type. The auto switches above do not have a built-in contact protection circuit. A contact protection box is not required for solid state auto switches due to their construction.

- ① Where the operation load is an inductive load.
- ② Where the wiring length to load is greater than 5m.
- ③ Where the load voltage is 100/200 VAC.

Therefore, use a contact protection box with the switch for any of the above cases:

The contact life may be shortened (due to permanent energizing conditions.)

D-A72(H) must be used with the contact protection box regardless of load types and lead wire length since it is greatly affected by loads.

(Where the load voltage is 110 VAC)

When the load voltage is increased by more than 10% to the rating of applicable auto switches (except D-A73C/A80C/C73C/C80C/90/97/ A79W) above, use a contact protection box (CD-P11) to reduce the upper limit of the load current by 10% so that it can be set within the load current range, 110 VAC.

Even for the built-in contact protection circuit type (D-A34[A][C], D-A44[A][C], D-A54/A64, D-A59W, D-B59W), use the contact protection box when the wiring length to load is very long (over 30 m) and PLC (Programmable Logic Controller) with a large inrush current is used.

Contact Protection Box/Connection

To connect a switch unit to a contact protection box, connect the lead wire from the side of the contact protection box marked SWITCH to the lead wire coming out of the switch unit. Keep the switch as close as possible to the contact protection box, with a lead wire length of no more than 1 meter.

Basic Wiring

Solid state 3-wire, NPN

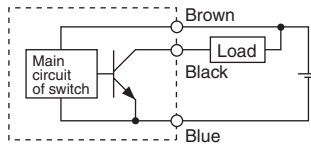

Solid state 3-wire, PNP

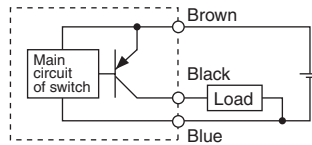

2-wire (Solid state)

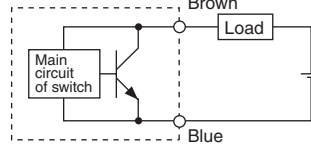

2-wire (Reed)

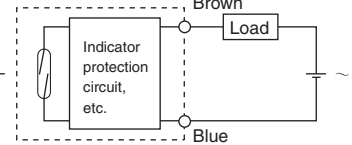

(Power supply for switch and load are separate.)

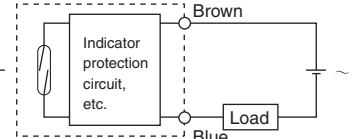
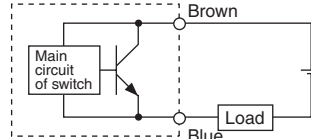
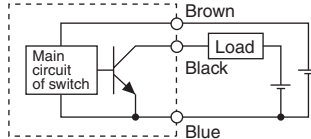

Example of Connection with PLC (Programmable Logic Controller)

• Sink input specifications 3-wire, NPN

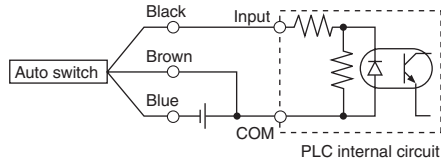

• Source input specifications 3-wire, PNP

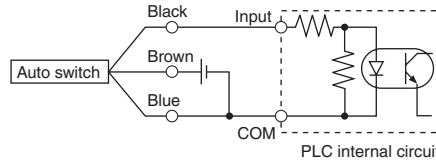

Connect according to the applicable PLC input specifications, as the connection method will vary depending on the PLC input specifications.

2-wire

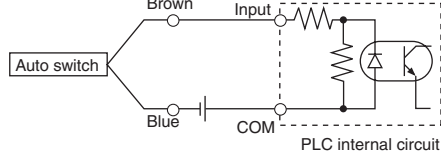

2-wire

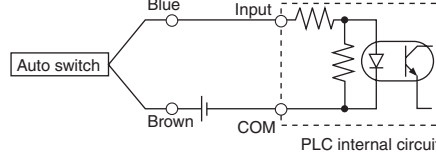

Example of AND (Series) and OR (Parallel) Connection

• 3-wire

AND connection for NPN output (Using relays)

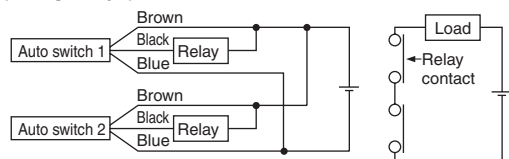

AND connection for NPN output (Performed with auto switches only)

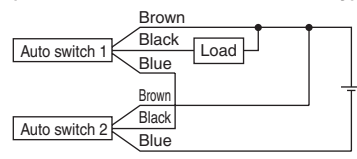

OR connection for NPN output

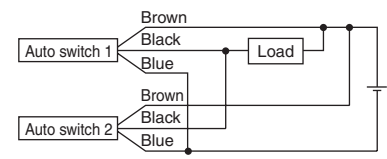

The indicator lights will light up when both of the auto switches are in the ON state.

• 2-wire

2-wire with 2-switch AND connection

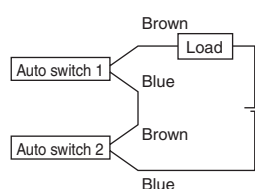

When two auto switches are connected in series, malfunction may occur because the load voltage will decrease in the ON state. The indicator lights will light up when both of the auto switches are in the ON state.

$$\begin{aligned} \text{Load voltage at ON} &= \text{Power supply voltage} - \text{Residual voltage} \times 2 \text{ pcs.} \\ &= 24 \text{ V} - 4 \text{ V} \times 2 \text{ pcs.} \\ &= 16 \text{ V} \end{aligned}$$

Example: Power supply voltage 24 VDC
Auto switch internal voltage drop 4 V

2-wire with 2-switch OR connection

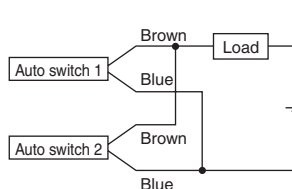

(Solid state)
When two auto switches are connected in parallel, malfunction may occur because the load voltage will increase in the OFF state.

(Reed)
Because there is no leakage current, the load voltage will not increase in the OFF state. However, depending on the number of auto switches in the ON state, the indicator lights may sometimes glow dim or not light up, due to the dispersion and reduction of the current flowing to the auto switches.

$$\begin{aligned} \text{Load voltage at OFF} &= \text{Leakage current} \times 2 \text{ pcs.} \times \text{Load impedance} \\ &= 1 \text{ mA} \times 2 \text{ pcs.} \times 3 \text{ k}\Omega \\ &= 6 \text{ V} \end{aligned}$$

Example: Load impedance 3 k Ω
Auto switch leakage current 1 mA

Standard

Single Acting

Double Rod

Axial Piping

Water Resistant

High Lateral Load

End Lock

Clean Series

Copper/Fluorine free series

Construction and Parts

Warranty and Operating Instructions

Mounting and Auto Switches

Made to Order

D-M9N(V) / D-M9P(V) / D-M9B(V)

Solid State Auto Switch - Direct Mounting Style



Grommet

- 2-wire load current is reduced (2.5 to 40 mA).
- Flexibility is 1.5 times greater than the conventional model (SMC comparison).
- Using flexible cable as standard spec.



Caution

Precautions

Do not fix the auto switch with screws other than the existing screw installed on the auto switch body. The auto switch may be damaged if a screw other than the one supplied is used.

Auto Switch Internal Circuit

D-M9N, D-M9NV

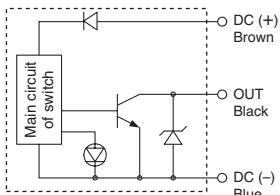

D-M9P, D-M9PV

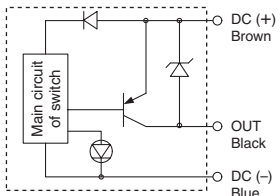

D-M9B, D-M9BV

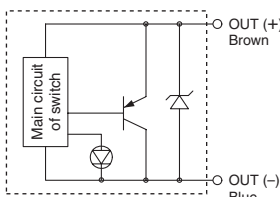

Auto Switches Specifications

Refer to SMC website for details of products conforming to international standards.

PLC: Programmable Logic Controller

D-M9□, D-M9□V (With indicator light)						
Auto switch model	D-M9N	D-M9NV	D-M9P	D-M9PV	D-M9B	D-M9BV
Electrical entry direction	In-line	Perpendicular	In-line	Perpendicular	In-line	Perpendicular
Wiring type	3-wire				2-wire	
Output type	NPN		PNP		—	
Applicable load	IC circuit, Relay, PLC				24 VDC relay, PLC	
Power supply voltage	5, 12, 24 VDC (4.5 to 28 V)				—	
Current consumption	10 mA or less				—	
Load voltage	28 VDC or less		—		24 VDC (10 to 28 VDC)	
Load current	40 mA or less				2.5 to 40 mA	
Internal voltage drop	0.8 V or less at 10 mA (2 V or less at 40 mA)				4 V or less	
Leakage current	100 μA or less at 24 VDC				0.8 mA or less	
Indicator light	Red LED illuminates when turned ON.					
Standard	CE marking					

• Lead wires — Oilproof flexible heavy-duty vinyl cord: $\phi 2.7 \times 3.2$ ellipse, 0.15 mm², 2 cores (D-M9B(V)), 3 cores (D-M9N(V), D-M9P(V))

Note 1) Refer to page 207 for solid state auto switch common specifications.

Note 2) Refer to page 207 for lead wire lengths.

Mass

(g)

Auto switch model		D-M9N(V)	D-M9P(V)	D-M9B(V)
Lead wire length (m)	0.5	8	8	7
	1	14	14	13
	3	41	41	38
	5	68	68	63

Dimensions

(mm)

D-M9□

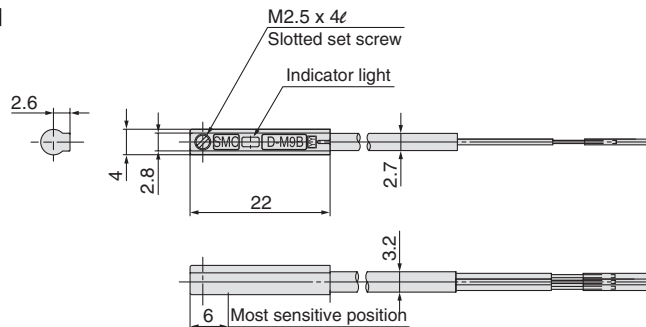

D-M9□V

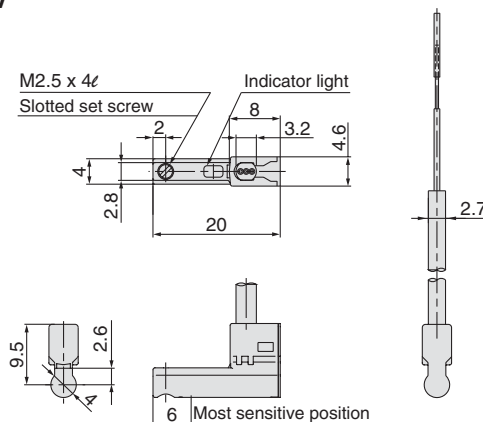

D-M9NW(V) / D-M9PW(V) / D-M9BW(V)

2-Color Indication Type Solid State Auto Switch - Direct Mounting Style



Grommet

- 2-wire load current is reduced (2.5 to 40 mA).
- Flexibility is 1.5 times greater than the conventional model (SMC comparison).
- Using flexible cable as standard spec.
- The optimum operating position can be determined by the color of the light. (Red → Green ← Red)



Caution

Precautions

Do not fix the auto switch with screws other than the existing screw installed on the auto switch body. The auto switch may be damaged if a screw other than the one supplied is used.

Auto Switch Internal Circuit

D-M9NW, D-M9NWV

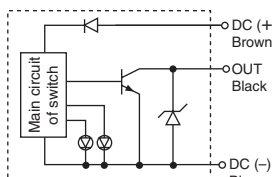

D-M9PW, D-M9PWV

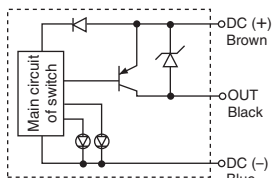

D-M9BW, D-M9BWV

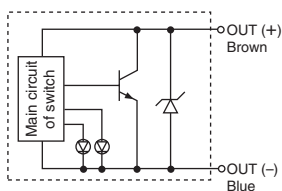

Indicator light / Display method

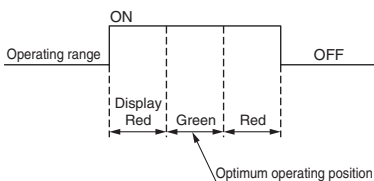

Auto Switches Specifications

Refer to SMC website for details of products conforming to international standards.

PLC: Programmable Logic Controller

D-M9□W, D-M9□WV (With indicator light)						
Auto switch model	D-M9NW	D-M9NWV	D-M9PW	D-M9PWV	D-M9BW	D-M9BWV
Electrical entry direction	In-line	Perpendicular	In-line	Perpendicular	In-line	Perpendicular
Wiring type	3-wire				2-wire	
Output type	NPN		PNP		—	
Applicable load	IC circuit, Relay, PLC				24 VDC relay, PLC	
Power supply voltage	5, 12, 24 VDC (4.5 to 28 V)				—	
Current consumption	10 mA or less				—	
Load voltage	28 VDC or less		—		24 VDC (10 to 28 VDC)	
Load current	40 mA or less				2.5 to 40 mA	
Internal voltage drop	0.8 V or less at 10 mA (2 V or less at 40 mA)				4 V or less	
Leakage current	100 μA or less at 24 VDC				0.8 mA or less	
Indicator light	Operating position Red LED illuminates. Optimum operating position Green LED illuminates.					
Standard	CE marking					

- Lead wires - Oilproof flexible heavy-duty vinyl cord: $\phi 2.7 \times 3.2$ ellipse, 0.15 mm², 2 cores (D-M9BW(V)), 3 cores (D-M9NW(V), D-M9PW(V))

Note 1) Refer to page 207 for solid state auto switch common specifications.

Note 2) Refer to page 207 for lead wire lengths.

Mass

(g)

Auto switch model		D-M9NW(V)	D-M9PW(V)	D-M9BW(V)
Lead wire length (m)	0.5	8	8	7
	1	14	14	13
	3	41	41	38
	5	68	68	63

Dimensions

(mm)

D-M9□W

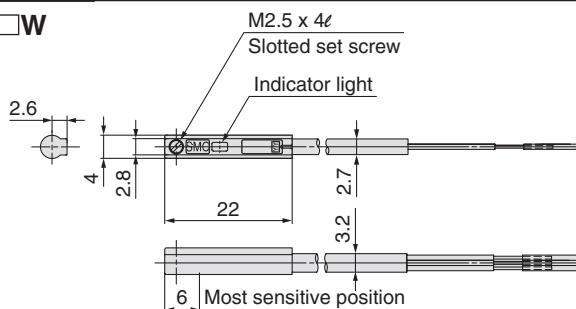

D-M9□WV

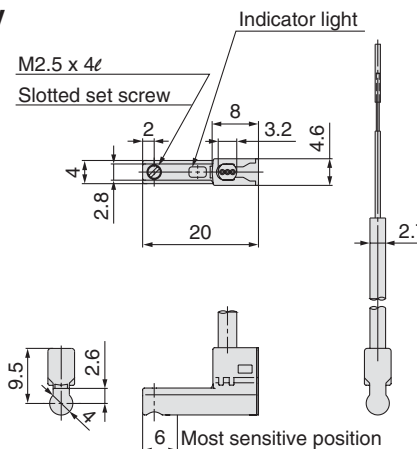

- Standard
- Single Acting
- Double Rod
- Axial Piping
- Water Resistant
- High Lateral Load
- End Lock
- Clean Series
- Copper/Fluorine free series
- Construction and Parts
- Warranty and Operating Instructions
- Mounting and Auto Switches
- Made to Order

D-M9NA(V) / D-M9PA(V) / D-M9BA(V)

Water Resistant 2-Color Indication Type Solid State Auto Switch - Direct Mounting Style



Grommet

- Water (coolant) resistant type
- 2-wire load current is reduced (2.5 to 40 mA).
- The optimum operating position can be determined by the color of the light. (Red → Green ← Red)
- Using flexible cable as standard spec.



Caution

Precautions

Do not fix the auto switch with screws other than the existing screw installed on the auto switch body. The auto switch may be damaged if a screw other than the one supplied is used.

Auto Switch Internal Circuit

D-M9NA, D-M9NAV

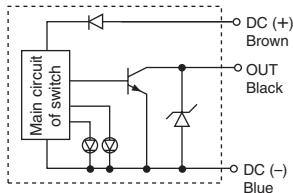

D-M9PA, D-M9PAV

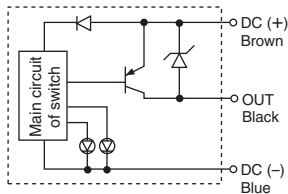

D-M9BA, D-M9BAV

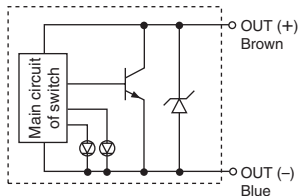

Indicator light/Display method

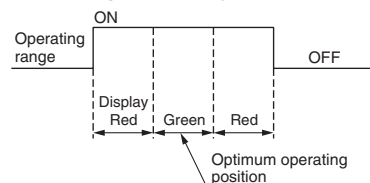

Auto Switch Specifications

Refer to SMC website for details of products conforming to international standards.

PLC: Programmable Logic Controller

D-M9□A, D-M9□AV (With indicator light)						
Auto switch model	D-M9NA	D-M9NAV	D-M9PA	D-M9PAV	D-M9BA	D-M9BAV
Electrical entry direction	In-line	Perpendicular	In-line	Perpendicular	In-line	Perpendicular
Wiring type	3-wire				2-wire	
Output type	NPN		PNP		—	
Applicable load	IC circuit, Relay, PLC				24 VDC relay, PLC	
Power supply voltage	5, 12, 24 VDC (4.5 to 28 V)				—	
Current consumption	10 mA or less				—	
Load voltage	28 VDC or less		—		24 VDC (10 to 28 VDC)	
Load current	40 mA or less				2.5 to 40 mA	
Internal voltage drop	0.8 V or less at 10 mA (2 V or less at 40 mA)				4 V or less	
Leakage current	100 μA or less at 24 VDC				0.8 mA or less	
Indicator light	Operating position Red LED illuminates. Optimum operating position Green LED illuminates.					
Standard	CE marking					

- Lead wires - Oilproof flexible heavy-duty vinyl cord: $\phi 2.7 \times 3.2$ ellipse, 0.15 mm², 2 cores (D-M9BA(V)), 3 cores (D-M9NA(V), D-M9PA(V))

Note 1) Refer to page 207 for solid state auto switch common specifications.

Note 2) Refer to page 207 for lead wire lengths.

Mass

(g)

Auto switch model		D-M9NA(V)	D-M9PA(V)	D-M9BA(V)
Lead wire length (m)	0.5	8	8	7
	1	14	14	13
	3	41	41	38
	5	68	68	63

Dimensions

(mm)

D-M9□A

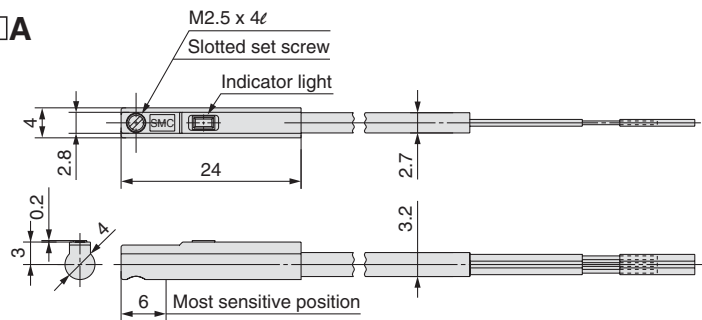

D-M9□AV

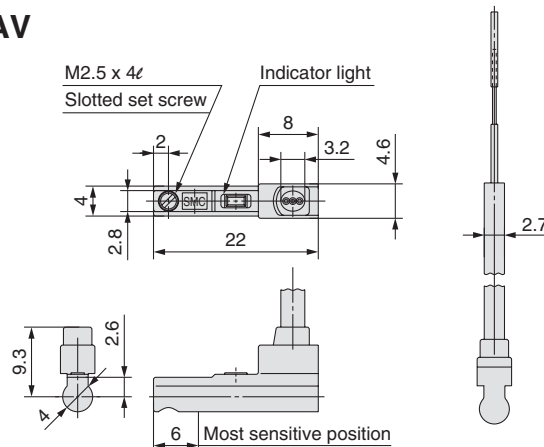

D-M90(V) / D-A93(V) / D-A96(V)

Reed Auto Switch - Direct Mounting Style



Refer to SMC website for details of products conforming to international standards.

Auto Switch Specifications

PLC: Programmable Logic Controller

Grommet

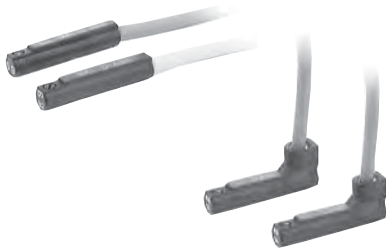

Caution

Precautions

Do not fix the auto switch with screws other than the existing screw installed on the auto switch body. The auto switch may be damaged if a screw other than the one supplied is used.

Auto Switch Internal Circuit

D-A90, A90V

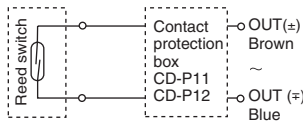

D-A93, A93V

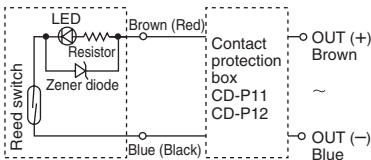

D-A96, A96V

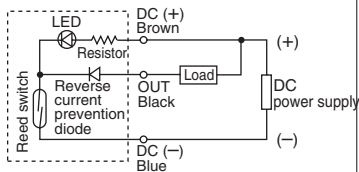

Note 1) Operating load is an induction load.
 Note 2) Wiring to the load is 5m or longer.
 Note 3) Load voltage is 100 VAC.
 Use the contact protection box in any of the above listed situations. The contact point life may decrease. (Refer to page 208 for contact protection box.)

D-A90, D-A90V (Without indicator light)			
Auto switch model	D-A90, D-A90V		
Applicable load	IC circuit, Relay, PLC		
Load voltage	24 V _{AC} or less	48 V _{AC} or less	100 V _{AC} or less
Maximum load current	50 mA	40 mA	20 mA
Contact protection circuit	None		
Internal resistance	1Ω or less (Including lead wire length of 3 m)		
Standard	CE marking		
D-A93, D-A93V, D-A96, D-A96V (With indicator light)			
Auto switch model	D-A90, D-A90V	D-A96, D-A96V	
Applicable load	Relay, PLC		IC circuit
Load voltage	24 VDC	100 VDC	4 to 8 VDC
Load current range and maximum load current ⁽³⁾	5 to 40 mA	5 to 20 mA	20 mA
Contact protection circuit	None		
Internal voltage drop	D-A93: 2.4 V or less (up to 29 mA)/3 V or less (up to 40 mA) D-A93V: 2.7 V or less		0.8 V or less
Indicator light	Red LED illuminates when turned ON.		
Standard	CE marking		

Lead wires

D-A90(V)/D-A93(V)—Oilproof heavy-duty vinyl cord, ø2.7, 0.18 mm² x 2 cores (brown, blue), 0.5m
 D-A96(V)—Oilproof heavy-duty vinyl cord, ø2.7, 0.15 mm² x 3 cores (brown, black, blue), 0.5 m

Note 1) Refer to page 207 for reed auto switch common specifications.

Note 2) Refer to page 207 for lead wire lengths.

Note 3) Under 5 mA, the strength of the indicator light is poor. In some cases, visibility of the indicator light will not be possible where the output signal is less than 2.5 mA. However, there is no problem in terms of contact output, when an output signal exceeds 1 mA or more.

Mass

(g)

Model	D-A90	D-A90V	D-A93	D-A93V	D-A96	D-A96V
Lead wire length (m)	0.5	6	6	6	6	8
	3	30	30	30	30	41

Dimensions

(mm)

D-A90/D-A93/D-A96

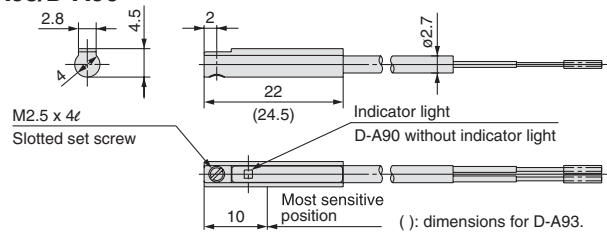

D-A90V/D-A93V/D-A96V

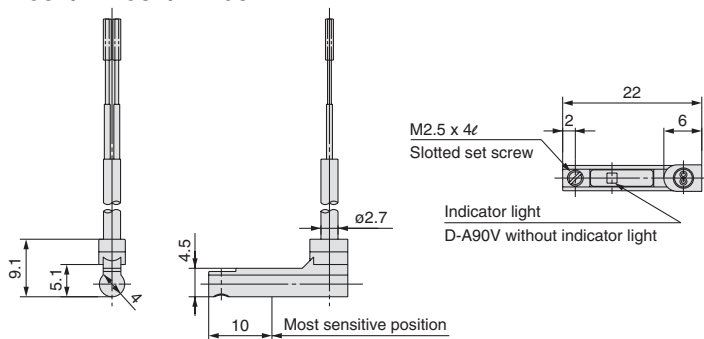

Standard

Single Acting

Double Rod

Axial Piping

Water Resistant

High Lateral Load

End Lock

Clean Series

Copper/Fluorine free series

Construction and Parts

Warranty and Operating Instructions

Mounting and Auto Switches

Made to Order

D-P3DWSC / D-P3DWSW

Magnetic Field Resistant 2-Color Indication Solid State Auto Switch

(Electrical entry: Pre-wired connector)



For details about certified products conforming to international standards, visit us at www.smcworld.com

- It is possible to use in an environment which generates a magnetic field disturbance (AC magnetic field).
- The optimum operating position can be determined by the color of the light. (Red → Green ← Red)



Caution

Precautions

For single-phase AC welding machines If it is used for current inverter welders (including rectifying type) and condenser type welders, the magnetic field resistance is reduced. Please contact SMC regarding the performance.

Auto Switch Specifications

PLC: Programmable Logic Controller

D-P3DWSC/E (With indicator light)		
Auto switch model	D-P3DWSC	D-P3DWSE
Applicable load	24 VDC relay, PLC	
Load voltage	24 VDC (20 to 28 VDC)	
Load current	6 to 40 mA	
Internal voltage drop	5 V or less	
Leakage current	1 mA or less at 24 VDC	
Operating time	40 ms or less	
Indicator light	Operating position.....Red LED illuminates. Optimum operating position.....Green LED illuminates.	
Standards	CE marking, UL (CSA), RoHS	

- Lead wire — Oilproof heavy-duty vinyl cable, $\phi 0.189$, 0.775×10^{-3} in², 2 cores
- Impact resistance — Switch: 39370 in/s², Connector: 11810 in/s²
- Insulation resistance — 50 M Ω or more at 500 VDC Mega (between lead wire and case)
- Withstand voltage — 1000 VAC for 1 minute (between lead wire and case)
- Ambient temperature — 14 to 140°F
- Enclosure — IEC60529 standard IP67
- Polarity: Non-polar

Magnetic Field Resistance

If the current of the AC welding machine is 16000 A or lower, the auto switch can be used, even if the distance between the welding conductor (gun cable) and the cylinder/actuator or auto switch is 0 in. Please contact SMC when the AC welding current exceeds 16000 A.

Mass

Unit: lb(s)

Auto switch model	D-P3DWSC	D-P3DWSE
Lead wire length (in)	11.8	0.051

Dimensions

Unit: in

Body

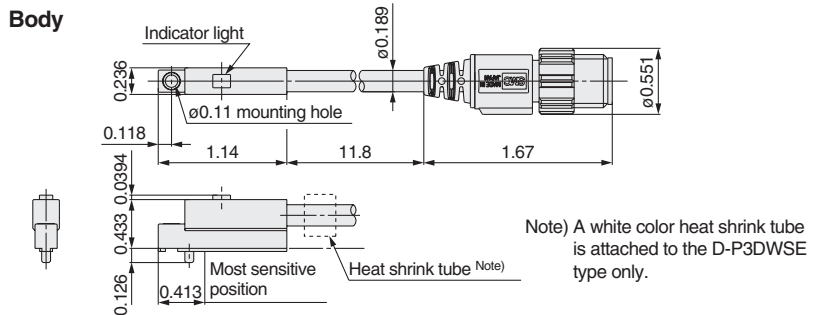

Auto Switch Internal Circuit

D-P3DWSC

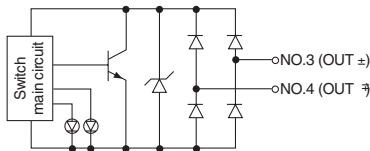

D-P3DWSE

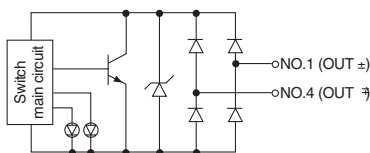

Indicator light/Display method

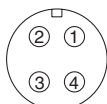
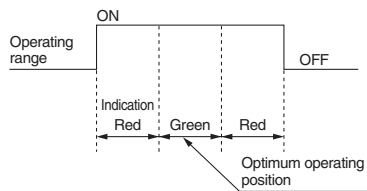

Connector pin assignment

Auto switch mounting bracket (For round groove mounting: BQ3-032S)

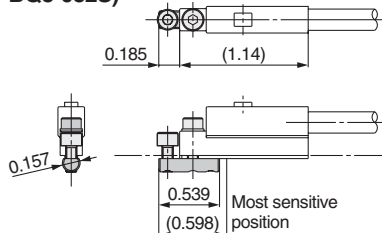

Auto switch mounting bracket (For square groove mounting: BMG5-025S)

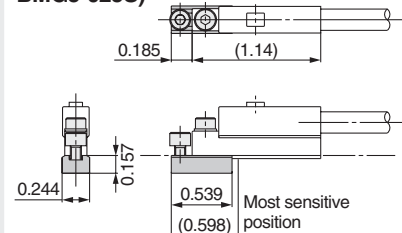

* When the auto switch is ordered on its own, the auto switch mounting bracket is not included. In this case, please order it separately.



Magnetic Field Resistant 2-Color Indication Solid State Auto Switch

(Electrical entry: Grommet)

D-P3DW / L / Z

For details about certified products conforming to international standards, visit us at www.smcworld.com

Auto Switch Specifications

PLC: Programmable Logic Controller

- It is possible to use in an environment which generates a magnetic field disturbance (AC magnetic field).
- The optimum operating position can be determined by the color of the light. (Red → Green ← Red)



D-P3DW/L/Z (With indicator light)	
Auto switch model	D-P3DW/L/Z
Applicable load	24 VDC relay, PLC
Load voltage	24 VDC (20 to 28 VDC)
Load current	6 to 40 mA
Internal voltage drop	5 V or less
Leakage current	1 mA or less at 24 VDC
Operating time	40 ms or less
Indicator light	Operating position.....Red LED illuminates. Optimum operating position.....Green LED illuminates.
Standards	CE marking, UL (CSA), RoHS

- Lead wire — Oilproof heavy-duty vinyl cable, $\phi 0.189$, 0.775×10^{-3} in², 2 cores, D-P3DW: 19.7 in, D-P3DWL: 118 in, D-P3DWZ: 197 in
- Impact resistance — Switch: 39370 in/s²
- Insulation resistance — 50 M Ω or more at 500 VDC Mega (between lead wire and case)
- Withstand voltage — 1000 VAC for 1 minute (between lead wire and case)
- Ambient temperature — 14 to 140°F
- Enclosure — IEC60529 standard IP67
- Polarity: Non-polar

Caution

Precautions

For single-phase AC welding machines If it is used for current inverter welders (including rectifying type) and condenser type welders, the magnetic field resistance is reduced. Please contact SMC regarding the performance.

Magnetic Field Resistance

If the current of the AC welding machine is 16000 A or lower, the auto switch can be used, even if the distance between the welding conductor (gun cable) and the cylinder/actuator or auto switch is 0 in. Please contact SMC when the AC welding current exceeds 16000 A.

Mass

Unit: lb(s)

Auto switch model	D-P3DW/L/Z	
Lead wire length (in)	19.7	0.044
	118	0.225
	197	0.37

Auto Switch Internal Circuit

D-P3DW/L/Z

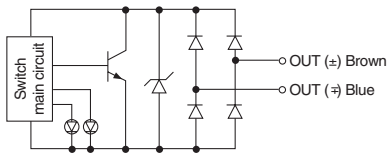

Indicator light/Display method

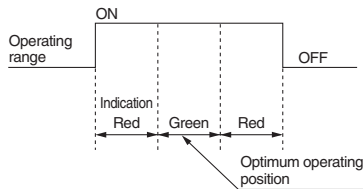

Dimensions

Unit: in

Body

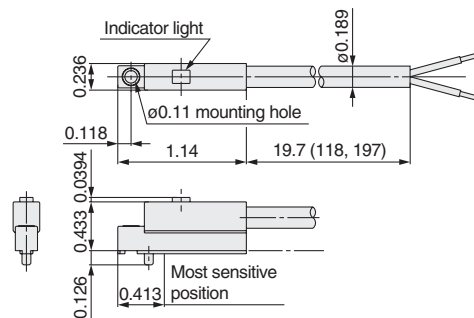

Auto switch mounting bracket (For round groove mounting: BQ3-032S)

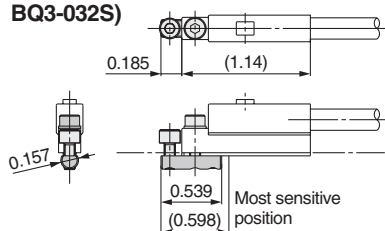

Auto switch mounting bracket (For square groove mounting: BMG5-025S)

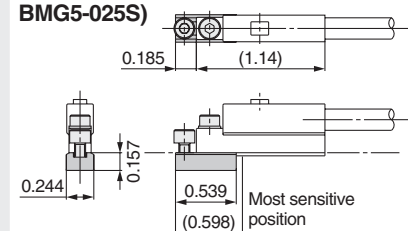

* When the auto switch is ordered on its own, the auto switch mounting bracket is not enclosed. In this case, please order it separately.



Please contact SMC for detailed specifications, lead times, and pricing.

Made to Order

Symbol	Specifications	(N)CQ2 (Standard)						(N)CQ2 (Large Bore Size)	
		Double acting		Single acting		Double acting		Single rod	Double rod
		Single rod	Double rod	Single rod	Spring return	Spring extend			
CQ2	NCQ2	CQ2	NCQ2	Spring return	Spring extend	Single rod	Double rod		
-XB6	Heat resistant cylinder (-10 to 150°C)	●	●	●	●				
-XB7	Cold resistant cylinder (-40 to 70°C)	●	●	●	●				
-XB9	Low-speed cylinder (10 to 50 mm/s)	●	●	●	●				
-XB10	Intermediate stroke (Exclusive body type)	●		●	●	●		●	●
-XB10A	Intermediate stroke (Spacer-installed type) <small>Note 3)</small>	●		●	●				
-XB11	Long stroke (Air-hydro type only)	●							
-XB13	Low-speed cylinder (5 to 50 mm/s)	●	●	●	●				
-XB14	Cylinder with heat resistant auto switch <small>Note 2)</small>	●	●						
-XC4	With heavy-duty scraper	●	●	●					
-XC6	Piston rod/Retaining ring/Rod end nut material: Stainless steel	●	●	●	●	●			
-XC8	Adjustable stroke cylinder/Adjustable extension type	●	●						
-XC9	Adjustable stroke cylinder/Adjustable retraction type	●	●						
-XC10	Dual stroke cylinder/Double rod	●	●						
-XC11	Dual stroke cylinder/Single rod	●	●						
-XC26	With split pins for double clevis pin/double knuckle joint pin and flat washers	●				●		●	
-XC27	Double clevis pin/Double knuckle joint pin material: Stainless steel 304	●				●		●	
-XC35	With coil scraper	●	●	●					
-XC36	With boss on rod end	●		●		●		●	
-X144	Special port location	●		●		●		●	
-X202	Full length dimension is the same as Series CQ1.	●				●		●	
-X203	L dimension from rod cover is the same as Series CQ1.	●				●		●	
-X235	Special rod end for double rod cylinder			●					●
-X271	Fluororubber seals	●		●		●		●	●
-X293	Full length dimension is the same as Series CQ1W.			●					
-X525	Long stroke of adjustable extension stroke cylinder (-XC8)	●							
-X526	Long stroke of adjustable retraction stroke cylinder (-XC9)	●							
-X633	Intermediate stroke of double rod cylinder			●					●
-X636	Long stroke of dual stroke single rod cylinder	●							
-X1876	Cylinder tube: With concave boss on head end	●				●		●	

(N)CQ2 (Long Stroke) Double acting	(N)CQ2K (Non-Rotating Rod) Double acting		CQP2 (Axial Piping)			CQ2□S (High Lateral Load) Double acting	CBQ2 (With End Lock) Double acting	Page
			Double acting	Single acting				
			Single rod	Single rod/ Spring return	Single rod/ Spring extend			
	Single rod	Double rod	Single rod			Single rod	Single rod	
			●					218
			●					219
			●					220
●	●	●				●		221
			●					222
●			●					223
●			●			●		224
●			●	●	●	●		225
	●							226
	●							227
	●							228
	●							229
●	● Note 1)					●	●	230
●	●	●				●		231
			●					232
			●	●	●			233
								234
								236
●			●	●	●	●		237
								238
								239
		●						240
								241
	●					●		242

Note 1) For ø40 to ø63 only. ø12 to ø32 are available as a special product. Note 2) The body shape is the same as the existing product.
 Note 3) For ø32 to ø100 only.

Standard

Single Acting

Double Rod

Axial Piping

Water Resistant

High Lateral Load

End Lock

Clean Series

Copper/Fluorine free series

Construction and Parts

Warranty and Operating Instructions

Mounting and Auto Switches

Made to Order

Series (N)CQ2 Made to Order 1

Please contact SMC for detailed dimensions, specifications, and lead times.



Symbol

-XB6 Heat Resistant Cylinder (-10 to 150°C)

The seal material and grease for air cylinders have been changed for high temperature tolerance, now with a range of -10 to 150°C.

Applicable Series

Series	Model	Action	Note
(N)CQ2	Standard	(N)CQ2	Double acting, Single rod
		(N)CQ2W	Double acting, Double rod
	Axial piping	CQP2	Double acting, Single rod

How to Order

(N)CQ2
(N)CQ2W
CQP2

Standard model no. — **XB6**

Heat resistant cylinder

Specifications

Ambient temperature range	-10 to 150°C
Seal material	Fluororubber
Grease	Heat resistant grease
Specifications other than above and external dimensions	Same as standard

Note 1) Operate without lubrication from a pneumatic system lubricator.
Note 2) For maintenance intervals for this cylinder, which differ from those of the standard cylinder, please contact SMC.

Note 3) In principle, it is not possible to make built-in magnet type and mounted auto switch models. However, for cylinders with auto switches and heat resistant cylinders with heat resistant auto switches, please contact SMC as the compatibility differs depending on the series.

Note 4) Piston speed is ranged from 50 to 500 mm/s.

Note 5) For cylinders with rubber bumper, please contact SMC.

Warning Precautions

Be aware that smoking cigarettes, etc. after your hands have come into contact with the grease used in this cylinder can create a gas that is hazardous to humans.

Symbol

-XB7 Cold Resistant Cylinder (-40 to 70°C)

The seal material and grease for air cylinders have been changed for low temperature use, down to -40°C.

Applicable Series

Series	Model	Action	Note
(N)CQ2	Standard	(N)CQ2	Double acting, Single rod
		(N)CQ2W	Double acting, Double rod
	Axial piping	CQP2	Double acting, Single rod

How to Order

(N)CQ2
(N)CQ2W
CQP2

Standard model no. — **XB7**

Cold resistant cylinder

Specifications

Ambient temperature range	-40 to 70°C
Seal material	Low nitrile rubber
Grease	Cold resistant grease
Auto switch	Not mountable
External dimensions	Same as standard
Specifications other than above	Same as standard

Note 1) Operate without lubrication from a pneumatic system lubricator.
Note 2) Use dry air which is suitable for heatless air dryer, etc. not to cause the moisture to be frozen.

Note 3) For maintenance intervals for this cylinder, which differ from those of the standard cylinder, please contact SMC.

Note 4) Mounting an auto switch is not possible.

Note 5) For cylinders with rubber bumper, please contact SMC.

Warning Precautions

Be aware that smoking cigarettes, etc. after your hands have come into contact with the grease used in this cylinder can create a gas that is hazardous to humans.

°F = 1.8°C + 32

Symbol

-XB9 Low-speed Cylinder (10 to 50 mm/s)

Even if driving at lower speeds 10 to 50 mm/s, there would be no stick-slip phenomenon and it can run smoothly.

Applicable Series

Series	Model	Action	Note
(N)CQ2	Standard	(N)CQ2	Double acting, Single rod
		(N)CQ2W	Double acting, Double rod
	Axial piping	CQP2	Double acting, Single rod

How to Order

(N)C□Q2
 (N)C□Q2W Standard model no. - XB9
 C□QP2

Low-speed cylinder ●

Note) Operate without lubrication from a pneumatic system lubricator.

Warning Precautions

Be aware that smoking cigarettes, etc. after your hands have come into contact with the grease used in this cylinder can create a gas that is hazardous to humans.

Specifications

Piston speed	10 to 50 mm/s
External dimensions	Same as standard
Specifications other than above	Same as standard

1 mm = 0.039 in

- Standard
- Single Acting
- Double Rod
- Axial Piping
- Water Resistant
- High Lateral Load
- End Lock
- Clean Series
- Copper/Fluorine free series
- Construction and Parts
- Warranty and Operating Instructions
- Mounting and Auto Switches
- Made to Order

Series (N)CQ2 Made to Order 2

Please contact SMC for detailed dimensions, specifications, and lead times.



Symbol

-XB10 Intermediate Stroke (Exclusive body type)

Air cylinder to reduce mounting space using an exclusive body rather than a spacer, so that the overall cylinder dimension is shortened.

Applicable Series

Series	Model	Action	Note	
CQ2	Standard	CQ2	Double acting, Single rod	
		CQ2W	Double acting, Double rod	
	Large bore size	CQ2	Double acting, Single rod	
		CQ2W	Double acting, Double rod	
	Long stroke	CQ2	Double acting, Single rod	
	Non-rotating rod	CQ2K	Double acting, Single rod	Except ø12 to ø32
		CQ2KW	Double acting, Double rod	
	High lateral load	CQ2□S	Double acting, Single rod	

How to Order

- C□Q2
- C□Q2W
- C□Q2K
- C□Q2KW
- C□Q2□S

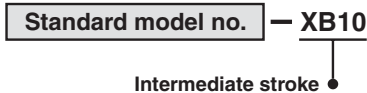

Specifications: Same as standard

Dimensions: Series CQ2

Double acting, Single rod

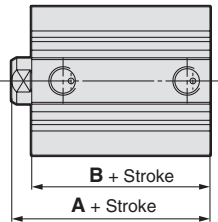

Double acting, Double rod

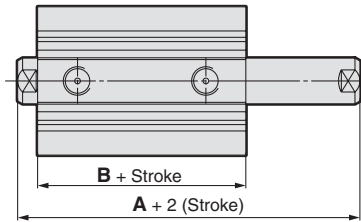

Double acting, Single rod/Long stroke

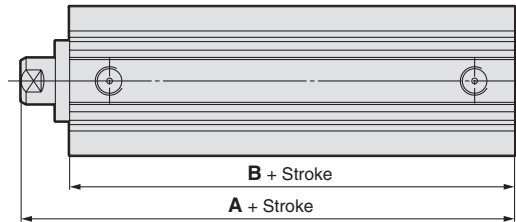

Bore size (mm)	Single rod				Applicable stroke range
	A		B		
	49 stroke or less	51 to 99 stroke	49 stroke or less	51 to 99 stroke	
12	20.5 (31.5)	—	17 (28)	—	6 to 29
16	22 (34)	—	18.5 (30.5)	—	
20	24 (36)	—	19.5 (31.5)	—	6 to 49
25	27.5 (37.5)	—	22.5 (32.5)	—	
32	30 (40)	40 (40)	23 (33)	33 (33)	6 to 99
40	36.5 (46.5)	46.5 (46.5)	29.5 (39.5)	39.5 (39.5)	
50	38.5 (48.5)	48.5 (48.5)	30.5 (40.5)	40.5 (40.5)	11 to 99
63	44 (54)	54 (54)	36 (46)	46 (46)	
80	53.5 (63.5)	63.5 (63.5)	43.5 (53.5)	53.5 (53.5)	
100	65 (75)	75 (75)	53 (63)	63 (63)	

(mm)

Bore size (mm)	Single rod (Long stroke)		Applicable stroke range
	A	B	
32	62.5	45.5	101 to 299
40	72	55	
50	73.5	55.5	
63	75	57	
80	86	66	
100	97.5	75.5	

(mm)

* The dimensions are the same with or without auto switch.

* (): Dimensions with auto switch
* The dimensions other than listed are the same as those of the standard.

Note) Applicable stroke: Available in 1 mm intervals

Bore size (mm)	Double rod				Applicable stroke range
	A		B		
	49 stroke or less	51 to 99 stroke	49 stroke or less	51 to 99 stroke	
12	32.2 (39.4)	—	25.2 (32.4)	—	6 to 29
16	33 (43)	—	26 (36)	—	
20	35 (47)	—	26 (38)	—	6 to 49
25	39 (49)	—	29 (39)	—	
32	44.5 (54.5)	54.5 (54.5)	30.5 (40.5)	40.5 (40.5)	6 to 99
40	54 (64)	64 (64)	40 (50)	50 (50)	
50	56.5 (66.5)	66.5 (66.5)	40.5 (50.5)	50.5 (50.5)	11 to 99
63	58 (68)	68 (68)	42 (52)	52 (52)	
80	71 (81)	81 (81)	51 (61)	61 (61)	
100	84.5 (94.5)	94.5 (94.5)	60.5 (70.5)	70.5 (70.5)	

(mm)

Bore size (mm)	Single rod (Single acting/Spring return)		Applicable stroke range
	A	B	
12	20.5 (31.5)	17 (28)	6 to 9
16	22 (34)	18.5 (30.5)	
20	24 (36)	19.5 (31.5)	6 to 9
25	27.5 (37.5)	22.5 (32.5)	
32	30 (40)	23 (33)	6 to 9
40	36.5 (46.5)	29.5 (39.5)	
50	38.5 (48.5)	30.5 (40.5)	11 to 19

(mm)

Series (N)CQ2 Made to Order 3

Please contact SMC for detailed dimensions, specifications, and lead times.



Symbol

-XB11 Long Stroke (Air-hydro type only)

Strokes exceeding the standard stroke length

Applicable Series

Series	Model	Action	Note	
CQ2	Air-hydro type (ø32 to ø100)	CQ2AH	Double acting, Single rod	The external dimensions are the same as those of the CQ2 series long stroke type air cylinder.

How to Order

Standard model no. **-XB11**

Long stroke
* Enter a symbol for stroke required.

Specifications: Same as standard

Symbol

-XB13 Low-speed Cylinder (5 to 50 mm/s)

Even if driving at lower speeds 5 to 50 mm/s, there would be no stick-slip phenomenon and it can run smoothly.

Applicable Series

Series	Model	Action	Note	
(N)CQ2	Standard	(N)CQ2	Double acting, Single rod	Except Large bore size, Long stroke, Non-rotating rod, High lateral load, With end lock
		(N)CQ2W	Double acting, Double rod	
	Axial piping	CQP2	Double acting, Single rod	

How to Order

(N)C□Q2
(N)C□Q2W
C□QP2

Standard model no. **-XB13**

Low-speed cylinder

Note 1) Operate without lubrication from a pneumatic system lubricator.
Note 2) For speed control, use the low-speed-control speed controller (Series AS-FM/AS-M).

Specifications

Piston speed	5 to 50 mm/s
External dimensions	Same as standard
Specifications other than above	Same as standard

Warning Precautions

Be aware that smoking cigarettes, etc. after your hands have come into contact with the grease used in this cylinder can create a gas that is hazardous to humans.

1 mm = 0.039 in

Symbol

-XB14 Cylinder with Heat Resistant Auto Switch

Heat resistant compact cylinder CDQ2 series (ø16 to ø63), which can mount heat resistant solid state switch. (D-F7NJ½, Max. 150°C)

Applicable Series

Series	Model	Action	Note
CQ2	Standard	CQ2	Double acting, Single rod Applicable to ø16 to ø63 Except with rubber bumper Body shape: Same as the existing product

How to Order

CDQ2 Standard model no. - F7NJL - XB14

Note) The body shape is the same as the existing product.
"Z" is not included in the model number.

● Cylinder with heat resistant auto switch

Specifications

Applicable cylinder	Compact cylinder/Standard
Series	CQ2
Bore size (mm)	16, 20, 25, 32, 40, 50, 63
Type	Non-lube
Fluid	Air
Proof pressure	218 psi (1.5 MPa)
Maximum operating pressure	145 psi (1.0 MPa)
Minimum operating pressure	0.05 MPa (0.07 MPa: for ø16 only)
Ambient and fluid temperature	0 to 150°C
Rubber bumper	None
Rod end thread	Male or female thread
Stroke length tolerance	+1.0 0 mm
Piston speed	50 to 500 mm/s

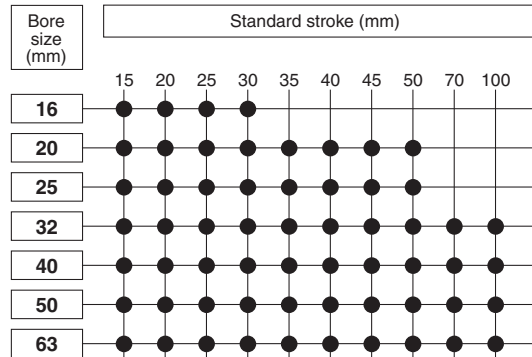

• Manufacture of intermediate strokes
Intermediate strokes in 1 mm intervals are available by installing a spacer in the standard stroke cylinder.

Note) Refer to page 1319 in Best Pneumatics No. 2 for further information on auto switches.

Auto Switch Proper Mounting Position (Detection at Stroke End)

ø16 to ø25

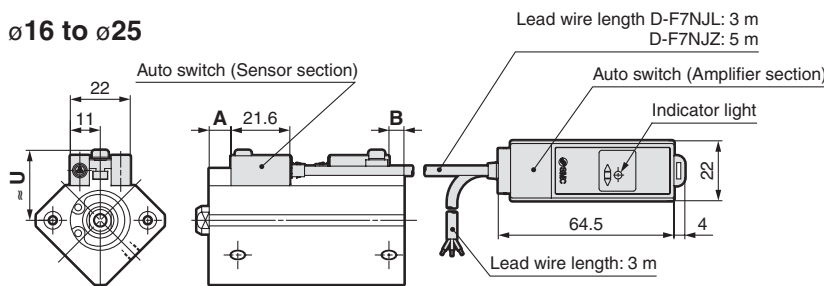

Bore size (mm)	(mm)		
	A	B	U
16	8	5.5	23.5
20	8	7	25.5
25	8	7.5	28.5
32	9.5	6.5	32.5
40	13.5	9	36
50	11.5	12	42
63	14	15	48.5

ø32 to ø63

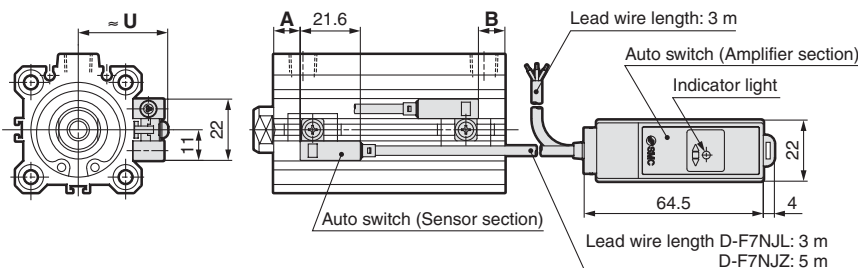

Auto Switch Mounting Bracket/Part No.

Auto switch model	Bore size (mm)					
	16	20	25	32	40	50
D-F7NJL(Z)	BQ-1			BQJ1-032		

Auto Switch Mounting Bracket/Weight

Mounting bracket part no.	Weight (g)
BQ-1	1.5
BQJ1-032	8.5

* The dimensions on the cylinder body is equivalent to the standard, double acting, single rod of the CDQ2 series.

Note 1) Auto switches are shipped in the same package, but not assembled in order to protect it at the time of shipment.

Assemble it by referring to A, B dimensions for mounting position shown in the above table.

Note 2) The tightening torque of the auto switch mounting M3 screw must be 0.5 to 0.7 N-m.

1 MPa = 145 psi

1 mm = 0.039 in

°F = 1.8°C + 32

Series (N)CQ2 Made to Order 4

Please contact SMC for detailed dimensions, specifications, and lead times.



Symbol

-XC4 With Heavy-Duty Scraper

Suitable for using cylinders in a dusty environment, or where cylinders are exposed to dirt or sand.

Applicable Series

Series	Model	Action	Note
(N)CQ2	Standard	(N)CQ2	Double acting, Single rod
		(N)CQ2W	Double acting, Double rod
	Long stroke	(N)CQ2	Double acting, Single rod
	Axial piping	CQP2	Double acting, Single rod
			ø20 to ø100
			ø32 to ø100

How to Order

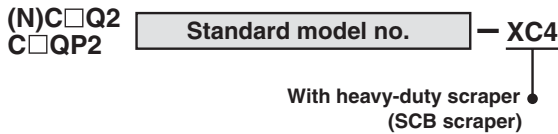

Specifications: Same as standard

⚠ Caution

Do not replace heavy-duty scrapers.

- Since heavy-duty scrapers are press-fit, replace the entire rod cover assembly.

Series (N)CQ2

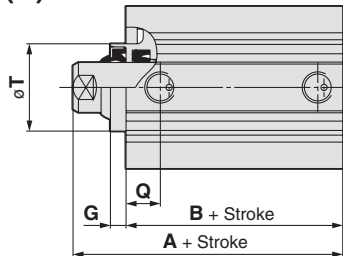

- (): Dimensions with auto switch
 - The other dimensions are the same as those of the standard, CQ2 series.
 - ø32, without switch, 5 mm stroke: Q-dimension is 21.5
 - Relation between ø12 to ø32 piping port and mounting holes is as the diagram on the right.
- For models with a bracket, please contact SMC.
Applicable stroke: Available in 5 mm intervals



Without switch: ø20 to ø32
With switch: ø32

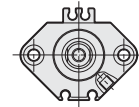

With switch: ø20, ø25

Series (N)CQ2

Bore size (mm)	A			B			T	G		Q	
	50 stroke or less	75, 100 stroke	125 to 300 stroke	50 stroke or less	75, 100 stroke	125 to 300 stroke		100 stroke or less	125 stroke or more	50 stroke or less	125 stroke or more
20	34 (46)	—	—	29.5 (41.5)	—	—	—	—	—	19 (20.5)	—
25	37.5 (47.5)	—	—	32.5 (42.5)	—	—	—	—	—	21 (21)	—
32	40 (50)	50 (50)	67.5 (67.5)	33 (43)	43 (43)	55.5 (55.5)	—	—	—	20.5 (20.5)	—
40	46.5 (56.5)	56.5 (56.5)	77 (77)	29.5 (39.5)	39.5 (39.5)	55 (55)	28	5	10	11 (11)	14 (14)
50	48.5 (58.5)	58.5 (58.5)	78.5 (78.5)	30.5 (40.5)	40.5 (40.5)	55.5 (55.5)	35	5	10	10.5 (10.5)	14 (14)
63	54 (64)	64 (64)	80 (80)	36 (46)	46 (46)	57 (57)	35	5	10	15 (15)	16.5 (16.5)
80	63.5 (73.5)	73.5 (73.5)	91 (91)	43.5 (53.5)	53.5 (53.5)	66 (66)	43	5	10	16 (16)	19 (19)
100	75 (85)	85 (85)	102.5 (102.5)	53 (63)	63 (63)	75.5 (75.5)	59	5	10	23 (23)	23 (23)

Symbol

-XC6 Piston Rod/Retaining Ring/Rod End Nut Material: Stainless Steel

Suitable for cases likely to generate rust by water immersion or corrosion.

Applicable Series

Series	Model	Action	Note	
(N)CQ2	Standard	(N)CQ2	Double acting, Single rod	
		(N)CQ2W	Single acting (Spring return/extend)	
	Long stroke	(N)CQ2	Double acting, Double rod	
	Axial piping	CQP2	Double acting, Single rod	
			Single acting (Spring return/extend)	
	High lateral load	CQ2□S	Double acting, Single rod	

How to Order

(N)C□Q2
(N)C□Q2W
C□QP2
C□Q2□S

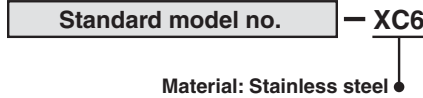

Specifications

Parts changed to stainless steel	Piston rod, Rod end nut
Specifications other than above and external dimensions	Same as standard

Note) Retaining ring and piston rod are made of stainless steel.
Rod end nut is also made of stainless steel for rod end male thread type.

Series CQ(P)2^R

Piston rod and rod end nut (male thread only) have been changed to stainless steel specification "-XC6". Also, the materials for hexagon socket head cap screws to fix ø20 to ø32 rod covers have been changed to stainless steel.

Applicable Series

Series	Model	Action	Note
CQ2	Water resistant compact cylinder	C□Q2□ ^R	Double acting, Single rod
	Water resistant, axial piping	C□QP2□ ^R	Double acting, Single rod

How to Order

C□Q2□^R
C□QP2□^R

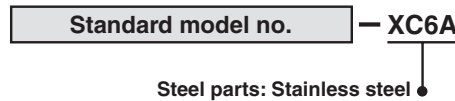

Specifications

Parts changed to stainless steel	Piston rod, Rod end nut (male thread only), Rod cover holding hexagon socket head cap screw
Specifications other than above and external dimensions	Same as standard

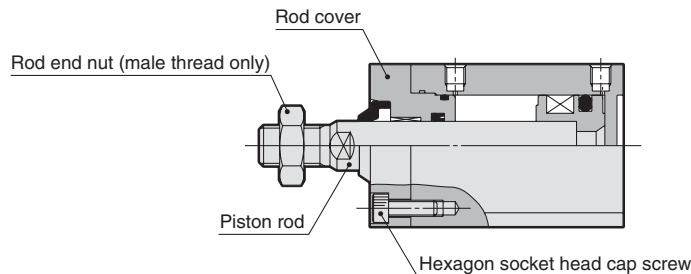

- Standard
- Single Acting
- Double Rod
- Axial Piping
- Water Resistant
- High Lateral Load
- End Lock
- Clean Series
- Copper/Fluorine free series
- Construction and Parts
- Warranty and Operating Instructions
- Mounting and Auto Switches
- Made to Order

Series (N)CQ2 Made to Order 5

Please contact SMC for detailed dimensions, specifications, and lead times.



Symbol

-XC8 Adjustable Stroke Cylinder/Adjustable Extension Type

The extending stroke by the cylinder can be adjusted by the stroke adjustment mechanism equipped on the head end.

Applicable Series

Series	Model	Action	Note	
(N)CQ2	Standard	(N)CQ2	Double acting	Except with rubber bumper and with bracket
	Non-rotating rod	(N)CQ2K	Double acting	Except with rubber bumper and with bracket
	Air-hydro type	CQ2H	Double acting	

How to Order

(N)C□Q2B(H)
(N)C□Q2K

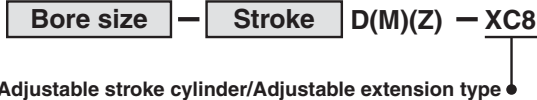

Specifications

Series	Stroke adjustment range (mm)
(N)CQ2	0 to 10

Note) The specifications other than above are the same as those of the standard.

Precautions

Warning

- When the cylinder is operating, if something gets caught between the stopper bracket for adjusting the stroke and the cylinder body, it could cause bodily injury or damage the peripheral equipment. Therefore, take preventive measures as necessary, such as installing a protective cover.
- To adjust the stroke, make sure to secure the wrench flats of the stopper bracket by a wrench, etc. before loosening the lock nut. If the lock nut is loosened without securing the stopper bracket, be aware that the area that joins the load to the piston rod or the area in which the piston rod is joined with the load side and the stopper bracket side could loosen first. It may cause an accident or malfunction.

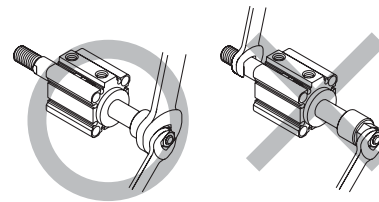

Symbol

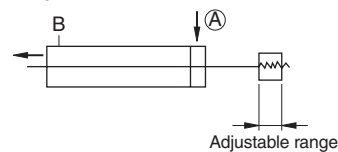

Series (N)CQ2/CQ2H

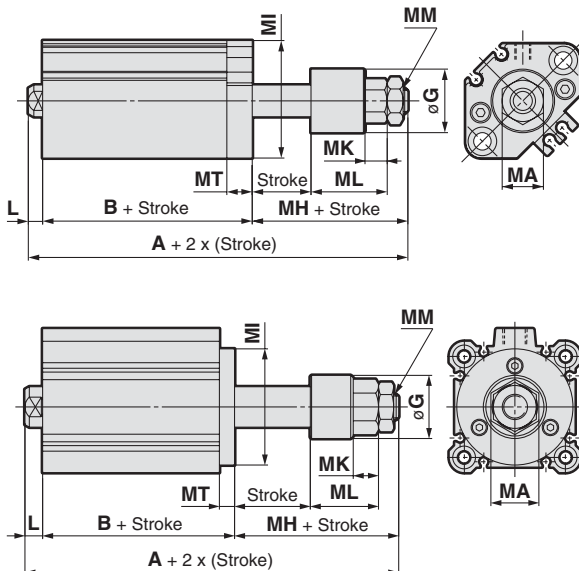

Bore size	(mm)											
	A	B	L	MH	MT	MA	MI	MM	MK	ML	øG	Stroke range
12	57.7 (64.9)	30.2 (37.4)	3.5	24	5	8	□25	M4 x 0.7	5.5	20	14	5 to 30
16	58.5 (68.5)	31 (41)	3.5	24	5	10	□28	M5 x 0.8	5.5	20	14	
20	67.5 (79.5)	34 (46)	4.5	29	8	12	□36	M6 x 1	7	24	20	5 to 50
25	71 (81)	37 (47)	5	29	8	12	□40	M6 x 1	7	24	20	
32	78.5 (88.5)	36.5 (46.5)	7	35	6	17	ø38	M8 x 1.25	9	28.5	25	5 to 50
	88.5	46.5										
40	88 (98)	46 (56)	7	35	6	19	ø46	M10 x 1.25	10	27	25	5 to 50
	98	56										
50	100.5 (110.5)	48.5 (58.5)	8	44	8	24	ø57	M14 x 1.5	13	31	35	10 to 50
	110.5	58.5										
63	102 (112)	52 (62)	8	42	10	24	ø68	M14 x 1.5	13	31	35	10 to 50
	112	62										
80	125 (135)	63 (73)	10	52	12	32	ø90	M20 x 1.5	16	40	45	10 to 50
	135	73										
100	138.5 (148.5)	74.5 (84.5)	12	52	14	32	ø110	M20 x 1.5	16	40	45	10 to 50
	148.5	84.5										

Note 1) (): Dimensions with auto switch

Note 2) Applicable stroke: Available in 5 mm intervals

Symbol

-XC9 Adjustable Stroke Cylinder/Adjustable Retraction Type

The retracting stroke of the cylinder can be adjusted by the adjusting bolt.

Applicable Series

Series	Model	Action	Note
(N)CQ2	Standard	Double acting, Single rod	Except with rubber bumper and with bracket
	Non-rotating rod		

How to Order

(N)C□Q2B **Bore size** — **Stroke** D(M)(Z) — **XC9**
 Adjustable stroke cylinder/Adjustable retraction type

Specifications

Series	Stroke adjustment range (mm)
(N)CQ2	0 to 10

Note) The specifications other than above are the same as those of the standard.

Precautions

Warning

- When air is supplied to the cylinder, if the stroke adjusting bolt is loosened in excess of the allowable stroke adjustment amount, be aware that the stroke adjusting bolt could fly out or air could be discharged, which could cause bodily injury or damage the peripheral equipment.
- Adjust the stroke when the cylinder is not pressurized. If it is adjusted in the pressurized state, the seal of the adjustment section could become deformed, leading to air leakage.

Symbol

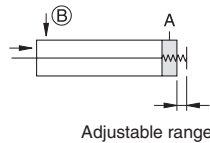

Series (N)CQ2

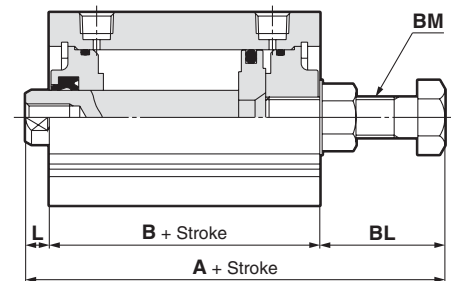

Bore size (mm)	A	B	L	BL	BM	Stroke range
12	52 (59.2)	25.2 (32.4)	3.5	23.3	M5 x 0.8	5 to 30
16	53 (63)	26 (36)	3.5	23.5	M6 x 1	
20	61 (73)	26 (38)	4.5	30.5	M8 x 1.25	5 to 50
25	63.5 (73.5)	29 (39)	5	29.5	M8 x 1.25	
32	65.5 (75.5)	30.5 (40.5)	7	28	M8 x 1.25	
40	84 (94)	40 (50)	7	37	M12 x 1.5	10 to 50
50	84.5 (94.5)	40.5 (50.5)	8	36	M12 x 1.5	
63	88.5 (98.5)	42 (52)	8	38.5	M16 x 1.5	
80	109.5 (119.5)	51 (61)	10	48.5	M20 x 1.5	
100	125 (135)	60.5 (70.5)	12	52.5	M24 x 1.5	

Note 1) (): Dimensions with auto switch
 Note 2) Applicable stroke: Available in 5 mm intervals

Standard

Single Acting

Double Rod

Axial Piping

Water Resistant

High Lateral Load

End Lock

Clean Series

Copper/Fluorine free series

Construction and Parts

Warranty and Operating Instructions

Mounting and Operating Auto Switches

Made to Order

Series (N)CQ2 Made to Order 6

Please contact SMC for detailed dimensions, specifications, and lead times.



Symbol

-XC10 Dual Stroke Cylinder/Double Rod

Two cylinders are constructed as one cylinder in a back-to-back configuration allowing the cylinder stroke to be controlled in three steps.

Applicable Series

Series	Model	Action	Note
(N)CQ2	Standard	(N)CQ2	Double acting, Single rod
	Non-rotating rod	(N)CQ2K	
	Air-hydro type	CQ2H	

How to Order

(N)C□Q2B Bore size - Stroke S₁ + Stroke S₂ D(C)(M)(Z) - XC10
 (N)C□Q2K
 Dual stroke cylinder ↓

Specifications

Series	Bore size (mm)	Max. manufacturable stroke (mm)
CQ2	12, 16	60 (Max. on single side: 30)
	20, 25	100 (Max. on single side: 50)
	32, 40	200 (Max. on single side: 100)
	50 to 100	200 (Max. on single side: 100)

Note) The specifications other than above are the same as those of the standard.

Dimensions (Other dimensions are the same as those of the standard.)

Series (N)CQ2

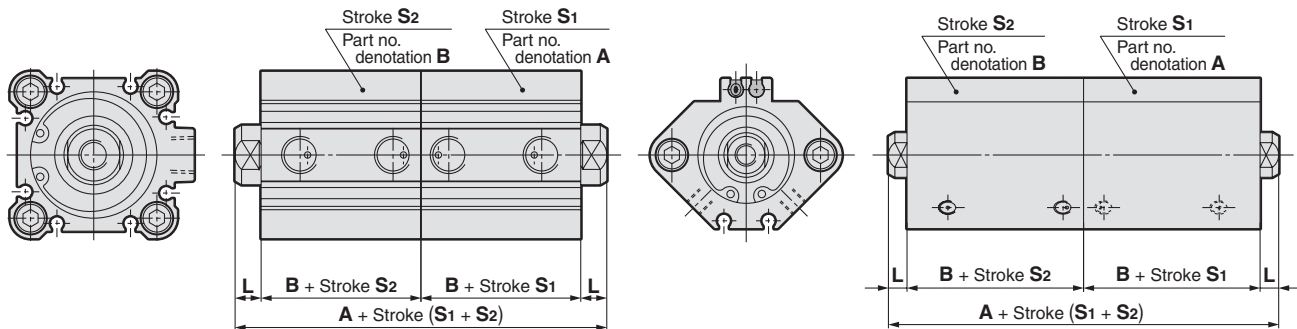

Note) In the case of $\phi 12$ to $\phi 25$ with auto switch, port directions are different.

Bore size	A		B		L	Stroke Both of S ₁ , S ₂
	50 st or less	75, 100 st	50 st or less	75, 100 st		
12	41 (63)	—	17 (28)	—	3.5	5 to 30
16	44 (68)	—	18.5 (30.5)	—	3.5	
20	48 (72)	—	19.5 (31.5)	—	4.5	5 to 50
25	55 (75)	—	22.5 (32.5)	—	5	
32	60 (80)	80 (80)	23 (33)	33 (33)	7	5 to 100
40	73 (93)	93 (93)	29.5 (39.5)	39.5 (39.5)	7	
50	77 (97)	97 (97)	30.5 (40.5)	40.5 (40.5)	8	
63	88 (108)	108 (108)	36 (46)	46 (46)	8	10 to 100
80	107 (127)	127 (127)	43.5 (53.5)	53.5 (53.5)	10	
100	130 (150)	150 (150)	53 (63)	63 (63)	12	

Note 1) (): Dimensions with auto switch

Note 2) Applicable stroke: Available in 5 mm intervals

Symbol

-XC11 Dual Stroke Cylinder/Single Rod

Two cylinders can be integrated by connecting them in line, and the cylinder stroke can be controlled in two stages in both directions.

Applicable Series

Series	Model	Action	Note
(N)CQ2	Standard	Double acting, Single rod	Except with bracket
	Air-hydro type		

How to Order

(N)C□Q2B Bore size - Stroke S₁ + Stroke S₂ - S₁ D(C)(M)(Z) - XC11

Dual stroke cylinder/Single rod

Specifications: Same as standard

(For manufacturable strokes, please contact SMC.)

Construction/Dimensions

Series (N)CQ2

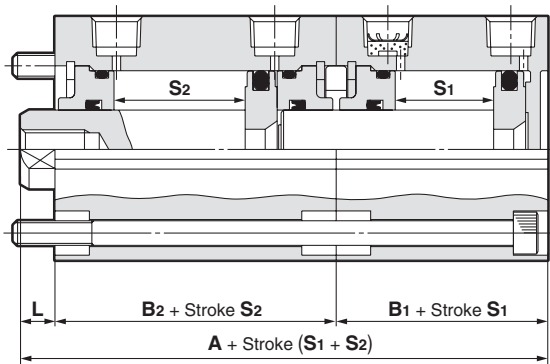

Bore size (mm)	A	B ₁	B ₂	L	Stroke Both of S ₁ , S ₂
12	45.7 (63.9)	17 (28)	25.2 (32.4)	3.5	5 to 30
16	48 (70)	18.5 (30.5)	26 (36)	3.5	
20	50 (74)	19.5 (31.5)	26 (38)	4.5	
25	56.5 (76.5)	22.5 (32.5)	29 (39)	5	5 to 50
32	60.5 (80.5)	23 (33)	30.5 (40.5)	7	
40	76.5 (96.5)	29.5 (39.5)	40 (50)	7	
50	79 (99)	30.5 (40.5)	40.5 (50.5)	8	10 to 50
63	86 (106)	36 (46)	42 (52)	8	
80	104.5 (124.5)	43.5 (53.5)	51 (61)	10	
100	125.5 (145.5)	53 (63)	60.5 (70.5)	12	

Note 1) (): Dimensions with auto switch
 Note 2) Applicable stroke: Available in 5 mm intervals
 Note 3) For long stroke type, please contact SMC.

- Standard
- Single Acting
- Double Rod
- Axial Piping
- Water Resistant
- High Lateral Load
- End Lock
- Clean Series
- Copper/Fluorine free series
- Construction and Parts
- Warranty and Operating Instructions
- Mounting and Auto Switches
- Made to Order



Symbol

-XC26 With Split Pins for Double Clevis Pin/Double Knuckle Joint Pin and Flat Washers

A pin for double clevis (one of the mounting types) or double knuckle joint (one of the accessories) has been changed for a split pin, and split pins and flat washers have been added.

Applicable Series

Series	Model	Action	
CQ2	Standard	Double acting, Single rod	
		Single acting (Spring ret./ext.)	
	Long stroke	CQ2□	Double acting, Single rod
	Non-rotating rod	CQ2K	Double acting, Single rod
	High lateral load	CQ2□S	Double acting, Single rod
	With end lock	CBQ2	Double acting, Single rod
	Magnetic field resistant	CDQ2□P	Double acting, Single rod
	Copper-free compact	20-CQ2	Double acting, Single rod
			Single acting (Spring ret./ext.)
	Copper-free long stroke	20-CQ2□	Double acting, Single rod
Copper-free high-lateral load	20-CQ2□S	Double acting, Single rod	

Specifications

Mounting	Double clevis (D) only
Changed parts	Clevis pin/Knuckle pin, Split pin, Flat washer
Specifications other than above	Same as standard

Dimensions: Same as Standard

How to Order

● **Product**

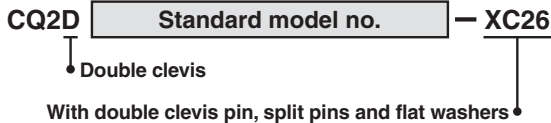

● **Parts assembly**

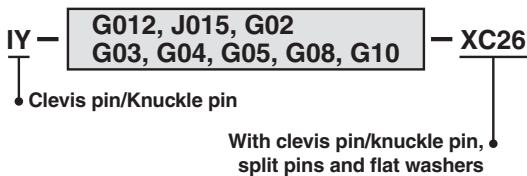
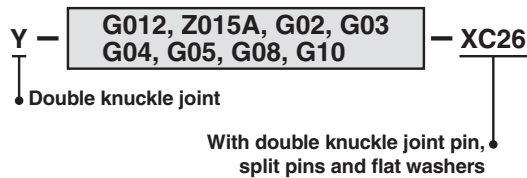
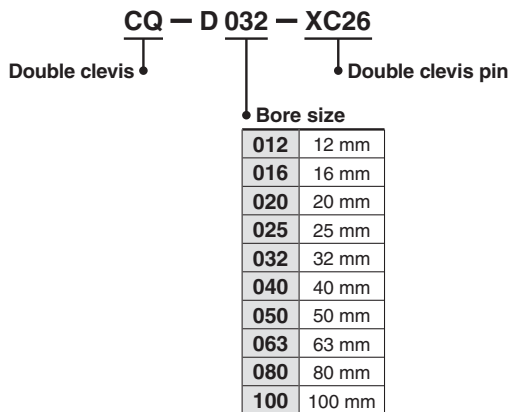

Double clevis

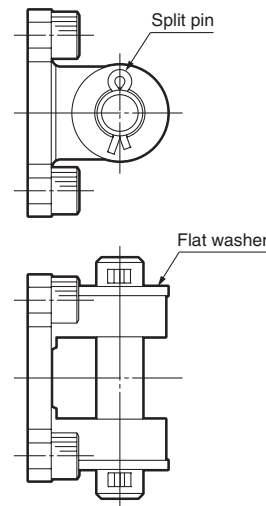

* For mounting bracket, split pins, clevis pin and flat washers are shipped together, (but not assembled).
* Mounting method is the same as standard.

Double knuckle joint

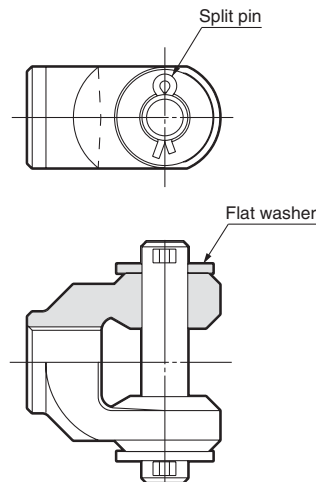

* For mounting bracket, split pins, knuckle pin and flat washers are shipped together, (but not assembled).
* Mounting method is the same as standard.

Symbol

-XC27 Double Clevis Pin/Double Knuckle Joint Pin Material: Stainless Steel 304

For preventing the oscillating portion of the double clevis or the double knuckle joint from rusting, the material of the pin and the retaining ring (split pin) has been changed to stainless steel.

Applicable Series

Series	Model	Action	
CQ2	Standard	CQ2	Double acting, Single rod
			Single acting (Spring ret./ext.)
	Long stroke	CQ2□	Double acting, Single rod
	Non-rotating rod	CQ2K	Double acting, Single rod
	High lateral load	CQ2□S	Double acting, Single rod
	Magnetic field resistant	CDQ2□P	Double acting, Single rod
	Copper-free compact	20-CQ2	Double acting, Single rod
			Single acting (Spring ret./ext.)
Copper-free long stroke	20-CQ2□	Double acting, Single rod	
Copper-free high lateral load	20-CQ2□S	Double acting, Single rod	

Specifications

Mounting	Double clevis (D) only
Pin material	Stainless steel 304
Specifications other than above	Same as standard

Dimensions: Same as Standard

- * For mounting bracket, clevis pin/knuckle pin and retaining rings are shipped together, (but not assembled).
- * Mounting method is the same as standard.

How to Order

● **Product**

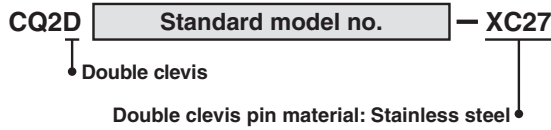

● **Parts assembly**

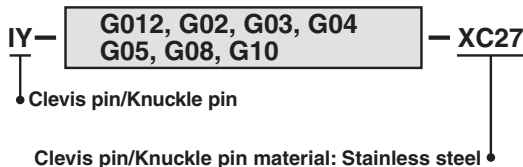
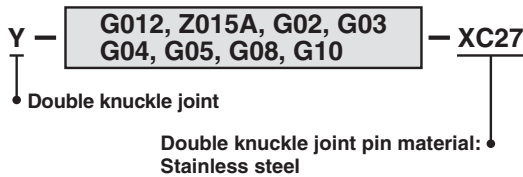
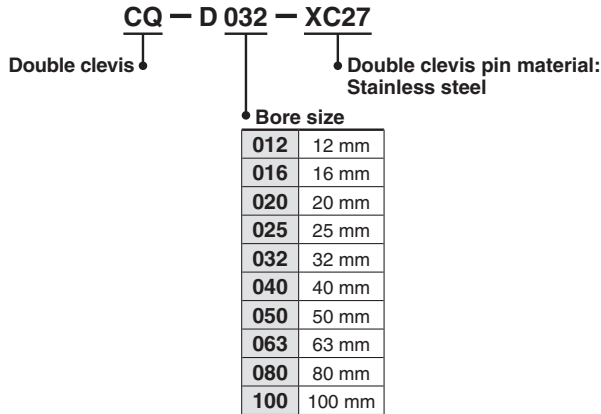

* Stainless steel specification for IY-J015 is IY-J015SUS.

Standard

Single Acting

Double Rod

Axial Piping

Water Resistant

High Lateral Load

End Lock

Clean Series

Copper/Fluorine free series

Construction and Parts

Warranty and Operating Instructions

Mounting and Auto Switches

Made to Order

Series (N)CQ2 Made to Order 8

Please contact SMC for detailed dimensions, specifications, and lead times.



Symbol

-XC35 With Coil Scraper

For getting rid of frost, ice, weld spatter, cutting chips adhered to the piston rod, and for protecting the seals, etc.

Applicable Series

Series	Model	Action	Note
(N)CQ2	Standard	(N)CQ2	Applicable to $\phi 32$ to $\phi 100$, Except with bracket
		(N)CQ2W	
	Axial piping	CQP2	

How to Order

Standard model no. — **XC35**

With coil scraper ●

Specifications: Same as standard

Series (N)CQ2

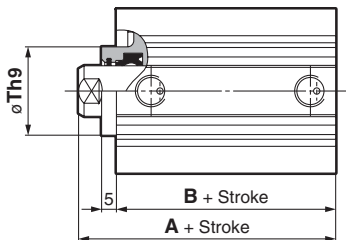

Bore size (mm)	A		B		Th9
	50 stroke or less	51 to 100 stroke	50 stroke or less	51 to 100 stroke	
32	35 (45)	45 (45)	23 (33)	33 (33)	23 ⁰ _{-0.052}
40	41.5 (51.5)	51.5 (51.5)	29.5 (39.5)	39.5 (39.5)	28 ⁰ _{-0.052}
50	43.5 (53.5)	53.5 (53.5)	30.5 (40.5)	40.5 (40.5)	35 ⁰ _{-0.062}
63	49 (59)	59 (59)	36 (46)	46 (46)	35 ⁰ _{-0.062}
80	58.5 (68.5)	68.5 (68.5)	43.5 (53.5)	53.5 (53.5)	43 ⁰ _{-0.062}
100	70 (80)	80 (80)	53 (63)	63 (63)	59 ⁰ _{-0.074}

Note 1) (): Dimensions with auto switch

Note 2) Applicable stroke: Available in 5 mm intervals

Symbol

-XC36 With Boss on Rod End

Cylinder with boss on rod end

Applicable Series

Series	Model	Action	
CQ2	Standard	CQ2	
		CQ2W	
	Axial piping	CQP2	Double acting, Single rod
			Single acting (Spring return/extend)

Note 1) For double rod type, it comes with boss on both ends.

Note 2) Except with bracket

Note 3) Except $\phi 125$ or more

How to Order

Standard model no. — **XC36**

With boss on rod end ●

Specifications: Same as standard

Dimensions

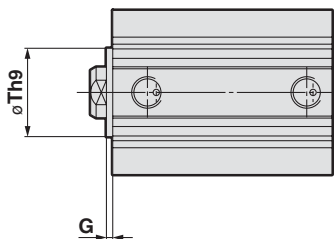

* The dimensions except mentioned above are the same as those of the standard.

Series	CQ2	
	Th9	G
12	15 ⁰ _{-0.043}	1.5
16	20 ⁰ _{-0.052}	1.5
20	13 ⁰ _{-0.043}	2
25	15 ⁰ _{-0.043}	2
32	21 ⁰ _{-0.052}	2
40	28 ⁰ _{-0.052}	2
50	35 ⁰ _{-0.062}	2
63	35 ⁰ _{-0.062}	2
80	43 ⁰ _{-0.062}	2
100	59 ⁰ _{-0.074}	2



Symbol

-X144 Special Port Location

For changing port location (ø12 to ø25 with auto switch only)

How to Order

CDQ2 Standard model no. — X144 B

Special port location

In the case of CDQ2□20/25, specify the port location with B, C and D.

Applicable Model

Action	Note
Double acting, Single rod	Applicable to ø12 to ø25
Double acting, Double rod	
Single acting (Spring return/extend)	

Note) The specifications are the same as those of the CDQ2 series.

ø12, ø16

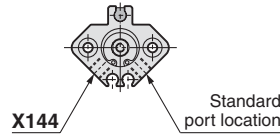

ø20, ø25

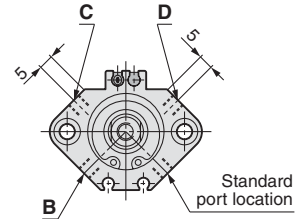

- Standard
- Single Acting
- Double Rod
- Axial Piping
- Water Resistant
- High Lateral Load
- End Lock
- Clean Series
- Copper/Fluorine free series
- Construction and Parts
- Warranty and Operating Instructions
- Mounting and Auto Switches
- Made to Order

Series (N)CQ2 Made to Order Individual Specifications 2

Please contact SMC for detailed dimensions, specifications, and lead times.



Symbol

-X202 Full Length Dimension is the Same as the CQ1 Series.

C□Q2 **Mounting** **Bore size** — **Stroke** **Action** **Option** (Z) — X202

In a single rod cylinder of the CQ2 series, the A dimension (from the head face to the rod end) and the rod end female thread size are the same as those of the CQ1 series (former model).

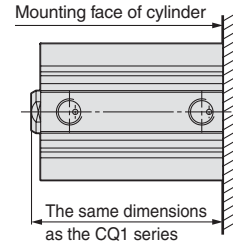

The specifications are the same as those of the standard, CQ2 series.

Applicable Model

Action		Note
Single rod	Double acting (Rubber bumper)	Applicable to $\phi 12$, $\phi 20$, $\phi 32$, $\phi 40$, $\phi 50$, $\phi 63$, $\phi 80$, $\phi 100$
	Single acting (Spring return/Spring extend)	Applicable to $\phi 12$, $\phi 20$, $\phi 32$, $\phi 40$, $\phi 50$

Note 1) $\phi 16$ and $\phi 25$ are the new models so that they are not applicable.
 Note 2) Strokes except mentioned below are available as standard products.

Dimensions (Without auto switch)

Double acting,
Single rod: Female thread

H thread effective depth C

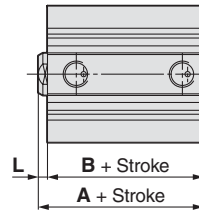
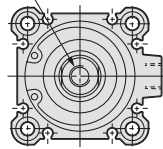

Symbol	Bore size		$\phi 12$		$\phi 20$		$\phi 32$		$\phi 40$		$\phi 50$		$\phi 63$		$\phi 80$		$\phi 100$	
	Stroke (mm)		15, 25	5, 10 20, 30 40, 50	15, 25 35, 45	5, 10 20, 30 40, 50	15, 25 35, 45	5, 10 20, 30 40, 50	15, 25 35, 45	10, 20 30, 40 50	15, 25 35, 45	10, 20 30, 40 50	15, 25 35, 45	10, 20 30, 40 50	15, 25 35, 45	10, 20 30, 40 50	15, 25 35, 45	
A	25.5	23(25)	28	26.5 (28.5)	31.5	33	38	34	39	39.5	44.5	47	52	56.5	61.5			
B	22	19.5	24.5	23	28	29.5	34.5	30.5	35.5	36	41	43.5	48.5	53	58			
L	3.5	3.5 (5.5)	3.5	3.5 (5.5)	3.5	3.5	3.5	3.5	3.5	3.5	3.5	3.5	3.5	3.5	3.5			
H	M3 x 0.5	M5 x 0.8	M6 x 1.0*	M6 x 1.0*	M8 x 1.25*	M10 x 1.5	M16 x 2.0	M20 x 2.5										
C	6	7	9*	11*	13*	15	21	27										

Note) (): Stroke 10 mm * The H/C dimensions of $\phi 32$, $\phi 40$ and $\phi 50$ are different from those of the new CQ2 series model.

75 st, 100 st

Symbol	Bore size		$\phi 32$		$\phi 40$		$\phi 50$		$\phi 63$		$\phi 80$		$\phi 100$	
	Stroke		75 100	75 100	75 100	75 100	75 100	75 100	75 100					
A	36.5	43	44	49.5	57	66.5								
B	33	39.5	40.5	46	53.5	63								
L	3.5	3.5	3.5	3.5	3.5	3.5								

Note) The H/C dimensions are the same as above.

Single acting

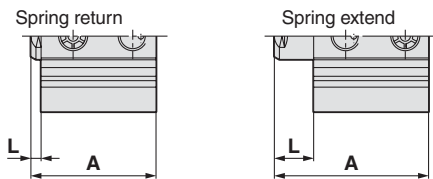

Double acting: Rod end male thread

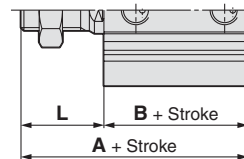

Action	Bore size Stroke Symbol	$\phi 20$		$\phi 32$		$\phi 40$		$\phi 50$	
		5 10	5 10	5 10	10 20				
Single acting, Spring return	A	28 35	31.5 38.5	38 43	44 54				
	L	3.5 5.5	3.5 5.5	3.5	3.5				
Single acting, Spring extend	A	33 45	36.5 48.5	43 53	54 74				
	L	8.5 15.5	8.5 15.5	8.5 13.5	13.5 23.5				

Bore size Stroke Symbol	$\phi 12$		$\phi 20$		$\phi 32$		$\phi 40$		$\phi 50$		$\phi 63$		$\phi 80$		$\phi 100$	
	15, 25	10	15, 25 35, 45	10	15, 25 35, 45	15, 25 35, 45	15, 25 35, 45	15, 25 35, 45	15, 25 35, 45	15, 25 35, 45	15, 25 35, 45					
A	36	40	43	53.5	56.5	63	69	74.5	92	101.5						
B	22	19.5	24.5	23	28	34.5	35.5	41	48.5	58						
L	14	20.5	18.5	30.5	28.5	28.5	33.5	33.5	43.5	43.5						

Symbol
-X202

Dimensions (With auto switch)

Double acting, Single rod: Female thread

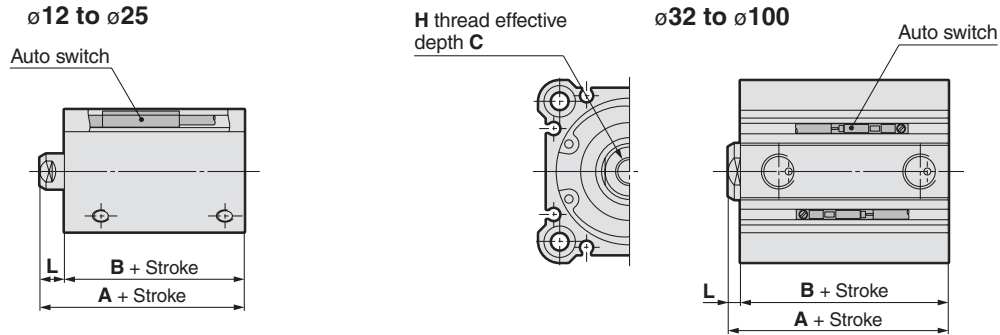

Symbol	ø12		ø20		ø32		ø40		ø50		ø63		ø80		ø100															
	Bore size	Stroke (mm)	Bore size	Stroke (mm)	Bore size	Stroke (mm)	Bore size	Stroke (mm)	Bore size	Stroke (mm)	Bore size	Stroke (mm)	Bore size	Stroke (mm)	Bore size	Stroke (mm)														
A	36.5	15, 25	38.5	5, 10, 20, 30, 40, 50	43.5	15, 25, 35, 45	36.5	10, 20, 30, 40, 50, 75, 100	41.5	5, 15, 25, 35, 45	43	10, 20, 30, 40, 50, 75, 100	48	5, 15, 25, 35, 45	44	10, 20, 30, 40, 50, 75, 100	49	15, 25, 35, 45	49.5	10, 20, 30, 40, 50, 75, 100	54.5	15, 25, 35, 45	57	10, 20, 30, 40, 50, 75, 100	62	15, 25, 35, 45	66.5	10, 20, 30, 40, 50, 75, 100	71.5	15, 25, 35, 45
B	33		31.5		36.5		33		38		39.5		44.5		40.5		45.5		46		51		53.5		58.5		63		68	
L	3.5		7		7		3.5		3.5		3.5		3.5		3.5		3.5		3.5		3.5		3.5		3.5		3.5		3.5	
H	M3 x 0.5		M5 x 0.8		M6 x 1.0*		M6 x 1.0*		M8 x 1.25*		M10 x 1.5		M16 x 2.0		M20 x 2.5															
C	6		7		9*		11*		13*		15		21		27															

* The H/C dimensions of ø32, ø40 and ø50 are different from those of the new CQ2 series model.

Double acting: Rod end male thread

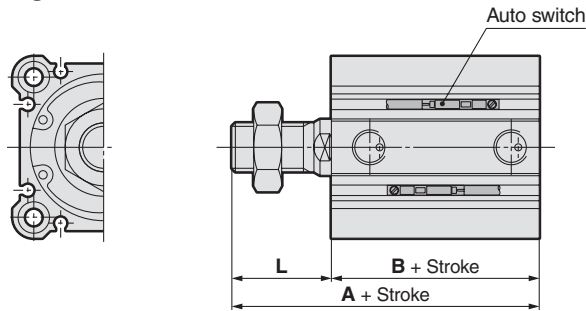

Symbol	ø12		ø20		ø32	ø40	ø50	ø63	ø80	ø100
	Bore size	Stroke (mm)	Bore size	Stroke (mm)	Bore size	Stroke (mm)	Bore size	Stroke (mm)	Bore size	Stroke (mm)
A	47	15, 25	53.5	5, 10, 20, 30, 40, 50	58.5	5, 15, 25, 35, 45	66.5	5, 15, 25, 35, 45	73	15, 25, 35, 45
B	33		31.5		36.5		38		44.5	
L	14		22		22		28.5		28.5	

- Standard
- Single Acting
- Double Rod
- Axial Piping
- Water Resistant
- High Lateral Load
- End Lock
- Clean Series
- Copper/Fluorine free series
- Construction and Parts
- Warranty and Operating Instructions
- Mounting and Auto Switches
- Made to Order

Series (N)CQ2 Made to Order Individual Specifications 3

Please contact SMC for detailed dimensions, specifications, and lead times.



Symbol

-X203 L Dimension from Rod Cover is the Same as the CQ1 Series.

C□Q2 Mounting Bore size — 10 Action Option Z — X203

In a single rod cylinder of the CQ2 series, the L dimension (from the rod face to the rod end) and the rod end female thread size are the same as the CQ1 series (former model).

Applicable Model

Action		Note	
Single rod	Female thread	Double acting Rubber bumper	Applicable to $\phi 20$, $\phi 32$, ($\phi 40$), ($\phi 50$), ($\phi 63$), ($\phi 80$), ($\phi 100$)
		Single acting (Spring return, Spring extend)	Applicable to $\phi 20$, $\phi 32$, ($\phi 40$), ($\phi 50$)
	Male thread	Available as the standard, CQ2 series	

Note 1) $\phi 16$ and $\phi 25$ are the new models so that they are not applicable.
Note 2) (): Same dimensions as for those of -X202

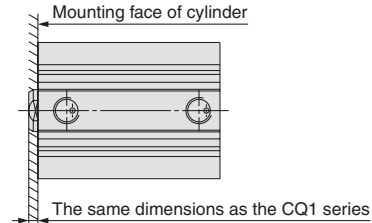

The specifications are the same as those of the standard, CQ2 series.

Dimensions: Applicable to CQ2B²⁰/₃₂-10D(C)Z Only

Double acting, Single rod

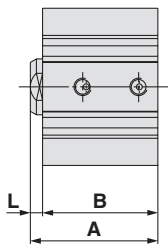

Symbol	Bore size	
	$\phi 20$	$\phi 32$
A	33	36.5
B	29.5	33
L	3.5	3.5

Single acting, Spring return

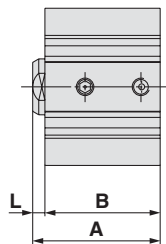

Symbol	Bore size	
	$\phi 20$	$\phi 32$
A	33	36.5
B	29.5	33
L	3.5	3.5

Single acting, Spring extend

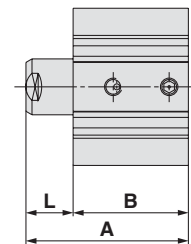

Symbol	Bore size	
	$\phi 20$	$\phi 32$
A	43	46.5
B	29.5	33
L	13.5	13.5

With Auto Switch: Applicable to CDQ2B-□D(C)Z Only

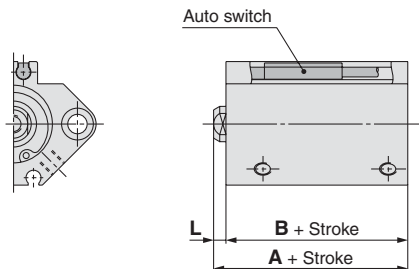

Symbol	Bore size	
	$\phi 20$	$\phi 32$
A	35	40
B	31.5	36.5
L	3.5	3.5

Symbol

-X235 Special Rod End for Double Rod Cylinder

Male thread is used at one piston rod end of double rod cylinder and female thread is used at the other end.

C□Q2W **Mounting** **Bore size** — **Stroke** **D** (Z) — **X235**

“D” in the case of “-X235” ●

● Piston rod end
Male thread, Female thread

* Specifications: Same as standard
Note) For mounting a bracket, please contact SMC.

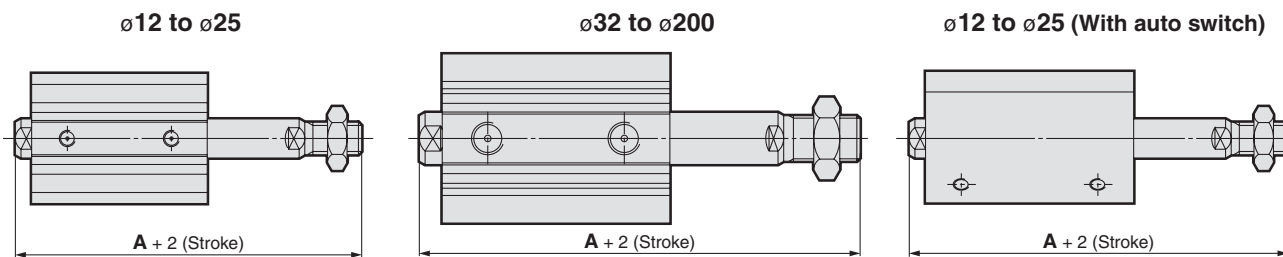

Symbol	Bore size	12	16	20	25	32	40	50	63	80	100	125	140	160	180	200
A		42.7 (49.9)	45 (55)	49 (61)	56.5 (66.5)	66 (76)	75.5 (85.5)	82 (92)	83.5 (93.5)	104.5 (114.5)	116 (126)	157	157	172	183	190
Applicable stroke		5 to 30		5 to 50		5 to 100			10 to 100			10 to 300				

Note 1) Applicable stroke: Available in 5 mm intervals

Note 2) (): Dimensions with auto switch

Symbol

-X271 Fluororubber Seals

Material for seals has been changed to fluororubber.

C□Q2 **Standard model no.** — **X271**

● Fluororubber seals ●

* All variations except non-rotating rod is available.
Only ø125 to ø160 is available for the large bore size type.
The specifications are the same as for each variation of the CQ2 series.
Note) With rubber bumper: There is no change of the bumper material.

- Standard
- Single Acting
- Double Rod
- Axial Piping
- Water Resistant
- High Lateral Load
- End Lock
- Clean Series
- Copper/Fluorine free series
- Construction and Parts
- Warranty and Operating Instructions
- Mounting and Auto Switches
- Made to Order

Series (N)CQ2 Made to Order Individual Specifications 4

Please contact SMC for detailed dimensions, specifications, and lead times.



Symbol

-X293 Full Length Dimension is the Same as the CQ1W Series.

C□Q2W Standard model no. — X293

The same dimensions as the CQ1W

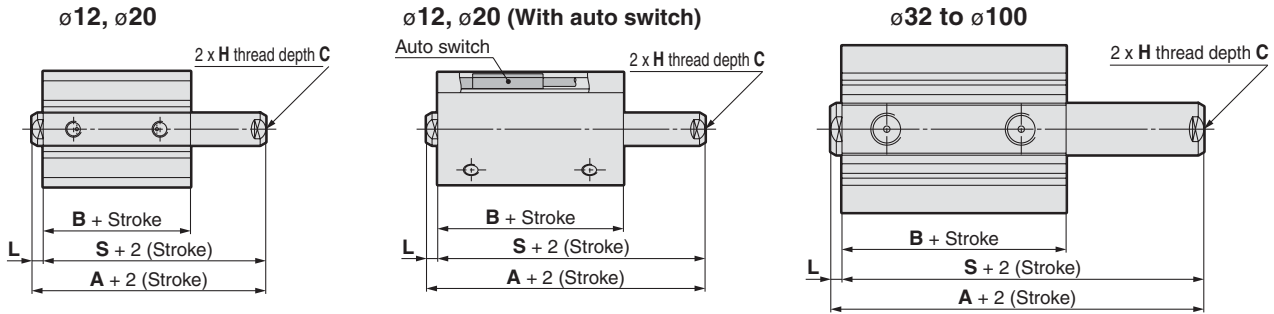

Without Auto Switch

Symbol	12		20		32		40		50		63		80		100	
	Stroke (mm)	Stroke (mm)	Stroke (mm)	Stroke (mm)	Stroke (mm)	Stroke (mm)	Stroke (mm)	Stroke (mm)	Stroke (mm)	Stroke (mm)	Stroke (mm)	Stroke (mm)	Stroke (mm)	Stroke (mm)	Stroke (mm)	Stroke (mm)
A	33	33	38	37	38	43	46.5	51.5	47.5	52.5	53	58	60.5	65.5	70	75
B	25.2	26	31	30.5	30.5	35.5	40	45	40.5	45.5	42	47	51	56	60.5	65.5
L	3.5	3.5	3.5	3.5	3.5	3.5	3.5	3.5	3.5	3.5	3.5	3.5	3.5	3.5	3.5	3.5
S	29.5	29.5	34.5	33.5	34.5	39.5	43	48	44	49	49.5	54.5	57	62	66.5	71.5
H	M3 x 0.5	M5 x 0.8	M5 x 0.8	M6 x 1	M6 x 1	M6 x 1	M6 x 1	M6 x 1	M8 x 1.25	M8 x 1.25	M10 x 1.5	M10 x 1.5	M16 x 2	M16 x 2	M20 x 2.5	M20 x 2.5
C	6	7	7	9	9	9	9	9	13	13	15	15	21	21	27	27

With Auto Switch

Symbol	12		20		32		40		50		63		80		100	
	Stroke (mm)	Stroke (mm)	Stroke (mm)	Stroke (mm)	Stroke (mm)	Stroke (mm)	Stroke (mm)	Stroke (mm)	Stroke (mm)	Stroke (mm)	Stroke (mm)	Stroke (mm)	Stroke (mm)	Stroke (mm)	Stroke (mm)	Stroke (mm)
A	40	47	52	48	53	56.5	61.5	57.5	62.5	63	68	70.5	75.5	80	85	
B	32.4	38	43	40.5	45.5	50	55	50.5	55.5	52	57	61	66	70.5	75.5	
L	3.5	3.5	3.5	3.5	3.5	3.5	3.5	3.5	3.5	3.5	3.5	3.5	3.5	3.5	3.5	
S	36	43.5	48.5	44.5	49.5	53	58	54	59	59.5	64.5	67	72	76.5	81.5	
H	M3 x 0.5	M5 x 0.8	M5 x 0.8	M6 x 1	M6 x 1	M6 x 1	M6 x 1	M8 x 1.25	M8 x 1.25	M10 x 1.5	M10 x 1.5	M16 x 2	M16 x 2	M20 x 2.5	M20 x 2.5	
C	6	7	7	9	9	9	9	13	13	15	15	21	21	27	27	

Symbol

-X525 Long Stroke of Adjustable Extension Stroke Cylinder (-XC8)

C□Q2 **Mounting** **Bore size** — **Stroke** **D(M)(Z)** — **X525**

• Long stroke of -XC8

The specifications are the same as those of -XC8 of the CQ2 series. Refer to "Made to Order."

Note) For tap mounting (ø12 to ø25—without switch) and bracket mounting, please contact SMC.

ø12 to ø25 (Without auto switch)

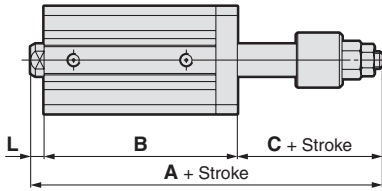

ø12 to ø25 (With auto switch)

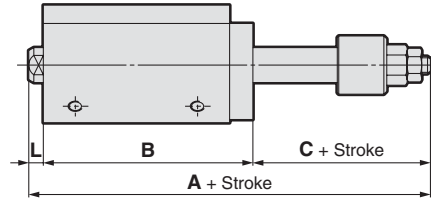

ø32 to ø100

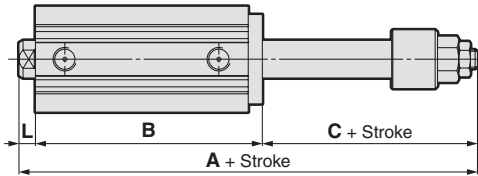

ø12, ø16

Bore size	Symbol Stroke	A				B				C	L	Applicable stroke
		35st	40st	45st	50st	35st	40st	45st	50st			
12		99.9	104.9	109.9	114.9	72.4	77.4	82.4	87.4	24	3.5	35, 40
16		104.5	109.9	114.9	119.5	77	82	87	92	24	3.5	45, 50

ø20 to ø100

Bore size	Symbol Stroke	A						B						C	L	Applicable stroke
		55 to 75st	80 to 100st	105 to 125st	130 to 150st	155 to 175st	180 to 200st	55 to 75st	80 to 100st	105 to 125st	130 to 150st	155 to 175st	180 to 200st			
20		155.5	180.5	—	—	—	—	122	147	—	—	—	—	29	4.5	55 to 100
25		156	181	—	—	—	—	122	147	—	—	—	—	29	5	
32		—	—	213.5	238.5	263.5	288.5	—	—	171.5	196.5	221.5	246.5	35	7	55 to 200
40		—	—	223	248	273	298	—	—	181	206	231	256	35	7	
50		—	—	235.5	260.5	285.5	310.5	—	—	183.5	208.5	233.5	258.5	44	8	
63		—	—	237	262	287	312	—	—	187	212	237	262	42	8	
80		—	—	260	285	310	335	—	—	198	223	248	273	52	10	
100		—	—	273.5	298.5	323.5	348.5	—	—	209.5	234.5	259.5	284.5	52	12	

Note 1) The dimensions are the same with or without auto switch.
 Note 2) Applicable stroke: Available in 5 mm intervals

- Standard
- Single Acting
- Double Rod
- Axial Piping
- Water Resistant
- High Lateral Load
- End Lock
- Clean Series
- Copper/Fluorine free series
- Construction and Parts
- Warranty and Operating Instructions
- Mounting and Auto Switches
- Made to Order

Series (N)CQ2 Made to Order Individual Specifications 5

Please contact SMC for detailed dimensions, specifications, and lead times.



Symbol

-X526 Long Stroke of Adjustable Retraction Stroke Cylinder (-XC9)

C□Q2 **Mounting** **Bore size** — **Stroke** D(M)(Z) — X526

Long stroke of -XC9

The specifications are the same as those of -XC9 of the CQ2 series. Refer to "Made to Order."

Note) For models with a bracket, please contact SMC.

Dimensions

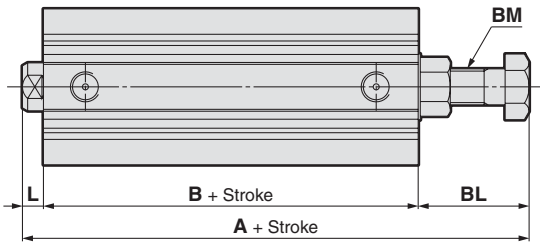

Symbol Bore size	A	B	L	BL	BM	Applicable stroke
12	59.2 (56.4)	32.4	3.5	23.3 (20.5)	M5 x 0.8	35, 40, 45, 50
16	64	37	3.5	23.5	M6 x 1.0	
20	74	39	4.5	30.5	M8 x 1.25	75, 100
25	73.5	39	5	29.5	M8 x 1.25	
32	75.5	40.5	7	28	M8 x 1.25	75, 100, 125
40	94	50	7	37	M12 x 1.5	
50	94.5	50.5	8	36	M12 x 1.5	
63	98.5	52	8	38.5	M16 x 1.5	150, 175, 200
80	119.5	91	10	48.5	M20 x 1.5	
100	135	70.5	12	52.5	M24 x 1.5	

Note 1) (): Dimensions with auto switch

Note 2) Intermediate strokes (available in 5 mm intervals) are available with a spacer.

The dimensions are the same as those of 75, 100, 125, 150, 175, 200 mm strokes.

Symbol

-X633 Intermediate Stroke of Double Rod Cylinder

C□Q2W **Standard model no.** — X633
C□Q2KW

* Specifications: Same as standard

Note) For models with a bracket, please contact SMC.

Dimensions

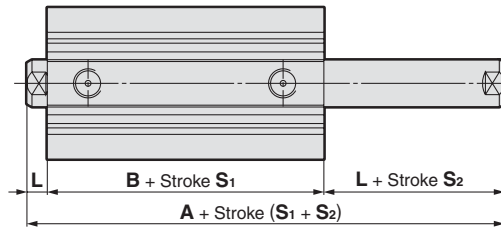

Bore size	Symbol	A	B	L	Stroke S1	Stroke S2
12		32.2 (39.4)	25.2 (32.4)	3.5	In the case of 5 to 30 stroke, 5 mm intervals	In the case of 5 to 30 stroke, 1 mm intervals
16		33 (43)	26 (36)	3.5		
20		35 (47)	26 (38)	4.5	In the case of 5 to 50 stroke, 5 mm intervals	In the case of 5 to 50 stroke, 1 mm intervals
25		39 (49)	29 (39)	5		
32		44.5 (54.5)	30.5 (40.5)	7	In the case of 5 to 50 stroke, 5 mm intervals	In the case of 5 to 100 stroke, 1 mm intervals
40		54 (64)	40 (50)	7	In the case of 50 to 100 stroke, 25 mm intervals	
50		56.5 (66.5)	40.5 (50.5)	8		
63		58 (68)	42 (52)	8	In the case of 10 to 50 stroke, 5 mm intervals	In the case of 10 to 100 stroke, 1 mm intervals
80		71 (81)	51 (61)	10	In the case of 50 to 100 stroke, 25 mm intervals	
100		84.5 (94.5)	60.5 (70.5)	12		
125		115	83	16	In the case of 10 to 50 stroke, 10 mm intervals	
140		115	83	16		
160		125	91	17	In the case of 50 to 200 stroke, 25 mm intervals	In the case of 10 to 300 stroke, 1 mm intervals
180		136	102	17		
200		143	109	17	In the case of 200 to 300 stroke, 50 mm intervals	

Note 1) (): Dimensions with auto switch

Note 2) Installing a spacer inside the standard cylinder tube, stroke S1 has 5 mm intervals for controlling intermediate strokes in 1 mm intervals.

Example) In the case of CDQ2WB40-18DZ, stroke S1 is 20 mm and stroke S2 is 18 mm.

Note 3) For ø40 to ø100 cylinders with bumper, please consult with SMC.

Symbol

-X636 Long Stroke of Dual Stroke Single Rod Cylinder

C□Q2B **Bore size** - **Stroke S₁** + **Stroke S₂-S₁** (C)(M)(Z) - X636

Long stroke of -XC11

Applicable Stroke (mm)

Bore size	Stroke
ø12, ø16	Stroke S ₂ : Up to 50 mm
ø20 to ø100	Stroke S ₂ : Up to 100 mm

The specifications are the same as those of -XC11 of the CQ2 series. Refer to "Made to Order."
Note) For tap mounting and bracket mounting, please contact SMC.

Series CQ2

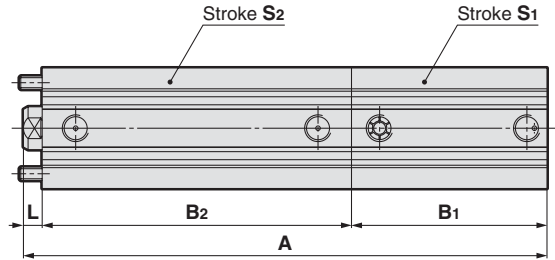

Bore Size: ø12, ø16 (mm)

Symbol Bore size	A	B ₁	B ₂	L	Stroke range	
					S ₁	S ₂
ø12	52.9 (63.9) + Stroke (S ₁ + S ₂)	17 (28) + Stroke S ₁	32.4 + Stroke S ₂	3.5	5 to 30	35 to 50
ø16	58 (70) + Stroke (S ₁ + S ₂)	18.5 (30.5) + Stroke S ₁	36 + Stroke S ₂	3.5	5 to 30	35 to 50

Bore Size: ø20, ø25 (mm)

Symbol Bore size	A		B ₁	B ₂		L	Stroke range	
	Stroke S ₂			Stroke S ₂			S ₁	S ₂
	Stroke S ₁	Stroke S ₂		Stroke S ₁	Stroke S ₂			
ø20	137 (149) + Stroke S ₁	80 to 100 162 (174) + Stroke S ₁	19.5 (31.5) + Stroke S ₁	55 to 75 113	80 to 100 138	4.5	5 to 50	55 to 100
ø25	141.5 (151.5) + Stroke S ₁	80 to 100 166.5 (176.5) + Stroke S ₁	22.5 (32.5) + Stroke S ₁	55 to 75 114	80 to 100 139	5	5 to 50	55 to 100

Bore Size: ø32 to ø100 (mm)

Symbol Bore size	A					B ₁			B ₂		L	Stroke range	
	Stroke S ₂ 55 to 75		Stroke S ₂ 80 to 100			Stroke S ₁			Stroke S ₂			S ₁	S ₂
	Stroke S ₁		Stroke S ₁			≤ 50	55 to 75	80 to 100	55 to 75	80 to 100			
	≤ 55	55 to 75	≤ 50	55 to 75	80 to 100								
ø32	145.4 (155.5) + Stroke S ₁	230.5	170.5 (180.5) + Stroke S ₁	255.5	280.5	23 (33) + Stroke S ₁	108	133	115.5	140.5	7	5 to 100	55 to 100
ø40	161.5 (171.5) + Stroke S ₁	246.5	186.5 (196.5) + Stroke S ₁	271.5	296.5	29.5 (39.5) + Stroke S ₁	114.5	139.5	125	150	7	5 to 100	55 to 100
ø50	164 (174) + Stroke S ₁	249	189 (199) + Stroke S ₁	274	299	30.5 (40.5) + Stroke S ₁	115.5	140.5	125.5	150.5	8	10 to 100	55 to 100
ø63	171 (181) + Stroke S ₁	256	196 (206) + Stroke S ₁	281	306	36 (46) + Stroke S ₁	121	146	127	152	8	10 to 100	55 to 100
ø80	189.5 (199.5) + Stroke S ₁	274.5	214.5 (224.5) + Stroke S ₁	299.5	324.5	43.5 (53.5) + Stroke S ₁	128.5	153.5	136	161	10	10 to 100	55 to 100
ø100	210.5 (220.5) + Stroke S ₁	295.5	235.5 (245.5) + Stroke S ₁	320.5	345.5	53 (63) + Stroke S ₁	138	163	145.5	170.5	12	10 to 100	55 to 100

Note 1) (): Dimensions with auto switch
Note 2) Applicable stroke: Available in 5 mm intervals

- Standard
- Single Acting
- Double Rod
- Axial Piping
- Water Resistant
- High Lateral Load
- End Lock
- Clean Series
- Copper/Fluorine free series
- Construction and Parts
- Warranty and Operating Instructions
- Mounting and Auto Switches
- Made to Order

Series (N)CQ2 Made to Order Individual Specifications 6

Please contact SMC for detailed dimensions, specifications, and lead times.



Symbol

-X1876 Cylinder Tube: With Concave Boss on Head End

C□Q2
C□Q2K
C□Q2□S

Mounting

Bore size

Stroke

D(C)(M)(Z)
S(M)(Z)
T(M)(Z)

- X1876

• With concave boss on head end

The specifications are the same as those of the CQ2 series.

Note) Except $\phi 12$, $\phi 16$ and $\phi 125$ to $\phi 200$

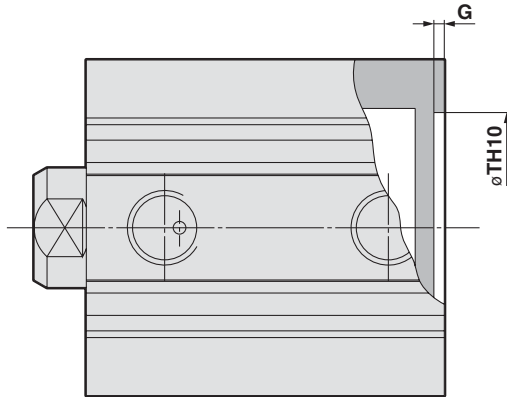

Bore size (mm)	TH10	G
20	19.3 ^{+0.084} ₀	1.4
25	23.8 ^{+0.084} ₀	1.4
32	30.9 ^{+0.100} ₀	1.4
40	39.3 ^{+0.100} ₀	1.3
50	48.7 ^{+0.100} ₀	2.1
63	61.5 ^{+0.120} ₀	2.4
80	78.3 ^{+0.120} ₀	3.3
100	98.9 ^{+0.140} ₀	2.8



SMC Corporation of America

Global Manufacturing, Distribution and Service Network

Worldwide Subsidiaries

EUROPE

AUSTRIA
SMC Pneumatik GmbH (Austria)

BELGIUM
SMC Pneumatics N.V./S.A.

BULGARIA
SMC Industrial Automation Bulgaria EOOD

CROATIA
SMC Industrijska Automatika d.o.o.

CZECH
SMC Industrial Automation CZ s.r.o.

DENMARK
SMC Pneumatik A/S

ESTONIA
SMC Pneumatics Estonia

FINLAND
SMC Pneumatics Finland OY

FRANCE
SMC Pneumatique S.A.

GERMANY
SMC Pneumatik GmbH

GREECE
SMC Hellas EPE

HUNGARY
SMC Hungary Ipari Automatizálási Kft.

IRELAND
SMC Pneumatics (Ireland) Ltd.

ITALY
SMC Italia S.p.A.

LATVIA
SMC Pneumatics Latvia SIA

LITHUANIA
SMC Pneumatics Lietuva, UAB

NETHERLANDS
SMC Pneumatics BV

NORWAY
SMC Pneumatics Norway A/S

POLAND
SMC Industrial Automation Polska Sp.z.o.o.

ROMANIA
SMC Romania S.r.l.

RUSSIA
SMC Pneumatik LLC.

SLOVAKIA
SMC Priemyselna Automatizacia, s.r.o.

SLOVENIA
SMC Industrijska Avtomatika d.o.o.

SPAIN / PORTUGAL
SMC España, S.A.

SWEDEN
SMC Pneumatics Sweden AB

SWITZERLAND
SMC Pneumatik AG

UK
SMC Pneumatics (U.K.) Ltd.

ASIA

CHINA
SMC (China) Co., Ltd.

HONG KONG
SMC Pneumatics (Hong kong) Ltd.

INDIA
SMC Pneumatics (India) Pvt. Ltd.

JAPAN
SMC Corporation

MALAYSIA
SMC Pneumatics (S.E.A.) Sdn. Bhd.

PHILIPPINES
SMC Pneumatics (Philippines), Inc.

SINGAPORE
SMC Pneumatics (S.E.A.) Pte. Ltd.

SOUTH KOREA
SMC Pneumatics Korea Co., Ltd.

TAIWAN
SMC Pneumatics (Taiwan) Co., Ltd.

THAILAND
SMC Thailand Ltd.

NORTH AMERICA

CANADA
SMC Pneumatics (Canada) Ltd.

MEXICO
SMC Corporation (Mexico) S.A. DE C.V.

USA
SMC Corporation of America

SOUTH AMERICA

ARGENTINA
SMC Argentina S.A.

BOLIVIA
SMC Pneumatics Bolivia S.R.L.

BRAZIL
SMC Pneumaticos do Brazil Ltda.

CHILE
SMC Pneumatics (Chile) S.A.

VENEZUELA
SMC Neumatica Venezuela S.A.

OCEANIA

AUSTRALIA
SMC Pneumatics (Australia) Pty. Ltd.

NEW ZEALAND
SMC Pneumatics (N.Z.) Ltd.

U.S. & Canadian Sales Offices

WEST

Austin
Dallas
Los Angeles
Phoenix
Portland
San Francisco
Vancouver

EAST

Atlanta
Birmingham
Boston
Charlotte
Nashville
New Jersey
Richmond
Rochester
Tampa
Montreal

CENTRAL

Chicago
Cincinnati
Cleveland
Detroit
Indianapolis
Milwaukee
Minneapolis
St. Louis
Toronto
Windsor

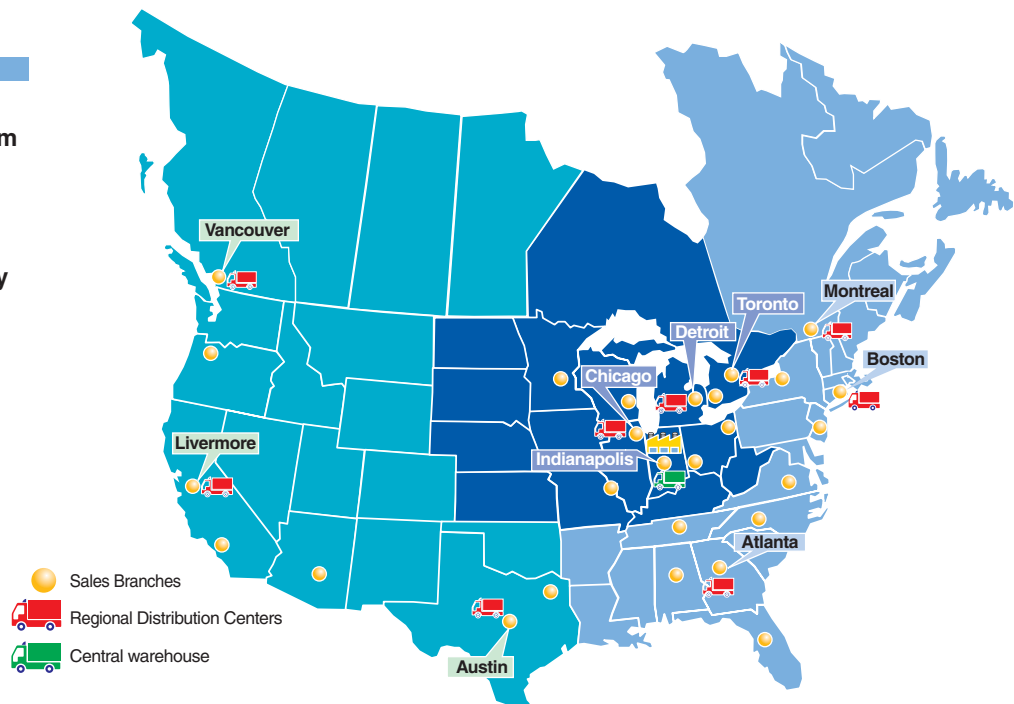

● Sales Branches
 Regional Distribution Centers
 Central warehouse

SMC Corporation of America
10100 SMC Blvd., Noblesville, IN 46060
www.smcusa.com

SMC Pneumatics (Canada) Ltd.
www.smcpcneumatics.ca

(800) SMC.SMC1 (762-7621)
e-mail: sales@smcusa.com
International inquiries: www.smcworld.com

