

DPR SERIES

32347489
Issue B

TruStability™ Board Mount Pressure Sensors Standard Accuracy, Compensated/Amplified ±1.6 mbar to ±25 mbar | ±160 Pa to ±2.5 kPa | ±0.5 H₂O to ±10 inH₂O

DESCRIPTION

The TruStability™ DPR Series is a piezoresistive silicon pressure sensor offering a ratiometric analog output for reading pressure over the specified full scale pressure span and temperature range. These sensors are fully calibrated and temperature compensated for sensor offset, sensitivity, temperature effects, and non-linearity using an on-board Application Specific Integrated Circuit (ASIC). Calibrated output values for pressure are updated at approximately 1 kHz. The DPR Series is calibrated over the temperature range of -20°C to 70°C [-4°F to 185°F]. The sensor is calibrated for operation from a single power supply of 5.0 Vdc. These sensors measure differential or gage pressures. The robust and durable housing, with its industry-standard mounting configuration, along with a choice of flexible electrical terminations, is designed to withstand tough application environments. The sensors' internal diagnostic functions detect most internal failures, including burst sensors, and may reduce the need for redundant sensors in the system. The DPR Series is intended for use with non-corrosive, non-ionic gases, such as air and other dry gases. Custom calibrations, additional pressure ranges or options to extend the performance of these sensors to include non-corrosive, non-ionic liquids is possible. All products are designed and manufactured according to ISO 9001 standards.

POTENTIAL INDUSTRIAL APPLICATIONS

- Heating, ventilation, air conditioning (HVAC)
- Variable air volume (VAV) control
- Damper control and duct air flow
- Filter monitoring/clogged filter detection
- Modulated furnace controls
- Indoor air quality
- Leak detection
- Pneumatic control
- Burner control
- Fuel-to-air rationing
- Gas analyzers and meters
- Fume hoods and clean rooms

FEATURES

- Pressure range: ±1.6 mbar to ±25 mbar | ±160 Pa to ±2.5 kPa | ±0.5 inH₂O to ±10 inH₂O
- Pressure types: Differential and gage
- Total Error Band: As low as ±1.25 %FSS depending on pressure range (after auto zero)
- Accuracy: ±0.25 %FSS BFSL (Full Scale Span Best Fit Straight Line)
- Stable offset voltage
- Compensated temperature range: -20°C to 70°C [-4°F to 158°F]
- Low sensitivity to mounting orientation
- Output: analog voltage
- Overvoltage and reverse polarity protected
- Industry-standard mounting configuration and barbed ports
- Robust and durable package
- Internal diagnostic functions
- RoHS compliant

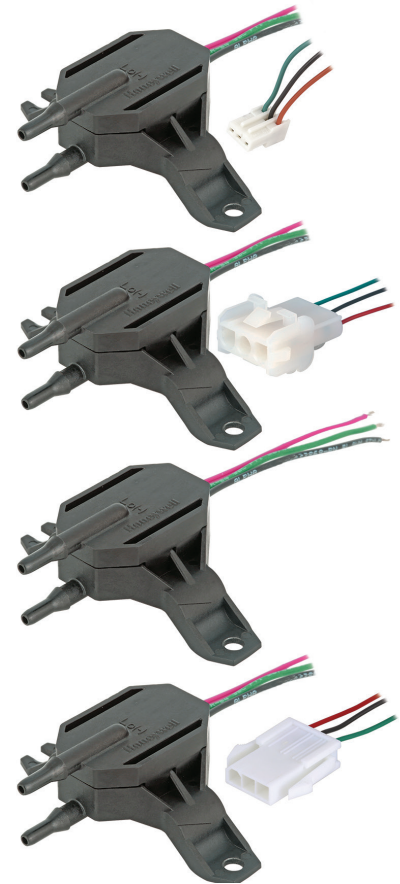

PORTFOLIO

Honeywell offers a variety of board mount pressure sensors for potential use in medical and industrial applications. Our categories of pressure sensor measurement include absolute, differential, gage or vacuum gage, with unamplified or amplified sensors and covering a wide pressure range. To view the entire product portfolio, [click here](#).

Honeywell

TRUSTABILITY™ BOARD MOUNT PRESSURE SENSORS, DPR SERIES

TABLE 1. ABSOLUTE MAXIMUM RATINGS¹

CHARACTERISTIC	MIN.	MAX.	UNIT
Supply voltage (V_{supply})	-5.0	12.0	Vdc
Voltage on output pin	-0.3	6.0	Vdc

¹Absolute maximum ratings are the extreme limits the device will withstand without damage.

TABLE 2. ENVIRONMENTAL SPECIFICATIONS

CHARACTERISTIC	PARAMETER
Humidity	0 %RH to 95 %RH, non-condensing
Vibration	15 g, 10 Hz to 2 kHz
Shock	100 g, 6 ms duration
ESD susceptibility	3 kV min, human body model
Life ¹	1 million pressure cycles minimum

¹ Life may vary depending on the specific application in which the sensor is utilized.

TABLE 3. WETTED MATERIALS¹

COMPONENT	MATERIAL	
	PORT 1 (PRESSURE PORT)	PORT 2 (REFERENCE PORT)
Ports and covers	high temperature polyamide	
Substrate	alumina ceramic	
Adhesives	epoxy, silicone	
O-Ring	silicone rubber	
Electronic components	ceramic, silicon, glass, solder	silicon, glass, gold

¹ Contact Honeywell Customer Service for detailed material information.

TABLE 4. SENSOR PRESSURE TYPES

PRESSURE TYPE	DESCRIPTION
Differential	Output is proportional to the difference between the pressures applied to each port (Port 1 - Port 2).
Gage	Output is proportional to the difference between applied pressure and atmospheric (ambient) pressure.

FIGURE 1. TEB COMPONENTS FOR TRUSTABILITY™ BOARD MOUNT PRESSURE SENSORS

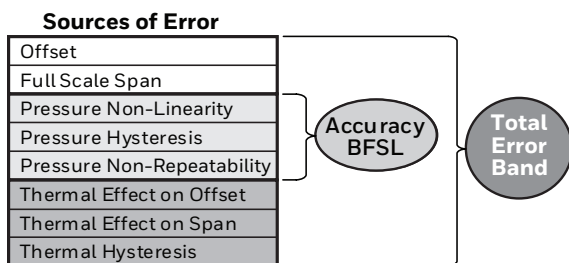
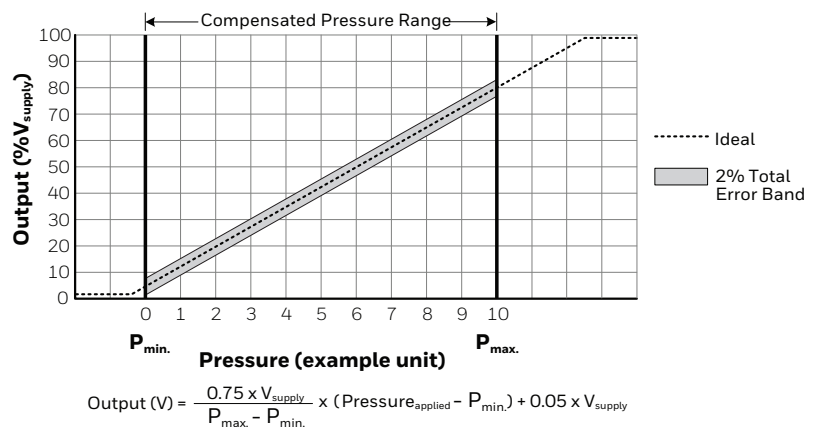

FIGURE 2. TRANSFER FUNCTION LIMITS



TRUSTABILITY™ BOARD MOUNT PRESSURE SENSORS, DPR SERIES

TABLE 5. OPERATING SPECIFICATIONS

CHARACTERISTIC	MIN.	TYP.	MAX.	UNIT
Supply voltage (V_{supply}) ¹	4.75	5.0	5.25	Vdc
Minimum operating voltage	3.0	—	—	Vdc
Supply current	—	2.7	3.5	mA
Operating temperature range ²	-40 [-40]	—	85 [185]	°C [°F]
Compensated temperature range ³	-20 [-4]	—	70 [158]	°C [°F]
Startup time (power up to data ready)	—	—	5	ms
Response time	—	1	—	ms
Clipping limits:				
upper	—	—	97.5	% V_{supply}
lower	2.5	—	—	
Accuracy ⁴	—	—	±0.25	%FSS BFSL ⁶
Output resolution	—	0.033	—	%FSS ⁶
Orientation sensitivity (± 1 g) ⁵ :				
≤ 40 mbar 4 kPa 20 inH ₂ O	—	±0.1	—	%FSS ⁶
≤ 2.5 mbar 250 Pa 1 inH ₂ O	—	±0.2	—	

¹Ratiometricity of the sensor (the ability of the device output to scale to the supply voltage) is achieved within the specified operating voltage.

²**Operating temperature range:** The temperature range over which the sensor will produce an output proportional to pressure.

³**Compensated temperature range:** The temperature range over which the sensor will produce an output proportional to pressure within the specified performance limits.

⁴**Accuracy:** The maximum deviation in output from a Best Fit Straight Line (BFSL) fitted to the output measured over the pressure range. Includes all errors due to pressure non-linearity, pressure hysteresis, and non-repeatability.

⁵**Orientation sensitivity:** The maximum change in offset of the sensor due to a change in position or orientation relative to Earth's gravitational field.

⁶**Full Scale Span (FSS):** The algebraic difference between the output signal measured at the maximum (P_{max}) and minimum (P_{min}) limits of the pressure range. (See Figure 3 for ranges).

TRUSTABILITY™ BOARD MOUNT PRESSURE SENSORS, DPR SERIES

TABLE 6. DPR SERIES AVAILABILITY¹

CATALOG LISTING	DESCRIPTION
DPRCAN0005NG0000A5	DPR Series, standard accuracy, compensated/amplified, flying leads with 304,8 mm harness length, no gel, 0 inH ₂ O to 5 inH ₂ O pressure range, analog output, 5% to 80% of V _{supply} transfer function, 5.0 Vdc supply voltage
DPRAN0005NG0000A5	DPR Series, standard accuracy, compensated/amplified, AMP 3-643814-3 connector with 304,8 mm harness length, no gel, 0 inH ₂ O to 5 inH ₂ O pressure range, analog output, 5% to 80% of V _{supply} transfer function, 5.0 Vdc supply voltage
DPRCAN0002NG0000A5	DPR Series, standard accuracy, compensated/amplified, flying leads with 304,8 mm harness length, no gel, 0 inH ₂ O to 2 inH ₂ O pressure range, analog output, 5% to 80% of V _{supply} transfer function, 5.0 Vdc supply voltage
DPRABN0005NG0000A5	DPR Series, standard accuracy, compensated/amplified, AMP 3-643814-3 connector with 50,8 mm harness length, no gel, 0 inH ₂ O to 5 inH ₂ O pressure range, analog output, 5% to 80% of V _{supply} transfer function, 5.0 Vdc supply voltage
DPRCAN0010NG0000A5	DPR Series, standard accuracy, compensated/amplified, flying leads with 304,8 mm harness length, no gel, 0 inH ₂ O to 10 inH ₂ O pressure range, analog output, 5% to 80% of V _{supply} transfer function, 5.0 Vdc supply voltage

¹These catalog listings are high volume and may be shipped quickly. Other configurations per Figure 3 are possible; however, minimum order quantity thresholds and NRE may apply. Please consult the factory.

FIGURE 3. NOMENCLATURE AND ORDER GUIDE

For example, **DPRCAN0002NG0000A5** defines a DPR Series, Standard Accuracy, Compensated/Amplified, flying leads, 304,8 mm harness length, no gel, 0 inH₂O to 2 inH₂O pressure range, analog output type, 5% to 80% of V_{supply} transfer function, 5.0 Vdc supply voltage.

Product Series
DPR Standard accuracy, compensated/amplified

Electrical Termination

- A** AMP 3-643814-3
- B** AMP 1-480701-0
- C** Flying leads
- D** Molex 39-01-4033

Harness Length

- A** 304,8 mm
- B** 50,8 mm

Gel

- N** No gel

D P R C A N 0 0 0 2 N G 0 0 0 0 A 5

Pressure Range

	P _{max.}	unit, reference	P _{min.}	
01.6MDN1.6	±1.6	mbar		02.5MG0000 0 mbar to 2.5 mbar
02.5MDN2.5	±2.5	mbar		0004MG0000 0 mbar to 4 mbar
0004MDN004	±4	mbar		0006MG0000 0 mbar to 6 mbar
0006MDN006	±6	mbar		0010MG0000 0 mbar to 10 mbar
0010MDN010	±10	mbar		0016MG0000 0 bar to 16 mbar
0016MDN016	±16	mbar		0025MG0000 0 bar to 25 mbar
0025MDN025	±25	mbar		0040MG0000 0 bar to 40 mbar
0160LDN160	±160	Pa		0250LG0000 0 Pa to 250 Pa
0250LDN250	±250	Pa		0400LG0000 0 Pa to 400 Pa
0400LDN400	±400	Pa		0600LG0000 0 Pa to 600 Pa
0600LDN600	±600	Pa		0001KG0000 0 kPa to 1 kPa
0001KDN001	±1	kPa		01.6KG0000 0 kPa to 1.6 kPa
01.6KDN1.6	±1.6	kPa		02.5KG0000 0 kPa to 2.5 kPa
02.5KDN2.5	±2.5	kPa		0004KG0000 0 kPa to 4 kPa
00.5NDN0.5	±0.5	inH ₂ O		0001NG0000 0 inH ₂ O to 1 inH ₂ O
0001NDN001	±1	inH ₂ O		0002NG0000 0 inH ₂ O to 2 inH ₂ O
0002NDN002	±2	inH ₂ O		0005NG0000 0 inH ₂ O to 5 inH ₂ O
0005NDN005	±5	inH ₂ O		0009NGN.75 -0.75 inH ₂ O to 9 inH ₂ O
0010NDN010	±10	inH ₂ O		0010NG0000 0 inH ₂ O to 10 inH ₂ O
				0014NGN.40 -0.40 inH ₂ O to 14 inH ₂ O
				0020NG0000 0 inH ₂ O to 20 inH ₂ O

Supply Voltage
5 5.0 Vdc

Transfer Function

- A** 5% to 80% of V_{supply} (analog output)
- B** 10% to 90% of V_{supply} (analog output)

TRUSTABILITY™ BOARD MOUNT PRESSURE SENSORS, DPR SERIES

TABLE 7. PRESSURE RANGE SPECIFICATIONS FOR ±1.6 MBAR TO ±25 MBAR DIFFERENTIAL AND 0 MBAR TO 2.5 BAR TO 0 MBAR TO 40 MBAR GAGE.

PRESSURE RANGE (SEE FIGURE 3.)	PRESSURE RANGE		UNIT	WORKING PRESSURE ¹	OVER PRESSURE ²	BURST PRESSURE ³	COMMON MODE PRESSURE ⁴	TOTAL ERROR BAND (%FSS) ⁵	TOTAL ERROR BAND AFTER AUTO-ZERO ⁶ (%FSS)	LONG-TERM STABILITY, 1000 HR 25°C (%FSS)
	Pmin.	Pmax.								
Differential										
01.6MDN1.6	-1.6	1.6	mbar	335	675	1000	3450	±3.5%	±2.5%	±0.5%
02.5MDN2.5	-2.5	2.5	mbar	335	675	1000	3450	±3%	±1.5%	±0.35%
0004MDN004	-4	4	mbar	335	675	1000	3450	±2.5%	±1.25%	±0.35%
0006MDN006	-6	6	mbar	335	675	1000	3450	±2%	±1.25%	±0.35%
0010MDN010	-10	10	mbar	375	750	1250	5450	±2%	±1.25%	±0.25%
0016MDN016	-16	16	mbar	375	750	1250	5450	±2%	±1.25%	±0.25%
0025MDN025	-25	25	mbar	435	850	1350	10450	±2%	±1.25%	±0.25%
Gage										
02.5MG0000	0	2.5	mbar	335	675	1000	3450	±4%	±3%	±0.5%
0004MG0000	0	4	mbar	335	675	1000	3450	±3%	±1.5%	±0.5%
0006MG0000	0	6	mbar	335	675	1000	3450	±3%	±1.5%	±0.35%
0010MG0000	0	10	mbar	335	675	1000	3450	±2%	±1.25%	±0.35%
0016MG0000	0	16	mbar	335	675	1000	3450	±2%	±1.25%	±0.25%
0025MG0000	0	25	mbar	375	750	1250	5450	±2%	±1.25%	±0.25%
0040MG0000	0	40	mbar	375	750	1250	5450	±2%	±1.25%	±0.25%

¹**Working Pressure:** The maximum pressure that may be applied to any port of the sensor in continuous use. This pressure may be outside the operating pressure range limits (Pmin. to Pmax.) in which case the sensor may not provide a valid output until pressure is returned to within the operating pressure range. Tested to 1 million cycles, minimum.

²**Overpressure:** The maximum pressure which may safely be applied to the product for it to remain in specification once pressure is returned to the operating pressure range. Exposure to higher pressures may cause permanent damage to the product. Unless otherwise specified, this applies to all available pressure ports at any temperature within the operating temperature range

³**Burst pressure:** The maximum pressure that may be applied to any port of the product without causing escape of pressure media. Product should not be expected to function after exposure to any pressure beyond the burst pressure.

⁴**Common mode pressure:** The maximum pressure that can be applied simultaneously to both ports of a differential pressure sensor without causing changes in specified performance.

⁵**Total Error Band:** The maximum deviation from the ideal transfer function over the entire compensated temperature and pressure range. Includes all errors due to offset, full scale span, pressure non-linearity, pressure hysteresis, repeatability, thermal effect on offset, thermal effect on span, and thermal hysteresis (see Figure 1).

⁶**Total Error Band after Auto-Zero:** The maximum deviation from the ideal transfer function over the entire compensated pressure range at a constant temperature and supply voltage for a minimum of 24 hours after an auto-zero operation. Includes all errors due to full scale span, pressure non-linearity, pressure hysteresis, and thermal effect on span.

TRUSTABILITY™ BOARD MOUNT PRESSURE SENSORS, DPR SERIES

TABLE 8. PRESSURE RANGE SPECIFICATIONS FOR ±160 PA TO ±2.5 KPA DIFFERENTIAL AND 0 PA TO 250 PA TO 0 PA TO 4 KPA GAGE

PRESSURE RANGE (SEE FIGURE 3.)	PRESSURE RANGE		UNIT	WORKING PRESSURE ¹	OVER PRESSURE ²	BURST PRESSURE ³	COMMON MODE PRESSURE ⁴	TOTAL ERROR BAND (%FSS) ⁵	TOTAL ERROR BAND AFTER AUTO-ZERO ⁶ (%FSS)	LONG-TERM STABILITY, 1000 HR 25°C (%FSS)
	P _{MIN.}	P _{MAX.}								
Differential										
0160LDN160	-160	160	Pa	33500	67500	100000	345000	±3.5%	±2.5%	±0.5%
0250LDN250	-250	250	Pa	33500	67500	100000	345000	±3%	±1.5%	±0.35%
0400LDN400	-400	400	Pa	33500	67500	100000	345000	±2.5%	±1.25%	±0.35%
0600LDN600	-600	600	Pa	33500	67500	100000	34500	±2%	±1.25%	±0.35%
0001KDN001	-1	1	kPa	37.5	75	125	545	±2%	±1.25%	±0.25%
01.6KDN1.6	-1.6	1.6	kPa	37.5	75	125	545	±2%	±1.25%	±0.25%
02.5KDN2.5	-2.5	2.5	kPa	43.5	85	135	1045	±2%	±1.25%	±0.25%
Gage										
0250LG0000	0	250	Pa	33500	67500	100000	345000	±4%	±3%	±0.5%
0400LG0000	0	400	Pa	33500	67500	100000	345000	±3%	±1.5%	±0.5%
0600LG0000	0	600	Pa	33500	67500	100000	345000	±3%	±1.5%	±0.35%
0001KG0000	0	1	kPa	33.5	67.5	100	345	±2%	±1.25%	±0.35%
01.6KG0000	0	1.6	kPa	33.5	67.5	100	345	±2%	±1.25%	±0.25%
02.5KG0000	0	2.5	kPa	37.5	75	125	545	±2%	±1.25%	±0.25%
0004KG0000	0	4	kPa	37.5	75	125	545	±2%	±1.25%	±0.25%

- ¹**Working Pressure:** The maximum pressure that may be applied to any port of the sensor in continuous use. This pressure may be outside the operating pressure range limits (P_{min.} to P_{max.}) in which case the sensor may not provide a valid output until pressure is returned to within the operating pressure range. Tested to 1 million cycles, minimum.
- ²**Overpressure:** The maximum pressure which may safely be applied to the product for it to remain in specification once pressure is returned to the operating pressure range. Exposure to higher pressures may cause permanent damage to the product. Unless otherwise specified, this applies to all available pressure ports at any temperature within the operating temperature range
- ³**Burst pressure:** The maximum pressure that may be applied to any port of the product without causing escape of pressure media. Product should not be expected to function after exposure to any pressure beyond the burst pressure.
- ⁴**Common mode pressure:** The maximum pressure that can be applied simultaneously to both ports of a differential pressure sensor without causing changes in specified performance.
- ⁵**Total Error Band:** The maximum deviation from the ideal transfer function over the entire compensated temperature and pressure range. Includes all errors due to offset, full scale span, pressure non-linearity, pressure hysteresis, repeatability, thermal effect on offset, thermal effect on span, and thermal hysteresis (see Figure 1).
- ⁶**Total Error Band after Auto-Zero:** The maximum deviation from the ideal transfer function over the entire compensated pressure range at a constant temperature and supply voltage for a minimum of 24 hours after an auto-zero operation. Includes all errors due to full scale span, pressure non-linearity, pressure hysteresis, and thermal effect on span.

TRUSTABILITY™ BOARD MOUNT PRESSURE SENSORS, DPR SERIES

TABLE 9. PRESSURE RANGE SPECIFICATIONS FOR ±0.5 INH₂O TO ±10 INH₂O DIFFERENTIAL AND 0 ±0 INH₂O TO 20 INH₂O GAGE

PRESSURE RANGE (SEE FIGURE 3.)	PRESSURE RANGE		UNIT	WORKING PRESSURE ¹	OVER PRESSURE ²	BURST PRESSURE ³	COMMON MODE PRESSURE ⁴	TOTAL ERROR BAND (%FSS) ⁵	TOTAL ERROR BAND AFTER AUTO-ZERO ⁶ (%FSS)	LONG-TERM STABILITY, 1000 HR 25°C (%FSS)
	P _{MIN.}	P _{MAX.}								
Differential										
00.5NDN0.5	-0.5	0.5	inH ₂ O	135	270	415	1400	±4%	±3%	±0.5%
0001NDN001	-1	1	inH ₂ O	135	270	415	1400	±3%	±1.5%	±0.35%
0002NDN002	-2	2	inH ₂ O	135	270	415	1400	±2%	±1.25%	±0.35%
0005NDN005	-5	5	inH ₂ O	150	300	500	2200	±2%	±1.25%	±0.25%
0010NDN010	-10	10	inH ₂ O	175	350	500	4200	±2%	±1.25%	±0.25%
Gage										
0001NG0000	0	1	inH ₂ O	135	270	415	1400	±4%	±3%	±0.5%
0002NG0000	0	2	inH ₂ O	135	270	415	1400	±3%	±1.5%	±0.35%
0005NG0000	0	5	inH ₂ O	135	270	415	1400	±2%	±1.25%	±0.25%
0009NGN.75	-0.75	9	inH ₂ O	135	270	415	1400	±2%	±1.25%	±0.25%
0010NG0000	0	10	inH ₂ O	150	300	500	2200	±2%	±1.25%	±0.25%
0014NGN.40	-0.40	14	inH ₂ O	150	300	500	2200	±2%	±1.25%	±0.25%
0020NG0000	0	20	inH ₂ O	175	350	550	4200	±2%	±1.25%	±0.25%

- ¹**Working Pressure:** The maximum pressure that may be applied to any port of the sensor in continuous use. This pressure may be outside the operating pressure range limits (P_{min.} to P_{max.}) in which case the sensor may not provide a valid output until pressure is returned to within the operating pressure range. Tested to 1 million cycles, minimum.
- ²**Overpressure:** The maximum pressure which may safely be applied to the product for it to remain in specification once pressure is returned to the operating pressure range. Exposure to higher pressures may cause permanent damage to the product. Unless otherwise specified, this applies to all available pressure ports at any temperature within the operating temperature range
- ³**Burst pressure:** The maximum pressure that may be applied to any port of the product without causing escape of pressure media. Product should not be expected to function after exposure to any pressure beyond the burst pressure.
- ⁴**Common mode pressure:** The maximum pressure that can be applied simultaneously to both ports of a differential pressure sensor without causing changes in specified performance.
- ⁵**Total Error Band:** The maximum deviation from the ideal transfer function over the entire compensated temperature and pressure range. Includes all errors due to offset, full scale span, pressure non-linearity, pressure hysteresis, repeatability, thermal effect on offset, thermal effect on span, and thermal hysteresis (see Figure 1).
- ⁶**Total Error Band after Auto-Zero:** The maximum deviation from the ideal transfer function over the entire compensated pressure range at a constant temperature and supply voltage for a minimum of 24 hours after an auto-zero operation. Includes all errors due to full scale span, pressure non-linearity, pressure hysteresis, and thermal effect on span.

TRUSTABILITY™ BOARD MOUNT PRESSURE SENSORS, DPR SERIES

FIGURE 4. NOMENCLATURE AND ORDER GUIDE

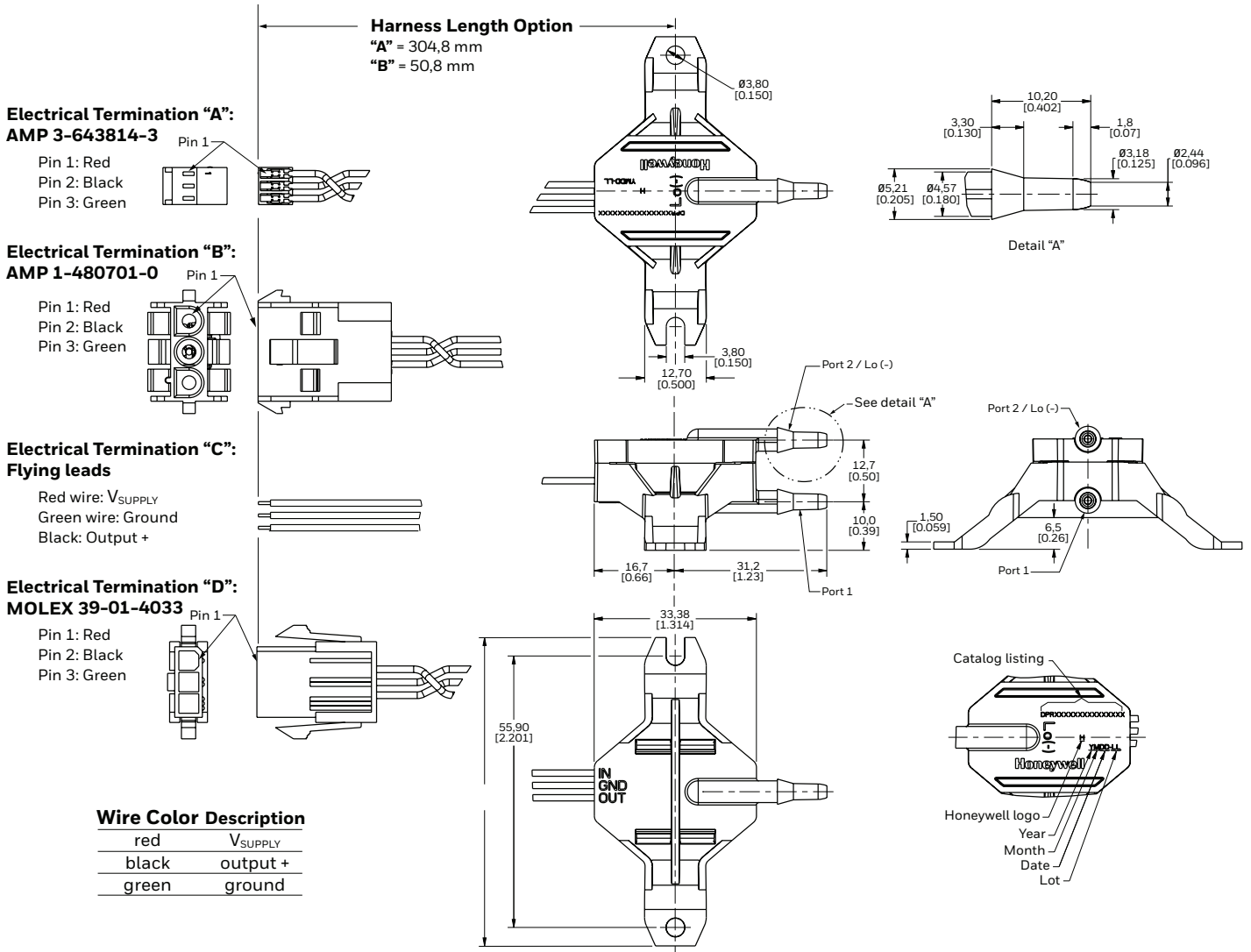

ADDITIONAL MATERIALS

The following associated literature is available at sensing.honeywell.com:

- Product range guide
- Installation instructions
- CAD Models

WARRANTY/REMEDY

Honeywell warrants goods of its manufacture as being free of defective materials and faulty workmanship during the applicable warranty period. Honeywell's standard product warranty applies unless agreed to otherwise by Honeywell in writing; please refer to your order acknowledgment or consult your local sales office for specific warranty details. If warranted goods are returned to Honeywell during the period of coverage, Honeywell will repair or replace, at its option, without charge those items that Honeywell, in its sole discretion, finds defective.

The foregoing is buyer's sole remedy and is in lieu of all other warranties, expressed or implied, including those of merchantability and fitness for a particular purpose. In no event shall Honeywell be liable for consequential, special, or indirect damages.

While Honeywell may provide application assistance personally, through our literature and the Honeywell web site, it is buyer's sole responsibility to determine the suitability of the product in the application.

Specifications may change without notice. The information we supply is believed to be accurate and reliable as of this writing. However, Honeywell assumes no responsibility for its use.

FOR MORE INFORMATION

Honeywell Sensing and Internet of Things services its customers through a worldwide network of sales offices and distributors. For application assistance, current specifications, pricing or the nearest Authorized Distributor, visit sensing.honeywell.com or call:

Asia Pacific +65 6355-2828
Europe +44 1698 481481
USA/Canada +1-302-613-4491

Honeywell Sensing and Internet of Things

9680 Old Bailes Road
Fort Mill, SC 29707
www.honeywell.com

WARNING **PERSONAL INJURY**

DO NOT USE these products as safety or emergency stop devices or in any other application where failure of the product could result in personal injury.

Failure to comply with these instructions could result in death or serious injury.

WARNING **MISUSE OF** **DOCUMENTATION**

- The information presented in this product sheet is for reference only. Do not use this document as a product installation guide.
- Complete installation, operation, and maintenance information is provided in the instructions supplied with each product.

Failure to comply with these instructions could result in death or serious injury.