

# 5 Port Solenoid Valve

## VFR2000/3000/4000/5000/6000 Series

Rubber Seal



### Series Variations

\* 2 position single type  
Passage: 4/2 → 5/3 (A/B → EA/EB)

Series	Sonic conductance* C [dm <sup>3</sup> /(s·bar)]	Type of actuation	Voltage	Electrical entry	With light/surge voltage suppressor (Option)	Manual override	
Base Mounted	VFR2000 Plug-in type Non plug-in type  P.1018	1/8, 1/4: 3.0	2 position single VFR2000/3000/4000 	<b>Plug-in</b> Conduit terminal (F) <b>Non plug-in</b> Grommet (G) Conduit terminal (T) L plug connector (L) Grommet terminal (E) DIN terminal (D, Y) M plug connector (M)	<input type="checkbox"/> With light/surge voltage suppressor <ul style="list-style-type: none"> <li>Plug-in type Conduit terminal (FZ)</li> <li>Non plug-in type Grommet terminal (EZ) Conduit terminal (TZ) DIN terminal (DZ, YZ) L plug connector (LZ) M plug connector (MZ)</li> </ul> <input type="checkbox"/> With surge voltage suppressor <ul style="list-style-type: none"> <li>Non plug-in type Grommet (GS)</li> </ul> Note) Surge voltage suppressor is equipped midway on the lead wire for grommet type.		
		VFR3000 Plug-in type Non plug-in type  P.1038	1/4: 7.5 3/8: 8.7	2 position double VFR5000/6000 	(Standard) 100 VAC <sup>50</sup> / <sub>60</sub> Hz 200 VAC <sup>50</sup> / <sub>60</sub> Hz 24 VDC	<b>Plug-in</b> Conduit terminal (F) <b>Non plug-in</b> Grommet terminal (E) DIN terminal (D) <b>Non plug-in</b> Grommet (G) Conduit terminal (T) DIN terminal (D, Y) Grommet terminal (E)	<input type="checkbox"/> With light/surge voltage suppressor <ul style="list-style-type: none"> <li>Plug-in type Conduit terminal (FZ)</li> <li>Non plug-in type (VFR3□10/4□10) DIN terminal (DZ) Grommet terminal (EZ) Conduit terminal (TZ)</li> </ul> <input type="checkbox"/> With surge voltage suppressor <ul style="list-style-type: none"> <li>Non plug-in type (VFR3□40/4□40) Grommet (GS)</li> </ul> Note) Surge voltage suppressor is equipped midway on the lead wire for grommet type.
	VFR4000 Plug-in type Non plug-in type  P.1061	3/8, 1/2: 14	3 position closed center  3 position exhaust center 	(Semi-standard) 110 to 120 V <sup>50</sup> / <sub>60</sub> Hz 220 VAC <sup>50</sup> / <sub>60</sub> Hz 240 VAC <sup>50</sup> / <sub>60</sub> Hz 12 VDC	<b>Plug-in</b> Conduit terminal (F) <b>Non plug-in</b> Grommet terminal (E) DIN terminal (D) Conduit terminal (T) DIN terminal (D, Y) Grommet terminal (E)	<input type="checkbox"/> With surge voltage suppressor <ul style="list-style-type: none"> <li>Non plug-in type (VFR3□40/4□40) Grommet (GS)</li> </ul> Note) Surge voltage suppressor is equipped midway on the lead wire for grommet type.	
	VFR5000 Plug-in type Non plug-in type  P.1084	3/8: 18 1/2: 23 3/4: 25	3 position pressure center 		<b>Plug-in</b> Conduit terminal (F) <b>Non plug-in</b> Grommet terminal (E) DIN terminal (D)	<input type="checkbox"/> With light/surge voltage suppressor <ul style="list-style-type: none"> <li>Plug-in type Conduit terminal (FZ)</li> <li>Non plug-in type DIN terminal (DZ) Grommet terminal (EZ)</li> </ul>	
	VFR6000 Plug-in type Non plug-in type  P.1099	3/4: 41 1: (Effective area 191 mm <sup>2</sup> )			<b>Plug-in</b> Conduit terminal (F) <b>Non plug-in</b> Grommet terminal (E) DIN terminal (D)	<input type="checkbox"/> With light/surge voltage suppressor <ul style="list-style-type: none"> <li>Non plug-in type DIN terminal (DZ) Grommet terminal (EZ)</li> </ul>	Non-locking push type

SV
SYJ
SZ
VF
VP4
VQ 1/2
VQ 4/5
VQC 1/2
VQC 4/5
VQZ
SQ
VFS
VFR
VQ7



# VFR2000/3000/4000/5000/6000 Series

## Manifold Variations

		Base Mounted Plug-in Type			
		VFR2000 P.1026	VFR3000 P.1046	VFR4000 P.1069	VFR5000 P.1090
Manifold	With multi-connector				
	With terminal block				
	With D-sub connector				

Manifold Option Parts	Individual SUP spacer	●	●	●	●
	Individual EXH spacer	●	●	●	●
	SUP block disk	●	●	●	●
	EXH block disk	●	●	●	●
	Throttle valve spacer	●	●	●	●
	Interface regulator	●	●	●	●
	Blanking plate	●	●	●	●
	Air release valve spacer	●	●	●	
	SUP stop valve spacer	● <sup>(1)</sup>	●		

Note 1) Used with the manifold base. Please contact SMC for details.

Note 2) There is no manifold base in the VFR6000 series.

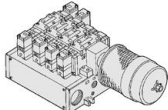
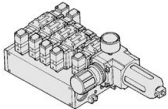
Manifold Option	 <p><b>With exhaust cleaner</b> Plug-in type, Non plug-in type</p> <ul style="list-style-type: none"> <li>• High noise reduction effect: 35 dB or more</li> <li>• Collects oil mist: collecting rate 99.9% or more</li> <li>• Piping work is reduced.</li> </ul>
	 <p><b>With control unit</b> <sup>Note)</sup> Plug-in type, Non plug-in type</p> <ul style="list-style-type: none"> <li>• Filter, regulator, pressure switch and air release valve in one unit</li> <li>• Piping work eliminated</li> </ul>

Note) There is no option with control unit in the VFR5000 series.

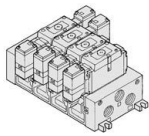
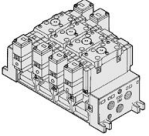
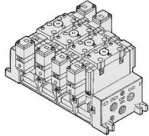
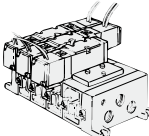
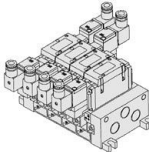
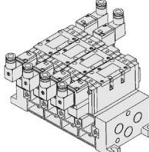
		Base Mounted Non Plug-in Type			
		VFR2000 P.1027	VFR3000 P.1047	VFR4000 P.1070	VFR5000 P.1091
<b>Manifold</b>	Common electrical entry • Grommet terminal • DIN terminal	—			
	Individual electrical entry • Grommet • Grommet terminal • Conduit terminal • DIN terminal • L plug connector (Note) • M plug connector (Note)				

Note) VFR2000 series only

<b>Manifold Option Parts</b>	Individual SUP spacer	●	●	●	●
	Individual EXH spacer	●	●	●	●
	SUP block disk	●	●	●	●
	EXH block disk	●	●	●	●
	Throttle valve spacer	●	●	●	●
	Interface regulator	●	●	●	●
	Blanking plate	●	●	●	●
	Air release valve spacer	●	●	●	
	SUP stop valve spacer	● <sup>(1)</sup>	●		

Note 1) Used with the manifold base. Please contact SMC for details.

Note 2) There is no manifold base in the VFR6000 series.

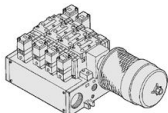
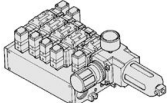
<b>Manifold Option</b>		<p><b>With exhaust cleaner</b> Plug-in type, Non plug-in type</p> <ul style="list-style-type: none"> <li>• High noise reduction effect: 35 dB or more</li> <li>• Collects oil mist: collecting rate 99.9% or more</li> <li>• Piping work is reduced.</li> </ul>
		<p><b>With control unit</b> (Note) Plug-in type, Non plug-in type</p> <ul style="list-style-type: none"> <li>• Filter, regulator, pressure switch and air release valve in one unit</li> <li>• Piping work eliminated</li> </ul>

Note) There is no option with control unit in the VFR5000 series.

- SV
- SYJ
- SZ
- VF
- VP4
- VQ 1/2
- VQ 4/5
- VQC 1/2
- VQC 4/5
- VQZ
- SQ
- VFS
- VFR
- VQ7

# 5 Port Pilot Operated Solenoid Valve Rubber Seal, Plug-in/Non Plug-in VFR2000 Series



[Option] Note



NRTL / C

Note) Applicable only for DIN terminal and plug-in types.  
For details, refer to "How to Order".

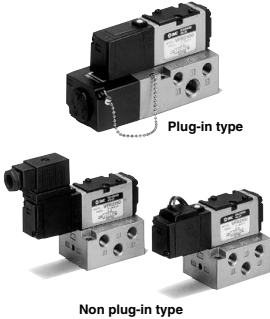

Plug-in type

Non plug-in type

## Symbol

2 position	3 position
Single	Closed center
(A)4 2(B) (EA)5 1 3(EB) (P)	(A)4 2(B) (EA)5 1 3(EB) (P)
Double	Exhaust center
(A)4 2(B) (EA)5 1 3(EB) (P)	(A)4 2(B) (EA)5 1 3(EB) (P)
	Pressure center
	(A)4 2(B) (EA)5 1 3(EB) (P)

## Standard Specifications

Valve specifications	Fluid	Air		
	Operating pressure range	2 position single/3 position	0.2 to 0.9 MPa	
		2 position double	0.1 to 0.9 MPa	
	Ambient and fluid temperature	-10 to 50°C (No freezing.)		
	Lubrication	Not required <sup>(1)</sup>		
	Manual override	Non-locking push type		
	Mounting orientation	Unrestricted		
Impact/Vibration resistance	300/50 m/s <sup>2</sup> <sup>(2)</sup>			
Enclosure	Dustproof			
Electricity specifications	Coil rated voltage	100, 200 VAC (50/60 Hz), 24 VDC		
	Allowable voltage fluctuation	-15 to -10% of rated voltage		
	Apparent power (AC) <sup>(3)</sup>	Inrush Holding	5.6 VA/50 Hz, 5.0 VA/60 Hz	
			3.4 VA (2.1 W)/50 Hz, 2.3 VA (1.5 W)/60 Hz	
	Power consumption (DC) <sup>(3)</sup>		1.8 W (2.04 W: With light/surge voltage suppressor)	
		Electrical entry	Plug-in type	Conduit terminal
	Non plug-in type	Grommet, Grommet terminal	Conduit terminal, DIN terminal	
			L plug connector, M plug connector	

Note 1) Use turbine oil Class 1 (ISO VG32), if lubricated.

Note 3) At rated voltage

Note 2) Impact resistance: No malfunction occurred when it is tested with a drop tester in the axial direction and at the right angles to the main valve and armature in both energized and de-energized states every once for each condition. (Values at the initial period)

Vibration resistance: No malfunction occurred in a one-sweep test between 45 and 2000 Hz.

Test was performed at both energized and de-energized states in the axial direction and at the right angles to the main valve and armature. (Values at the initial period)

## Option Specifications

Pilot type	External pilot <sup>Note)</sup>
Manual override	Non-locking push type A (Extended), Locking type B (Tool required), Locking type C (Lever)
Coil rated voltage	110 to 120, 220, 240 VAC 50/60 Hz 12 VDC
Porting specifications	Bottom ported
Option	With light/surge voltage suppressor

Note) Operating pressure: 0 to 0.9 MPa

Pilot pressure: 2 position single/3 position 0.2 to 0.9 MPa

2 position double 0.1 to 0.9 MPa

## Model

Type of actuation	Model		Port size Rc	Flow rate characteristics <sup>(1)</sup>						<sup>(2)</sup> Max. operating cycle (Hz)	<sup>(3)</sup> Response time (ms)	<sup>(4)</sup> Weight (kg)	
	Plug-in	Non plug-in		1 → 4/2 (P → A/B)			4/2 → 5/3 (A/B → EA/EB)						
				C [dm <sup>3</sup> /(s·bar)]	b	Cv	C [dm <sup>3</sup> /(s·bar)]	b	Cv				
2 position	Single	VFR2100	VFR2110	1/8	2.5	0.18	0.58	3.0	0.27	0.70	10	20 or less	0.34 (0.32)
		VFR2200	VFR2210	1/4	2.8	0.24	0.62	3.0	0.27	0.70			
	Double	VFR2100	VFR2110	1/8	2.4	0.21	0.56	3.1	0.28	0.74	10	20 or less	0.42 (0.44)
		VFR2200	VFR2210	1/4	2.6	0.27	0.62	3.1	0.28	0.74			
3 position	Closed center	VFR2300	VFR2310	1/8	1.3	0.45	0.36	1.4	0.46	0.41	5	30 or less	0.43 (0.45)
		VFR2300	VFR2310	1/4	1.3	0.45	0.36	1.4	0.46	0.41			
	Exhaust center	VFR2400	VFR2410	1/8	0.79	0.53	0.24	3.1 [0.89]	0.24 [0.51]	0.74 [0.27]	5	30 or less	0.43 (0.45)
		VFR2400	VFR2410	1/4	0.79	0.53	0.24	3.1 [0.89]	0.24 [0.51]	0.74 [0.27]			
	Pressure center	VFR2500	VFR2510	1/8	2.8 [0.65]	0.24 [0.60]	0.68 [0.21]	0.89	0.53	0.27	5	30 or less	0.43 (0.45)
		VFR2500	VFR2510	1/4	3.2 [0.75]	0.26 [0.55]	0.73 [0.23]	0.89	0.53	0.27			

Note 1) [ ]: Denotes the normal position.

Note 2) Min. operating frequency is once in 30 days.

Note 3) Based on dynamic performance test, JIS B 8419: 2010. (0.5 MPa, Coil temperature: 20°C, at rated voltage, without surge voltage suppressor)

Note 4) For VFR2□□□-□FZ-□□: ( ) : VFR2□□□-□DZ-□□



# 5 Port Pilot Operated Solenoid Valve Rubber Seal, Plug-in/Non Plug-in **VFR2000 Series**

Note) Electrical entry and light/surge voltage suppressor: D/DZ/DO/DOZ, Y/YZ/YO/YOZ, F, FZ only.



## How to Order



**Plug-in**



**Non plug-in**

**Electrical entry**

F: Plug-in type

**Option**

**Z** With light/surge voltage suppressor

**Port size (P, A, B port)**

Nil	Without sub-plate
01	1/8
02	1/4

EA, EB port: Rc 1/8

**Thread type**

NH	Rc
F	G
N	NPT
T	NPTF

**Piping (P, A, B, EA, EB port)**

Nil	Side ported
B*	Bottom ported

\* Semi-standard

**CE-compliant**

Nil	—
Q	CE-compliant (Note)

Note) Electrical entry and light/surge voltage suppressor: D/DZ/DO/DOZ, Y/YZ/YO/YOZ, F, FZ only.

**Pilot valve manual override**

Nil:	Non-locking push type
A*:	Non-locking push type A (Extended)
B*:	Locking type B (Tool required)
C*:	Locking type C (Lever)

\* Semi-standard

**Option**

Nil	None
Z	With light/surge voltage suppressor
S*	With surge voltage suppressor

\* Indicator light is not available for grommet type. With surge voltage suppressor is available for grommet type only.

**Electrical entry**

G:	Grommet
E:	Grommet terminal
T:	Conduit terminal
D, Y:	DIN terminal DO, YO, DIN terminal without connector

**Coil rated voltage**

1	100 VAC, 50/60 Hz
2	200 VAC, 50/60 Hz
3	110 to 120 VAC, 50/60 Hz
4	220 VAC, 50/60 Hz
5	24 VDC
6	12 VDC
7	240 VAC, 50/60 Hz (Note)

For other rated voltages, please consult with SMC.  
Note) L and M plug connectors: Max. 220 VAC

**Symbol**

1	2 position single (A)4 (B)2 (EA)5 1 3 (EB) (P)
2	2 position double (A)4 (B)2 (EA)5 1 3 (EB) (P)
3	3 position closed center (A)4 (B)2 (EA)5 1 3 (EB) (P)
4	3 position exhaust center (A)4 (B)2 (EA)5 1 3 (EB) (P)
5	3 position pressure center (A)4 (B)2 (EA)5 1 3 (EB) (P)

**Pilot type**

Nil	Internal pilot
R	External pilot

External pilot is available only on sub-plate type.

**CE-compliant**

Nil	—
Q	CE-compliant (Note)

**Option**

Nil	—
L:	L plug connector
M:	M plug connector

- SV
- SYJ
- SZ
- VF
- VP4
- VQ 1/2
- VQ 4/5
- VQC 1/2
- VQC 4/5
- VQZ
- SQ
- VFS
- VFR
- VQ7

## How to Order Pilot Valve Assembly

**SF4-1 DZ -60 -**

**Manual override**

Nil	Non-locking push type
A	Non-locking push type A (Extended)
B	Locking type B (Tool required)
C	Locking type C (Lever)

**CE-compliant**

Nil	—
Q	CE-compliant (Note)

Note) Electrical entry and light/surge voltage suppressor: D/DZ/DO/DOZ, Y/YZ/YO/YOZ, F only

**Coil rated voltage**

1	100 VAC, 50/60 Hz
2	200 VAC, 50/60 Hz
3	110 to 120 VAC, 50/60 Hz
4	220 VAC, 50/60 Hz
5	24 VDC
6	12 VDC
7	240 VAC, 50/60 Hz (Note)

For other rated voltages, please consult with SMC.  
Note) L and M plug connectors: Max. 220 VAC

**Electrical entry, Light/Surge voltage suppressor**

Symbol	Electrical entry	Indicator light	With surge voltage suppressor	Body type	CE-compliant
F	Plug-in	—	—	Plug-in type	●
G	Grommet	—	—	—	—
GS	Grommet	—	—	—	—
D	DIN terminal	With connector	—	Non plug-in type	●
DZ		Without connector	—		●
DO	DIN terminal (DIN43650B)	With connector	—	●	
DOZ		Without connector	—	●	
Y	DIN terminal (DIN43650B)	With connector	—	●	
YZ		Without connector	—	●	
YOZ		Without connector	—	●	

**CE-compliant**

Symbol	Electrical entry	Indicator light	With surge voltage suppressor	Body type	CE-compliant
T	Conduit terminal	—	—	—	—
TZ	Conduit terminal	●	—	—	—
E	Grommet terminal	—	—	Non plug-in type	—
EZ		—	—		—
L	L plug connector	—	—	—	—
LZ	L plug connector	●	—	—	—
LO	L plug connector (Without connector)	—	—	—	—
LOZ		—	—		—
M	M plug connector	—	—	—	—
MZ	M plug connector	●	—	—	—
MO	M plug connector (Without connector)	—	—	—	—
MOZ		—	—		—



# VFR2000 Series

Use as a guide for selection.  
Please confirm the actual conditions with SMC Sizing Program.

## Cylinder Speed Chart

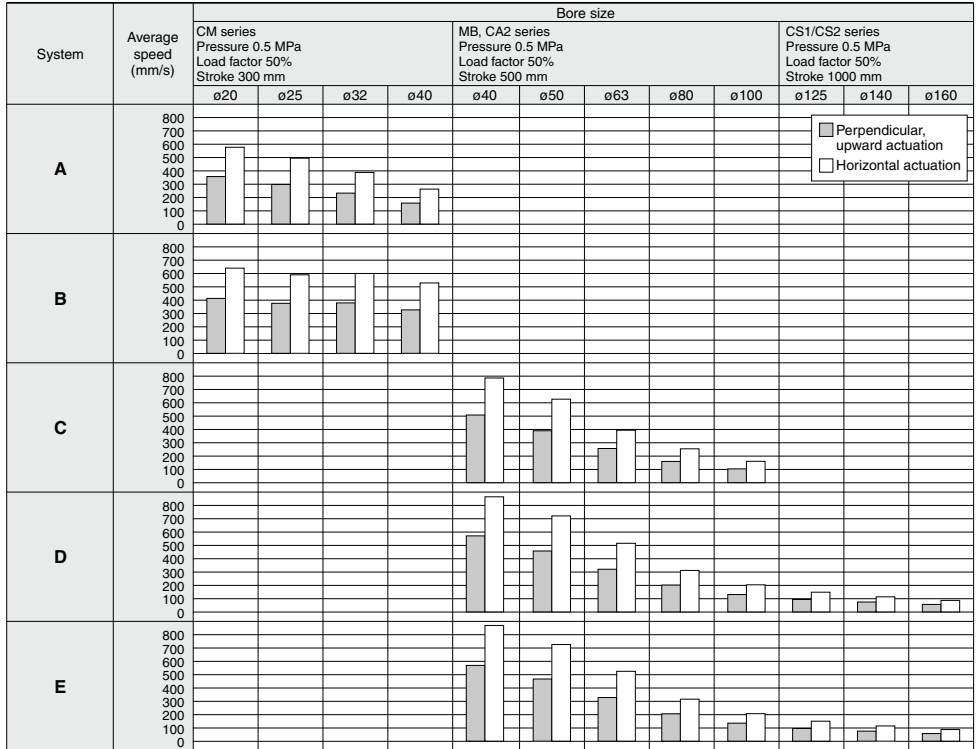

- \* It is when the cylinder is extending that is meter-out controlled by speed controller which is directly connected with cylinder, and its needle valve with being fully open.
- \* The average velocity of the cylinder is what the stroke is divided by the total stroke time.
- \* Load factor: ((Load mass x 9.8)/Theoretical force) x 100%

## System Components

System	Solenoid valve	Speed controller	Silencer	Tube bore x Length
A	VFR2000 Series Rc 1/8	AS2000-01	AN110-01	T0425 x 1 m
B		AS3000-02	AN110-01	T0604 x 1 m
C		AS3000-02	AN110-01	T0806 x 1 m
D	VFR2000 Series Rc 1/4	AS4000-02	AN110-01	T1075 x 1 m
E		AS4000-02	AN110-01	T1209 x 1 m

## How to Order Sub-plate Assembly

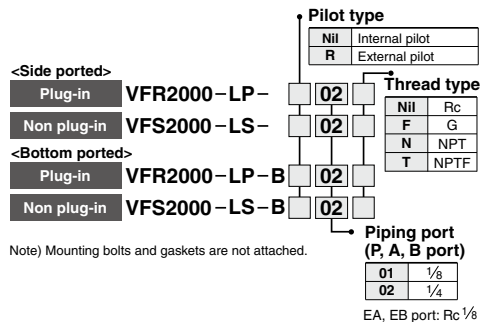

# 5 Port Pilot Operated Solenoid Valve Rubber Seal, Plug-in/Non Plug-in **VFR2000 Series**

## Construction

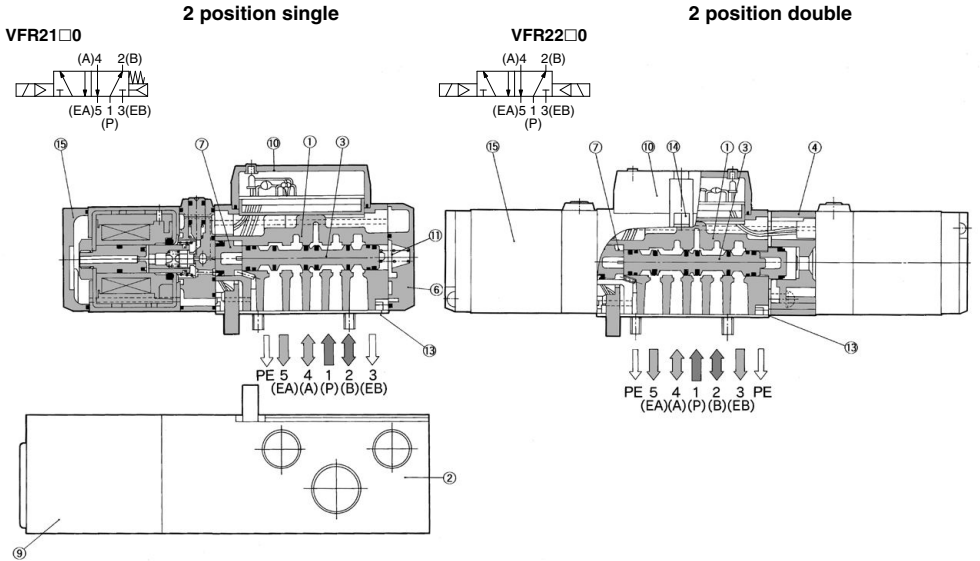

### 3 position closed center/exhaust center/pressure center

**Closed center: VFR23□0**

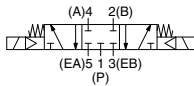

**Exhaust center: VFR24□0**



**Pressure center: VFR25□0**

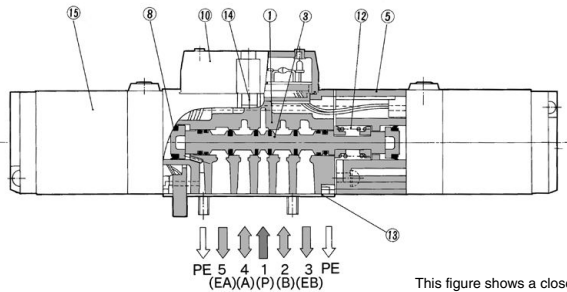
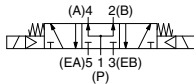

This figure shows a closed center type.

### Component Parts

No.	Description	Material	Note
1	Body	Aluminum die-casted	Platinum silver
2	Sub-plate	Aluminum die-casted	Platinum silver
3	Spool valve	Aluminum, NBR	
4	Adapter plate	Aluminum die-casted	Platinum silver
5	Adapter plate	Aluminum die-casted	Platinum silver
6	End plate	Resin	Black

### Component Parts

No.	Description	Material	Note
7	Piston	Resin	
8	Piston	Resin	
9	Junction cover	Resin	
10	Light cover assembly	Resin	
11	Spool spring	Stainless steel	
12	Return spring	Stainless steel	

### Replacement Parts

No.	Description	Material	Part no.		
			VFR21□0	VFR22□0	VFR23□0/24□0/25□0
13	Gasket	NBR	AXT624-20-2	AXT624-20-2	AXT624-20-2
14	Hexagon socket head screw <small>(Note)</small>	Steel	AXT624-26#1 (M3 x 31)	AXT624-26#1 (M3 x 31)	AXT624-26#1 (M3 x 31)
15	Pilot valve assembly	—	Refer to "How to Order Pilot Valve Assembly" on page 1019.		
—	Sub-plate assembly	—	Refer to "How to Order Sub-plate Assembly" on page 1020.		

Note) For the VFR2000 series, it requires 3 pcs.



SV
SYJ
SZ
VF
VP4
VQ 1/2
VQ 4/5
VQC 1/2
VQC 4/5
VQZ
SQ
VFS
VFR
VQ7

# VFR2000 Series

## Plug-in: 2 Position Single/Double, 3 Position Closed Center/Exhaust Center/Pressure Center

2 position single: VFR2100-□F-<sup>01</sup>/<sub>02</sub>

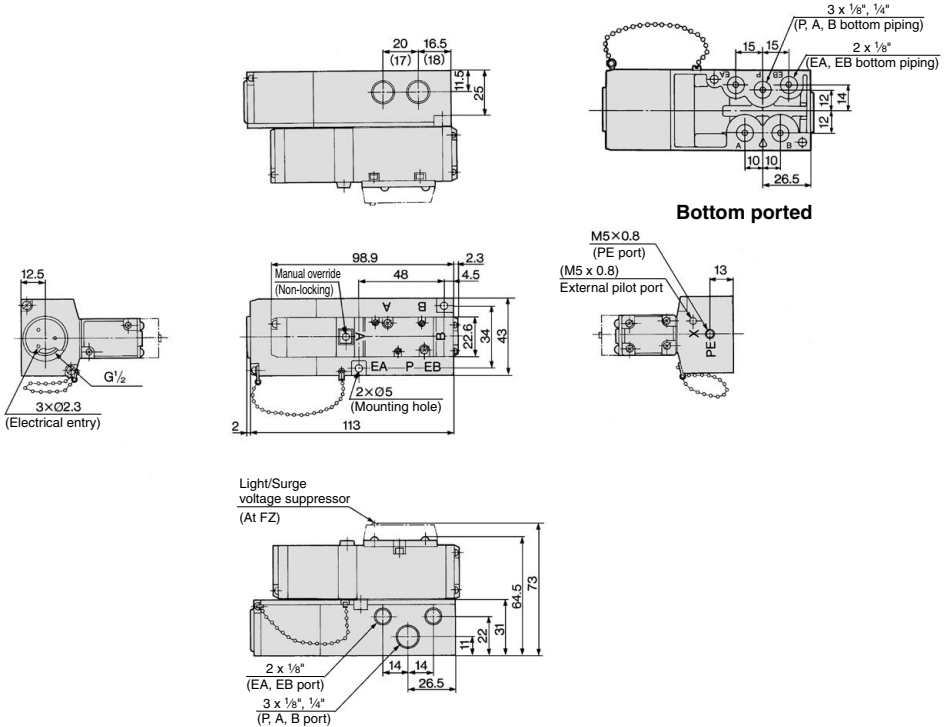

( ) : Rc 1/8

2 position double: VFR2200-□F-<sup>01</sup>/<sub>02</sub>

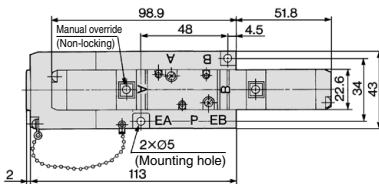

\* Other dimensions are the same as the single type.

3 position closed center: VFR2300-□F-<sup>01</sup>/<sub>02</sub>  
 3 position exhaust center: VFR2400-□F-<sup>01</sup>/<sub>02</sub>  
 3 position pressure center: VFR2500-□F-<sup>01</sup>/<sub>02</sub>

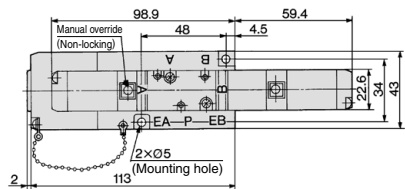

\* Other dimensions are the same as the single type.

# 5 Port Pilot Operated Solenoid Valve Rubber Seal, Plug-in/Non Plug-in **VFR2000 Series**

## Non Plug-in: 2 Position Single

Grommet: VFR2110-□G-01/02

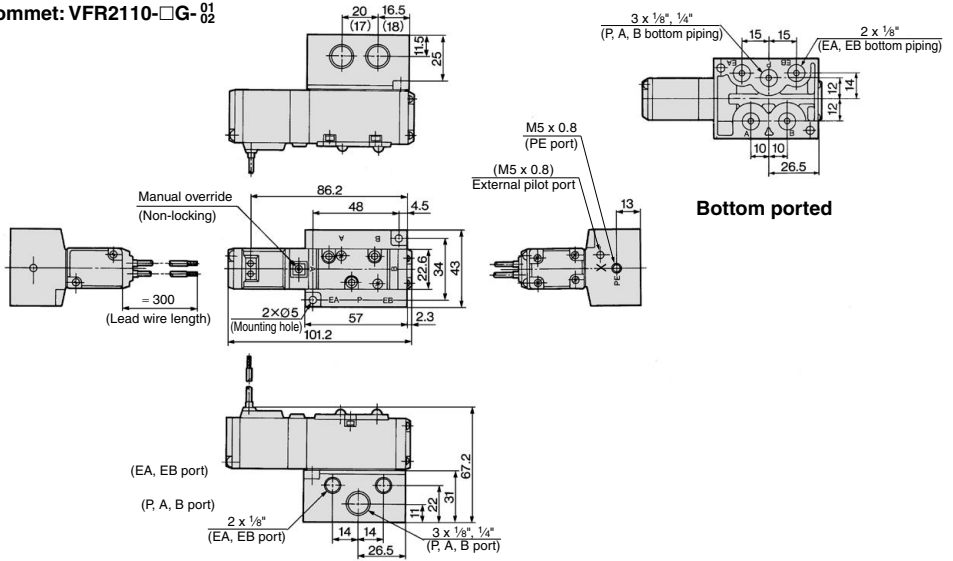

( ) : Rc 1/8

Grommet terminal: VFR2110-□E-01/02

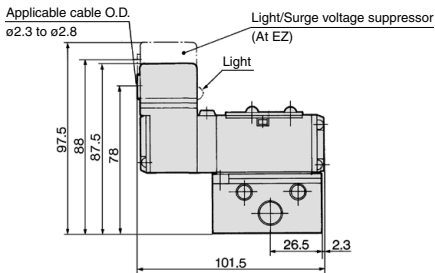

\* Other dimensions are the same as the grommet type.

Conduit terminal: VFR2110-□T-01/02

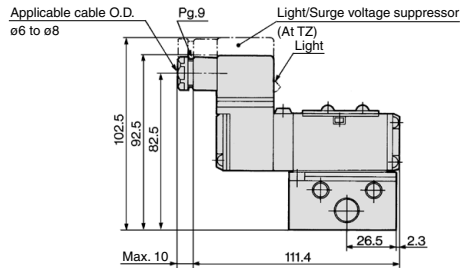

\* Other dimensions are the same as the grommet type.

DIN terminal: VFR2110-□D-01/02

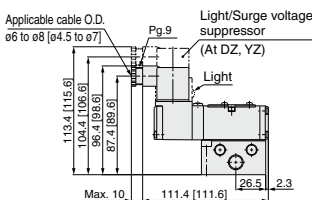

\* [ ] : Type Y  
\* Other dimensions are the same as the grommet type.

L plug connector: VFR2110-□L-01/02

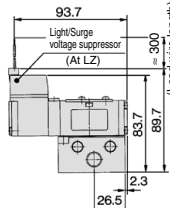

\* Other dimensions are the same as the grommet type.

M plug connector: VFR2110-□M-01/02

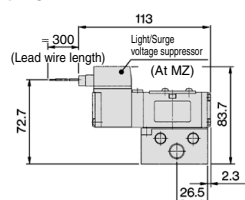

\* Other dimensions are the same as the grommet type.

SV
SYJ
SZ
VF
VP4
VQ 1/2
VQ 4/5
VQC 1/2
VQC 4/5
VQZ
SQ
VFS
VFR
VQ7

# VFR2000 Series

## Non Plug-in: 2 Position Double

Grommet: VFR2210-□G-01

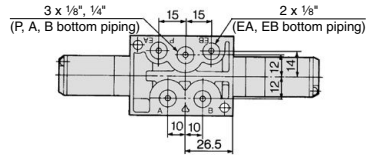
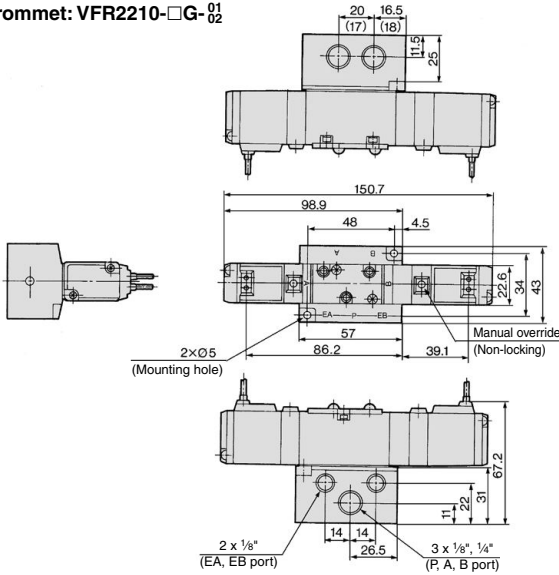

Bottom ported

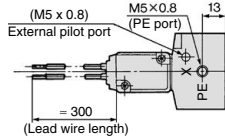

( ) : Rc 1/8

Grommet terminal: VFR2210-□E-01

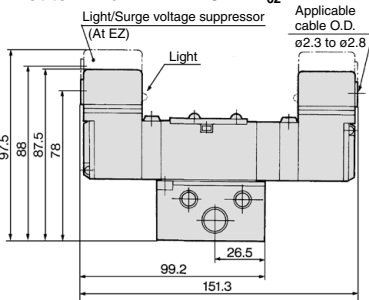

\* Other dimensions are the same as the grommet type.

Conduit terminal: VFR2210-□T-01

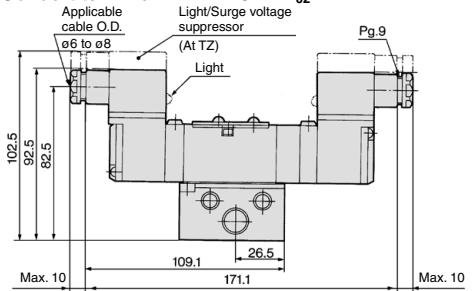

\* Other dimensions are the same as the grommet type.

DIN terminal: VFR2210-□D-01

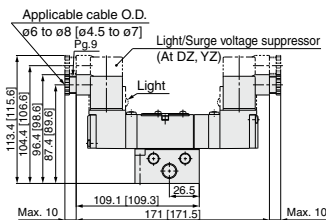

\* [ ] : Type Y  
\* Other dimensions are the same as the grommet type.

L plug connector: VFR2210-□L-01

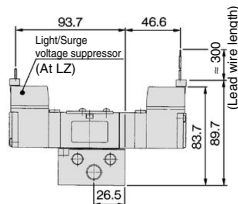

\* Other dimensions are the same as the grommet type.

M plug connector: VFR2210-□M-01

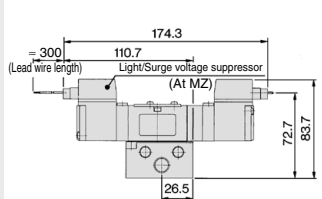

\* Other dimensions are the same as the grommet type.

# 5 Port Pilot Operated Solenoid Valve Rubber Seal, Plug-in/Non Plug-in **VFR2000 Series**

## Non Plug-in: 3 Position Closed Center/Exhaust Center/Pressure Center

### Grommet

Closed center: VFR2310-□G-<sup>01</sup>/<sub>02</sub>  
 Exhaust center: VFR2410-□G-<sup>01</sup>/<sub>02</sub>  
 Pressure center: VFR2510-□G-<sup>01</sup>/<sub>02</sub>

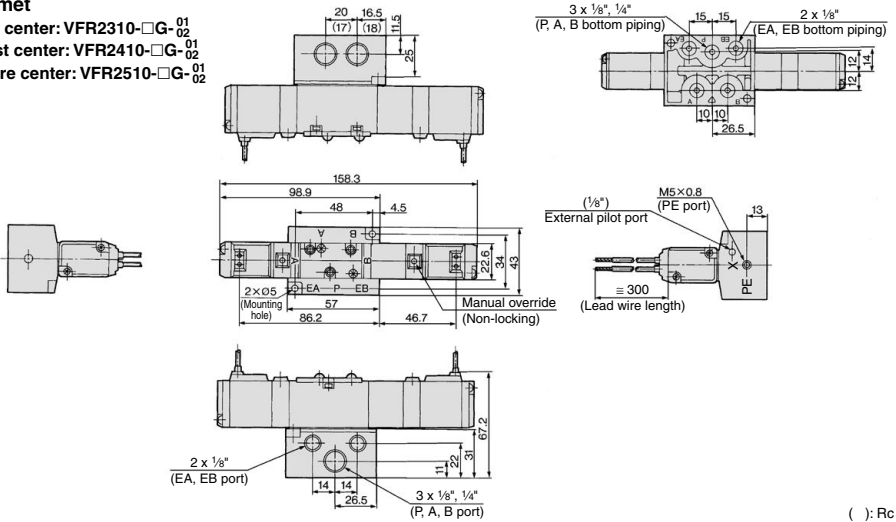

### Grommet terminal

Closed center: VFR2310-□E-<sup>01</sup>/<sub>02</sub>  
 Exhaust center: VFR2410-□E-<sup>01</sup>/<sub>02</sub>  
 Pressure center: VFR2510-□E-<sup>01</sup>/<sub>02</sub>

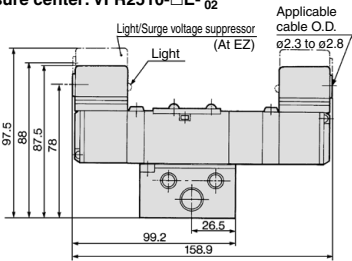

\* Other dimensions are the same as the grommet type.

### Conduit terminal

Closed center: VFR2310-□T-<sup>01</sup>/<sub>02</sub>  
 Exhaust center: VFR2410-□T-<sup>01</sup>/<sub>02</sub>  
 Pressure center: VFR2510-□T-<sup>01</sup>/<sub>02</sub>

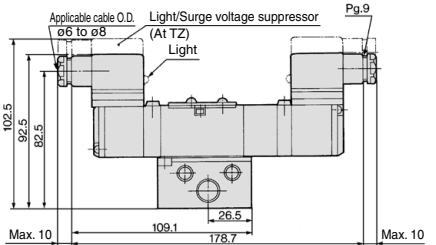

\* Other dimensions are the same as the grommet type.

### DIN terminal

Closed center: VFR2310-□D-<sup>01</sup>/<sub>02</sub>  
 Exhaust center: VFR2410-□D-<sup>01</sup>/<sub>02</sub>  
 Pressure center: VFR2510-□D-<sup>01</sup>/<sub>02</sub>

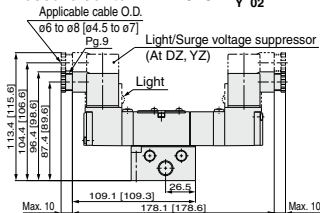

\* [ ] : Type Y  
 \* Other dimensions are the same as the grommet type.

### L plug connector

Closed center: VFR2310-□L-<sup>01</sup>/<sub>02</sub>  
 Exhaust center: VFR2410-□L-<sup>01</sup>/<sub>02</sub>  
 Pressure center: VFR2510-□L-<sup>01</sup>/<sub>02</sub>

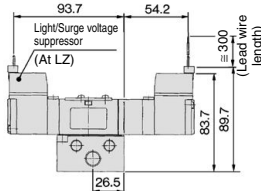

\* Other dimensions are the same as the grommet type.

### M plug connector

Closed center: VFR2310-□M-<sup>01</sup>/<sub>02</sub>  
 Exhaust center: VFR2410-□M-<sup>01</sup>/<sub>02</sub>  
 Pressure center: VFR2510-□M-<sup>01</sup>/<sub>02</sub>

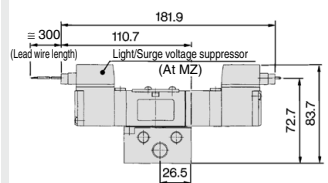

\* Other dimensions are the same as the grommet type.

SV
SYJ
SZ
VF
VP4
VQ 1/2
VQ 4/5
VQC 1/2
VQC 4/5
VQZ
SQ
VFS
VFR
VQ7

( ) : Rc 1/8





# VFR2000 Series Manifold Specifications

## Manifold Specifications

Base model	Wiring	Porting specifications		Port size		Stations	Applicable valve model
		A, B port		P, EA, EB	A, B		
Plug-in type VV5FR2-01□(-Q)	<ul style="list-style-type: none"> <li>• With terminal block</li> <li>• With multi-connector</li> <li>• With D-sub connector</li> </ul>	Side/Bottom	1/4	1/8, 1/4 C6, C8	2 to 15	VFR2□00-□F(-Q)	
							2 to 8
Non plug-in type VV5FR2-10(-Q)	<ul style="list-style-type: none"> <li>• Grommet</li> <li>• Grommet terminal</li> <li>• Conduit terminal</li> <li>• DIN terminal</li> <li>• L plug connector</li> <li>• M plug connector</li> </ul>				2 to 15	VFR2 10-□G VFR2□10-□E VFR2□10-□T VFR2□10-□D(-Q) VFR2□10-□L VFR2□10-□M	

Note) Side ported and bottom ported cannot be taken at the same time.

## How to Order Manifold Assembly

<Example> Plug-in type with terminal block (6 stations, one-piece junction cover)

VV5FR2-01T1-061-02 (-Q) ..... 1 set (Manifold base part no.)  
 \*VFR2100-5FZ (-Q) ..... 3 sets (2 position single part no.)  
 \*VFR2200-5FZ (-Q) ..... 2 sets (2 position double part no.)  
 \*VVFS2000-10A ..... 1 set (Blanking plate assembly part no.)

The asterisk denotes the symbol for assembly. Prefix it to the part nos. of the solenoid valve, etc.

Valve arrangement is counted from the D side.

When ordering, specify the part nos. in order from the 1st. station in the D side.

When entry of part numbers becomes complicated, indicate on the manifold specification sheet.

<Example> Non plug-in type: 6 stations

VV5FR2-10-061-01 (-Q) ..... 1 set (Manifold base part no.)  
 \*VFR2110-5D (-Q) ..... 5 sets (2 position single part no.)  
 \*VFR2410-5D (-Q) ..... 1 set (3 position exhaust part no.)  
 \*VVFS2000-R-01-2 ..... 1 set (Individual EXH spacer part no.)

The asterisk denotes the symbol for assembly. Prefix it to the part nos. of the solenoid valve, etc.

Valve arrangement is counted from the D side.

When ordering, specify the part nos. in order from the 1st. station in the D side.

When entry of part numbers becomes complicated, indicate on the manifold specification sheet.



### Plug-in Type: With Terminal Block

- Since lead wires of solenoid valve are connected with the terminals on upper surface of terminal block corresponding lead wires from power source can be wired at the bottom of terminal block.

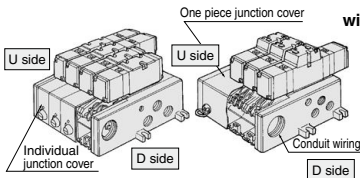

Note) P port or EA/EB port of symbol "3" to "8" can be individual port with block plate. Therefore, if using individual SUP spacer or individual EXH spacer for individual port, its symbol is "1".

**VV5FR2-01T 1-08 1-02**

VFR2000 Series Manifold

Plug-in type with terminal block

Junction cover

Nil	Individual junction cover
1	One-piece junction cover

Stations

02	2 stations
⋮	⋮
15	15 stations

Symbol<sup>+2, +3</sup>

Symbol	Passage*1	Porting specification A, B
1	Common	Common
2*	Common	Side
3*	Common	Bottom
4*	Common	Individual
5*	Individual	Common
6*	Individual	Side
7*	Individual	Bottom
8*	Individual	Individual

\* Semi-standard

+ 1 When an individual passage is used, P, EA and EB ports will be bottom ported.

+ 2 For bottom ported, A/B port size is 1/8 (Symbol 01) only.

+ 3 Symbol "1" is only applicable to One-touch fittings (C6, C8).

Port size<sup>+2, +3</sup>

Symbol	P, EA, EB	A, B
01	1/8	1/8
02	1/4	1/4
C6	1/4	One-touch fitting for ø6
C8	1/4	One-touch fitting for ø8
M		Mixed

CE-compliant

Nil	—
Q	CE-compliant

Thread type

Symbol	Rc
F	G
N	NPT
T	NPTF

### Plug-in Type: With Multi-connector (For wiring specifications, refer to page 1113.)

- Master connection of power and solenoid valves.
- Quick wiring permits ease of installation.

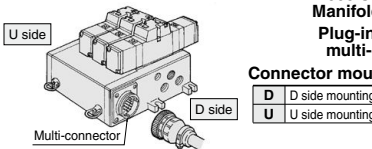

Note) P port or EA/EB port of symbol "3" to "8" can be individual port with block plate. Therefore, if using individual SUP spacer or individual EXH spacer for individual port, its symbol is "1".

**VV5FR2-01C D 1-05 1-01**

VFR2000 Series Manifold

Plug-in type with multi-connector

Connector mounting direction

D	D side mounting
U	U side mounting

Junction cover

1	One-piece junction cover
---	--------------------------

Stations

02	2 stations
⋮	⋮
08	8 stations

\* Max. 8 stations

Symbol<sup>+2, +3</sup>

Symbol	Passage*1	Porting specification A, B
1	Common	Common
2*	Common	Side
3*	Common	Bottom
4*	Common	Individual
5*	Individual	Common
6*	Individual	Side
7*	Individual	Bottom
8*	Individual	Individual

\* Semi-standard

+ 1 When an individual passage is used, P, EA and EB ports will be bottom ported.

+ 2 For bottom ported, A/B port size is 1/8 (Symbol 01) only.

+ 3 Symbol "1" is only applicable to One-touch fittings (C6, C8).

Port size<sup>+2, +3</sup>

Symbol	P, EA, EB	A, B
01	1/8	1/8
02	1/4	1/4
C6	1/4	One-touch fitting for ø6
C8	1/4	One-touch fitting for ø8
M		Mixed

CE-compliant

Nil	—
Q	CE-compliant

Thread type

Symbol	Rc
F	G
N	NPT
T	NPTF

# 5 Port Pilot Operated Solenoid Valve Rubber Seal, Plug-in/Non Plug-in **VFR2000 Series**

Note) Electrical entry and light/surge voltage suppressor: D/DZ/DO/DOZ, YYZ/YO/YOZ, F, FZ only.



## Plug-in Type: With D-sub Connector (For wiring specifications, refer to page 1113.)

- Wide range of interchangeability (D-sub connector (25P) conforming to ML standard)
- Quick wiring permits easier installation.

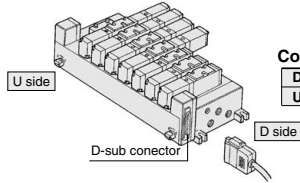

**VV5FR2 - 01F U 1 - 06 1 - 01**

VFR2000 Series Manifold

Plug-in type with D-sub connector

Connector mounting direction  
**D** D side mounting  
**U** U side mounting

Junction cover  
**1** One-piece junction cover

Stations	
<b>02</b>	2 stations
⋮	⋮
<b>08</b>	8 stations

\* Max. 8 stations

Symbol <sup>+2, +3</sup>

Symbol	Passage <sup>*1</sup>		Porting specification
	P	EA, EB	
<b>1</b>	Common	Common	Side
<b>2</b> <sup>*</sup>	Common	Common	Bottom
<b>3</b> <sup>*</sup>	Common	Individual	Side
<b>4</b> <sup>*</sup>	Common	Individual	Bottom
<b>5</b> <sup>*</sup>	Individual	Common	Side
<b>6</b> <sup>*</sup>	Individual	Common	Bottom
<b>7</b> <sup>*</sup>	Individual	Individual	Side
<b>8</b> <sup>*</sup>	Individual	Individual	Bottom

\* Semi-standard

\* 1 When an individual passage is used, P, EA and EB ports will be bottom ported.

\* 2 For bottom ported, A/B port size is 1/8 (Symbol 01) only.

\* 3 Symbol "1" is only applicable to One-touch fittings (C6, C8).

Thread type

Nil	Rc
<b>F</b>	G
<b>N</b>	NPT
<b>T</b>	NPTF

CE-compliant

Nil	—
<b>Q</b>	CE-compliant

Note) Electrical entry and light/surge voltage suppressor: F, FZ only.

Port size <sup>+2, +3</sup>

Symbol	P, EA, EB	A, B
<b>01</b>	1/8	1/8
<b>02</b>	1/4	1/4
<b>C6</b>	1/4	One-touch fitting for ø6
<b>C8</b>	1/4	One-touch fitting for ø8
<b>M</b>		Mixed

Note) P port or EA/EB port of symbol "3" to "8" can be individual port with block plate. Therefore, if using individual SUP spacer or individual EXH interface for individual port, its symbol is "1".

## Non Plug-in Type: Grommet, Grommet Terminal, Conduit Terminal, DIN Terminal

- Wiring for every valve

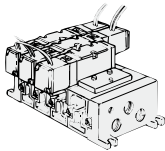

**VV5FR2 - 10 - 05 1 - 01**

VFR2000 Series Manifold

Non plug-in type

Stations	
<b>02</b>	2 stations
⋮	⋮
<b>15</b>	15 stations

Symbol <sup>+2, +3</sup>

Symbol	Passage <sup>*1</sup>		Porting specification
	P	EA, EB	
<b>1</b>	Common	Common	Side
<b>2</b> <sup>*</sup>	Common	Common	Bottom
<b>3</b> <sup>*</sup>	Common	Individual	Side
<b>4</b> <sup>*</sup>	Common	Individual	Bottom
<b>5</b> <sup>*</sup>	Individual	Common	Side
<b>6</b> <sup>*</sup>	Individual	Common	Bottom
<b>7</b> <sup>*</sup>	Individual	Individual	Side
<b>8</b> <sup>*</sup>	Individual	Individual	Bottom

\* Semi-standard

\* 1 When an individual passage is used, P, EA and EB ports will be bottom ported.

\* 2 For bottom ported, A/B port size is 1/8 (Symbol 01) only.

\* 3 Symbol "1" is only applicable to One-touch fittings (C6, C8).

Thread type

Nil	Rc
<b>F</b>	G
<b>N</b>	NPT
<b>T</b>	NPTF

CE-compliant

Nil	—
<b>Q</b>	CE-compliant

Note) Electrical entry and light/surge voltage suppressor: D/DZ/DO/DOZ, YYZ/YO/YOZ only.

Port size <sup>+2, +3</sup>

Symbol	P, EA, EB	A, B
<b>01</b>	1/8	1/8
<b>02</b>	1/4	1/4
<b>C6</b>	1/4	One-touch fitting for ø6
<b>C8</b>	1/4	One-touch fitting for ø8
<b>M</b>		Mixed

Note) P port or EA/EB port of symbol "3" to "8" can be individual port with block plate. Therefore, if using individual SUP spacer or individual EXH spacer for individual port, its symbol is "1".

- SV
- SYJ
- SZ
- VF
- VP4
- VQ 1/2
- VQ 4/5
- VQC 1/2
- VQC 4/5
- VQZ
- SQ
- VFS
- VFR
- VQ7

# VFR2000 Series

## Manifold/Option Parts Assembly

### Individual SUP spacer

Setting individual SUP spacer on the manifold block enables individual SUP port for each valve.

Body type	Plug-in type	Non plug-in type
Rc 1/8	VVFS2000-P-01-1	VVFS2000-P-01-2
Rc 1/4	VVFS2000-P-02-1	VVFS2000-P-02-2

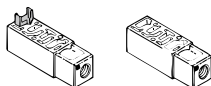

### Individual EXH spacer

Setting individual EXH spacer on the manifold block enables individual EXH port for each valve.

Body type	Plug-in type	Non plug-in type
Rc 1/8	VVFS2000-R-01-1	VVFS2000-R-01-2
Rc 1/4	VVFS2000-R-02-1	VVFS2000-R-02-2

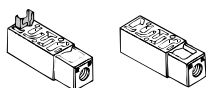

### SUP block disk <sup>Note)</sup>

When supplying manifold with more than two different kinds of pressure, high and low, insert a block disk in between stations subjected to different pressures.

Body type	Plug-in type	Non plug-in type
	AXT625-12A	

### EXH block disk <sup>Note)</sup>

When valve exhaust affects the other stations in the circuit, insert EXH block disk in between stations to separate valve exhaust.

Body type	Plug-in type	Non plug-in type
	AXT625-12A	



Note) Cannot be used for the 2 stations integrated manifold block

### Throttle valve spacer

Needle valve set on the manifold block can control cylinder speed by throttling exhaust.

Body type	Plug-in type	Non plug-in type
Part no.	VVFS2000-20A-1	VVFS2000-20A-2

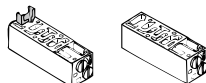

### Interface regulator

Interface regulator set on the manifold block can regulate pressure for each valve. (Refer to "Flow Rate Characteristics" on page 1111 before operation.)

Body type	Plug-in type	Non plug-in type
P port regulation	ARBF2000-00-P-1	ARBF2000-00-P-2

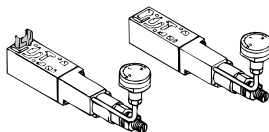

### Air release valve spacer

Valve VFR21□0 (single) can be used as air release valve by combining with release valve spacer.

Body type	Plug-in type	Non plug-in type
Part no.	VVFS2000-24A-1	VVFS2000-24A-2

Note) L: U side mount R: D side mount

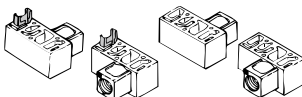

### SUP stop valve spacer <sup>Note)</sup>

If SUP stop valve spacer is set, valve can be removed for maintenance without stopping air pressure supply for other valves.

Body type	Plug-in type	Non plug-in type
Part no.	VVFS2000-37A-1	VVFS2000-37A-2

(Height will be 23.2 mm higher.)

Note) Used with manifold base.  
Please contact SMC for details.

### Blanking plate

It is used by attaching on the manifold block for being prepared for removing a valve for maintenance reasons or planning to mount a spare valve, etc.

Body type	Plug-in type	Non plug-in type
Part no.	VVFS2000-10A	

## Manifold Option

### With control unit

#### Plug-in/Non plug-in type

- Filter, regulation valve, pressure switch and air release valve all combine to form one unit.
- Piping processes are eliminated.

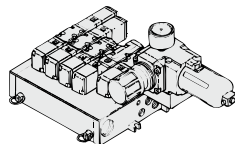

For details, refer to page 1033.

# 5 Port Pilot Operated Solenoid Valve Rubber Seal, Plug-in/Non Plug-in **VFR2000 Series**

## Manifold/Plug-in Type

With terminal block (Individual junction cover): **VV5FR2-01T-Station 1-Port size**

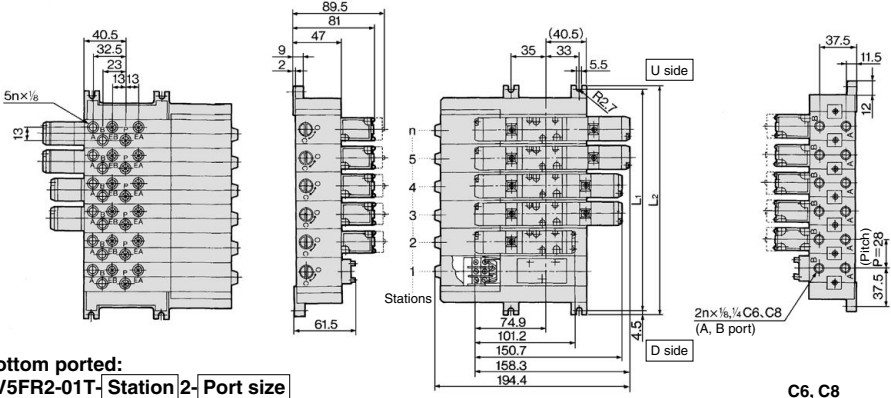

Bottom ported:  
**VV5FR2-01T-Station 2-Port size**

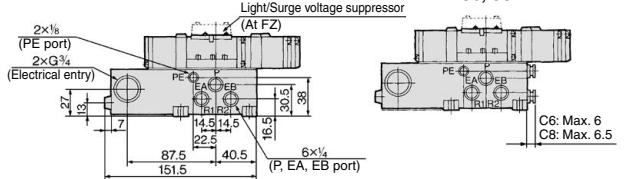

With terminal block (One-piece junction cover): **VV5FR2-01T1-Station 1-Port size**

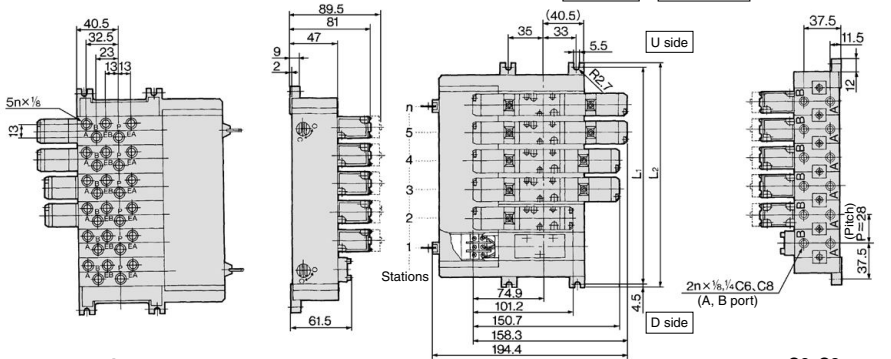

Bottom ported:  
**VV5FR2-01T1-Station 2-Port size**

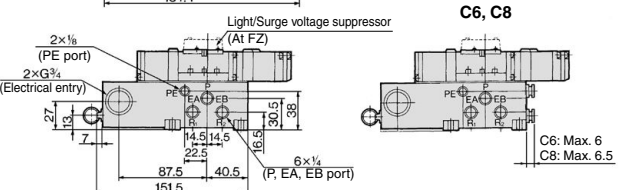

n: Stations	1	2	3	4	5	6	7	8	9	10	Formula
L <sub>1</sub>	75	103	131	159	187	215	243	271	299	327	L <sub>1</sub> = 28 x n + 47
L <sub>2</sub>	84	112	140	168	196	224	252	280	308	336	L <sub>2</sub> = 28 x n + 56

- SV
- SYJ
- SZ
- VF
- VP4
- VQ 1/2
- VQ 4/5
- VQC 1/2
- VQC 4/5
- VQZ
- SQ
- VFS
- VFR
- VQ7



# VFR2000 Series

## Manifold/Plug-in Type

With multi-connector: **VV5FR2-01CD1-Station 1-Port size**, **VV5FR2-01CU1-Station 1-Port size**

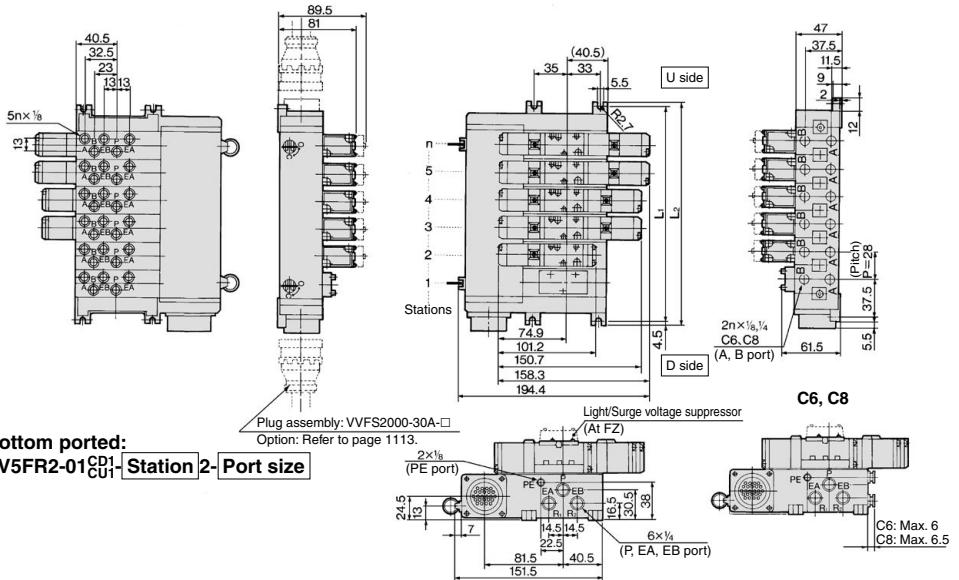

Bottom ported:  
**VV5FR2-01CD1-Station 2-Port size**, **VV5FR2-01CU1-Station 2-Port size**

For wiring specifications, refer to page 1113.

With D-sub connector: **VV5FR2-01FD1-Station 1-Port size**, **VV5FR2-01FU1-Station 1-Port size**

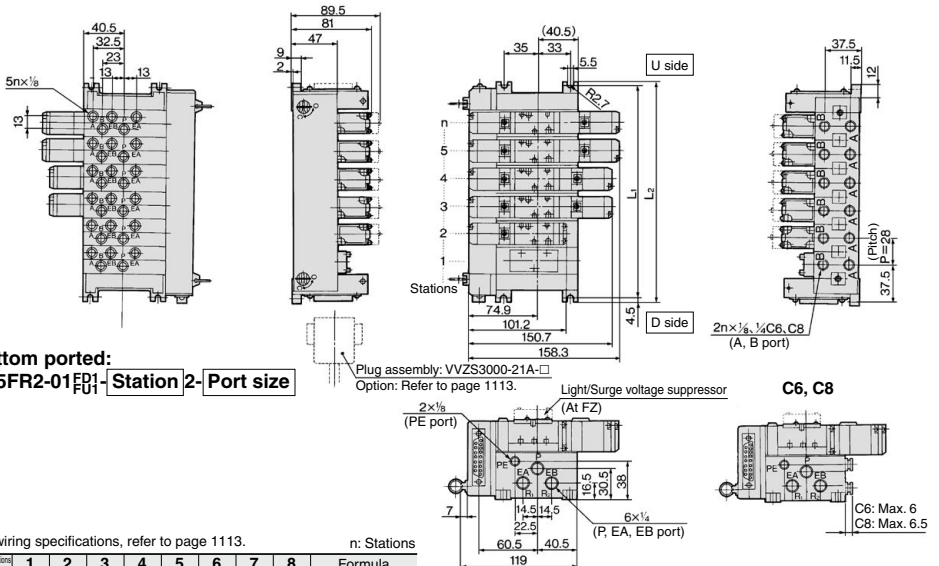

For wiring specifications, refer to page 1113.

Station	1	2	3	4	5	6	7	8	Formula
L <sub>1</sub>	75	103	131	159	187	215	243	271	L <sub>1</sub> = 28 x n + 47
L <sub>2</sub>	84	112	140	168	196	224	252	280	L <sub>2</sub> = 28 x n + 56

n: Stations

5 Port Pilot Operated Solenoid Valve  
Rubber Seal, Plug-in/Non Plug-in **VFR2000 Series**

**Manifold/Non plug-in type: VV5FR2-10-Station 1-Port size**

**Grommet: G**

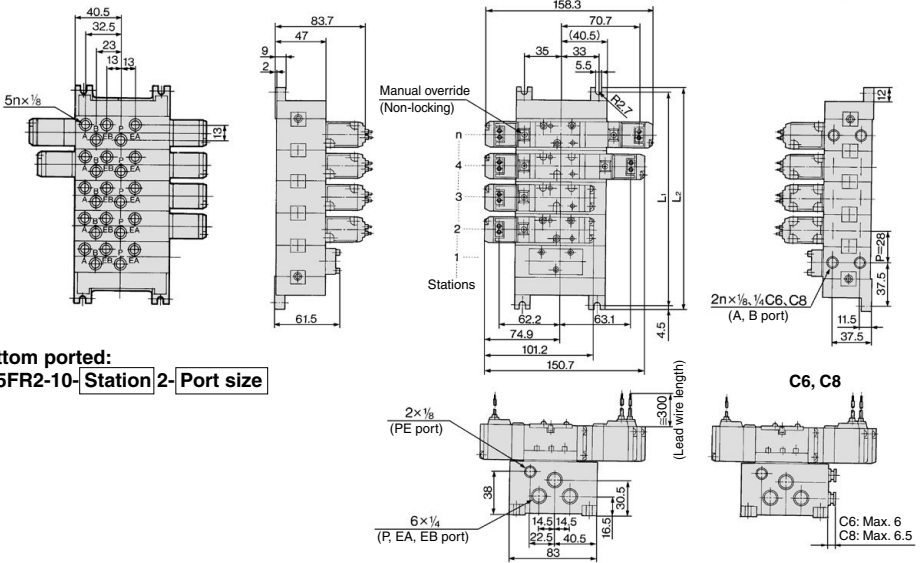

**Bottom ported:  
VV5FR2-10-Station 2-Port size**

**Grommet terminal: E**

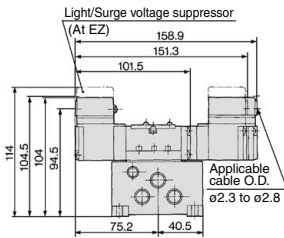

**Conduit terminal: T**

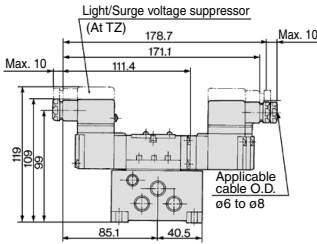

**DIN terminal: D, Y**

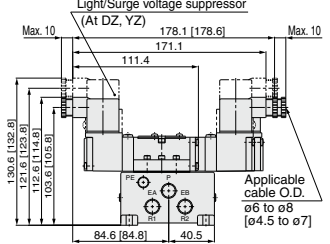

= [ ] : Type Y

**L plug connector: L**

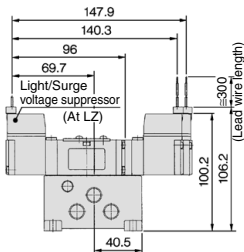

**M plug connector: M**

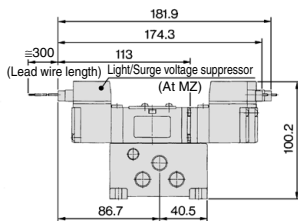

n: Stations

Station	1	2	3	4	5	6	7	8	9	10	Formula
L <sub>1</sub>	75	103	131	159	187	215	243	271	299	327	L <sub>1</sub> = 28 x n + 47
L <sub>2</sub>	84	112	140	168	196	224	252	280	308	336	L <sub>2</sub> = 28 x n + 56

- SV
- SYJ
- SZ
- VF
- VP4
- VQ 1/2
- VQ 4/5
- VQC 1/2
- VQC 4/5
- VQZ
- SQ
- VFS
- VFR
- VQ7

# VFR2000 Series

## Manifold/Option Parts Assembly: Plug-in Type/Non Plug-in Type

Individual SUP spacer:

VVFS2000-P-01-1 (Plug-in type)

VVFS2000-P-01-2 (Non plug-in type)

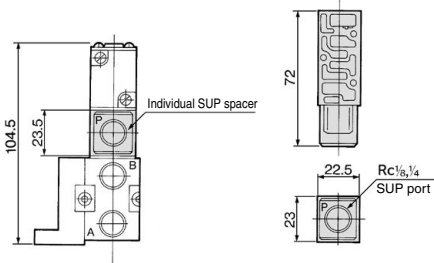

Throttle valve spacer:

VVFS2000-20A-1 (Plug-in type)

VVFS2000-20A-2 (Non plug-in type)

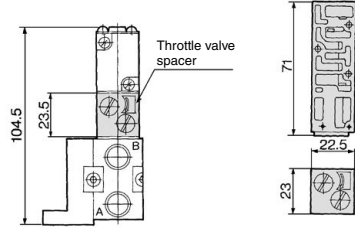

Individual EXH spacer:

VVFS2000-R-01-1 (Plug-in type)

VVFS2000-R-01-2 (Non plug-in type)

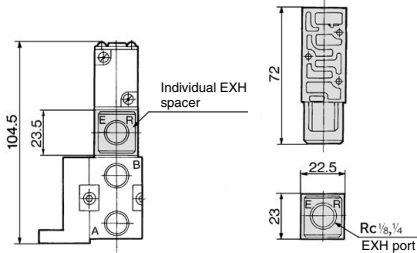

Interface regulator

ARBF2000-00-P-1 (Plug-in type)

ARBF2000-00-P-2 (Non plug-in type)

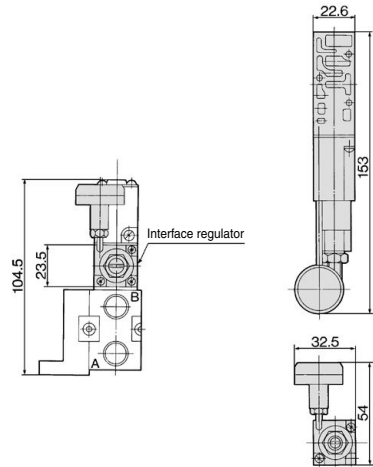

SUP block disk: AXT625-12A

EXH block disk: AXT625-12A

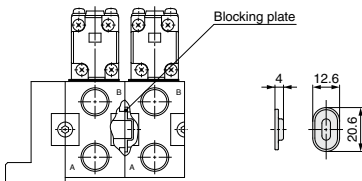

Note) Cannot be used for the 2 stations integrated manifold block

Release valve spacer

VVFS2000-24A-1<sup>R</sup> (Plug-in type)

VVFS2000-24A-2<sup>L</sup> (Non plug-in type)

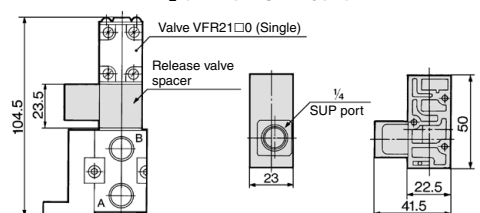

Note) VVFS2000-24A-1/2R (D side mounting)



## Manifold with Control Unit

- Control unit (Filter, Regulator, Pressure switch, Air release valve) are all standardized to the one unit, and can be mounted on the manifold base without any attachments.
- Piping processes are eliminated.

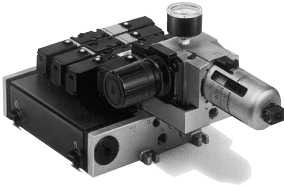

Plug-in type

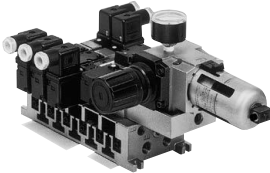

Non plug-in type

### ⚠ Caution

Air filter with auto-drain or manual drain must be mounted with the air filter at the bottom.

### Manifold Specifications

Manifold	Plug-in type: <b>VV5FR2-01□(-Q)</b>	Non plug-in type: <b>VV5FR2-10(-Q)</b>
<b>Wiring</b>	With terminal block With multi-connector With D-sub connector	Grommet, Grommet terminal Conduit terminal, DIN terminal L plug connector, M plug connector
<b>Applicable valve model</b>	VFR2□00-□F(-Q)	VFR2□10-□G, VFR2□10-□E VFR2□10-□T, VFR2□10-□DY(-Q) VFR2□10-□L, VFR2□10-□M
<b>Porting specifications</b>	Common SUP, Common EXH	
	A, B port	Side: Rc 1/8, 1/4, C6, C8, Bottom: Rc 1/8 (Option)
<b>Rc</b>	P, EA, EB port	Side: Rc 1/4, Bottom: Rc 1/8 (Option)
<b>Stations</b>	2 to 15 stations * (With multi-connector/D-sub connector: 2 to 8 stations)	

\* Including station of control unit

### Control Unit Specifications

Air filter (With auto-drain/With manual drain)	
<b>Filtration degree</b>	5 μm
Regulator	
<b>Set pressure (Outlet pressure)</b>	0.05 to 0.85 MPa
Pressure switch	
<b>Set pressure range: OFF</b>	0.1 to 0.6 MPa
<b>Differential</b>	0.08 MPa
<b>Contact</b>	1a
<b>Indicator light</b>	LED (RED)
<b>Max. switch capacity</b>	2 VA AC, 2 W DC
<b>Max. operating current</b>	24 VDC or less: 50 mA 100 VAC: 20 mA
<b>Inside voltage drop</b>	4 V or less
Air release valve (Single only)	
<b>Operating pressure range</b>	0.2 to 0.9 MPa

### Control Unit/Option

Air release valve spacer	<Plug-in type> VVFS2000-24A-1R (D side mounting) VVFS2000-24A-1L (U side mounting)	
	<Non plug-in type> VVFS2000-24A-2R (D side mounting) VVFS2000-24A-2L (U side mounting)	
Pressure switch	IS1000P-2-1	
Blanking plate	For filter regulator	MP2-2
	For pressure switch	MP3-2
	For air release valve	AXT625-18A
Filter element	111511-5B	

Note 1) Refer to "Manifold Option" on page 1032.  
Note 2) Pressure switch cannot be mounted later on non plug-in type.

SV

SYJ

SZ

VF

VP4

VQ  
1/2

VQ  
4/5

VQC  
1/2

VQC  
4/5

VQZ

SQ

VFS

VFR

VQ7

## How to Order

**VV5FR2** - **10** - **08** **1** - **01** - **AP** -

VFR2000 Series Manifold

### Base model

Symbol	Electrical entry	Connector mounting direction	Junction cover
01T	Plug-in type terminal block	—	Stacking type
01T1			Integrated type
01CD1	Plug-in type multi-connector	D side	Integrated type
01CU1		U side	
01FD1	Plug-in type D-sub connector	D side	Integrated type
01FU1		U side	
10	Non plug-in type	—	—

### Stations

02	2 stations
⋮	⋮
15 <small>Note)</small>	15 stations

- Note) • 01CD1, 01CU1, 01FD1, 01FU1: Max. 8 stations  
 • 01T, 01T1, 10: Max. 15 stations  
 • Including station of control unit

### Symbol <sup>+2, +3</sup>

Symbol	Passage <sup>*1</sup>		Porting specifications (A, B)
	P	EA, EB	
1	Common	Common	Side
2*			Bottom
3*	Common	Individual	Side
4*			Bottom
5*	Individual	Common	Side
6*			Bottom
7*	Individual	Individual	Side
8*			Bottom

\* Semi-standard

\* 1 When an individual passage is used, P, EA and EB ports will be bottom ported.

\* 2 For bottom ported, A/B port size is 1/8 (Symbol 01) only.

\* 3 Symbol "1" is only applicable to One-touch fittings (C6, C8).

Note) P port or EA/EB port of symbol "3" to "8" can be individual port with block disk.

Therefore, if using individual SUP spacer or individual EXH spacer for individual port, its symbol is "1".

## How to Order Manifold Assembly

<Example> Plug-in type with terminal block

VV5FR2-01T1-091-02-MP5 (-Q) ..... 1 set (Manifold base part no.)  
 \*VFR2100-5FZ (-Q) ..... 5 sets (2 position single part no.)  
 \*VFR2200-5FZ (-Q) ..... 2 sets (2 position double part no.)

↳ The asterisk denotes the symbol for assembly. Prefix it to the part nos. of the solenoid valve, etc.

<Example> Non plug-in type

VV5FR2-10-071-01-M5 (-Q) ..... 1 set (Manifold base part no.)  
 \*VFR2110-5D (-Q) ..... 5 sets (2 position single part no.)

↳ The asterisk denotes the symbol for assembly. Prefix it to the part nos. of the solenoid valve, etc.

The 1st and 2nd station are used for control unit mounting. When ordering, specify the part nos. in order from the 3rd. station in the D side. When entry of part numbers becomes complicated, indicate on the manifold specification sheet.

The 1st and 2nd station are used for control unit mounting. When ordering, specify the part nos. in order from the 3rd. station in the D side. When entry of part numbers becomes complicated, indicate on the manifold specification sheet.

# 5 Port Pilot Operated Solenoid Valve Rubber Seal, Plug-in/Non Plug-in **VFR2000 Series**

## Manifold with Control Unit: Plug-in Type/Non Plug-in Type

**Plug-in type:**

**VV5FR2-01T-Station 1-Port size-Control unit-Voltage of air release valve**

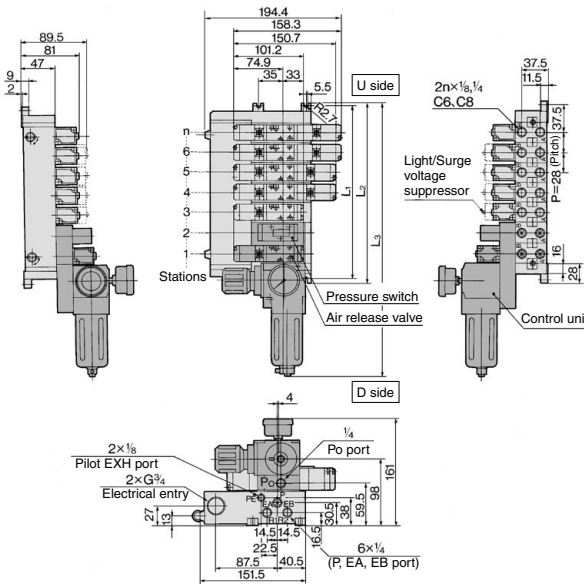

**Example for manifold**

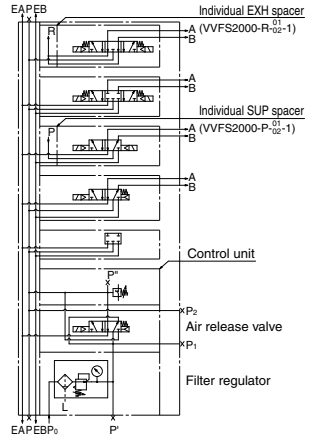

**Non plug-in type:**

**VV5FR2-10-Station 1-Port size-Control unit-Voltage of air release valve**

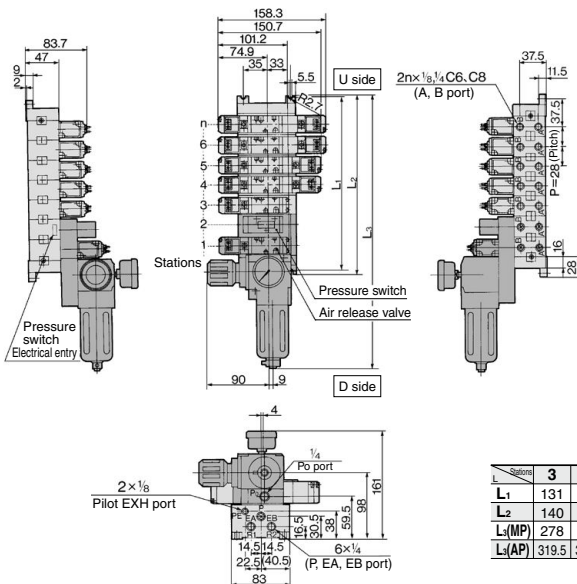

**Example for manifold**

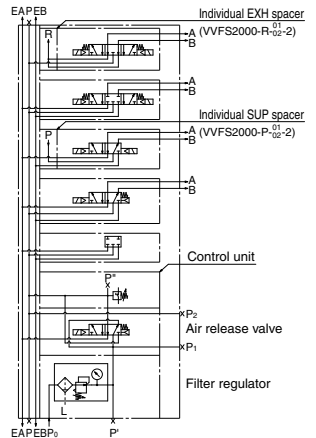

		n: Stations									
		Formula									
$L_1$	3 4 5 6 7 8 9 10	131	159	187	215	243	271	299	327	$L_1 = 28 \times n + 47$	
$L_2$		140	168	196	224	252	280	308	336	$L_2 = 28 \times n + 56$	
$L_3(MP)$		278	306	334	362	390	418	446	474	$L_3 = 28 \times n + 194$	
$L_4(AP)$		319.5	347.5	375.5	403.5	431.5	459.5	487.5	515.5	$L_4 = 28 \times n + 235.5$	



- SV
- SYJ
- SZ
- VF
- VP4
- VQ 1/2
- VQ 4/5
- VQC 1/2
- VQC 4/5
- VQZ
- SQ
- VFS
- VFR
- VQ7

# VFR2000 Series

## Manifold Base Construction — Plug-in Type, Non Plug-in Type

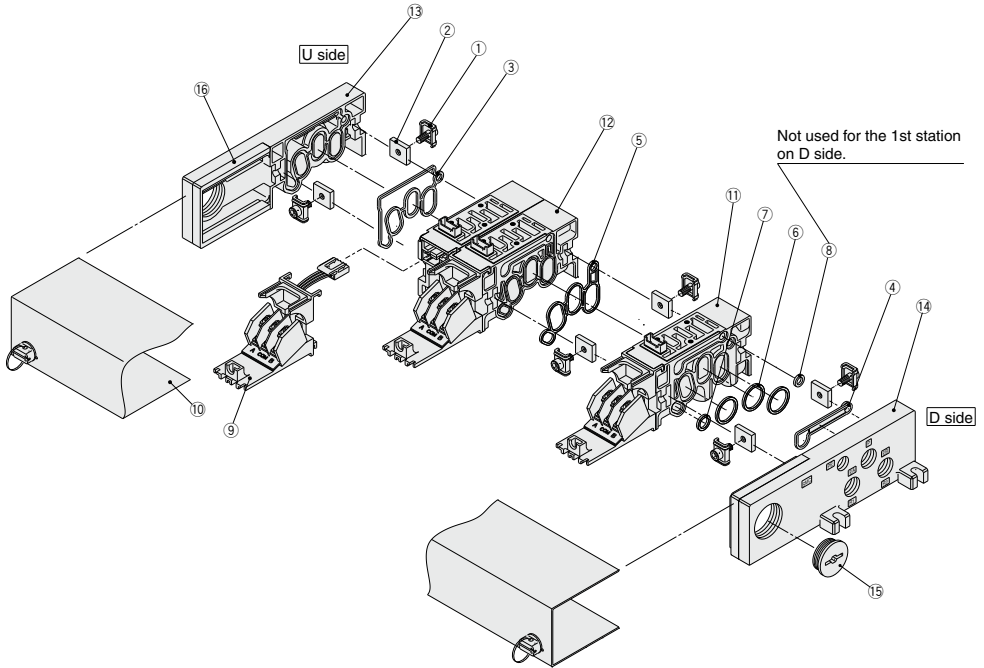

\* Manifold Base/Construction: Plug-in type with terminal block (01T1).

• For increasing the manifold bases, please order the manifold block assembly number of the principle number assembly ① and ⑫.

• For plug-in type: The manifold base with terminal stand (integrated with a junction cover) is required with the ⑬ junction cover assembly.

• Manifold base is consisted of the junction of 2 and 3 station bases.

Example) U side (n) ⑥ ⑤ ④ ③ ② ① D side

<5 stations (Odd number)> 2 stations | 2 stations | 1 station

<6 stations (Even number)> 2 stations | 2 stations | 1 station | 1 station

Note) When A and B ports are C6 or C8, the manifold base is consisted of 1 station base.

# 5 Port Pilot Operated Solenoid Valve Rubber Seal, Plug-in/Non Plug-in **VFR2000 Series**

## Replacement Parts

No.	Description	Material	Part no.
1	Connection fitting assembly	Steel plate	AXT625-4-1A
2	Connection fitting B	Steel plate	AXT625-5
3	Gasket A	NBR	AXT625-17
4	Gasket B	NBR	AXT625-16
5	Gasket	HNBR	VVFS2000-32-1H
6	O-ring	NBR	KA00292H
7	O-ring	NBR	KA00276H
8	O-ring	NBR	KA00326H
9	Adapter plate	Resin	For 01 AXT625-6
	Adapter plate assembly	—	For 01T For 01T1 AXT625-28-13A (Terminal section with adapter plate and lead wire assembly)
	Adapter plate	Resin	For 01C For 01F AXT625-28-1 VVF2000-26-6
10	Junction cover assembly	—	For 01 AXT625-7A
			For 01T AXT625-28-3A
			For 01T1 AXT625-28-7A- <span style="border: 1px solid black; padding: 0 2px;">Stations</span>
			For 01C VVF2000-26-5A- <span style="border: 1px solid black; padding: 0 2px;">Stations</span>
			For 01F
15	Rubber plug	NBR	For 01 AXT333-12
			For 01T (1) AXT625-22
16	Guard	Resin	For $\frac{01}{01T(1)}$ AXT625-28-4

## Replacement Parts: Sub Assembly

No.	Description	Part no.	Component parts	Applicable manifold base
11	Manifold block assembly (for 1 station)	AXT625-01A- $\frac{1}{2}$ C <sub>8</sub> (-B) <sup>1</sup> Note	Manifold block ①, Metal joint ①, ②, O-ring ⑥, ⑦, ⑧, Junction cover ⑩, Adapter plate ⑨, Pin housing, Guide, Insert plug lead wire	Plug-in type With attachment plug lead wire
		AXT625-20A- $\frac{1}{2}$ C <sub>8</sub> (-B) <sup>1</sup> Note	Manifold block ①, Metal joint ①, ②, O-ring ⑥, ⑦, ⑧, Junction cover ⑩, Adapter plate assembly (with terminal) ⑨, Pin housing, Guide	Plug-in type With terminal block
		AXT625-10A- $\frac{1}{2}$ C <sub>8</sub> (-B) <sup>1</sup> Note	Manifold block ①, Metal joint ①, ②, O-ring ⑥, ⑦, ⑧	Non plug-in type
12	Manifold block assembly (for 2 stations)	AXT625-01A2- $\frac{1}{2}$ <sup>1</sup> Note	Manifold block ⑫, Metal joint ①, ②, Gasket ⑤, Junction cover ⑩, Adapter plate ⑨, Pin housing, Guide, Insert plug lead wire	Plug-in type With attachment plug lead wire
		AXT625-20A2- $\frac{1}{2}$ <sup>1</sup> Note	Manifold block ⑫, Metal joint ①, ②, Gasket ⑤, Junction cover ⑩, Adapter plate assembly (with terminal) ⑨, Pin housing, Guide	Plug-in type With terminal block
		AXT625-10A2- $\frac{1}{2}$ <sup>1</sup> Note	Manifold block ①, Metal joint ①, ②, Gasket ⑤	Non plug-in type
13	End plate (U side) assembly	AXT625-2A	End plate (U) ⑬, Metal joint ①, ②, Gasket A ③, Guard ⑯	Plug-in type With attachment plug lead wire
		AXT625-2A-20	End plate (U) ⑬, Metal joint ①, ②, Gasket A ③, Guard ⑯	Plug-in type With terminal block
		AXT625-2A-10	End plate (U) ⑬, Metal joint ①, ②, Gasket A ③	Non plug-in type
14	End plate (D side) assembly	AXT625-3A	End plate (D) ⑭, Metal joint ①, ②, Gasket B ④, Guard ⑯, Steel ball	Plug-in type With attachment plug lead wire
		AXT625-3A-20	End plate (D) ⑭, Metal joint ①, ②, Gasket B ④, Guard ⑯, Steel ball	Plug-in type With terminal block
		AXT625-3A-10	End plate (D) ⑭, Metal joint ①, ②, Gasket B ④, Steel ball	Non plug-in type

Note) 1: A, B port size Rc 1/8, 2: A, B port size Rc 1/4, (-B): A, B port bottom ported

SV

SYJ

SZ

VF

VP4

VQ

1/2

VQ

4/5

VQC

1/2

VQC

4/5

VQZ

SQ

VFS

VFR

VQ7

# 5 Port Pilot Operated Solenoid Valve Rubber Seal, Plug-in/Non Plug-in VFR3000 Series



[Option] Note



NRTL / C  
(Details→P.1106)

Note) Applicable only for DIN terminal and plug-in types.  
For details, refer to "How to Order".



Plug-in type



Non plug-in type

## Symbol

2 position	3 position
Single	Closed center
(A)4 2(B)  (EA)5 1 3(EB) (P)	(A)4 2(B)  (EA)5 1 3(EB) (P)
Double	Exhaust center
(A)4 2(B)  (EA)5 1 3(EB) (P)	(A)4 2(B)  (EA)5 1 3(EB) (P)
	Pressure center
	(A)4 2(B)  (EA)5 1 3(EB) (P)

## Standard Specifications

Valve specifications		Fluid	Air
Operating pressure range	2 position single/3 position		0.2 to 0.9 MPa
	2 position double		0.1 to 0.9 MPa
Ambient and fluid temperature			-10 to 50°C (No freezing.)
Lubrication			Not required <sup>(1)</sup>
Manual override			Non-locking push type
Mounting orientation			Unrestricted
Impact/Vibration resistance			300/50 m/s <sup>2</sup> <sup>(2)</sup>
Enclosure			Dustproof
Coil rated voltage			100, 200 VAC (50/60 Hz), 24 VDC
Allowable voltage fluctuation			-15 to +10% of rated voltage
Apparent power (AC) <sup>(3)</sup>	Inrush		5.6 VA/50 Hz, 5.0 VA/60 Hz
	Holding		3.4 VA (2.1 W)/50 Hz, 2.3 VA (1.5 W)/60 Hz
Power consumption (DC) <sup>(3)</sup>			1.8 W (2.04 W: With light/surge voltage suppressor)
Electrical entry		Plug-in type	Conduit terminal
		Non plug-in type	Grommet, Grommet terminal Conduit terminal, DIN terminal

Note 1) Use turbine oil Class 1 (ISO VG32), if lubricated.

Note 3) At rated voltage

Note 2) Impact resistance: No malfunction occurred when it is tested with a drop tester in the axial direction and at the right angles to the main valve and armature in both energized and de-energized states every once for each condition. (Values at the initial period)

Vibration resistance: No malfunction occurred in a one-sweep test between 45 and 2000 Hz.

Test was performed at both energized and de-energized states in the axial direction and at the right angles to the main valve and armature. (Values at the initial period)

## Option Specifications

Pilot type		External pilot <sup>Note)</sup>
Manual override	Main valve	Direct manual override
	Pilot valve	Non-locking push type A (Extended), Locking type B (Tool required), Locking type C (Lever)
Coil rated voltage		110 to 120, 220, 240 VAC 50/60 Hz 12 VDC
Porting specifications		Bottom ported
Option		With light/surge voltage suppressor

Note) Operating pressure: 0 to 0.9 MPa

Pilot pressure: 2 position single/3 position 0.2 to 0.9 MPa

2 position double 0.1 to 0.9 MPa

## Model

Type of actuation	Model	Port size Rc	Flow rate characteristics <sup>(1)</sup>						Max. operating cycle (Hz) <sup>(2)</sup>	Response time (ms) <sup>(3)</sup>	Weight (kg) <sup>(4)</sup>		
			1 → 4/2 (P → A/B)			4/2 → 5/3 (A/B → EA/EB)							
			C [dm <sup>3</sup> /(s·bar)]	b	Cv	C [dm <sup>3</sup> /(s·bar)]	b	Cv					
2 position	Single	VFR310□	VFR311□	1/4	7.5	0.38	1.9	7.5	0.34	1.9	5	30 or less	0.61 (0.64) <0.58>
		VFR310□	VFR314□	3/8	8.4	0.39	2.2	8.7	0.38	2.2			
2 position	Double	VFR320□	VFR321□	1/4	7.1	0.41	1.9	7.4	0.40	1.9	5	30 or less	0.71 (0.74) <0.69>
		VFR320□	VFR324□	3/8	7.9	0.36	2.0	8.6	0.37	2.2			
3 position	Closed center	VFR330□	VFR331□	1/4	6.8	0.40	1.8	6.3	0.38	1.6	3	50 or less	0.72 (0.75) <0.71>
		VFR330□	VFR334□	3/8	7.2	0.39	1.9	6.5	0.40	1.7			
	Exhaust center	VFR340□	VFR341□	1/4	6.5	0.42	1.7	7.9 [3.4]	0.41 [0.47]	2.0 [0.96]	3	50 or less	0.75 (0.75) <0.71>
		VFR340□	VFR344□	3/8	6.9	0.42	1.8	9.5 [3.4]	0.39 [0.46]	2.4 [0.96]			
	Pressure center	VFR350□	VFR351□	1/4	7.6 [2.4]	0.33 [0.48]	1.9 [0.69]	6.1	0.36	1.5	3	50 or less	0.72 (0.75) <0.71>
VFR350□	VFR354□	3/8	9.3 [2.4]	0.34 [0.47]	2.2 [0.69]	6.5	0.41	1.7					

Note 1) [ ] : Denotes the normal position.

Note 2) Min. operating frequency is once in 30 days.

Note 3) Based on dynamic performance test, JIS B 8419: 2010. (0.5 MPa, Coil temperature: 20°C, at rated voltage, without surge voltage suppressor)

Note 4) For VFR3□0□-FZ-□, ( ): VFR3□10-DZ-□, < >: VFR3□40-CG-□

# 5 Port Pilot Operated Solenoid Valve Rubber Seal, Plug-in/Non Plug-in **VFR3000 Series**

Note) Electrical entry and light/surge voltage suppressor: D/DZ/DO/DOZ, Y/YZ/YO/YOZ, F, FZ only.



## How to Order

**Electrical entry**

F: Plug-in type, conduit terminal

CE-compliant

**Option**

Nil	None
Z	With light/surge voltage suppressor

**Porting specifications (P, A, EA, EB port)**

Nil	Side ported
B	Bottom ported *

\* Semi-standard

**Thread type**

Nil	Rc
F	G
N	NPT
T	NPTF

**CE-compliant**

Nil	—
Q	CE-compliant (Note)

Note) Electrical entry and light/surge voltage suppressor: D/DZ/DO/DOZ, Y/YZ/YO/YOZ, F, FZ only.

**Plug-in** VFR3 1 0 0 - 5 F - - - 02 - -

**Non plug-in** VFR3 1 1 1 - 1 D - - - 02 - -

**Non plug-in** VFR3 1 4 0 - 1 G - - - 02 - -

**Port size (P, A, B, EA, EB port)**

Nil	Without sub-plate
02	1/4
03	3/8

\* For bottom ported: Rc 1/4

**Common electrical entry Individual electrical entry**

**Pilot valve manual override**

Nil: Non-locking push type

A \*: Non-locking push type A (Extended)

B \*: Locking type B (Tool required)

C \*: Locking type C (Lever)

\* Semi-standard

**Body option**

0	Standard
1 *	Direct manual override

\* Semi-standard

**Pilot type**

Nil	Internal pilot
R	External pilot

**Coil rated voltage**

1	100 VAC, 50/60 Hz
2	200 VAC, 50/60 Hz
3	110 to 120 VAC, 50/60 Hz
4	220 VAC, 50/60 Hz
5	24 VDC
6	12 VDC
7	240 VAC, 50/60 Hz

For other rated voltages, please consult with SMC.

**Option/VFR3□1□**

Nil	None
Z	With light/surge voltage suppressor

**Option/VFR3□4□**

Nil	None
Z *	With light/surge voltage suppressor
S *	With surge voltage suppressor

\* Indicator light is not available for grommet type. With surge voltage suppressor is available for grommet type only.

**Electrical entry: VFR3□1□**

E: Grommet terminal	D: DIN terminal
DO: DIN terminal without connector	

CE-compliant

**Electrical entry: VFR3□4□**

G: Grommet	E: Grommet terminal	T: Conduit terminal	D, Y: DIN terminal
			DO, YO: DIN terminal without connector

CE-compliant

SV
SYJ
SZ
VF
VP4
VQ 1/2
VQ 4/5
VQC 1/2
VQC 4/5
VQZ
SQ
VFS
VFR
VQ7

## How to Order Pilot Valve Assembly

SF4- 1 F - - - 70 - - -

**Coil rated voltage**

Symbol	Rated voltage
1	100 VAC, 50/60 Hz
2	200 VAC, 50/60 Hz
3	110 to 120 VAC, 50/60 Hz
4	220 VAC, 50/60 Hz
5	24 VDC
6	12 VDC
7	240 VAC, 50/60 Hz

For other rated voltages, please consult with SMC.

**Electrical entry, Light/Surge voltage suppressor**

Symbol	Electrical entry	indicator light	With surge voltage suppressor	Applicable valve model	CE-compliant
F *	Plug-in	—	—	VFR3□□□ VFR3□1□□	●
G	Grommet	—	●	—	—
GS	Grommet	—	●	—	—
E	Grommet terminal	●	●	—	—
EZ	Grommet terminal	●	●	—	—
T	Conduit terminal	●	●	—	—
DZ	DIN terminal	●	●	VFR3□□□	●
DO	DIN terminal	●	●	—	●
DOZ	DIN terminal	●	●	—	●
Y	DIN terminal	●	●	—	●
YZ	DIN terminal	●	●	—	●
YO	DIN terminal	●	●	—	●
YOZ	DIN terminal	●	●	—	●

**Manual override**

Nil	Non-locking push type
A	Non-locking push type A (Extended)
B	Locking type B (Tool required)
C	Locking type C (Lever)

\* VFR3□□□, "VFR3□1□□": Pilot valve assembly is all plug-in (F).

**Symbol**

Symbol	Applicable valve model
Nil	VFR3□□□
1	VFR3□1□□

**CE-compliant**

Nil	—
Q	CE-compliant (Note)

Note) Electrical entry and light/surge voltage suppressor: D/DZ/DO/DOZ, Y/YZ/YO/YOZ, F only.





# VFR3000 Series

Use as a guide for selection.  
Please confirm the actual conditions with SMC Sizing Program.

## Cylinder Speed Chart

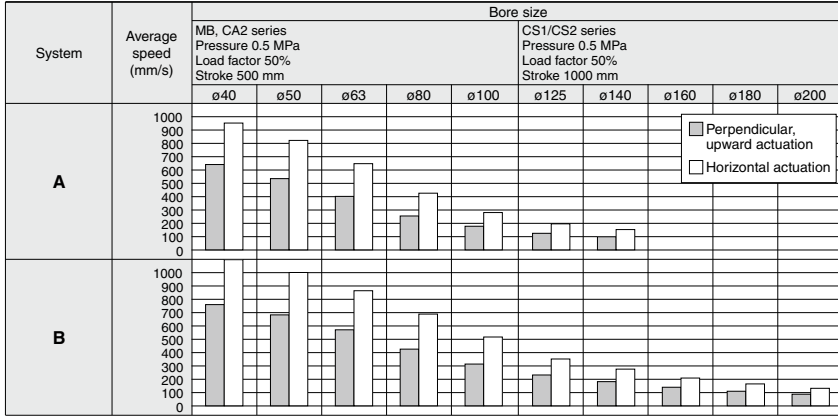

- \* It is when the cylinder is extending that is meter-out controlled by speed controller which is directly connected with cylinder, and its needle valve with being fully open.
- \* The average velocity of the cylinder is what the stroke is divided by the total stroke time.
- \* Load factor: ((Load mass x 9.8)/Theoretical force) x 100%

## System Components

System	Solenoid valve	Speed controller	Silencer	SPG (Steel pipe) dia. x Length
A	VFR3000 Series Rc 1/4	AS4000-02	AN20-02	6A x 1 m
B	VFR3000 Series Rc 3/8	AS420-03	AN30-03	10A x 1 m

## How to Order Sub-plate Assembly

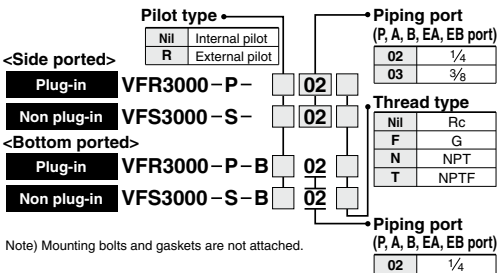

# 5 Port Pilot Operated Solenoid Valve Rubber Seal, Plug-in/Non Plug-in **VFR3000 Series**

## Construction

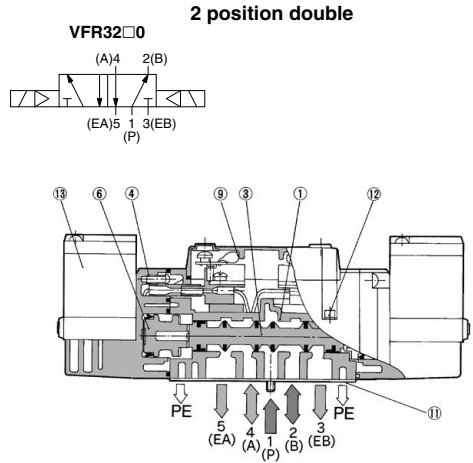
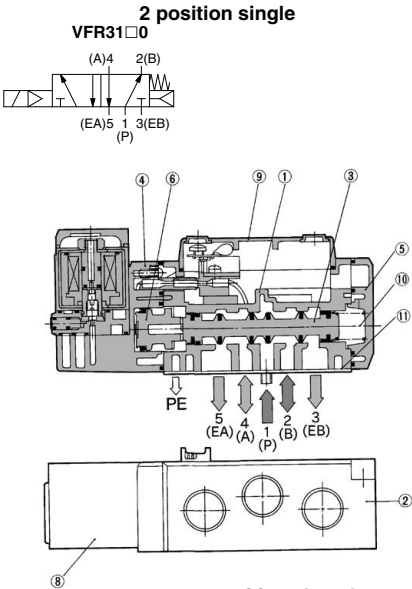

### 3 position closed center/exhaust center/pressure center

**Closed center: VFR33□□**

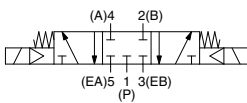

**Exhaust center: VFR34□□**

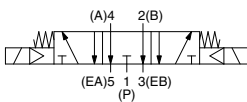

**Pressure center: VFR35□□**

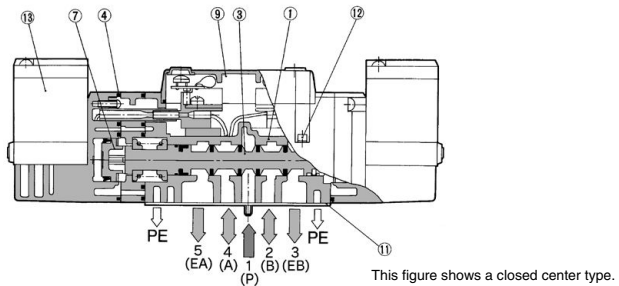
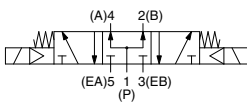

### Component Parts

No.	Description	Material	Note
1	Body	Aluminum die-casted	Platinum silver
2	Sub-plate	Aluminum die-casted	Platinum silver
3	Spool valve	Aluminum, NBR	
4	Adapter plate	Resin	Black
5	End plate	Resin	Black

### Component Parts

No.	Description	Material	Note
6	Piston	Resin	
7	Piston	Resin	
8	Junction cover	Resin	
9	Light cover	Resin	
10	Return spring	Stainless steel	

### Replacement Parts

No.	Description	Material	Description		
			VFR31□□	VFR32□□	VFR33□□/34□□/35□□
11	Gasket	NBR	VFR3000-26-4	VFR3000-26-4	VFR3000-26-4
12	Hexagon socket head screw <sup>(Note)</sup>	Steel	AXT632-3#1 (M3 x 32)	AXT632-3#1 (M3 x 32)	AXT632-3#1 (M3 x 32)
13	Pilot valve assembly	—	Refer to "How to Order Pilot Valve Assembly" on page 1039.		
—	Sub-plate assembly	—	Refer to "How to Order Sub-plate Assembly" on page 1040.		

Note) For the VFR3000 series, it requires 3 pcs.



SV
SYJ
SZ
VF
VP4
VQ 1/2
VQ 4/5
VQC 1/2
VQC 4/5
VQZ
SQ
VFS
VFR
VQ7

# VFR3000 Series

## Plug-in: 2 Position Single/Double, 3 Position Closed Center/Exhaust Center/Pressure Center

### 2 position single: VFR310 $\frac{1}{2}$ -□FZ

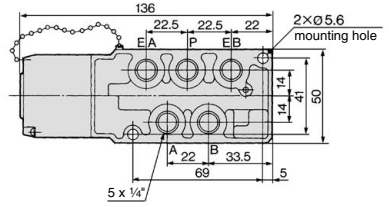
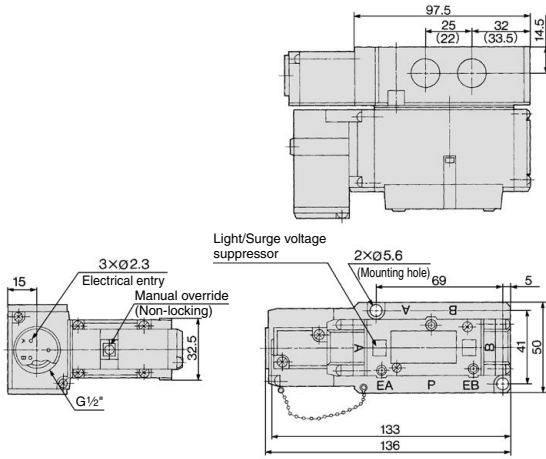

Bottom ported

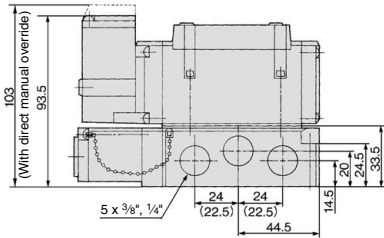
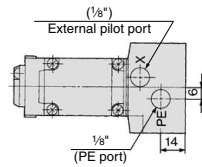
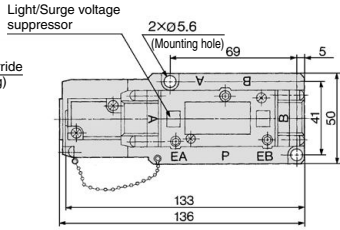
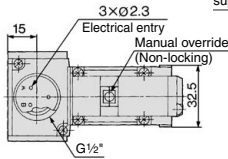

( ) : Rc 1/4

### 2 position single: VFR320 $\frac{1}{2}$ -□FZ

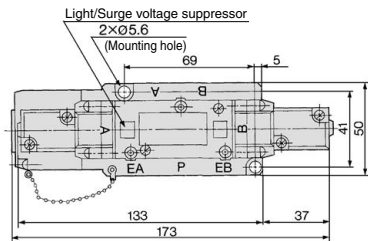

\* Other dimensions are the same as the single type.

### 3 position closed center: VFR330 $\frac{1}{2}$ -□FZ

### 3 position exhaust center: VFR340 $\frac{1}{2}$ -□FZ

### 3 position pressure center: VFR350 $\frac{1}{2}$ -□FZ

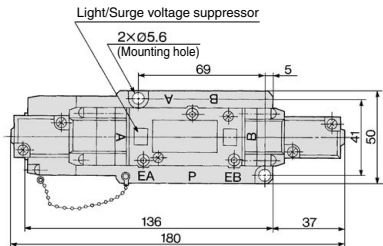

\* Other dimensions are the same as the single type.

5 Port Pilot Operated Solenoid Valve  
 Rubber Seal, Plug-in/Non Plug-in **VFR3000 Series**

**Non Plug-in: 2 Position Single/Double, 3 Position Closed Center/Exhaust Center/Pressure Center**

2 position single: VFR311  $\frac{1}{2}$ -□E, VFR311  $\frac{1}{2}$ -□DZ

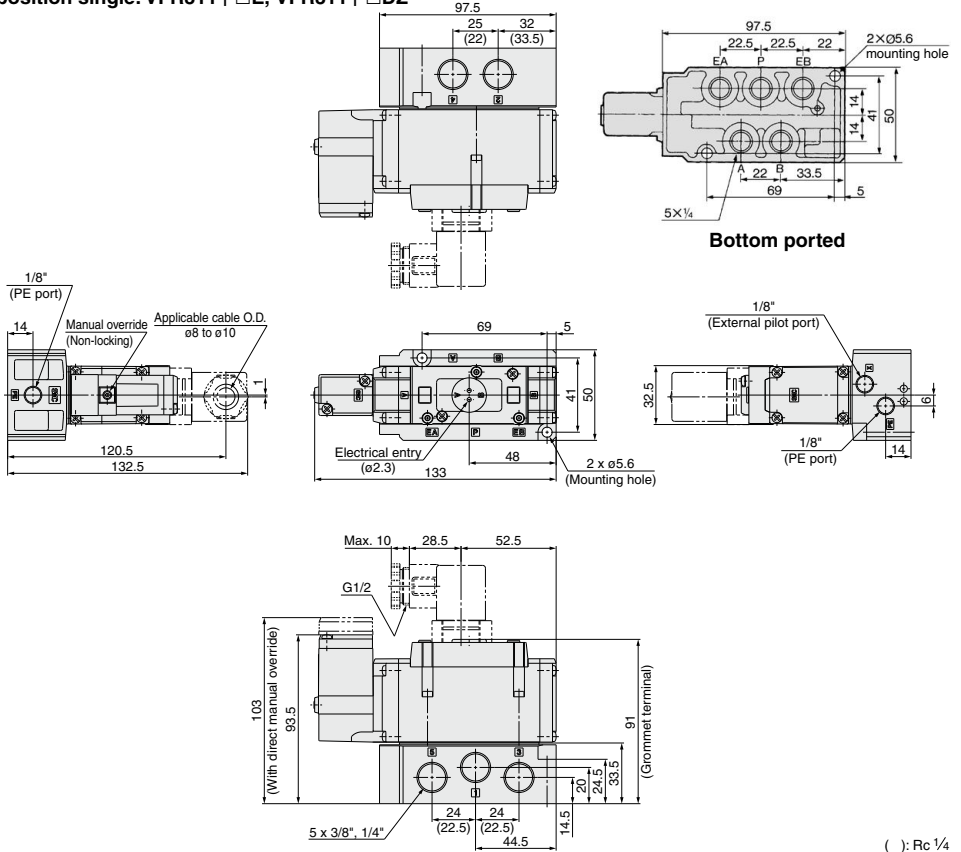

SV
SYJ
SZ
VF
VP4
VQ 1/2
VQ 4/5
VQC 1/2
VQC 4/5
VQZ
SQ
VFS
VFR
VQ7

2 position double: VFR321  $\frac{1}{2}$ -□E, VFR321  $\frac{1}{2}$ -□DZ

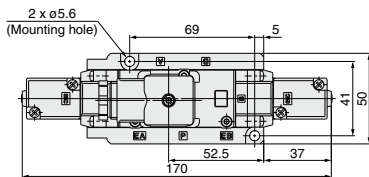

3 position closed center: VFR331  $\frac{1}{2}$ -□E, VFR341  $\frac{1}{2}$ -□DZ  
 3 position exhaust center: VFR341  $\frac{1}{2}$ -□E, VFR341  $\frac{1}{2}$ -□DZ  
 3 position pressure center: VFR351  $\frac{1}{2}$ -□E, VFR351  $\frac{1}{2}$ -□DZ

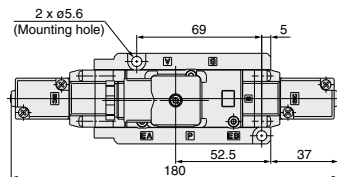

\* Other dimensions are the same as the single type.

\* Other dimensions are the same as the single type.



# VFR3000 Series

## Non Plug-in: 2 Position Single

2 position single: VFR314 □ □ G

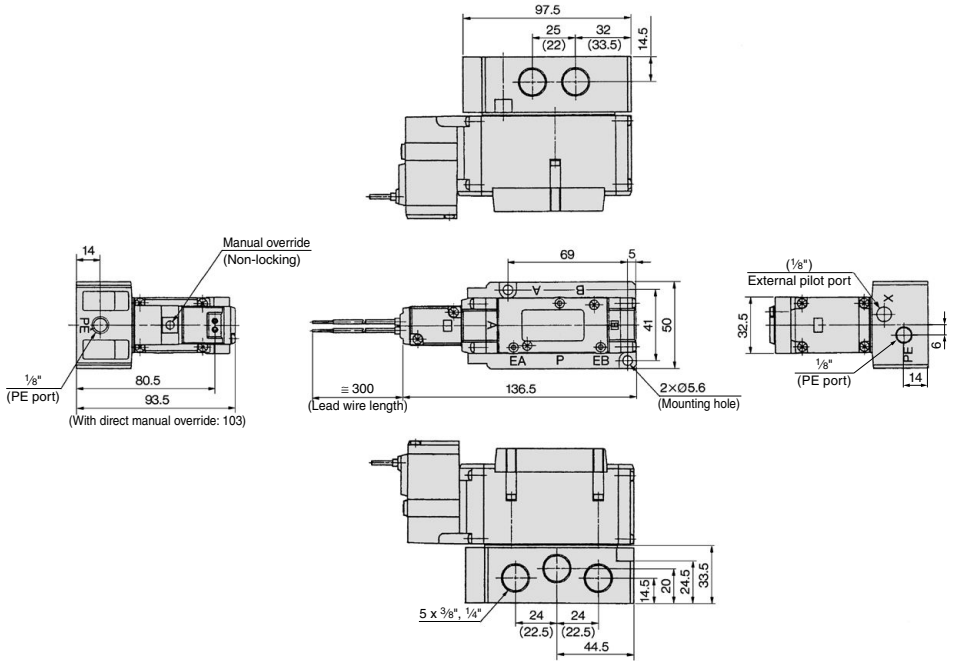

( ) : Rc 1/4

### E: Grommet terminal

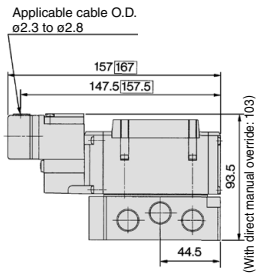

With light/surge voltage suppressor

### T: Conduit terminal

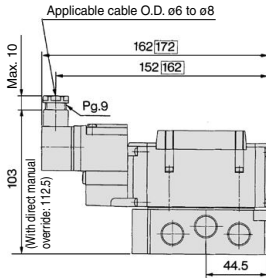

With light/surge voltage suppressor

### D, Y: DIN terminal

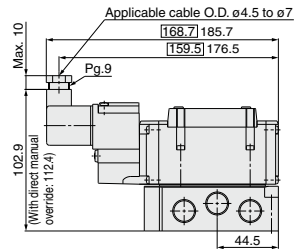

With light/surge voltage suppressor

# 5 Port Pilot Operated Solenoid Valve Rubber Seal, Plug-in/Non Plug-in **VFR3000 Series**

## Non Plug-in: 2 Position Double, 3 Position Closed Center/Exhaust Center/Pressure Center

2 position double: VFR324  $\frac{0}{1}$ -□G

3 position closed center: VFR334  $\frac{0}{1}$ -□G

3 position exhaust center: VFR344  $\frac{0}{1}$ -□G

3 position pressure center: VFR354  $\frac{0}{1}$ -□G

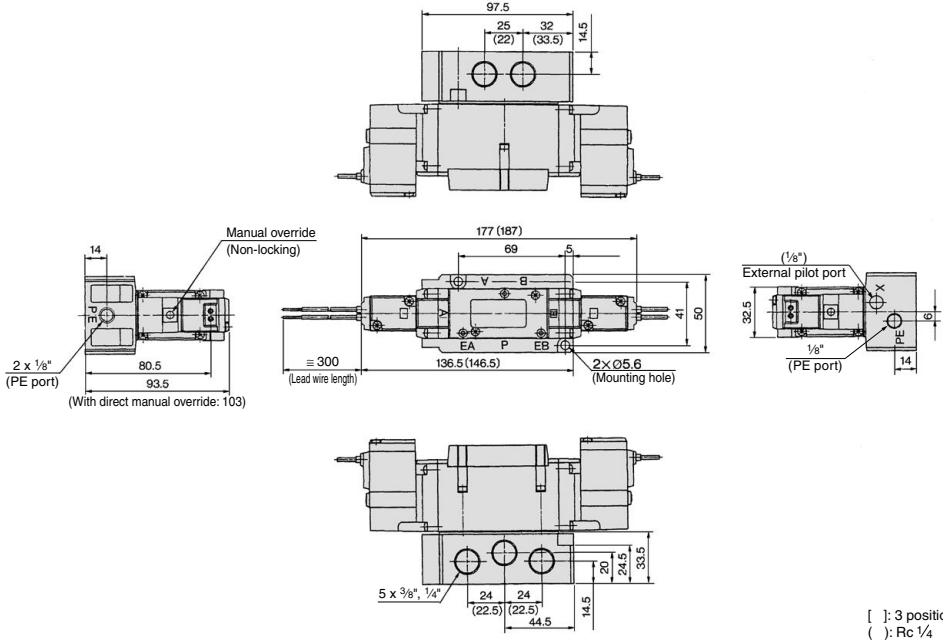

SV
SYJ
SZ
VF
VP4
VQ 1/2
VQ 4/5
VQC 1/2
VQC 4/5
VQZ
SQ
VFS
VFR
VQ7

### E: Grommet terminal

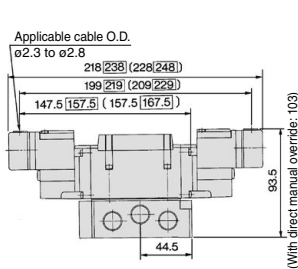

[ ] : 3 position  
 □ : With light/surge voltage suppressor

### T: Conduit terminal

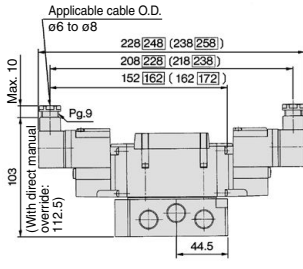

[ ] : 3 position  
 □ : With light/surge voltage suppressor

### D, Y: DIN terminal

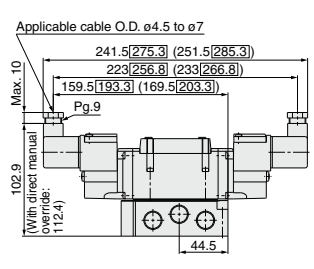

[ ] : 3 position  
 □ : With light/surge voltage suppressor

# VFR3000 Series Manifold Specifications

## Manifold Specifications

Base mounted	Wiring	Porting specifications		Port size		Stations	Applicable valve model	
		A, B port	P, EA, EB	A, B				
Plug-in type <b>VV5FR3-01□(-Q)</b>	<ul style="list-style-type: none"> <li>With terminal block</li> <li>With multi-connector</li> <li>With D-sub connector</li> </ul>	Side/Bottom	Note) 1/2	1/4, 3/8 C8, C10	2 to 10	VFR3□□□□(-Q)		
Non plug-in type <b>VV5FR3-10(-Q)</b>	<ul style="list-style-type: none"> <li>Grommet terminal</li> <li>DIN terminal</li> </ul>						2 to 10	VFR3□1□□(-E) VFR3□1□□(-D(-Q))
Non plug-in type <b>VV5FR3-40(-Q)</b>	<ul style="list-style-type: none"> <li>Grommet</li> <li>Grommet terminal</li> <li>Conduit terminal</li> <li>DIN terminal</li> </ul>							

Note) If silencer is mounted to EA/EB port, use silencer "AN403-04" (O.D. ø27).

## How to Order Manifold Assembly

<Example> Plug-in type with terminal block: 6 stations

VV5FR3-01T-061-02 (-Q) ..... 1 set (Manifold base part no.)  
 \*VFR3100-5FZ (-Q) ..... 3 sets (2 position single part no.)  
 \*VFR3200-5FZ (-Q) ..... 2 sets (2 position double part no.)  
 \*VVFS3000-10A ..... 1 set (Blanking plate)

The asterisk denotes the symbol for assembly. Prefix it to the part nos. of the solenoid valve, etc.

Valve arrangement is counted from the D side.

When ordering, specify the part nos. in order from the 1st. station in the D side.

When entry of part numbers becomes complicated, indicate on the manifold specification sheet.

<Example> Non plug-in type: 6 stations

VV5FR3-10-061-03 (-Q) ..... 1 set (Manifold base part no.)  
 \*VFR3110-5D (-Q) ..... 5 sets (2 position single part no.)  
 \*VFR3410-5D (-Q) ..... 1 set (3 position exhaust center part no.)  
 \*VVFS3000-R-03-2 ..... 1 set (Individual EXH spacer part no.)

The asterisk denotes the symbol for assembly. Prefix it to the part nos. of the solenoid valve, etc.

Valve arrangement is counted from the D side.

When ordering, specify the part nos. in order from the 1st. station in the D side.

When entry of part numbers becomes complicated, indicate on the manifold specification sheet.



## Plug-in Type: With Terminal Block

- Since lead wires of solenoid valve are connected with the terminals on upper surface of terminal block, corresponding lead wires from power source can be wired at the bottom of terminal block.

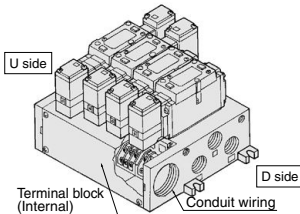

**VV5FR3 - 01T - 06 1 - 02**

VFR3000 Series Manifold

Plug-in type with terminal block

**CE-compliant**

NH	—
Q	CE-compliant

**Symbol**

Symbol	Passage		Porting specifications (A, B)
	P	EA, EB	
1	Common	Common	Side
2	Common	Common	Bottom *

\* Semi-standard

**Stations**

02	2 stations
:	:
10	10 stations

**Port size**

Symbol	P, EA, EB	A, B *
02	1/2	1/4
03		3/8
C8		One-touch fitting for ø8
C10	One-touch fitting for ø10	
M	Mixed	

\* For bottom ported: Rc 1/4, 3/8 only.  
 \* For C8 and C10, the thread type is only Rc.

**Thread type**

Symbol	Rc
NH	—
F	G
T	NPTF

## Plug-in Type: With Multi-connector (For wiring specifications, refer to page 1113.)

- Master connection of power and solenoid valves.
- Quick wiring permits ease of installation.

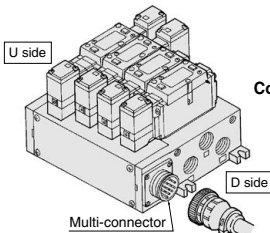

**VV5FR3 - 01C D - 05 1 - 02**

VFR3000 Series Manifold

Plug-in type with multi-connector

**CE-compliant**

NH	—
Q	CE-compliant

**Symbol**

Symbol	Passage		Porting specifications (A, B)
	P	EA, EB	
1	Common	Common	Side
2	Common	Common	Bottom *

\* Semi-standard

**Stations**

02	2 stations
:	:
08	8 stations

\* Max: 8 stations

**Port size**

Symbol	P, EA, EB	A, B *
02	1/2	1/4
03		3/8
C8		One-touch fitting for ø8
C10	One-touch fitting for ø10	
M	Mixed	

\* For bottom ported: Rc 1/4, 3/8 only.  
 \* For C8 and C10, the thread type is only Rc.

**Thread type**

Symbol	Rc
NH	—
F	G
T	NPTF

**Connector mounting direction**

D	D side mounting
U	U side mounting



Note) Electrical entry and light/surge voltage suppressor: D/DZ/DO/DOZ, Y/YZ/YO/YOZ, F, FZ only.



## Plug-in Type: With D-sub Connector (For wiring specifications, refer to page 1113.)

- Wide range of interchangeability (25 pin D-sub connector conforms to MIL standard)
- Quick wiring permits easier installation.

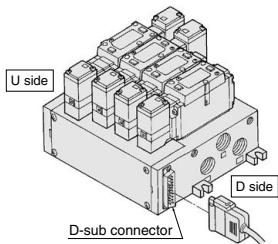

**VV5FR3-01F D-06 1-02**

VFR3000 Series Manifold  
Plug-in type with D-sub connector

**Connector mounting direction**

D	D side mounting
U	U side mounting

**Stations**

02	2 stations
:	:
08	* 8 stations

\* Max: 8 stations

### Symbol

Symbol	Passage	Porting specifications (A, B)	Side	Bottom *
1	Common	Common	Side	Bottom *
2	Common	Common	Side	Bottom *

\* Semi-standard

### Port size

Symbol	P, EA, EB	A, B *
02		1/4
03		3/8
C8	1/2	One-touch fitting for ø8
C10		One-touch fitting for ø10
M		Mixed

\* For bottom ported: Rc 1/4, 3/8 only.  
\* For C8 and C10, the thread type is only Rc.

### CE-compliant

Nil	—
Q	CE-compliant

Note) Electrical entry and light/surge voltage suppressor: F, FZ only

### Thread type

Nil	Rc
F	G
T	NPTF

SV

SYJ

SZ

VF

VP4

VQ 1/2

VQ 4/5

VQC 1/2

VQC 4/5

VQZ

SQ

VFS

VFR

VQ7

## Non Plug-in Type: Grommet Terminal, DIN Terminal (Common electrical entry)

- Individual wiring for every valve

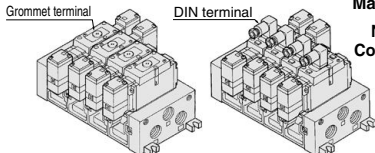

**VV5FR3-10-05 1-02**

VFR3000 Series Manifold  
Non plug-in type  
Common electrical

**Stations**

02	2 stations
:	:
10	10 stations

### Symbol

Symbol	P	EA, EB	Porting specifications (A, B)	Side	Bottom *
1	Common	Common	Common	Side	Bottom *
2	Common	Common	Common	Side	Bottom *

\* Semi-standard

### Port size

Symbol	P, EA, EB	A, B *
02		1/4
03		3/8
C8	1/2	One-touch fitting for ø8
C10		One-touch fitting for ø10
M		Mixed

\* For bottom ported: Rc 1/4, 3/8 only.  
\* For C8 and C10, the thread type is only Rc.

### CE-compliant

Nil	—
Q	CE-compliant

Note) Electrical entry and light/surge voltage suppressor: D/DZ/DO/DOZ, Y/YZ/YO/YOZ only.

### Thread type

Nil	Rc
F	G
T	NPTF

## Non Plug-in Type: Grommet, Grommet Terminal, Conduit Terminal, DIN Terminal (Individual electrical entry)

- Individual wiring for every valve

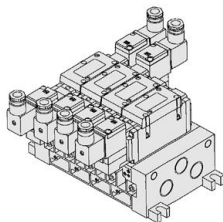

**VV5FR3-40-05 1-02**

VFR3000 Series Manifold  
Non plug-in type  
Individual electrical entry

**Stations**

02	2 stations
:	:
10	10 stations

### Symbol

Symbol	P	EA, EB	Porting specifications (A, B)	Side	Bottom *
1	Common	Common	Common	Side	Bottom *
2	Common	Common	Common	Side	Bottom *

\* Semi-standard

### Port size

Symbol	P, EA, EB	A, B *
02		1/4
03		3/8
C8	1/2	One-touch fitting for ø8
C10		One-touch fitting for ø10
M		Mixed

\* For bottom ported: Rc 1/4, 3/8 only.  
\* For C8 and C10, the thread type is only Rc.

### CE-compliant

Nil	—
Q	CE-compliant

Note) Electrical entry and light/surge voltage suppressor: D/DZ/DO/DOZ, Y/YZ/YO/YOZ only.

### Thread type

Nil	Rc
F	G
T	NPTF

Note) Manifold base is in common with the VFS3000 series.

# VFR3000 Series

## Manifold/Option Parts Assembly

### Individual SUP spacer

Setting individual SUP spacer on the manifold block enables individual SUP port for each valve.

Body type	Plug-in type	Non plug-in type
Part no.	VVFS3000-P-03-1	VVFS3000-P-03-2

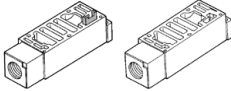

### Individual EXH spacer

Setting individual EXH spacer on the manifold block enables individual EXH port for each valve.

Body type	Plug-in type	Non plug-in type
Part no.	VVFS3000-R-03-1	VVFS3000-R-03-2

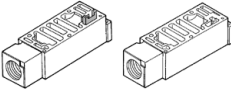

### SUP block disk <sup>Note)</sup>

When supplying manifold with more than two different pressures, high and low, insert a block disk in between stations subjected to different pressures.

Body type	Plug-in type	Non plug-in type
Part no.	AXT636-1A	

### EXH block disk <sup>Note)</sup>

When valve exhaust affects the other stations on the circuit, insert EXH block disk in between stations to separate valve exhaust.

Body type	Plug-in type	Non plug-in type
Part no.	AXT636-1A	



Note) When mounting on the 2 stations integrated manifold block, be sure to mount it only after the gasket has been cut.

### Throttle valve spacer

Needle valve set on the manifold block can control cylinder speed by throttling exhaust.

Body type	Plug-in type	Non plug-in type
Part no.	VVFS3000-20A-1	VVFS3000-20A-2

Shape

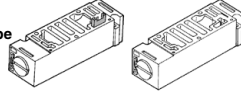

### Interface regulator

Interface regulator set on the manifold block can regulate pressure for each valve. (Refer to "Flow Rate Characteristics" on page 1111 before operation.)

Body type	Plug-in type	Non plug-in type
P port regulation	ARBF3050-00-P-1	ARBF3050-00-P-2
A port regulation	ARBF3050-00-A-1	ARBF3050-00-A-2
B port regulation	ARBF3050-00-B-1	ARBF3050-00-B-2

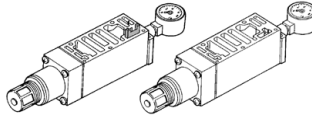

### SUP stop valve spacer

If SUP stop valve spacer is set, valve can be removed for maintenance without stopping air pressure supply for other valves.

Body type	Plug-in type	Non plug-in type
Part no.	VVFS3000-37A-1	VVFS3000-37A-2

(Height will be 27.5 mm higher.)

### Blanking plate

It is used by attaching on the manifold block for being prepared for removing a valve for maintenance reasons or planning to mount a spare valve, etc.

Body type	Plug-in type	Non plug-in type
Part no.	VVFS3000-10A	

\* Mounting screws: 4 positions

## Manifold Option

### With exhaust cleaner

Plug-in type/Non plug-in type

- Valve exhaust noise dampening: 35 dB or more.
- Collects oil mist: collecting rate 99.9% or more
- Piping process reduced.

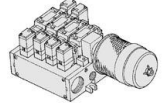

For details, refer to page 1053.

### With control unit

Plug-in type/Non plug-in type

- Filter, regulation valve, pressure switch and air release valve are all combined to form one unit.
- Piping processes are eliminated.

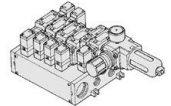

For details, refer to page 1056.

# 5 Port Pilot Operated Solenoid Valve Rubber Seal, Plug-in/Non Plug-in **VFR3000 Series**

## Manifold: Plug-in Type

With terminal block: **VV5FR3-01T-Station 1-Port size**

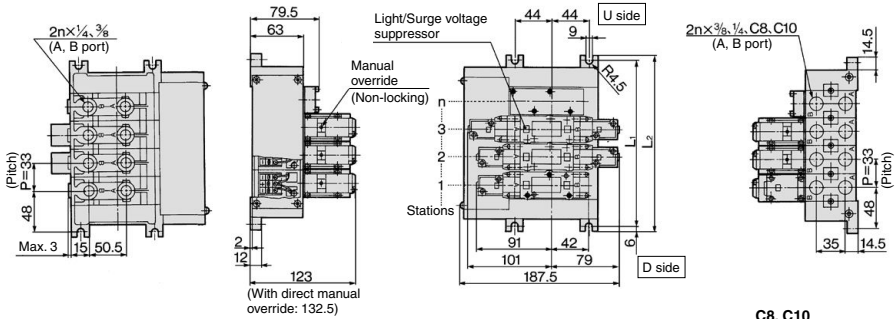

**Bottom ported:**  
**VV5FR3-01T-Station 2-Port size**

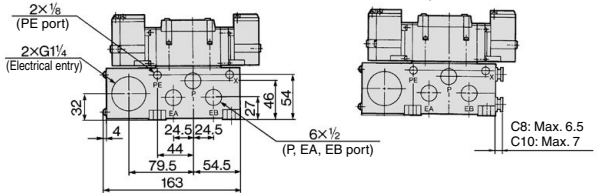

		n: Station									
L	Station	2	3	4	5	6	7	8	9	10	Formula
L <sub>1</sub>		129	162	195	228	261	294	327	360	393	L <sub>1</sub> = 33 x n + 63
L <sub>2</sub>		141	174	207	240	273	306	339	372	405	L <sub>2</sub> = 33 x n + 75

With multi-connector: **VV5FR3-01CD-Station 1-Port size**, **VV5FR3-01CU-Station 1-Port size**

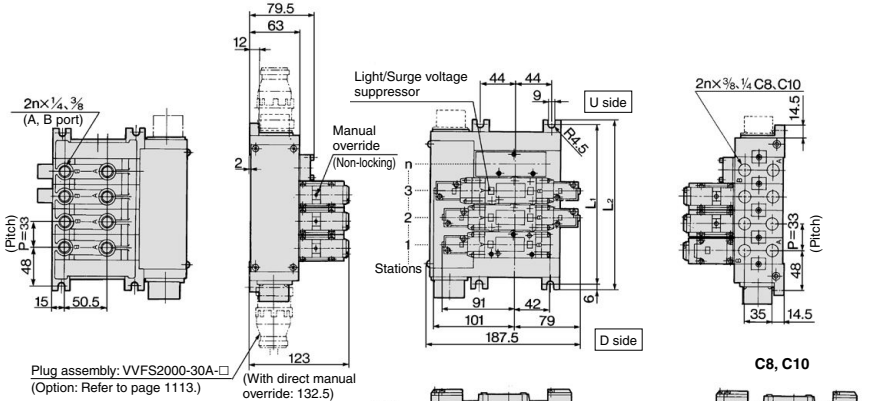

		n: Station									
L	Station	2	3	4	5	6	7	8	9	10	Formula
L <sub>1</sub>		129	162	195	228	261	294	327	360	393	L <sub>1</sub> = 33 x n + 63
L <sub>2</sub>		141	174	207	240	273	306	339	372	405	L <sub>2</sub> = 33 x n + 75

- SV
- SYJ
- SZ
- VF
- VP4
- VQ 1/2
- VQ 4/5
- VQC 1/2
- VQC 4/5
- VQZ
- SQ
- VFS
- VFR
- VQ7



# VFR3000 Series

## Manifold: Plug-in Type

With D-sub connector: VV5FR3-01FD-Station 1-Port size, VV5FR3-01FU-Station 1-Port size

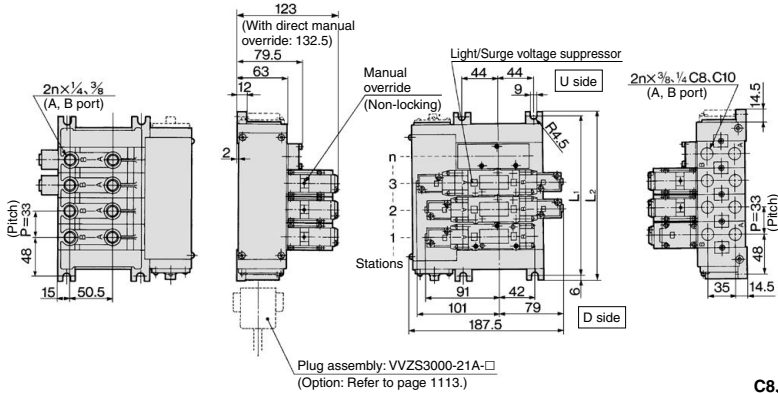

C8, C10

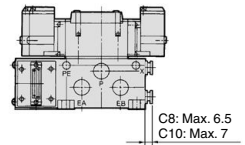

For wiring specifications, refer to page 1113.

L	2	3	4	5	6	7	8	Formula
L <sub>1</sub>	129	162	195	228	261	294	327	L <sub>1</sub> = 33 x n + 63
L <sub>2</sub>	141	174	207	240	273	306	339	L <sub>2</sub> = 33 x n + 75

n: Station

L<sub>1</sub> = 33 x n + 63  
L<sub>2</sub> = 33 x n + 75

## Manifold: Non Plug-in Type

VV5FR3-10-Station 1-Port size

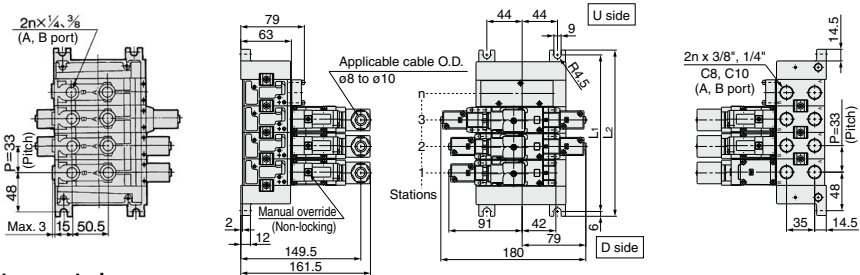

Bottom ported:

VV5FR3-10-Station 2-Port size

C8, C10

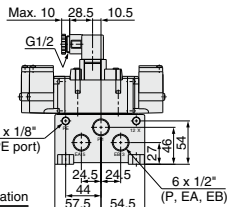
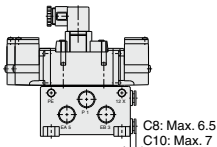

Grommet with terminal

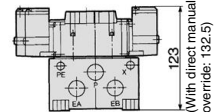

L	2	3	4	5	6	7	8	9	10	Formula
L <sub>1</sub>	129	162	195	228	261	294	327	360	393	L <sub>1</sub> = 33 x n + 63
L <sub>2</sub>	141	174	207	240	273	306	339	372	405	L <sub>2</sub> = 33 x n + 75

n: Station

L<sub>1</sub> = 33 x n + 63  
L<sub>2</sub> = 33 x n + 75

# 5 Port Pilot Operated Solenoid Valve Rubber Seal, Plug-in/Non Plug-in **VFR3000 Series**

## Manifold: Plug-in Type

### VV5FR3-40-Station 1- Port size

G: Grommet

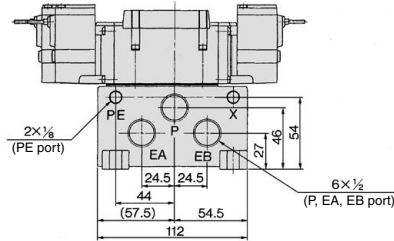
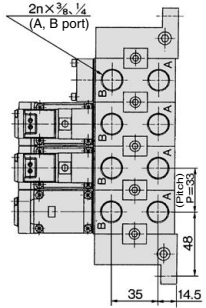
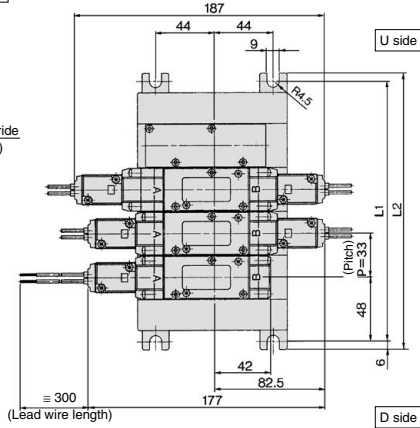
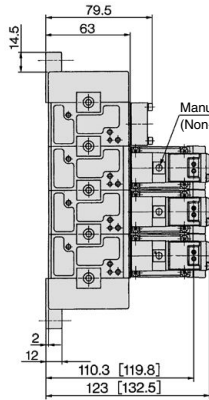

[ ] : With direct manual override

		n: Station									
		2	3	4	5	6	7	8	9	10	Formula
L <sub>1</sub>		129	162	195	228	261	294	327	360	393	L <sub>1</sub> = 33 x n + 63
L <sub>2</sub>		141	174	207	240	273	306	339	372	405	L <sub>2</sub> = 33 x n + 75

### E: Grommet terminal

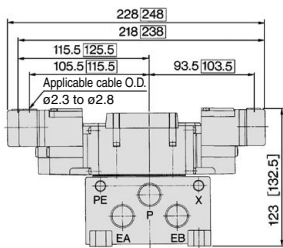

: With light/surge voltage suppressor

### T: Conduit terminal

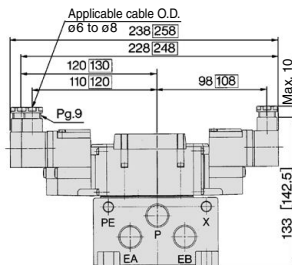

: With light/surge voltage suppressor

### D, Y: DIN terminal

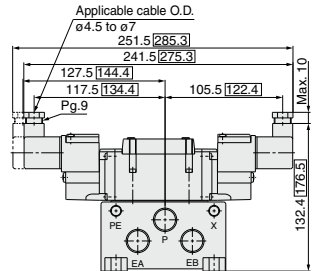

: With light/surge voltage suppressor

- SV
- SYJ
- SZ
- VF
- VP4
- VQ 1/2
- VQ 4/5
- VQC 1/2
- VQC 4/5
- VQZ
- SQ
- VFS
- VFR
- VQ7

# VFR3000 Series

## Manifold/Option Parts Assembly: Plug-in Type/Non Plug-in Type

**Individual SUP spacer:**  
**VVFS3000-P-03-1 (Plug-in type)**  
**VVFS3000-P-03-2 (Non plug-in type)**

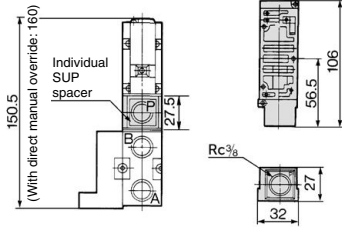

**Individual EXH spacer:**  
**VVFS3000-R-03-1 (Plug-in type)**  
**VVFS3000-R-03-2 (Non plug-in type)**

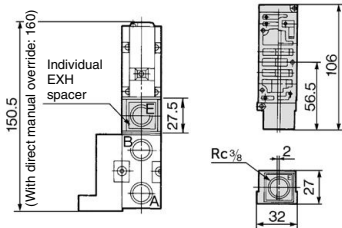

**SUP/EXH block disk: AXT636-1A**

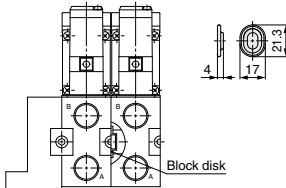

Note) When mounting on the 2 stations integrated manifold block, be sure to mount it only after the gasket has been cut.

**Throttle valve spacer:**  
**VVFS3000-20A-1 (Plug-in type)**  
**VVFS3000-20A-2 (Non plug-in type)**

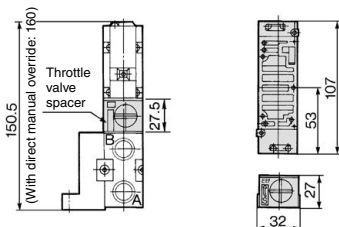

**Interface regulator/P port regulation:**  
**ARBF3050-00-P-1 (Plug-in type)**  
**ARBF3050-00-P-2 (Non plug-in type)**

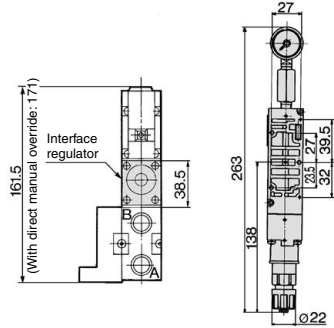

**Interface regulator/A port regulation:**  
**ARBF3050-00-A-1 (Plug-in type)**  
**ARBF3050-00-A-2 (Non plug-in type)**

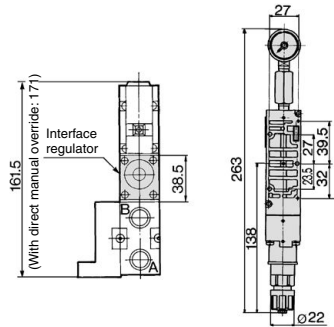

**Interface regulator/B port regulation:**  
**ARBF3050-00-B-1 (Plug-in type)**  
**ARBF3050-00-B-2 (Non plug-in type)**

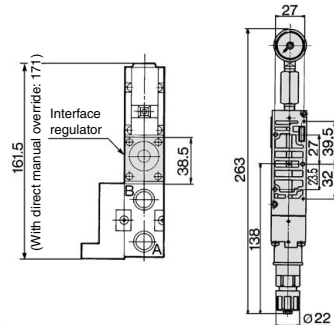

## Manifold with Exhaust Cleaner

- Serves to protect working environment.
- Valve exhaust noise dampening: 35 dB or more.
- Collection rate of drainage and oil mist: 99.9% or more
- Piping work is reduced.

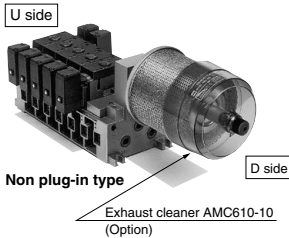
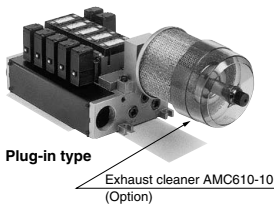

### Manifold Specifications

Manifold	Plug-in type: VV5FR3-01□(-Q)	Non plug-in type: VV5FR3-10(-Q)	Non plug-in type: VV5FR3-40(-Q)
<b>Wiring</b>	With terminal block With multi-connector With D-sub connector	DIN terminal Grommet terminal	Grommet, Grommet terminal Conduit terminal, DIN terminal
<b>Applicable valve model</b>	VFR3□□□□□(-Q)	VFR3□1□□□□(-Q) VFR3□1□□□□(-Q)	VFR3□4□□□□(-Q), VFR3□4□□□□(-Q) VFR3□4□□□□(-Q), VFR3□4□□□□(-Q)
<b>Porting specifications</b>	Common SUP, Common EXH		
<b>Rc</b>	A, B port	Side: Rc 1/4, 3/8, C8, C10 Bottom: Rc 1/4, 3/8 (Option)	Side: Rc 1/2 EXH port: Rc 1
<b>Stations</b>	2 to 10 stations (With multi-connector/D-sub connector: 2 to 8 stations)		
<b>Applicable exhaust cleaners</b>	AMC610-10 (Port size: R1) <small>Note</small>		

Note) Exhaust cleaner "AMC610-10" is not included.

Note) Electrical entry and light/surge voltage suppressor: D/DZ/DO/DOZ, Y/YZ/YO/YOZ, F, FZ only



### How to Order

**VV5FR3 - 10 - 06 1 - 03 - CD -**

VFR3000 Series Manifold

**Base type / Electrical entry**

01T	Plug-in type with terminal block
01C	Plug-in type with multi-connector
01F	Plug-in type with D-sub connector
10	Non plug-in type Common electrical entry
40	Non plug-in type Individual electrical entry

**Connector mounting direction**

Symbol	With connector	Applicable base
Nil	None	01T, 10, 40
D	D side mounting	01C, 01F
U	U side mounting	

**Thread type**

Nil	Rc
F	G
T	NPTF

**Exhaust cleaner mounting direction**

Symbol	Exhaust cleaner mounting direction
CD	D side   D side mounting
CU	U side   U side mounting

**Port size**

Symbol	P, EA, EB	A, B *
02		1/4
03		3/8
C8	1/2	One-touch fitting for ø8
C10		One-touch fitting for ø10
M		Mixed

\* For bottom ported: Rc 1/4, 3/8  
\* For C8 and C10, the thread type is only Rc.

**Stations**

02	2 stations
10 (Note)	10 stations

Note) • Base 01T/10/40: 2 to 10 stations  
• Base 01C/01F: 2 to 8 stations

**Symbol**

Symbol	Passage		Porting specifications (A, B)
	P	EA, EB	
1	Common	Common	Side
2			Bottom *

\* Semi-standard

- SV
- SYJ
- SZ
- VF
- VP4
- VQ 1/2
- VQ 4/5
- VQC 1/2
- VQC 4/5
- VQZ
- SQ
- VFS
- VFR
- VQ7

### How to Order Manifold Assembly

<Example> Plug-in type with terminal block (6 stations)

VV5FR3-01T-061-03-CD (-Q) .....	1 set (Manifold base part no.)
*VFR3100-5FZ (-Q) .....	3 sets (2 position single part no.)
*VFR3200-5FZ (-Q) .....	2 sets (2 position double part no.)
*VVFS3000-10A .....	1 set (Blanking plate assembly part no.)
*AMC610-10 .....	1 set (Exhaust cleaner part no.)

↳ The asterisk denotes the symbol for assembly. Prefix it to the part nos. of the solenoid valve, etc.

Valve arrangement is counted from the D side.  
When ordering, specify the part nos. in order from the 1st. station in the D side.  
When entry of part numbers becomes complicated, indicate on the manifold specification sheet.

### Caution

When using an exhaust cleaner, mount it downwards.

<Example> Non plug-in type: 6 stations

VV5FR3-10-061-03-CU (-Q) .....	1 set (Manifold base part no.)
*VFR3110-5E (-Q) .....	3 sets (2 position single part no.)
*VFR3210-5E (-Q) .....	2 sets (2 position double part no.)
*VVFS3000-10A .....	1 set (Blanking plate assembly part no.)
*AMC610-10 .....	1 set (Exhaust cleaner part no.)

↳ The asterisk denotes the symbol for assembly. Prefix it to the part nos. of the solenoid valve, etc.

Valve arrangement is counted from the D side.  
When ordering, specify the part nos. in order from the 1st. station in the D side.  
When entry of part numbers becomes complicated, indicate on the manifold specification sheet.

Refer to Best Pneumatics No. 7 for Exhaust Cleaner details.





# VFR3000 Series

## Manifold with Exhaust Cleaner: Plug-in Type/Non Plug-in Type

### Plug-in type: VV5FR3-01T-Station 1-Port size- $\frac{CD}{CU}$

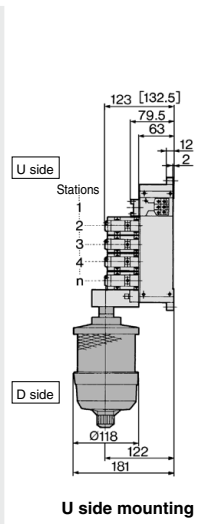
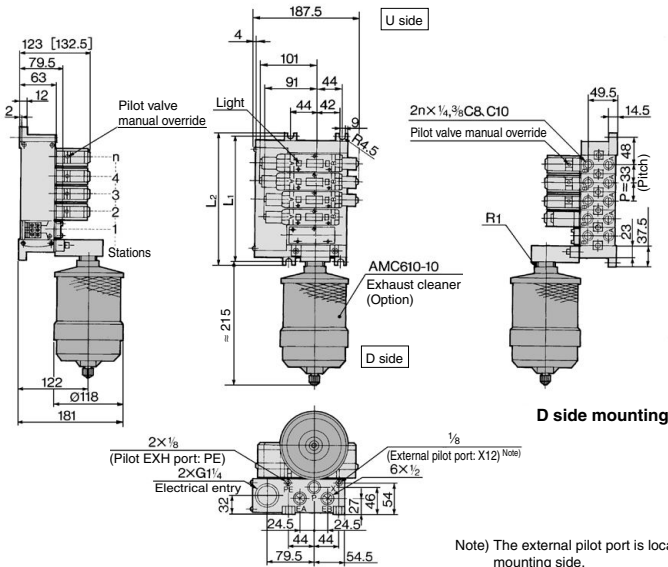

Note) The external pilot port is located on a side opposite to the exhaust cleaner mounting side.  
 D side mounting: External pilot port U side  
 U side mounting: External pilot port D side

[ ]: With direct manual override

### Non plug-in type: VV5FR3-10-Station 1-Port size- $\frac{CD}{CU}$

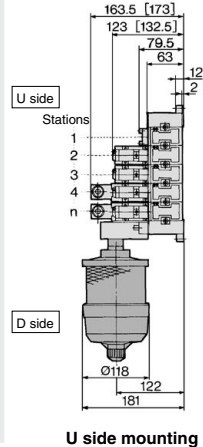
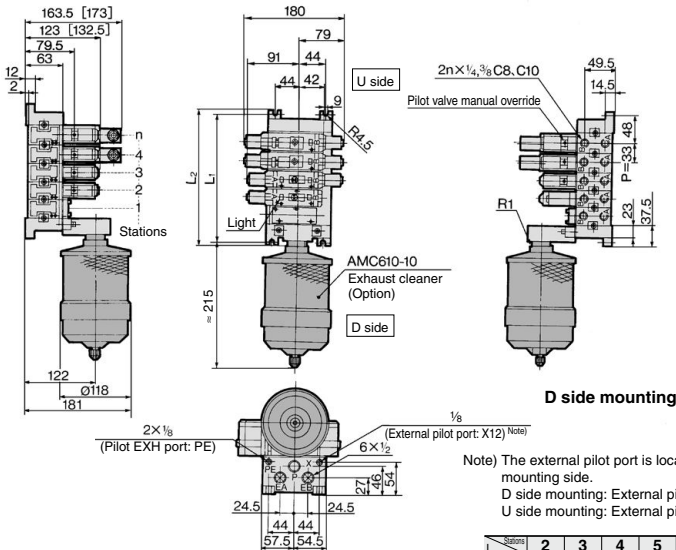

Note) The external pilot port is located on a side opposite to the exhaust cleaner mounting side.  
 D side mounting: External pilot port U side  
 U side mounting: External pilot port D side

[ ]: With direct manual override

1054



Stations	2	3	4	5	6	7	8	9	10	Formula
L <sub>1</sub>	129	162	195	228	261	294	327	360	393	L <sub>1</sub> = 33 x n + 63
L <sub>2</sub>	141	174	207	240	273	306	339	372	405	L <sub>2</sub> = 33 x n + 75

n: Station



5 Port Pilot Operated Solenoid Valve  
Rubber Seal, Plug-in/Non Plug-in **VFR3000 Series**

**Manifold with Exhaust Cleaner: Non Plug-in Type**

Non plug-in type: VV5FR3-40-Station 1-Port size -  $\text{C}\text{D}$

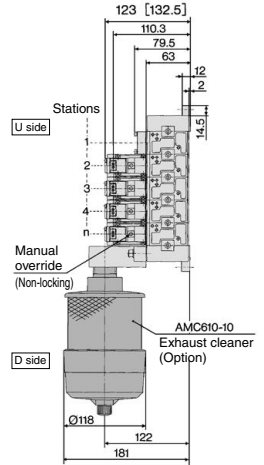
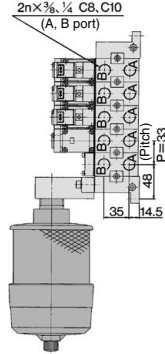
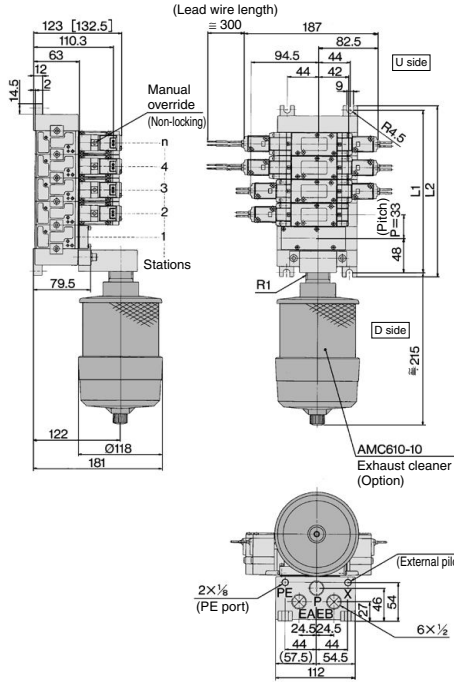

Note) The external pilot port is located on a side opposite to the exhaust cleaner mounting side.  
D side mounting: External pilot port U side  
U side mounting: External pilot port D side

[ ]: With direct manual override

SV
SYJ
SZ
VF
VP4
VQ 1/2
VQ 4/5
VQC 1/2
VQC 4/5
VQZ
SQ
VFS
VFR
VQ7

		n: Station									
Ports		2	3	4	5	6	7	8	9	10	Formula
L <sub>1</sub>		129	162	195	228	261	294	327	360	393	L <sub>1</sub> = 33 x n + 63
L <sub>2</sub>		141	174	207	240	273	306	339	372	405	L <sub>2</sub> = 33 x n + 75

# VFR3000 Series

## Manifold with Control Unit

- Control unit (Filter, Regulator, Pressure switch, Air release valve) are all standardized to the one unit, and can be mounted on the manifold base without any attachments.
- Piping processes are eliminated.

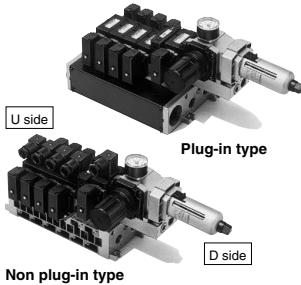

Non plug-in type

### Caution

Air filter with auto-drain or manual drain must be mounted with the air filter at the bottom.

### Manifold Specifications

Manifold	Plug-in type: VV5FR3-01□(-Q)	Non plug-in type: VV5FR3-10(-Q)	Non plug-in type: VV5FR3-40(-Q)
Wiring	With terminal block With multi-connector With D-sub connector	DIN terminal Grommet terminal	Grommet, Grommet terminal Conduit terminal, DIN terminal
Applicable valve model	VFR3□0□□-□F(-Q)	VFR3□1□□□□(-Q) VFR3□1□□□E	VFR3□4□□□□G, VFR3□4□□□□E VFR3□4□□□□□T, VFR3□4□□□□□Y(-Q)
Porting specifications	Common SUP, Common EXH		
	A, B port P, EA, EB port	Side: Rc 1/4, 3/8, C8, C10 Bottom: Rc 1/4, 3/8 (Option) Side: Rc 1/2	
Stations	2 to 10 (With multi-connector/D-sub connector: 2 to 8) *		

\* Including station of control unit

### Control Unit Specifications

Air filter (With auto-drain/With manual drain)	
Filteration degree	5 μm
Regulator	
Set pressure (Outlet pressure)	0.05 to 0.85 MPa
Pressure switch	
Set pressure range: OFF	0.1 to 0.6 MPa
Differential	0.08 MPa
Contact	1a
Indicator light	LED (RED)
Max. switch capacity	2 VA AC, 2 W DC
Max. operating current	24 VDC or less: 50 mA 100 VAC: 20 mA
Inside voltage drop	4 V or less
Air release valve (Single only)	
Operating pressure range	0.2 to 0.9 MPa

### Control Unit/Option

Air release valve spacer	<Plug-in type> VVFS3000-24A-1R (D side mounting)	
	<Non plug-in type> VVFS3000-24A-2R (D side mounting)	
Pressure switch	IS1000P-2-1	
Blanking plate	For filter regulator	MP2-3
	For pressure switch	MP3-2
	For air release valve	VVFS3000-24A-10
Filter element	INA-13-854-12-5B	

Note 1) Combining valve "VFR31□□" (single) and release valve spacer makes it possible to use this as an air release valve.

Note 2) Pressure switch cannot be mounted later on non plug-in type.

# 5 Port Pilot Operated Solenoid Valve Rubber Seal, Plug-in/Non Plug-in **VFR3000 Series**

Note) Electrical entry and light/surge voltage suppressor: D/DZ/DO/DOZ, Y/YZ/YO/YOZ, F, FZ only.



## How to Order

**VV5FR3 - 10 - 08 1 - 02 - AP -**

**VFR3000 Series Manifold**

**Base type/Electrical entry**

01T	Plug-in with terminal block
01C	Plug-in with multi-connector
01F	Plug-in type with D-sub connector
10	Non plug-in type (Common entry)
40	Non plug-in type (Individual entry)

**Connector mounting direction**

Symbol	With connector	Applicable base
Nil	None	01T, 10, 40
D	D side mounting	01C, 01F
U	U side mounting	

**Stations**

02	2 stations
10 <sup>(min)</sup>	10 stations

Note) • Base 01T/10/40: 2 to 10 stations  
• Base 01C/01F: 2 to 8 stations  
• Including stations of control unit.

**Symbol**

Symbol	Passage		Porting specifications (A, B)
	P	EA, EB	
1	Common	Common	Side
2			Bottom *

\* Semi-standard

**Port size**

Symbol	P, EA, EB	A, B
02		1/4
03		3/8
C8	1/2	One-touch fitting for ø8
C10		One-touch fitting for ø10
M		Mixed

\* For bottom ported: only 1/4, 3/8  
\* For C8 and C10, the thread type is only Rc.

**Thread type**

Nil	Rc
F	G
T	NPTF

**CE-compliant**

Nil	—
Q	CE-compliant

Note) Electrical entry and light/surge voltage suppressor: D/DZ/DO/DOZ, Y/YZ/YO/YOZ, F, FZ only.

**Control unit type**

Nil	None
1	100 VAC, 50/60 Hz
5	24 VDC

Note 1) Adjust the voltage to the coil rated voltage of the mounted valve.  
Note 2) For other rated voltages, please consult with SMC.

**Control unit type**

Control equipment	Symbol									
	Nil	MP	AP	M	A	G	F	C	E	
Air release valve		●	●	●	●			●	●	
Air filter regulator with manual drain		●		●	●					
Air filter regulator with auto-drain			●		●			●		
Pressure switch		●	●							
Blanking plate (Air release valve)						●	●			
Blanking plate (Filter regulator)								●	●	
Blanking plate (Pressure switch)				●	●	●	●	●	●	
Required stations										1 station

Note) Control unit is D side mounting only.

- SV
- SYJ
- SZ
- VF
- VP4
- VQ 1/2
- VQ 4/5
- VQC 1/2
- VQC 4/5
- VQZ
- SQ
- VFS
- VFR
- VQ7

## How to Order Manifold Assembly

<Example> Plug-in type with terminal block

VV5FR3-01T-081-03-AP5 (-Q) ..... 1 set (Manifold base part no.)  
 \*VFR3100-5FZ (-Q) ..... 4 sets (2 position single part no.)  
 \*VFR3200-5FZ (-Q) ..... 2 sets (2 position double part no.)

↳ The asterisk denotes the symbol for assembly. Prefix it to the part nos. of the solenoid valve, etc.

The 1st and 2nd station are used for control unit mounting.  
 When ordering, specify the part nos. in order from the 3rd. station in the D side.  
 When entry of part numbers becomes complicated, indicate on the manifold specification sheet.

<Example> Non plug-in type

VV5FR3-10-061-03-A5 (-Q) ..... 1 set (Manifold base part no.)  
 \*VFR3110-5D (-Q) ..... 4 sets (2 position single part no.)

↳ The asterisk denotes the symbol for assembly. Prefix it to the part nos. of the solenoid valve, etc.

The 1st and 2nd station are used for control unit mounting.  
 When ordering, specify the part nos. in order from the 3rd. station in the D side.  
 When entry of part numbers becomes complicated, indicate on the manifold specification sheet.



# VFR3000 Series

## Manifold with Control Unit: Plug-in Type/Non Plug-in Type

Plug-in type:

VV5FR3-01T-Station 1-Port size-AP Voltage of air release valve

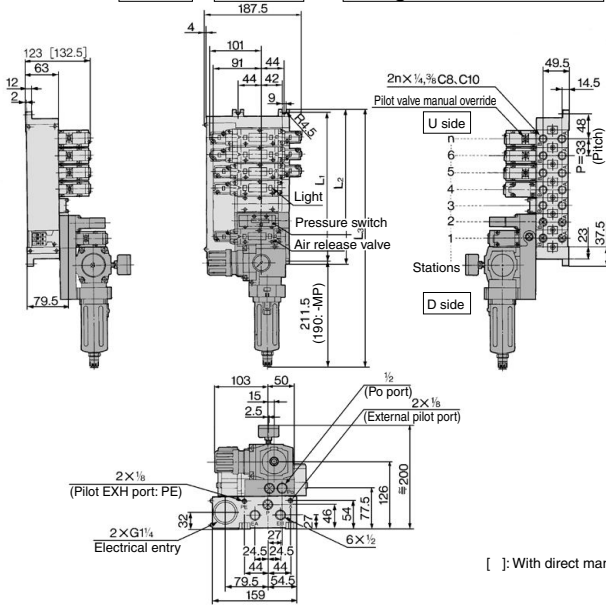

[ ]: With direct manual override

Example for manifold

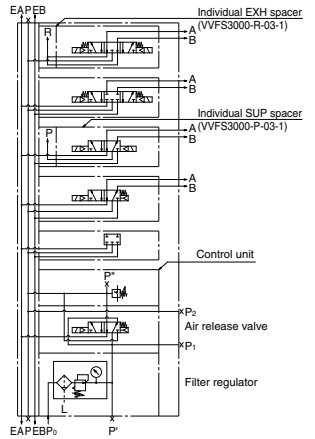

Non plug-in type:

VV5FR3-10-Station 1-Port size-AP Voltage of air release valve

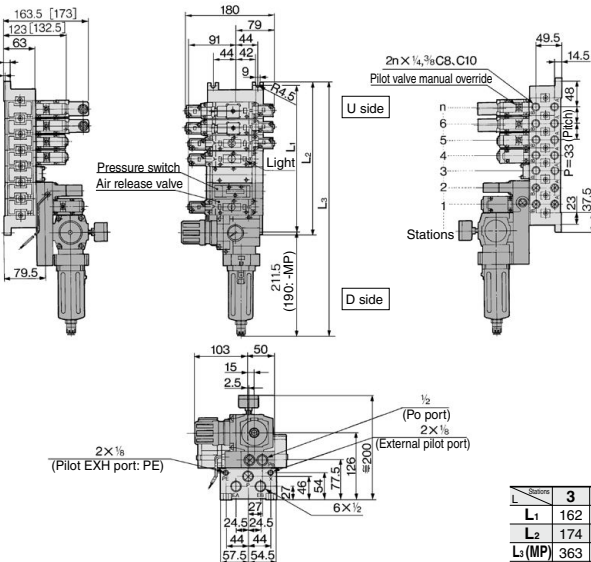

[ ]: With direct manual override

1058

Example for manifold

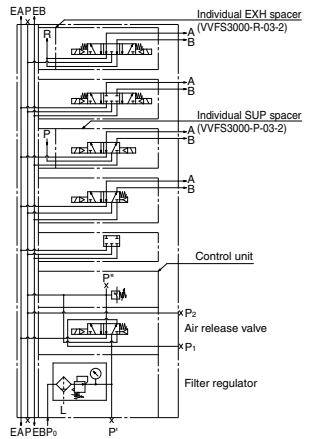

n: Station

Station	3	4	5	6	7	8	9	10	Formula
L <sub>1</sub>	162	195	228	261	294	327	360	393	L <sub>1</sub> = 33 x n + 63
L <sub>2</sub>	174	207	240	273	306	339	372	405	L <sub>2</sub> = 33 x n + 75
L <sub>3</sub> (MP)	363	396	429	462	495	528	561	594	L <sub>3</sub> = 33 x n + 264
L <sub>3</sub> (AP)	384.5	417.5	450.5	483.5	516.5	549.5	582.5	615.5	L <sub>3</sub> = 33 x n + 285.5



# 5 Port Pilot Operated Solenoid Valve Rubber Seal, Plug-in/Non Plug-in **VFR3000 Series**

## Manifold with Control Unit: Non Plug-in Type

Non plug-in type: **VV5FR3-40-Station 1-Port size-AP Voltage of air release valve**

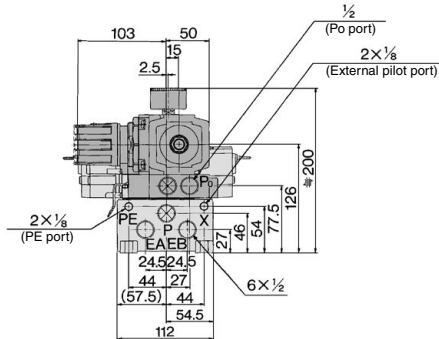
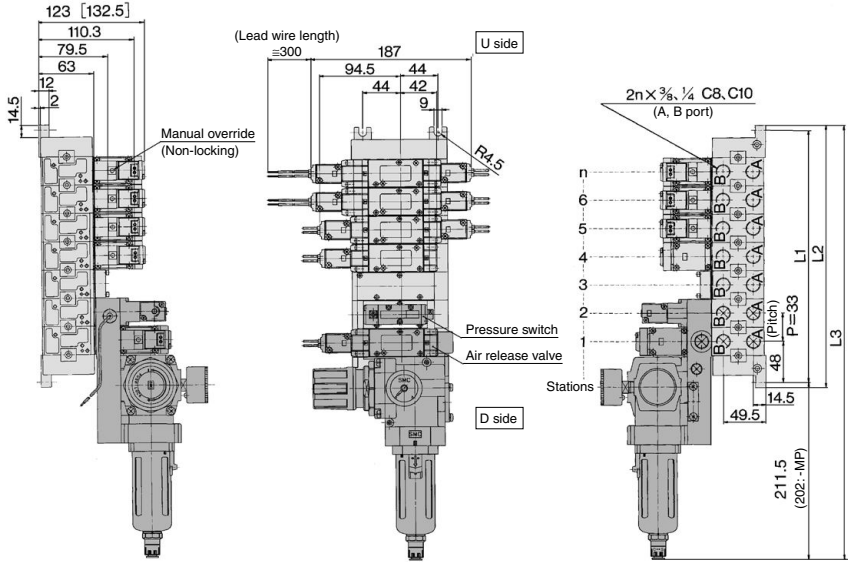

	n: Station									
Station	3	4	5	6	7	8	9	10	Formula	
L <sub>1</sub>	162	195	228	261	294	327	360	393	L <sub>1</sub> = 33 x n + 63	
L <sub>2</sub>	174	207	240	273	306	339	372	405	L <sub>2</sub> = 33 x n + 75	
L <sub>3</sub> (MP)	363	396	429	462	495	528	561	594	L <sub>3</sub> = 33 x n + 264	
L <sub>3</sub> (AP)	384.5	417.5	450.5	483.5	516.5	549.5	582.5	615.5	L <sub>3</sub> = 33 x n + 285.5	

( ): MP

[ ]: With direct manual override

- SV
- SYJ
- SZ
- VF
- VP4
- VQ 1/2
- VQ 4/5
- VQC 1/2
- VQC 4/5
- VQZ
- SQ
- VFS
- VFR
- VQ7

# VFR3000 Series

## Manifold Base Construction: Plug-in Type/Non Plug-in Type

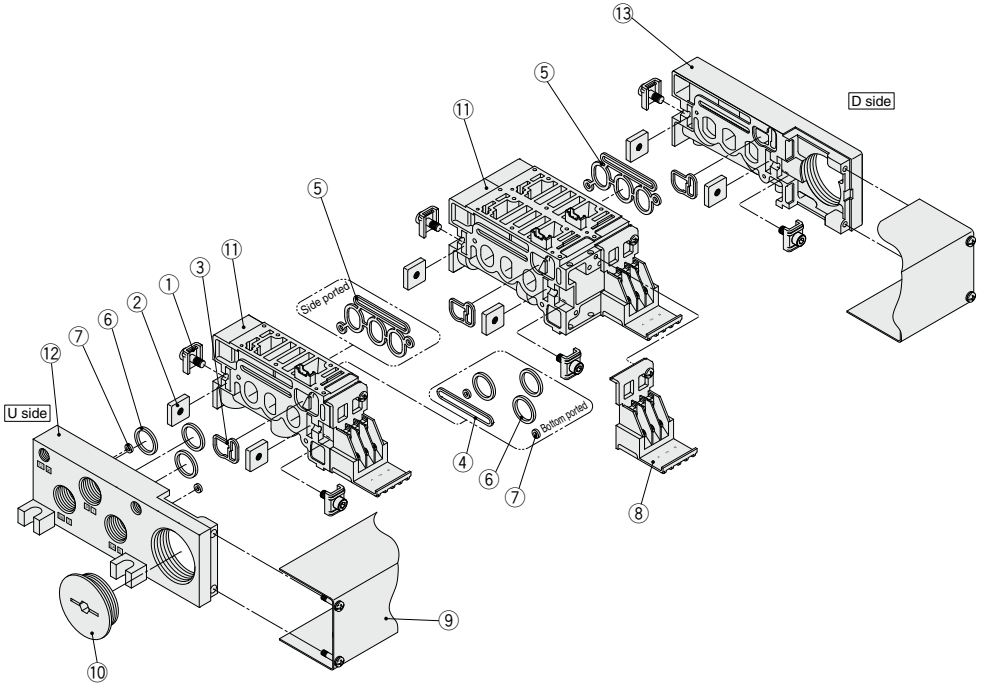

### Replacement Parts

No.	Description	Material	Part no.
1	Connection fitting A	Steel	VVFS3000-5-1A
2	Connection fitting B	Steel	VVFS3000-5-2
3	Gasket	NBR	VVFS3000-7-1
4	Gasket	NBR	VVFS3000-8
5	Gasket	NBR	VVFS3000-32-1
6	O-ring	NBR	KA00232H
7	O-ring	NBR	KA00020H
8	Terminal assembly	—	VVFS3000-6A
9	Junction cover assembly	—	For 01T VVFS3000-4A- <u>Stations</u>
10	Rubber plug	NBR	AXT336-9

Note) Manifold Base/Construction: Plug-in type with terminal block.

### Replacement Parts: Sub Assembly

No.	Description	Assembly part no.	Component parts	Applicable manifold base
11	Manifold block assembly <sup>Note)</sup>	VVFS3000-1A-1- <sup>02</sup> / <sub>010</sub>	Manifold block (10), Terminal (8), Connection bracket (1, 2), Gasket (3, 4), O-ring (6, 7), Receptacle assembly	Plug-in type
		VVFS3000-1A-2- <sup>02</sup> / <sub>010</sub>	Manifold block (9), Connection bracket (1, 2), Gasket (3, 4), O-ring (6, 7)	Non plug-in type
12	End plate (U side) assembly	VVFS3000-2A-1	End plate (U) (11), Connection bracket (1, 2), Gasket (4), O-ring (5, 7)	Plug-in type
		VVFS3000-2A-2	End plate (U) (11), Connection bracket (1, 2), Gasket (4), O-ring (5, 7)	Non plug-in type
13	End plate (D side) assembly	VVFS3000-3A-1	End plate (D) (12), Connection bracket (1, 2), Gasket (3)	Plug-in type
		VVFS3000-3A-2	End plate (D) (12), Connection bracket (1, 2), Gasket	Non plug-in type

Note) For side ported

\* Contact SMC for CE-compliant products.

# 5 Port Pilot Operated Solenoid Valve Rubber Seal, Plug-in/Non Plug-in VFR4000 Series



[Option] Note



NRTL / C

Note) Applicable only for DIN terminal and plug-in types.  
For details, refer to "How to Order".



Plug-in type



Non plug-in type

## Symbol

2 position	3 position
Single	Closed center
(A)4 2(B)  (EA)5 1 3(EB) (P)	(A)4 2(B)  (EA)5 1 3(EB) (P)
Double	Exhaust center
(A)4 2(B)  (EA)5 1 3(EB) (P)	(A)4 2(B)  (EA)5 1 3(EB) (P)
	Pressure center
	(A)4 2(B)  (EA)5 1 3(EB) (P)

## Standard Specifications

Valve specifications	Fluid		Air
	Operating pressure range	2 position single/3 position	0.2 to 0.9 MPa
		2 position double	0.1 to 0.9 MPa
	Ambient and fluid temperature		-10 to 50°C (No freezing.)
	Lubrication		Non-lube <sup>(1)</sup>
	Manual override		Non-locking push type
Mounting orientation		Unrestricted	
Impact/Vibration resistance		300/50 m/s <sup>2</sup> <sup>(2)</sup>	
Enclosure		Dustproof	
Electricity specifications	Coil rated voltage		100, 200 VAC (50/60 Hz), 24 VDC
	Allowable voltage fluctuation		-15 to -10% of rated voltage
	Apparent power (AC) <sup>(3)</sup>	Inrush	5.6 VA/50 Hz, 5.0 VA/60 Hz
		Holding	3.4 VA (2.1 W)/50 Hz, 2.3 VA (1.5 W)/60 Hz
	Power consumption (DC) <sup>(3)</sup>		1.8 W (2.04 W: With light/surge voltage suppressor)
	Electrical entry		Plug-in type: Conduit terminal Non plug-in type: Grommet, Grommet terminal, Conduit terminal, DIN terminal

Note 1) Use turbine oil Class 1 (ISO VG32), if lubricated.

Note 3) At rated voltage

Note 2) Impact resistance: No malfunction occurred when it is tested with a drop tester in the axial direction and at the right angles to the main valve and armature in both energized and de-energized states every once for each condition. (Values at the initial period)

Vibration resistance: No malfunction occurred in a one-sweep test between 45 and 2000 Hz. Test was performed at both energized and de-energized states in the axial direction and at the right angles to the main valve and armature. (Values at the initial period)

## Option Specifications

Pilot type		External pilot <sup>Note)</sup>
Manual override	Main valve	Direct manual override
	Pilot valve	Non-locking push type A (Extended), Locking type B (Tool required), Locking type C (Lever)
Coil rated voltage		110 to 120, 220, 240 VAC 50/60 Hz 12 VDC
Porting specifications		Bottom ported
Option		With light/surge voltage suppressor

Note) Operating pressure: 2 position 0 to 0.9 MPa  
3 position 0.15 to 0.9 MPa

Pilot pressure: 2 position single 0.2 to 0.9 MPa  
2 position double 0.1 to 0.9 MPa  
3 position 0.5 x P - 0.1 to 0.9 MPa  
(P: Operating pressure)

## Model

Type of actuation	Model		Port size <sup>(1)</sup>	Flow rate characteristics <sup>(2)</sup>						Max. <sup>(3)</sup> operating cycle (Hz)	Response time (ms)	Weight (kg)	
	Plug-in	Non plug-in		1 → 4/2 (P → A/B)			4/2 → 5/3 (A/B → EA/EB)						
				C [dm <sup>3</sup> /(s·bar)]	b	Cv	C [dm <sup>3</sup> /(s·bar)]	b	Cv				
2 position	Single	VFR410□	VFR411□	3/8	13	0.30	3.2	14	0.28	3.4	5	50 or less	1.10 (1.04) <1.04>
		VFR410□	VFR414□	1/2	15	0.30	3.8	14	0.30	3.8			
	Double	VFR420□	VFR421□	3/8	14	0.31	3.4	14	0.26	3.4	5	50 or less	1.20 (1.16) <1.16>
		VFR420□	VFR424□	1/2	15	0.30	4.0	14	0.30	3.7			
3 position	Closed center	VFR430□	VFR431□	3/8	13	0.32	3.2	13	0.25	3.0	3	70 or less	1.20 (1.16) <1.16>
		VFR430□	VFR434□	1/2	14	0.28	3.5	13	0.29	3.4			
	Exhaust center	VFR440□	VFR441□	3/8	13	0.31	3.2	14 [13]	0.32 [0.30]	3.6 [3.2]	3	70 or less	1.20 (1.19) <1.16>
		VFR440□	VFR444□	1/2	14	0.30	3.7	14 [13]	0.32 [0.30]	3.6 [3.2]			
	Pressure center	VFR450□	VFR451□	3/8	13 [5.0]	0.27 [0.42]	3.2 [1.3]	13	0.28	3.1	3	70 or less	1.20 (1.16) <1.16>
		VFR450□	VFR454□	1/2	15 [5.3]	0.22 [0.42]	3.7 [1.5]	13	0.28	3.3			

Note 1) EA, EB port: Rc 3/8

Note 2) [ ]: Normal position

Note 3) Min. operating frequency is once in 30 days.

Note 4) Based on dynamic performance test, JIS B 8419: 2010. (0.5 MPa, Coil temperature: 20°C, at rated voltage, without surge voltage suppressor)

Note 5) For VFR4□00-□FZ-□□, ( ): VFR4□10- DZ□-□□, < >: VFR4□40-□G-□□



# VFR4000 Series



## How to Order

Note) Electrical entry and light/surge voltage suppressor: D/DZ/DO/DOZ, Y/YZ/YO/YOZ, F, FZ only

**Electrical entry**

F: Plug-in type, conduit type

CE-compliant

**Option**

<b>N</b>	None
<b>Z</b>	With light/surge voltage suppressor

**Porting specifications (P, A, B, EA, EB port)**

<b>N</b>	Side ported
<b>B</b>	Bottom ported

\* Option, no bottom piping for external pilot.

**Port size (P, A and B port)**

<b>N</b>	Without sub-plate
<b>03</b>	3/8
<b>04</b>	1/2

\* EA, EB port: Rc 3/8

**Thread type**

<b>N</b>	Rc
<b>F</b>	G
<b>N</b>	NPT
<b>T</b>	NPTF

**CE-compliant**

<b>N</b>	—
<b>Q</b>	CE-compliant (Note)

Note) Electrical entry and light/surge voltage suppressor: D/DZ/DO/DOZ, Y/YZ/YO/YOZ, F, FZ only.

**Plug-in** VFR4  0   - 5  F    -  03   -

**Non plug-in** VFR4  1   - 1  D    -  03   -

**Non plug-in** VFR4  4   - 1  G    -  03   -

**Body option**

<b>0</b>	Standard
<b>1</b>	Direct manual override

\* Semi-standard

**Pilot type**

<b>N</b>	Internal pilot
<b>R</b>	External pilot

**Coil rated voltage**

<b>1</b>	100 VAC, 50/60 Hz
<b>2</b>	200 VAC, 50/60 Hz
<b>3</b>	110 V to 120 VAC, 50/60 Hz
<b>4</b>	220 VAC, 50/60 Hz
<b>5</b>	24 VDC
<b>6</b>	12 VDC
<b>7</b>	240 VAC, 50/60 Hz

For other rated voltages, please consult with SMC.

**Option: VFR4□1□**

<b>N</b>	None
<b>Z</b>	With light/surge voltage suppressor

**Option: VFR4□4□**

<b>N</b>	None
<b>Z</b>	With light/surge voltage suppressor
<b>S</b>	With surge voltage suppressor

\* Indicator light (Z) is not available for grommet type. Surge voltage suppressor (S) is available only on grommet.

**Electrical entry: VFR4□1□**

<b>E</b>	Grommet terminal
<b>D</b>	DIN terminal
<b>DO</b>	DIN terminal without connector

CE-compliant

**Electrical entry: VFR4□4□**

<b>G</b>	Grommet
<b>E</b>	Grommet terminal
<b>T</b>	Conduit terminal
<b>D, Y</b>	DIN terminal
<b>DO, YO</b>	DIN terminal without connector

CE-compliant

**Common electrical entry**

**Individual electrical entry**

**Pilot valve Manual override**

**N**: Non-locking push type

**A**: Non-locking push type A (Extended)

**B**: Locking type B (Tool required)

**C**: Locking type C (Lever)

\* Semi-standard

## How to Order Pilot Valve Assembly

SF4 - 1 F - 70 - - -

**Coil rated voltage**

Symbol	Rated voltage
<b>1</b>	100 VAC, 50/60 Hz
<b>2</b>	200 VAC, 50/60 Hz
<b>3</b>	110 to 120 VAC, 50/60 Hz
<b>4</b>	220 VAC, 50/60 Hz
<b>5</b>	24 VDC
<b>6</b>	12 VDC
<b>7</b>	240 VAC, 50/60 Hz

For other rated voltages, please consult with SMC.

**Electrical entry, Light/Surge voltage suppressor**

Symbol	Electrical entry	Indicator light	With surge voltage suppressor	Applicable valve model	CE-compliant
<b>F</b>	Plug-in	—	—	VFR4□□□ VFR4□1□	●
<b>G</b>	Grommet	—	—	—	—
<b>GS</b>	Grommet	—	●	—	—
<b>E</b>	Grommet terminal	●	●	—	—
<b>EZ</b>	Grommet terminal	—	—	—	—
<b>T</b>	Conduit terminal	●	●	—	—
<b>TZ</b>	Conduit terminal	—	—	—	—
<b>D</b>	DIN terminal	●	●	VFR4□4□	●
<b>DZ</b>	DIN terminal	—	—	—	—
<b>DO</b>	DIN terminal	●	●	—	●
<b>DOZ</b>	DIN terminal	—	—	—	—
<b>Y</b>	DIN terminal	●	●	—	●
<b>YZ</b>	DIN terminal	—	—	—	—
<b>YOZ</b>	DIN terminal (DIN43650B type)	●	●	—	●

**Manual override**

<b>N</b>	Non-locking push type
<b>A</b>	Non-locking push type A (Extended)
<b>B</b>	Locking type B (Tool required)
<b>C</b>	Locking type C (Lever)

**Symbol**

Symbol	Applicable valve model
<b>N</b>	VFR4□0□ VFR4□1□
<b>1</b>	VFR4□4□

\* VFR4□0□, VFR4□1□: Pilot valve assembly is all plug-in (F).

**CE-compliant**

<b>N</b>	—
<b>Q</b>	CE-compliant (Note)

Note) Electrical entry and light/surge voltage suppressor: D/DZ/DO/DOZ, Y/YZ/YO/YOZ, F only.





# 5 Port Pilot Operated Solenoid Valve **VFR4000 Series** Rubber Seal, Plug-in/Non Plug-in

Use as a guide for selection.  
Please confirm the actual conditions with SMC  
Sizing Program.

## Cylinder Speed Chart

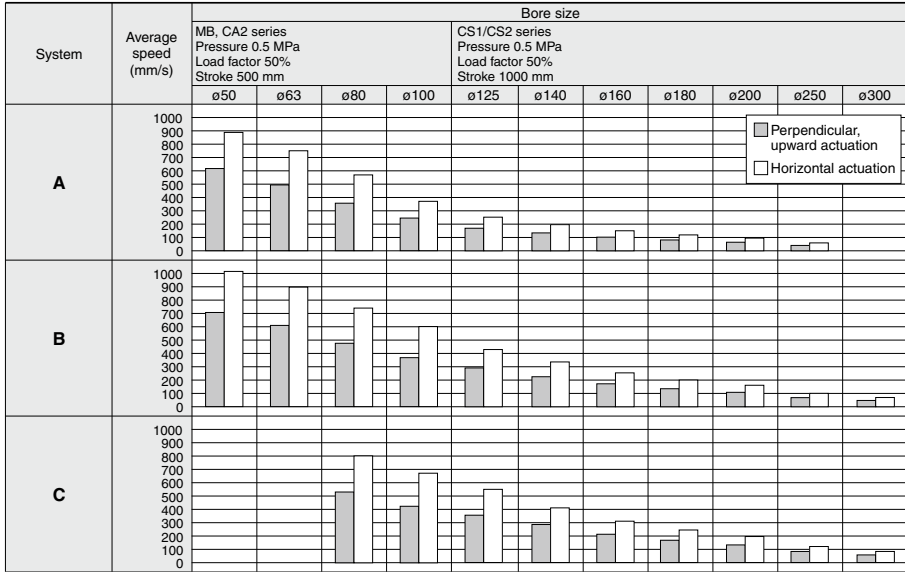

- \* It is when the cylinder is extending that is meter-out controlled by speed controller which is directly connected with cylinder, and its needle valve with being fully open.
- \* The average velocity of the cylinder is what the stroke is divided by the total stroke time.
- \* Load factor: ((Load mass x 9.8)/Theoretical force) x 100%

## System Components

System	Solenoid valve	Speed controller	Silencer	SPG (Steel pipe) dia. x Length
A	VFR4000 Series Rc 3/8	AS4000-03	AN30-03	10A x 1 m
B	VFR4000 Series Rc 3/8	AS420-03	AN30-03	10A x 1 m
C	VFR4000 Series Rc 1/2	AS420-04	AN40-04	15A x 1 m

## How to Order Sub-plate Assembly

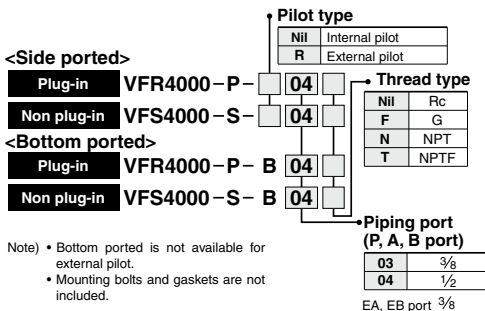

- Note) • Bottom ported is not available for external pilot.  
• Mounting bolts and gaskets are not included.

- SV
- SYJ
- SZ
- VF
- VP4
- VQ 1/2
- VQ 4/5
- VQC 1/2
- VQC 4/5
- VQZ
- SQ
- VFS
- VFR
- VQ7

# VFR4000 Series

## Construction

### 2 position single

VFR41□□

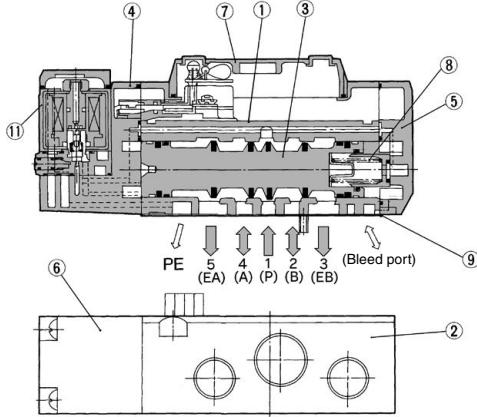
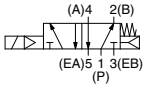

### 2 position double

VFR42□□

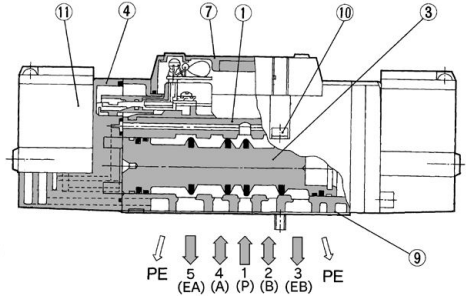
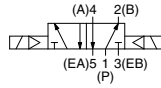

### 3 position closed center/exhaust center/pressure center

Closed center: VFR43□□

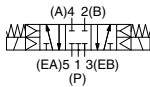

Exhaust center: VFR44□□



Pressure center: VFR45□□

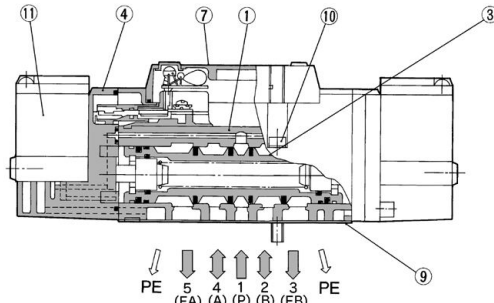
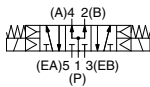

This figure shows a closed center type.

## Component Parts

No.	Description	Material	Note
1	Body	Aluminum die-casted	Platinum silver
2	Sub-plate	Aluminum die-casted	Platinum silver
3	Spool valve	Aluminum, NBR	
4	Adapter plate	Resin	Black

## Component Parts

No.	Description	Material	Note
5	End plate	Resin	Black
6	Junction cover	Resin	
7	Light cover	Resin	
8	Spool spring	Stainless steel	

## Replacement Parts

No.	Description	Material	Part no.		
			VFR41□□	VFR42□□	VFR43□□/44□□/45□□
9	Gasket	NBR	VFR4000-32-3	VFR4000-32-3	VFR4000-32-3
10	Hexagon socket head screw <small>Note)</small>	Steel	AXT335-1-11#1 (M4 x 40)	AXT335-1-11#1 (M4 x 40)	AXT335-1-11#1 (M4 x 40)
11	Pilot valve assembly	—	Refer to "How to Order Pilot Valve Assembly" on page 1062.		
—	Sub-plate assembly	—	Refer to "How to Order Sub-plate Assembly" on page 1063.		

Note) For the VFR4000 series, it requires 4 pcs.

5 Port Pilot Operated Solenoid Valve  
 Rubber Seal, Plug-in/Non Plug-in **VFR4000 Series**

**Plug-in: 2 Position Single/Double, 3 Position Closed Center/Exhaust Center/Pressure Center**

2 position single: VFR410<sup>0</sup>-□F

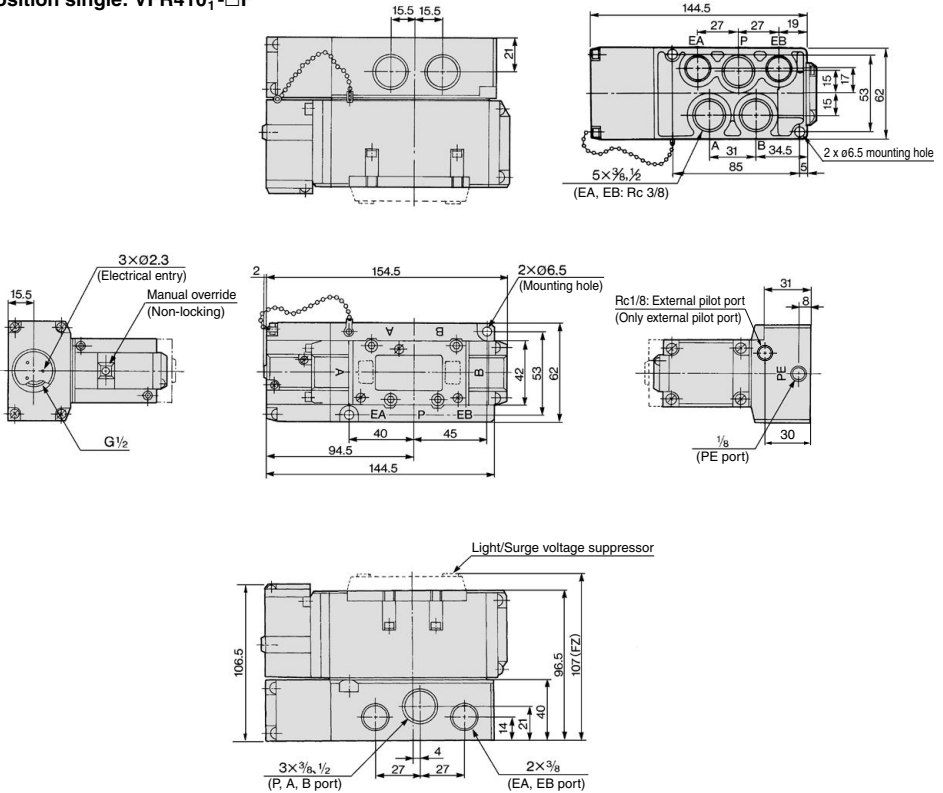

2 position double: VFR420<sup>0</sup>-□F

3 position closed center: VFR430<sup>0</sup>-□F

3 position exhaust center: VFR440<sup>0</sup>-□F

3 position pressure center: VFR450<sup>0</sup>-□F

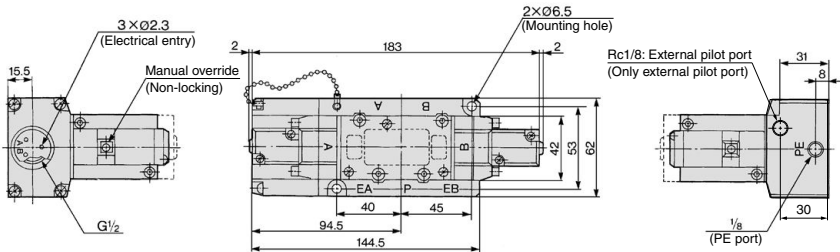

SV
SYJ
SZ
VF
VP4
VQ 1/2
VQ 4/5
VQC 1/2
VQC 4/5
VQZ
SQ
VFS
VFR
VQ7

# VFR4000 Series

## Non Plug-in: 2 Position Single/Double, 3 Position Closed Center/Exhaust Center/Pressure Center

2 position single: VFR411<sup>□</sup>-□E, VFR411<sup>□</sup>-□D

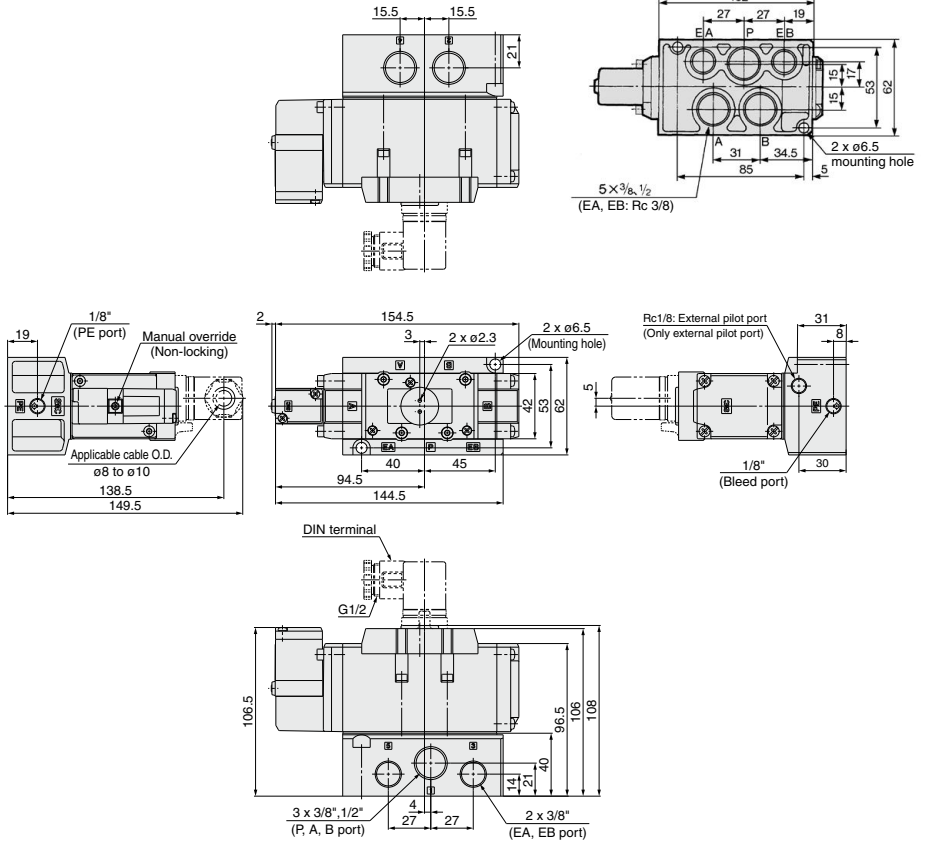

2 position double: VFR421<sup>□</sup>-□E, VFR421<sup>□</sup>-□D

3 position closed center: VFR431<sup>□</sup>-□E, VFR431<sup>□</sup>-□D  
 3 position exhaust center: VFR441<sup>□</sup>-□E, VFR441<sup>□</sup>-□D  
 3 position pressure center: VFR451<sup>□</sup>-□E, VFR451<sup>□</sup>-□D

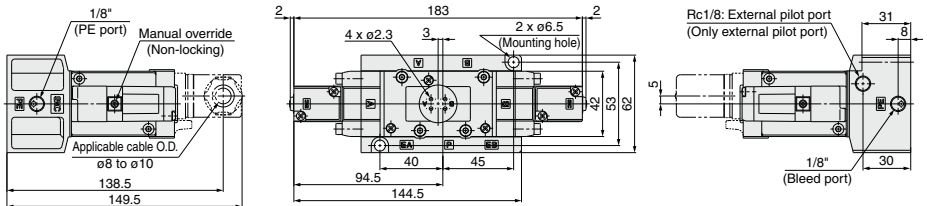

# 5 Port Pilot Operated Solenoid Valve Rubber Seal, Plug-in/Non Plug-in **VFR4000 Series**

## Non Plug-in: 2 Position Single

2 position single: VFR414□-□G

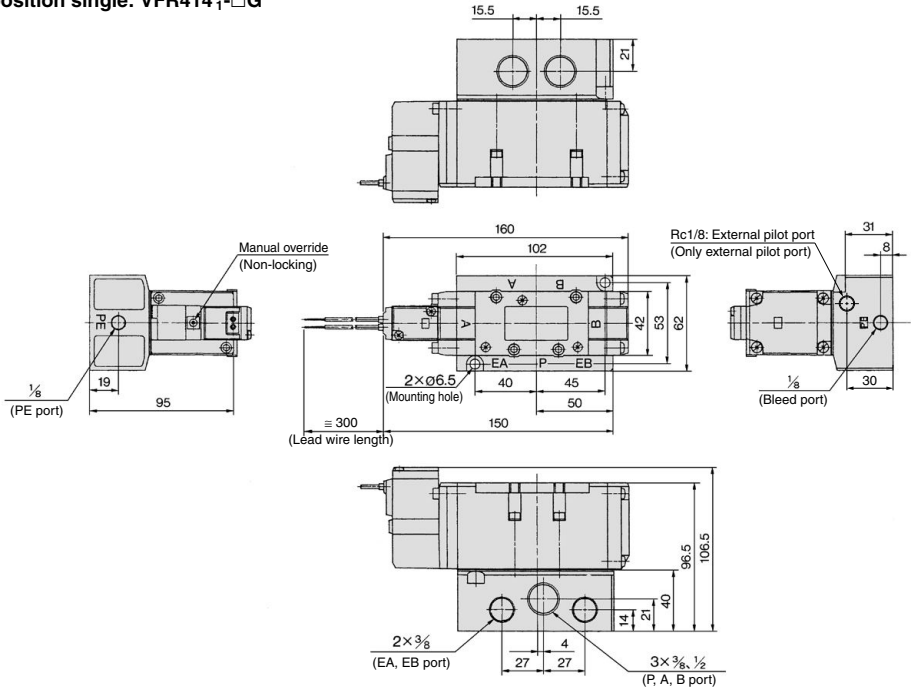

SV
SYJ
SZ
VF
VP4
VQ 1/2
VQ 4/5
VQC 1/2
VQC 4/5
VQZ
SQ
VFS
VFR
VQ7

### E: Grommet terminal

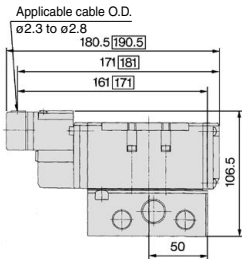

With light/surge voltage suppressor

### T: Conduit terminal

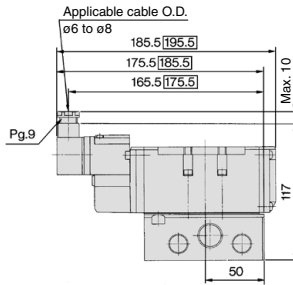

With light/surge voltage suppressor

### D, Y: DIN terminal

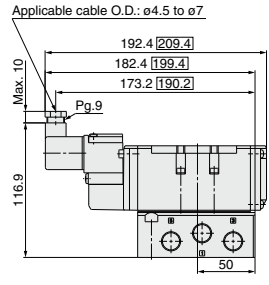

With light/surge voltage suppressor

# VFR4000 Series

## Non Plug-in: 2 Position Double, 3 Position Closed Center/Exhaust Center/Pressure Center

2 position double: VFR424<sup>0</sup>-□G

3 position closed center: VFR434<sup>0</sup>-□G

3 position exhaust center: VFR444<sup>0</sup>-□G

3 position pressure center: VFR454<sup>0</sup>-□G

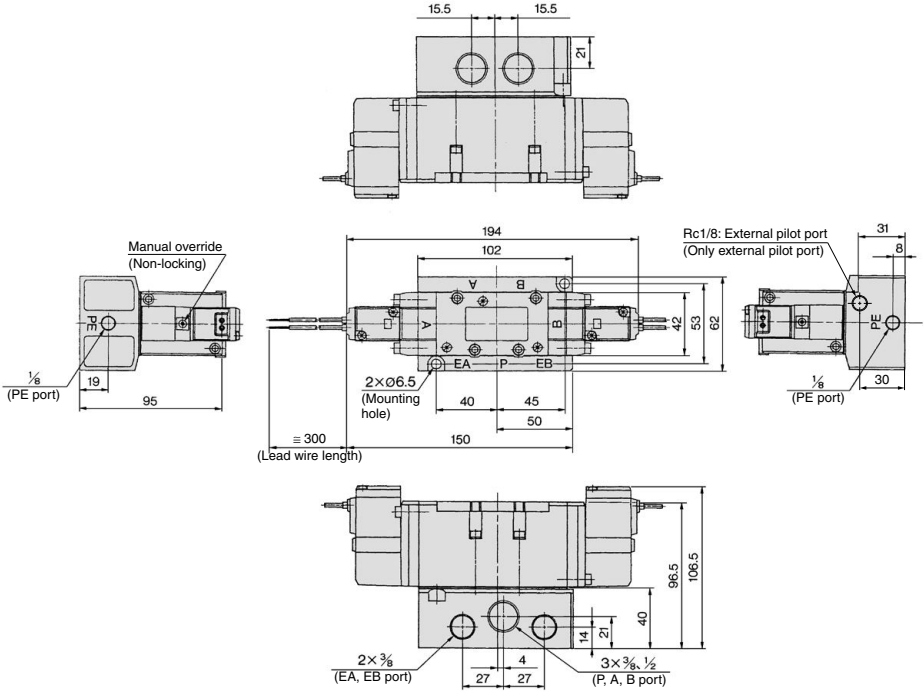

### E: Grommet terminal

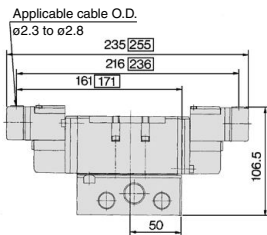

With light/surge voltage suppressor

### T: Conduit terminal

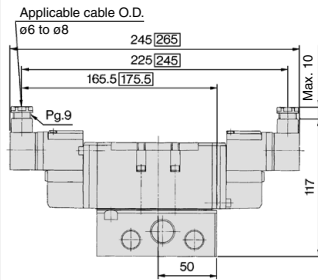

With light/surge voltage suppressor

### D: DIN terminal

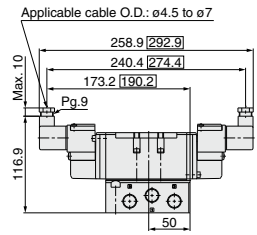

With light/surge voltage suppressor

# VFR4000 Series Manifold Specifications

## Manifold Specifications

Base model	Wiring	Porting specifications		Port size		Stations	Applicable valve model
		A, B port	P, EA, EB	A, B			
Plug-in type <b>VV5FR4-01□(-Q)</b>	<ul style="list-style-type: none"> <li>• With terminal block</li> <li>• With multi-connector</li> <li>• With D-sub connector</li> </ul>	Side/Bottom	1/2	3/8, 1/2	2 to 10	VFR4□0□-□F(-Q)	
Non plug-in type <b>VV5FR4-10(-Q)</b>	<ul style="list-style-type: none"> <li>• Grommet terminal</li> <li>• DIN terminal</li> </ul>				2 to 8		VFR4□1□-□E VFR4□1□-□D(-Q)
Non plug-in type <b>VV5FR4-40(-Q)</b>	<ul style="list-style-type: none"> <li>• Grommet</li> <li>• Grommet terminal</li> <li>• Conduit terminal</li> <li>• DIN terminal</li> </ul>				2 to 10		VFR4□4□-□G VFR4□4□-□E VFR4□4□-□T VFR4□4□-□D(-Q)

## How to Order Manifold Assembly

<Example> Plug-in type with terminal block: 6 stations

**VV5FR4-01T-061-03 (-Q)** ..... 1 set (Manifold base part no.)  
**\*VFR4100-5FZ (-Q)** ..... 3 sets (2 position single part no.)  
**\*VFR4200-5FZ (-Q)** ..... 2 sets (2 position double part no.)  
**\*VVFS4000-10A** ..... 1 set (Blanking plate assembly part no.)

↳ The asterisk denotes the symbol for assembly. Prefix it to the part nos. of the solenoid valve, etc.

Valve arrangement is counted from the D side.

When ordering, specify the part nos. in order from the 1st. station in the D side.

When entry of part numbers becomes complicated, indicate on the manifold specification sheet.

<Example> Non plug-in type: 6 stations

**VV5FR4-10-061-03 (-Q)** ..... 1 set (Manifold base part no.)  
**\*VFR4110-5D (-Q)** ..... 5 sets (2 position single part no.)  
**\*VFR4410-5D (-Q)** ..... 1 set (3 position exhaust center part no.)  
**\*VVFS4000-R-04-2** ..... 1 set (Individual EXH spacer part no.)

↳ The asterisk denotes the symbol for assembly. Prefix it to the part nos. of the solenoid valve, etc.

Valve arrangement is counted from the D side.

When ordering, specify the part nos. in order from the 1st. station in the D side.

When entry of part numbers becomes complicated, indicate on the manifold specification sheet.



[Option]

## Plug-in Type: With Terminal Block

- Since lead wires of solenoid valve are connected with the terminals on upper surface of terminal block corresponding lead wires from power source can be wired at the bottom of terminal block.

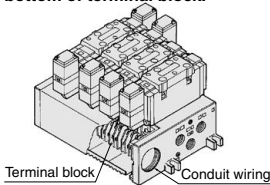

**VV5FR4-01T-061-03**

VFR4000 Series Manifold  
Plug-in type with terminal block

**Stations**

02	2 stations
:	:
10	10 stations

**Symbol**

Symbol	Passage		Porting specifications (A, B)
	P	EA, EB	
1	Common	Common	Side
2	Common	Common	Bottom *

\* Semi-standard

**Thread type**

Nil	Rc
F	G
N	NPT
T	NPTF

**Port size**

Symbol	P, EA, EB	A, B *
03	1/2	3/8
04	1/2	1/2
M		Mixed

\* For bottom ported: Rc 3/8 only.

**CE-compliant**

Nil	—
Q	CE-compliant

## Plug-in Type: With Multi-connector (For wiring specifications, refer to page 1113.)

- Master connection of power and solenoid valves.
- Quick wiring permits ease of installation.

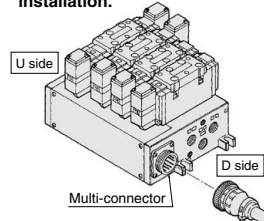

**VV5FR4-01CD-051-03**

VFR4000 Series Manifold  
Plug-in type with multi-connector

**Stations**

02	2 stations
:	:
08	8 stations

\* Max: 8 stations

**Connector mounting direction**

D	D side mounting
U	U side mounting

**Symbol**

Symbol	Passage		Porting specifications (A, B)
	P	EA, EB	
1	Common	Common	Side
2	Common	Common	Bottom *

\* Semi-standard

**Thread type**

Nil	Rc
F	G
N	NPT
T	NPTF

**Port size**

Symbol	P, EA, EB	A, B *
03	1/2	3/8
04	1/2	1/2
M		Mixed

\* For bottom ported: Rc 3/8 only.

**CE-compliant**

Nil	—
Q	CE-compliant



# VFR4000 Series



Note) Electrical entry and light/surge voltage suppressor: D/DZ/DO/DOZ, Y/YZ/YO/YOZ, F, FZ only.

[Option]

## Plug-in Type: With D-sub Connector (For wiring specifications, refer to page 1113.)

- Wide range of interchangeability (D-sub connector (25P) conforming to MIL standard)
- Quick wiring permits easier installation.

VV5FR4 - 01F D - 06 1 - 03

VFR4000 Series Manifold  
Plug-in type with D-sub connector

Connector mounting direction  
D D side mounting  
U U side mounting

Stations  
02 2 stations  
: :  
08 \* 8 stations  
\* Max: 8 stations

Thread type  
Nil Rc  
F G  
N NPT  
T NPTF

CE-compliant  
Nil —  
Q CE-compliant

Note) Electrical entry and light/surge voltage suppressor: F, FZ only.

Port size

Symbol	P, EA, EB	A, B *
03		3/8
04	1/2	1/2
M		Mixed

\* For bottom ported: Rc 3/8 only.

Symbol

Symbol	Passage	Porting specifications (A, B)	Side
1	Common	Common	Bottom *
2			

\* Semi-standard

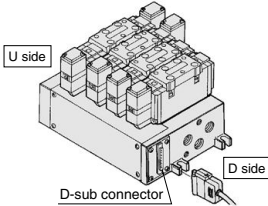

## Non Plug-in Type: Grommet Terminal, DIN Terminal (Common electrical entry)

- Individual wiring for every valve

VV5FR4 - 10 - 05 1 - 03

VFR4000 Series Manifold  
Non plug-in type Common electrical entry

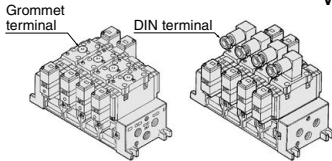

Stations  
02 2 stations  
: :  
10 10 stations

Thread type  
Nil Rc  
F G  
N NPT  
T NPTF

CE-compliant  
Nil —  
Q CE-compliant

Note) Electrical entry and light/surge voltage suppressor: D/DZ/DO/DOZ, Y/YZ/YO/YOZ only

Symbol

Symbol	Passage	Porting specifications (A, B)	Side
1	Common	Common	Bottom *
2			

\* Semi-standard

Port size

Symbol	P, EA, EB	A, B *
03		3/8
04	1/2	1/2
M		Mixed

\* For bottom ported: Rc 3/8 only.

## Non Plug-in Type: Grommet, Grommet Terminal, Conduit Terminal, DIN Terminal (Individual electrical entry)

- Individual wiring for every valve

VV5FR4 - 40 - 05 1 - 03

VFR4000 Series Manifold  
Non plug-in type Individual electrical entry

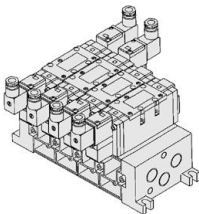

Stations  
02 2 stations  
: :  
10 10 stations

Thread type  
Nil Rc  
F G  
N NPT  
T NPTF

CE-compliant  
Nil —  
Q CE-compliant

Note) Electrical entry and light/surge voltage suppressor: D/DZ/DO/DOZ, Y/YZ/YO/YOZ only

Symbol

Symbol	Passage	Porting specifications (A, B)	Side
1	Common	Common	Bottom *
2			

\* Semi-standard

Port size

Symbol	P, EA, EB	A, B *
03		3/8
04	1/2	1/2
M		Mixed

\* For bottom ported: Rc 3/8 only.

Note) Manifold base is in common with VV5FR4-10.

Note) Manifold base is in common with VFS4000 series but the connection of terminal block for plug-in type is different.



**Manifold/Option Parts Assembly**

**Individual SUP spacer**

Setting individual SUP spacer on the manifold block enables individual SUP port for each valve.

Body type	Plug-in type	Non plug-in type
Part no.	VVFS4000-P-03-1	VVFS4000-P-03-2

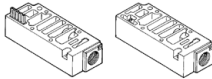

**Individual EXH spacer**

Setting individual EXH spacer on the manifold block enables individual EXH port for each valve.

Body type	Plug-in type	Non plug-in type
Part no.	VVFS4000-R-04-1	VVFS4000-R-04-2

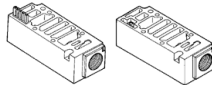

**SUP block disk**

When supplying manifold with more than two different pressures, high and low, insert a block disk in between stations subjected to plug-in different pressures.

Body type	Plug-in type	Non plug-in type
Part no.	AXT634-10A	

**EXH block disk**

When valve exhaust affects the other stations on the circuit, insert EXH block disk in between stations to separate valve exhaust.

Body type	Plug-in type	Non plug-in type
Part no.	AXT634-11A	

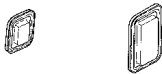

EXH block disk      SUP block disk

**Throttle valve spacer**

Needle valve set on the manifold block can control cylinder speed by throttling exhaust.

Body type	Plug-in type	Non plug-in type
Part no.	VVFS4000-20A-1	VVFS4000-20A-2

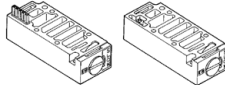

**Interface regulator**

Interface regulator set on the manifold block can regulate pressure for each valve. (Refer to "Flow Rate Characteristics" on page 1111 before operation.)

Body type	Plug-in type	Non plug-in type
P port regulation	ARBF4050-00-P-1	ARBF4050-00-P-2
A port regulation	ARBF4050-00-A-1	ARBF4050-00-A-2
B port regulation	ARBF4050-00-B-1	ARBF4050-00-B-2

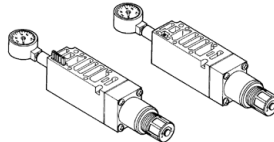

**Blanking plate**

It is used by attaching on the manifold block for being prepared for removing a valve for maintenance reasons or planning to mount a spare valve, etc.

Body type	Plug-in type	Non plug-in type
Part no.	VVFS4000-10A	

**Manifold Option**

**With exhaust cleaner**

- Valve exhaust noise dampening: 35 dB or more.
- Collects oil mist: collecting rate 99.9% or more
- Piping process reduced.

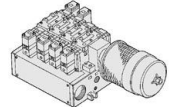

For details, refer to page 1076.

**With control unit**

- Plug-in type/Non plug-in type
- Filter, regulation valve, pressure switch and air release valve are all combined to form one unit.
- Piping processes are eliminated.

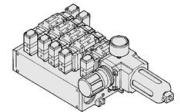

For details, refer to page 1079.

SV
SYJ
SZ
VF
VP4
VQ 1/2
VQ 4/5
VQC 1/2
VQC 4/5
VQZ
SQ
VFS
VFR
VQ7

# VFR4000 Series

## Manifold/Plug-in Type

With terminal block: **VV5FR4-01T-Station 1-Port size**

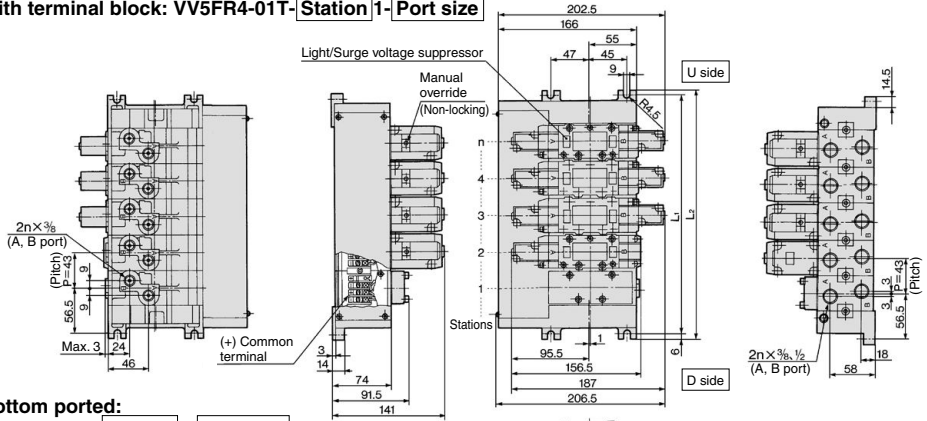

Bottom ported:  
**VV5FR4-01T-Station 2-Port size**

n: Station	2	3	4	5	6	7	8	9	10	Formula
L <sub>1</sub>	156	199	242	285	328	371	414	457	500	L <sub>1</sub> = 43 x n + 70
L <sub>2</sub>	168	211	254	297	340	383	426	469	512	L <sub>2</sub> = 43 x n + 82

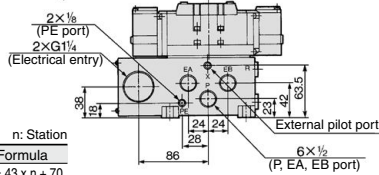

With multi-connector: **VV5FR4-01CD-Station 1-Port size**, **VV5FR4-01CU-Station 1-Port size**

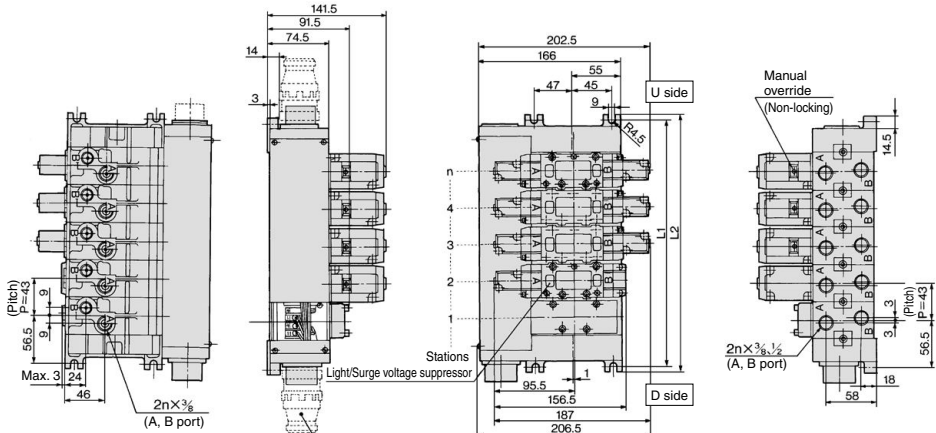

Bottom ported:  
**VV5FR4-01CD-CU-Station 2-Port size**

For wiring specifications, refer to page 1113.

n: Station	2	3	4	5	6	7	8	9	10	Formula
L <sub>1</sub>	156	199	242	285	328	371	414	457	500	L <sub>1</sub> = 43 x n + 70
L <sub>2</sub>	168	211	254	297	340	383	426	469	512	L <sub>2</sub> = 43 x n + 82

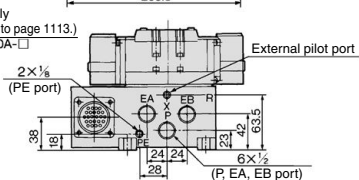

# 5 Port Pilot Operated Solenoid Valve Rubber Seal, Plug-in/Non Plug-in **VFR4000 Series**

## Manifold/Plug-in Type

With D-sub connector: **VV5FR4-01FD-Station 1-Port size**, **VV5FR4-01FU-Station 1-Port size**

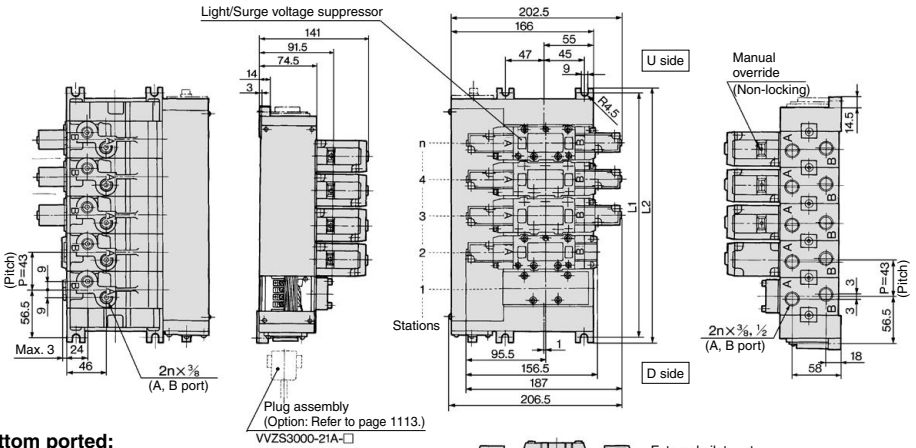

**Bottom ported:**  
**VV5FR4-01FD-Station 2-Port size**

For wiring specifications, refer to page 1113.

		n: Station								Formula
L	Station	2	3	4	5	6	7	8		
L <sub>1</sub>		156	199	242	285	328	371	414	L <sub>1</sub> = 43 x n + 70	
L <sub>2</sub>		168	211	254	297	340	383	426	L <sub>2</sub> = 43 x n + 82	

## Manifold/Non Plug-in Type

**VV5FR4-10-Station 1-Port size**

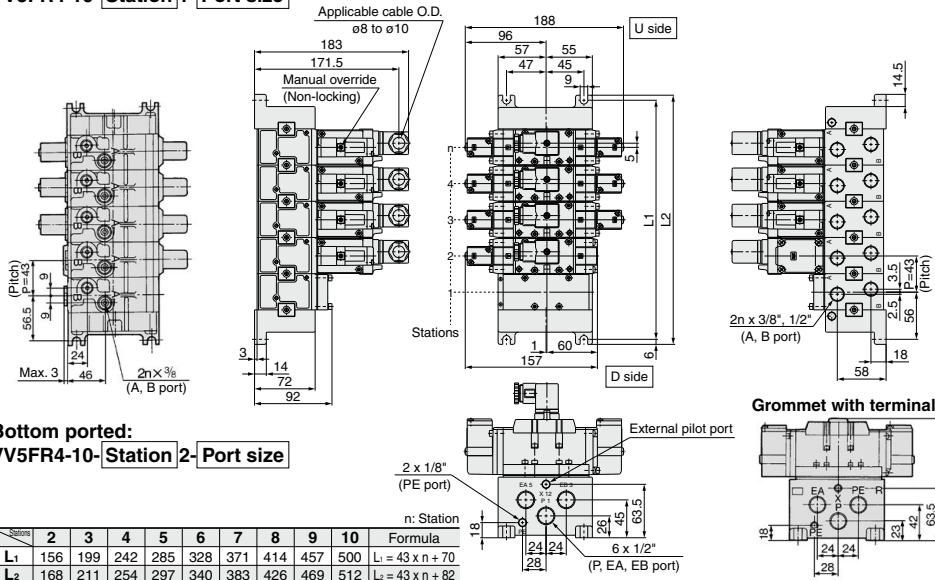

**Bottom ported:**  
**VV5FR4-10-Station 2-Port size**

		n: Station										Formula
L	Station	2	3	4	5	6	7	8	9	10		
L <sub>1</sub>		156	199	242	285	328	371	414	457	500	L <sub>1</sub> = 43 x n + 70	
L <sub>2</sub>		168	211	254	297	340	383	426	469	512	L <sub>2</sub> = 43 x n + 82	

- SV
- SYJ
- SZ
- VF
- VP4
- VQ 1/2
- VQ 4/5
- VQC 1/2
- VQC 4/5
- VQZ
- SQ
- VFS
- VFR
- VQ7

# VFR4000 Series

## Manifold/Non Plug-in Type

### VV5FR4-40-Station 1- Port size

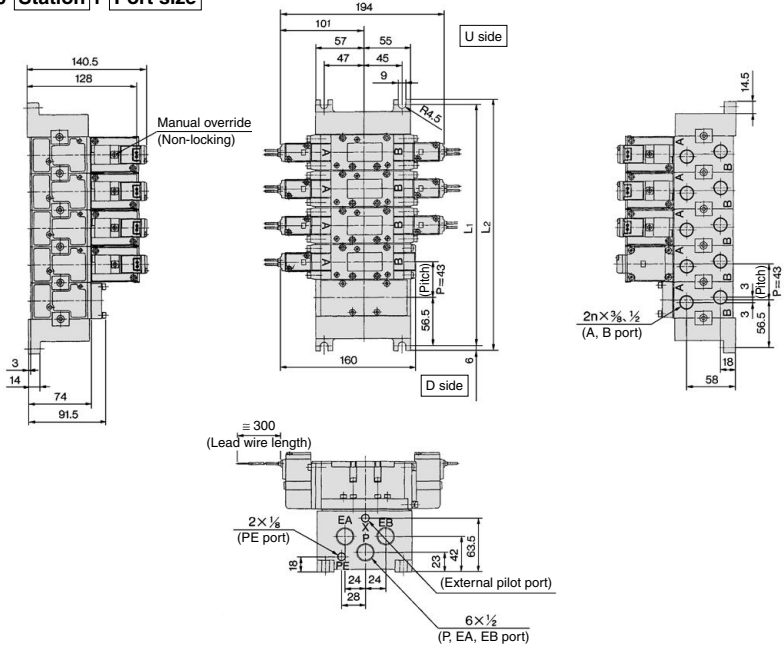

n: Stations	2	3	4	5	6	7	8	9	10	Formula
L <sub>1</sub>	156	199	242	285	328	371	414	457	500	L <sub>1</sub> = 43 x n + 70
L <sub>2</sub>	168	211	254	297	340	383	426	469	512	L <sub>2</sub> = 43 x n + 82

### E: Grommet terminal

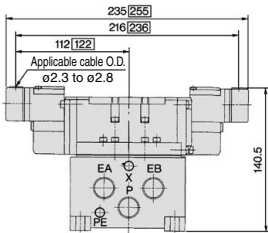

With light/surge voltage suppressor

### T: Conduit terminal

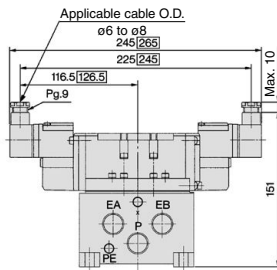

With light/surge voltage suppressor

### D, Y: DIN terminal

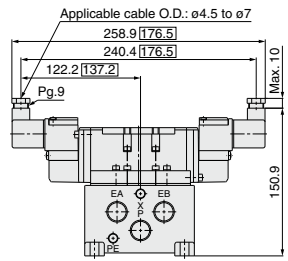

With light/surge voltage suppressor

**Manifold/Option Parts Assembly: Plug-in Type/Non Plug-in Type**

**Individual SUP spacer:**  
VVFS4000-P-03-1 (Plug-in type)  
VVFS4000-P-03-2 (Non plug-in type)

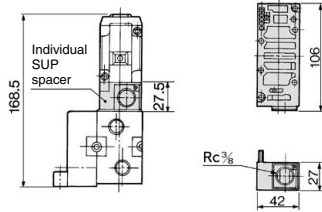

**Individual EXH spacer:**  
VVFS4000-R-04-1 (Plug-in type)  
VVFS4000-R-04-2 (Non plug-in type)

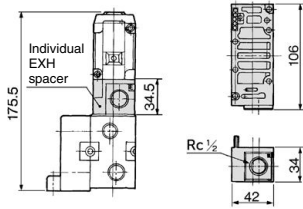

**SUP block disk: AXT634-10A**  
**EXH block disk: AXT634-11A**

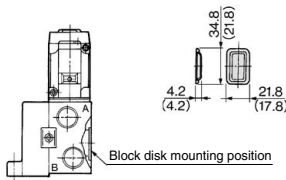

Note) Used with exclusive manifold block ( ): EXH block disk

**Throttle valve spacer:**  
VVFS4000-20A-1 (Plug-in type)  
VVFS4000-20A-2 (Non plug-in type)

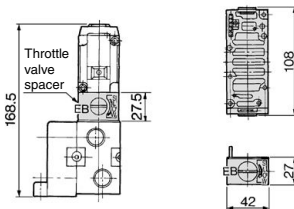

**Interface regulator/P port regulation:**  
ARBF4050-00-P-1 (Plug-in type)  
ARBF4050-00-P-2 (Non plug-in type)

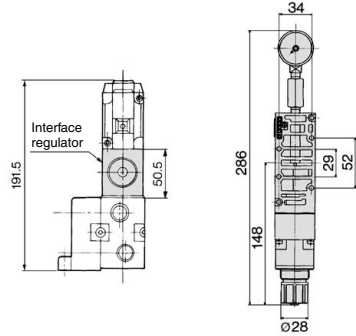

**Interface regulator/A port regulation:**  
ARBF4050-00-A-1 (Plug-in type)  
ARBF4050-00-A-2 (Non plug-in type)

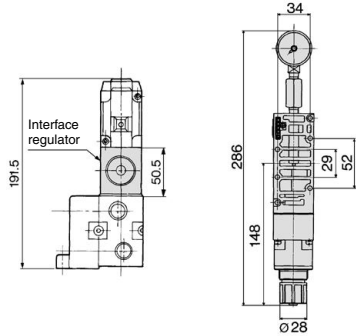

**Interface regulator/B port regulation:**  
ARBF4050-00-B-1 (Plug-in type)  
ARBF4050-00-B-2 (Non plug-in type)

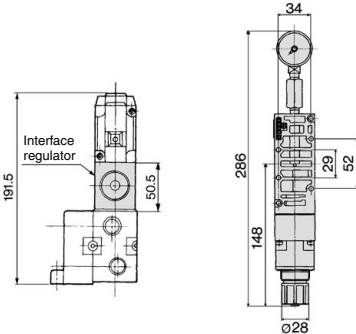

SV
SYJ
SZ
VF
VP4
VQ 1/2
VQ 4/5
VQC 1/2
VQC 4/5
VQZ
SQ
VFS
VFR
VQ7

Dimensions: FZ type dimensions of direct manual type are also the same.



# VFR4000 Series

## Manifold with Exhaust Cleaner

- Serves to protect working environment.
- Valve exhaust noise dampening: 35 dB or more.
- Collection rate of drainage and oil mist: 99.9% or more.
- Piping work is reduced.

### Manifold Specifications

Manifold	Plug-in type: <b>VV5FR4-01□(-Q)</b>	Non plug-in type: <b>VV5FR4-10(-Q)</b>	Non plug-in type: <b>VV5FR4-40(-Q)</b>
Wiring	With terminal block With multi-connector With D-sub connector	DIN terminal Grommet terminal	Grommet, Grommet terminal, Conduit terminal, DIN terminal
Applicable valve model	VFR4□0□□-□F(-Q)	VFR4□1□□-□D(-Q) VFR4□1□□-□E	VFR4□4□□-□G, VFR4□4□□-□E VFR4□4□□-□T, VFR4□4□□-□D(-Q)
Porting specifications	Common SUP, Common EXH		
	A, B port	Side: 3/8, 1/2 Bottom: 3/8 (Option)	
	P port	Side: 1/2 EXH 1 1 1/2	
Stations	2 to 10 stations (With multi-connector/D-sub connector: 2 to 8 stations)		
Applicable exhaust cleaners	AMC610-10 (Port size: R 1), AMC810-14 (Port size: R 1 1/2) <sup>(1)</sup>		

Note 1) Use "AMC810-14" when used with 5 or more stations or in high frequency.  
Exhaust cleaner "AMC610-10" and "AMC810-14" are not attached.

Note) Electrical entry and light/surge voltage suppressor: D/DZ/DO/DOZ, Y/YZ/YO/YOZ, F, FZ only.



### How to Order

**VV5FR4 - 10 - 06 1 - 03 - CD -**

VFR4000 Series Manifold

#### Base type/Electrical entry

01T	Plug-in type with terminal block
01C	Plug-in type with multi-connector
01F	Plug-in type with D-sub connector
10	Non plug-in type Common electrical entry
40	Non plug-in type Individual electrical entry

#### Connector mounting direction

Symbol	With connector	Applicable base
Nil	None	01T, 10, 40
D	D side mounting	01C, 01F
U	U side mounting	

#### Stations

02	2 stations
⋮	⋮
10 <sup>Note)</sup>	10 stations

Note) • Base 01T/10/40: 2 to 10 stations  
• Base 01C/01F: 2 to 8 stations

#### Thread type

Nil	Rc
F	G
N	NPT
T	NPTF

#### Exhaust cleaner mounting direction

Symbol	Exhaust cleaner mounting direction
CD	D side D side mounting
CU	U side U side mounting

\* Please indicate size or port size of exhaust cleaner.

#### Port size

Symbol	P, EA, EB	A, B *
03		3/8
04	1/2	1/2
M		Mixed

\* For bottom ported: Rc 3/8 only.

#### Symbol

Symbol	Passage		Porting specifications (A, B)
	P	EA, EB	
1	Common	Common	Side
2	Common	Common	Bottom *

\* Semi-standard

#### CE-compliant

Nil	—
Q	CE-compliant

Note) Electrical entry and light/surge voltage suppressor: D/DZ/DO/DOZ, Y/YZ/YO/YOZ, F, FZ only.

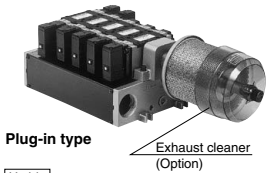

Plug-in type

U side

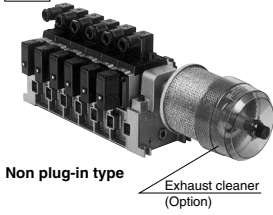

Non plug-in type

D side

## How to Order Manifold Assembly

<Example> Plug-in type with terminal block (6 stations)

VV5FR4-01T-061-03-CD (-Q) ...	1 set (Manifold base part no.)
*VFR4100-5FZ (-Q) .....	3 sets (2 position single part no.)
*VFR4200-5FZ (-Q) .....	2 sets (2 position double part no.)
*VVFS4000-10A .....	1 set (Blanking plate assembly part no.)
*AMC610-10 .....	1 set (Exhaust cleaner part no.)

↳ The asterisk denotes the symbol for assembly. Prefix it to the part nos. of the solenoid valve, etc.

Valve arrangement is counted from the D side.  
When ordering, specify the part nos. in order from the 1st. station in the D side.  
When entry of part numbers becomes complicated, indicate on the manifold specification sheet.

<Example> Non plug-in type: 6 stations

VV5FR4-10-061-03-CU (-Q) .....	1 set (Manifold base part no.)
*VFR4110-5E (-Q) .....	3 sets (2 position single part no.)
*VFR4210-5E (-Q) .....	2 sets (2 position double part no.)
*VVFS4000-10A .....	1 set (Blanking plate assembly part no.)
*AMC810-14 .....	1 set (Exhaust cleaner part no.)

↳ The asterisk denotes the symbol for assembly. Prefix it to the part nos. of the solenoid valve, etc.

Valve arrangement is counted from the D side.  
When ordering, specify the part nos. in order from the 1st. station in the D side.  
When entry of part numbers becomes complicated, indicate on the manifold specification sheet.

### ⚠ Caution

When using an exhaust cleaner, mount it downwards.

Refer to Best Pneumatics No. 7 for Exhaust Cleaner details.



# 5 Port Pilot Operated Solenoid Valve Rubber Seal, Plug-in/Non Plug-in **VFR4000 Series**

## Manifold with Exhaust Cleaner: Plug-in Type/Non Plug-in Type

Plug-in type: VV5FR4-01T-Station 1-Port size- $\frac{CD}{CU}$

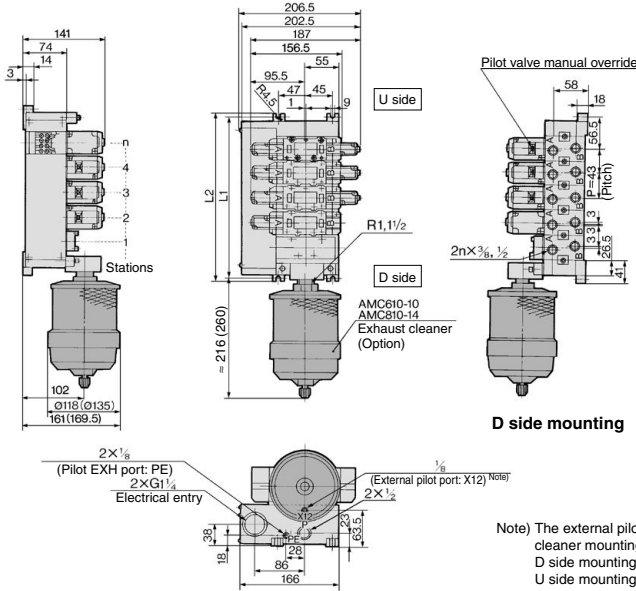

( ) : AMC810

Non plug-in type: VV5FR4-10-Station 1-Port size- $\frac{CD}{CU}$

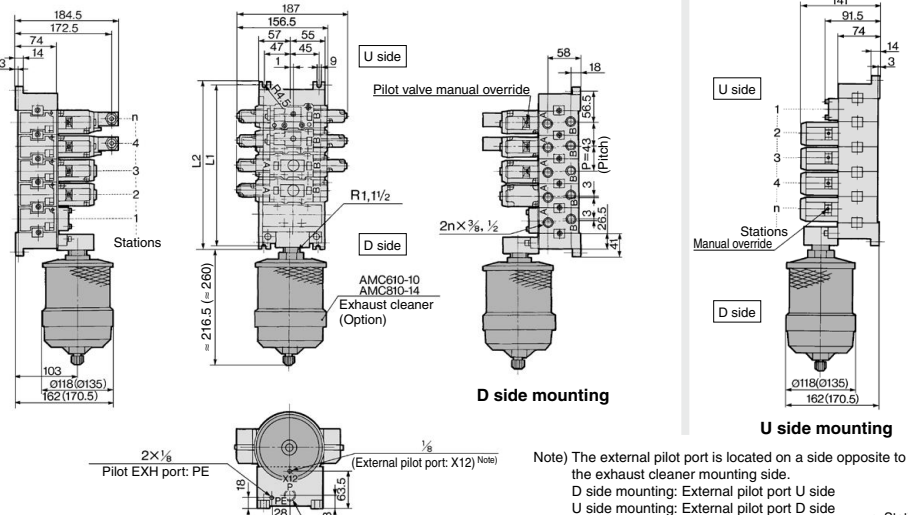

( ) : AMC810

SV
SYJ
SZ
VF
VP4
VQ 1/2
VQ 4/5
VQC 1/2
VQC 4/5
VQZ
SQ
VFS
VFR
VQ7

Note) The external pilot port is located on a side opposite to the exhaust cleaner mounting side.  
D side mounting: External pilot port U side  
U side mounting: External pilot port D side

Station	2	3	4	5	6	7	8	9	10	Formula
L <sub>1</sub>	156	199	242	285	328	371	414	457	500	L <sub>1</sub> = 43 x n + 70
L <sub>2</sub>	168	211	254	297	340	383	426	469	512	L <sub>2</sub> = 43 x n + 82



# VFR4000 Series

## Manifold with Exhaust Cleaner: Non Plug-in Type

Non plug-in type: VV5FR4-40- Station 1- Port size  $\frac{C}{C}$

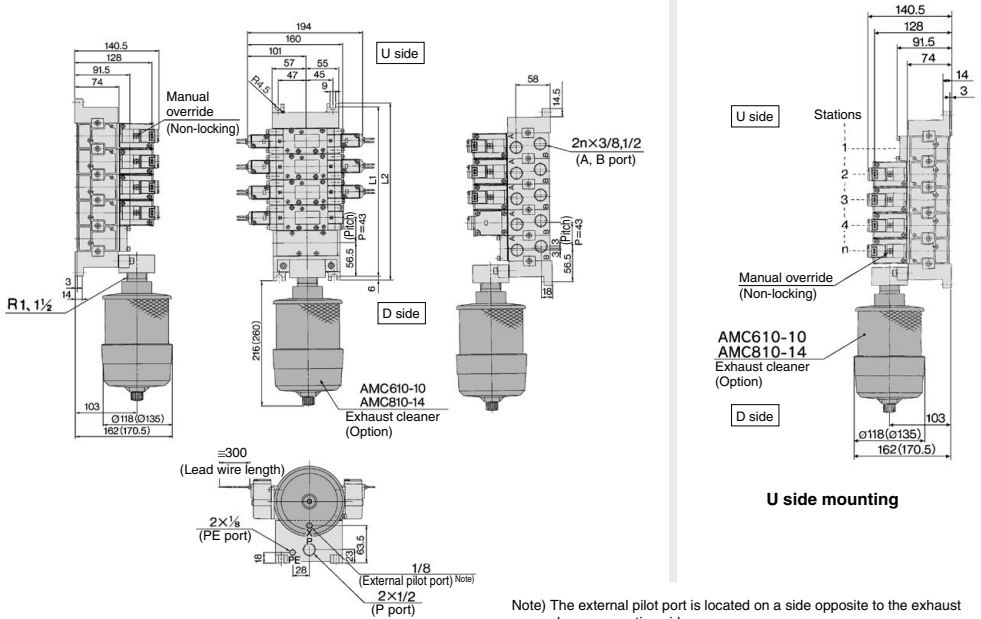

( ) : AMC810

										n: Station
Stations	2	3	4	5	6	7	8	9	10	Formula
L <sub>1</sub>	156	199	242	285	328	371	414	457	500	L <sub>1</sub> = 43 x n + 70
L <sub>2</sub>	168	211	254	297	340	383	426	469	512	L <sub>2</sub> = 43 x n + 82



## Manifold with Control Unit

- Control unit (Filter, Regulator, Pressure switch, Air release valve) are all standardized to the one unit, and can be mounted on the manifold base without any attachments.
- Piping processes are eliminated.

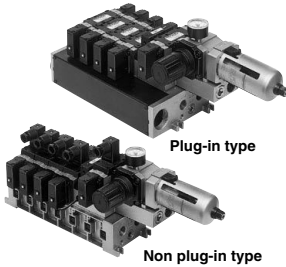

### ⚠ Caution

Air filter with auto-drain or manual drain must be mounted with the air filter at the bottom.

### Manifold Specifications

Manifold	Plug-in type: VV5FR4-01□(-Q)	Non plug-in type: VV5FR4-10(-Q)	Non plug-in type: VV5FR4-40(-Q)
<b>Wiring</b>	With terminal block With multi-connector With D-sub connector	DIN terminal Grommet terminal	Grommet, Grommet terminal, Conduit terminal, DIN terminal
<b>Applicable valve model</b>	VFR4□0□-□F(-Q)	VFR4□1□-□D(-Q) VFR4□1□-□E	VFR4□4□-□G, VFR4□4□-□E VFR4□4□-□T, VFR4□4□-□D(-Q)
<b>Porting specifications</b>	Common SUP, Common EXH		
	A, B port P, EA, EB port	Side: 3/8, 1/2, Bottom: 3/8 Side: 1/2	
<b>Stations</b>	2 to 10 (With multi-connector/D-sub connector: 2 to 8) *		

\* Including station of control unit

### Control Unit Specifications

Air filter (With auto-drain/With manual drain)	
<b>Filtration degree</b>	5 μm
Regulator	
<b>Set pressure (Outlet pressure)</b>	0.05 to 0.85 MPa
Pressure switch	
<b>Set pressure range: OFF</b>	0.1 to 0.6 MPa
<b>Differential</b>	0.08 MPa
<b>Contact</b>	1a
<b>Indicator light</b>	LED (RED)
<b>Max. switch capacity</b>	2 VA AC, 2 W DC
<b>Max. operating current</b>	24 VDC or less: 50 mA 100 VAC: 20 mA
<b>Inside voltage drop</b>	4 V or less
Air release valve (Single only)	
<b>Operating pressure range</b>	0.2 to 0.9 MPa

### Control Unit/Option

Air release valve spacer	(1) <Plug-in type> VVFS4000-24A-1R (D side mounting)	
	<Non plug-in type> VVFS4000-24A-2R (D side mounting)	
Pressure switch	(2) IS1000P-2-1	
Blanking plate	For filter regulator	MP2-3
	For pressure switch	MP3-2
	For air release valve	VVFS4000-24A-10
Filter element	11104-5B	

Note 1) Combining valve "VFR41□□" (single) and release valve spacer makes it possible to use this as an air release valve.

Note 2) Pressure switch cannot be mounted later on non plug-in type.

SV

SYJ

SZ

VF

VP4

VQ 1/2

VQ 4/5

VQC 1/2

VQC 4/5

VQZ

SQ

VFS

VFR

VQ7

# VFR4000 Series

Note) Electrical entry and light/surge voltage suppressor: D/DZ/DO/DOZ, Y/YZ/YO/YOZ, F, FZ only.



## How to Order

VV5FR4 - 01C D - 08 1 - 03 - AP -

VFR4000 Series Manifold

### Base type/Electrical entry

01T	Plug-in type with terminal block
01C	Plug-in type with multi-connector
01F	Plug-in type with D-sub connector
10	Non plug-in type (Common entry)
40	Non plug-in type (Individual entry)

### Connector mounting direction

Symbol	With connector	Applicable base
NII	None	01T, 10, 40
D	D side mounting	01C, 01F
U	U side mounting	

### Stations

02	2 stations
:	:
10	10 stations

- Note) • Base 01T/10/40: 2 to 10 stations  
 • Base 01C/01F: 2 to 8 stations  
 • Including stations of control unit.

### Symbol

Symbol	Passage		Porting specifications (A, B)
	P	EA, EB	
1	Common	Common	Side
2			Bottom *

\* Semi-standard

### Port size

Symbol	P, EA, EB	A, B
03		3/8
04	1/2	1/2
M		Mixed

\* For bottom ported: only 3/8

### CE-compliant

NII	—
Q	CE-compliant

Note) Electrical entry and light/surge voltage suppressor: D/DZ/DO/DOZ, Y/YZ/YO/YOZ, F, FZ only.

### Air release valve coil rating

NII	None
1	100 VAC, 50/60 Hz
5	24 VDC

Note 1) Adjust the voltage to the coil rated voltage of the mounted valve.  
 Note 2) For other rated voltages, please consult with SMC.

### Control unit type

Control equipment	Symbol	NII	MP	AP	M	A	G	F	C	E
Air release valve		●	●	●	●					●
Air filter regulator with manual drain			●				●			
Air filter regulator with auto-drain			●				●			
Pressure switch			●							
Blanking plate (Air release valve)								●	●	
Blanking plate (Filter regulator)										●
Blanking plate (Pressure switch)					●	●	●	●	●	
Required stations					2 stations					1 station

Note) Control unit is D side mounting only.

### Thread type

NII	Rc
F	G
N	NPT
T	NPTF

## How to Order Manifold Assembly

<Example> Plug-in type with terminal block

VV5FR4-01T-081-03-AP5 (-Q) .....	1 set (Manifold base part no.)
*VFR4100-5FZ (-Q) .....	4 sets (2 position single part no.)
*VFR4200-5FZ (-Q) .....	2 sets (2 position double part no.)

↳ The asterisk denotes the symbol for assembly. Prefix it to the part nos. of the solenoid valve, etc.

The 1st and 2nd station are used for control unit mounting.  
 When ordering, specify the part nos. in order from the 3rd. station in the D side.  
 When entry of part numbers becomes complicated, indicate on the manifold specification sheet.

<Example> Non plug-in type

VV5FR4-10-061-03-A5 (-Q) .....	1 set (Manifold base part no.)
*VFR4110-5D (-Q) .....	4 sets (2 position single part no.)

↳ The asterisk denotes the symbol for assembly. Prefix it to the part nos. of the solenoid valve, etc.

The 1st and 2nd station are used for control unit mounting.  
 When ordering, specify the part nos. in order from the 3rd. station in the D side.  
 When entry of part numbers becomes complicated, indicate on the manifold specification sheet.

## Manifold with Control Unit: Plug-in Type/Non Plug-in Type

Plug-in type:

VV5FR4-01T-Station 1-Port size-AP Voltage of air release valve

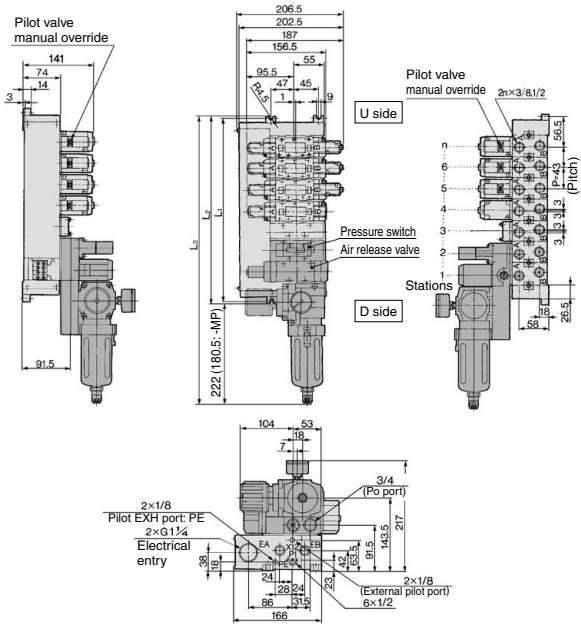

Example for manifold

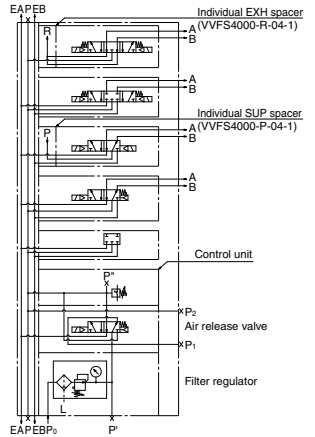

- SV
- SYJ
- SZ
- VF
- VP4
- VQ 1/2
- VQ 4/5
- VQC 1/2
- VQC 4/5
- VQZ
- SQ
- VFS
- VFR
- VQ7

Non plug-in type:

VV5FR4-10-Station 1-Port size-AP Voltage of air release valve

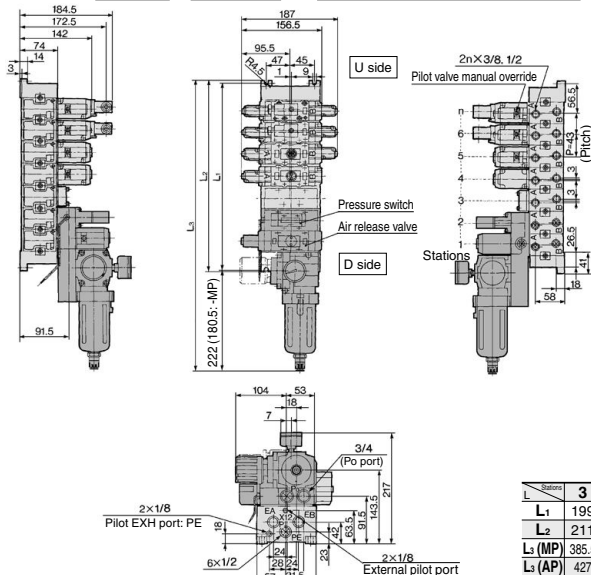

Example for manifold

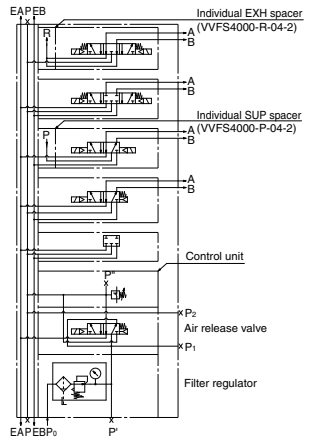

		n: Station									
L	Stations	3	4	5	6	7	8	9	10	Formula	
L <sub>1</sub>	199	242	285	328	371	414	457	500	543	L <sub>1</sub> = 43 x n + 70	
L <sub>2</sub>	211	254	297	340	383	426	469	512	555	L <sub>2</sub> = 43 x n + 82	
L <sub>3</sub> (MP)	385.5	428.5	471.5	514.5	557.5	600.5	643.5	686.5	729.5	L <sub>3</sub> = 43 x n + 256.5	
L <sub>3</sub> (AP)	427	470	513	556	599	642	685	728	771	L <sub>3</sub> = 43 x n + 298	



# VFR4000 Series

## Manifold with Control Unit: Non Plug-in Type

Non plug-in type: VV5FR4-40-Station 1-Port size-AP Voltage of air release valve

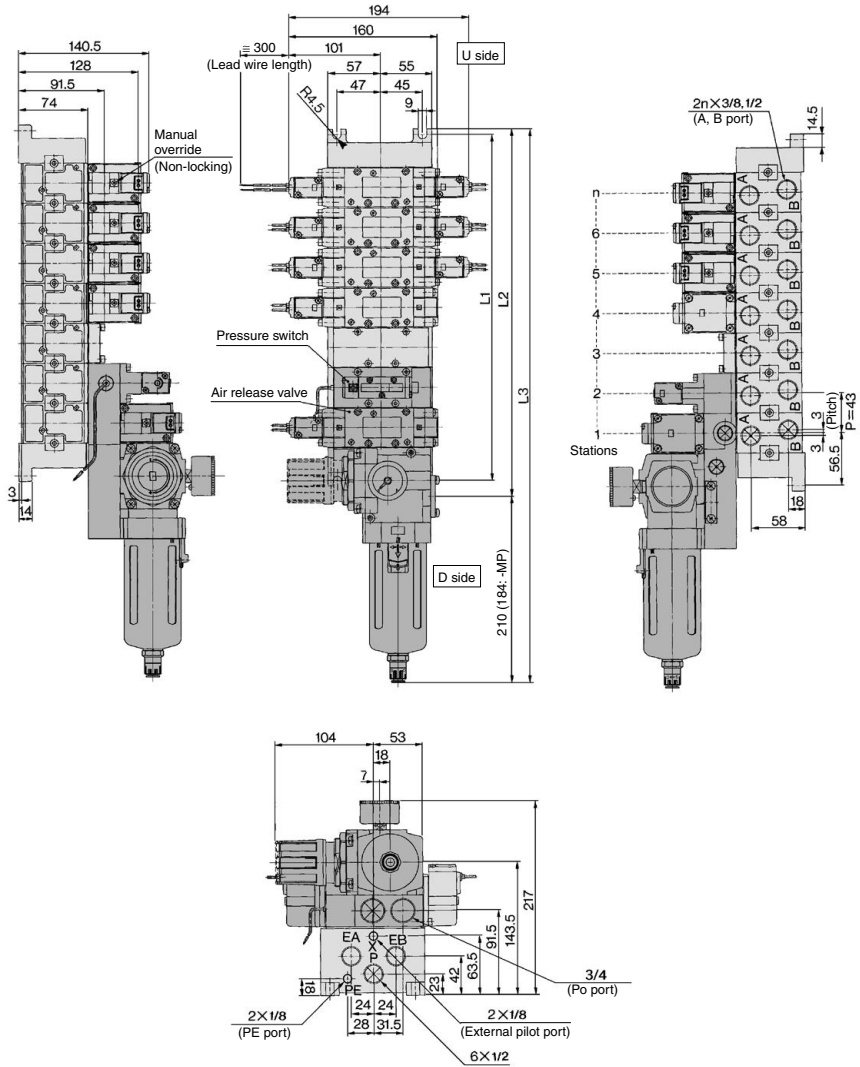

n: Station

Stations	3	4	5	6	7	8	9	10	Formula
L <sub>1</sub>	199	242	285	328	371	414	457	500	L <sub>1</sub> = 43 x n + 70
L <sub>2</sub>	211	254	297	340	383	426	469	512	L <sub>2</sub> = 43 x n + 82
L <sub>3</sub> (MP)	385.5	428.5	471.5	514.5	557.5	600.5	643.5	686.5	L <sub>3</sub> = 43 x n + 256.5
L <sub>3</sub> (AP)	427	470	513	556	599	642	685	728	L <sub>3</sub> = 43 x n + 298

**Manifold Base Construction: Plug-in Type/Non Plug-in Type**

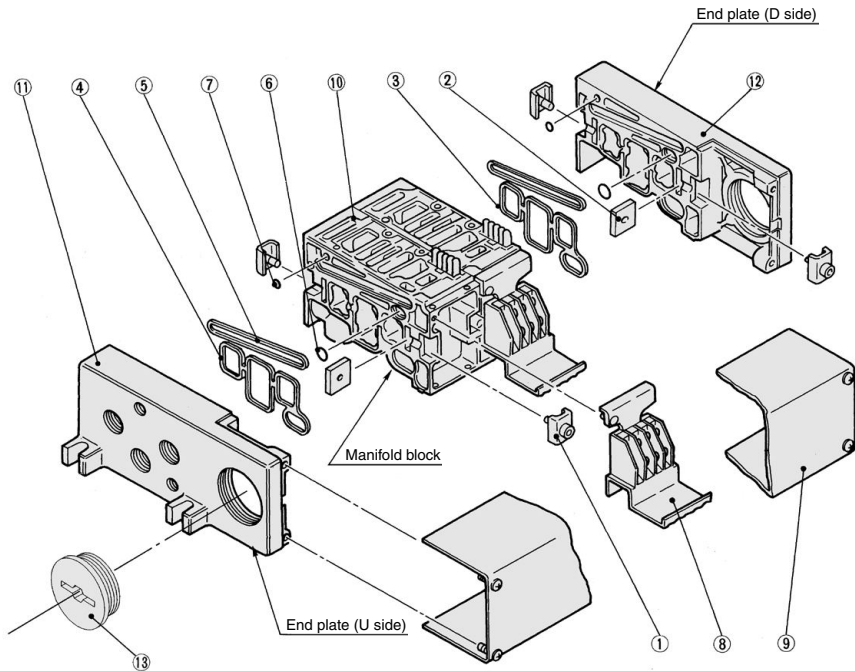

SV
SYJ
SZ
VF
VP4
VQ 1/2
VQ 4/5
VQC 1/2
VQC 4/5
VQZ
SQ
VFS
<b>VFR</b>
VQ7

**Replacement Parts**

No.	Description	Material	Part no.
1	Connection fitting A	Steel	VVF4000-5-1A
2	Connection fitting B	Steel	VVF4000-5-2
3	Gasket	NBR	VVF4000-7 (for end plate)
4	Gasket	NBR	VVF4000-7-1 (for manifold block)
5	Gasket	NBR	VVF4000-8
6	O-ring	NBR	KA01579M
7	O-ring	NBR	KA00078
8	Terminal assembly	—	VFR4000-14-1A
9	Junction cover assembly	—	For 01T VVF4000-4A- (Stations)
13	Rubber plug	NBR	AXT336-9

Note) Manifold Base/Construction: Plug-in type with terminal block.

**Replacement Parts: Sub Assembly**

No.	Description	Assembly part no.	Component parts	Applicable manifold base
10	Manifold block assembly <sup>(Note)</sup>	VFR4000-19-1A-03	Manifold block (10), Terminal (8), Connection bracket (1, 2), Gasket (4, 5), O-ring (6, 7), Receptacle assembly	Plug-in type
		VFR4000-19-2A-03	Manifold block (10), Connection bracket (1, 2), Gasket (4, 5), O-ring (6, 7)	Non plug-in type
11	End plate (U side) assembly	VVF4000-2A-1	End plate (U) (11), Metal joint (1, 2)	Plug-in type
		VVF4000-2A-2	End plate (U) (11), Metal joint (1, 2)	Non plug-in type
12	End plate (D side) assembly	VVF4000-3A-1	End plate (D) (12), Connection bracket (1, 2), Gasket (3, 4), O-ring (6, 7)	Plug-in type
		VVF4000-3A-2	End plate (D) (12), Connection bracket (1, 2), Gasket (3, 5), O-ring (6, 7)	Non plug-in type

Note) For side ported

\* Contact SMC for CE-compliant products.

# 5 Port Pilot Operated Solenoid Valve Rubber Seal, Plug-in/Non Plug-in VFR5000 Series

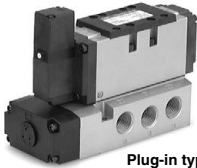

Plug-in type



Non plug-in type

## Symbol

2 position	3 position
Single	Closed center
(A)4 2(B)  (EA)5 1 3(EB) (P)	(A)4 2(B)  (EA)5 1 3(EB) (P)
Double	Exhaust center
(A)4 2(B)  (EA)5 1 3(EB) (P)	(A)4 2(B)  (EA)5 1 3(EB) (P)
	Pressure center
	(A)4 2(B)  (EA)5 1 3(EB) (P)

## Standard Specifications

Valve specifications	Fluid		Air
	Operating pressure range	2 position single/3 position	0.2 to 0.9 MPa
		2 position double	0.1 to 0.9 MPa
	Ambient and fluid temperature		-10 to 50°C (No freezing.)
	Lubrication		Non-lube <sup>(1)</sup>
	Manual override		Non-locking push type
Mounting orientation		Unrestricted	
Impact/Vibration resistance		300/50m/s <sup>2</sup> <sup>(2)</sup>	
Enclosure		Dustproof	
Electricity specifications	Coil rated voltage		100, 200 VAC (50/60 Hz), 24 VDC
	Allowable voltage fluctuation		-15 to -10% of rated voltage
	Apparent power (AC) <sup>(3)</sup>	Inrush	5.6 VA/50 Hz, 5.0 VA/60 Hz
		Holding	3.4 VA/50 Hz, 2.3 VA/60 Hz
	Power consumption (DC) <sup>(3)</sup>		1.8 W (2.04 W: With light/surge voltage suppressor)
	Electrical entry		Plug-in type Conduit terminal Non plug-in type Grommet terminal, DIN terminal

Note 1) Use turbine oil Class 1 (ISO VG32), if lubricated. Note 3) At rated voltage  
 Note 2) Impact resistance: No malfunction occurred when it is tested with a drop tester in the axial direction and at the right angles to the main valve and armature in both energized and de-energized states every once for each condition. (Values at the initial period)  
 Vibration resistance: No malfunction occurred in a one-sweep test between 45 and 2000 Hz. Test was performed at both energized and de-energized states in the axial direction and at the right angles to the main valve and armature. (Values at the initial period)

## Option Specifications

Pilot type		External pilot Note)
Manual override	Main valve	Direct manual override
	Pilot valve	Non-locking push type A (Extended), Locking type B (Tool required), Locking type C (Lever)
Coil rated voltage		110 to 120, 220 VAC 50/60 Hz 12 VDC
Porting specifications		Bottom ported
Option		With light/surge voltage suppressor

Note) Operating pressure: Pilot pressure:  
 2 position 0 to 0.9 MPa 2 position single 0.2 to 0.9 MPa  
 3 position 0.15 to 0.9 MPa 2 position double 0.1 to 0.9 MPa  
 3 position 0.3 x P + 0.1 to 0.9 MPa  
 (P: Operating pressure)

## Model

Type of actuation	Model		Port size	Flow rate characteristics <sup>(1)</sup>						Max. <sup>(2)</sup> operating cycle (Hz)	Response <sup>(3)</sup> time (ms)	Weight <sup>(4)</sup> (kg)	
	Plug-in	Non plug-in		1 → 4/2 (P → A/B)			4/2 → 5/3 (A/B → EA/EB)						
				C [dm <sup>3</sup> /s-bar]	b	Cv	C [dm <sup>3</sup> /s-bar]	b	Cv				
2 position	Single	VFR510 □ VFR511 □	3/8	17	0.36	4.7	18	0.40	5.0	5	60 or less	1.77 (1.72)	
			1/2	20	0.28	5.2	23	0.32	6.2				
	Double	VFR520 □ VFR521 □	3/4	23	0.27	5.8	25	0.21	6.2	5	60 or less	1.88 (1.83)	
			3/8	16	0.37	4.6	18	0.41	5.1				
3 position	Closed center	VFR530 □ VFR531 □	1/2	17	0.31	4.6	20	0.33	5.4	3	80 or less	1.87 (1.82)	
			3/4	18	0.28	4.7	21	0.30	5.4				
	Exhaust center	VFR540 □ VFR541 □	3/8	14	0.38	3.6	17 [16]	0.39 [0.35]	4.8 [4.3]	3	80 or less	1.87 (1.82)	
			1/2	17	0.29	4.6	21 [18]	0.31 [0.34]	5.6 [5.0]				
	Pressure center	VFR550 □ VFR551 □	3/4	18	0.29	4.6	23 [20]	0.27 [0.33]	5.9 [5.2]	3	80 or less	1.87 (1.82)	
			3/8	16 [9.4]	0.39 [0.40]	4.2 [2.6]	17	0.36	4.5				
				1/2	18 [9.7]	0.32 [0.45]	5.0 [2.9]	20	0.31	5.3			
				3/4	19 [9.2]	0.35 [0.48]	5.4 [2.8]	21	0.29	5.6			

Note 1) [ ]: Denotes the normal position.

Note 2) Min. operating frequency is once in 30 days.

Note 3) Based on dynamic performance test, JIS B 8419: 2010. (Coil temperature: 20°C, at rated voltage, without surge voltage suppressor)

Note 4) For VFR5□□□-FZ-06, ( ): VFR5□□10□-DZ-06

# 5 Port Pilot Operated Solenoid Valve Rubber Seal, Plug-in/Non Plug-in **VFR5000 Series**



## How to Order

Note) Electrical entry and light/surge voltage suppressor: D, DZ, F, FZ only.

[Option]

**Electrical entry**

F: Plug-in type, conduit type

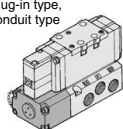

CE-compliant

**Option**

Nil	None
Z	With light/surge voltage suppressor

**Porting specifications**

Nil	Side ported
B*	Bottom ported

\* In the case of external pilot (Option), bottom piping is not available.

**Port size**

Nil	Without sub-plate
03	3/8
04	1/2
06	3/4

**Thread type**

Nil	Rc
F	G
N	NPT
T	NPTF

**Plug-in** VFR5  0  - 5 F  -  -  - 06  -

**Non plug-in** VFR5  1  - 1 D  -  -  - 06  -

**Symbol**

1	2 position single (A)4 2(B) (EA)5 1 3(EB) (P)
2	2 position double (A)4 2(B) (EA)5 1 3(EB) (P)
3	3 position closed center (A)4 2(B) (EA)5 1 3(EB) (P)
4	3 position exhaust center (A)4 2(B) (EA)5 1 3(EB) (P)
5	3 position pressure center (A)4 2(B) (EA)5 1 3(EB) (P)

**Body option**

0	Standard
1*	Direct manual override

\* Semi-standard

**Pilot type**

Nil	Internal pilot
R	External pilot

**Coil rated voltage**

1	100 VAC, 50/60 Hz
2	200 VAC, 50/60 Hz
3	110 to 120 VAC, 50/60 Hz
4	220 VAC, 50/60 Hz
5	24 VDC
6	12 VDC
7	240 VAC, 50/60 Hz

Note) Electrical entry: D, F only. For other rated voltages, please consult with SMC.

**Electrical entry**

E: Grommet terminal

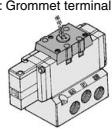

D: DIN terminal

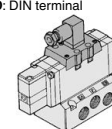

CE-compliant

**Pilot valve Manual override**

Nil: Non-locking push type



A\*: Non-locking push type A (Extended)



B\*: Locking type B (Tool required)



C\*: Locking type C (Lever)



\* Semi-standard

**CE-compliant**

Nil	—
Q	CE-compliant (Note)

Note) Electrical entry and light/surge voltage suppressor: D, DZ, F, FZ only.

SV
SYJ
SZ
VF
VP4
VQ 1/2
VQ 4/5
VQC 1/2
VQC 4/5
VQZ
SQ
VFS
VFR
VQ7

## How to Order Pilot Valve Assembly

SF4 - 1 F - 70 -

**Coil rated voltage**

Symbol	Rated voltage
1	100 VAC, 50/60 Hz
2	200 VAC, 50/60 Hz
3	110 to 120 VAC, 50/60 Hz
4	220 VAC, 50/60 Hz
5	24 VDC
6	12 VDC
7	240 VAC, 50/60 Hz

For other rated voltages, please consult with SMC.

**Manual override**

Nil	Non-locking push type
A	Non-locking push type A (Extended)
B	Locking type B (Tool required)
C	Locking type C (Lever)

**CE-compliant**

Nil	—
Q	CE-compliant



# VFR5000 Series

Use as a guide for selection.  
Please confirm the actual conditions with SMC Sizing Program.

## Cylinder Speed Chart

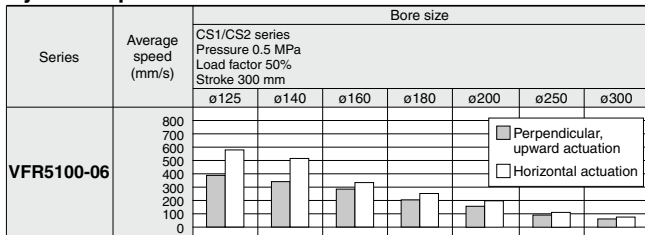

- \* It is when the cylinder is extending that is meter-out controlled by speed controller which is directly connected with cylinder, and its needle valve with being fully open.
- \* The average velocity of the cylinder is what the stroke is divided by the total stroke time.
- \* Load factor:  $((\text{Load mass} \times 9.8) / \text{Theoretical force}) \times 100\%$

## Conditions

		CS1/CS2 series
VFR5110-06	Tube x Length	SGP20A x 1 m
	Speed controller	AS500-06
	Silencer	AN500-06

## How to Order Sub-plate Assembly

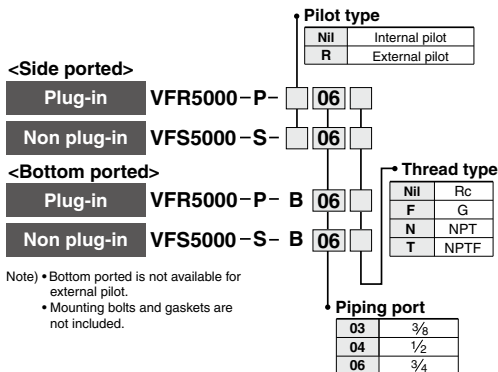



# 5 Port Pilot Operated Solenoid Valve Rubber Seal, Plug-in/Non Plug-in **VFR5000 Series**

## Construction

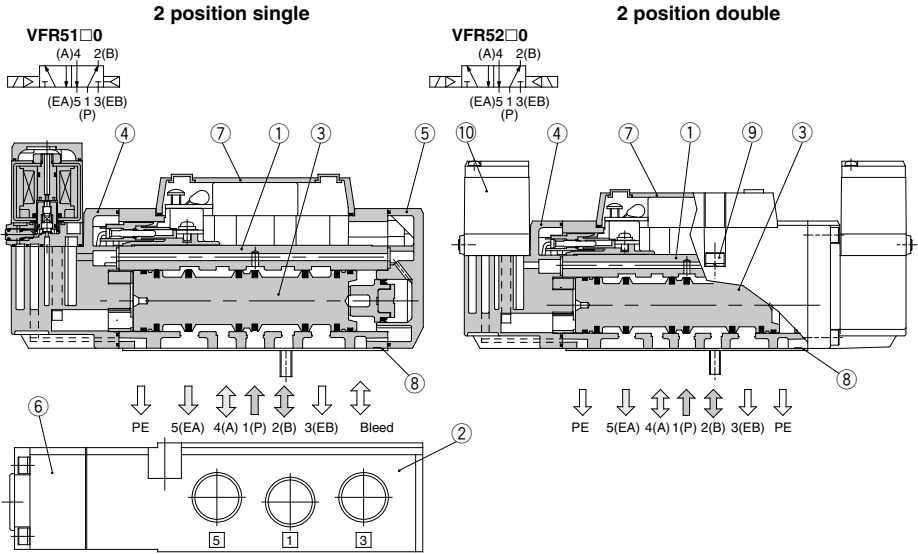

### 3 position closed center/exhaust center/pressure center

#### Closed center: VFR5300

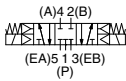

#### Exhaust center: VFR5400

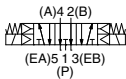

#### Pressure center: VFR5500

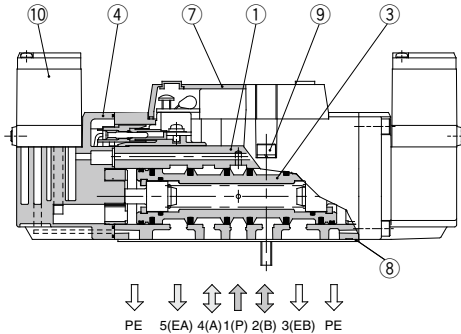
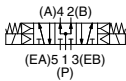

This figure shows a closed center type.

## Component Parts

No.	Description	Material	Note
1	Body	Aluminum die-casted	Platinum silver
2	Sub-plate	Aluminum die-casted	Platinum silver
3	Spool valve	Aluminum, NBR	
4	Adapter plate	Resin	Black

## Component Parts

No.	Description	Material	Note
5	End plate	Resin	Black
6	Junction cover	Resin	Black
7	Light cover	Resin	

## Replacement Parts

No.	Description	Material	Part no.		
			VFR5100	VFR5200	VFR5300/5400/5500
8	Gasket	NBR	AXT627-10-1	AXT627-10-1	AXT627-10-1
9	Hexagon socket head screw <small>(Note)</small>	Steel	AXT627-42-1#1 (M5 x 50)	AXT627-42-1#1 (M5 x 50)	AXT627-42-1#1 (M5 x 50)
10	Pilot valve assembly	—	Refer to "How to Order Pilot Valve Assembly" on page 1085.		

Note) For the VFR5000 series, it requires 4 pcs.



# VFR5000 Series

## Plug-in: 2 Position Single/Double, 3 Position Closed Center/Exhaust Center/Pressure Center

### 2 position single: VFR510<sup>0</sup>-□F(Z)

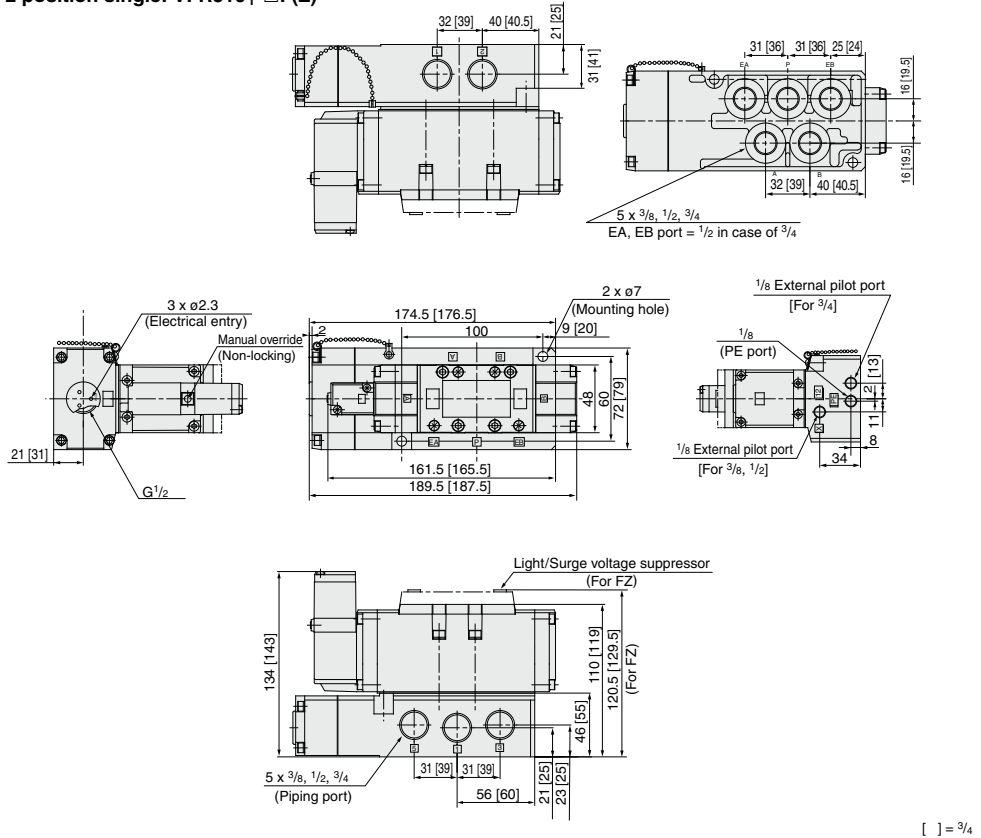

### 2 position double: VFR520<sup>0</sup>-□F(Z)

### 3 position closed center: VFR530<sup>0</sup>-□F(Z)

### 3 position exhaust center: VFR540<sup>0</sup>-□F(Z)

### 3 position pressure center: VFR550<sup>0</sup>-□F(Z)

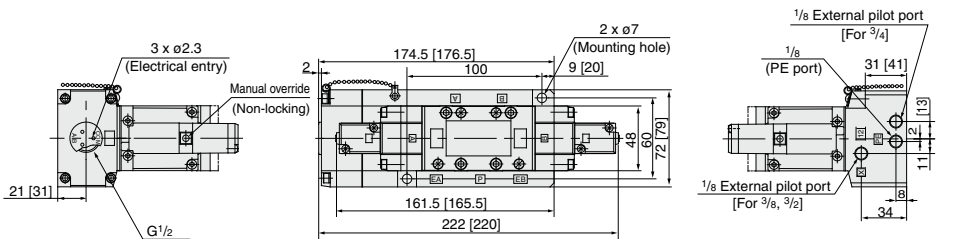

\* Other dimensions are the same as the single type.  
[ ] = 3/4

# 5 Port Pilot Operated Solenoid Valve Rubber Seal, Plug-in/Non Plug-in **VFR5000 Series**

## Plug-in: 2 Position Single/Double, 3 Position Closed Center/Exhaust Center/Pressure Center

2 position single: VFR511<sup>Q</sup>-□E, VFR511<sup>Q</sup>-□D(Z)

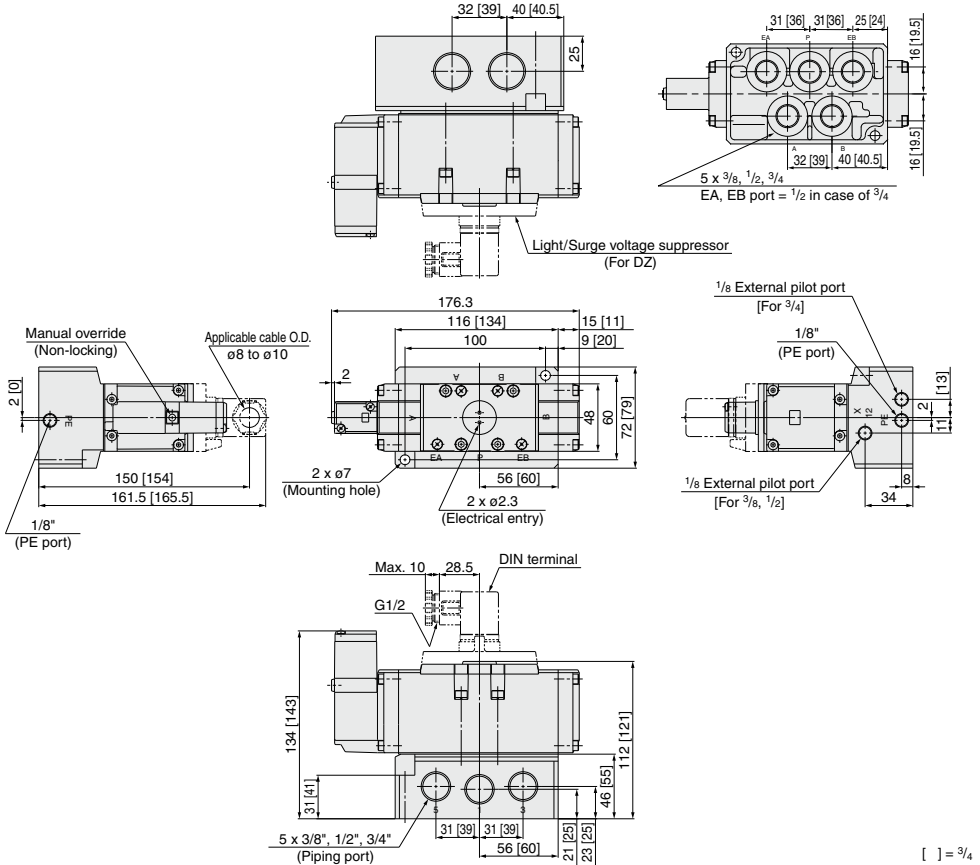

2 position double: VFR521<sup>Q</sup>-□E, VFR521<sup>Q</sup>-□D(Z)

3 position closed center: VFR531<sup>Q</sup>-□E, VFR531<sup>Q</sup>-□D(Z)

3 position exhaust center: VFR541<sup>Q</sup>-□E, VFR541<sup>Q</sup>-□D(Z)

3 position pressure center: VFR551<sup>Q</sup>-□E, VFR551<sup>Q</sup>-□D(Z)

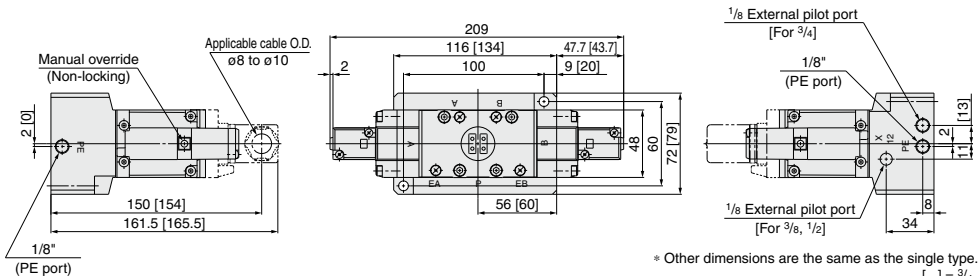

# VFR5000 Series Manifold Specifications



## Manifold Specifications

Base model	Wiring	Porting specifications		Port size Rc		Stations	Applicable valve model
		A, B port	Side/ Bottom	P, EA, EB	A, B		
Plug-in type VV5FR5-01□(-Q)	<ul style="list-style-type: none"> <li>• With terminal block</li> <li>• With multi-connector</li> <li>• With D-sub connector</li> </ul>	Side/ Bottom	3/4	1/2, 3/4	A, B	2 to 10	VFR5□□□□□□(-Q)
						2 to 8	
Non plug-in type VV5FR5-10(-Q)	<ul style="list-style-type: none"> <li>• Grommet terminal</li> <li>• DIN terminal</li> </ul>					2 to 10	

## How to Order Manifold Assembly

Instruct by specifying the valves, blanking plate and manifold option parts assembly to be mounted on the manifold along with the manifold base model no.

<Example> Plug-in type with terminal block: 6 stations

VV5FR5-10T-061-04 (-Q) .....	1 set (Manifold part number)
*VFR5100-5FZ (-Q) .....	3 sets (2 position single)
*VFR5200-5FZ (-Q) .....	2 sets (2 position double)
*VVFS5000-10A .....	1 set (Blanking plate assembly part no.)

↳ The asterisk denotes the symbol for assembly. Prefix it to the part nos. of the solenoid valve, etc.

Valve arrangement is counted from the D side.  
When ordering, specify the part nos. in order from the 1st. station in the D side.  
When entry of part numbers becomes complicated, indicate on the manifold specification sheet.

<Example> Non plug-in type: 6 stations

VV5FR5-10-061-04 (-Q) .....	1 set (Manifold part number)
*VFR5110-5D (-Q) .....	5 sets (2 position single)
*VFR5410-5D (-Q) .....	1 set (3 position exhaust center)
*VVFS5000-R-04-2 .....	1 set (Individual EXH spacer)

↳ The asterisk denotes the symbol for assembly. Prefix it to the part nos. of the solenoid valve, etc.

Valve arrangement is counted from the D side.  
When ordering, specify the part nos. in order from the 1st. station in the D side.  
When entry of part numbers becomes complicated, indicate on the manifold specification sheet.



## Plug-in Type: With Terminal Block

- Since lead wires of solenoid valve are connected with the terminals on upper surface of terminal block corresponding lead wires from power source can be wired at the bottom of terminal block.

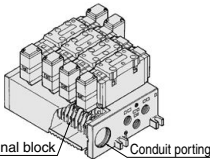

**VV5FR5-01T-061-04**

VFR5000 Series Manifold

Plug-in type with terminal block

Stations: 02 (2 stations), 10 (10 stations)

Port size: 04 (3/4), 06 (3/4), M (Mixed)

Thread type: Nil, Rc, F, G, N, NPT, T, NPTF

CE-compliant: Nil, Q (CE-compliant)

Symbol	Passage	Porting specifications (A, B)
1	Common	Common
2	Common	Common

\* For bottom ported: 1/2 only.

\* Semi-standard

## Plug-in Type: With Multi-connector (For wiring specifications, refer to page 1113.)

- Master connection of power and solenoid valves.
- Quick wiring permits ease of installation.

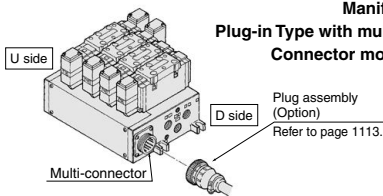

**VV5FR5-01CD-051-04**

VFR5000 Series Manifold

Plug-in Type with multi-connector

Connector mounting direction: D (D side mounting), U (U side mounting)

Stations: 02 (2 stations), 08 (8 stations)

Port size: 04 (3/4), 06 (3/4), M (Mixed)

Thread type: Nil, Rc, F, G, N, NPT, T, NPTF

CE-compliant: Nil, Q (CE-compliant)

Symbol	Passage	Porting specifications (A, B)
1	Common	Common
2	Common	Common

\* For bottom ported: 1/2 only.

\* Semi-standard

Note) Electrical entry and light/surge voltage suppressor for CE-compliant non plug-in type : D, DZ, F, FZ only.



## Plug-in Type: With D-sub Connector (For wiring specifications, refer to page 1113.)

- Wide range of interchangeability (D-sub connector (25P) conforming to MIL standard)
- Quick wiring permits easier installation.

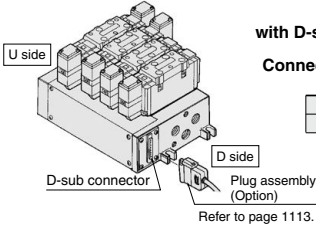

VV5FR5 - 01F D - 06 1 - 04

VFR5000 Series Manifold Plug-in type with D-sub connector

**Stations**

02	2 stations
⋮	⋮
08	* 8 stations

\* Max: 8 stations

**Connector mounting direction**

D	D side mounting
U	U side mounting

**Thread type**

Nll	Rc
F	G
N	NPT
T	NPTF

**CE-compliant**

Nll	—
Q	CE-compliant

Note) Electrical entry and light/surge voltage suppressor: F, FZ only.

**Symbol**

Symbol	Passage		Porting specifications (A, B)
	P	EA, EB	
1	Common	Common	Side
2			Bottom *

\* Semi-standard

**Port size**

Symbol	P, EA, EB	A, B *
04		1/2
06	3/4	3/4
M		Mixed

\* For bottom ported: 1/2 only.

Refer to page 1113.

## Non Plug-in Type: Grommet Terminal, DIN Terminal

- Wiring for every valve

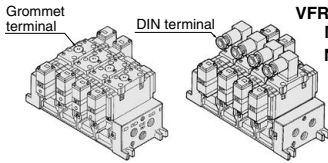

VV5FR5 - 10 - 05 1 - 04

VFR5000 Series Manifold Non plug-in type

**Stations**

02	2 stations
⋮	⋮
10	10 stations

**Thread type**

Nll	Rc
F	G
N	NPT
T	NPTF

**CE-compliant**

Nll	—
Q	CE-compliant

Note) Electrical entry and light/surge voltage suppressor: D, DZ only.

**Symbol**

Symbol	Passage		Porting specifications (A, B)
	P	EA, EB	
1	Common	Common	Side
2			Bottom *

\* Semi-standard

**Port size**

Symbol	P, EA, EB	A, B *
04		1/2
06	3/4	3/4
M		Mixed

\* For bottom ported: 1/2 only.

Note) Manifold base is common for the VFR5000 series. Terminal block is not required.

- SV
- SYJ
- SZ
- VF
- VP4
- VQ 1/2
- VQ 4/5
- VQC 1/2
- VQC 4/5
- VQZ
- SQ
- VFS
- VFR
- VQ7

# VFR5000 Series

## Manifold/Option Parts Assembly

### Individual SUP spacer

Supply port can be located at each valve individually after individual SUP spacer is mounted on manifold block.

Body type	Plug-in type	Non plug-in type
Part no.	VVFS5000-P-04-1	VVFS5000-P-04-2

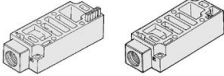

### Individual EXH spacer

Exhaust port can be located at each valve individually after individual EXH spacer is mounted on manifold block. (Common EXH type)

Body type	Plug-in type	Non plug-in type
Part no.	VVFS5000-R-04-1	VVFS5000-R-04-2

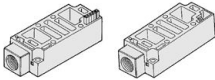

### SUP block disk

When 2 or more pressures (high and low) are supplied to one manifold, insert a disk between the stations which are supplied different pressures.

Body type	Plug-in type	Non plug-in type
Part no.	AXT628-12A	

### Throttle valve spacer

Mount interface speed control on manifold block. Cylinder speed can be controlled by metered out flow.

Body type	Plug-in type	Non plug-in type
Part no.	VVFS5000-20A-1	VVFS5000-20A-2

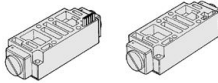

### Interface regulator

When interface regulator is mounted on manifold block, regulation to that valve is possible. (Refer to "Flow Rate Characteristics" on page 1111 before operation.)

Body type	Plug-in type	Non plug-in type
P port regulation	ARBF5050-00-P-1	ARBF5050-00-P-2
A port regulation	ARBF5050-00-A-1	ARBF5050-00-A-2
B port regulation	ARBF5050-00-B-1	ARBF5050-00-B-2

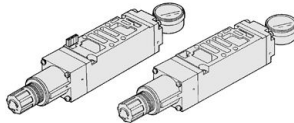

### Blanking plate

It is used by attaching on the manifold block for being prepared for removing a valve for maintenance reasons or planning to mount a spare valve, etc.

Body type	Plug-in type	Non plug-in type
Part no.	VVFS5000-10A	

## Manifold Option

### With exhaust cleaner Plug-in type/Non plug-in type

- High noise reduction effect: 35 dB or more
- Drainage and mist are collected (99.9% or more).
- Piping work is reduced.

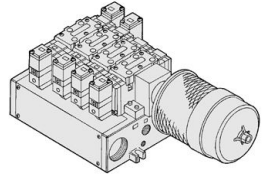

**For details, refer to page 1095.**



EXH block disk



SUP block disk

# 5 Port Pilot Operated Solenoid Valve Rubber Seal, Plug-in/Non Plug-in **VFR5000 Series**

## Manifold: Plug-in Type/Non Plug-in Type

### Plug-in type (With terminal block):

#### VV5FR5-01T-Station 1-Bore size

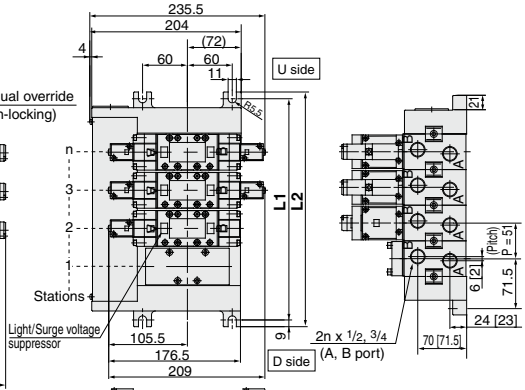
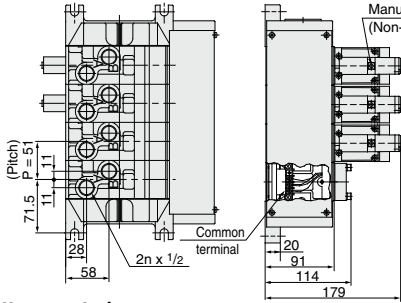

### Bottom ported:

#### VV5FR5-01T-Station 2-Bore size

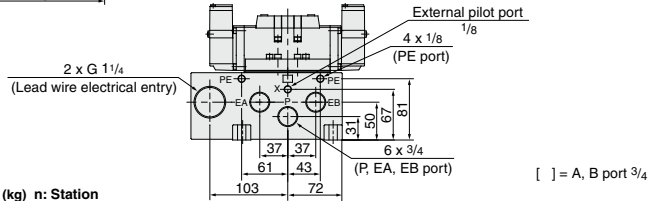

Formula for manifold weight  $M = 0.911n + 1.621$  (kg) n: Station

### Non plug-in type: VV5FR5-10-Station 1-Bore size

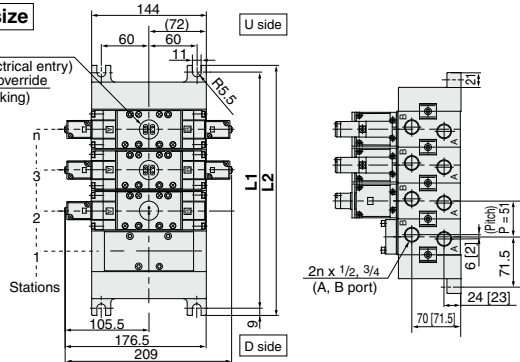
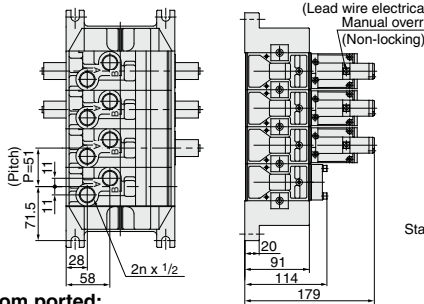

### Bottom ported:

#### VV5FR5-10-Station 2-Port size

##### DIN terminal

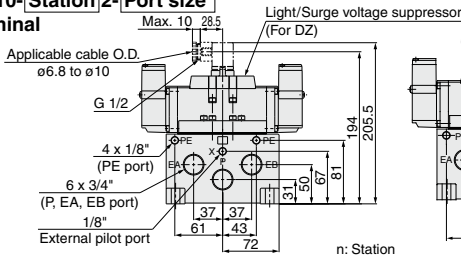

##### Grommet with terminal

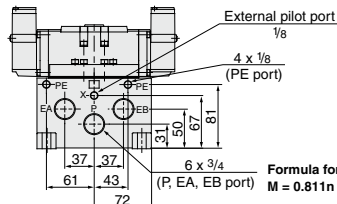

Formula for manifold weight  $M = 0.811n + 1.231$  (kg) n: Stations

Station	2	3	4	5	6	7	8	9	10	Formula
L <sub>1</sub>	194	245	296	347	398	449	500	551	602	$L_1 = 51 \times n + 92$
L <sub>2</sub>	212	263	314	365	416	467	518	569	620	$L_2 = 51 \times n + 110$

[ ] = A, B port 3/4

- SV
- SYJ
- SZ
- VF
- VP4
- VQ 1/2
- VQ 4/5
- VQC 1/2
- VQC 4/5
- VQZ
- SQ
- VFS
- VFR
- VQ7

# VFR5000 Series

## Manifold/Plug-in type: With Multi-connector/With D-sub connector

Plug-in type/With multi-connector: **VV5FR5-01CD** - Station 1 - Bore size, **VV5FR5-01CU** - Station 1 - Bore size

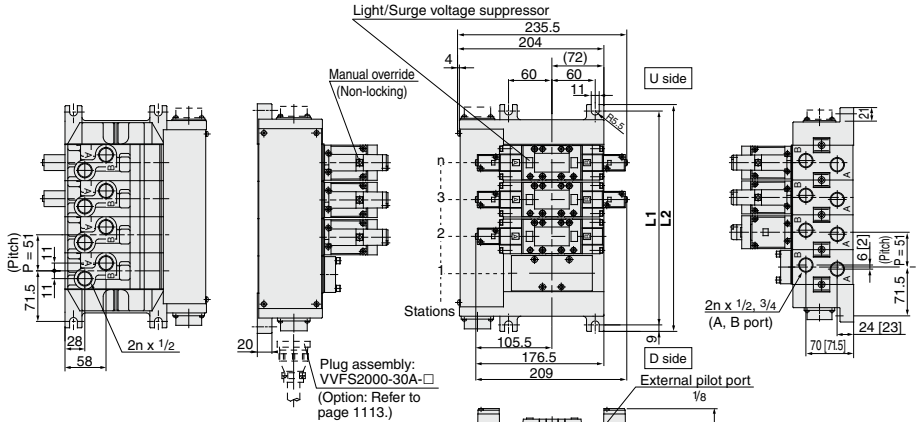

**Bottom ported:**  
**VV5FR5-01CD** - Station 2 - Bore size

Formula for manifold weight  $M = 0.916n + 1.709$  (kg) n: Stations  
\* For wiring specifications, refer to page 1113.

[ ] = A, B port 3/4

Plug-in type/With D-sub connector: **VV5FR5-01FD** - Station 1 - Bore size, **VV5FR5-01FU** - Station 1 - Bore size

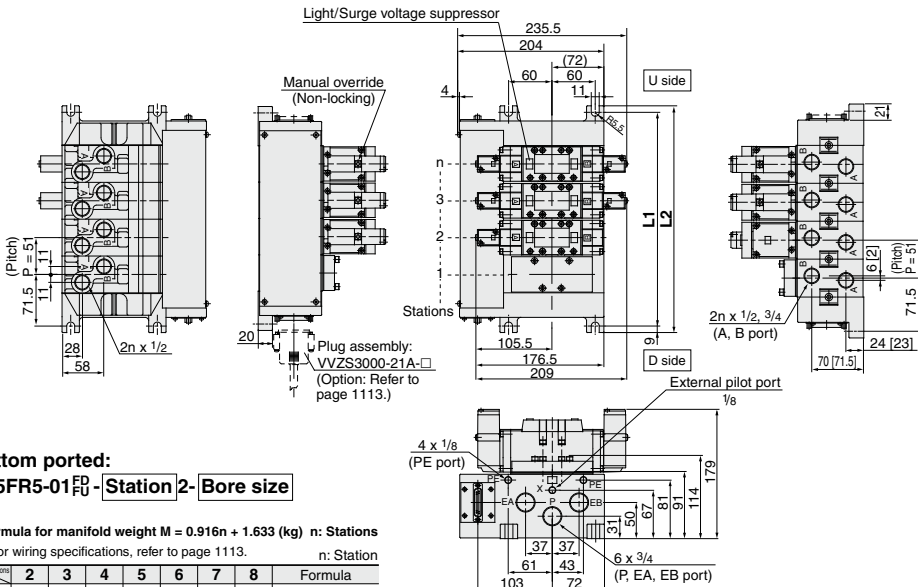

**Bottom ported:**  
**VV5FR5-01FD** - Station 2 - Bore size

Formula for manifold weight  $M = 0.916n + 1.633$  (kg) n: Stations  
\* For wiring specifications, refer to page 1113.

[ ] = A, B port 3/4

L	Station	2	3	4	5	6	7	8	Formula
L <sub>1</sub>		194	245	296	347	398	449	500	L <sub>1</sub> = 51 x n + 92
L <sub>2</sub>		212	263	314	365	416	467	518	L <sub>2</sub> = 51 x n + 110





## Manifold with Exhaust Cleaner

- Protection of work environment
- Reduction of valve exhaust noise of 35 dB or more
- Drainage and mist are collected. (99.9% or more)
- Piping work is reduced.

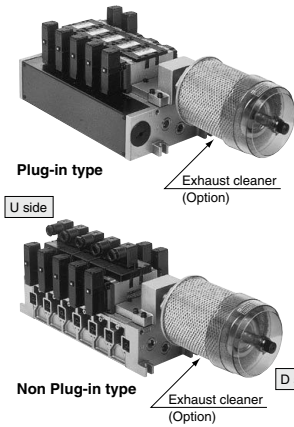

### Manifold Specifications

Manifold	Plug-in type: <b>VV5FR5-01□(-Q)</b>	Non plug-in type: <b>VV5FR5-10(-Q)</b>
Wiring	With terminal block With multi-connector With D-sub connector	DIN terminal Grommet terminal
Applicable valve model	VFR5□00-□F(-Q)	VFR5□10-□D(-Q), VFR5□10-□E
Porting specifications	Common SUP/Common EXH	
	A, B port	Side: 1/2, 3/4, Bottom: 1/2 (Option)
	P port	Side: 3/4 EXH: 1 1/2
Stations	2 to 10 <sup>(1)</sup>	
Applicable exhaust cleaners	AMC810-14 (Connecting port R 1 1/2) <sup>(2)</sup>	

Note 1) With multi connector, or with D-sub connector: 8 stations max.  
Note 2) Exhaust cleaner: Not attached.

Note) Electrical entry and light/surge voltage suppressor: D, DZ, F, FZ only



### How to Order

**VV5FR5 - 10 - 06 1 - 04 - CD -**

VFR5000 Series Manifold

**Base type/Electrical entry**

01T	Plug-in type With Terminal block
01C	Plug-in type with multi-connector
01F	Plug-in type with D-sub connector
10	Non plug-in type

**Connector mounting direction**

Symbol	With connector	Applicable base
Nll	None	01T, 10
D	D side mounting	01C, 01F
U	U side mounting	

**Stations**

02	2 stations
:	:
10	10 stations

**CE-compliant**

Nll	—
Q	CE-compliant

Note) Electrical entry and light/surge voltage suppressor: D, DZ, F, FZ only.

**Exhaust cleaner mounting direction**

Symbol	Exhaust cleaner mounting direction
CD	D side / D side mounting
CU	U side / U side mounting

**Thread type**

Symbol	P, EA, EB	A, B *	Nll	Rc
04		1/2	F	G
06	3/4	3/4	N	NPT
M		Mixed	T	NPTF

\* For bottom ported: 1/2 only.

**Port size**

**Symbol**

Symbol	Passage		Porting specifications (A, B)
1	P	EA, EB	Side
2	Common	Common	Bottom *

\* Semi-standard

- SV
- SYJ
- SZ
- VF
- VP4
- VQ 1/2
- VQ 4/5
- VQC 1/2
- VQC 4/5
- VQZ
- SQ
- VFS
- VFR
- VQ7

## How to Order Manifold Assembly

Instruct by specifying the valves and blanking plate to be mounted on the manifold along with the manifold base model no.

<Example> Plug-in type with terminal block: 6 stations

VV5FR5-01T-061-04-CD	1 set (Manifold part no.)
*VFR5100-5FZ	3 sets (2 position single part no.)
*VFR5200-5FZ	2 sets (2 position double part no.)
*VVF5000-10A	1 set (Blanking plate assembly part no.)
*AMC810-14	1 set (Exhaust cleaner part no.)

↳ The asterisk denotes the symbol for assembly. Prefix it to the part nos. of the solenoid valve, etc.

<Example> Non plug-in type: 6 stations

VV5FR5-10-061-04-CU	1 set (Manifold part no.)
*VFR5110-5E	3 sets (2 position single part no.)
*VFR5210-5E	2 sets (2 position double part no.)
*VVF5000-10A	1 set (Blanking plate assembly part no.)
*AMC810-14	1 set (Exhaust cleaner part no.)

↳ The asterisk denotes the symbol for assembly. Prefix it to the part nos. of the solenoid valve, etc.

Valve arrangement is counted from the D side.  
When ordering, specify the part nos. in order from the 1st. station in the D side.  
When entry of part numbers becomes complicated, indicate on the manifold specification sheet.

Valve arrangement is counted from the D side.  
When ordering, specify the part nos. in order from the 1st. station in the D side.  
When entry of part numbers becomes complicated, indicate on the manifold specification sheet.

## Caution

When using exhaust cleaner, mount it downwards.



# VFR5000 Series

## Manifold with Exhaust Cleaner: Plug-in Type/Non Plug-in Type

### Plug-in type: VV5FR5-01T- Station 1- Port size - $\frac{3}{4}$ "

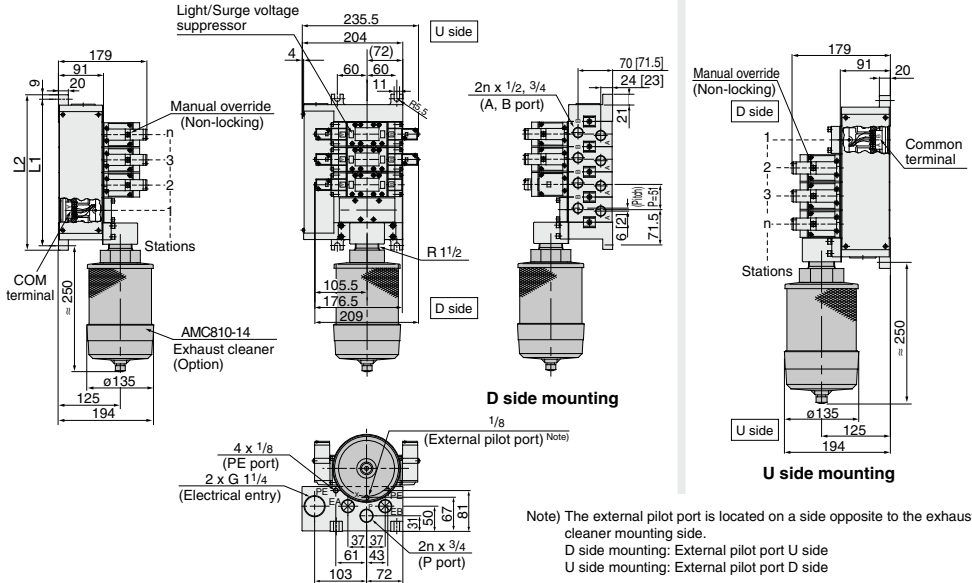

[ ] = A, B port  $\frac{3}{4}$ "

### Non plug-in type: VV5FR5-10- Station 1- Port size - $\frac{3}{4}$ "

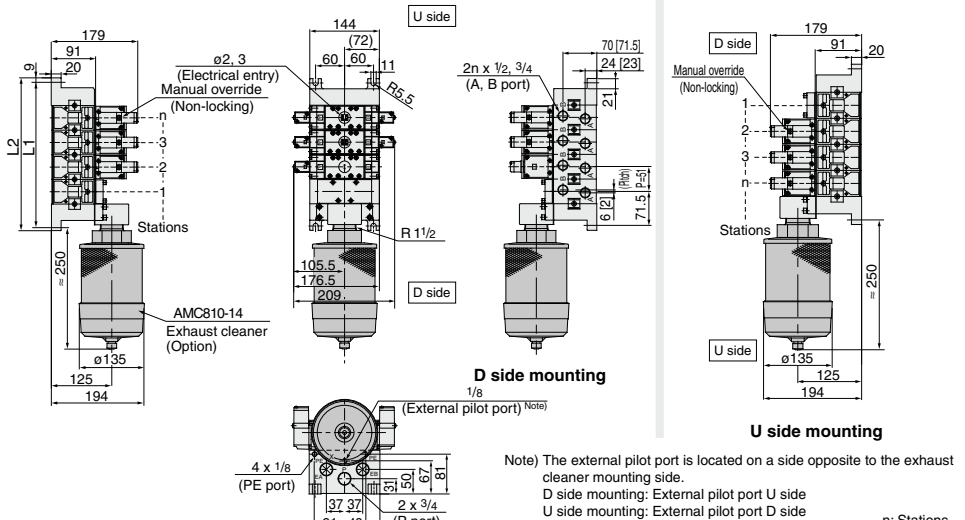

[ ] = A, B port  $\frac{3}{4}$ "

Station	2	3	4	5	6	7	8	9	10	Formula
L <sub>1</sub>	194	245	296	347	398	449	500	551	602	L <sub>1</sub> = 51 x n + 92
L <sub>2</sub>	212	263	314	365	416	467	518	569	620	L <sub>2</sub> = 51 x n + 110

**Manifold Option Parts Assembly/Plug-in Type, Non Plug-in Type**

**Individual SUP spacer**  
VVFS5000-P-04-1 (Plug-in type)  
VVFS5000-P-04-2 (Non plug-in type)

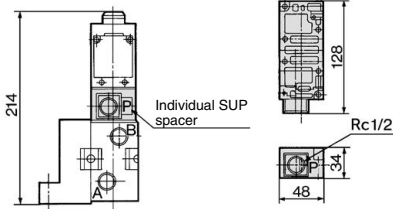

**Interface regulator/P port regulation**  
ARBF5050-00-P-1 (Plug-in type)  
ARBF5050-00-P-2 (Non plug-in type)

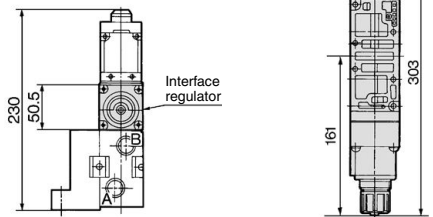

**Individual EXH spacer**  
VVFS5000-R-04-1 (Plug-in type)  
VVFS5000-R-04-2 (Non plug-in type)

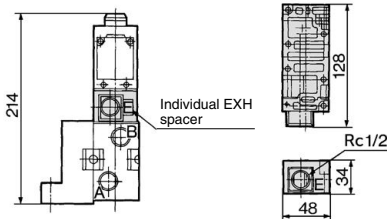

**Interface regulator/A port regulation**  
ARBF5050-00-A-1 (Plug-in type)  
ARBF5050-00-A-2 (Non plug-in type)

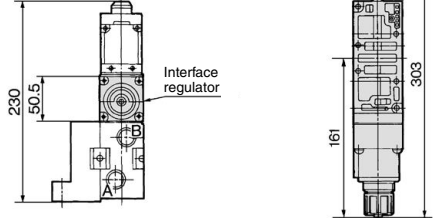

**SUP block disk: AXT628-12A**  
**EXH block disk: AXT512-14-1A**

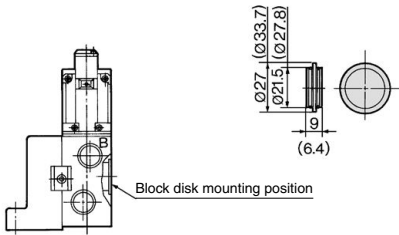

( ) : SUP block disk

**Interface regulator/B port regulation**  
ARBF5050-00-B-1 (Plug-in type)  
ARBF5050-00-B-2 (Non plug-in type)

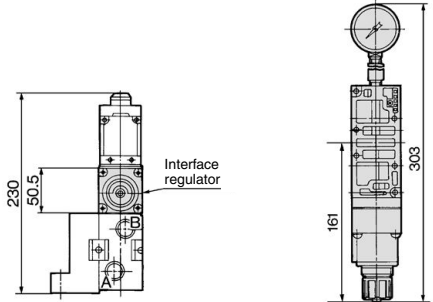

**Throttle valve spacer**  
VVFS5000-20A-1 (Plug-in type)  
VVFS5000-20A-2 (Non plug-in type)

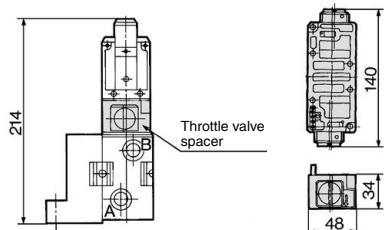

SV
SYJ
SZ
VF
VP4
VQ 1/2
VQ 4/5
VQC 1/2
VQC 4/5
VQZ
SQ
VFS
<b>VFR</b>
VQ7

# VFR5000 Series

## Manifold Base Construction: Plug-in Type/Non Plug-in Type

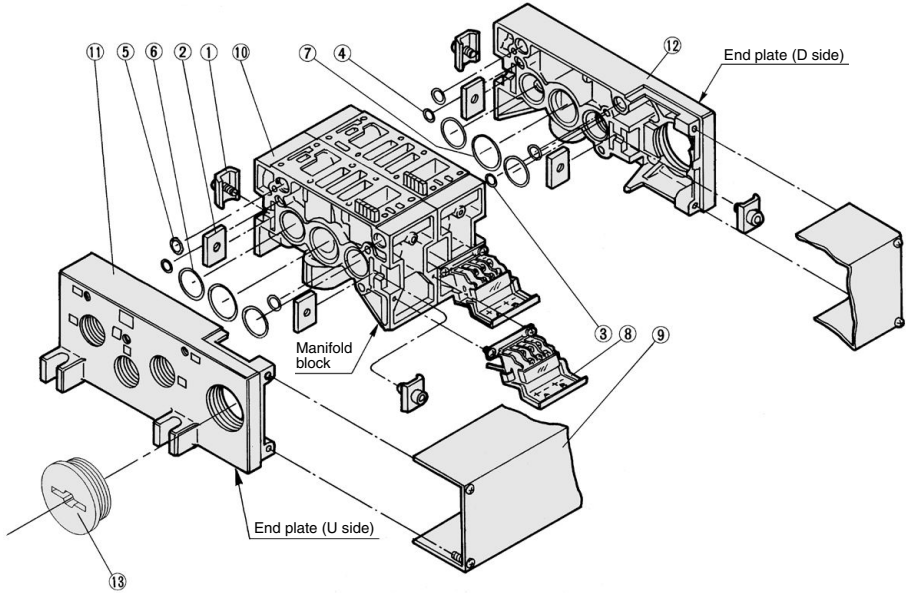

### Replacement Parts

No.	Description	Material	Part no.
1	Connection fitting A	Steel plate	AXT628-6-1A
2	Connection fitting B	Steel plate	AXT628-6-2
3	O-ring	NBR	KA00078
4	O-ring	NBR	KA00495
5	O-ring	NBR	KA00328M
6	O-ring	NBR	KA00523M
7	O-ring	NBR	KA01587M
8	Terminal block assembly	—	VFR5000-21-1A
9	Junction cover assembly	For 01T	VVFS5000-4A- <sup>[Stations]</sup>
13	Rubber plug	NBR	AXT336-9

- When requiring replacement manifold stations, order replacement parts assembly no. 10: manifold block assembly part.
- For plug-in type: The manifold base with terminal stand (integrated with a junction cover) is required with the 9 junction cover assembly.

### Replacement Parts: Sub Assembly

Note) Manifold Base/Construction: Plug-in type with terminal block.

No.	Description	Assembly part no.	Component parts	Applicable manifold base
10	Manifold block assembly	VFR5000-20-1A- <sup>04</sup> <sub>06</sub>	Manifold block 10, Metal joint 1, 2, Terminal block 8, O-ring 3, 4, 5, 6, 7, Receptacle assembly	Plug-in type
		VVFS5000-1A-2- <sup>04</sup> <sub>06</sub>	Manifold block 10, Metal joint 1, 2, O-ring 3, 4, 5, 6, 7	Non plug-in type
11	End plate (U side) assembly	VVFS5000-2A-1	End plate (U) 11, Metal joint 1, 2	Plug-in type
		VVFS5000-2A-2	End plate (U) 11, Metal joint 1, 2	Non plug-in type
12	End plate (D side) assembly	VVFS5000-3A-1	End plate (D) 12, Metal joint 1, 2, O-ring 3, 4, 5, 6, 7	Plug-in type
		VVFS5000-3A-2	End plate (D) 12, Metal joint 1, 2, O-ring 3, 4, 5, 6, 7	Non plug-in type

\* Contact SMC for CE-compliant products.

# 5 Port Pilot Operated Solenoid Valve Rubber Seal, Plug-in/Non Plug-in VFR6000 Series



## Standard Specifications



Plug-in type



Non plug-in type

Valve specifications	Fluid		Air
	Operating pressure range	2 position single/3 position 2 position double	0.2 to 0.9 MPa 0.1 to 0.9 MPa
Ambient and fluid temperature	-10 to 50°C (No freezing.)		
Lubrication	Non-lube <sup>(1)</sup>		
Manual override	Non-locking push type		
Impact/Vibration resistance	300/50m/s <sup>2</sup> <sup>(2)</sup>		
Enclosure	Dustproof		
Electricity specifications	Coil rated voltage		100, 200 VAC (50/60 Hz), 24 VDC
	Allowable voltage fluctuation		-15 to -10% of rated voltage
	Apparent power (AC) <sup>(3)</sup>	Inrush	5.6 VA/50 Hz, 5.0 VA/60 Hz
		Holding	3.4 VA/50 Hz, 2.3 VA/60 Hz
	Power consumption (DC) <sup>(3)</sup>		1.8 W (2.04 W: With light/surge voltage suppressor)
Electrical entry	Plug-in type	Conduit terminal	
	Non plug-in type	Grommet terminal, DIN terminal	

Note 1) Use turbine oil Class 1 (ISO VG32), if lubricated. Note 3) At rated voltage.  
 Note 2) Impact resistance: No malfunction occurred when it is tested with a drop tester in the axial direction and at the right angles to the main valve and armature in both energized and de-energized states every once for each condition. (Values at the initial period)  
 Vibration resistance: No malfunction occurred in a one-sweep test between 45 and 2000 Hz. Test was performed at both energized and de-energized states in the axial direction and at the right angles to the main valve and armature. (Values at the initial period)

## Option Specifications

Main valve manual override	Direct manual override
Coil rated voltage	110 to 120, 220, 240 VAC 50/60 Hz 12 VDC
Option	With light/surge voltage suppressor

## Symbol

2 position	3 position
Single	Closed center
Double	Exhaust center
	Pressure center

## Caution

When double solenoid is used, spool valve should be mounted horizontally.  
 If there are vibrations, spool valve should be mounted perpendicular to the vibration direction.

## Model

Type of actuation	Model		Port size	Flow rate characteristics <sup>(1)</sup>						Max. operating cycle (Hz) <sup>(2)</sup>	Response time (ms) <sup>(3)</sup>	Weight (kg) <sup>(4)</sup>
	Plug-in	Non plug-in		1 → 4/2 (P → A/B)	4/2 → 5/3 (A/B → EA/EB)	C <sub>v</sub> [dm <sup>3</sup> /s]	b	C <sub>v</sub> [dm <sup>3</sup> /s]	b			
2 position	Single	VFR610 □ VFR611 □	3/4	40	0.12	9.1	41	0.15	9.6	2	100 or less	4.73 (4.56)
	Double	VFR620 □ VFR621 □	3/4	40	0.14	9.2	41	0.17	9.7	2	100 or less	4.78 (4.61)
3 position	Closed center	VFR630 □ VFR631 □	3/4	39	0.17	9.3	39	0.15	9.3	1	150 or less	4.72 (4.55)
	Exhaust center	VFR640 □ VFR641 □	3/4	38	0.14	8.9	42 [40]	0.12 [0.15]	9.6 [9.4]	1	150 or less	4.72 (4.55)
	Pressure center	VFR650 □ VFR651 □	3/4	38 [20]	0.10 [0.44]	8.7 [5.7]	40	0.16	9.3	1	150 or less	4.72 (4.55)

Type of actuation	Model		Port size	Effective area (mm <sup>2</sup> )
	Plug-in	Non plug-in		
2 position	Single	VFR610 □ VFR611 □	1	191
	Double	VFR620 □ VFR621 □	1	191
3 position	Closed center	VFR630 □ VFR631 □	1	180
	Exhaust center	VFR640 □ VFR641 □	1	P → A, B: 178 A, B → EA, EB: 212 Normal position: 193
	Pressure center	VFR650 □ VFR651 □	1	P → A, B: 183 Normal position: 82 A, B → EA, EB: 199

Note 1) [ ] : Denotes the normal position.  
 Note 2) Min. operating frequency is once in 30 days.  
 Note 3) Based on dynamic performance test, JIS B 8419: 2010. (Coil temperature: 20°C, at rated voltage, without surge voltage suppressor)  
 Note 4) For VFR6□0□□FZ-06, ( ): VFR6□10□□DZ-06



Note) Electrical entry and light/surge voltage suppressor: D, DZ, F, FZ only.



## How to Order

**Electrical entry**

F: Plug-in type, conduit type

CE-compliant

**Option**

Nil	None
Z	With light/surge voltage suppressor

**Port size**

Nil	Without sub-plate
06	3/4
10	1

**Plug-in** VFR6 0 0 - 5 F - 10 -   -  

**Non plug-in** VFR6 1 1 - 1 D - 10 -   -

**Symbol**

1	2 position single (A)4 2(B) (EA)5 1 3(EB) (P)
2	2 position double (A)4 2(B) (EA)5 1 3(EB) (P)
3	3 position closed center (A)4 2(B) (EA)5 1 3(EB) (P)
4	3 position exhaust center (A)4 2(B) (EA)5 1 3(EB) (P)
5	3 position pressure center (A)4 2(B) (EA)5 1 3(EB) (P)

**Body option**

0	Standard
1*	Direct manual override

\* Semi-standard

**Coil rated voltage**

1	100 VAC, 50/60 Hz
2	200 VAC, 50/60 Hz
3	110 to 120 VAC, 50/60 Hz
4	220 VAC, 50/60 Hz
5	24 VDC
6	12 VDC
7	240 VAC, 50/60 Hz

Note) Electrical entry: D, F only.  
For other rated voltages, please consult with SMC.

**CE-compliant**

Nil	—
Q	CE-compliant (Note)

Note) Electrical entry and light/surge voltage suppressor: D, DZ, F, FZ only.

**Thread type**

Nil	Rc
F	G
N	NPT
T	NPTF

**Electrical entry**

E: Grommet terminal	D: DIN terminal
---------------------	-----------------

CE-compliant

## How to Order Pilot Valve Assembly

SF4 - 1 F - 22 -  

**Coil rated voltage**

Symbol	Rated voltage
1	100 VAC, 50/60 Hz
2	200 VAC, 50/60 Hz
3*	110 to 120 VAC, 50/60 Hz
4*	220 VAC, 50/60 Hz
5	24 VDC
6*	12 VDC
7*	240 VAC, 50/60 Hz

\* Semi-standard  
For other rated voltages, please consult with SMC.

**CE-compliant**

Nil	—
Q	CE-compliant

# 5 Port Pilot Operated Solenoid Valve Rubber Seal, Plug-in/Non Plug-in **VFR6000 Series**

Use as a guide for selection.  
Please confirm the actual conditions with SMC  
Sizing Program.

## Cylinder Speed Chart

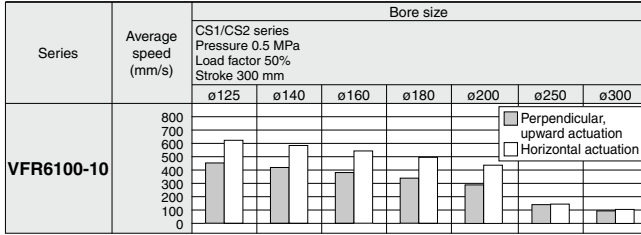

- \* It is when the cylinder is extending that is meter-out controlled by speed controller which is directly connected with cylinder, and its needle valve with being fully open.
- \* The average velocity of the cylinder is what the stroke is divided by the total stroke time.
- \* Load factor: ((Load mass x 9.8)/Theoretical force) x 100%

## Conditions

		CS1/CS2 series
VFR6110-10	Tube x Length	SGP25A x 1 m
	Speed controller	AS600-10
	Silencer	AN600-10

## How to Order Sub-plate Assembly

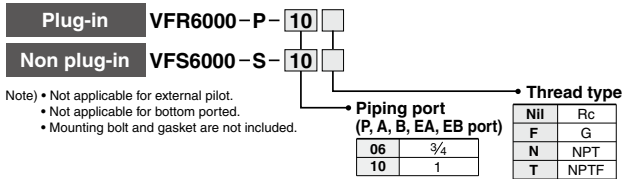

- Note) • Not applicable for external pilot.  
 • Not applicable for bottom ported.  
 • Mounting bolt and gasket are not included.

- SV
- SYJ
- SZ
- VF
- VP4
- VQ 1/2
- VQ 4/5
- VQC 1/2
- VQC 4/5
- VQZ
- SQ
- VFS
- VFR
- VQ7

# VFR6000 Series

## Construction

### 2 position single

VFR61□0

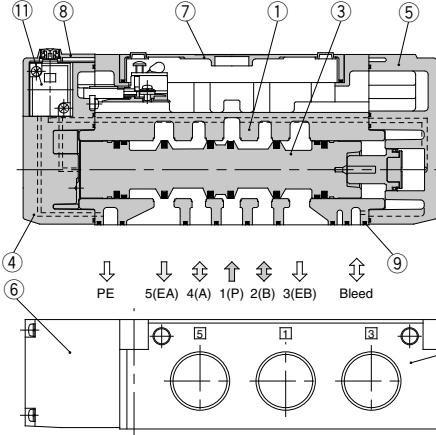
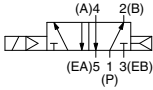

### 2 position double

VFR62□0

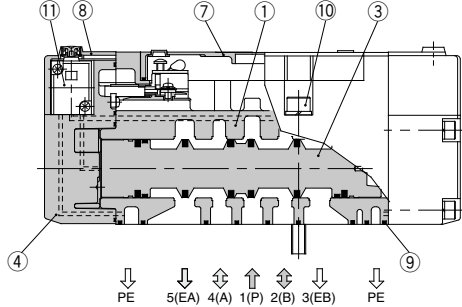
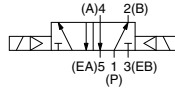

### 3 position closed center/exhaust center/pressure center

Closed center: VFR63□0

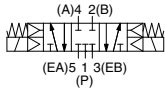

Exhaust center: VFR64□0

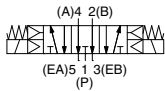

Pressure center: VFR65□0

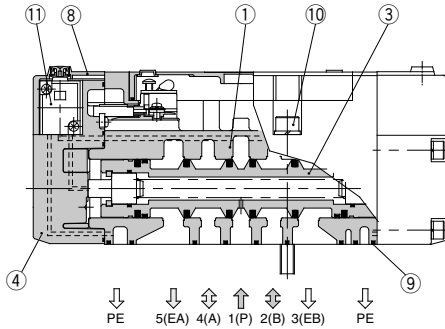
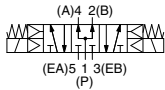

This figure shows a closed center type.

### Component Parts

No.	Description	Material	Note
1	Body	Aluminum die-casted	Platinum silver
2	Sub-plate	Aluminum die-casted	Platinum silver
3	Spool valve	Aluminum, NBR	
4	Adapter plate	Aluminum die-casted	Black

### Component Parts

No.	Description	Material	Note
5	End plate	Aluminum die-casted	Black
6	Junction cover	Resin	Black
7	Light cover	Resin	
8	Pilot valve cover	Resin	Black

### Replacement Parts

No.	Description	Material	Part no.		
			VFR61□□	VFR62□□	VFR63□□/64□□/65□□
9	Gasket	NBR	VFS6000-15	VFS6000-15	VFS6000-15
10	Hexagon socket head screw <small>(Note)</small>	Steel	CA00160C	CA00160C	CA00160C
	M8 spring washer <small>(Note)</small>	Steel	EC00014	EC00014	EC00014
11	Pilot valve assembly	—	Refer to "How to Order Pilot Valve Assembly" on page 1100.		

Note) For the VFR6000 series, it requires 4 pcs.



5 Port Pilot Operated Solenoid Valve  
 Rubber Seal, Plug-in/Non Plug-in **VFR6000 Series**

**Plug-in: 2 Position Single/Double, 3 Position Closed Center/Exhaust Center/Pressure Center**

**2 position single: VFR610<sup>0</sup>-□F(Z)**

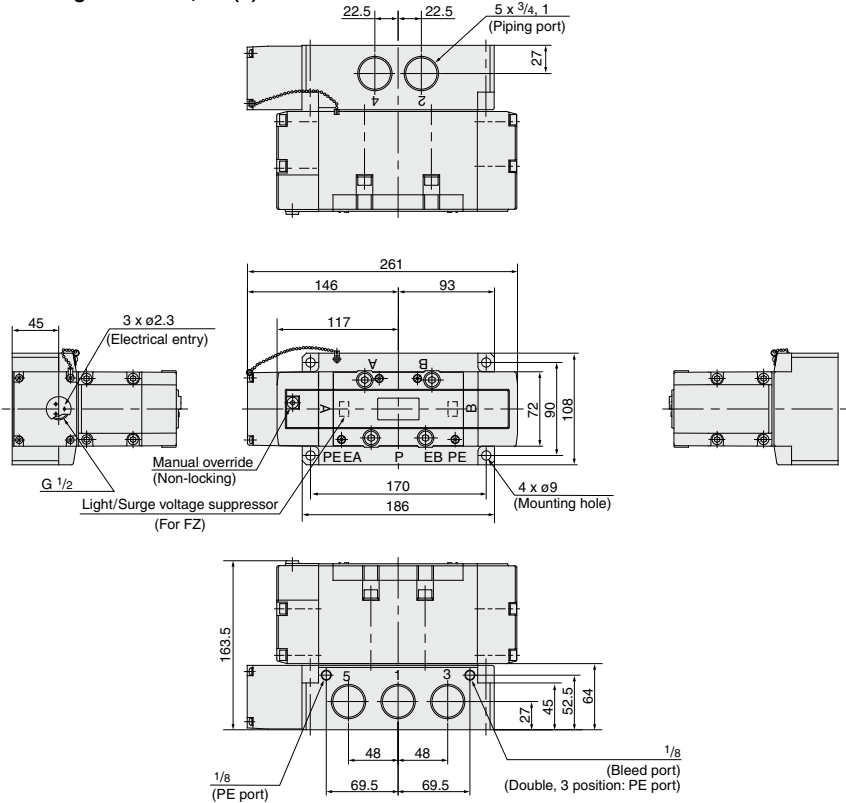

SV
SYJ
SZ
VF
VP4
VQ 1/2
VQ 4/5
VQC 1/2
VQC 4/5
VQZ
SQ
VFS
<b>VFR</b>
VQ7

**2 position double: VFR620<sup>0</sup>-□F(Z)**

**3 position closed center: VFR630<sup>0</sup>-□F(Z)**

**3 position exhaust center: VFR640<sup>0</sup>-□F(Z)**

**3 position pressure center: VFR650<sup>0</sup>-□F(Z)**

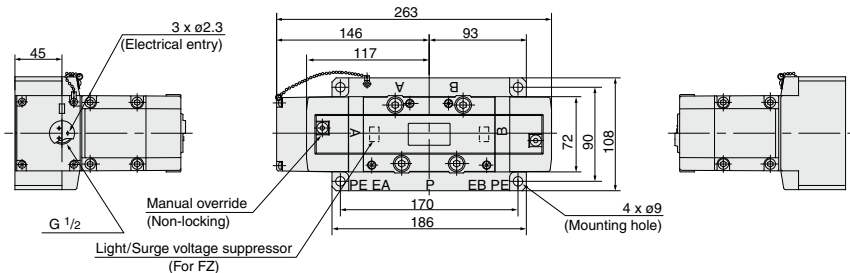

\* Other dimensions are the same as the single type.



# VFR6000 Series

## Non Plug-in: 2 Position Single/Double, 3 Position Closed Center/Exhaust Center/Pressure Center

2 position single: VFR611<sup>0</sup>-□E, VFR611<sup>0</sup>-□D(Z)

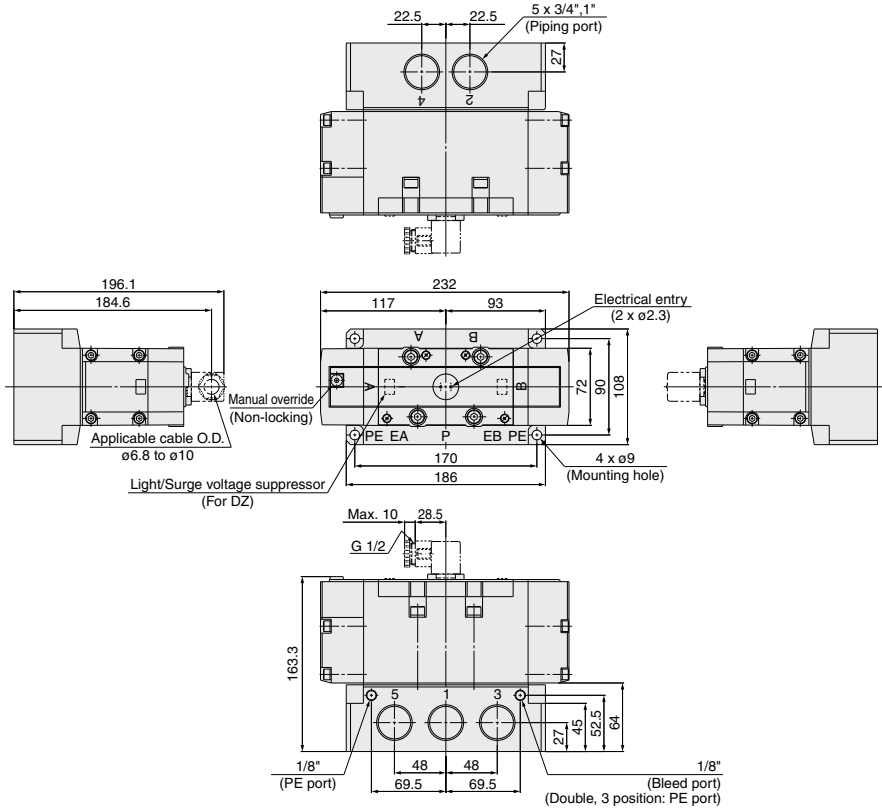

2 position double: VFR621<sup>0</sup>-□E, VFR621<sup>0</sup>-□D(Z) 3 position closed center: VFR631<sup>0</sup>-□E, VFR631<sup>0</sup>-□D(Z)  
 3 position exhaust center: VFR641<sup>0</sup>-□E, VFR641<sup>0</sup>-□D(Z)  
 3 position pressure center: VFR651<sup>0</sup>-□E, VFR651<sup>0</sup>-□D(Z)

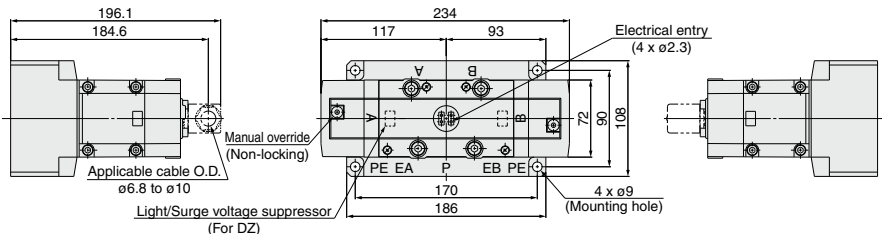

\* Other dimensions are the same as the single type.

# 5 Port Pilot Operated Solenoid Valve Rubber Seal, Non Plug-in **VFR2000 Series**



Non plug-in type

## How to Order

Non plug-in



**30 - VFR2 1 10 [ ] - 1 D [ ] [ ] - [ ] 02 [ ]**

Conforming to CSA standard

### Symbol

1	2 position single (A)4 2(B) (EA)5 1 3(EB) (P)
2	2 position double (A)4 2(B) (EA)5 1 3(EB) (P)
3	3 position closed center (A)4 2(B) (EA)5 1 3(EB) (P)
4	3 position exhaust center (A)4 2(B) (EA)5 1 3(EB) (P)
5	3 position pressure center (A)4 2(B) (EA)5 1 3(EB) (P)

### Pilot type

Nil	Internal pilot
R *	External pilot

\* Option (External pilot is available only on sub-plate type.)

### Coil rated voltage

1	100 VAC, 50/60 Hz
2	200 VAC, 50/60 Hz
3 *	110 to 120 VAC, 50/60 Hz
4 *	220 VAC, 50/60 Hz
5	24 VDC
6 *	12 VDC
7 *	240 VAC, 50/60 Hz

\* Semi-standard

### Piping (P, A, B, EA, EB port)

Nil	Side ported
-----	-------------

\* Semi-standard

### Port size (P, A, B port)

Nil	Without sub-plate
01	1/8
02	1/4

EA, EB port: 1/8

### Thread type

Nil	Rc
N	NPT
T	NPTF
F	G

### Pilot valve manual override

Nil: Non-locking push type      B\*: Locking type B (Tool required)



A\*: Non-locking push type A (Extended)      C\*: Locking type C (Lever)



\* Semi-standard

### Option

Nil	None
Z	With light/surge voltage suppressor

### Electrical entry

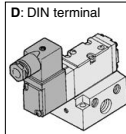

Refer to the standard product for product specifications, dimensions and model selection procedures.

- SV
- SYJ
- SZ
- VF
- VP4
- VQ 1/2
- VQ 4/5
- VQC 1/2
- VQC 4/5
- VQZ
- SQ
- VFS
- VFR
- VQ7

# 5 Port Pilot Operated Solenoid Valve Rubber Seal, Non Plug-in **VFR3000 Series**



## How to Order

**Non plug-in** **30 - VFR3** **1** **4** **0** **-** **1** **D** **-** **02** **Individual electrical entry**

**Conforming to CSA standard**

**Symbol**

1	2 position single (A)4 2(B) (EA)5 1 3(EB) (P)
2	2 position double (A)4 2(B) (EA)5 1 3(EB) (P)
3	3 position closed center (A)4 2(B) (EA)5 1 3(EB) (P)
4	3 position exhaust center (A)4 2(B) (EA)5 1 3(EB) (P)
5	3 position pressure center (A)4 2(B) (EA)5 1 3(EB) (P)

**Body option**

0	Standard
---	----------

**Pilot type**

NII	Internal pilot
R *	External pilot

\* Semi-standard

**Coil rated voltage**

1	100 VAC, 50/60 Hz
2	200 VAC, 50/60 Hz
3 *	110 to 120 VAC, 50/60 Hz
4 *	220 VAC, 50/60 Hz
5	24 VDC
6 *	12 VDC
7 *	240 VAC, 50/60 Hz

\* Semi-standard

**Piping (P, A, B, EA, EB port)**

NII	Side ported
B *	Bottom ported

\* Semi-standard

**Port size (P, A, B, EA, EB port)**

NII	Without sub-plate
02	1/4
03	3/8

\* For bottom ported: 1/4

**Thread type**

NII	Rc
N	NPT
T	NPTF
F	G

**Pilot valve manual override**

NII: Non-locking push type	B*: Locking type B (Tool required)
A*: Non-locking push type A (Extended)	C*: Locking type C (Lever)

\* Semi-standard

**Option**

NII	None
Z	With light/surge voltage suppressor

**Electrical entry**

D: DIN terminal

Refer to the standard product for product specifications, dimensions and model selection procedures.

# 5 Port Pilot Operated Solenoid Valve Rubber Seal, Non Plug-in **VFR4000 Series**



## How to Order

**Non plug-in** **30 - VFR4** **4 0** **- 1 D** **03** **Individual electrical entry**

Conforming to CSA standard

**Symbol**

1	2 position single (A)4 2(B) (EA)5 1 3(EB) (P)
2	2 position double (A)4 2(B) (EA)5 1 3(EB) (P)
3	3 position closed center (A)4 2(B) (EA)5 1 3(EB) (P)
4	3 position exhaust center (A)4 2(B) (EA)5 1 3(EB) (P)
5	3 position pressure center (A)4 2(B) (EA)5 1 3(EB) (P)

**Pilot type**

Nil	Internal pilot
R *	External pilot

\* Semi-standard

**Coil rated voltage**

1	100 VAC, 50/60 Hz
2	200 VAC, 50/60 Hz
3 *	110 to 120 VAC, 50/60 Hz
4 *	220 VAC, 50/60 Hz
5	24 VDC
6 *	12 VDC
7 *	240 VAC, 50/60 Hz

\* Semi-standard

**Piping (P, A, B, EA, EB port)**

Nil	Side ported
B *	Bottom ported

\* Semi-standard : Bottom ported is not available for external pilot.

**Port size (P, A, B port)**

Nil	Without sub-plate
03	3/8
04 *	1/2

EA, EB port: 3/8

**Thread type**

Nil	Rc
N	NPT
T	NPTF
F	G

**Pilot valve manual override**

Nil: Non-locking push type	B*: Locking type B (Tool required)
A*: Non-locking push type A (Extended)	C*: Locking type C (Lever)

\* Semi-standard

**Option**

Nil	None
Z	With light/surge voltage suppressor

**Electrical entry**

D: DIN terminal

Refer to the standard product for product specifications, dimensions and model selection procedures.

- SV
- SYJ
- SZ
- VF
- VP4
- VQ 1/2
- VQ 4/5
- VQC 1/2
- VQC 4/5
- VQZ
- SQ
- VFS
- VFR
- VQ7





# VFR2000/3000/4000/5000/6000 Series Specific Product Precautions 1

Be sure to read this before handling the products. Refer to back page 50 for Safety Instructions and pages 3 to 9 for 3/4/5 Port Solenoid Valve Precautions.

## ⚠ Caution

### Plug-in type (With terminal block)

#### VFR2000/3000/4000 Series

- If you remove the junction cover ① on the sub-plate, you will see the plug-in terminal block ② attached to the inside of sub-plate.

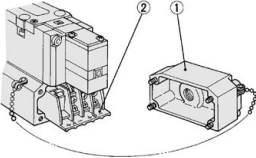

- The following markings are on the terminal block. Connect with corresponding power side.

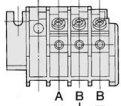

... B side solenoid  
... Common (COM) terminal  
... A side solenoid

- Although "A-", "B+" and "B-" marks are indicated on the terminal block, this can be used as either "+COM" or "-COM".
- Applicable terminal:  
VFR2000, VFR3000: 1.25-3, 1.25-3S, 1.25Y-3N, 1.25Y-3S  
VFR4000: 1.25-3.5M, 1.25Y-3L, 1.25Y-3M

#### VFR5000 Series

- Remove junction cover for sub-plate ①, depress levers ③ of terminal block assembly ②, pull out terminal block assembly.

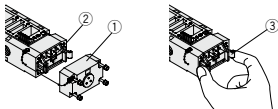

- Terminal block assembly is marked as below. Connect it to power supply side.

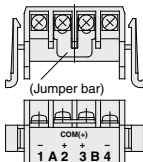

Model	Terminal block marking	A- (1)	B+ (3)	B- (4)
VFR510□		A side	COM	
VFR520□		A side	COM	B side
VFR540□		A side	COM	B side

### Lead Wire Connection

- Terminal block assembly can be used as "+" and "-" common regardless of markings. Do not remove jumper bar because it is used for common connection.
- Applicable terminal:  
1.25-4, 1.25-4M

#### VFR6000 Series

- If you remove the junction cover ① on the sub-plate, you will see the plug-in terminal block ② attached to the inside of sub-plate.

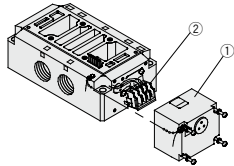

- Terminal block assembly is wired like the following figure. Connect it to each power supply side.

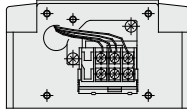

Model	Position	Left		
		Center	Right	
VFR610□		A side	COM	
VFR620□		A side	COM	B side
VFR640□		A side	COM	B side

- Can be used as either "+COM" or "-COM".
- Applicable terminal:  
1.25-4, 1.25-4M

#### Non plug-in type

##### VFR3000/4000 Series (VFR3□40/4□40)

- Type G: Lead wire comes directly from the solenoid part. Connect it with the power source. Grommet with DC voltage surge voltage suppressor has polarity. Connect red lead wire to + (positive) side and black to - (negative) side.

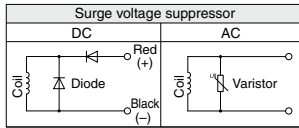

- Type E, T, D, Y: In the case of DIN terminal block and terminal block, there is no polarity of positive (+) and negative (-). Connect no. 1 and no. 2 terminals with corresponding power side.

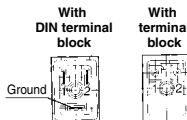

- Applicable cable O.D.  
Type T:  $\phi 6$  to  $\phi 8$  mm  
Type E:  $\phi 2.3$  to  $\phi 2.8$  mm  
Type D (VFR2000 series):  $\phi 6$  to  $\phi 8$  mm  
Type D (VFR3000/4000 series):  $\phi 4.5$  to  $\phi 7$  mm  
Type Y:  $\phi 4.5$  to  $\phi 7$  mm
- Applicable crimp terminal  
Type E, T: 1.25-3, 1.25-3S, 1.25Y-3N, 1.25Y-3S (Round shape or Y shape crimp terminal cannot be used for Type D.)

#### VFR3000/4000/5000/6000 Series

##### (VFR3□10/4□10)

##### DIN terminal block type

- Male pin terminal of DIN terminal block of solenoid valves are wired as shown below. Connect to corresponding terminal on the connector.



Terminal no.	Internal wiring
1	SOL. A side
2	SOL. B side
3	COM
	Ground

- Can be used as either "+COM" or "-COM".
- Applicable cable  
Cross section of the wire: 0.5 to 1.5 mm<sup>2</sup>  
Cable O.D.:  $\phi 8$  to  $\phi 10$
- Applicable crimp terminal shown below.

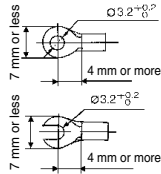

Corresponding to R1.25-3 of JIS C 2805

J.S.T. Mfg. Co., Ltd.  
Equivalent to R1.25-3

- Proper tightening torque of the connector  
Connector set screw 0.5 to 0.6 N·m  
Terminal screw 0.5 to 0.6 N·m
- Incorrect connection of "COM terminal" (DIN terminal no. 3) can cause damage on power source circuit.

##### Terminal block type

- Remove cover ①, over terminal block ② attached to the inside of body. Connect with corresponding power side. For a type with light and surge voltage suppressor, straightly pull out the light and surge voltage suppressor substrate ③ and then connect them.

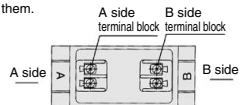
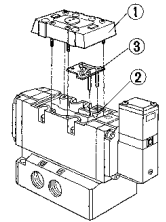

- Applicable terminal:  
VFR3000: 1.25-3, 1.25-3S, 1.25Y-3N, 1.25Y-3S  
VFR4000: 1.25-3.5M, 1.25Y-3L, 1.25Y-3M  
VFR5000/6000: 1.25-3.5M, 1.25-3L, 1.25-3M



# VFR2000/3000/4000/5000/6000 Series Specific Product Precautions 2

Be sure to read this before handling the products. Refer to back page 50 for Safety Instructions and pages 3 to 9 for 3/4/5 Port Solenoid Valve Precautions.

## ⚠ Caution

### Attaching and Detaching Connectors

- To attach a connector, hold the lever and connector unit between your fingers and insert straight onto the pins of the solenoid valve so that the lever's pawl is pushed into the groove and locks.
- To detach a connector, remove the pawl from the groove by pushing the lever downward with your thumb, and pull the connector straight out.

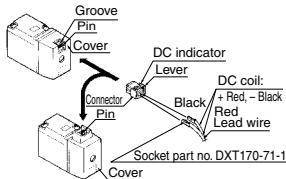

### Attaching and Detaching Lead Wires with Sockets

Peel 3.2 to 3.7 mm of the tip of lead wire, enter the core wires neatly into a socket and crimp it with a special crimp tool. Be careful so that the cover of lead wire does not enter into the crimping part.

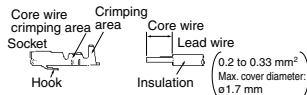

### Attaching and Detaching Lead Wires with Sockets

- Attaching**  
Insert the sockets into the square holes of the connector (with + and - indication) and, continue to push the sockets all the way in until the lock by hooking into the seats in the connector. (When they are pushed in, their hooks open and they are locked automatically.) Then confirm that they are locked by pulling lightly on the lead wires.

- Detaching**  
To detach a socket from a connector, pull out the lead wire while pressing the socket's hook with a stick having a thin tip (approx. 1 mm). If the socket will be used again, first spread the hook outward.

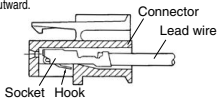

### Plug Connector Lead Wire Length

Standard length is 300 mm, but the following lengths are also available.

#### How to Order Connector Assembly

**DXT170-80-□ A-□**

#### Lead wire color

Symbol	Lead wire with socket	Note
Nil	Sockets (2 pcs.) only	Without lead wire
1	Blue (2 pcs.)	For 100 VAC
2	Red (2 pcs.)	For 200 VAC
3	Gray (2 pcs.)	Other VAC
4	Red + Black: -	For DC

#### Lead wire length

Symbol	Lead wire length (L mm)
Nil	300
6	600
10	1000
15	1500
20	2000
25	2500
30	3000

#### How to Order

Include the connector assembly part number together with the part number for the plug connector's solenoid valve without a connector.  
<Example> For lead wire length 2000 mm  
VFR2210-5M0-02 ..... 3 pcs.  
DXT170-80-4A-20 ..... 6 pcs.

### Light/Surge Voltage Suppressor

Refer to table 1 for "VFR2000 Series Plug-in type", "VFR3□□0, VFR4□□0 type of VFR3000/4000 Series" and "VFR5000/6000", and table 2 for "VFR2000 Series Non plug-in type" and "VFR3□40, VFR4□40 type of VFR3000/4000 Series".

#### VFR2000 Series

##### Plug-in type (VFR2□00)

Light/Surge voltage suppressor

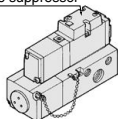

##### Non plug-in type (VFR2□10)

Light/Surge voltage suppressor

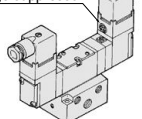

Light/Surge voltage suppressor

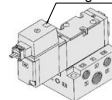

#### VFR3000/4000 Series

##### Plug-in type (VFR3□00/4□00)

Light/Surge voltage suppressor

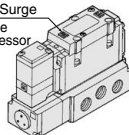

##### Non plug-in type (VFR3□10/4□10)

Light/Surge voltage suppressor

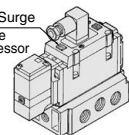

##### Non plug-in type (VFR3□40/4□40)

Light/Surge voltage suppressor

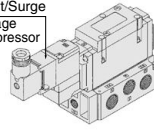

#### VFR5000/6000 Series

##### Plug-in type (VFR5□00/6□00)

Light/Surge voltage suppressor

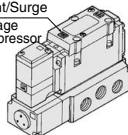

##### Non plug-in type (VFR5□10/6□10)

Light/Surge voltage suppressor

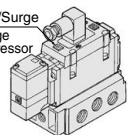

Table (1) VFR2000 Series (VFR2□00)

VFR3000/4000 Series (VFR3□□0, VFR4□□0)  
VFR5000/6000 Series (VFR5□□0, VFR6□□0)

Voltage	Light/Surge voltage suppressor
AC	Single solenoid 
	Double solenoid 
24 VDC or less	Single solenoid 
	Double solenoid 

Table (2) VFR3000/4000 Series (VFR3□10-E, VFR4□10-E)  
VFR5000/6000 Series (VFR5□10-E, VFR6□10-E)

Voltage	Light/Surge voltage suppressor
AC	Single solenoid 
	Double solenoid 
24 VDC or less	Single solenoid 
	Double solenoid 

Table (3) VFR2000 Series (VFR2□10)

VFR3000/4000 Series (VFR3□40, VFR4□40)

Voltage	Light/Surge voltage suppressor
AC	
24 VDC or less	

\* Light/Surge voltage suppressor is not available for grommet type.  
For grommet type with surge voltage suppressor, refer to page 1108.



SV

SYJ

SZ

VF

VP4

VQ

1/2

VQ

4/5

VQC

1/2

VQC

4/5

VQZ

SQ

VFS

VFR

VQ7



# VFR2000/3000/4000/5000/6000 Series Specific Product Precautions 3

Be sure to read this before handling the products. Refer to back page 50 for Safety Instructions and pages 3 to 9 for 3/4/5 Port Solenoid Valve Precautions.

## ⚠ Caution

Plugging one of the cylinder ports (A or B) enables use as a normally closed (N.C.) or normally open (N.O.) 3 port valve. It is convenient when 3 port valve is needed on a manifold, etc., but it can't be used in special applications such as using as a non-leakage valve. Use it with the exhaust port leading open.

Used as a 3 Port Valve		
Plug	B port	A port
Type of actuation	N.C.	N.O.
Number of solenoids	<b>VFR2000/3000/4000</b> 	<b>VFR2000/3000/4000</b> 
	<b>VFR5000/6000</b> 	<b>VFR5000/6000</b> 
Double		

## Change Direction of DIN Connector/Cable Entry

- Unscrew retaining screw, pull off outer cover, rotate connector block through 180°. Replace cover and tighten screw.

## How to Calculate the Flow Rate

For obtaining the flow rate, refer to front matter.

## How to Exchange Solenoid Valves, Pilot Valve Assemblies

### How to exchange solenoid valves

- Loosen set screw and take solenoid valve out vertically, otherwise it may cause damage to the solenoid valve. Never remove valve at an angle.
- When mounting solenoid valve on to the base, plug pin assembly (base-side) into receptacle assembly (body-side) vertically.

### Tightening Torque for Mounting Bolt

Model	Thread	Tightening torque
Pilot valve assembly	M3 (2 pcs.)	0.6 N·m
VFR2000	M3 (3 pcs.)	0.9 N·m
VFR3000	M3 (3 pcs.)	1.1 N·m
VFR4000	M4 (4 pcs.)	1.4 N·m
VFR5000	M5 (4 pcs.)	2.8 N·m
VFR6000	M8 (4 pcs.)	16 N·m

Note) For more information about the procedure, refer to the Operation Manual.

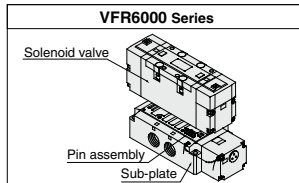
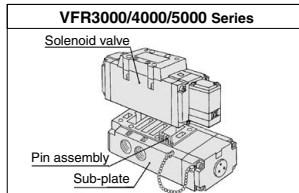
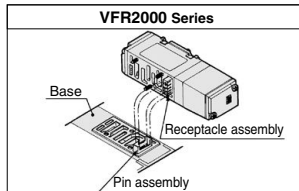

### How to exchange pilot valve assemblies

- Possible to exchange pilot valve assemblies like the following figures.

Note) Do not change the rated voltage.

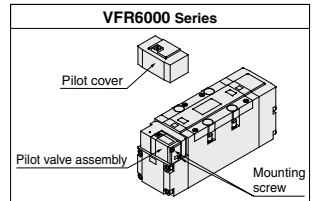
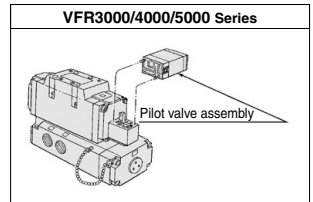
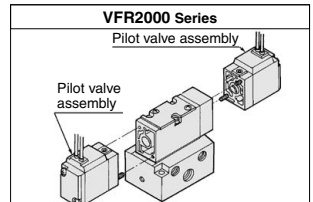





# VFR2000/3000/4000/5000/6000 Series Specific Product Precautions 4

Be sure to read this before handling the products. Refer to back page 50 for Safety Instructions and pages 3 to 9 for 3/4/5 Port Solenoid Valve Precautions.

## Interface Regulator

### ⚠ Caution

### Specifications

Interface regulator	ARB2000	ARB3050	ARB4050	ARB5000	
Applicable solenoid valve series	VFR2000	VFR3000	VFR4000	VFR5000	
Regulating port	P	A B P	A B P	A B P	
Maximum operating pressure	1.0 MPa <sup>(1)</sup>				
Set pressure range	0.05 to 0.83 MPa	0.1 to 0.83 MPa <sup>(2)</sup>			
Ambient and fluid temperature	-5 to 60°C (No freezing) <sup>(3)</sup>				
Port size for connection of pressure gauge	M5 x 0.8	Rc 1/8			
Weight (kg)	0.16	0.46	0.72	0.83	
Effective area at supply side (mm <sup>2</sup> )	P → A	21 18.5 11	35 31 26	44 38 32	
S at P <sub>1</sub> = 0.7 MPa/P <sub>2</sub> = 0.5 MPa	P → B	5.1 18.5 22 12	31 31 24	38 40 31	
Effective area at exhaust side (mm <sup>2</sup> )	A → EA	12	40	55	90
S at P <sub>2</sub> = 0.5 MPa	B → EB	11	36	45	77

Note 1) Maximum operating pressure of solenoid valve is 0.9 MPa.

Note 2) Set the pressure within operating pressure range of solenoid valve.

Note 3) Solenoid valve: Max. 50°C

Note 4) Synthesized effective area with 2 position.

Note 5) • Operate an interface regulator only by applying pressure from the "P" port of the base, except when using it as a reverse pressure valve.

• To combine a pressure center valve and the A and B port pressure reduction interface regulator, use the ARBF3000, ARBF4000, or the ARBF5000 model.

• To combine a reverse pressure valve and an interface regulator, use the ARBF3000, ARBF4000, or the ARBF5000 model. The P port pressure reduction cannot be used.

• When combining a double check valve and an interface regulator, use a manifold or a sub-plate as a basis, and stack them in the following order: the perfect spacer → the interface regulator → the valve.

• When a closed center valve is combined with the interface regulator's A, B port regulation, note that it cannot be used for intermediate stops of a cylinder because there is leakage from relief port on the regulator.

### Flow Rate Characteristics (P → A) (Condition: Inlet pressure 0.7 MPa when 2 position solenoid valve is mounted.)

#### Symbol

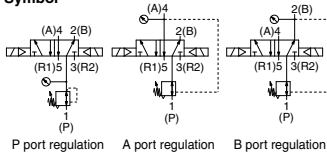

#### ARB2000-00-P

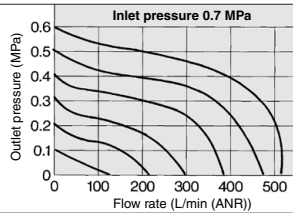

#### ARB3050-00-P

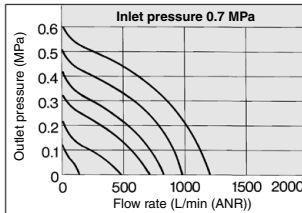

#### ARB4050-00-P

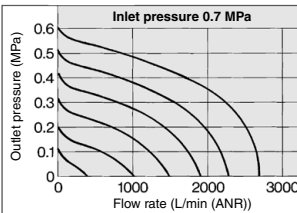

#### ARB5050-00-P

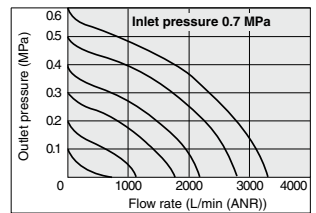

#### ARB3050-00-A

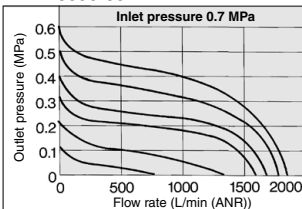

#### ARB4050-00-A

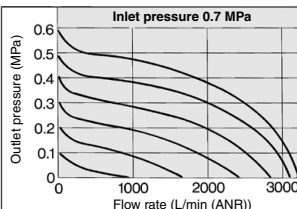

#### ARB5050-00-A

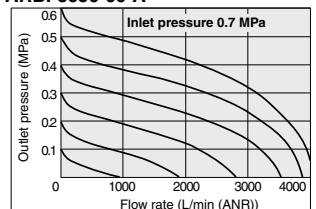

SV  
SYJ  
SZ  
VF  
VP4  
VQ 1/2  
VQ 4/5  
VQC 1/2  
VQC 4/5  
VQZ  
SQ  
VFS  
VFR  
VQ7



# VFR2000/3000/4000/5000/6000 Series Specific Product Precautions 5

Be sure to read this before handling the products. Refer to back page 50 for Safety Instructions and pages 3 to 9 for 3/4/5 Port Solenoid Valve Precautions.

## Lead Wire Connection

### ⚠ Caution

#### Type 01T with Terminal Block

##### VFR2000 Series

- Remove junction cover of manifold, exposing terminal block attached to the manifold block. Lead wires from solenoid valve are connected with the terminals on upper side of terminal block. (On the terminal block, lead wire is connected with both A and B sides of solenoid valve in accordance with the corresponding markings A and B on the block.)

Connect each lead wire of power side corresponding to respective solenoid valve on the lower terminal block.

Terminal block wiring specifications is in accordance with COM.

Model	A -	B +	B -
VFR2100	A side	COM	
VFR2200	A side	COM	B side
VFR2 <sup>3</sup> / <sub>5</sub> 00	A side	COM	B side

- Applicable terminal: 1.25-3, 1.25-3S, 1.25Y-3N, 1.25Y-3S
- Although "A-", "B+" and "B-" marks are indicated on the terminal block, VFR2000 can be used as either "+COM" or "-COM".

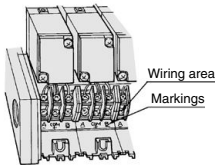

##### VFR4000 Series

Model	A -	B +	B -
VFR4100	A side	COM	
VFR4200	A side	COM	B side
VFR4 <sup>3</sup> / <sub>5</sub> 00	A side	COM	B side

- Applicable terminal: 1.25-3.5M, 1.25Y-3L, 1.25-3M
- Although "A-", "B+" and "B-" marks are indicated on the terminal block, VFR4000 can be used as either "+COM" or "-COM".

##### VFR5000 Series

Model	A -	B +	B -
VFR5100	A side	COM	
VFR5200	A side	COM	B side
VFR5 <sup>3</sup> / <sub>5</sub> 00	A side	COM	B side

- Applicable terminal: 1.25-3.5M, 1.25Y-3L, 1.25-3M
- Although "A-", "B+" and "B-" marks are indicated on the terminal block, VFR5000 can be used as either "+COM" or "-COM".

##### VFR3000 Series

Model	A -	COM +	B -
VFR3100	A side	COM	
VFR3200	A side	COM	B side
VFR3 <sup>3</sup> / <sub>5</sub> 00	A side	COM	B side

- Applicable terminal: 1.25-3.5M, 1.25Y-3L, 1.25-3M
- Although "A-", "COM+" and "B-" marks are indicated on the terminal block, VFR3000 can be used as either "+COM" or "-COM".



# VFR2000/3000/4000/5000/6000 Series Specific Product Precautions 6

Be sure to read this before handling the products. Refer to back page 50 for Safety Instructions and pages 3 to 9 for 3/4/5 Port Solenoid Valve Precautions.

## ⚠ Caution

### Lead Wire Connection

### Manifold/Plug-in Type

#### Type 01C Circular Connector

##### VFR2000/3000/4000/5000 Series

- When multi-connector is used, mass-termination between power supply side and solenoid valve can be done. This saves the wiring connection labor.
- Wire connection specifications  
Lead wire for both solenoid A and B sides in manifold are connected to connector terminal as COM specifications.

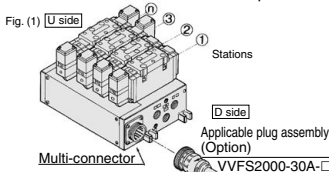

#### Type 01F D-sub Connector

##### VFR2000/3000/4000/5000 Series

- MIL standard type D connector (Terminal: 25 pins) has wide exchangeability and saves wiring labor.
- Wire connection specifications  
Lead wire for both solenoid A and B sides in manifold are connected to connector terminal as COM specifications.

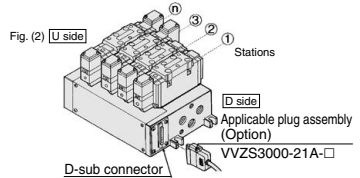

### Manifold internal wiring

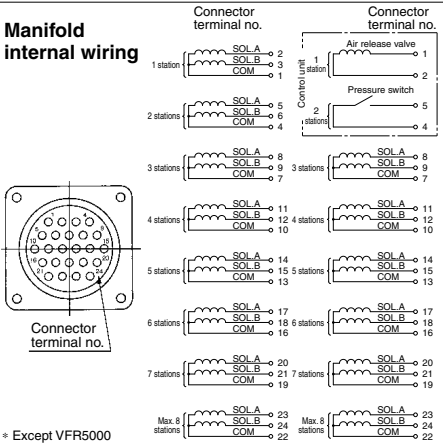

Note 1) Maximum number is 8 stations. Note 2) It is used as +COM and -COM.  
Note 3) Station numbers are started from D side although connector is mounted on D or U Side.

### Applicable Plug Assembly (Option)

Assembly part no.	Cable length	Component parts
VVFS2000-30A-1	1.5 m	Plug 206837-1 1 pc. Cable clamp 206138-1 1 pc. Socket 66101-2 24 pcs. Cable VCTF 24 cores x 0.75 mm <sup>2</sup> made by Tyco Electronics AMP K.K.
VVFS2000-30A-2	3 m	
VVFS2000-30A-3	5 m	
VVFS2000-30A-4 *	7 m	
VVFS2000-30A-5 *	10 m	
VVFS2000-30A-6 *	15 m	
VVFS2000-30A-7 *	20 m	

\* Option

### Cable Color List of Each Terminal No.

Terminal no.	1	2	3	4	5	6	7	8	9	10	11	12	13
Lead wire color	Orange	Orange	Black	Black	Green	Green	Red	Red	Blue	Blue	Yellow	Yellow	Black
Dot marking	—	Yes	—	Yes	—	Yes	—	Yes	—	Yes	—	Yes	—

Terminal no.	14	15	16	17	18	19	20	21	22	23	24
Lead wire color	Brown	White	White	Pink	Pink	Gray	Gray	Sky blue	Sky blue	Light green	Light green
Dot marking	Yes	—	Yes	—	Yes	—	Yes	—	Yes	—	Yes

### Manifold internal wiring

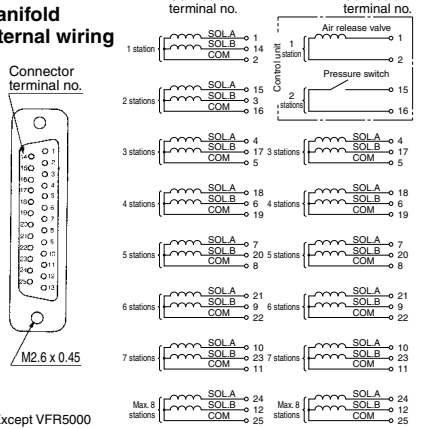

Note 1) Maximum number is 8 stations. Note 2) It is used as +COM and -COM.  
Note 3) Station numbers are started from D side although connector is mounted on D or U Side.

### Applicable Plug Assembly (Option)

Assembly part no.	Cable length	Component parts
VVZS3000-21A-1	1.5 m	Plug MIL standard type D connector Number of terminals: 25 pins Cable: 25 cores x 0.3 mm <sup>2</sup>
VVZS3000-21A-2	3 m	
VVZS3000-21A-3	5 m	
VVZS3000-21A-4 *	8 m	
VVZS3000-21A-5 *	10 m	
VVZS3000-21A-6 *	15 m	
VVZS3000-21A-7 *	30 m	
VVZS3000-21A-8 *	20 m	

\* Option

### Cable Color List of Each Terminal No.

Terminal no.	1	2	3	4	5	6	7	8	9	10	11	12
Lead wire color	Black	Brown	Red	Orange	Yellow	Pink	Blue	Purple	Blue	Gray	White	White
Dot marking	—	—	—	—	—	—	—	—	—	White	Black	Black

Terminal no.	13	14	15	16	17	18	19	20	21	22	23	24	25
Lead wire color	Orange	Yellow	Pink	Blue	Purple	Gray	Orange	Red	Brown	Pink	Gray	Black	White
Dot marking	Red	Black	Black	White	—	—	Black	White	White	Red	Red	White	—

SV  
SYJ  
SZ  
VF  
VP4  
VQ 1/2  
VQ 4/5  
VQC 1/2  
VQC 4/5  
VQZ  
SQ  
VFS  
VFR  
VQ7

