



MICRO SWITCH™
Door Switches
AC Series



Datasheet

MICRO SWITCH™ AC Series Door Switches

When the application is more complex than a “stand alone” switch can provide, consider the MICRO SWITCH™ AC Series Door Switch. The AC Series switch assembly monitors the position of a service door or panel whether “closed” or “open”. The AC Series switches are a compact switch assembly designed for equipment applications ranging from vending machine service doors or panels, monitoring doors for truck trailers, and military-related doors and/or panels. When the equipment (door or panel, etc.) which is electrically interlocked through the AC Series switch is opened, the action of the AC Series switch disconnects the electrical power. The AC Series switch can provide an electrical signal to an annunciator circuit such as a light or horn indicating the door or panel is open. Another feature that is common to most AC Series switch assemblies is a “pull-to-override” position which allows the service door to be open and yet apply electrical power through the switch assembly. The “pull-to-override” switch position could be useful for trouble shooting equipment as required.

AC Series switch assemblies are available with up to four switch elements which can provide discrete outputs as required for control and/or indicator circuits. Select catalog listings are available with UL and CSA agency certification. Where the application is military related, catalog listings are available with a military specification part number.

What makes our switches better?

- Available with Honeywell MICRO SWITCH™ V3, V7, SM, SE, or BZ Series switches; there are no exposed contacts
- Temperature ranges (-40 °C to 85 °C [-40 °F to 185 °F]) allow for reliable performance usage in harsh conditions
- Many catalog listings have internal threaded actuators that allow customers to attach auxiliary plungers
- Choice of switch actuation: two position momentary, two position momentary with a twist-latch feature, or a three position with push momentary and pull maintained action



Right form factor combined with the right operating characteristics make a precise combination for door switch applications.

RIGHT SWITCH FOR THE RIGHT APPLICATION
PERFORMANCE • RELIABILITY

Features and Benefits

RELIABLE PERFORMANCE

The switch automatically disconnects electrical power to equipment when service door, panel, or drawer is opened.

CHOICE OF SWITCH ACTUATION

Choose the standard switch assembly with one of three mechanical positions: push-momentary with a pull-to-override maintained position, the two position momentary switch assembly, or the two position switch assembly with a push-momentary and a push-and-turn-to-latch maintained position.

Enhanced switch offerings

MOUNTING EASE

The switch assembly is designed to be installed as a side mount or end mount for versatility.

WIDE ELECTRICAL RANGE

Wide range of current from less than 1 A to 21 A to interface with control and signal circuits.

Tough answer for tough door interlock needs

AGENCY CERTIFICATIONS

Select switch assemblies are certified to CSA and UL component recognition where agency certification is desired or required. When the application involves military requirements, several different styles of AC Series door switches are offered with military specifications.

CIRCUIT FLEXIBILITY

Switch assemblies are available with single throw or double throw action with up to four poles to provide control circuits and optional signal circuits as required.

TERMINATION OPTIONS

Two different types of switch termination (screw or quick connect blades) are available to meet machine design requirements.

Potential Applications



VENDING MACHINES

Indicates front panel of vending machine is closed

HVAC EQUIPMENT

Serves as interlock for one or more service panels

APPLIANCES

Equipped as interlock for service panels or access panels



COMMUNICATION EQUIPMENT

Provides interlocking capability for service or access panels

BUSINESS EQUIPMENT

Provides interlocking capability for service or access panels

TRUCK TRAILER OR SEMI-TRUCK TRAILER DOORS

Indicates the door is closed and/or latched



COMMERCIAL DOORS AND GATES

Monitors the door or gate is open or closed

MILITARY EQUIPMENT

Serves as a cabinet and service panel interlock for land-based electrical/electronic equipment

MICRO SWITCH™ Door Switches

F.P. • Free Position
O.P. • Operating Position
D.P. • Depressed Position

Table 1. Specifications • Metal Plunger







| | Catalog Listing | Figure No. | Description | Switch Type | Elec. Rating | Plunger Action | F.P. max. mm [in.] | O.P. min. mm [in.] | D.P. max. mm [in.] |
|---|-------------------|------------|---|-------------|--------------|---|--------------------|--------------------|--------------------|
|  | 1AC2 | 1 | SPDT (1), screw terminals, threaded plunger | BZ | A | 3 position, push-momentary, pull-maintained | 11,1 [0.438] | 6,35 [0.25] | 3,17 [0.125] |
|  | 2AC59 (MS16106-1) | 3 | SPDT (1), screw terminals, threaded plunger | V3 | E | 3 position, push-momentary, pull-maintained | 9,53 [0.375] | 5,16 [0.203] | 3,17 [0.125] |
|  | 2AC6 | 2 | SPDT (1), screw terminals, threaded plunger | V3 | C | 3 position, push-momentary, pull-maintained | 9,53 [0.375] | 5,16 [0.203] | 3,17 [0.125] |
|  | 8AC1 | 6 | SPDT (4), solder terminals | SM | B | 3 position, push-momentary, pull-maintained | 9,53 [0.375] | 5,16 [0.203] | 3,17 [0.125] |
|  | 13AC1 | 8 | SPDT (1), screw terminals, threaded plunger | V3 | C | 2 position (special), push-momentary, push & twist maintained | 15,9 [0.625] | 12,3 [0.485] | 6,68 [0.263] |
|  | 17AC1-T | 9 | SPDT (1), solder terminals | SM | B | 3 position, push-momentary, pull-maintained | 9,53 [0.375] | 5,59 [0.22] | 4,45 [0.175] |

Table 2. Electrical Ratings (in amperes)

| Rating Code | Electrical Rating |
|-------------|---|
| A | 15 A, 125, 250, or 480 Vac; 1/2 A, 125 Vdc; 1/4 A, 250 Vdc |
| B | 5 A, 125 or 250 Vac 30 Vdc ind.: 3 A (sea level) and 2.5 A (50,000 ft) 30 Vdc res: 5 A (sea level and 50,000 ft); max. in-rush 24 A |
| C | 15 A, 125 or 250 Vac; 5 A, 125 Vac "L"; 1/2 A, 125 Vdc; 1/4 A, 250 Vdc; 1/2 hp, 125 or 250 Vac |
| D | 21 A, 1 hp 125, 250, 277 Vac; 2 hp 250, 277 Vac |
| E | 10 A res. and ind. (sea level), 28 Vdc and 125 Vac 10 A res. (50,000 ft), 28 Vdc and 125 Vac 10 A ind. (50,000 ft), 125 Vac 6 A ind. (50,000 ft), 28 Vdc |
| F | 5 A, 125, 250, 277 Vac 1/10 hp, 250 Vac |

AC Series

F.P. • Free Position
 O.P. • Operating Position
 D.P. • Depressed Position

Table 3. Specifications • Plastic Plunger

| | Catalog Listing | Figure No. | Description | Switch Type | Elec. Rating | Plunger Action | F.P. max. mm [in.] | O.P. min. mm [in.] | D.P. max. mm [in.] |
|---|-------------------|------------|---|-------------|--------------|---|--------------------|--------------------|--------------------|
|  | 8AC9 (MS16106-3) | 7 | SPDT (4), solder terminals, threaded plunger | SM | B | 3 position, push-momentary, pull-maintained | 9,52 [0.375] | 5,15 [0.203] | 3,17 [0.125] |
|  | 22AC1 | 10 | SPDT (1), screw terminals | V3 | C | 3 position, push-momentary, pull-maintained | 9,52 [0.375] | 5,15 [0.203] | 3,17 [0.125] |
|  | 22AC2 | 11 | SPDT (1), screw terminals, threaded plunger | V3 | C | 3 position, push-momentary, pull-maintained | 9,52 [0.375] | 5,15 [0.203] | 3,17 [0.125] |
|  | 22AC2-UL | 12 | SPDT (1), screw terminals, threaded plunger | V3 | C | 3 position, push-momentary, pull-maintained | 9,52 [0.375] | 5,15 [0.203] | 3,17 [0.125] |
|  | 23AC2 | 13 | SPDT (1), screw terminals, threaded plunger | V3 | C | 3 position, push-momentary, pull-maintained | 9,52 [0.375] | 5,15 [0.203] | 3,17 [0.125] |
|  | 23AC81 | 14 | SPDT (1), quick connect terminals, threaded plunger | V7 | F | 2 position, push-momentary | 9,52 [0.375] | 5,15 [0.203] | 3,17 [0.125] |
|  | 24AC1 | 15 | SPDT (2), screw terminals | V3 | C | 3 position, push-momentary, pull-maintained | 9,52 [0.375] | 4,75 [0.187] | 3,17 [0.125] |
|  | 4AC54 (MS16106-2) | 4 | SPDT (2), screw terminals, threaded plunger | V3 | E | 3 position, push-momentary (1 sw.), pull-maintained (both switches) | 9,52 [0.375] | 4,75 [0.187] | 3,17 [0.125] |
|  | 4AC55 (MS16106-5) | 5 | SPDT (2), screw terminals, threaded plunger | V3 | E | 3 position, push-momentary, pull-maintained | 9,52 [0.375] | 4,75 [0.187] | 3,17 [0.125] |
|  | 423AC2-E9 | 16 | SPDT (1), quick-connect terminals, threaded plunger | V7 | D | 3 position, push-momentary, pull-maintained | 9,52 [0.375] | 5,15 [0.203] | 3,17 [0.125] |

MICRO SWITCH™ Door Switches

GENERAL DIMENSIONS

Figure 1. MICRO SWITCH™ 1AC2

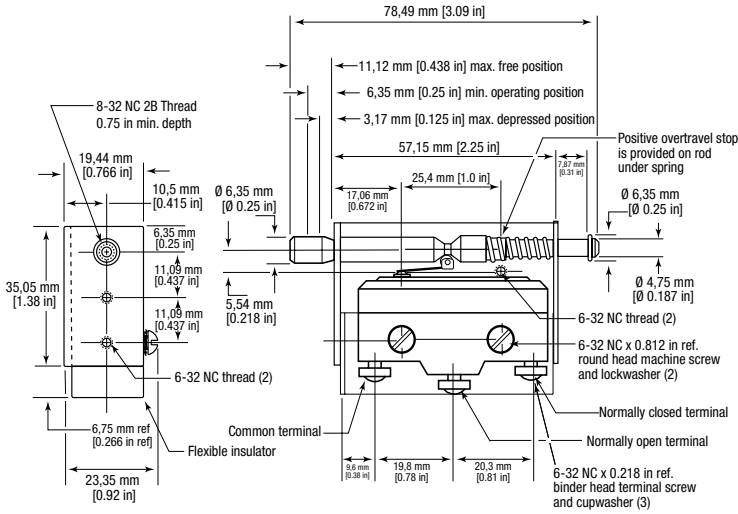

Figure 2. MICRO SWITCH™ 2AC6

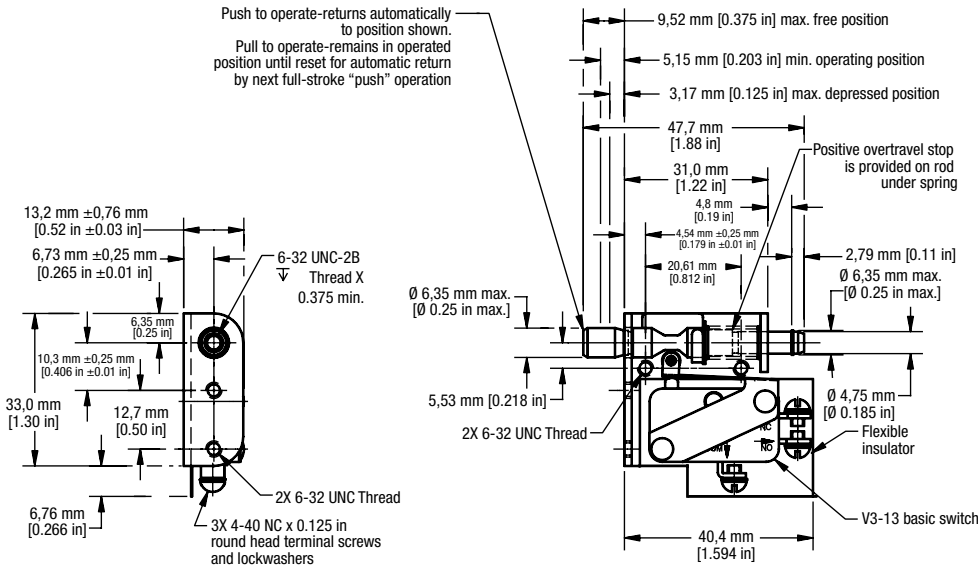
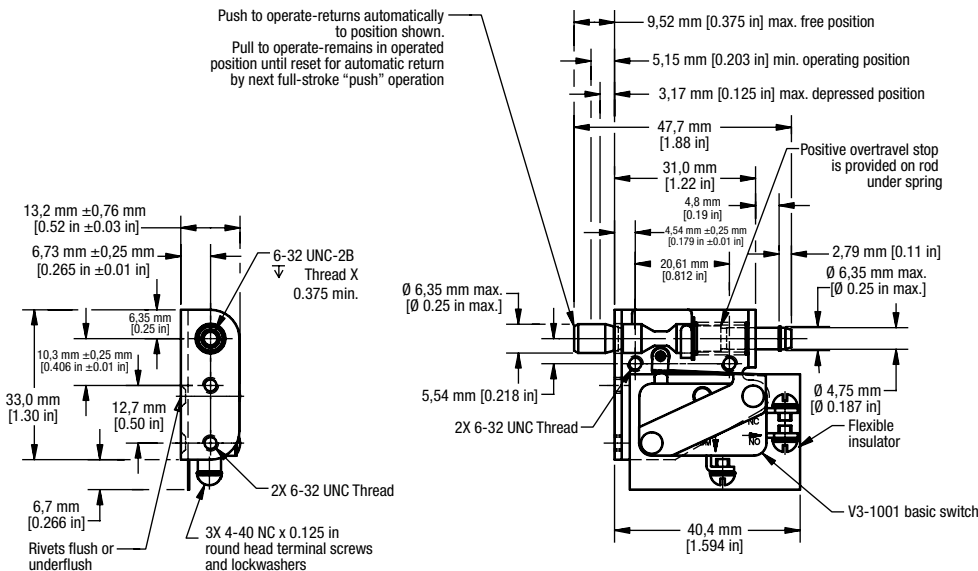

Figure 3. MICRO SWITCH™ 2AC59



AC Series

Figure 4. MICRO SWITCH™ 4AC54

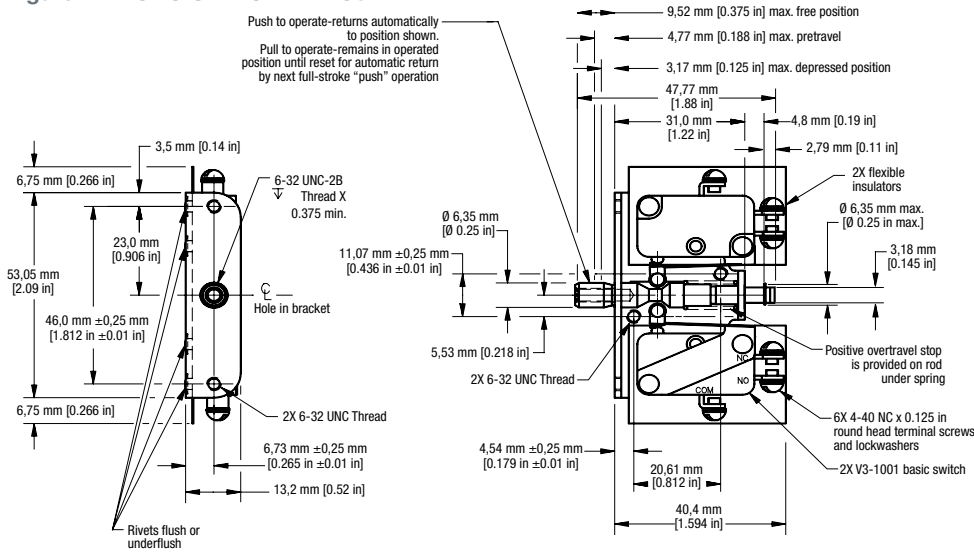

Figure 5. MICRO SWITCH™ 4AC55

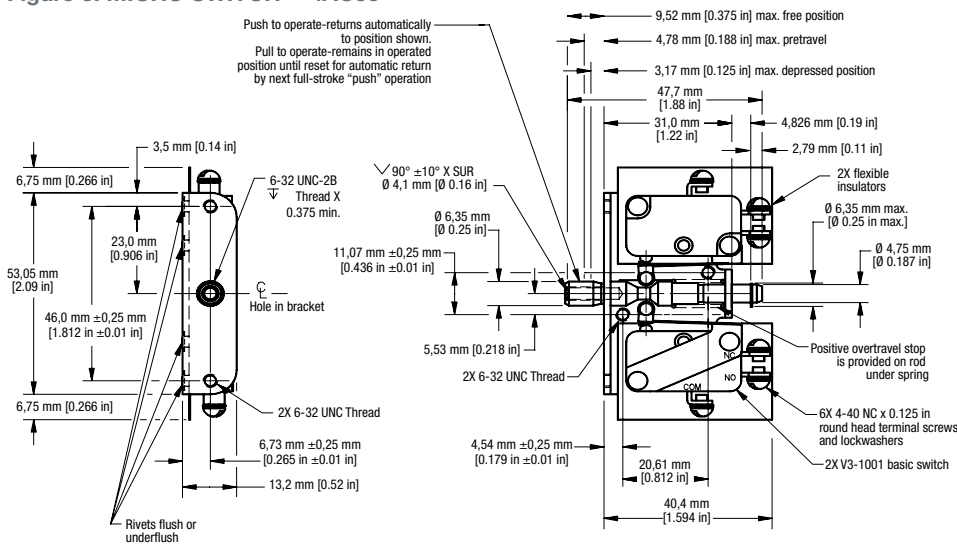
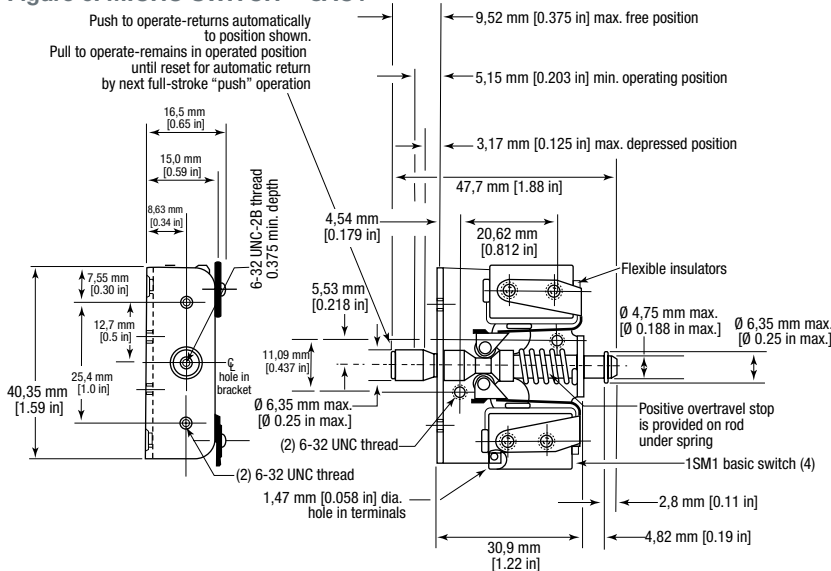

Figure 6. MICRO SWITCH™ 8AC1



MICRO SWITCH™ Door Switches

Figure 7. MICRO SWITCH™ 8AC9

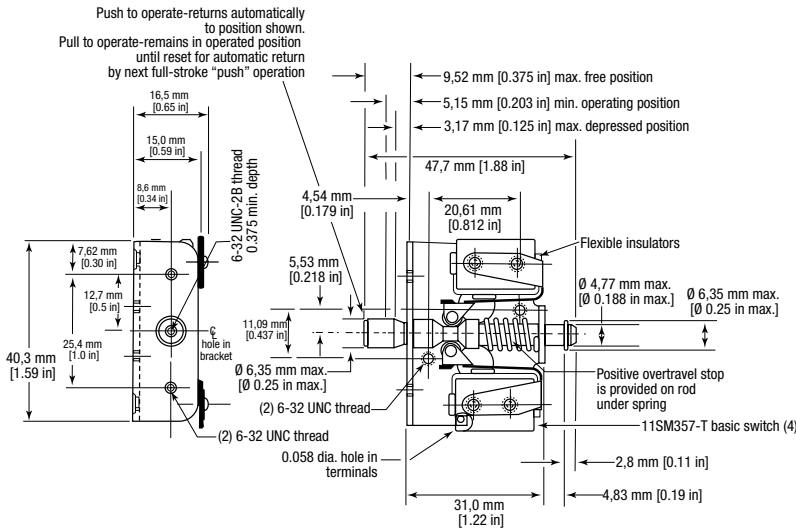

Figure 8. MICRO SWITCH™ 13AC1

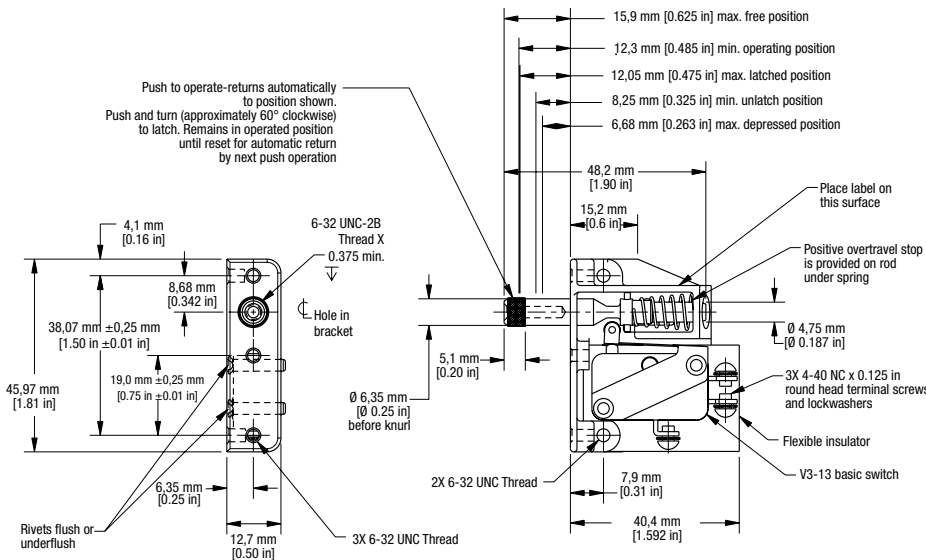
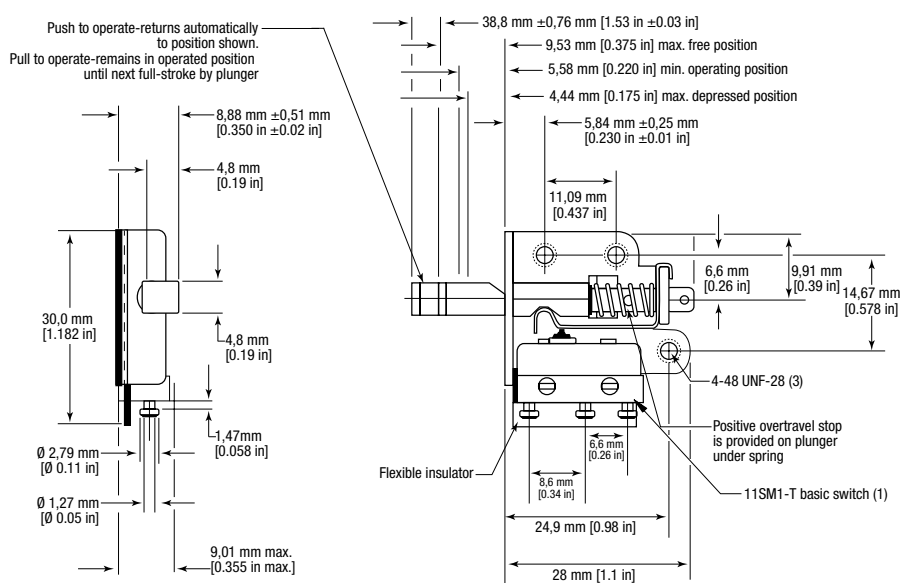

Figure 9. MICRO SWITCH™ 17AC1-T



AC Series

Figure 10. MICRO SWITCH™ 22AC1



Figure 11. MICRO SWITCH™ 22AC2

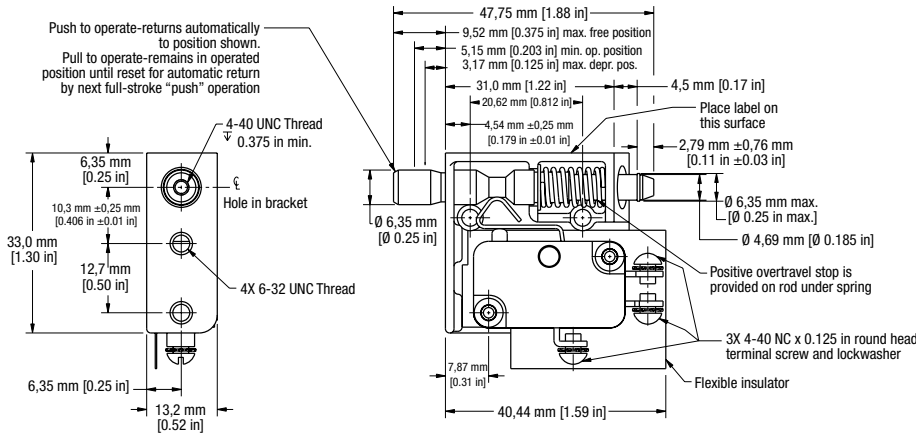
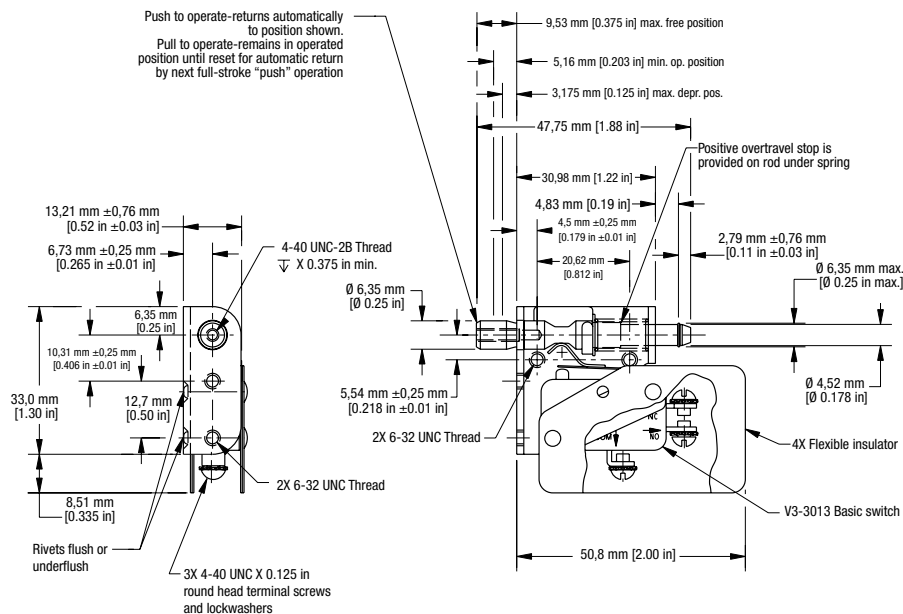

Figure 12. MICRO SWITCH™ 22AC2-UL



MICRO SWITCH™ Door Switches

Figure 13. MICRO SWITCH™ 23AC2



Figure 14. MICRO SWITCH™ 23AC81

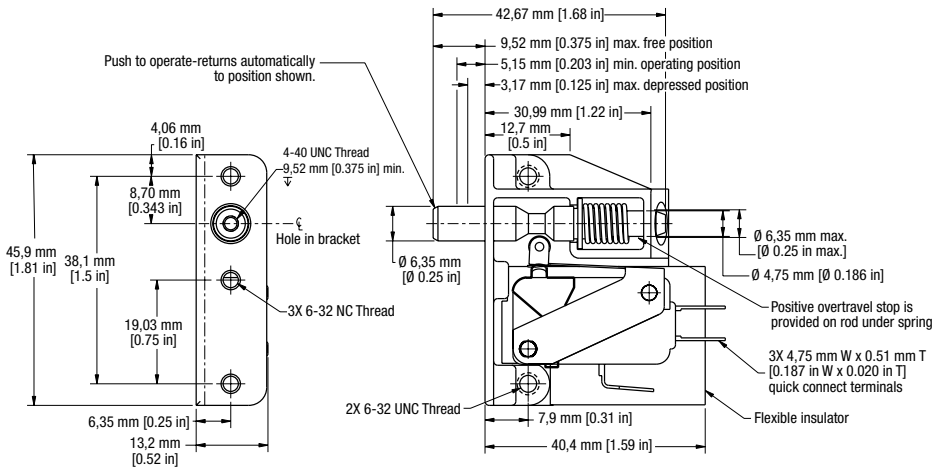
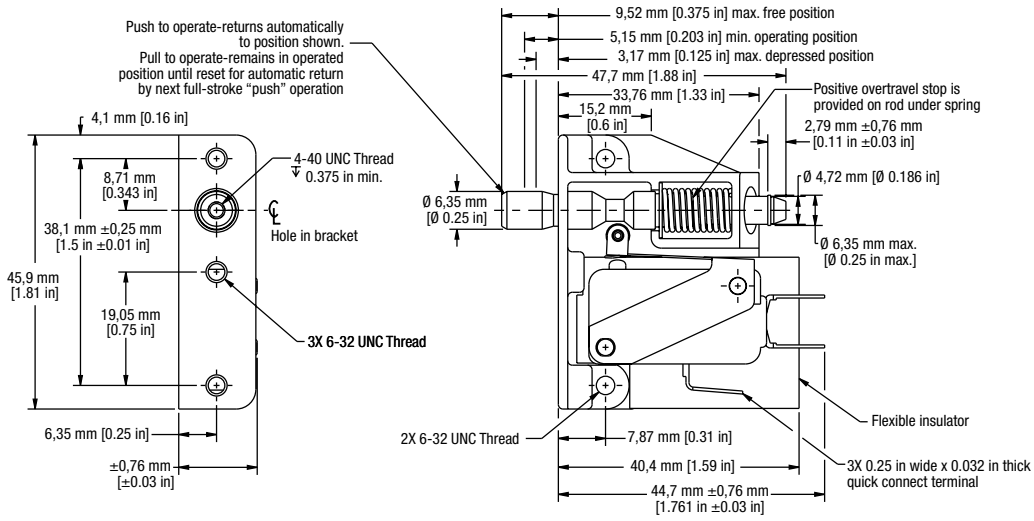

Figure 15. MICRO SWITCH™ 24AC1



AC Series

Figure 16. MICRO SWITCH™ 423AC2-E9



MICRO SWITCH™ Door Switches

ADDITIONAL INFORMATION

The following associated literature is available on the Honeywell web site at sensing.honeywell.com:

- Product installation instructions
- Product range guide
- Product application-specific information
 - Technical note: Applying precision switches

This datasheet supports the following MICRO SWITCH™

AC Series Door Switches

| | |
|------------|-----------|
| 13AC1 | 2AC19 |
| 17AC18-T | 2AC59 |
| 17AC1-T | 2AC6 |
| 17AC28-H58 | 2AC97-D8 |
| 17AC34-T | 3AC120 |
| 1AC1 | 3AC49 |
| 1AC2 | 3AC5 |
| 1AC24 | 3AC6 |
| 22AC1 | 3AC68 |
| 22AC1-D8 | 3AC6-D8 |
| 22AC2 | 423AC2-E9 |
| 22AC2-D8 | 4AC54 |
| 22AC2-UL | 4AC55 |
| 23AC2 | 4AC60 |
| 23AC80 | 4AC79 |
| 23AC80-UL | 4AC8 |
| 23AC81 | 7AC12 |
| 23AC82 | 7AC7 |
| 24AC1 | 8AC1 |
| 24AC22 | 8AC27 |
| 24AC27-D9 | 8AC29-UL |
| 2AC109 | 8AC9 |
| 2AC110 | |

WARNING

PERSONAL INJURY

DO NOT USE these products as safety or emergency stop devices or in any other application where failure of the product could result in personal injury.

Failure to comply with these instructions could result in death or serious injury.

WARNING

MISUSE OF DOCUMENTATION

- The information presented in this product sheet is for reference only. Do not use this document as a product installation guide.
- Complete installation, operation, and maintenance information is provided in the instructions supplied with each product.

Failure to comply with these instructions could result in death or serious injury.

WARRANTY/REMEDY

Honeywell warrants goods of its manufacture as being free of defective materials and faulty workmanship. Honeywell's standard product warranty applies unless agreed to otherwise by Honeywell in writing; please refer to your order acknowledgement or consult your local sales office for specific warranty details. If warranted goods are returned to Honeywell during the period of coverage, Honeywell will repair or replace, at its option, without charge those items it finds defective. **The foregoing is buyer's sole remedy and is in lieu of all other warranties, expressed or implied, including those of merchantability and fitness for a particular purpose. In no event shall Honeywell be liable for consequential, special, or indirect damages.**

While we provide application assistance personally, through our literature and the Honeywell website, it is up to the customer to determine the suitability of the product in the application.

Specifications may change without notice. The information we supply is believed to be accurate and reliable as of this printing. However, we assume no responsibility for its use.

Find out more

Honeywell serves its customers through a worldwide network of sales offices, representatives and distributors. For application assistance, current specifications, pricing or name of the nearest Authorized Distributor, contact your local sales office.

To learn more about Honeywell's sensing and control products, call **+1-815-235-6847** or **1-800-537-6945**, visit **sensing.honeywell.com**, or e-mail inquiries to **info.sc@honeywell.com**

Sensing and Control
Honeywell
1985 Douglas Drive North
Golden Valley, MN 55422
honeywell.com

The Honeywell logo is displayed in a bold, red, sans-serif font.

004981-1-EN IL50 GLO
May 2014
Copyright © 2014 Honeywell International Inc. All rights reserved.