

Hexagon Wrench Adjustable Metal Speed Controller with Indicator

New

RoHS

Improved environmental resistance with the all metal exterior With indicator

For use in environment with Welding spatter (Option BH type)

Contributes to reducing setting time and errors by allowing the user to adjust flow rate before mounting and operating the cylinder

Possible to manage the flow rate values using an indicator!



0	Fully closed state
5	Five turns of the needle
Horizontal line	Printed per one turn of the needle

[Indicator visibility]
1/8 to 1/2 sizes: 4 directions
M5 size: 2 directions



Flow adjustable with a hexagon wrench tool
Prevents accidental manual operation

Adjustment needle lock nut feature as standard With indicator

Prevents unauthorized adjustment and unwanted operation of the needle from the set position due to vibrations or impacts. Helps improve safety in your machinery.



2 types are available for different applications.

For welding environments

For general environments

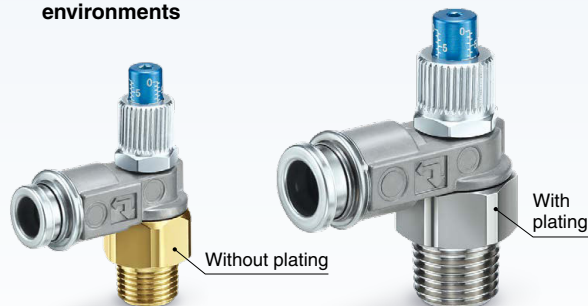

Variations

One-touch fitting type	Port size	Applicable tubing O.D.		
		Metric size	Inch size	
	M5 x 0.8	4, 6	—	
	10-32UNF	—	5/32", 1/4"	
	R G NPT	1/8	6, 8	1/4", 5/16"
		1/4	6, 8, 10	1/4", 5/16", 3/8"
		3/8	8, 10	5/16", 3/8"
1/2		10, 12	3/8", 1/2"	

* Metric size: R, G only, Inch size: NPT only

Related equipment Spatter cover p. 6

Prevents adhesion and entry of welding spatters

Made of flexible silicone rubber which conforms to the tube

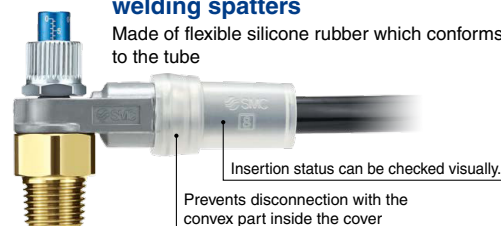

* Option BH (body without electroless nickel plating) is recommended for use in welding environments.

ASB-□H Series



CAT.ES20-289A

Hexagon Wrench Adjustable Metal Speed Controller with Indicator

ASB-□H Series

RoHS

Model

One-touch fitting type

Model*2	Port size	Seal method	Applicable tubing O.D.													
			Metric size (Applicable thread: R, G)					Inch size (Applicable thread: NPT)								
			4	6	8	10	12	5/32"	1/4"	5/16"	3/8"	1/2"				
ASB12□1-M5-□	M5 x 0.8	Gasket seal	●	●												
ASB12□1-U10/32-□	10-32UNF							●	●							
ASB22□1-□01-□	R G NPT	Sealant (R/NPT)*1 Face seal (G)		●	●					●	●					
ASB22□1-□02-□			1/8		●	●				●	●	●				
ASB32□1-□03-□			1/4		●	●	●				●	●	●			
ASB42□1-□04-□			3/8			●	●					●	●	●		
	1/2				●	●						●	●			

*1 "Without sealant" type can be selected as a standard option.

*2 Meter-out and meter-in types can be visually differentiated by the flow direction symbol on the body.

Flow Direction Symbols on Body

	Meter-out	Meter-in
Indication symbol		
Symbol		

Specifications

Fluid	Air
Proof pressure	1.5 MPa
Max. operating pressure	1 MPa
Min. operating pressure	0.1 MPa
Ambient and fluid temperatures	-5 to 60°C (No freezing)
Applicable tubing material*1, *2	FEP, PFA, Nylon, Soft nylon, Polyurethane, Polyolefin

*1 Check the max. operating pressure of the tubing. (Please refer to the **Web Catalog** for details.)

*2 Tubing with inner layer of these materials is applicable.

SMC tubing: TRBU (FR double layer), TRTU (FR three-layer), TRS (FR soft nylon), etc.

Flow Rate and Sonic Conductance

Model		ASB12□1-M5-□	ASB12□1-U10/32-□	ASB22□1-□01-□	ASB22□1-□02-□	ASB32□1-□03-□	ASB42□1-□04-□	
		ø4, ø6	ø5/32", ø1/4"	ø6, ø1/4", ø8, ø5/16"	ø6, ø1/4", ø8, ø5/16", ø10, ø3/8"	ø8, ø5/16"	ø10, ø3/8"	ø10, ø3/8", ø12, ø1/2"
C values: Sonic conductance dm ³ /(s·bar)	Free flow	0.3	0.3	0.7	1.4	2.7	2.9	4.8
	Controlled flow	0.3	0.3	0.7	1.8	2.8	3.0	4.9
b values: Critical pressure ratio	Free flow	0.2	0.2	0.25	0.3	0.25	0.25	0.25
	Controlled flow	0.4	0.4	0.2	0.3	0.2	0.2	0.3

* C and b values are for controlled flow with the needle fully open and free flow with the needle fully closed.

Hexagon Wrench Adjustable Metal Speed Controller with Indicator **ASB-□H Series**

How to Order

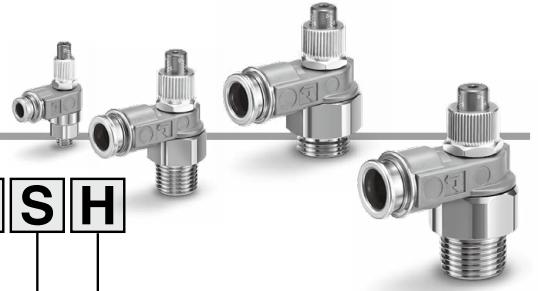

ASB 2 2 0 1 - □ 01 - 06 S H

Body size

1	M5 x 0.8 10-32UNF
2	1/8, 1/4
3	3/8
4	1/2

Elbow

Control type

0	Meter-out
1	Meter-in

Thread type

Nil	R
N	NPT
G	G

Port size

M5	M5 x 0.8
U10/32	10-32UNF
01	1/8
02	1/4
03	3/8
04	1/2

Adjustment option

H	For general environments	Brass parts (external): Ni plating
BH	For welding environments	Brass parts (external): No plating

Seal method

Nil	Without sealant
S	With sealant

Applicable tubing O.D.

Metric size		Inch size	
04	ø4	03	ø5/32"
06	ø6	07	ø1/4"
08	ø8	09	ø5/16"
10	ø10	11	ø3/8"
12	ø12	13	ø1/2"

Needle Valve: Flow Rate Characteristics

ASB12□1-M5-□

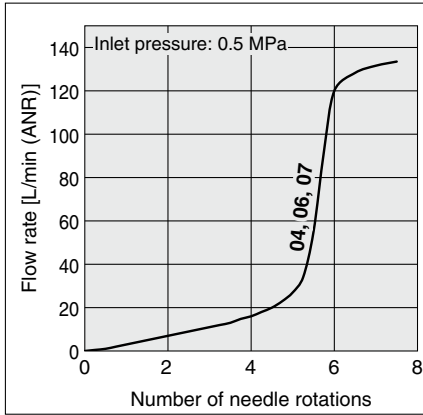

ASB22□1-01-□

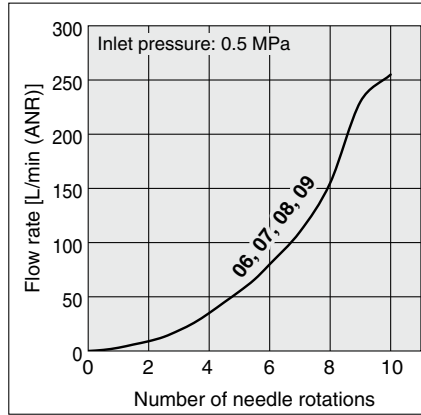

ASB22□1-02-□

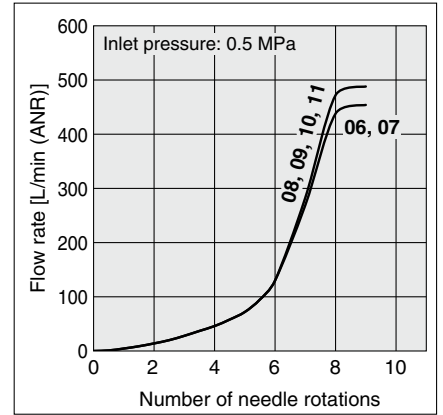

ASB32□1-03-□

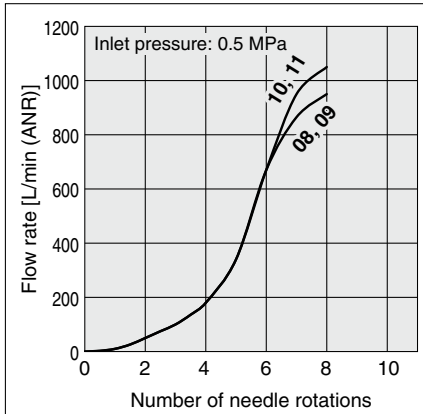

ASB42□1-04-□

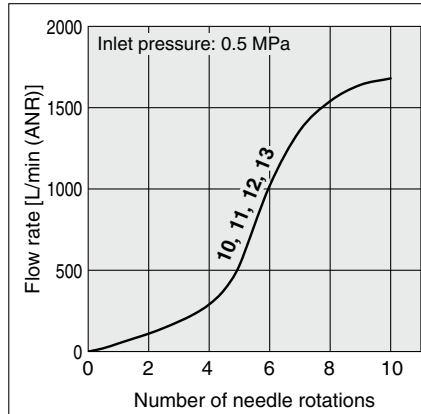

* The flow rate characteristics are representative values.

* The numbers above the flow rate characteristic curves in the charts show the applicable tubing outside diameter as defined by the product number.

Construction

Seal method: Gasket seal
For M5, 10-32UNF

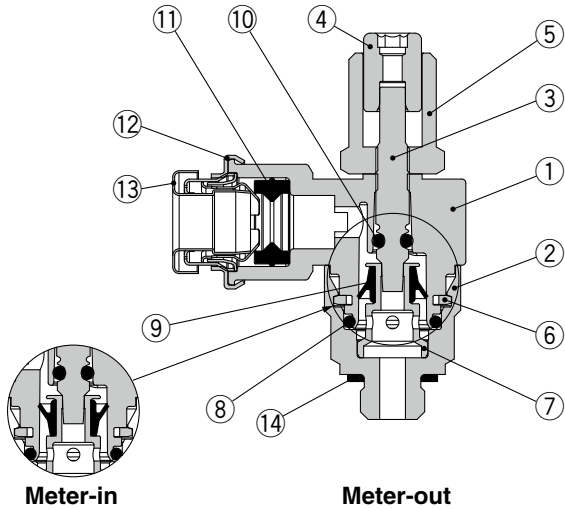

Seal method: Sealant
For R, NPT thread

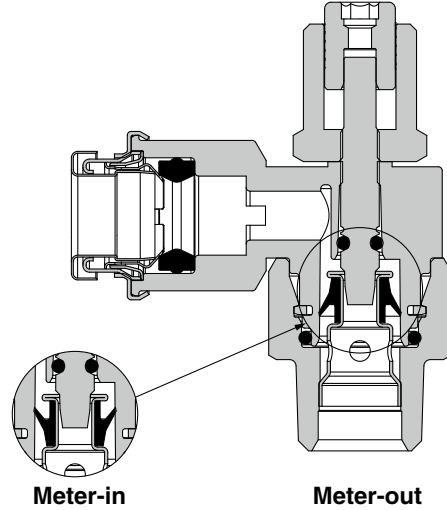

Seal method: Face seal
For G thread

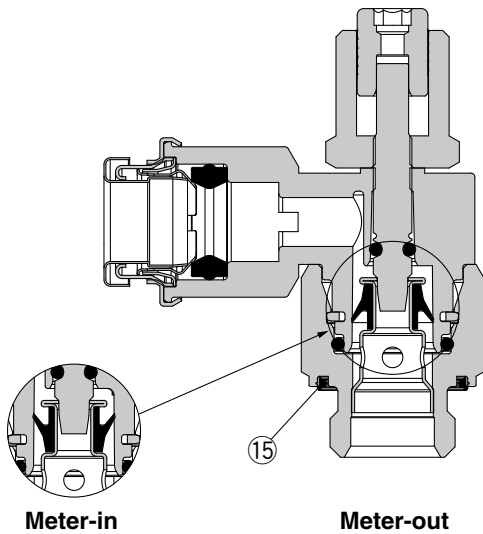

Component Parts

No.	Description	Material	Note
1	Body A	Zinc alloy	
2	Body B	Brass	Electroless nickel plating*1
3	Needle	Brass	Electroless nickel plating*1
4	Cap	Aluminum alloy	
5	Lock nut	Aluminum alloy	
6	C-ring	Stainless steel	
7	Seat ring	Brass	Electroless nickel plating*1
8	O-ring	NBR	
9	U-seal	HNBR	
10	O-ring	NBR	
11	Seal	FKM	
12	Cover	Stainless steel	
13	Cassette	Stainless steel	
14	Gasket	Stainless steel/NBR	M5, U10-32 type
15	Seal	NBR	G thread type

*1 Adjustment option BH specifies the body without electroless nickel plating.

ASB-□H Series

For M5, R, NPT Thread

Dimensions

One-touch fitting type
Seal method: Gasket seal
For M5

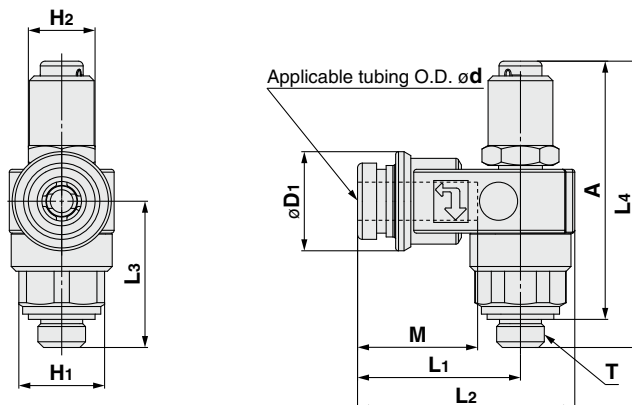

Metric Size

Model	d	T	H1	H2	D1	A	L1	L2	L3	L4	M	Weight [g]
						Max.				Max.		
ASB12□1-M5-04H	4	M5 x 0.8	9	7	10.4	30.1	17.1	22.8	15.4	33.1	12.6	12
ASB12□1-M5-06H	6				13.1							

Inch Size

Model	d	T	H1	H2	D1	A	L1	L2	L3	L4	M	Weight [g]
						Max.				Max.		
ASB12□1-U10/32-03H	5/32	10/32 UNF	9	7	10.4	30.1	17.1	22.8	15.4	33.1	12.6	12
ASB12□1-U10/32-07H	1/4				13.1							

One-touch fitting type
Seal method: Sealant
For R, NPT thread

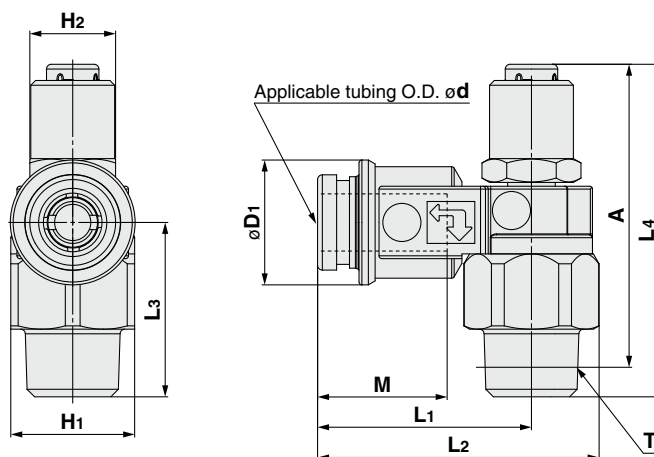

Metric Size

Model	d	T	H1	H2	D1	A	L1	L2	L3	L4	M	Weight [g]				
						Max.				Max.						
ASB22□1-01-06H	6	R1/8	13	9	13.1	35.7	22.5	29.6	18.3	38.7	13.6	21				
ASB22□1-01-08H	8				15.1								25.4	32.5	16.1	24
ASB22□1-02-06H	6	R1/4	17	12	13.1	39.3	24.7	34.0	23.2	44.8	13.6	34				
ASB22□1-02-08H	8				15.1								28.4	37.7	16.1	36
ASB22□1-02-10H	10				18.0								30.8	40.1	17.0	41
ASB32□1-03-08H	8				15.1								30.0	41.9	16.1	70
ASB32□1-03-10H	10	R3/8	22	14	18.0	45.9	32.1	44.0	26.9	51.1	17.0	76				
ASB42□1-04-10H	10				18.0								34.4	48.8	17.0	122
ASB42□1-04-12H	12	R1/2	27	17	21.0	53.1	36.3	50.7	33.5	60.2	18.6	131				
					21.0								36.3	50.7	33.5	60.2

Inch Size

Model	d	T	H1	H2	D1	A	L1	L2	L3	L4	M	Weight [g]				
						Max.				Max.						
ASB22□1-N01-07H	1/4	N1/8	12.7	9	13.1	35.6	22.5	29.6	18.3	38.7	13.5	21				
ASB22□1-N01-09H	5/16				15.1								25.4	32.5	16.1	25
ASB22□1-N02-07H	1/4	N1/4	17.46	12	13.1	37.8	24.7	34.0	23.2	44.8	13.5	35				
ASB22□1-N02-09H	5/16				15.1								28.4	37.7	16.1	38
ASB22□1-N02-11H	3/8				18.0								30.8	40.1	16.6	43
ASB32□1-N03-09H	5/16				15.1								30.0	41.9	16.1	72
ASB32□1-N03-11H	3/8	N3/8	22.23	14	18.0	46.3	32.1	44.0	26.9	51.1	16.6	78				
ASB42□1-N04-11H	3/8				18.0								34.4	48.8	16.6	125
ASB42□1-N04-13H	1/2	N1/2	27	17	21.0	53.1	36.3	50.7	33.5	60.2	18.5	131				
					21.0								36.3	50.7	33.5	60.2

Dimensions

One-touch fitting type
Seal method: Face seal
For G thread

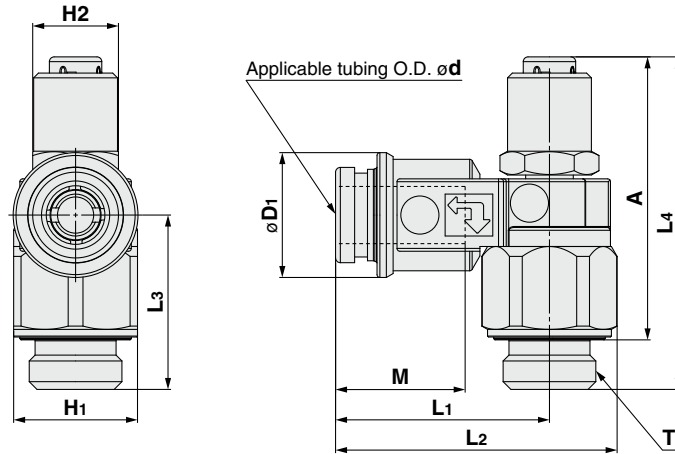

Metric Size

Model	d	T	H1	H2	D1	A	L1	L2	L3	L4	M	Weight [g]				
						Max.				Max.						
ASB22□1-G01-06H	6	G1/8	13	9	13.1	33.2	22.5	29.6	18.3	38.7	13.6	22				
ASB22□1-G01-08H	8				15.1								25.4	32.5	16.1	25
ASB22□1-G02-06H	6	G1/4	17	12	13.1	35.9	24.7	34.0	22	43.6	13.6	36				
ASB22□1-G02-08H	8				15.1								28.4	37.7	16.1	39
ASB22□1-G02-10H	10				18.0								30.8	40.1	17.0	43
ASB32□1-G03-08H	8	G3/8	22	14	15.1	44.0	30.0	41.9	26.9	51.1	16.1	72				
ASB32□1-G03-10H	10				18.0								32.1	44.0	17.0	78
ASB42□1-G04-10H	10	G1/2	27	17	18.0	51.5	34.4	48.8	33.5	60.2	17.0	130				
ASB42□1-G04-12H	12				21.0								36.3	50.7	18.6	139

Related Equipment

Spatter Cover

Applicable tubing: FR soft nylon/TRS, FR double layer/TRB/TRBU, FR three-layer/TRTU



Sales unit: 10 pcs./bag

Model	Applicable tubing O.D.	L1	L2	øD1	øD2
KQB2-06C-X1124	6	24.6	16.6	13.5	11.6
KQB2-08C-X1124	8	30.2	20.6	16.4	14.2
KQB2-10C-X1124	10	34.4	24.6	19.3	16.2

* Since the spatter cover is designed for multi-layer (double layer, three-layer) tubing, sufficient effects cannot be obtained in foreign matter flow-in or followability for single-layer tubing.

* The cover can be attached regardless of the single-layer/multi-layer tubing.

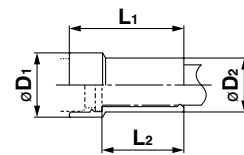

Can also be used for the KQB2/KQG2 series

* Cannot be used for union "Y" (KQBU□/KQG2U) 2-port side



Metal One-touch Fittings
KQB2 Series



Stainless Steel 316 One-touch Fittings
KQG2 Series



ASB-□H Series

Specific Product Precautions 1

Be sure to read this before handling the products. Refer to the back cover for safety instructions. For flow control equipment precautions, refer to the “Handling Precautions for SMC Products” and the “Operation Manual” on the SMC website: <https://www.smcworld.com>

Design and Selection

Warning

1. Confirm the specifications.

The products in this catalog are designed to be used in compressed air systems (including vacuum) only.

If the products are used in an environment where pressure or temperature is out of the specified range, damage and/or malfunction may result. Do not use under such conditions. (Refer to the specifications.)

Please contact SMC when using a fluid other than compressed air (including vacuum).

We do not guarantee against any damage if the product is used outside of the specification range.

2. Products mentioned in this catalog are not designed for use as stop valves with zero air leakage.

A certain amount of leakage is allowed in the product's specifications.

Tightening the needle to reduce leakage to zero may result in equipment damage.

3. Do not disassemble the product or make any modifications, including additional machining.

Doing so may cause human injury and/or an accident.

4. The flow rate characteristics for each product are representative values.

The flow rate characteristics are characteristics of each individual product. Actual values may differ depending on the piping, circuitry, pressure conditions, etc.

Also, depending on product specifications, there may be variations in the zero needle rotations position of the flow rate characteristics.

5. Sonic conductance (C) and critical pressure ratio (b) values for products are representative values.

For controlled flow direction values the needle is fully open. For free flow direction values the needle is fully closed.

6. Check if PTFE can be used in the application.

PTFE powder (Polytetrafluoroethylene resin) is included in the seal material of the male thread type piping taper thread. Confirm that the use of it will not cause any adverse effects on the system.

Please contact SMC if the Safety Data Sheet (SDS) is required.

7. Speed controllers are designed to control the speed of the actuator.

Mounting

Warning

1. Operation manual

Install the product and operate it only after reading the operation manual carefully and understanding its contents.

Also, keep the manual where it can be referred to as necessary.

2. Ensure sufficient space for maintenance activities.

When installing the products, allow access for maintenance and inspection.

3. Tighten threads with the proper tightening torque.

When installing the products, follow the listed torque specifications.

4. Use R external threads with Rc internal threads and NPT external threads with NPT internal threads.

Mounting

Warning

5. Confirm that the lock nut is tightened.

A loose lock nut may cause speed changes in the actuator.

6. Check the degree of rotation of the needle valve.

The products in this catalog are retainer type so that the needle is not removed completely. Over rotation will cause damage.

7. Refer to the table below for the proper adjusting torque of the cap and recommended hexagon wrenches.

Connection thread size	Proper adjusting torque	Recommended hexagon wrench*1
M5, 10-32UNF	0.05	Nominal width across flats 2
1/8	0.17	Nominal width across flats 2
1/4	0.23	Nominal width across flats 2
3/8	0.25	Nominal width across flats 3
1/2	0.4	Nominal width across flats 3

*1 According to the wrench dimension of JIS B 4648 2008 Table 1

8. The number of rotations on the indicator of ASB-□H series uses the upper surface of the fixed lock nut as the reference point.

When checking the number of rotations, make sure to keep the lock nut fixed.

For adjustment, the procedure described below is recommended.

1) Loosen the lock nut for 1/2 rotation.

2) Hold the lock nut by hand or tool, rotate the cap (indication part) with a hexagonal wrench, and adjust the needle opening.

3) Tighten the lock nut.

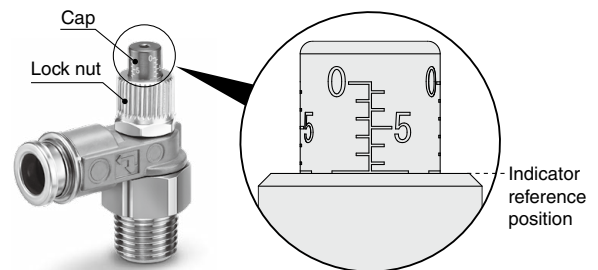

9. See the table below for the maximum number of rotations of the indicator for each size of ASB-□H series.

Excessive rotation above the maximum number of rotations may cause damage.

Connection thread size	Maximum number of rotations of the indicator
M5, 10-32UNF	8 rotations
1/8	10 rotations
1/4	9 rotations
3/8	8 rotations
1/2	10 rotations



ASB-□H Series

Specific Product Precautions 2

Be sure to read this before handling the products. Refer to the back cover for safety instructions. For flow control equipment precautions, refer to the “Handling Precautions for SMC Products” and the “Operation Manual” on the SMC website: <https://www.smcworld.com>

Mounting

Warning

10. Confirm the air flow direction.

Mounting backward is dangerous because the speed adjustment needle will not work, and the actuator may lurch suddenly.

11. Adjust the needle by opening the needle slowly after having closed it completely.

Loose needle valves may cause unexpected sudden actuator extension.

When a needle valve is turned clockwise, it is closed and cylinder speed decreases. When a needle valve is turned counterclockwise, it is open and cylinder speed increases.

Flow Direction Symbols on Body

	Meter-out	Meter-in
Indication symbol		

12. Do not apply excessive force or shock to the body or fittings with an impact tool.

It can cause damage or air leakage.

13. To install/remove the product, use an appropriate wrench to tighten/loosen at the supplied nut on body B.

Do not apply torque at other points, as the product may be damaged. Rotate body A manually for positioning after installation.

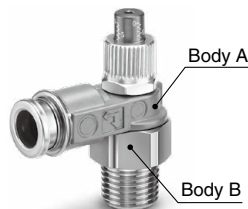

Caution

1. When performing the piping work, turn the tightening tool in the horizontal direction to the hexagon across flats of body B so that any moment is not applied to the body.

If the tool is in contact with the body, this may cause the body to come off.

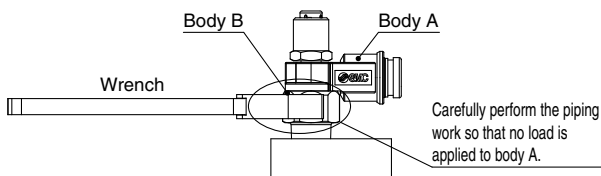

2. Body A can be slightly rotated for positioning, but it cannot be used as a rotating part.

This will cause metal debris by wearing, which may enter the operating fluid or cause fitting damage.

3. If the connection tube oscillates or turns, do not use this product.

Failure to do so may result in fitting breakage or detachment of the body.

Caution

For M5, 10-32UNF

Tightening method

First, tighten it by hand, then give it an additional 1/6 turn to 1/4 turn with a wrench. The reference value for the tightening torque is 1 to 1.5 N·m.

* Excessive tightening may damage the thread portion or deform the gasket and cause air leakage.

If the screw is too shallowly screwed in, it may come loose or air may leak.

Chamfered area for female thread

1. In compliance with ISO 16030 Standards (air pressure fluid dynamics – connection – ports and stud ends), the chamfered thread sizes shown below are recommended.

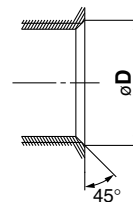

Female thread size	Chamfer dimension øD (Recommended value)
M5	5.1 to 5.4
10-32UNF	5.0 to 5.3

For R, NPT Thread (With sealant)

Tightening method

1. The proper tightening torques of the fittings are as shown in the table below.

As a guide, tighten it by hand, then turn it two or three turns with a wrench.

Check the dimensions of each product for the hexagon width across flats.

Connection thread size	Proper tightening torque [N·m]
NPT, R1/8	3 to 5
NPT, R1/4	8 to 12
NPT, R3/8	15 to 20
NPT, R1/2	20 to 25

Chamfered area for female thread

By chamfering as shown in the following table, machining of threads is easier and effective for burr prevention.

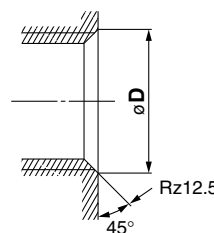

Connection thread size	Chamfer dimension øD (Recommended value)	
	Rc	NPT, NPTF
1/8	10.2 to 10.4	10.5 to 10.7
1/4	13.6 to 13.8	14.1 to 14.3
3/8	17.1 to 17.3	17.4 to 17.6
1/2	21.4 to 21.6	21.7 to 21.9

* For Uni thread, Rz 12.5 is necessary for sealing at the chamfered part.



ASB-□H Series

Specific Product Precautions 3

Be sure to read this before handling the products. Refer to the back cover for safety instructions. For flow control equipment precautions, refer to the “Handling Precautions for SMC Products” and the “Operation Manual” on the SMC website: <https://www.smcworld.com>

Mounting

⚠ Caution

For G Thread (Face seal)

Tightening method

First, tighten the threaded portion by hand, then use a proper wrench, which could be suitable for the width across flats of the hexagon body, to tighten it further at a wrench tightening angle shown in the table below. For a tightening torque guide, refer to the table below. Check the dimensions of each product for the hexagon width across flats.

- 1) The proper tightening torques of the fittings are as shown in the table below.

Connection thread size	Proper tightening torque [N·m]
G1/8	3 to 5
G1/4	8 to 12
G3/8	15 to 20
G1/2	20 to 25

- 2) Insufficient tightening may loosen the threads, or cause air leakage.
- 3) Reuse
 - (1) Normally, fittings with a sealant can be reused up to 6 to 10 times.
 - (2) The seal ring cannot be replaced.

Chamfered area for female thread (Recommended value)

1. Conforming to ISO 16030-2001, the chamfered dimensions shown in the table below are recommended. By chamfering as shown in the table below, machining of threads is easier and effective for burr prevention.

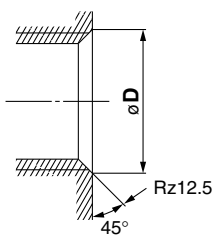

Nominal thread size	Chamfered dimension ϕD	
	Min.	Max.
1/8	9.8	10.2
1/4	13.3	13.7
3/8	16.8	17.2
1/2	21.0	21.4

2. Use G external threads with G internal threads.

How to distinguish between G, R, and NPT threads

For R, NPT threads
R: Without slit
NPT: With slit

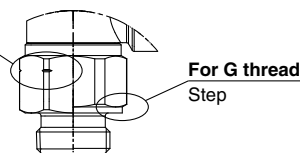

The proper tightening torques for hexagon lock nuts are shown in the table below.

For standard installation, turn 15 to 30° using a tool, after fastening by hand. Pay attention not to over tighten the product. Check the dimensions for each product for the width across flats.

Body size	Proper tightening torque [N·m]	Lock nut width across flats
M5	0.17	7
1/8	0.3	9
1/4	1	12
3/8	1.5	14
1/2	2	17

Piping Threads with Sealant

⚠ Caution

1. If the fitting is tightened with excessive torque, a large amount of sealant will seep out. Remove the excess sealant.
2. Insufficient tightening may loosen the threads or cause air leakage.
3. For reuse
 - 1) Normally, fittings with a sealant can be reused up to 2 to 3 times.
 - 2) To prevent air leakage through the sealant, remove any loose sealant stuck to the fitting by blowing air over the threaded portion.
 - 3) If the sealant no longer provides effective sealing, wind sealant tape over the sealant before reusing. Do not use any form other than the tape type of sealant.
4. Once the fitting has been tightened, backing it out to its original position often causes the sealant to become defective. Air leakage will occur.
5. Use R external threads with Rc internal threads and NPT external threads with NPT internal threads.

Piping

⚠ Caution

1. Refer to the Fittings and Tubing Precautions in the Web Catalog for handling One-touch fittings.
2. Preparation before piping

Before piping is connected, it should be thoroughly blown out with air (flushing) or washed to remove chips, cutting oil, and other debris from inside the pipe.
3. Winding of sealant tape

When screwing piping or fittings into ports, ensure that chips from the pipe threads or sealing material do not enter the piping. Also, if sealant tape is used, leave 1 thread ridge exposed at the end of the threads.

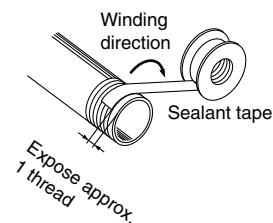

Safety Instructions

These safety instructions are intended to prevent hazardous situations and/or equipment damage. These instructions indicate the level of potential hazard with the labels of “**Caution**,” “**Warning**” or “**Danger**.” They are all important notes for safety and must be followed in addition to International Standards (ISO/IEC)*1), and other safety regulations.

 **Caution:** **Caution** indicates a hazard with a low level of risk which, if not avoided, could result in minor or moderate injury.

 **Warning:** **Warning** indicates a hazard with a medium level of risk which, if not avoided, could result in death or serious injury.

 **Danger :** **Danger** indicates a hazard with a high level of risk which, if not avoided, will result in death or serious injury.

*1) ISO 4414: Pneumatic fluid power – General rules relating to systems.
ISO 4413: Hydraulic fluid power – General rules relating to systems.
IEC 60204-1: Safety of machinery – Electrical equipment of machines.
(Part 1: General requirements)
ISO 10218-1: Manipulating industrial robots – Safety.
etc.

Warning

1. The compatibility of the product is the responsibility of the person who designs the equipment or decides its specifications.

Since the product specified here is used under various operating conditions, its compatibility with specific equipment must be decided by the person who designs the equipment or decides its specifications based on necessary analysis and test results. The expected performance and safety assurance of the equipment will be the responsibility of the person who has determined its compatibility with the product. This person should also continuously review all specifications of the product referring to its latest catalog information, with a view to giving due consideration to any possibility of equipment failure when configuring the equipment.

2. Only personnel with appropriate training should operate machinery and equipment.

The product specified here may become unsafe if handled incorrectly. The assembly, operation and maintenance of machines or equipment including our products must be performed by an operator who is appropriately trained and experienced.

3. Do not service or attempt to remove product and machinery/equipment until safety is confirmed.

1. The inspection and maintenance of machinery/equipment should only be performed after measures to prevent falling or runaway of the driven objects have been confirmed.
2. When the product is to be removed, confirm that the safety measures as mentioned above are implemented and the power from any appropriate source is cut, and read and understand the specific product precautions of all relevant products carefully.
3. Before machinery/equipment is restarted, take measures to prevent unexpected operation and malfunction.

4. Contact SMC beforehand and take special consideration of safety measures if the product is to be used in any of the following conditions.

1. Conditions and environments outside of the given specifications, or use outdoors or in a place exposed to direct sunlight.
2. Installation on equipment in conjunction with atomic energy, railways, air navigation, space, shipping, vehicles, military, medical treatment, combustion and recreation, or equipment in contact with food and beverages, emergency stop circuits, clutch and brake circuits in press applications, safety equipment or other applications unsuitable for the standard specifications described in the product catalog.
3. An application which could have negative effects on people, property, or animals requiring special safety analysis.
4. Use in an interlock circuit, which requires the provision of double interlock for possible failure by using a mechanical protective function, and periodical checks to confirm proper operation.

Caution

1. The product is provided for use in manufacturing industries.

The product herein described is basically provided for peaceful use in manufacturing industries.
If considering using the product in other industries, consult SMC beforehand and exchange specifications or a contract if necessary.
If anything is unclear, contact your nearest sales branch.

Limited warranty and Disclaimer/ Compliance Requirements

The product used is subject to the following “Limited warranty and Disclaimer” and “Compliance Requirements”.

Read and accept them before using the product.

Limited warranty and Disclaimer

1. The warranty period of the product is 1 year in service or 1.5 years after the product is delivered, whichever is first.*2)
Also, the product may have specified durability, running distance or replacement parts. Please consult your nearest sales branch.
2. For any failure or damage reported within the warranty period which is clearly our responsibility, a replacement product or necessary parts will be provided.
This limited warranty applies only to our product independently, and not to any other damage incurred due to the failure of the product.
3. Prior to using SMC products, please read and understand the warranty terms and disclaimers noted in the specified catalog for the particular products.

*2) Vacuum pads are excluded from this 1 year warranty.

A vacuum pad is a consumable part, so it is warranted for a year after it is delivered.
Also, even within the warranty period, the wear of a product due to the use of the vacuum pad or failure due to the deterioration of rubber material are not covered by the limited warranty.

Compliance Requirements

1. The use of SMC products with production equipment for the manufacture of weapons of mass destruction (WMD) or any other weapon is strictly prohibited.
2. The exports of SMC products or technology from one country to another are governed by the relevant security laws and regulations of the countries involved in the transaction. Prior to the shipment of a SMC product to another country, assure that all local rules governing that export are known and followed.

Caution

SMC products are not intended for use as instruments for legal metrology.

Measurement instruments that SMC manufactures or sells have not been qualified by type approval tests relevant to the metrology (measurement) laws of each country. Therefore, SMC products cannot be used for business or certification ordained by the metrology (measurement) laws of each country.

Safety Instructions

Be sure to read the “Handling Precautions for SMC Products” (M-E03-3) and “Operation Manual” before use.

SMC Corporation

Akihabara UDX 15F,
4-14-1, Sotokanda, Chiyoda-ku, Tokyo 101-0021, JAPAN
Phone: 03-5207-8249 Fax: 03-5298-5362
<https://www.smcworld.com>
© 2023 SMC Corporation All Rights Reserved

Specifications are subject to change without prior notice
and any obligation on the part of the manufacturer.