

A detailed 3D rendering of a dark grey industrial motor, shown from a three-quarter perspective. The motor has a complex, rectangular housing with various ports, screws, and a prominent shaft extending from the right side. The entire scene is set against a dark blue background and enclosed within a thin yellow rectangular border.

ACCUDRIVE
SERIES S

Precision. Motion Control. Technology.



Cone Drive is a world leader in precision motion control technology.

We work with our customers every step of the way – from design specs to the final solution – to create highly precise, highly specific products that keep our customers’ technology at the forefront of their industry. Cone Drive offers engineering support, unique solutions, and innovative technology across a breadth of markets and products to drive your company forward.



TABLE OF CONTENTS

ACCUDRIVE SERIES S

PRODUCT RANGE	4
ONLINE CONFIGURATOR	6
DESIGN FEATURES	8
APPLICATIONS	9
UNIT DESIGNATION	10
MOTOR MOUNTING CODES	11
DIMENSIONAL DRAWINGS	12
GENERAL SPECIFICATIONS	14
MOMENT OF INERTIA	15
RATINGS TABLES	16
PRODUCT SELECTION PROCEDURE	28
INSTALLATION, OPERATION, & MAINTENANCE INSTRUCTIONS	30
SAFETY PRECAUTIONS	32

Serving an entire spectrum of mechanical drive applications from food, energy, mining and metal; to automotive, aerospace and marine propulsion, we are your source for drive solutions.

INDUSTRIAL SOLUTIONS

SERIES HP

Worm gearbox with double-enveloping worm gearing. Available in single, double and triple reductions



SERIES HP-A

Universal metric housing featuring double-enveloping gearing & drywell feature



SERIES B

Industrial duty worm gearbox featuring Conex gearing

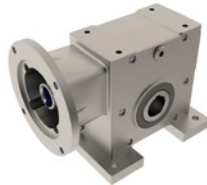

DUO DRIVE

Dual gears on parallel output shafts



SLEWING SOLUTIONS

Versatile slew bearings and slew drives featuring external, internal and without teeth options in a low profile, ready-to-install package



STAINLESS NEMA

Smooth, contoured stainless steel housing (316), IP69K rated, right angle gearbox



DOUBLE-ENVELOPING WORM GEAR SET

Available in standard sizes, ratios and backlash options along with custom worm gear sets



PRECISION MOTION SOLUTIONS

SERIES W

Precision right angle servo gearbox



SERIES RG

Moderate precision right angle servo gearbox

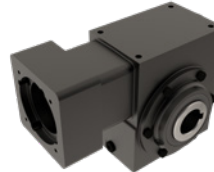

SERIES S

Value engineered right angle servo gearbox

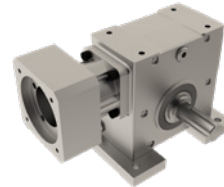

SERIES LE / P

In-line helical geared motors & reducers and precision planetary servo gearbox



HARMONIC

Cone Drive Harmonic Solutions® offer the ultimate in precision motion control technology



STAINLESS SERVO

Smooth, contoured stainless steel housing (316), IP69K rated right angle gearbox



HP SERVO

This double-enveloping worm gearing, high torque gearbox meets the most demanding needs as servo motor capacities increase



We can create custom engineered transmission solutions of any size and configuration.

Design flexibility and lasting performance with our complete family of AccuDrive Precision Products.

SERIES W RIGHT ANGLE GEARHEAD

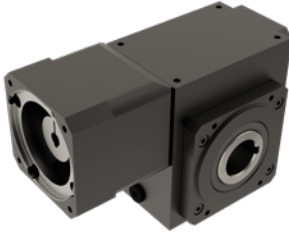

- Output torque capacity up to 10,000 lb.in. (1,130 Nm)
- Solid shaft and Servo motor interfaces standard (NEMA and IEC available upon request)
- Center distance 38 to 89 mm
- IP65 rated
- Input speeds up to 6,000rpm
- Sizes available 38, 51, 64, 76, and 89
- Universal mounting
- Gear ratios from 5:1 to 60:1

SERIES S SERVO GEARHEAD

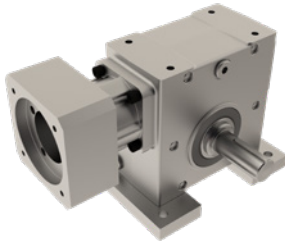

- Economical servo solution
- Output torque up to 7,540 lb.in. (852 Nm)
- Motor adapters to fit servo motors
- Center distance from 1.33 inch up to 3.54 inch
- Speed range up to 4,000 RPM
- Flexible mounting (hollow output standard with plug in solid shaft)
- Ratios from 5:1 to 60:1

SERIES P IN-LINE PLANETARY SERVO GEARHEAD



- Output torque capacity up to 21,240 lb.in. (2,400 Nm)
- Speed range up to 6,000 RPM input
- Sizes available 42, 60, 90, 120, 140, 180, 220 (S-Type)
- Sizes available 60, 75, 100, 140, 180, 210, 240 (P-Type)
- Gear ratios from 3:1 to 100:1 available from stock (S-Type & P-Type)
- Universal Mounting with shaft mount and flange mount standard
- 3 arc-minutes backlash or better

SERIES LE IN-LINE PLANETARY SERVO GEARHEAD



- Output torque capacity up to 7,080 lb.in. (800 Nm)
- Speed range up to 6,000 RPM input
- Sizes 40, 60, 90, 115, 512 and 160 (Series E)
- Gear ratios from 3:1 to 64:1 (Series E)
- Sizes 50, 70, 90, 120, 155, 205, 235 (Series LE)
- Gear ratios from 3:1 to 100:1 (Series LE)
- Universal Mounting with shaft mount and flange mount standard
- Backlash as low as 8 arc-minutes (Series E) and 5 arc-minutes (Series LE)

ABSOLUTE ZERO BACKLASH ACCUDRIVE GEARING



- Unique design captures both sides of the gear tooth to completely eliminate backlash. Automatically compensates for wear-guaranteed zero backlash for the life of the gear. Available for single, double and triple reduction types, gear sets, special designs and the Series W.

Configure Your AccuDrive Online

www.ConeTools.com

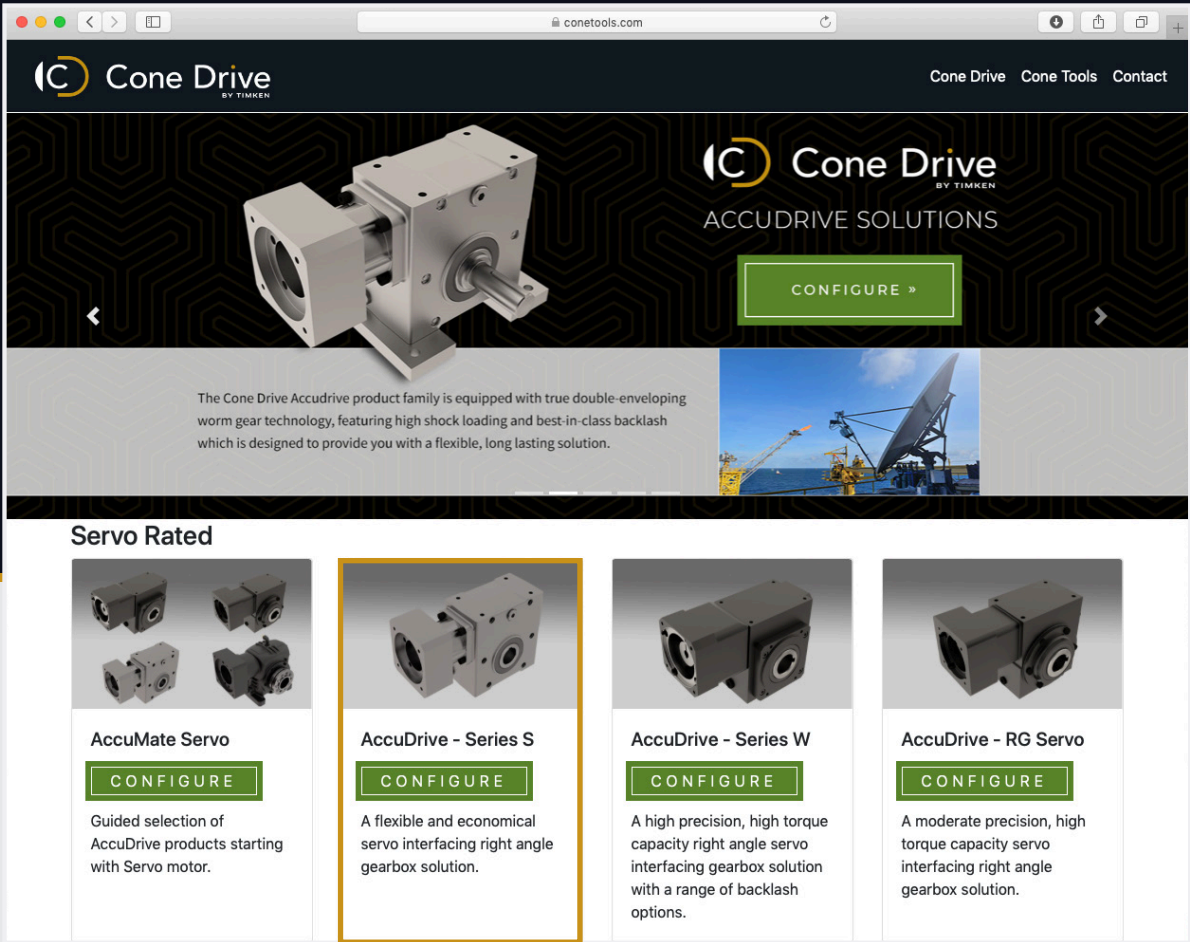

The screenshot shows the Cone Drive website interface. At the top, there's a navigation bar with 'Cone Drive', 'Cone Tools', and 'Contact'. The main banner features a large image of a servo gearhead and the text 'Cone Drive ACCU DRIVE SOLUTIONS' with a 'CONFIGURE »' button. Below the banner, a paragraph describes the product family's features. A 'Servo Rated' section follows, with four product cards: 'AccuMate Servo', 'AccuDrive - Series S' (highlighted with a yellow border), 'AccuDrive - Series W', and 'AccuDrive - RG Servo'. Each card includes a 'CONFIGURE' button and a brief description.



Visit ConeTools.com
and Click
"AccuDrive - Series S"

AccuMate[®]
SERVO GEARHEAD SELECTION PROGRAM

Our AccuMate[®] program helps you select the right servo gearhead for your application.

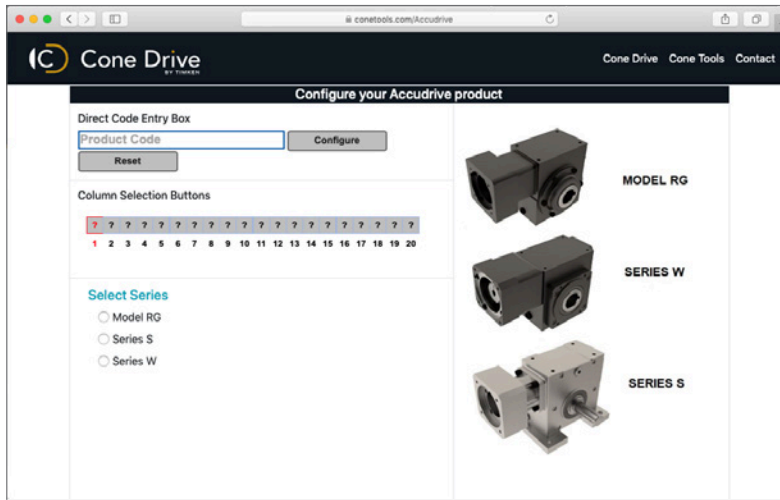

2 Start configuring your AccuDrive product by selecting Series S or entering in the direct code in the entry box

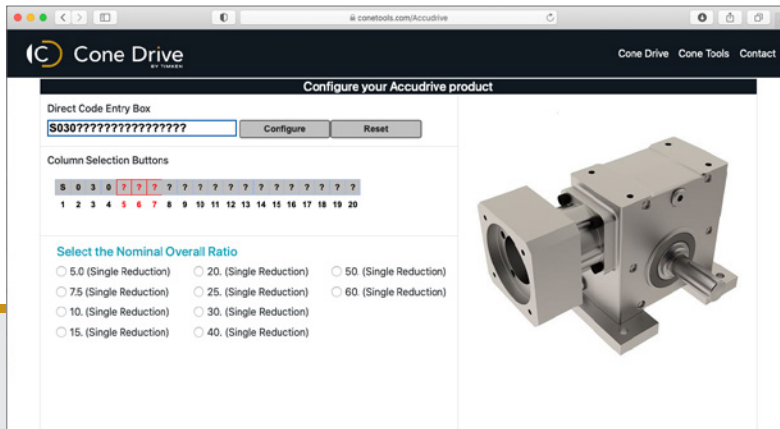

3 Build your unit by selecting criteria specific to your needs

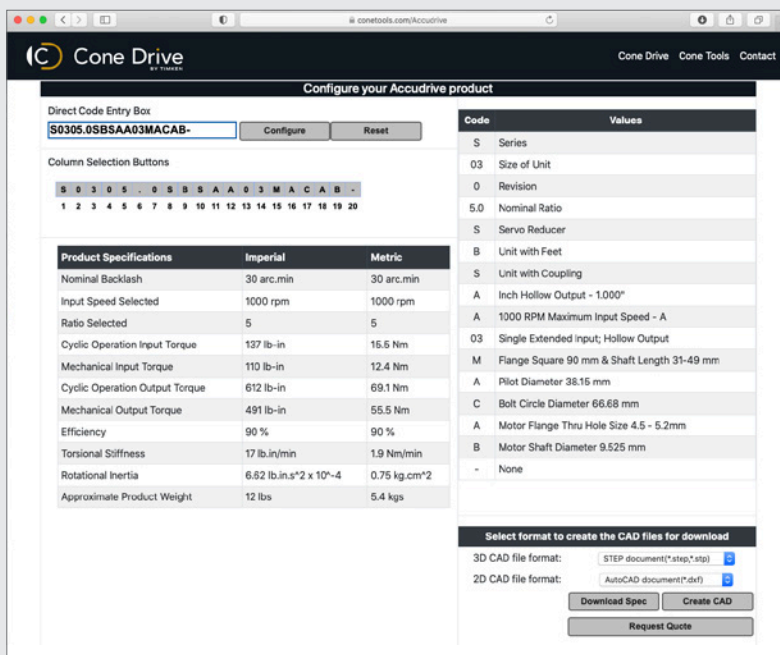

4 On the final screen review the product specifications and click to create a CAD file, download the specs or request a quote

SERIES S RIGHT ANGLE GEARBOX

The Series S is a general purpose, servo rated gearbox featuring a flexible design in an affordable package. Well suited for packaging and general automation, the Cone Drive's Series S was developed to offer you a competitively priced right angle servo solution without sacrificing performance.

Conex Gearing

- Multiple teeth in contact
- Higher load capacity
- Increased durability

Lightweight Aluminum Housing

- Weight savings of up to 30% with improved thermal horsepower over cast iron competition
- IP55 rated with a smooth housing design ideal for washdown applications

Interchangeable, Flexible, & Servo Ready

- Drop in replacement for most U.S. manufactured worm gearboxes
- Filled with synthetic oil and servo motor ready
- Standard with large, hollow bores for easy plugin of the output shaft
- Vent-free design can be mounted in any orientation

Application Assistance

To ensure optimum performance, our Application Engineers can help you design the ideal servo mechanical drive system for your particular application.

We are available to further discuss the Series S design characteristics and help with specifying backlash, gear ratios, and speeds.

Contact us about your application.
TEL: 1-888-994-2663
EMAIL: orders@conedrive.com

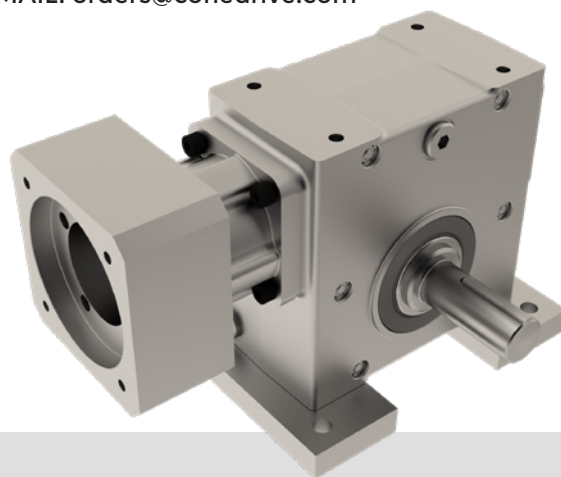

S P E C I F I C A T I O N S

Sizes (Center Distance): 1.33", 1.54", 1.97", 2.38", 3.00", 3.54"

Gear Ratios: 5:1 to 60:1

Input Options: Single extended or double extended

Output Options: Keyed hollow bore or solid shaft

Mounting Options: Universal mounting, base mounted feet

Input Speed: Up to 4,000 rpm

Bearings: Deep groove ball bearings

Gearing: Conex proprietary worm gearing

Shock Load Capacity: 200%

Backlash: Standard backlash

Input Coupling: Zero backlash servo grade coupling

Housing Construction: Aluminum with epoxy coatings available

IP Rating: IP55

Warranty: 2 years



AUTOMATION & ROBOTICS | PACKAGING | SATELLITE COMMUNICATION | CONVEYOR

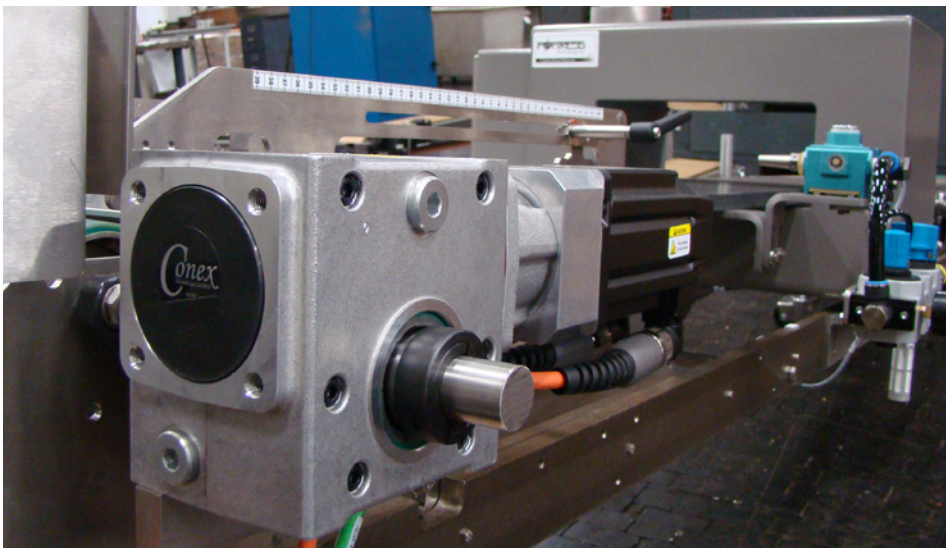

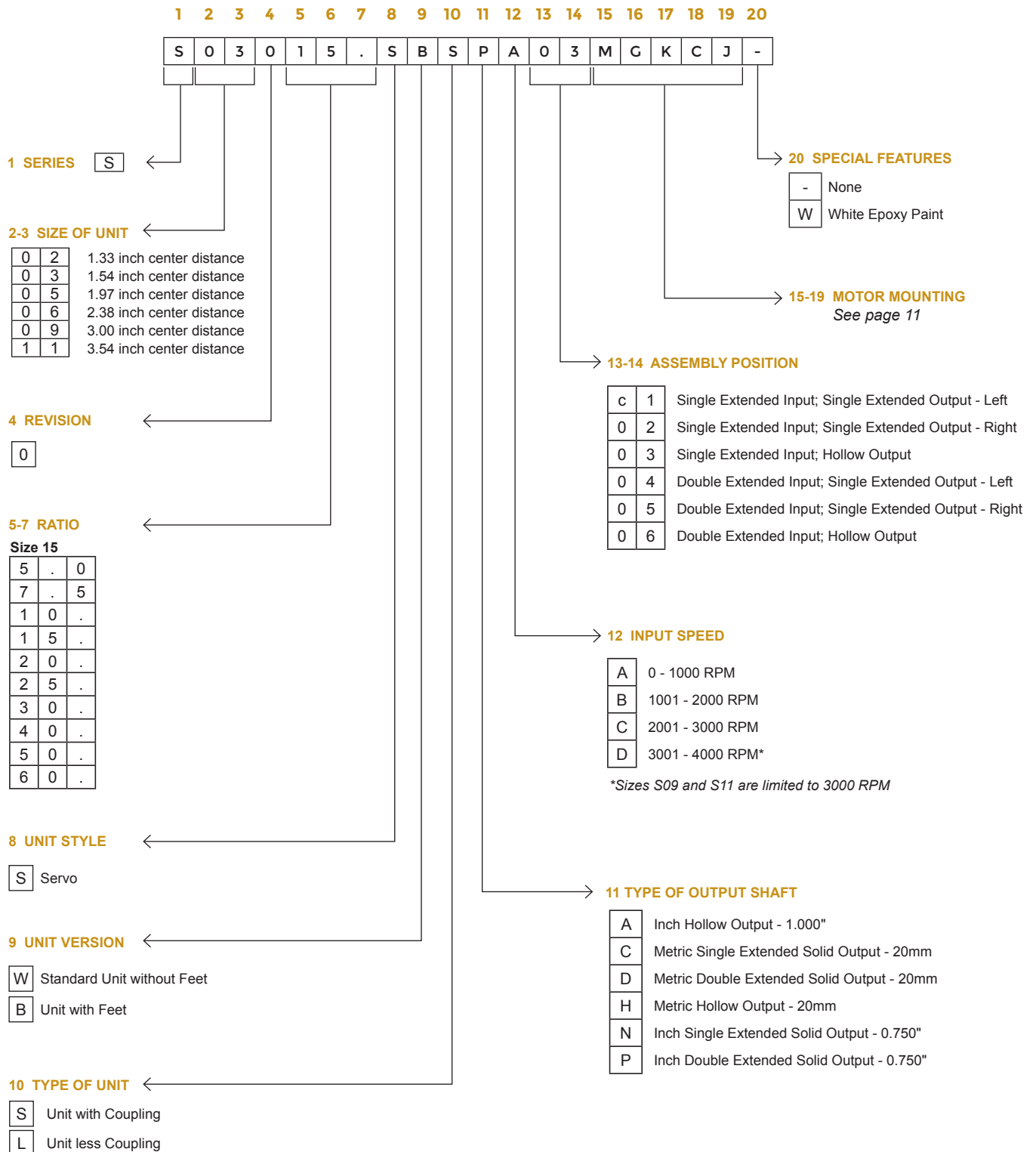

We reserve the right to improve or change product design and specifications without notice.

Servo Motor Flange Selection

1. Go to the appropriate table for the unit size you have selected.
2. Select the appropriate codes for columns 15 - 19 to match the dimensions on your servo motor flange.
3. Make sure your motor length fits the range accommodated by flange square for the size unit you're specifying.
4. If you can't locate the appropriate code for your motor or need assistance, please contact us.

S02, S03, S05, S06

MOTOR FLANGE SQUARE

Column 15	Flange Square (mm)		90			115			130*			140*	
	Acceptable Motor Shaft Length		22-30	31-49	50-65	22-30	31-49	50-65	40-47	48-55	56-73	48-55	56-73
	Unit Size	S02, S03, S05, S06	B	M	Q	C	D	U	E	F	V	G	W

*Not available for S02

MOTOR PILOT DIAMETER

Column 16	Motor Pilot Diameter (mm)											
	38.15	40	50	55.55	60	70	73.07	80	95	110	114.3	130
A	B	C	N	D	E	F	G	H	J	K	L	

BOLT CIRCLE DIAMETER

Column 17	Bolt Circle Diameter (mm)															
	63	65	66.68	70	75	80	85	90	95	98.43	100	115	125.73	130	145	149
A	B	C	D	E	F	U	G	H	J	K	L	T	M	N	P	Q

MOTOR MOUNTING BOLT SIZE

Column 18	Motor Flange Thru Hole Size		4.5 - 5.2		5.3 - 6.3		6.4 - 8.3		8.4 - 10.3		10.4 - 12.4		12.5 - 15.0		
			A		B		C		D		E		F		
	Motor Flange Tapped Holes		M4	M5	M6	M8	M10	M12	1/4 - 20	3/8 - 16	1/2 - 13				
G			H	J	K	L	M	N	P	Q					

MOTOR SHAFT DIAMETER

Column 19	Motor Shaft Diameter (mm)													
	9.525	11	12	12.7	14	15.875	16	19	19.05	22*	22.225*	24*	25.4*	28*
B	D	E	F	G	H	J	K	L	M	N	P	Q	R	

*S06 ONLY

S09, S11

MOTOR FLANGE SQUARE

Column 15	Flange Square (mm)		115		140		190		
	Acceptable Motor Shaft Length		20-32	33-60	38-56	57-80	38-53	54-65	68-85
	Unit Size	S09, S11	C	D	G	H	K	S	T

MOTOR PILOT DIAMETER

Column 16	Motor Pilot Diameter (mm)					
	80	95	110	114.3	130	180
G	H	J	K	L	M	

BOLT CIRCLE DIAMETER

Column 17	Bolt Circle Diameter (mm)						
	100	115	130	145	149.23	165	200
K	L	M	N	P	Q	R	S

MOTOR MOUNTING BOLT SIZE

Column 18	Motor Flange Thru Hole Size		6.4 - 8.3		8.4 - 10.3		10.4 - 12.4		12.5 - 15.0	
			C		D		E		F	
	Motor Flange Tapped Holes		M6	M8	M10	M12	1/4 - 20	3/8 - 16	1/2 - 13	
J			K	L	M	N	P	Q		

MOTOR SHAFT DIAMETER

Column 19	Motor Shaft Diameter (mm)															
	14	15.875	16	19	19.05	22	22.225	24	25.4	28	28.575	31.75	32	34.925	35	38*
G	H	J	K	L	M	N	P	Q	R	S	T	U	V	W	X	Y

*S11 ONLY

Series S Standard Dimensions

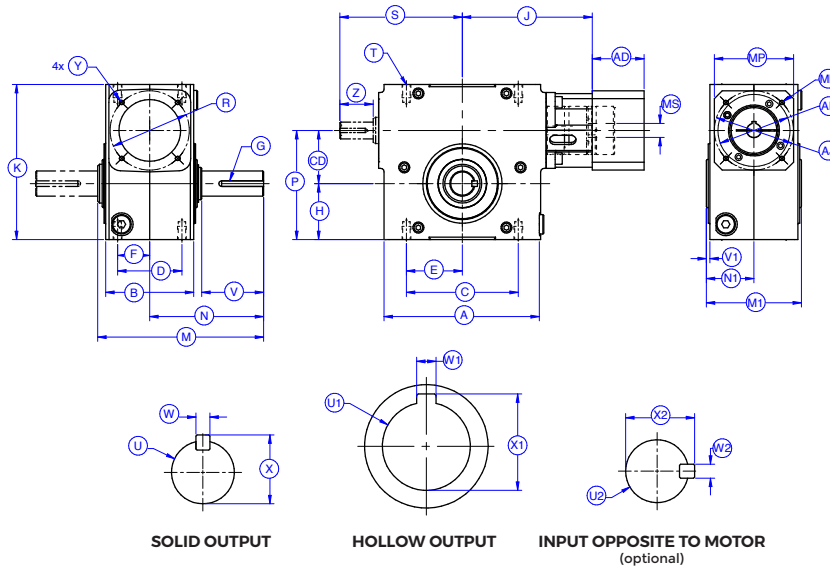

SIZE	CD		A		B		C		D		E		F	
	in	mm	in	mm	in	mm	in	mm	in	mm	in	mm	in	mm
S02	1.33	33.9	4.33	110.0	2.76	70.00	3.25	82.55	2.00	50.80	1.63	41.28	1.00	25.40
S03	1.54	39.1	5.23	133.0	3.94	100.00	4.19	106.43	2.75	69.85	2.09	53.21	1.37	34.92
S05	1.97	50.0	6.00	152.3	3.94	100.00	5.00	127.00	2.87	73.02	2.50	63.50	1.44	36.51
S06	2.38	60.3	7.00	177.8	3.94	100.00	5.00	127.00	2.87	73.02	2.50	63.50	1.44	36.51
S09	3.00	76.2	9.00	228.6	5.12	130.00	7.00	177.80	4.00	101.60	3.50	88.90	2.00	50.80
S11	3.54	90.0	9.50	241.3	5.12	130.00	7.50	190.50	4.00	101.60	3.75	95.25	2.00	50.80

SIZE	G		H		J		K		M		M1 (current)		N			
	in	mm	in	mm	in	mm	in	mm	in	mm	in	mm	in	mm		
S02	3/16 SQ x 1.00		4.76 x 25.4		1.72	43.63	4.95	125.8	4.66	118.4	6.10	155.0	3.85	97.9	4.00	101.6
S03	3/16 SQ x 1.125		4.76 x 28.6		1.91	48.45	4.94	125.4	5.35	136.0	6.61	168.0	4.25	107.9	4.31	109.5
S05	1/4 SQ x 1.500		6.35 x 38.5		2.28	57.85	5.36	136.1	6.38	162.1	7.00	177.8	4.21	107.0	4.69	119.1
S06	1/4 SQ x 1.875		6.35 x 47.6		2.50	63.44	5.79	147.1	6.93	176.0	7.41	188.3	4.25	108.0	5.09	129.3
S09	3/8 SQ x 2.000		9.52 x 51		3.25	82.52	7.25	184.2	8.88	225.6	9.69	246.0	5.43	138.0	6.75	171.5
S11	1/2 SQ x 2.625		12.7 x 66.7		3.38	85.97	7.76	197.2	9.84	250.0	11.34	288.0	6.65	169.0	7.75	196.9

SIZE	N1		P		R		S		T	V		Y	Z	
	in	mm	in	mm	in	mm	in	mm	Thread	in	mm	in	in	mm
S02	1.93	49.0	3.05	77.5	2.51	63.6	4.22	107.3	M8	1.88	47.6	M8	1.31	33.3
S03	2.12	54.0	3.45	87.6	3.56	90.5	4.87	123.7	M8	1.99	50.5	M8	1.48	37.7
S05	2.11	53.5	4.25	107.8	3.56	90.5	5.17	131.2	M10	2.39	60.6	M8	1.48	37.7
S06	2.13	54.0	4.87	123.8	3.56	90.5	5.44	138.2	M10	2.77	70.3	M8	1.48	37.7
S09	2.72	69.0	6.25	158.7	5.01	127.3	7.63	193.7	M12	3.80	96.5	M8	2.69	68.4
S11	3.33	84.5	6.92	175.8	5.01	127.3	8.35	212.0	M16	4.15	105.4	M8	2.95	75.0

SIZE	U2		W2	X2	U		X	V1	U1		X1	W1
	in	Tol	in	in	in	Tol (in)	in	in	in	Tol	in	in
S02	0.6245	± 0.0005	3/16 SQ x 1.00	0.703	0.750	± 0.0005	0.827	0.12	1.0005	± 0.0005	1.088	0.251
S03	0.7495	± 0.0005	3/16 SQ x 1.13	0.828	0.750	± 0.0005	0.827	0.08	1.0005	± 0.0005	1.088	0.251
S05	0.7495	± 0.0005	3/16 SQ x 1.13	0.828	1.125	± 0.0005	1.232	0.08	1.4380	± 0.0005	1.550	0.376
S06	0.7495	± 0.0005	3/16 SQ x 1.13	0.828	1.125	± 0.0005	1.232	0.08	1.4380	± 0.0005	1.550	0.376
S09	1.1870	± 0.0005	1/4 SQ x 2.25	1.296	1.500	± 0.0005	1.660	0.08	2.1880	± 0.0005	2.359	0.501
S11	1.1870	± 0.0005	1/4 SQ x 2.63	1.296	1.875	± 0.0005	2.087	0.10	2.9380	± 0.0005	3.151	0.751

SIZE	Solid Output (Metric)			Hollow Output (Metric)			AD	AJ	AK	MB	MP	MS	WT
	U	X	KEYWAY	U1	X1	W1							
S02	20-19.987	22.5	6 X 28	20 - 20.022	22.9	6	Motor plate dimensions are made to fit your servo motor. Refer to page 11 for available dimensions.						9
S03	20-19.987	22.5	6 X 28	25 - 25.022	28.5	8							14
S05	25 - 24.987	29.0	8 X 36	35 - 35.026	38.5	10							19
S06	30 - 29.987	34.0	8 X 50	35 - 35.026	38.5	10							25
S09	35 - 34.984	40.0	10 X 50	55 - 55.026	59.5	16							52
S11	42 - 41.984	49.0	12 X 70	75 - 75.026	80.1	20							82

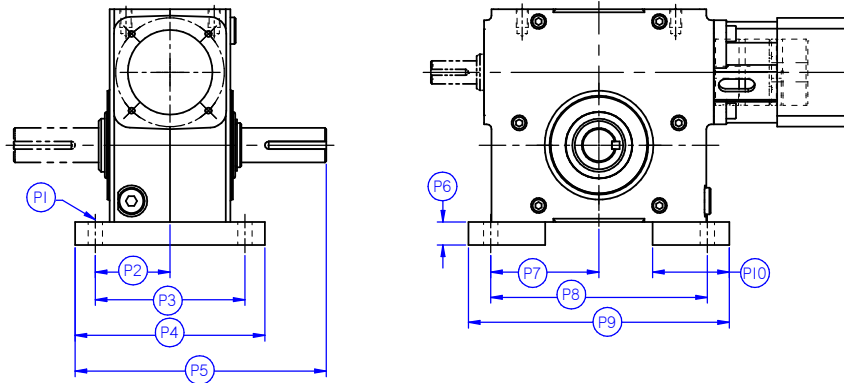

SIZE	P1	P2		P3		P4		P5	
	mm	in	mm	in	mm	in	mm	in	mm
S02	M8	1.66	42.0	3.31	84.1	4.19	106.4	6.10	154.8
S03	M8	2.16	54.8	4.31	109.5	5.44	138.2	7.03	178.6
S05	M10	2.34	59.5	4.69	119.1	5.94	150.9	7.66	194.6
S06	M10	2.44	61.9	4.88	123.8	6.18	157.0	8.18	207.8
S09	M12	2.94	74.6	5.88	149.2	7.50	190.5	10.50	266.7
S11	M16	3.06	77.8	6.13	155.6	7.70	195.6	11.60	294.6

SIZE	P6		P7		P8		P9		P10	
	in	mm	in	mm	in	mm	in	mm	in	mm
S02	0.53	13.5	2.19	55.6	4.38	111.3	5.38	136.7	1.50	38.1
S03	0.59	15.0	2.63	66.7	5.25	133.4	6.44	163.6	1.50	38.1
S05	0.72	18.3	3.19	81.0	6.38	162.1	7.75	196.9	2.00	50.8
S06	0.75	19.1	3.53	89.7	7.06	179.3	8.50	215.9	2.50	63.5
S09	0.75	19.1	4.22	107.2	8.44	214.4	10.00	254.0	2.00	50.8
S11	1.61	40.9	4.75	120.7	9.50	241.3	11.08	281.4	2.50	63.5

		SIZE						
		S02	S03	S05	S06	S09	S11	
Emergency Stop	T_{2MAX} (see expanded rating tables)							
Maximum Overhung Load ¹	lb-in	400	475	975	1100	1550	2200	
	N	1780	2110	4330	4890	6890	9780	
Operating Temperature	°F	(-13 to +200)						
	°C	(-25 to +100)						
Degree of Protection	IP 55							
Lubrication	Synthetic Gear Oil -- Factory Filled							
Mounting Position	Any							
Weight (Hollow Shaft Unit; Filled with Oil)	lb	7	12	16	22	44	65	
	kg	3.2	5.4	7.3	10	20	29.5	
Nominal Backlash	Low	arcmin	41	30	23	20	15	12
Torsional Rigidity	lb-in/min	8.6	17	27	50	137	251	
	Nm/min	1.0	1.9	3.1	5.6	15.5	28.4	

1 Applied at center of output keyway.

Ratios 30:1 and above can be self-locking. It is important to review the input torque applied during stopping and reversing. This is of particular importance when unrestrained high inertia loads are involved.

	RATIO	UNITS	SIZE					
			S02	S03	S05	S06	S09	S11
Moment of Inertia ¹	5	lb.in. s ² 10 ⁻⁴	3.18	6.62	16.18	23.11	109.44	224.31
		kg cm ²	0.36	0.75	1.83	2.61	12.36	25.34
	7.5	lb.in. s ² 10 ⁻⁴	2.90	5.69	13.73	17.84	93.05	175.47
		kg cm ²	0.33	0.64	1.55	2.02	10.51	19.82
	10	lb.in. s ² 10 ⁻⁴	2.80	5.36	12.87	15.99	87.32	158.38
		kg cm ²	0.32	0.61	1.45	1.81	9.87	17.89
	15	lb.in. s ² 10 ⁻⁴	2.73	5.13	12.26	14.67	83.22	146.17
		kg cm ²	0.31	0.58	1.39	1.66	9.40	16.51
	20	lb.in. S ² 10 ⁻⁴	2.71	5.05	12.05	14.21	81.79	141.90
		kg cm ²	0.31	0.57	1.36	1.61	9.24	16.03
	25	lb.in. s ² 10 ⁻⁴	2.69	5.01	11.95	14.00	81.12	139.92
		kg cm ²	0.30	0.57	1.35	1.58	9.17	15.81
	30	lb.in. s ² 10 ⁻⁴	2.69	4.99	11.89	13.88	80.76	138.84
		kg cm ²	0.30	0.56	1.34	1.57	9.12	15.69
	40	lb.in. s ² 10 ⁻⁴	2.68	4.97	11.84	13.77	80.41	137.78
		kg cm ²	0.30	0.56	1.34	1.56	9.08	15.57
	50	lb.in. s ² 10 ⁻⁴	2.68	4.96	11.82	13.71	80.24	137.28
		kg cm ²	0.30	0.56	1.33	1.55	9.07	15.51
	60	lb.in. s ² 10 ⁻⁴	2.68	4.95	11.80	13.68	80.15	137.01
		kg cm ²	0.30	0.56	1.33	1.55	9.06	15.48

1 The moment of inertia values reflected at the input shaft and includes coupling

S02

i : 1	Ratings	Units	$N_{1,NOM}$ (rpm)				$N_{1,PK}$ rpm	$T_{2,MAX}$		
			500	1,000	2,000	3,000		4,000	lb-in	Nm
5	$P_{1,ME}$	hp	0.76	1.22	1.93	2.51	3.02	3000	949	107
		kW	0.57	0.91	1.44	1.87	2.25			
	$P_{1,TH}$	hp	0.76	1.09	0.57	*	*			
		kW	0.57	0.81	0.43	*	*			
	$T_{2,ME}$	lb-in	419	336	261	220	193			
		Nm	47	38	29	25	22			
$T_{2,ACC}$	lb-in	474	419	336	291	261				
	Nm	54	47	38	33	29				
η	%	87	88	86	84	81				
7.5	$P_{1,ME}$	hp	0.55	0.89	1.43	1.89	2.31	3000	1,052	119
		kW	0.41	0.66	1.07	1.41	1.72			
	$P_{1,TH}$	hp	0.55	0.89	0.58	*	*			
		kW	0.41	0.66	0.43	*	*			
	$T_{2,ME}$	lb-in	438	356	282	241	214			
		Nm	49	40	32	27	24			
$T_{2,ACC}$	lb-in	526	438	356	312	282				
	Nm	59	49	40	35	32				
η	%	84	85	83	81	78				
10	$P_{1,ME}$	hp	0.34	0.68	1.16	1.55	1.91	3000	700	79
		kW	0.25	0.51	0.86	1.15	1.42			
	$P_{1,TH}$	hp	0.34	0.68	0.55	*	*			
		kW	0.25	0.51	0.41	*	*			
	$T_{2,ME}$	lb-in	353	354	295	255	228			
		Nm	40	40	33	29	26			
$T_{2,ACC}$	lb-in	357	360	359	324	295				
	Nm	40	41	41	37	33				
η	%	82	83	81	78	76				
15	$P_{1,ME}$	hp	0.29	0.52	0.87	1.18	1.47	3000	832	94
		kW	0.22	0.39	0.65	0.88	1.10			
	$P_{1,TH}$	hp	0.29	0.52	0.46	*	*			
		kW	0.22	0.39	0.34	*	*			
	$T_{2,ME}$	lb-in	420	384	311	272	245			
		Nm	47	43	35	31	28			
$T_{2,ACC}$	lb-in	423	427	384	341	311				
	Nm	48	48	43	38	35				
η	%	77	78	76	73	70				
20	$P_{1,ME}$	hp	0.25	0.41	0.69	0.95	1.20	3000	1,017	115
		kW	0.19	0.31	0.52	0.71	0.89			
	$P_{1,TH}$	hp	0.25	0.41	0.38	*	*			
		kW	0.19	0.31	0.28	*	*			
	$T_{2,ME}$	lb-in	449	374	306	269	244			
		Nm	51	42	35	30	28			
$T_{2,ACC}$	lb-in	509	449	374	334	306				
	Nm	57	51	42	38	35				
η	%	71	72	70	67	65				

Maximum input speed allowed for short acceleration cycles. See page 29 for rating definitions.

S02

i : 1	Ratings	Units	$N_{1,NOM}$ (rpm)					$N_{1,PK}$ rpm	$T_{2,MAX}$	
			500	1,000	2,000	3,000	4,000		lb-in	Nm
25	$P_{1,ME}$	hp	0.23	0.37	0.63	0.86	1.09	3000	1,071	121
		kW	0.17	0.28	0.47	0.64	0.82			
	$P_{1,TH}$	hp	0.23	0.37	0.34	*	*			
		kW	0.17	0.28	0.25	*	*			
	$T_{2,ME}$	lb-in	475	398	327	289	263			
		Nm	54	45	37	33	30			
	$T_{2,ACC}$	lb-in	501	475	398	356	327			
		Nm	57	54	45	40	37			
	η	%	67	68	66	64	61			
	30	$P_{1,ME}$	hp	0.19	0.32	0.54	0.75			
kW			0.14	0.24	0.40	0.56	0.72			
$P_{1,TH}$		hp	0.19	0.32	0.31	*	*			
		kW	0.14	0.24	0.23	*	*			
$T_{2,ME}$		lb-in	452	387	319	283	258			
		Nm	51	44	36	32	29			
$T_{2,ACC}$		lb-in	454	457	387	347	319			
		Nm	51	52	44	39	36			
η		%	63	65	63	60	57			
40		$P_{1,ME}$	hp	0.15	0.24	0.42	0.60	0.77	3000	953
	kW		0.11	0.18	0.31	0.45	0.58			
	$P_{1,TH}$	hp	0.15	0.24	0.27	*	*			
		kW	0.11	0.18	0.20	*	*			
	$T_{2,ME}$	lb-in	408	345	287	255	234			
		Nm	46	39	32	29	26			
	$T_{2,ACC}$	lb-in	477	408	345	311	287			
		Nm	54	46	39	35	32			
	η	%	55	56	54	51	48			
	50	$P_{1,ME}$	hp	0.13	0.21	0.37	0.53	0.69		
kW			0.09	0.16	0.28	0.40	0.52			
$P_{1,TH}$		hp	0.13	0.21	0.24	*	*			
		kW	0.09	0.16	0.18	*	*			
$T_{2,ME}$		lb-in	397	337	281	251	230			
		Nm	45	38	32	28	26			
$T_{2,ACC}$		lb-in	446	397	337	304	281			
		Nm	50	45	38	34	32			
η		%	50	50	48	45	42			
60		$P_{1,ME}$	hp	0.11	0.18	0.33	0.47	0.62	3000	750
	kW		0.08	0.14	0.24	0.35	0.46			
	$P_{1,TH}$	hp	0.11	0.18	0.22	*	*			
		kW	0.08	0.14	0.17	*	*			
	$T_{2,ME}$	lb-in	350	314	263	235	216			
		Nm	40	35	30	27	24			
	$T_{2,ACC}$	lb-in	375	350	314	283	263			
		Nm	42	40	35	32	30			
	η	%	44	45	42	39	37			

Maximum input speed allowed for short acceleration cycles. See page 29 for rating definitions.

S03

i : 1	Ratings	Units	$N_{1,NOM}$ (rpm)				$N_{1,PK}$ rpm	$T_{2,MAX}$		
			500	1,000	2,000	3,000		4,000	lb-in	Nm
5	$P_{1,ME}$	hp	1.10	1.75	2.75	3.55	4.24	3000	1,358	153
		kW	0.82	1.31	2.05	2.65	3.16			
	$P_{1,TH}$	hp	1.10	1.48	1.03	*	*			
		kW	0.82	1.10	0.77	*	*			
	$T_{2,ME}$	lb-in	612	491	381	322	282			
		Nm	69	56	43	36	32			
$T_{2,ACC}$	lb-in	692	612	491	425	381				
	Nm	78	69	56	48	43				
η	%	88	89	88	86	84				
7.5	$P_{1,ME}$	hp	0.79	1.27	2.03	2.67	3.23	3000	1,543	174
		kW	0.59	0.95	1.52	1.99	2.40			
	$P_{1,TH}$	hp	0.79	1.24	0.96	*	*			
		kW	0.59	0.92	0.71	*	*			
	$T_{2,ME}$	lb-in	641	522	412	353	313			
		Nm	72	59	47	40	35			
$T_{2,ACC}$	lb-in	772	641	522	456	412				
	Nm	87	72	59	52	47				
η	%	86	87	86	84	82				
10	$P_{1,ME}$	hp	0.43	0.85	1.62	2.14	2.62	3000	893	101
		kW	0.32	0.63	1.21	1.60	1.95			
	$P_{1,TH}$	hp	0.43	0.85	0.88	*	*			
		kW	0.32	0.63	0.66	*	*			
	$T_{2,ME}$	lb-in	452	455	427	369	330			
		Nm	51	51	48	42	37			
$T_{2,ACC}$	lb-in	455	460	461	458	427				
	Nm	51	52	52	52	48				
η	%	84	85	84	82	80				
15	$P_{1,ME}$	hp	0.36	0.71	1.22	1.64	2.03	3000	1,066	120
		kW	0.27	0.53	0.91	1.22	1.51			
	$P_{1,TH}$	hp	0.36	0.71	0.70	*	*			
		kW	0.27	0.53	0.52	*	*			
	$T_{2,ME}$	lb-in	539	543	459	401	362			
		Nm	61	61	52	45	41			
$T_{2,ACC}$	lb-in	542	548	549	503	459				
	Nm	61	62	62	57	52				
η	%	79	80	79	78	76				
20	$P_{1,ME}$	hp	0.36	0.59	0.97	1.31	1.64	3000	1,581	179
		kW	0.27	0.44	0.72	0.98	1.22			
	$P_{1,TH}$	hp	0.36	0.59	0.57	*	*			
		kW	0.27	0.44	0.43	*	*			
	$T_{2,ME}$	lb-in	670	559	457	401	364			
		Nm	76	63	52	45	41			
$T_{2,ACC}$	lb-in	791	670	559	498	457				
	Nm	89	76	63	56	52				
η	%	74	75	75	73	70				

Maximum input speed allowed for short acceleration cycles. See page 29 for rating definitions.

S03

i : 1	Ratings	Units	$N_{1,NOM}$ (rpm)					$N_{1,PK}$ rpm	$T_{2,MAX}$	
			500	1,000	2,000	3,000	4,000		lb-in	Nm
25	$P_{1,ME}$	hp	0.29	0.53	0.87	1.19	1.49	3000	1,358	153
		kW	0.22	0.39	0.65	0.89	1.11			
	$P_{1,TH}$	hp	0.29	0.53	0.49	*	*			
		kW	0.22	0.39	0.37	*	*			
	$T_{2,ME}$	lb-in	635	596	490	432	393			
		Nm	72	67	55	49	44			
	$T_{2,ACC}$	lb-in	637	642	596	533	490			
		Nm	72	73	67	60	55			
	η	%	70	72	71	69	67			
	30	$P_{1,ME}$	hp	0.23	0.45	0.74	1.02			
kW			0.17	0.33	0.55	0.76	0.96			
$P_{1,TH}$		hp	0.23	0.45	0.46	*	*			
		kW	0.17	0.33	0.34	*	*			
$T_{2,ME}$		lb-in	583	576	476	421	384			
		Nm	66	65	54	48	43			
$T_{2,ACC}$		lb-in	585	589	576	516	476			
		Nm	66	67	65	58	54			
η		%	67	68	68	66	63			
40		$P_{1,ME}$	hp	0.21	0.34	0.57	0.79	1.01	3000	1,423
	kW		0.15	0.25	0.43	0.59	0.75			
	$P_{1,TH}$	hp	0.21	0.34	0.38	*	*			
		kW	0.15	0.25	0.28	*	*			
	$T_{2,ME}$	lb-in	610	515	428	380	348			
		Nm	69	58	48	43	39			
	$T_{2,ACC}$	lb-in	712	610	515	463	428			
		Nm	80	69	58	52	48			
	η	%	59	61	60	57	55			
	50	$P_{1,ME}$	hp	0.18	0.29	0.49	0.69	0.89		
kW			0.13	0.22	0.37	0.51	0.66			
$P_{1,TH}$		hp	0.18	0.29	0.33	*	*			
		kW	0.13	0.22	0.25	*	*			
$T_{2,ME}$		lb-in	591	501	418	373	342			
		Nm	67	57	47	42	39			
$T_{2,ACC}$		lb-in	688	591	501	452	418			
		Nm	78	67	57	51	47			
η		%	53	55	54	51	49			
60		$P_{1,ME}$	hp	0.15	0.25	0.43	0.60	0.78	3000	1,176
	kW		0.11	0.19	0.32	0.45	0.58			
	$P_{1,TH}$	hp	0.15	0.25	0.30	*	*			
		kW	0.11	0.19	0.23	*	*			
	$T_{2,ME}$	lb-in	548	465	389	348	320			
		Nm	62	53	44	39	36			
	$T_{2,ACC}$	lb-in	588	548	465	420	389			
		Nm	66	62	53	47	44			
	η	%	48	50	48	46	43			

Maximum input speed allowed for short acceleration cycles. See page 29 for rating definitions.

S05

i : 1	Ratings	Units	N_{1NOM} (rpm)					N_{1PK} rpm	T_{2MAX}	
			500	1,000	2,000	3,000	4,000		lb-in	Nm
5	P_{1ME}	hp	2.04	3.24	5.04	6.45	7.64	4000	2,673	302
		kW	1.52	2.41	3.76	4.81	5.69			
	P_{1TH}	hp	2.02	2.19	2.15	0.50	*			
		kW	1.51	1.63	1.60	0.37	*			
	T_{2ME}	lb-in	1,158	927	718	605	530			
		Nm	131	105	81	68	60			
	T_{2ACC}	lb-in	1,362	1,158	927	802	718			
		Nm	154	131	105	91	81			
η	%	90	91	90	89	88				
7.5	P_{1ME}	hp	1.46	2.34	3.71	4.81	5.77	4000	2,928	331
		kW	1.09	1.75	2.77	3.59	4.30			
	P_{1TH}	hp	1.46	1.83	1.89	0.68	*			
		kW	1.09	1.36	1.41	0.51	*			
	T_{2ME}	lb-in	1,216	987	779	667	591			
		Nm	137	112	88	75	67			
	T_{2ACC}	lb-in	1,464	1,216	987	863	779			
		Nm	165	137	112	98	88			
η	%	88	89	89	88	87				
10	P_{1ME}	hp	0.80	1.60	2.88	3.78	4.57	4000	1,722	195
		kW	0.60	1.19	2.15	2.82	3.40			
	P_{1TH}	hp	0.80	1.60	1.71	0.71	*			
		kW	0.60	1.19	1.27	0.53	*			
	T_{2ME}	lb-in	873	881	793	684	612			
		Nm	99	100	90	77	69			
	T_{2ACC}	lb-in	877	888	892	873	793			
		Nm	99	100	101	99	90			
η	%	86	87	87	86	85				
15	P_{1ME}	hp	0.68	1.33	2.22	2.93	3.58	4000	2,066	233
		kW	0.50	0.99	1.65	2.19	2.67			
	P_{1TH}	hp	0.68	1.21	1.32	0.63	*			
		kW	0.50	0.90	0.98	0.47	*			
	T_{2ME}	lb-in	1,047	1,057	881	768	693			
		Nm	118	119	100	87	78			
	T_{2ACC}	lb-in	1,051	1,064	1,069	964	881			
		Nm	119	120	121	109	100			
η	%	82	84	84	83	82				
20	P_{1ME}	hp	0.67	1.09	1.76	2.35	2.88	4000	3,093	349
		kW	0.50	0.81	1.32	1.75	2.15			
	P_{1TH}	hp	0.67	0.95	1.04	0.55	*			
		kW	0.50	0.71	0.78	0.41	*			
	T_{2ME}	lb-in	1,309	1,091	890	781	707			
		Nm	148	123	101	88	80			
	T_{2ACC}	lb-in	1,546	1,309	1,091	971	890			
		Nm	175	148	123	110	101			
η	%	77	80	80	79	78				

Maximum input speed allowed for short acceleration cycles. See page 29 for rating definitions.

S05

i : 1	Ratings	Units	N_{1NOM} (rpm)					N_{1PK} rpm	T_{2MAX}	
			500	1,000	2,000	3,000	4,000		lb-in	Nm
25	P_{1ME}	hp	0.52	0.97	1.58	2.11	2.60	4000	2,598	293
		kW	0.39	0.73	1.18	1.58	1.94			
	P_{1TH}	hp	0.52	0.80	0.89	0.49	*			
		kW	0.39	0.60	0.66	0.37	*			
	T_{2ME}	lb-in	1,216	1,172	962	847	770			
		Nm	137	132	109	96	87			
T_{2ACC}	lb-in	1,218	1,228	1,172	1,047	962				
	Nm	138	139	132	118	109				
η	%	74	76	77	76	75				
30	P_{1ME}	hp	0.46	0.81	1.32	1.77	2.19	4000	2,442	276
		kW	0.34	0.60	0.98	1.32	1.63			
	P_{1TH}	hp	0.46	0.73	0.81	0.46	*			
		kW	0.34	0.54	0.60	0.35	*			
	T_{2ME}	lb-in	1,235	1,122	925	818	745			
		Nm	140	127	104	92	84			
T_{2ACC}	lb-in	1,138	1,146	1,122	1,004	925				
	Nm	129	130	127	113	104				
η	%	71	73	74	73	72				
40	P_{1ME}	hp	0.37	0.60	0.99	1.33	1.66	4000	2,785	315
		kW	0.28	0.45	0.74	1.00	1.24			
	P_{1TH}	hp	0.37	0.58	0.65	0.40	*			
		kW	0.28	0.43	0.48	0.30	*			
	T_{2ME}	lb-in	1,191	1,005	834	740	677			
		Nm	135	114	94	84	76			
T_{2ACC}	lb-in	1,392	1,191	1,005	903	834				
	Nm	157	135	114	102	94				
η	%	63	66	67	66	65				
50	P_{1ME}	hp	0.31	0.50	0.83	1.13	1.41	4000	2,653	300
		kW	0.23	0.37	0.62	0.84	1.05			
	P_{1TH}	hp	0.31	0.50	0.56	0.37	*			
		kW	0.23	0.37	0.42	0.27	*			
	T_{2ME}	lb-in	1,138	963	803	715	655			
		Nm	129	109	91	81	74			
T_{2ACC}	lb-in	1,327	1,138	963	868	803				
	Nm	150	129	109	98	91				
η	%	58	61	62	60	59				
60	P_{1ME}	hp	0.27	0.43	0.71	0.97	1.22	4000	2,473	279
		kW	0.20	0.32	0.53	0.72	0.91			
	P_{1TH}	hp	0.27	0.43	0.50	0.34	*			
		kW	0.20	0.32	0.38	0.26	*			
	T_{2ME}	lb-in	1,063	903	754	673	618			
		Nm	120	102	85	76	70			
T_{2ACC}	lb-in	1,237	1,063	903	814	754				
	Nm	140	120	102	92	85				
η	%	53	56	56	55	54				

Maximum input speed allowed for short acceleration cycles. See page 29 for rating definitions.

S06

i : 1	Ratings	Units	N_{1NOM} (rpm)				N_{1PK} rpm	T_{2MAX}		
			500	1,000	2,000	3,000		4,000	lb-in	Nm
5	P_{1ME}	hp	3.32	5.26	8.14	10.37	12.22	4000	4,602	520
		kW	2.48	3.92	6.07	7.74	9.12			
	P_{1TH}	hp	2.74	3.04	3.49	1.78	*			
		kW	2.04	2.26	2.60	1.32	*			
	T_{2ME}	lb-in	1,904	1,523	1,178	992	868			
		Nm	215	172	133	112	98			
T_{2ACC}	lb-in	2,319	1,904	1,523	1,317	1,178				
	Nm	262	215	172	149	133				
η	%	91	92	92	91	90				
7.5	P_{1ME}	hp	2.36	3.78	5.95	7.68	9.16	4000	4,800	542
		kW	1.76	2.82	4.44	5.73	6.83			
	P_{1TH}	hp	2.29	2.56	3.04	1.77	*			
		kW	1.71	1.91	2.27	1.32	*			
	T_{2ME}	lb-in	1,991	1,615	1,273	1,089	965			
		Nm	225	182	144	123	109			
T_{2ACC}	lb-in	2,400	1,991	1,615	1,411	1,273				
	Nm	271	225	182	159	144				
η	%	89	90	91	90	89				
10	P_{1ME}	hp	1.22	2.43	4.56	5.94	7.15	4000	2,660	301
		kW	0.91	1.81	3.40	4.43	5.33			
	P_{1TH}	hp	1.22	2.43	2.71	1.66	*			
		kW	0.91	1.81	2.02	1.24	*			
	T_{2ME}	lb-in	1,350	1,364	1,282	1,106	988			
		Nm	153	154	145	125	112			
T_{2ACC}	lb-in	1,355	1,371	1,379	1,378	1,282				
	Nm	153	155	156	156	145				
η	%	88	89	89	89	88				
15	P_{1ME}	hp	1.03	2.02	3.57	4.69	5.69	4000	3,203	362
		kW	0.77	1.51	2.66	3.50	4.24			
	P_{1TH}	hp	1.03	1.69	2.06	1.35	*			
		kW	0.77	1.26	1.54	1.00	*			
	T_{2ME}	lb-in	1,625	1,642	1,460	1,273	1,147			
		Nm	184	186	165	144	130			
T_{2ACC}	lb-in	1,630	1,649	1,659	1,600	1,460				
	Nm	184	186	187	181	165				
η	%	84	86	86	86	85				
20	P_{1ME}	hp	1.10	1.77	2.85	3.76	4.58	4000	5,196	587
		kW	0.82	1.32	2.12	2.80	3.41			
	P_{1TH}	hp	1.10	1.32	1.62	1.09	*			
		kW	0.82	0.98	1.21	0.82	*			
	T_{2ME}	lb-in	2,198	1,829	1,491	1,307	1,183			
		Nm	248	207	168	148	134			
T_{2ACC}	lb-in	2,598	2,198	1,829	1,627	1,491				
	Nm	294	248	207	184	168				
η	%	79	82	83	83	82				

Maximum input speed allowed for short acceleration cycles. See page 29 for rating definitions.

S06

i : 1	Ratings	Units	N_{1NOM} (rpm)				N_{1PK} rpm	T_{2MAX}		
			500	1,000	2,000	3,000		4,000	lb-in	Nm
25	P_{1ME}	hp	0.80	1.55	2.55	3.38	4.12	4000	4,095	463
		kW	0.60	1.16	1.90	2.52	3.07			
	P_{1TH}	hp	0.80	1.11	1.36	0.95	*			
		kW	0.60	0.83	1.02	0.71	*			
	T_{2ME}	lb-in	1,920	1,934	1,616	1,423	1,292			
		Nm	217	219	183	161	146			
T_{2ACC}	lb-in	1,923	1,938	1,947	1,760	1,616				
	Nm	217	219	220	199	183				
η	%	76	79	80	80	80				
30	P_{1ME}	hp	0.64	1.23	2.10	2.80	3.43	4000	3,798	429
		kW	0.48	0.92	1.57	2.09	2.56			
	P_{1TH}	hp	0.64	1.00	1.23	0.87	*			
		kW	0.48	0.75	0.92	0.65	*			
	T_{2ME}	lb-in	2,241	1,880	1,548	1,368	1,246			
		Nm	253	212	175	155	141			
T_{2ACC}	lb-in	1,771	1,784	1,791	1,682	1,548				
	Nm	200	202	202	190	175				
η	%	73	76	78	78	77				
40	P_{1ME}	hp	0.60	0.96	1.55	2.07	2.56	4000	4,680	529
		kW	0.45	0.71	1.16	1.55	1.91			
	P_{1TH}	hp	0.60	0.79	0.98	0.72	*			
		kW	0.45	0.59	0.73	0.53	*			
	T_{2ME}	lb-in	2,000	1,686	1,397	1,239	1,133			
		Nm	226	190	158	140	128			
T_{2ACC}	lb-in	2,340	2,000	1,686	1,514	1,397				
	Nm	264	226	190	171	158				
η	%	66	70	71	71	70				
50	P_{1ME}	hp	0.49	0.78	1.27	1.71	2.12	4000	4,414	499
		kW	0.37	0.58	0.95	1.27	1.58			
	P_{1TH}	hp	0.49	0.68	0.84	0.63	*			
		kW	0.37	0.50	0.62	0.47	*			
	T_{2ME}	lb-in	1,892	1,600	1,331	1,185	1,085			
		Nm	214	181	150	134	123			
T_{2ACC}	lb-in	2,207	1,892	1,600	1,440	1,331				
	Nm	249	214	181	163	150				
η	%	61	65	66	66	65				
60	P_{1ME}	hp	0.42	0.66	1.08	1.46	1.81	4000	4,139	468
		kW	0.31	0.50	0.81	1.09	1.35			
	P_{1TH}	hp	0.42	0.60	0.74	0.57	*			
		kW	0.31	0.45	0.55	0.43	*			
	T_{2ME}	lb-in	1,778	1,507	1,258	1,122	1,030			
		Nm	201	170	142	127	116			
T_{2ACC}	lb-in	2,069	1,778	1,507	1,359	1,258				
	Nm	234	201	170	154	142				
η	%	56	60	62	61	60				

Maximum input speed allowed for short acceleration cycles. See page 29 for rating definitions.

S09

i : 1	Ratings	Units	N_{1NOM} (rpm)				N_{1PK} rpm	T_{2MAX}		
			500	1,000	2,000	3,000		4,000	lb-in	Nm
5	P_{1ME}	hp	6.06	9.58	14.78	18.75	22.00	4000	8,201	927
		kW	4.52	7.14	11.02	13.98	16.40			
	P_{1TH}	hp	3.91	4.40	5.30	3.41	*			
		kW	2.92	3.28	3.95	2.54	*			
	T_{2ME}	lb-in	3,511	2,805	2,166	1,823	1,593			
		Nm	397	317	245	206	180			
T_{2ACC}	lb-in	4,173	3,511	2,805	2,423	2,166				
	Nm	472	397	317	274	245				
η	%	92	93	93	93	92				
7.5	P_{1ME}	hp	4.25	6.79	10.65	13.70	16.27	4000	8,771	991
		kW	3.17	5.06	7.94	10.21	12.13			
	P_{1TH}	hp	3.31	3.75	4.62	3.19	*			
		kW	2.47	2.79	3.45	2.38	*			
	T_{2ME}	lb-in	3,633	2,944	2,317	1,979	1,753			
		Nm	410	333	262	224	198			
T_{2ACC}	lb-in	4,385	3,633	2,944	2,569	2,317				
	Nm	495	410	333	290	262				
η	%	90	92	92	92	91				
10	P_{1ME}	hp	2.02	4.01	8.00	10.45	12.51	4000	4,452	503
		kW	1.50	2.99	5.96	7.79	9.33			
	P_{1TH}	hp	2.02	3.27	4.09	2.92	*			
		kW	1.50	2.44	3.05	2.18	*			
	T_{2ME}	lb-in	2,261	2,284	2,291	1,989	1,775			
		Nm	255	258	259	225	201			
T_{2ACC}	lb-in	2,266	2,293	2,306	2,308	2,306				
	Nm	256	259	261	261	261				
η	%	89	90	91	91	90				
15	P_{1ME}	hp	1.69	3.33	6.44	8.42	10.15	4000	5,381	608
		kW	1.26	2.48	4.80	6.28	7.57			
	P_{1TH}	hp	1.69	2.46	3.11	2.30	*			
		kW	1.26	1.84	2.32	1.71	*			
	T_{2ME}	lb-in	2,731	2,759	2,698	2,350	2,115			
		Nm	309	312	305	265	239			
T_{2ACC}	lb-in	2,736	2,767	2,784	2,788	2,698				
	Nm	309	313	315	315	305				
η	%	86	88	89	89	88				
20	P_{1ME}	hp	2.00	3.22	5.15	6.76	8.18	4000	9,735	1100
		kW	1.49	2.40	3.84	5.04	6.10			
	P_{1TH}	hp	1.70	1.91	2.42	1.82	*			
		kW	1.26	1.43	1.80	1.36	*			
	T_{2ME}	lb-in	4,114	3,418	2,782	2,437	2,204			
		Nm	465	386	314	275	249			
T_{2ACC}	lb-in	4,868	4,114	3,418	3,039	2,782				
	Nm	550	465	386	343	314				
η	%	82	84	86	86	85				

Maximum input speed allowed for short acceleration cycles. See page 29 for rating definitions.

S09

i : 1	Ratings	Units	N_{1NOM} (rpm)				N_{1PK} rpm	T_{2MAX}		
			500	1,000	2,000	3,000		4,000	lb-in	Nm
25	P_{1ME}	hp	1.63	2.61	4.19	5.51	6.69	4000	9,415	1064
		kW	1.21	1.95	3.12	4.11	4.99			
	P_{1TH}	hp	1.41	1.58	1.99	1.53	*			
		kW	1.05	1.18	1.49	1.14	*			
	T_{2ME}	lb-in	3,992	3,331	2,726	2,398	2,176			
		Nm	451	376	308	271	246			
T_{2ACC}	lb-in	4,707	3,992	3,331	2,970	2,726				
	Nm	532	451	376	336	308				
η	%	78	81	83	83	83				
30	P_{1ME}	hp	1.04	2.00	3.77	4.97	6.05	4000	6,401	723
		kW	0.78	1.49	2.81	3.71	4.52			
	P_{1TH}	hp	1.04	1.44	1.83	1.42	*			
		kW	0.78	1.07	1.36	1.06	*			
	T_{2ME}	lb-in	2,983	3,003	2,889	2,550	2,321			
		Nm	337	339	326	288	262			
T_{2ACC}	lb-in	2,986	3,007	3,020	3,023	2,889				
	Nm	337	340	341	342	326				
η	%	76	79	81	81	81				
40	P_{1ME}	hp	1.07	1.70	2.74	3.63	4.44	4000	8,770	991
		kW	0.80	1.27	2.04	2.71	3.31			
	P_{1TH}	hp	1.02	1.13	1.43	1.13	*			
		kW	0.76	0.84	1.07	0.85	*			
	T_{2ME}	lb-in	3,744	3,151	2,607	2,311	2,110			
		Nm	423	356	295	261	238			
T_{2ACC}	lb-in	4,385	3,744	3,151	2,827	2,607				
	Nm	495	423	356	319	295				
η	%	69	73	75	76	75				
50	P_{1ME}	hp	0.87	1.37	2.21	2.93	3.60	4000	8,191	926
		kW	0.65	1.02	1.65	2.19	2.68			
	P_{1TH}	hp	0.87	0.96	1.21	0.98	*			
		kW	0.65	0.72	0.91	0.73	*			
	T_{2ME}	lb-in	3,507	2,962	2,460	2,187	2,003			
		Nm	396	335	278	247	226			
T_{2ACC}	lb-in	4,096	3,507	2,962	2,663	2,460				
	Nm	463	396	335	301	278				
η	%	64	68	71	71	71				
60	P_{1ME}	hp	0.74	1.16	1.86	2.48	3.05	4000	7,726	873
		kW	0.55	0.87	1.39	1.85	2.28			
	P_{1TH}	hp	0.74	0.85	1.07	0.87	*			
		kW	0.55	0.63	0.80	0.65	*			
	T_{2ME}	lb-in	3,315	2,807	2,339	2,085	1,912			
		Nm	375	317	264	236	216			
T_{2ACC}	lb-in	3,863	3,315	2,807	2,529	2,339				
	Nm	436	375	317	286	264				
η	%	60	64	66	67	66				

Maximum input speed allowed for short acceleration cycles. See page 29 for rating definitions.

S11

i : 1	Ratings	Units	N_{1NOM} (rpm)				N_{1PK} rpm	T_{2MAX}		
			500	1,000	2,000	3,000		4,000	lb-in	Nm
5	P_{1ME}	hp	9.24	14.58	22.44	28.41	33.27	4000	13,147	1485
		kW	6.89	10.87	16.74	21.19	24.81			
	P_{1TH}	hp	4.88	5.49	6.48	4.33	*			
		kW	3.64	4.09	4.84	3.23	*			
	T_{2ME}	lb-in	5,384	4,297	3,314	2,786	2,434			
		Nm	608	485	374	315	275			
T_{2ACC}	lb-in	6,574	5,384	4,297	3,709	3,314				
	Nm	743	608	485	419	374				
η	%	92	94	94	93	93				
7.5	P_{1ME}	hp	6.42	10.26	16.05	20.60	24.42	4000	13,374	1511
		kW	4.79	7.65	11.97	15.36	18.21			
	P_{1TH}	hp	4.13	4.67	5.65	4.00	*			
		kW	3.08	3.49	4.21	2.98	*			
	T_{2ME}	lb-in	5,535	4,480	3,522	3,006	2,661			
		Nm	625	506	398	340	301			
T_{2ACC}	lb-in	6,687	5,535	4,480	3,908	3,522				
	Nm	756	625	506	442	398				
η	%	91	92	93	93	92				
10	P_{1ME}	hp	3.69	7.34	12.07	15.63	18.66	4000	8,229	930
		kW	2.75	5.47	9.00	11.65	13.92			
	P_{1TH}	hp	3.58	4.08	5.00	3.64	*			
		kW	2.67	3.04	3.73	2.72	*			
	T_{2ME}	lb-in	4,177	4,219	3,493	3,009	2,684			
		Nm	472	477	395	340	303			
T_{2ACC}	lb-in	4,185	4,232	4,257	3,855	3,493				
	Nm	473	478	481	436	395				
η	%	90	91	92	92	91				
15	P_{1ME}	hp	3.09	6.09	9.78	12.75	15.33	4000	9,965	1126
		kW	2.30	4.54	7.29	9.51	11.43			
	P_{1TH}	hp	2.70	3.07	3.79	2.85	*			
		kW	2.02	2.29	2.83	2.12	*			
	T_{2ME}	lb-in	5,056	5,106	4,148	3,610	3,248			
		Nm	571	577	469	408	367			
T_{2ACC}	lb-in	5,062	5,117	5,143	4,550	4,148				
	Nm	572	578	581	514	469				
η	%	87	89	90	90	90				
20	P_{1ME}	hp	3.04	4.90	7.83	10.25	12.38	4000	15,080	1704
		kW	2.27	3.65	5.84	7.65	9.23			
	P_{1TH}	hp	2.11	2.38	2.94	2.25	*			
		kW	1.57	1.77	2.19	1.67	*			
	T_{2ME}	lb-in	6,366	5,285	4,296	3,760	3,399			
		Nm	719	597	485	425	384			
T_{2ACC}	lb-in	7,540	6,366	5,285	4,695	4,296				
	Nm	852	719	597	530	485				
η	%	83	86	87	87	87				

Maximum input speed allowed for short acceleration cycles. See page 29 for rating definitions.

S11

i : 1	Ratings	Units	N_{1NOM} (rpm)					N_{1PK} rpm	T_{2MAX}	
			500	1,000	2,000	3,000	4,000		lb-in	Nm
25	P_{1ME}	hp	2.46	3.95	6.32	8.30	10.05	4000	14,534	1642
		kW	1.83	2.94	4.71	6.19	7.49			
	P_{1TH}	hp	1.74	1.96	2.42	1.87	*			
		kW	1.30	1.46	1.80	1.40	*			
	T_{2ME}	lb-in	6,157	5,133	4,196	3,687	3,345			
		Nm	696	580	474	417	378			
T_{2ACC}	lb-in	7,267	6,157	5,133	4,574	4,196				
	Nm	821	696	580	517	474				
η	%	79	83	84	85	85				
30	P_{1ME}	hp	1.89	3.56	5.70	7.50	9.10	4000	11,875	1342
		kW	1.41	2.65	4.25	5.59	6.79			
	P_{1TH}	hp	1.59	1.79	2.22	1.74	*			
		kW	1.19	1.33	1.65	1.29	*			
	T_{2ME}	lb-in	5,531	5,435	4,465	3,938	3,582			
		Nm	625	614	504	445	405			
T_{2ACC}	lb-in	5,535	5,573	5,435	4,857	4,465				
	Nm	625	630	614	549	504				
η	%	77	81	83	83	83				
40	P_{1ME}	hp	1.61	2.57	4.12	5.43	6.62	4000	13,589	1535
		kW	1.20	1.92	3.07	4.05	4.93			
	P_{1TH}	hp	1.25	1.39	1.73	1.38	*			
		kW	0.93	1.04	1.29	1.03	*			
	T_{2ME}	lb-in	5,796	4,874	4,027	3,567	3,256			
		Nm	655	551	455	403	368			
T_{2ACC}	lb-in	6,794	5,796	4,874	4,370	4,027				
	Nm	768	655	551	494	455				
η	%	71	75	78	78	78				
50	P_{1ME}	hp	1.29	2.05	3.28	4.33	5.29	4000	12,612	1425
		kW	0.96	1.53	2.44	3.23	3.95			
	P_{1TH}	hp	1.07	1.18	1.46	1.19	*			
		kW	0.80	0.88	1.09	0.89	*			
	T_{2ME}	lb-in	5,395	4,552	3,777	3,355	3,070			
		Nm	610	514	427	379	347			
T_{2ACC}	lb-in	6,306	5,395	4,552	4,090	3,777				
	Nm	712	610	514	462	427				
η	%	66	71	73	74	74				
60	P_{1ME}	hp	1.10	1.73	2.76	3.66	4.47	4000	11,938	1349
		kW	0.82	1.29	2.06	2.73	3.34			
	P_{1TH}	hp	0.94	1.03	1.28	1.05	*			
		kW	0.70	0.77	0.95	0.79	*			
	T_{2ME}	lb-in	5,117	4,329	3,604	3,209	2,942			
		Nm	578	489	407	363	332			
T_{2ACC}	lb-in	5,969	5,117	4,329	3,897	3,604				
	Nm	674	578	489	440	407				
η	%	62	66	69	70	70				

Maximum input speed allowed for short acceleration cycles. See page 29 for rating definitions.

APPLICATION TYPE

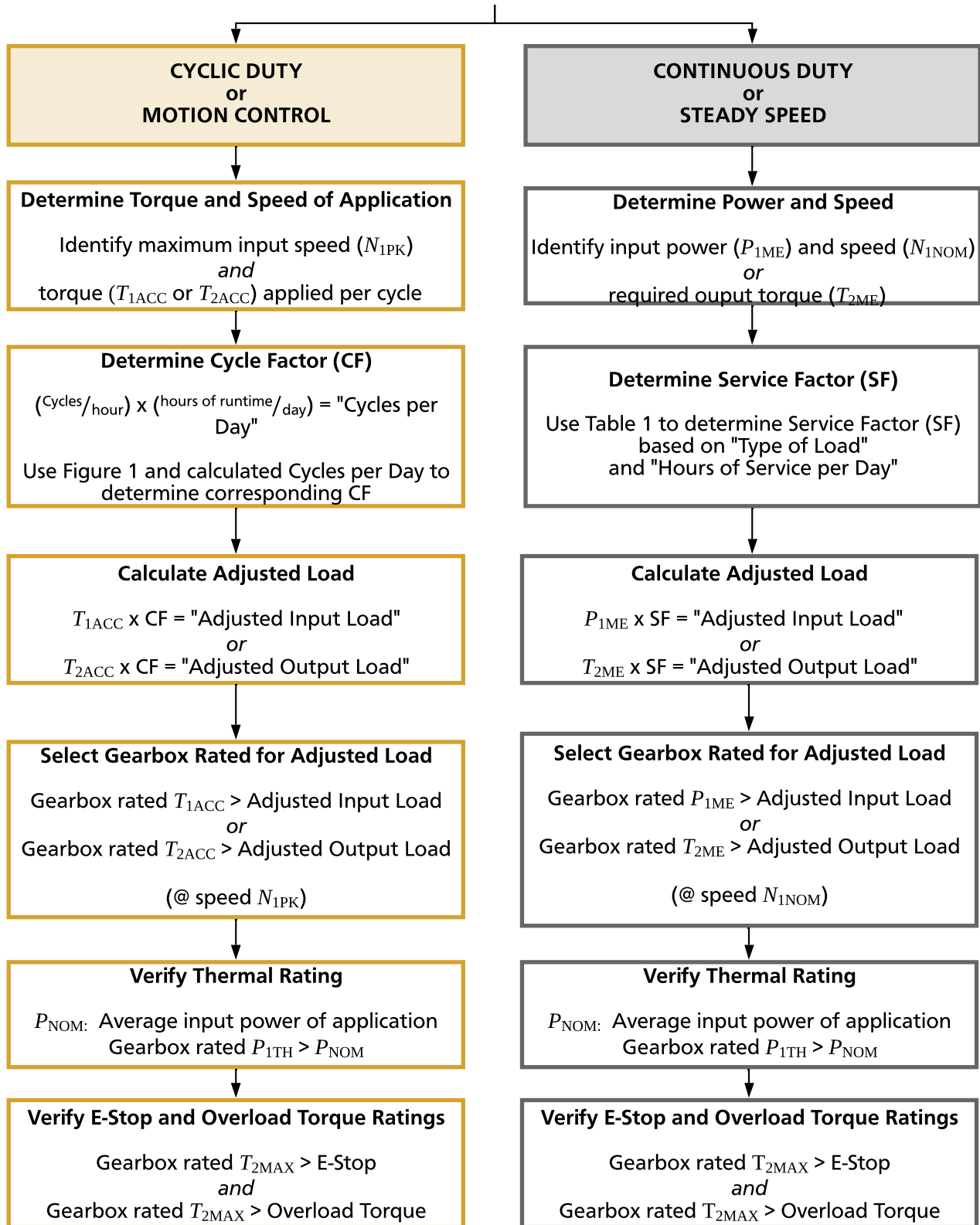

See appendix on next page for referenced nomenclature and conversions

CYCLE FACTOR

FOR CYCLIC DUTY OR MOTION CONTROL APPLICATIONS

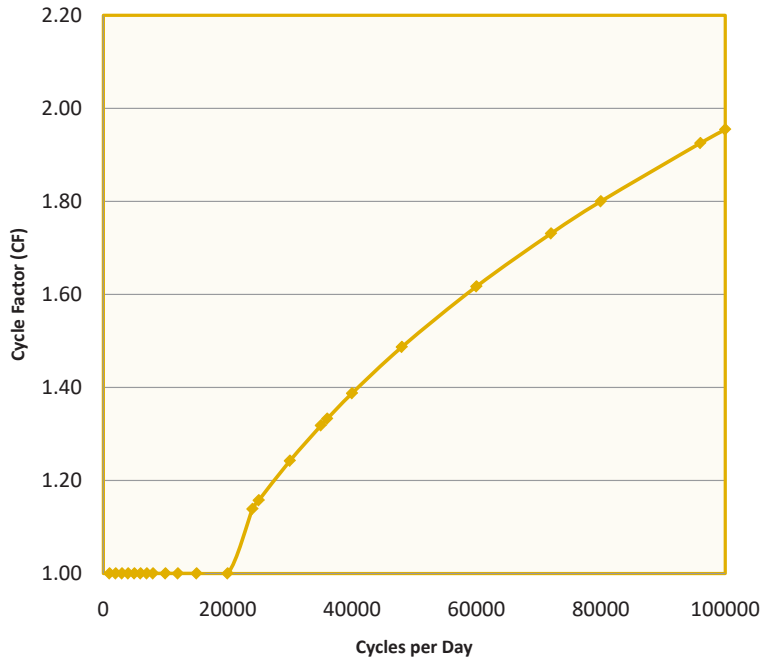

SERVICE FACTOR FOR CONTINUOUS DUTY OR STEADY SPEED APPLICATIONS

Hours of Service per Day	TYPE OF LOAD			
	Uniform	Moderate	Heavy	Extreme
0.5	0.8	0.9	1.0	1.2
2	0.9	1.0	1.2	1.3
10	1.0	1.3	1.5	1.7
24	1.3	1.5	1.7	2.0

Appendix

REFERENCED NOMENCLATURE

SYMBOL	UNITS	PRODUCT RATING DEFINITIONS
i	—	Ratio
$N_{1\text{NOM}}$	RPM	Nominal input speed
$N_{1\text{PK}}$	RPM	Maximum cyclic input speed permissible
$P_{1\text{ME}}$	HP	Mechanical input power rating (SF = 1.0)
$P_{1\text{TH}}$	HP	Continuous average thermal input power rating
$T_{1\text{ME}}$	lb-in	Mechanical input torque rating (SF = 1.0)
$T_{1\text{ACC}}$	lb-in	Cyclic operation input torque rating
$T_{2\text{ME}}$	lb-in	Mechanical output torque rating (SF = 1.0)
$T_{2\text{ACC}}$	lb-in	Cyclic operation output torque rating
$T_{2\text{MAX}}$	lb-in	Maximum E-stop output torque
η	%	Efficiency

CONVERSION EQUATIONS

$$1. \quad T_2 = T_1 \times i \times \eta$$

$$2. \quad P_1 = \frac{(T_2 \times N_1)}{(63,000 \times i \times \eta)}$$

LUBRICATION

Series S Servo Gearheads are factory filled with Mobil SHC634 synthetic lubricant. They are sealed and require no lubrication service throughout the life of the unit. Series S Servo gearheads are built for universal mounting, ready to mount in any position.

MOUNTING SERVO MOTOR ON GEARHEAD

1. Clean motor shaft and mating surfaces of the motor and gearhead to ensure they are dust-free.
2. Mount the coupling halves on gearhead shaft and servo motor half following the process described on next page.
3. The tightening torque for the coupling clamping screws is as follows:
 - a. S02 thru S09: 90 lb.in. (10 Nm)
 - b. S11: 220 lb.in. (25 Nm)

SECURING REDUCER TO MACHINE BASE

1. The machine base must be flat within .002" (0.05 mm) over the entire area in contact with the reducer.
2. When bolting the reducer to machine base, tighten foundation bolts to housing observing these torque values:

Reducer Size	Bolt Size	Torque ft-lb	Torque Nm
S02 (34 mm)	M8	18 - 22	24 - 30
S03 (39 mm)	M8	18 - 22	24 - 30
S05 (50 mm)	M10	37 - 44	50 - 60
S06 (60 mm)	M10	37 - 44	50 - 60
S09 (76 mm)	M12	65 - 77	88 - 105
S11 (90 mm)	M16	161 - 192	218 - 261

3. If a solid output is used, the output shaft of the gearhead should be coupled to the driven shaft with a flexible coupling and the gearhead aligned with the shaft within +/- .001." Solid or rigid couplings should be avoided. Failure to properly align shafts and the use of solid couplings can result in excessive coupling and bearing wear, shaft deflection and eventual failure of one or more of the components.

ANCILLARY COMPONENTS

1. When mounting couplings, pulleys or gears directly to the gearhead, refrain from hammering the component onto the shaft. If pressing the component onto the shaft, adequately support the gearhead's shaft in such a manner that prevents the gearhead bearings from supporting the press force, as the force to press on components may fail the bearings or individual components.
2. Sprockets, gears and sheaves should be mounted as close to the gearhead as possible. Belts and chains must be adjusted to the proper tension to keep bearing loading and shaft deflection to a minimum. Too much tension and improper location will lead to excessive overhung load, bearing wear and shaft deflection. For specific information on overhung load capacity, shaft stress and bearing life, please contact Cone Drive.

START-UP

1. All gearheads require a "run-in" period under load to achieve optimum efficiency. During this initial run-in the gearhead will probably run warmer than normal and draw more current than after the run-in period. Gearheads operating at a very low load or speed will take much longer to run-in.
2. **IMPORTANT:** Normal gearhead operating temperature measured at the oil sump area of the housing should not exceed 200° F (93° C) maximum. If the gearhead operating temperature exceeds these limits, shut down the unit and contact Cone Drive. Excessive oil sump temperature may be indicative of overloading, misalignment, or improper lubrication. Continuous operation of the gearhead with the oil sump temperature above 250° F (120° C) for the synthetic lubricant, will result in failure of the gearhead.

MAINTENANCE

1. Series S gearheads require no periodic maintenance. They are not user-serviceable or repairable.
2. If a gearhead is to be returned, contact Cone Drive for instructions and a Return Material Authorization (RMA) number.
3. Please have model number information from the unit nameplate recorded.

The coupling's three piece design allows the hubs to be installed on each individual shaft and then joined axially.

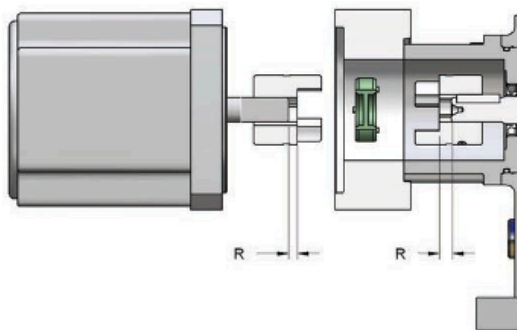
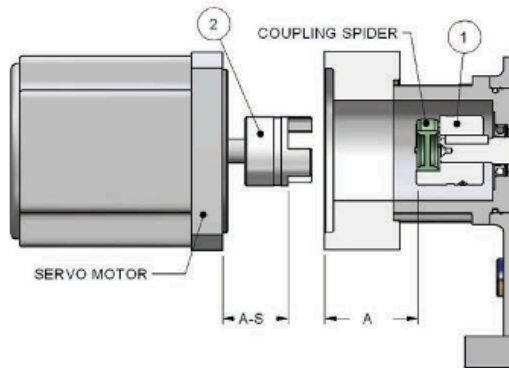

PROCEDURE

1. The coupling hub #1 will be installed on the gearhead from the factory.
2. Measure "A" dimension from end of coupling to mating face of flange.
3. Subtract "S" (see table below) from "A".
4. Locate coupling hub #2 on motor shaft so that the inside face of the coupling is located "A-S" from the mating motor face, as shown.
5. Tighten the clamp screw to the torque specified below.
6. Measure dimension "R" on the motor shaft. This is the distance that the shaft does not extend through the full-length of the coupling bore. If R is greater than the value shown in table below, reposition the coupling hub #1 on the gearhead outward about half the measured distance. Be sure to tighten the coupling clamp screw to the proper torque.
7. Repeat steps 2 through 5.
8. After positioning, dimension "R" shouldn't exceed the value in the table for either coupling half.
9. Lightly oil the coupling spider and position it on coupling hub #1.
10. Assemble the motor to the gearhead. If required, rotate the shafts

Unit Size	Dimension "S"	Dimension "R"	Coupling Clamp Screw Torque
S02, S03, S05	0.08" (2 mm)	0.31" (8 mm)	93 in lb (10 Nm)
S06, S09	0.08" (2 mm)	0.57" (14.5 mm)	93 in lb (10 Nm)
S11	0.10" (2.5 mm)	0.73" (18.5 mm)	220 in lb (25 Nm)

SAFETY PRECAUTIONS

IMPORTANT: In any applications of Cone Drive Products where breakage, damage, disconnection, any other malfunction of any drive train component, or excessive wear could result in personal injury or property damage, a fail-safe device capable of stopping and holding the load in the event of such an occurrence must be incorporated after the drive train.

THE FOLLOWING INFORMATION IS FOR YOUR PROTECTION. DO NOT ATTEMPT TO INSTALL OR OPERATE THIS GEARBOX UNTIL ALL OF THESE INSTRUCTIONS ARE READ AND THOROUGHLY UNDERSTOOD.

SELF-LOCKING

It is a common misconception that all worm gears are self-locking or non-overhauling. Actually, worm gear ratios up to 15:1 will overhaul quite freely. Ratios from 20:1 to 40:1 can generally be considered as overhauling with difficulty (particularly from rest). Ratios above 40:1 may or may not overhaul depending on loading, lubrication, and the amount of vibration present. Cone Drive cannot guarantee any worm gear ratio to be self-locking. There have been instances where single reduction ratios as high as 100:1 have overhauled. Therefore, it is not acceptable to rely on a worm gear to prevent movement in a system. Whenever a load must be stopped or held in place, a positive mechanical device must be incorporated into the system to prevent rotation of the gear set.

BACKDRIVING OR OVERHAULING

Applications such as wheel drives that require a brake on the motor or input shaft to decelerate a high inertial load require special attention to brake selection. Whenever possible, these applications should utilize freely overhauling ratios (15:1 or less). If self-locking ratios are used with a brake, the gear set can, under certain conditions, lock-up during decelerations and impose severe shock loading on the gearbox and driven equipment. Each reduction should be limited to 15:1 or less to allow the gearbox to overhaul. Contact Cone Drive for specific information on backdriving efficiency and brake selection.

RATINGS & SERVICE FACTORS

The horsepower or output torque capacity of this gearbox and the service factor (maximum allowable operating cycle) are documented in the product catalog. These values are not to be exceeded as overloading can result in gearbox failure. Exceeding the rating and duty cycle will void the warranty. Please contact Cone Drive with any questions regarding rating and service factors.

ALTERATION

Do not alter the gearbox without approval from Cone Drive.

OPERATION & REPAIR

This gearbox has moving mechanical components and may have connected electrical devices operating under high voltage. Operation and repair should only be done by qualified personnel.

PROTECTIVE GUARDING

Cone Drive products are furnished without guard covers. It is the responsibility of the purchase or user to provide guards for all exposed shafting, couplings, sprockets, sheaves, belts, chains, clutches, and any other moving parts in accordance with current local, state, and federal requirements.

LOCK-OUT/TAG-OUT

Before servicing a gearbox, the main electrical disconnect or other input power sources must be moved to and locked in the off-position. The person performing the work should post on that disconnect a warning to others not to turn on the power. Loads on the input and output shafts should be disconnected prior to working on the gearbox.

GEARBOX SURFACE IS HOT

It is normal for the gearbox to operate at temperatures up to and exceeding 200°F. To prevent burns, proper personal protective equipment, guards, or shields should be provided by the purchaser or user to prevent personnel from touching the gearbox.



GLOBAL LOCATIONS

NORTH AMERICA | EUROPE | ASIA



+1 888 994 2663 | orders@conedrive.com | conedrive.com | conetools.com

12082020

Courtesy of Steven Engineering, Inc - (800) 258-9200 - sales@steveneng.com - www.stevenengineering.com