

EWELLIX

A Schaeffler Company

Miniature profile rail guides – LLS catalogue



Contents

1. Introduction	4	4. Mounting and maintenance	49
1.1 Product description.....	5	4.1 Design rules	50
1.2 Function and basic design	6	4.1.1 Use of profile rails.....	50
1.3 Components and materials.....	7	4.1.2 Typical mounting	50
1.4 Features and benefits.....	8	4.1.3 Interface design and bolt torque	51
1.5 Product range.....	10	4.1.4 Maximum height deviation.....	52
1.5.1 Standard carriages and rails.....	10	4.1.5 Parallelism of guide systems	53
1.5.2 Wide carriages and rails	11	4.1.6 Tolerance of rail mounting holes	54
1.5.3 Product size options	12	4.2 Mounting profile rail guides	55
1.5.4 Customized options.....	13	4.2.1 Packaging (Shipment)	55
1.5.5 Zero Rail Concept (ZRC) range	14	4.2.2 Mounting the ZRC carriages	55
1.5.6 System range	15	4.2.3 Preparation	55
1.6 Miniature guide applications	16	4.2.4 Mounting the rail	56
2. Selection guide	18	4.2.5 Parallel alignment of rail	56
2.1 Technical data	19	4.3 Maintenance and repairs	59
2.1.1 Load ratings.....	19	4.3.1 Lubrication and maintenance	59
2.1.2 Preload classes.....	20	4.3.2 Factory pre lubrication	59
2.1.3 Precision classes	20	4.3.3 Correct relubrication.....	59
2.1.4 Rigidity.....	22	4.3.4 Relubrication interval.....	59
2.1.5 Performance data	24	4.4 Storage environment recommendations	60
2.1.6 Friction.....	25	5. Ordering key	62
2.2 Selection of profile rail guides	26	Ordering key systems.....	63
2.2.1 Rating life	26	Ordering key ZRC carriages.....	64
2.2.2 Influence factors	27	Ordering key ZRC rails	65
2.2.3 Dynamic bearing loads.....	28	6. Customer specification sheet	66
2.2.4 External force calculation	30		
2.2.5 Static bearing load	32		
2.2.6 Linear guide calculator	33		
3. Product range	34		
3.1 Carriage data	35		
3.1.1 Standard carriage.....	36		
3.1.2 Standard carriage extended length	38		
3.1.3 Wide carriage	40		
3.1.4 Wide carriage extended length	42		
3.2 Rail data	44		
3.2.1 Standard rails	44		
3.2.2 Wide rails	46		
3.2.3 Number of holes and E-dimension	48		

The heritage of innovation

Ewellix is a global innovator and manufacturer of linear motion and actuation solutions. Our state-of-the-art linear solutions are designed to increase machine performance, maximise uptime, reduce maintenance, improve safety and save energy. We engineer solutions for assembly automation, medical equipment, mobile machinery, distribution and a wide range of other industrial applications.

Technology leadership

We earned our reputation through decades of engineering excellence. Our journey began over 50 years ago as part of the SKF Group, a leading global technology provider. Our history provided us with the expertise to continuously develop new technologies and use them to create cutting edge products that offer our customers a competitive advantage.

In 2019, we became independent and changed our name to Ewellix. We are proud of our heritage. This gives us a unique foundation on which to build an agile business with engineering excellence and innovation as our core strengths.

Global presence and local support

With our global presence, we are uniquely positioned to deliver standard components and custom-engineered solutions, with full technical and applications support around the world. Our skilled engineers provide total life-cycle support, helping to optimise the design, operation and maintenance of equipment thus improving productivity and reliability while reducing costs. At Ewellix, we don't just provide products; we engineer integrated solutions that help customers realise their ambitions.



Schaeffler Group – We pioneer motion

Ewellix is since 2023 owned by the Schaeffler Group.

As a leading global supplier to the automotive and industrial sectors, the Schaeffler Group has been driving forward groundbreaking inventions and developments in the fields of motion and mobility for over 75 years.

With innovative technologies, products, and services for electric mobility, CO₂-efficient drives, Industry 4.0, digitalization, and renewable energies, the company is a reliable partner for making motion and mobility more efficient, intelligent, and sustainable.

Schaeffler manufactures high-precision components and systems for powertrain and chassis applications as well as rolling and plain bearing solutions for a large number of industrial applications.



Trusted engineering expertise

Our industry is in motion; pushing towards solutions that reduce environmental impact and leverage new technology. We provide technical and manufacturing expertise to overcome our customers' challenges.

Engineering for the future

We work in a **wide range of industries**, where our solutions provide key functionality for business critical applications.

For the **medical industry**, we provide precision components for use in core medical equipment.

Our unparalleled understanding of **assembly automation** systems is based on decades of research into advanced automation components and techniques.

Our deep knowledge of **mobile machinery** provides powerful and reliable electromechanical solutions for the harshest conditions. In an **industrial distribution** setting, we supply linear expertise to our partners, empowering them to serve customers with greater efficiency.

We offer excellence

We have a **unique understanding of linear equipment** and how it's integrated in customers' applications to provide the best performance and machine efficiency.

We assist our customers by creating equipment that runs faster, longer and that is safe and sustainable.

We provide a wide variety of **linear motion components** and **electromechanical actuators** for equipping any automation application, thus helping our customers **increase productivity, reduce their footprint, energy use and maintenance.**

Actuation systems



Ball and roller screws



Linear guides and systems



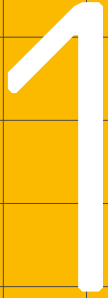

1

Introduction

1.1 Product description

The demands placed on modern linear guidance technology have risen significantly in recent years - especially in terms of service life, and precise motion combined with high robustness of the product. At the same time, users expect installation and maintenance outlay to be as low as possible.

With the new miniature profile rail guide series LLS, Ewellix is exactly targeting the newest industry trends and fulfilling their demands. Their new innovative design couples practical experience gained in several industries with the latest findings from our own research and development.

The new range of miniature profile rail guides are the ideal solution for applications requiring compact dimensions, high running accuracy, long service life and low noise as, for example, in laboratory automation equipment, industrial automation and a lot of other industries.

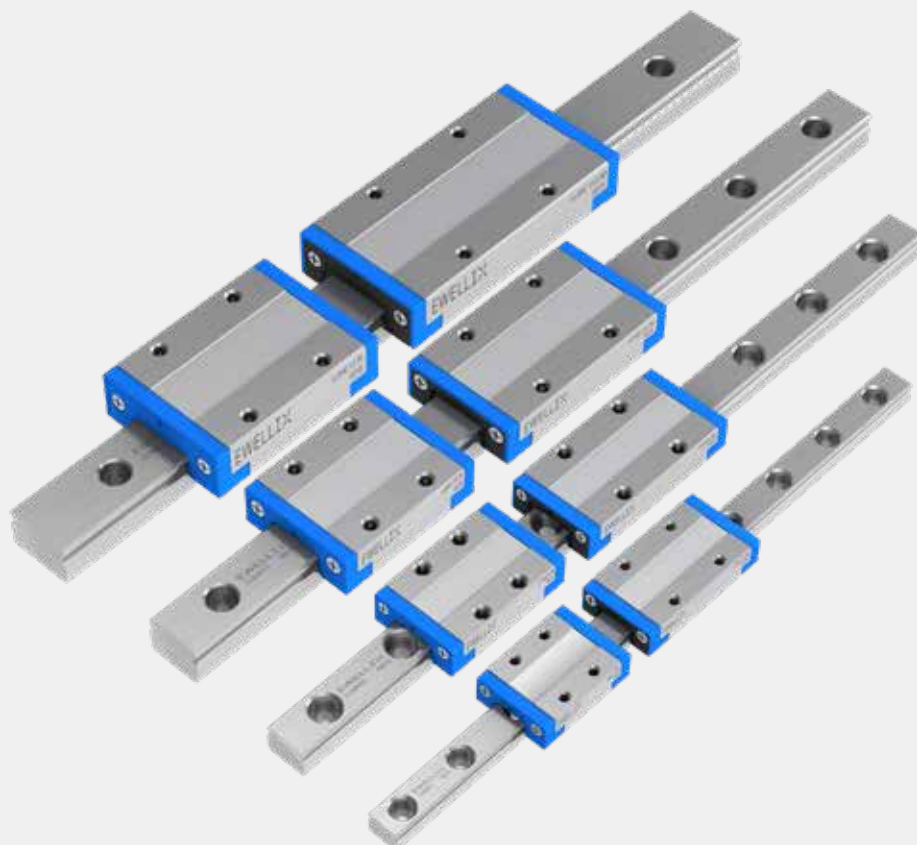

1.2 Function and basic design

Miniature profile rail guides are translating rolling motion into linear motion. Like a ball bearing, the rolling elements are allowing nearly frictionless linear movements even under load. For that function a profile rail system consists of two elements; a carriage and a rail. In most applications, the rail is

fixed to a ground and the carriage is moving. The carriage contains the rolling elements and a ball recirculation system. The ball recirculation system allows in principal unlimited stroke of the carriage along the rail.

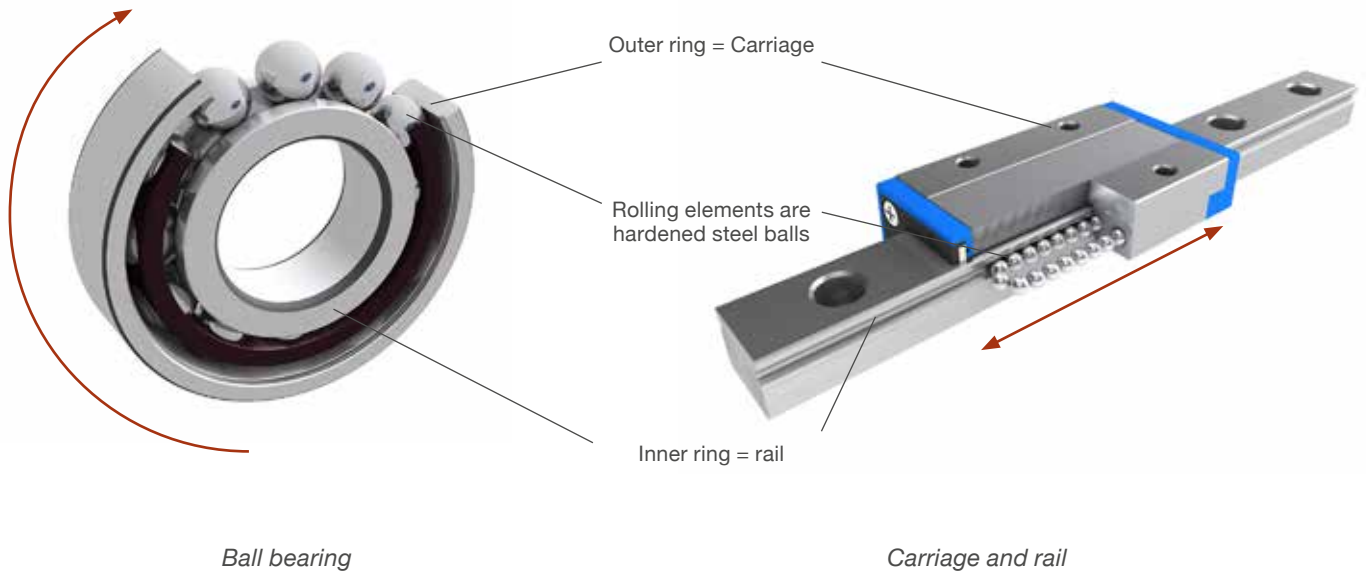

Fig. 1

The miniature profile rail is made with a two-row ball recirculation. To guarantee precise motion within a two-ball row design, Ewellix is using a gothic arch shape in the ball contact zone at carriages and rails. This four-point ball contact design ensures a compact design that delivers high performance (↳ fig. 1).

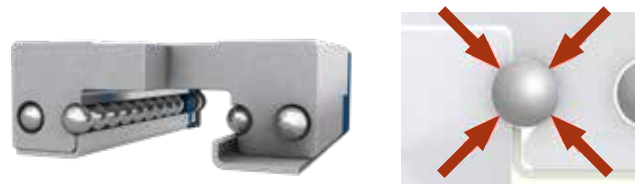
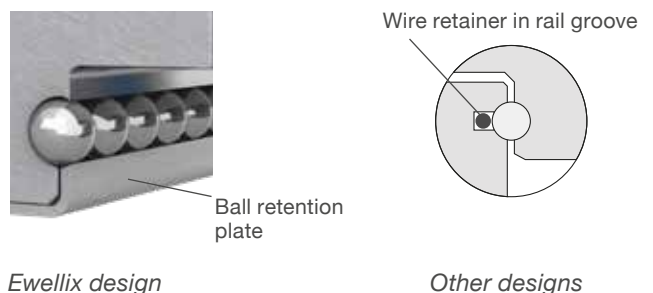
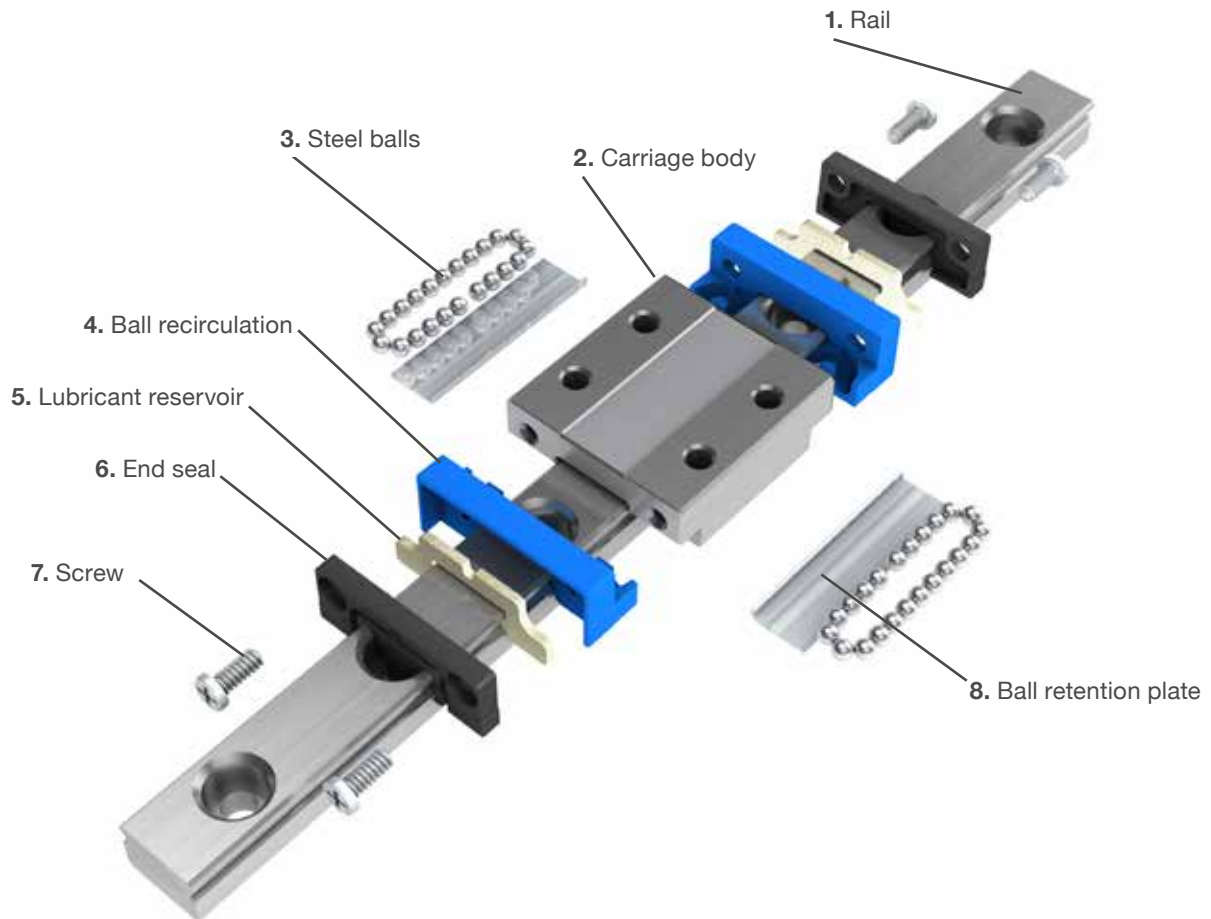

Fig. 2

The innovative new ball retention system obtains the highest sealing performance, the utmost safe mounting process and the highest quality ball retention system (↳ fig. 2).



1.3 Components and materials



Material specifications

1. Profile rail, stainless steel (hardened)
2. Carriage body, stainless steel (hardened)
3. Steel balls, stainless steel (hardened)
4. Ball recirculation, plastic (POM)
5. Lubricant reservoirs, foam
6. End seals or shields, elastomer and plastic
7. Mounting screws, stainless steel
8. Ball retention plates, stainless steel

1.4 Features and benefits



Ball retention plate

Ewellix design

Wire retainer in rail groove

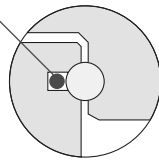

Other designs

Safe and robust innovative ball retention

The invention of the new ball retention system is setting milestones in terms of the highest safety during the mounting procedure.

The ball retention plate is attached to the carriage and is keeping the balls safely in position.

In comparison to other designs like the wire retention, it does not need an additional groove in the raceways of the rail, which is an entry point for contamination.

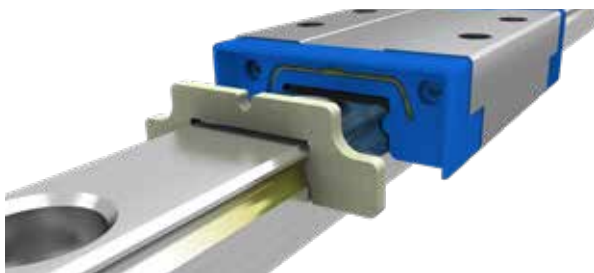

Up to 20 000 km of service life

Carriages and systems of the LLS miniature profile rail guide series are ready to use, while factory pre-lubricated with FDA level oil.

Even better, with the two integrated lubricant reservoirs on either carriage sides, the carriage can be maintenance-free for up to 20 000 km in service life.

The reservoir is in contact with the raceways of the rails and during motion is constantly oiling the ball contact point.

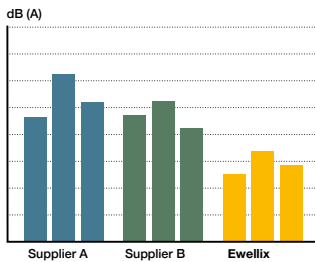

Silent and smooth precise motion

The optimized design has up to 50 % less noise emission when compared to other miniature profile rail products. That includes very smooth carriage running behaviour realized by the new optimized ball recirculation and retention.

Specific in medical and office environment applications, you will directly hear and feel the difference when compared to other miniature profile rails.



Stainless steel material

The LLS series is made for applications requesting clean environment and corrosion protection such as medical laboratory or office environment as well as automation and electronic industry production.

To protect carriage, rail and rolling elements from immediate initial rust, they are made from high alloy stainless steel material.

Low friction long life seal design

With seals made from highly abrasion resistant material, the miniature profile rail is perfectly protected from outside contamination. The seals are designed for the longest life and lowest possible friction force.

Even contamination from the carriage bottom side is restricted by the minimal gap seal between the rail and ball retention plate. All in all, it provides safe and long life protection.

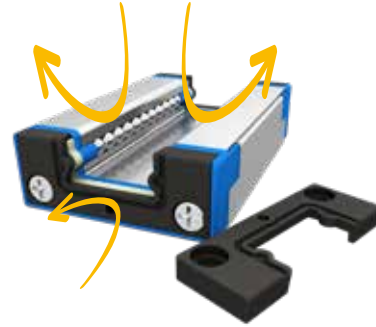

Secure, safe and quick mounting

Do you want to boost your mounting productivity? Then the LLS series is the right choice.

Due to the innovative ball retention, no mounting sleeves must be used and there is no risk of losing balls during mounting as with other solutions.

With each 2-mounting reference sides on carriage and rail, the mounting of such a linear guide system is fail safe proof that, as during mounting, no wrong side can be chosen.

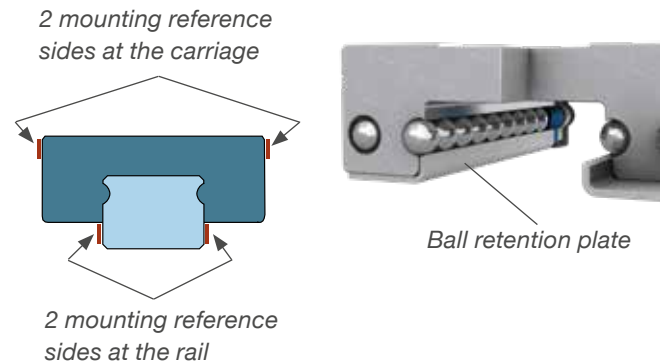

Interchangeable carriages and rails

With the new Zero Rail Concept (ZRC), Ewellix is increasing the flexibility in availability, stocking and repair because of interchangeable carriages on rails.

Within the Zero Rail Concept, any carriage can be mounted together with the rail of the same size. The realisation of a needed system is getting easier and delivery times are shorter, as Zero Rail Concept carriages and rails are stored and delivered separately.



Higher performance for more productivity

The new design with optimized ball contact point geometry and a ball recirculation system is adding much more performance to the guide system's ability.

The miniature profile rail series LLS is supporting speeds up to 5 m/s and accelerations up to 140 m/s². These performance parameters paired with the right drive system can accelerate your machine performance towards more productivity.



Speed up to 5 m/s

Acceleration up to 140 m/s²

1.5 Product range

1.5.1 Standard carriages and rails

Range with standard rail width for most compact applications, type LLSH, contains two variants of carriage length each in a shielded version with only rolling friction and a sealed version with very low friction. For more technical dimensions and details, please have a look at **chapter 3**.

Carriage LLSHC ... TA

Standard length - TA
Shielded with only rolling friction (no code)

Carriage LLSHC ... TA R

Standard length - TA
Sealed with very low friction - R



Detailed view at shielded carriage

Detailed view at sealed carriage

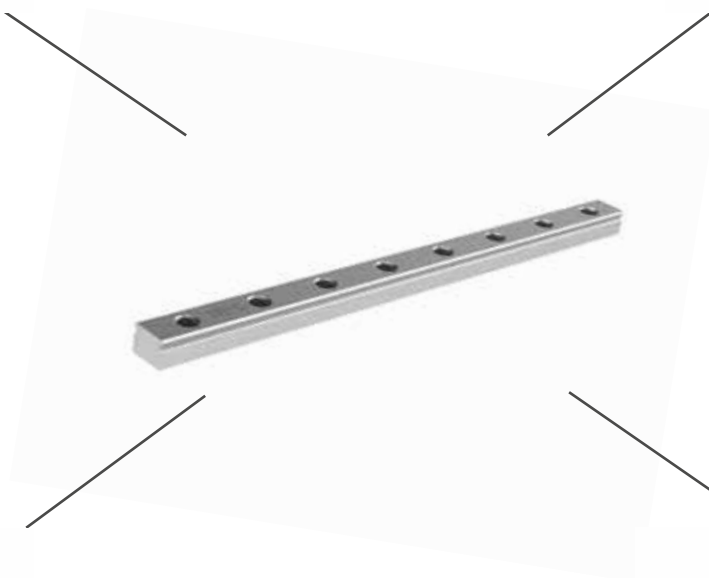

Carriage LLSHC ... LA

Extended length - LA
Shielded with only rolling friction (no code)

Carriage LLSHC ... LA R

Extended length - LA
Sealed with very low friction - R

1.5.2 Wide carriages and rails

Range with wide rail width for highest performance on one rail solutions, type LLSW, contains two variants of carriage length each in a shielded version with only rolling friction and a sealed version with very low friction. For more technical dimensions and details, please have a look at **chapter 3**.

Carriage LLSWC ... TA

Standard length - TA
Shielded with only rolling friction (no code)

Carriage LLSWC ... TA R

Standard length - TA
Sealed with very low friction - R



Detailed view at shielded carriage

Detailed view at sealed carriage

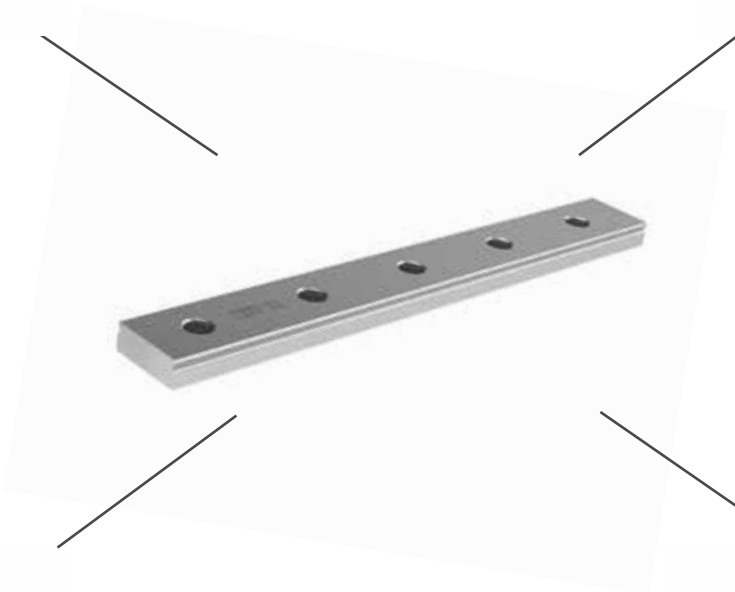

Carriage LLSWC ... LA

Extended length - LA
Shielded with only rolling friction (no code)

Carriage LLSWC ... LA R

Extended length - LA
Sealed with very low friction - R

1.5.3 Product size options

Standard sizes

On the standard range, type LLSH, the size of the rails is defining the size of the miniature profile rails system. Today, the range is available from 7 to 15 mm rail width.

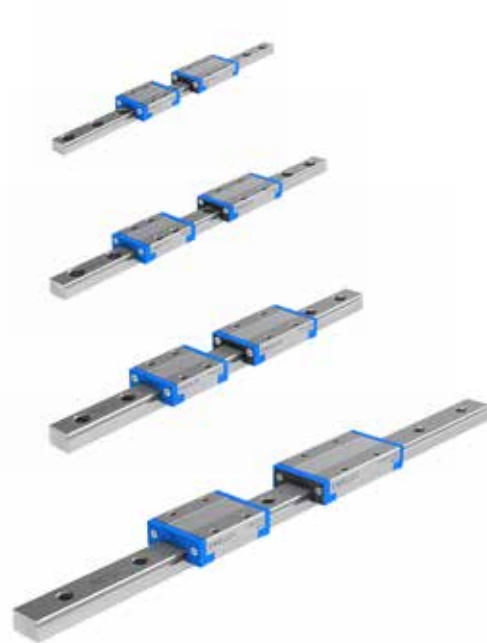
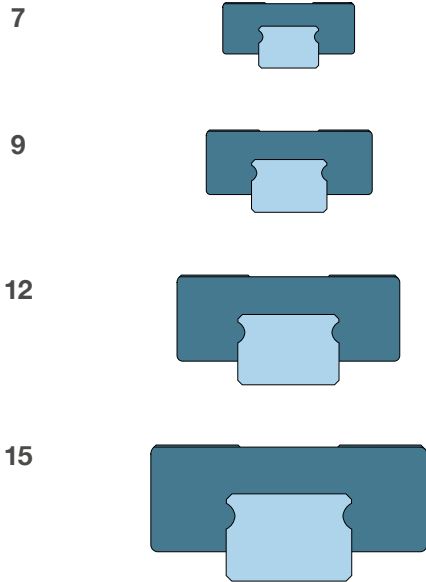

Wide sizes

The wide range, type LLSW, is defined as the double width of the standard rail with the exception of size 15, which is 42 mm wide.

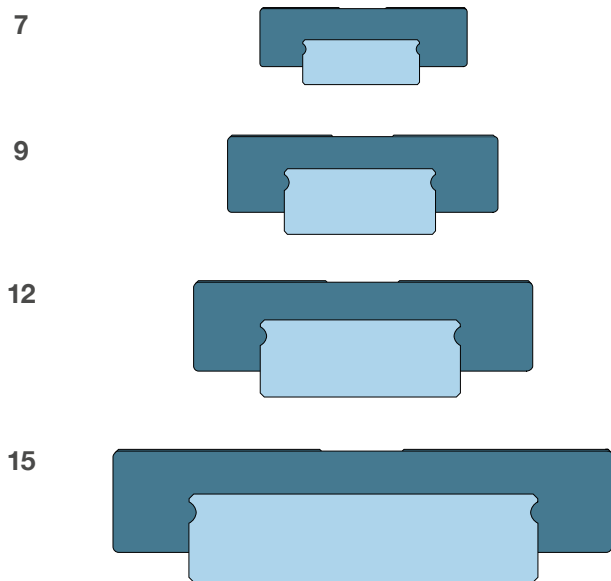

1.5.4 Customized options

On request, Ewellix can offer the following customized solutions to make the linear guide fit to the application.

Carriage examples

- Carriages without standard oil lubrication or carriages with customized lubricant according to specific application needs or specific lubrication holes for central lube systems.
- Carriages with hole patterns in the middle section used for rail or other mounting procedures when stroke is extremely short.
- Carriages with customized mounting threads to adapt to the design needs of a specific machine. The threads must fit a possible of general design.

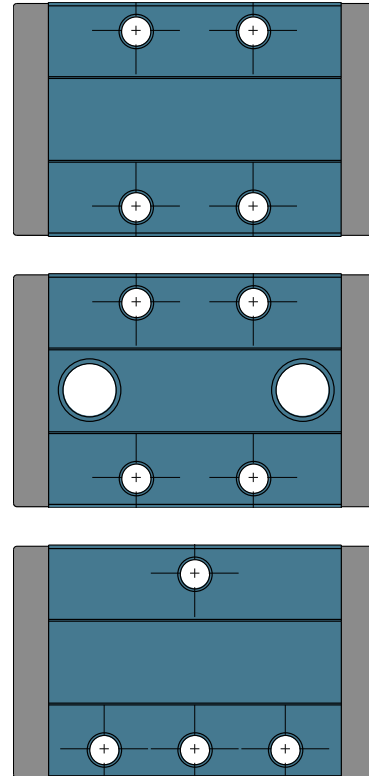

Rail examples

- Variable mounting hole distances according to drawings to adapt to specific needs or only mounting holes at the end of the rail for easy mounting.
- Blind threads for bottom mounting for clean upside rail surfaces. Or blind holes or through holes for exact position of the rail at a certain position to maintain tolerances.
- Rails without any fixation holes being used for alternative fixation methods like glueing or other fixation alternatives.

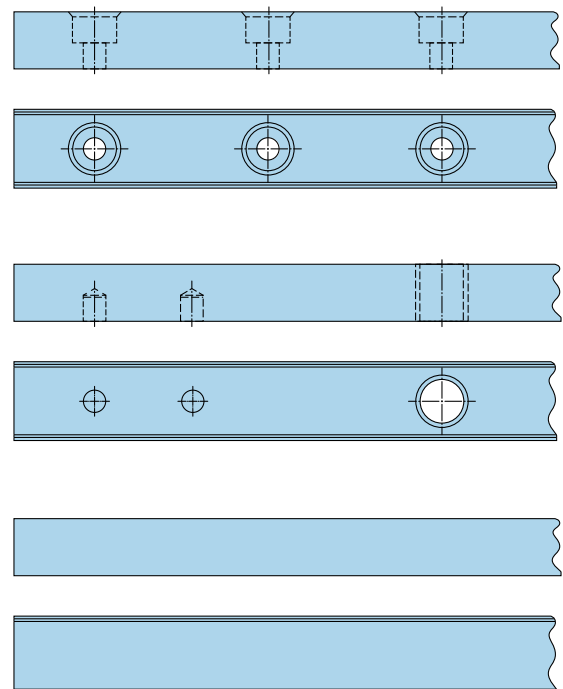

1.5.5 Zero Rail Concept (ZRC) range

The newly developed Ewellix Zero Rail Concept (ZRC) offers flexibility and availability. Within the Zero Rail Concept, any carriage can be mounted together with the rail of the same size. Spare parts can be handled much quicker and due to standardization, delivery times are shorter in comparison to system configurations.

Zero Rail Concept carriages and rails are delivered separately. The ZRC offer is standardized for precision class P5 (Standard precision) together with preload class T0 (Light clearance) and T1 (Light preload). Any carriage or rail from this range must be ordered with the suffix ZRC in the ordering key. For detail technical dimensions, please have look at **chapter 3**. For technical documentation like preload classes, please see **chapter 2**.



LLS range overview - ZRC ¹⁾

Series	Range	Type	Size	Length ²⁾	Shielded or sealed	Preload class	Precision class	Zero Rail Concept	
	H	C, R	7, 9, 12, 15	TA, LA	No code, R	T0, T1	P5	ZRC	
LLS	Standard rail width	Carriage	7	Standard	No code, R	T0, T1	P5	ZRC	
				Extended	No code, R	T0, T1	P5	ZRC	
			9	Standard	No code, R	T0, T1	P5	ZRC	
				Extended	No code, R	T0, T1	P5	ZRC	
			12	Standard	No code, R	T0, T1	P5	ZRC	
				Extended	No code, R	T0, T1	P5	ZRC	
			15	Standard	No code, R	T0, T1	P5	ZRC	
				Extended	No code, R	T0, T1	P5	ZRC	
			Rail	7	max. 1000 mm	---	---	P5	ZRC
				9	max. 2000 mm	---	---	P5	ZRC
	12	max. 2000 mm		---	---	P5	ZRC		
	15	max. 2000 mm		---	---	P5	ZRC		
		W	C, R	7, 9, 12, 15	TA, LA	No code, R	T0, T1	P5	ZRC
	LLS	Wide rail width	Carriage	7	Standard	No code, R	T0, T1	P5	ZRC
Extended					No code, R	T0, T1	P5	ZRC	
9				Standard	No code, R	T0, T1	P5	ZRC	
				Extended	No code, R	T0, T1	P5	ZRC	
12				Standard	No code, R	T0, T1	P5	ZRC	
				Extended	No code, R	T0, T1	P5	ZRC	
15				Standard	No code, R	T0, T1	P5	ZRC	
				Extended	No code, R	T0, T1	P5	ZRC	
Rail				7	max. 2000 mm	---	---	P5	ZRC
				9	max. 2000 mm	---	---	P5	ZRC
		12	max. 2000 mm	---	---	P5	ZRC		
		15	max. 2000 mm	---	---	P5	ZRC		

¹⁾ For detail information about the complete ordering key, please have a look at **chapter 5**.

²⁾ Rails manufactured as cut to length items might not be able to be delivered with the max. length due to the E dimension.

Ordering and designation example:

Carriage: LLSHC 12 TAR T0 P5 ZRC

Rail: LLSHR 12-550 P5 E0 ZRC

1.5.6 System range

While the ZRC rails and carriages are delivered separately, the system range offers you complete mounted guide systems of carriages and rails. Beside the readiness of the systems, more variations of preload and precision classes as well as optimized parallel running systems can be selected from the standard.

For detail technical dimension, please have look at **chapter 3**. For technical documentation like preload classes, please see **chapter 2**.



LLS range overview - SYSTEM ¹⁾

Series	Range	Type	Size	Carriage length	Shielded or sealed	Preload class	Rail length ²⁾	Precision class	Parallel mounted rails
	H	S	7, 9, 12, 15	TA, LA	No code, R	T0, T1, T2	[mm]	P5, P1	No code, W2, Wx
LLS	Standard rail width	System of carriage and rail ready mounted	7	Standard	No code, R	T0, T1, T2	max. 1000	P5, P1	No code, W2, Wx
				Extended	No code, R	T0, T1, T2	max. 1000	P5, P1	No code, W2, Wx
			9	Standard	No code, R	T0, T1, T2	max. 2000	P5, P1	No code, W2, Wx
				Extended	No code, R	T0, T1, T2	max. 2000	P5, P1	No code, W2, Wx
			12	Standard	No code, R	T0, T1, T2	max. 2000	P5, P1	No code, W2, Wx
				Extended	No code, R	T0, T1, T2	max. 2000	P5, P1	No code, W2, Wx
			15	Standard	No code, R	T0, T1, T2	max. 2000	P5, P1	No code, W2, Wx
				Extended	No code, R	T0, T1, T2	max. 2000	P5, P1	No code, W2, Wx

	W	S	7, 9, 12, 15	TA, LA	No code, R	T0, T1	[mm]	P5, P1	No code, W2, Wx
LLS	Wide rail width	System of carriage and rail ready mounted	7	Standard	No code, R	T0, T1, T2	max. 2000	P5, P1	No code, W2, Wx
				Extended	No code, R	T0, T1, T2	max. 2000	P5, P1	No code, W2, Wx
			9	Standard	No code, R	T0, T1, T2	max. 2000	P5, P1	No code, W2, Wx
				Extended	No code, R	T0, T1, T2	max. 2000	P5, P1	No code, W2, Wx
			12	Standard	No code, R	T0, T1, T2	max. 2000	P5, P1	No code, W2, Wx
				Extended	No code, R	T0, T1, T2	max. 2000	P5, P1	No code, W2, Wx
			15	Standard	No code, R	T0, T1, T2	max. 2000	P5, P1	No code, W2, Wx
				Extended	No code, R	T0, T1, T2	max. 2000	P5, P1	No code, W2, Wx

¹⁾ For detail information about the complete ordering key, please have a look at **chapter 5**.

²⁾ Rails manufactured as cut to length items might not be able to be delivered with the max. length due to the E dimension.

Ordering and designation example:

System 1: LLSHS9TA2T0-260P5/E0

System 1: LLSHS12LAR3T1-850P1/W2E10

1.6 Miniature guide applications

Laboratory analysers – Medical industry

Liquid handling and probe loading at chemical or biomedical analysers for testing blood, or other human or veterinary materials

Why miniature profile rail guides LLS:

- Nearly no maintenance, when pre-lubricated
- Low noise in office environment
- Smooth running for precise motion
- Up to 20000 km of service life



Mini slides - Automation industry

For secure positioning with mini slides in automation applications of pick and place or testing. Used as a guide element to support pneumatic slide function.

Why miniature profile rail guides LLS:

- High rigidity due to optimized carriage design
- High performance with new ball recirculation
- Long seal life with highly abrasive resistant material
- Most failproof and quick mounting



3D printing – Additive manufacturing

Precise manufacturing of parts in 3D printers. Linear guide for y-z motion of the printing nozzle and exact positioning of the printing plate.

Why miniature profile rail guides LLS:

- High performance in acceleration for productivity
- Smooth running at low friction for high precision
- Low noise for office environments
- Stainless steel material for corrosion resistance



Dental imaging – Medical industry

Allows elliptical rotation function of the imaging device around the patient head, while the collimator is automatically shielding the x-ray beam.

Why miniature profile rail guides LLS:

- Silent motion for medical applications
- Corrosion resistance with stainless steel material
- Factory pre-lubricated and ready to use
- Secure and safe mounting with robust ball retention



CNC milling machine – Machine tool

Small 3-axis CNC milling machine with miniature profile rail guides to realize precise accurate motion for the production of small work pieces.

Why miniature profile rail guides LLS:

- Secure and safe mounting with robust ball retention
- Rigid guide system with high performance
- High position accuracy with low friction
- Sealed guide system for long life



Tonometer – Ophthalmic industry

To detect fluid pressure inside the eyes, a non-contact tonometer is often used with an automatic detection function based on linear guides.

Why miniature profile rail guides LLS:

- Maintenance-free operation
- Precise guiding with low friction
- Clean components made from stainless steel
- Smooth running with high repeatability



Automated optical inspection (AOI) – Electronic industry

Two camera system adjustable with miniature guides allowing a two-side inspection of circuit boards placed at the conveyer belt system while passing the machine.

Why miniature profile rail guides LLS:

- Maintenance-free with up to 20000 km of service life
- High performance with acceleration and speed
- High rigidity paired with low friction motion
- Stainless steel metal components for cleanliness



Dental CAD-CAM – Medical industry

Production of prosthetics at the dental office or in a laboratory after imaging patient data. The patient data deliver the input for the milling process.

Why miniature profile rail guides LLS:

- Sealed guide system with low friction
- High position accuracy with smooth motion
- Up to 20000 km of service life
- Easy and safe mounting for high accuracy



2

Selection guide

2.1 Technical data



2.1.1 Load ratings

The load ratings stated in this catalogue have been calculated for all products based on the ISO 14728 standards. The calculation model prescribed in these standards has been complemented and verified by Ewellix through internal simulations.

Basic dynamic load rating

The basic dynamic load rating C is the radial load, constant in magnitude and direction, which a linear rolling bearing can theoretically accommodate for a basic rating life represented by a travelled distance of 100 km. All Ewellix linear guides load ratings are based on 100 km travel distance. According to ISO 14728, it is also possible to define a reference travel distance of 50 km. In this case, a conversion factor should be applied in order to enable proper comparison of the two load rating values (↳ **formula 1**).

$$(1) \quad C = C_{100} = \frac{C_{50}}{1,26} \quad (\text{for ball guided systems})$$

where

- C = dynamic load rating (N)
- C₁₀₀ = dynamic load rating for 100 km travel distance (N)
- C₅₀ = dynamic load rating for 50 km travel distance (N)

Basic static load rating

The basic static load rating C₀ is the static load in the direction of loading which corresponds to a calculated stress at the centre of the most heavily loaded contact point between the rolling element and each of the raceways of carriage and rail. This stress produces a permanent total deformation of the rolling element and the raceway of approximately 0,0001 times of the rolling element diameter.

Table 1

Load ratings

Range	Size	Standard carriage TA, TAR		Extended length carriage LA, LAR	
		C N	C ₀ N	C N	C ₀ N
Standard LLSH	7	915	1460	1270	2400
	9	1700	2800	2280	4300
	12	2500	3900	3550	6300
	15	3900	5850	5500	9800
Wide LLSW	7	1220	2200	1660	3450
	9	2160	4050	2850	5850
	12	3100	5300	4250	8300
	15	5000	8500	6550	12500

2.1.2 Preload classes

To adjust a profile rail guide to the specific requirements of a given application, it is advisable to choose an appropriate preload. Preload can enhance the performance of an entire linear guidance system and increase the rigidity of the carriage under load.

Preload is reached by using oversized rolling elements between carriage and rail raceways. The determination of the appropriate preload depends on the operation conditions. The preload class is mainly influencing the carriage rigidity and friction.

Ewellix recommends T0 preload class for applications with smooth running performance and low friction. For applications characterized by shock loads, vibration and alternating loads or torques, it is advisable to select the T1 preload class. The maximum preload T2 class is advisable to use only on the highest rigidity, torque or vibration demands regardless of the friction. In that case, Ewellix recommends you contact your local service partner for more detailed technical advice and support.

Fig. 1

Generation of preload

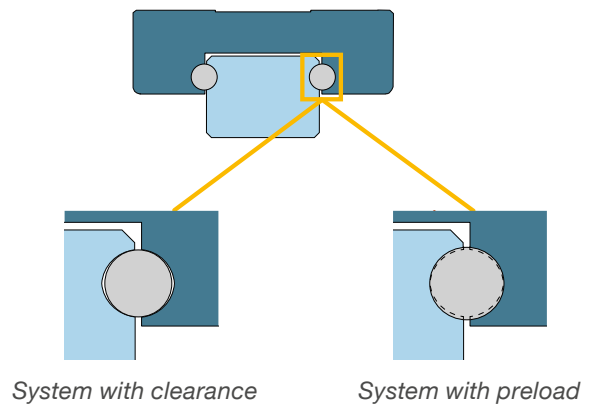

Table 2

Preload class	Characteristics	Preload force
T0	Light clearance, best smoothness running and lowest friction	$F_{Pr} = 0 \% \text{ of } C$
T1	Light preload, good smooth running and preloaded	$F_{Pr} = 2 \% \text{ of } C$
T2	Medium preload, higher preload force and rigidity	$F_{Pr} = 8 \% \text{ of } C$

2.1.3 Precision classes

Precision classes

Ewellix offers LLS miniature profile rail guides in two precision classes. These precision classes define the maximum tolerance range of a profile rail system in terms of height, width and running parallelism. This choice determines the running accuracy of the system within the application (↳ **table 3** and **diagram 1**).

When performing measurements of height, width or running parallelism, any clearance between rail and carriage has to be eliminated or controlled in a suitable way to get correct results.

Running parallelism

The running parallelism P_a is the tolerance between the two reference planes of the rail and carriage when the carriage is moved along the entire rail length, the rail being screwed to the reference plane. Please refer to **figure 2** and **diagram 1** for detailed information.

Fig. 2

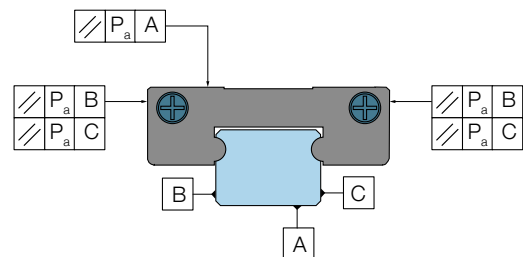
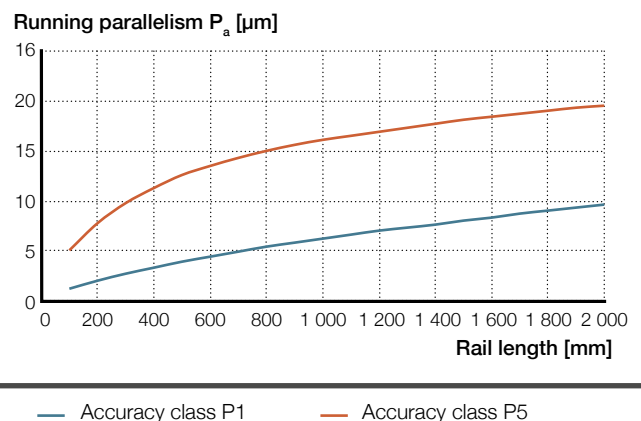

Diagram 1



Width and height precision

The dimension N determines the maximum deviation in width from the carriage to the rail in lateral direction. Both sides of the rail and the carriage can be used as the reference side (→ fig. 3).

The dimension H determines the maximum deviation in height between the mounting surface of the carriage and the ground bottom surface of the rail (→ fig. 3).

The tolerances H and N in table 3 are valid for any carriage on any rail using ZRC components or between single systems (→ fig. 4). The deviations ΔH and ΔN result, when multiple carriages are mounted on the same rail at one position (→ fig. 5).

If the height deviation between systems is very important for an application, Ewellix is proposing to order parallel mounted rails. When ordering the rail arrangement "Wx" of parallel mounted rails, the height deviation ΔH is kept between different systems.

Combination of rails and carriages

All ZRC range carriages and rails of the same size in precision class P5 can be combined with each other while maintaining precision class P5. They are fully interchangeable. Precision class P1 can be delivered as a mounted system only.

Fig. 3

Definition of N and H

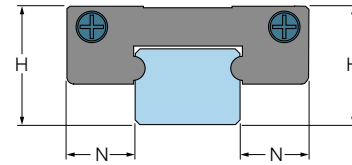

Fig. 4

For any combination of carriages and rails

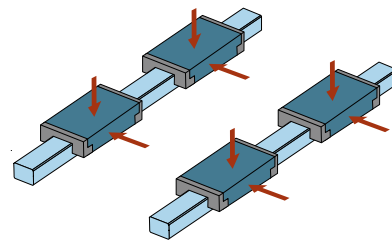

Fig. 5

For different carriages on the same rail position

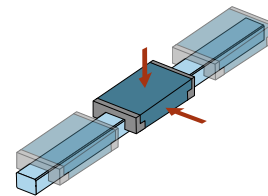

Table 3

Precision class	Tolerance between ZRC components or single systems ¹⁾		Dimensional deviations of carriages on the same rail		Dimensional deviations on parallel mounted rails (Wx)
	Any carriage on any rail		Multiple carriages on same rail at one position		Multiple carriages on number of ordered systems at one position
	H	N	ΔH	ΔN	ΔH
-	μm				
P5	±20	±25	15	15	15
P1	±10	±15	7	7	7

¹⁾ Measured at the center in length direction at both carriage surfaces

2.1.4 Rigidity

The rigidity of LLS miniature profile rail guides, in addition to their load carrying capacity, is an important criteria for product selection.

Rigidity can be defined as the deformation characteristics of a guidance system under external load. The rigidity of a system depends on the magnitude and direction of the external load, the type of guidance system (size, carriage type, preload) and the mechanical properties of the adjacent support structure.

The elasticity of the support structure, the screw connections and the joints between components impacts the overall rigidity at the bearing point.

Therefore, the overall rigidity at the bearing point is lower than that of the used guiding system.

The deformation behavior in top load direction of an LLS miniature profile rail guide system can be selected by the following diagrams (↳ **diagram 2 to 9**).

Rigidity values given in the diagrams are valid for one carriage of the shown types, for data on other types please contact Ewellix.

Diagram 2

Deformation for standard size LLSH 7 TA

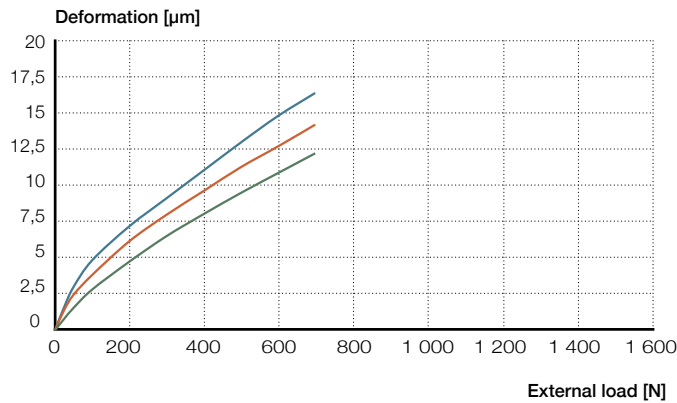

— LLSHS 7 TA T0 — LLSHS 7 TA T1 — LLSHS 7 TA T2

Diagram 3

Deformation for standard size LLSH 9 TA

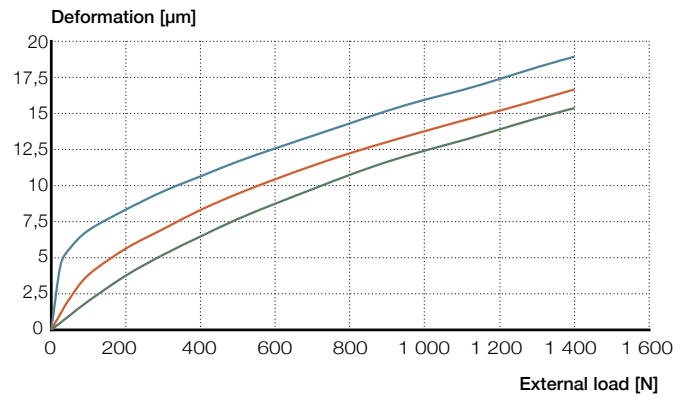

— LLSHS 9 TA T0 — LLSHS 9 TA T1 — LLSHS 9 TA T2

Diagram 4

Deformation for standard size LLSH 12 TA

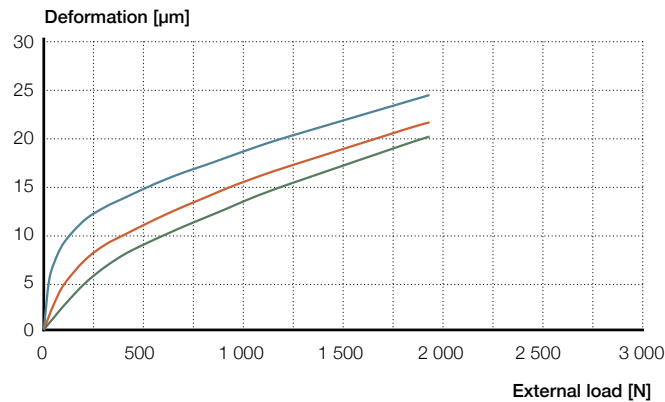

— LLSHS 12 TA T0 — LLSHS 12 TA T1 — LLSHS 12 TA T2

Diagram 5

Deformation for standard size LLSH 15 TA

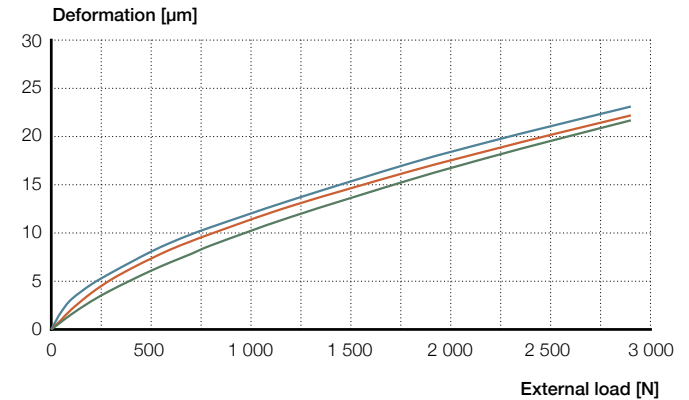

— LLSHS 15 TA T0 — LLSHS 15 TA T1 — LLSHS 15 TA T2

Diagram 6

Deformation for standard size LLSW 7 TA

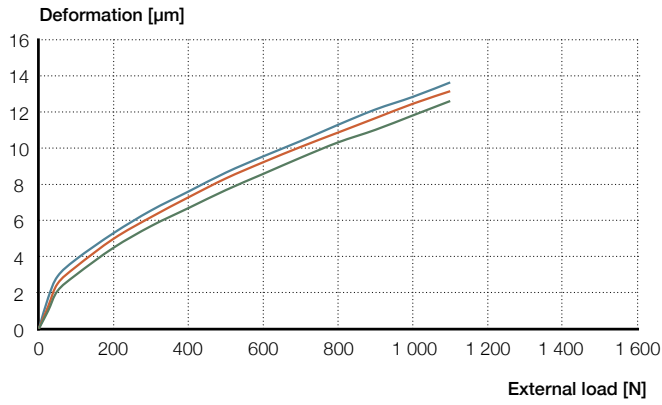

— LLSWS 7 TA T0 — LLSWS 7 TA T1 — LLSWS 7 TA T2

Diagram 7

Deformation for standard size LLSW 9 TA

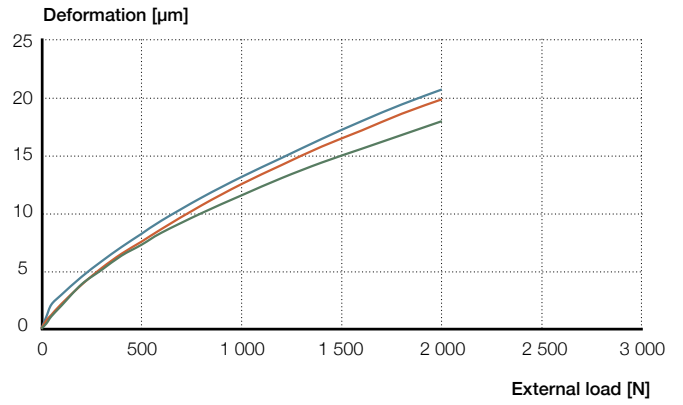

— LLSWS 9 TA T0 — LLSWS 9 TA T1 — LLSWS 9 TA T2

Diagram 8

Deformation for standard size LLSW 12 TA

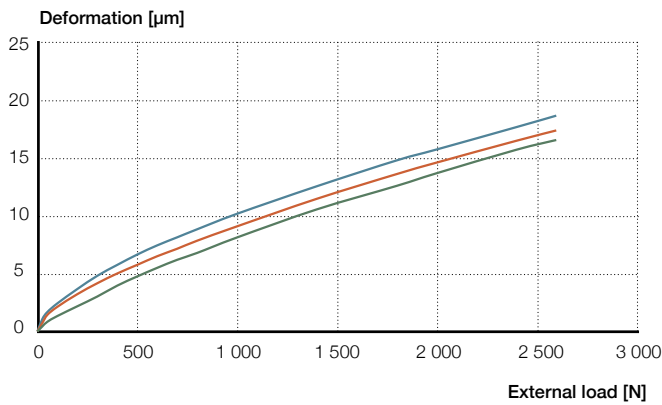

— LLSWS 12 TA T0 — LLSWS 12 TA T1 — LLSWS 12 TA T2

Diagram 9

Deformation for standard size LLSW 15 TA

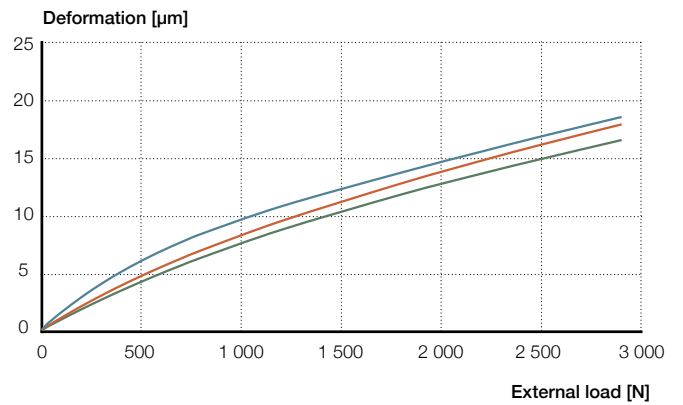

— LLSWS 15 TA T0 — LLSWS 15 TA T1 — LLSWS 15 TA T2

2.1.5 Performance data

The function of LLS miniature profile rail guides can be ensured if they are used inside the limits of the below performance parameters. The dimensioning and calculations of miniature profile rails are valid when operating within these conditions.

Table 4

Performance	
Speed	5 m/s
Acceleration	140 m/s ²
Preload class	T0, T1, T2
Accuracy class	P5, P1
Temperature (shielded)	-20° to + 100° C
Temperature (sealed)	-20° to + 80° C
Maximum load	< 0,5 C
Minimum load	> 0,001 C

Table 5

Material	
Rail	Stainless steel, hardened
Carriage body	Stainless steel, hardened
Balls	Stainless steel, hardened
Ball recirculation	POM
Ball retention	Stainless steel
Seal	Elastomer, POM
Shield	POM
Lubrication reservoir	Foamed material
Factory lubrication with	Klüber Paraliq P 460
Compliance with	RoHS, REACH

Speed and acceleration

LLS miniature profile rail guides can be used up to a maximum speed of

$$v_{max} = 5 \text{ m/s}$$

and a maximum acceleration of

$$a_{max} = 140 \text{ m/s}^2$$

For applications with high acceleration, Ewellix is recommending a higher load than the minimum requested load or the use of preloaded carriages. Otherwise, the service life might be shorter than expected.

Minimum load

To ensure the slip-free running of profile rail guides, they must be subjected to a certain minimum load. The general guideline is a minimum value of $P = 0,001 \text{ C}$. The minimum load is of special importance in profile rail guides which operate at high speed or with high acceleration. In such cases, the inertia forces of the balls as well as the rolling friction in the lubricant can have an adverse effect on the rolling conditions in the guide and can lead to damaging slip conditions between the balls and raceways

Maximum load

According to ISO 14728, Part 1, the calculation of bearing life is correct only when the equivalent dynamic load of a profile rail guide does not exceed 50% of the dynamic load rating C . In addition, the maximum load should never exceed 50% of the static load rating C_0 , as stated in ISO 14728, Part 2.

Higher loads lead to an imbalance of stress distribution which can have a negative effect on bearing life. In case such conditions occur, please seek advice from your local Ewellix support team.

Operating temperature

The permissible temperature range for LLS miniature profile rail guides is:



Carriages with protection shields

-20 to 100 °C for continuous operation



Carriages with low friction front seals

-20 to +80 °C for continuous operation

In case you use your own choice of lubricant, be sure to check prior to use that the temperature limits of the lubricant can withstand elevated temperatures.

When planning to use the linear guide carriages outside the given temperature range, please get in contact with the Ewellix support team.

2.1.6 Friction

The friction in a guidance system is determined by a number of factors. For example, the preload class, external loads, speed of travel and viscosity of the lubricant should be taken into consideration.

Another factor is the sliding friction of the front seals in contact with the profile rail. The friction generated by the seals will, however, decrease after the running-in phase. The friction can be reduced to a minimum when shielded carriages are used. Due to the gap sealing ability, shielded carriages should only be considered for applications in clean environments.

Moreover, the mounting precision of the rails relative to each other plays an important part, just like the flatness of the carriage mounting plate or the evenness of the rail mounting surface.

The coefficient of friction for lubricated profile rail guides is typically between $\mu = 0,003$ and $0,005$. Lower values are valid for higher loads, and higher values for lower loads. The different friction forces for miniature profile rails are shown in **tables 6 and 7**.

Table 6

Friction force of a **shielded** carriage with standard grease, precision class P5 or P1

Range	Size	Carriage type	Running friction force (N) max. per preload class		
			T0	T1	T2
Standard LLSHS	7	Standard length TA	0,7	1,4	2,7
		Extended length LA	0,7	1,4	2,7
	9	Standard length TA	0,7	1,4	2,7
		Extended length LA	0,7	1,4	2,7
	12	Standard length TA	0,8	1,5	2,8
		Extended length LA	0,8	1,5	2,8
15	Standard length TA	0,9	1,5	2,8	
	Extended length LA	0,9	1,5	2,8	
	Standard length TA	0,9	1,5	2,8	
Wide LLSWS	7	Standard length TA	0,7	1,7	3,2
		Extended length LA	0,7	1,7	3,2
	9	Standard length TA	0,7	1,7	3,2
		Extended length LA	0,7	1,7	3,2
	12	Standard length TA	0,8	2,2	4,3
		Extended length LA	0,8	2,2	4,3
	15	Standard length TA	0,9	3,0	4,3
		Extended length LA	0,9	3,0	4,3
		Standard length TA	0,9	3,0	4,3

Table 7

Friction force of a **sealed** carriage with standard grease, precision class P5 or P1

Range	Size	Carriage type	Running friction force (N) max. per preload class		
			T0	T1	T2
Standard LLSHS	7	Standard length TA	1,0	1,7	3,0
		Extended length LA	1,0	1,7	3,0
	9	Standard length TA	1,0	1,7	3,0
		Extended length LA	1,0	1,7	3,0
	12	Standard length TA	1,1	1,8	3,1
		Extended length LA	1,1	1,8	3,1
15	Standard length TA	1,2	1,8	3,1	
	Extended length LA	1,2	1,8	3,1	
	Standard length TA	1,2	1,8	3,1	
Wide LLSWS	7	Standard length TA	1,0	2,0	3,5
		Extended length LA	1,0	2,0	3,5
	9	Standard length TA	1,0	2,0	3,5
		Extended length LA	1,0	2,0	3,5
	12	Standard length TA	1,1	2,5	4,6
		Extended length LA	1,1	2,5	4,6
	15	Standard length TA	1,2	3,3	4,6
		Extended length LA	1,2	3,3	4,6
		Standard length TA	1,2	3,3	4,6

NOTE: All information presented by Ewellix with regard to running friction force is based on the validation result without load with lubricant viscosity grade 460 under room temperature..

2.2 Selection of profile rail guides

The selection process for a suitable linear guide system is recommended to be done according to the following steps:

- a. External force calculation (↳ [chapter 2.2.4](#))
- b. Selection of suitable type (↳ [chapter 3.1](#))
- c. Bearing load calculations (↳ [chapter 2.2.3](#))
- d. Rating life calculation (↳ [chapter 2.2.1](#))
- e. Static safety factor calculation (↳ [chapter 2.2.5](#))

During this process, decisions on preload and precision class must be made as well as rigidity and performance data that must be checked. (↳ [chapter 2.1](#))

Ewellix will explain the process by starting with the rating life followed by the influence factors, then explaining the bearing loads and external force calculations to finally reach the static calculation.

Linear guide on-line calculation tool

Ewellix is supporting the total calculation process from external forces to bearing loads, rating life and static safety factors with the linear guide calculator e-tool. The online calculation tool is free of charge, please follow the **QR code** link below. For more information, please have a look at [chapter 2.2.6](#).



[Linear guides select](#)

2.2.1 Rating life

The rating life of a linear guide with rolling elements is defined as the total linear distance travelled by the linear guide before the first sign of material fatigue occurs at raceways or with rolling elements. For the selection of a linear guide based on rating life calculations, the dynamic load rating C should be used. It is expressed as the load that results in a bearing life of 100 km travel distance. To learn about the influence on other travel distances, at rating life calculations, please see [chapter 2.1.1](#).

The basic rating life L is defined as 90 % of a large group of identical linear bearings under the same conditions that are expected to exceed or attain a travel distance of 100 km.

When all loads and motion parameters are known, the basic rating life of the selected linear guide can be calculated in kilometers or operating hours using the following formula:

$$(2) \quad L = 100 \cdot \left(\frac{C}{P} \right)^p$$

$$(3) \quad L_h = \frac{5 \cdot 10^7}{S_{\sin} \cdot n \cdot 60} \left(\frac{C}{P} \right)^p$$

The basic rating life might be different taking all design and load conditions of an application into consideration. Also, the factors of influence described in [chapter 2.2.2](#) must be detected. With that information, the modified rating life can be calculated as follows:

$$(4) \quad L = 100 f_s \left(\frac{f_i \cdot C}{f_d \cdot F_{\text{res}}} \right)^p$$

where:

L = modified basic rating life [km]

L_h = modified basic rating life [h]

C = dynamic load rating [N]

P = equivalent dynamic load [N]

p = life exponent; $p = 3$ for balls

n = stroke frequency [double strokes/min]

S_{\sin} = single stroke length [mm]

f_i = factor for bearing distance

f_s = factor for stroke length

f_d = factor for load conditions

F_{res} = resulting load [N] (↳ [chapter 2.2.3](#))

100 = basic travel distance [km]

Ewellix recommends that to calculate the basic rating life for the carriage with the highest load, equation (4) can be directly used, when the load is constant in magnitude and direction. If the load and motion conditions vary, they must be split up in sequences with average load conditions as shown in **chapter 2.2.3**.

NOTE: According to ISO 14728, the rating life calculation is only valid if the dynamic load P does not exceed 50 % of the dynamic load rating C.

Service life

Compared to the calculated rating life, the service life describes the travel distance a linear guiding remains operational under the real application conditions. The service life might be higher or lower than the calculated rating life. That depends very much on:

- Proportion of material wear out
- Environmental conditions like temperature
- Contamination and seal functionality
- Correct lubrication and oil viscosity
- Stress and loads from misalignments
- Unknown loads or other forces or vibrations

If needed, the service life can be quantified under real machine test conditions or by comparison with similar applications.

2.2.2 Influence factors

The factors of influence are correcting the impact of design, motion and load conditions on the calculated rating life. Vast application experience and various test have resulted in the definition of the correction factors.

Stroke length factor

Strokes that are shorter than the carriage length have a negative impact on the achievable service life. If the stroke S is longer than the carriage length, the stroke length factor $f_s = 1$.

When the ratio between stroke S to carriage length L_2 (→ **fig. 6**) is lower than 1,0, the stroke length factor can be taken from **table 8**.

Sub strokes at sequenced load phases with identical moving direction can be added together to one sub stroke S. For each sequenced load phase, the right factor f_s must be applied.

Table 8

Factor f_s for stroke length	
S/L_2	f_s
1,0	1,0
0,9	0,91
0,8	0,82
0,7	0,73
0,6	0,63
0,5	0,54
0,4	0,44
0,3	0,34
0,2	0,23

Load condition factor

The load acting on a linear guide is resulting from acceleration, impact loads and vibration. Often it is difficult to quantify these additional dynamic forces exactly. For that reason, the load must be multiplied by factor f_d .

Depending on the speed or mean speed and strength of the impact load as well as on the vibrations which are relevant for the application, the values for f_d can be taken from **table 9**.

Table 9

Load conditions	Factor f_d for load conditions	
	from	up to
Smooth operation, no or light impact loads Speed ≤ 2 m/s	1,0	1,5
High impact loads Speed > 2 m/s	1,5	3,0

Bearing distance factor

Most linear guide applications use two or more carriages on one rail to distribute load. The load distribution on the carriages is strongly influenced by the carriage distance c (→ **fig. 6**) and the manufacturing quality of the adjacent components.

The bearing distance factor f_i takes the influences on carriage load distribution into account based on the number of carriages per rail and their distance relative to each other (→ **table 10** and **fig. 6**)

Table 10

Number of carriages	Factor f_i for bearing distance	
	If $c \geq 1,5 \cdot L_2$	If $c < 1,5 \cdot L_2$
1	1	1
2	1	0,81
3	1	0,72

Fig. 6

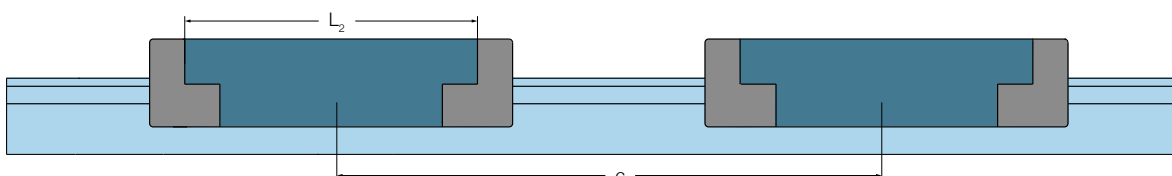

2.2.3 Dynamic bearing loads

To calculate the dynamic bearing load, all loads and forces acting on the linear guide system must be taken into consideration. When load is constant in size, F_{res} or F_{comb} might be used to get the expected rating life. For most applications, different load phases and stroke sequences are the reality. In these cases, an equivalent dynamic mean load has to be determined to be used in the life calculation.

Equivalent dynamic mean load

For the equivalent dynamic mean load P_m , the various load and motions have to be separated into load phases with constant or approximately constant conditions along their individual strokes ((\rightarrow **diagram 10**). All single load phases are summarized by the equivalent dynamic mean load depending on their individual stroke length. For each individual phase the factor for load condition as well as the factor for stroke length might be different and have to be determined accordingly. Normally, the factor of bearing distance stays constant during all load phases. ((\rightarrow **formulae 5, 6 and 7**).

$$(5) \quad P_m = \sqrt[p]{\frac{\sum_{j=1}^V |P_j^p| \cdot S_j}{S_{tot}}}$$

$$(6) \quad S_{tot} = S_1 + S_2 + S_3 + \dots + S_j + \dots + S_v$$

$$(7) \quad P_j^p = \frac{F_{res,j}^p \cdot f_{d,j}}{f_i \cdot f_{s,j}^{1/p}}$$

where

- P_m = equivalent dynamic mean load [N]
- P_j = equivalent dynamic load of load phase [N]
- j = counter of load phase
- V = number of load phase
- S_j = stroke length of load phase [mm]
- $f_{d,j}$ = factor for load conditions of load phase
- $f_{s,j}$ = factor for stroke length of load phase
- f_i = factor for bearing distance
- $F_{res,j}$ = resulting load of load phase j [N]
- S_{tot} = total stroke length [mm]
- p = life exponent; $p = 3$ for balls

Diagram 10

Variable load acting on a linear bearing

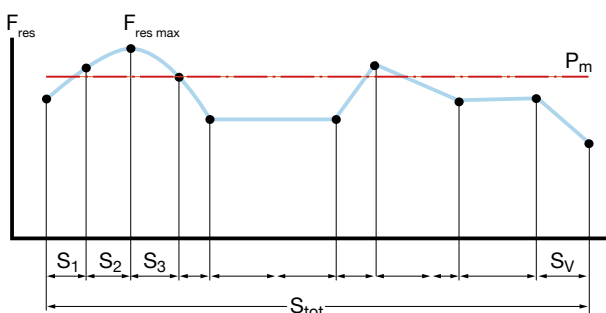

Resulting load and preload influence

The resulting load F_{res} for the total stroke or per load phase depends on the combined bearing load F_{comb} and the chosen preload class of the linear guide system. For linear guides with T0 preload, class F_{res} is equal to F_{comb} .

For preloaded systems, the preload force F_{Pr} has to be detected and taken into consideration according to the following differentiated load cases in **formula 8**.

$$(8a) \quad F_{res} = F_{comb} \quad \text{if } F_{comb} > 2,8 F_{Pr}$$

or

$$(8b) \quad F_{res} = \left(\frac{F_{comb}}{2,8 \cdot F_{Pr}} + 1 \right)^{1,5} F_{Pr} \quad \text{if } F_{comb} \leq 2,8 F_{Pr}$$

where

- F_{comb} = combined, static or dynamic bearing load [N]
- F_{Pr} = preload force [N]
- F_{res} = resulting load [N]

Table 11

Preload class	Preload force F_{Pr}
T0	$F_{Pr} = 0 \%$ of C
T1	$F_{Pr} = 2 \%$ of C
T2	$F_{Pr} = 8 \%$ of C

Combined bearing load

To calculate the combined bearing load F_{comb} , all bearing loads must be considered. All load components must be constant in magnitude to enable their calculation as one load phase. If one of the load proportions varies significantly in magnitude over the length of the stroke, a separate load phase must be created (→ **diagram 10**). F_{comb} is used to calculate the resulting load F_{res} . The calculation formula is different depending on the chosen linear guide configuration. Normally the most loaded bearing point or carriage has to be taken into consideration for the calculation.

Configuration 24

Linear guide system with 2 carriages on each of the 2 guide rails

(9a) $F_{comb} = |F_y| + |F_z|$

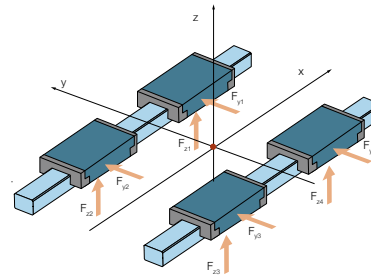

Configuration 12

Linear guide system with 2 carriages on 1 guide rail

(9b) $F_{comb} = |F_y| + |F_z| + C \left(\frac{M_x}{M_{xC}} \right)$

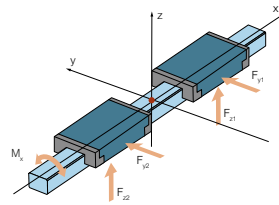

Configuration 22

Linear guide system with 1 carriage on each of the 2 guide rails

(9c) $F_{comb} = |F_y| + |F_z| + C \left(\left| \frac{M_y}{M_{yC}} \right| + \left| \frac{M_z}{M_{zC}} \right| \right)$

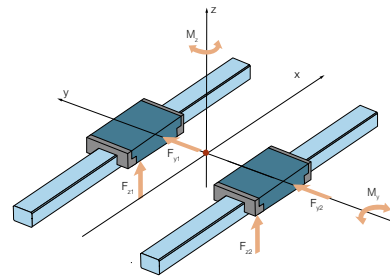

Configuration 11

Linear guide system with 1 carriage on 1 guide rail

(9d) $F_{comb} = |F_y| + |F_z| + C \left(\left| \frac{M_x}{M_{xC}} \right| + \left| \frac{M_y}{M_{yC}} \right| + \left| \frac{M_z}{M_{zC}} \right| \right)$

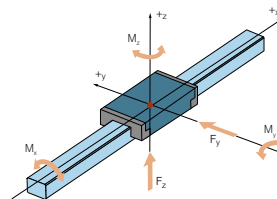

where

- F_{comb} = combined bearing load
- F_y = bearing load in y-direction [N]
- F_z = bearing load in z-direction [N]
- C = dynamic load rating [N]
- M_x = bearing torque load of x-axis [Nmm]
- M_y = bearing torque load of y-axis [Nmm]
- M_z = bearing torque load of z-axis [Nmm]
- M_{xC} = torque load rating of x-axis [Nmm]
- M_{yC} = torque load rating of y-axis [Nmm]
- M_{zC} = torque load rating of z-axis [Nmm]

2.2.4 External force calculation

The external force calculation is the translation of all loads to the bearing points. According to the selected linear guide configuration, the formulas for load determination are shown in this chapter. All loads acting on the guiding system must be broken down into the proportions F_{x_i} and F_{z_i} . These proportions are then inserted into the respective formula.

Configuration 24

Loads on a system with 2 guide rails and 4 carriages

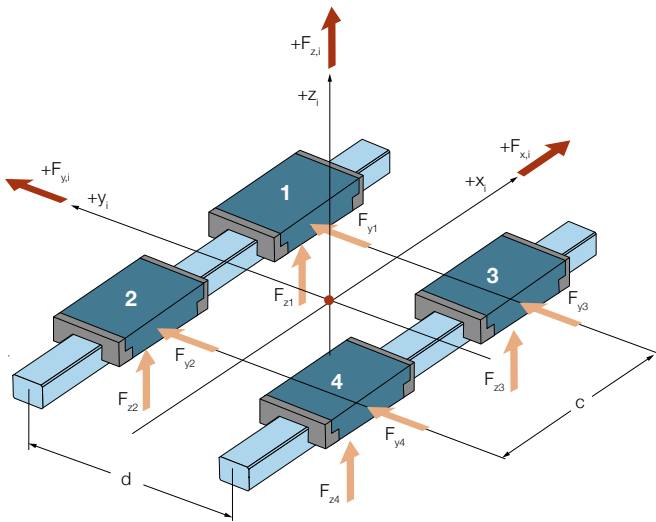

Carriage Formula

1	Bearing load in z-direction $F_{z1} = \frac{\sum_{i=1}^U F_{z,i}}{4} + \frac{\sum_{i=1}^U (F_{z,i} \cdot y_i) - \sum_{i=1}^U (F_{y,i} \cdot z_i)}{2 \cdot d} + \frac{\sum_{i=1}^U (F_{z,i} \cdot x_i) - \sum_{i=1}^U (F_{x,i} \cdot z_i)}{2 \cdot c}$
2	Bearing load in z-direction $F_{z2} = \frac{\sum_{i=1}^U F_{z,i}}{4} + \frac{\sum_{i=1}^U (F_{z,i} \cdot y_i) - \sum_{i=1}^U (F_{y,i} \cdot z_i)}{2 \cdot d} + \frac{\sum_{i=1}^U (F_{x,i} \cdot z_i) - \sum_{i=1}^U (F_{z,i} \cdot x_i)}{2 \cdot c}$
3	Bearing load in z-direction $F_{z3} = \frac{\sum_{i=1}^U F_{z,i}}{4} + \frac{\sum_{i=1}^U (F_{y,i} \cdot z_i) - \sum_{i=1}^U (F_{z,i} \cdot y_i)}{2 \cdot d} + \frac{\sum_{i=1}^U (F_{z,i} \cdot x_i) - \sum_{i=1}^U (F_{x,i} \cdot z_i)}{2 \cdot c}$
4	Bearing load in z-direction $F_{z4} = \frac{\sum_{i=1}^U F_{z,i}}{4} + \frac{\sum_{i=1}^U (F_{y,i} \cdot z_i) - \sum_{i=1}^U (F_{z,i} \cdot y_i)}{2 \cdot d} + \frac{\sum_{i=1}^U (F_{x,i} \cdot z_i) - \sum_{i=1}^U (F_{z,i} \cdot x_i)}{2 \cdot c}$
1/3	Bearing load in y-direction $F_{y1} = F_{y3} = \frac{\sum_{i=1}^U F_{y,i}}{4} + \frac{\sum_{i=1}^U (F_{y,i} \cdot x_i) - \sum_{i=1}^U (F_{x,i} \cdot y_i)}{2 \cdot c}$
2/4	Bearing load in y-direction $F_{y2} = F_{y4} = \frac{\sum_{i=1}^U F_{y,i}}{4} - \frac{\sum_{i=1}^U (F_{y,i} \cdot x_i) - \sum_{i=1}^U (F_{x,i} \cdot y_i)}{2 \cdot c}$

Configuration 12

Loads on a system with 1 guide rail and 2 carriages

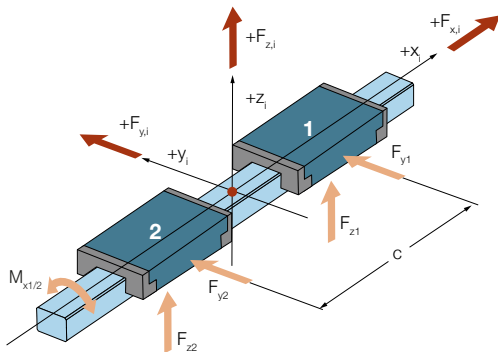

Carriage Formula

1	Bearing load in z-direction $F_{z1} = \frac{\sum_{i=1}^U F_{z,i}}{2} - \frac{\sum_{i=1}^U (F_{x,i} \cdot z_i) - \sum_{i=1}^U (F_{z,i} \cdot x_i)}{c}$
2	Bearing load in z-direction $F_{z2} = \frac{\sum_{i=1}^U F_{z,i}}{2} + \frac{\sum_{i=1}^U (F_{x,i} \cdot z_i) - \sum_{i=1}^U (F_{z,i} \cdot x_i)}{c}$
1	Bearing load in y-direction $F_{y1} = \frac{\sum_{i=1}^U F_{y,i}}{2} - \frac{\sum_{i=1}^U (F_{x,i} \cdot y_i) - \sum_{i=1}^U (F_{y,i} \cdot x_i)}{c}$
2	Bearing load in y-direction $F_{y2} = \frac{\sum_{i=1}^U F_{y,i}}{2} + \frac{\sum_{i=1}^U (F_{x,i} \cdot y_i) - \sum_{i=1}^U (F_{y,i} \cdot x_i)}{c}$
1/2	Bearing torque load of x-axis $M_{x1} = M_{x2} = \frac{-\sum_{i=1}^U (F_{y,i} \cdot z_i) + \sum_{i=1}^U (F_{z,i} \cdot y_i)}{2}$

Configuration 22

Loads on a system with 2 guide rails and 2 carriages

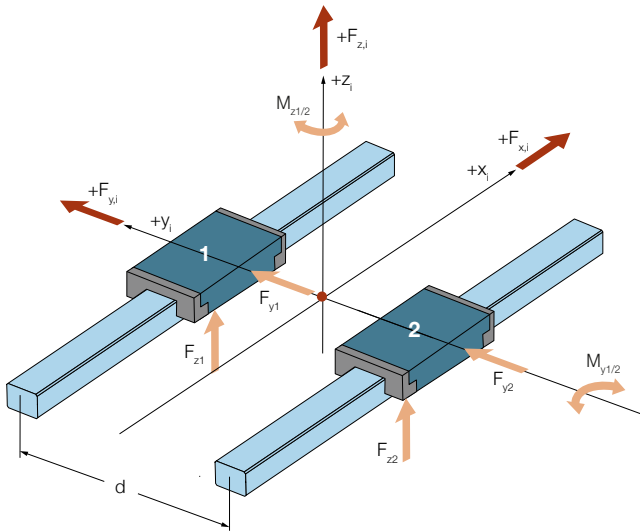

Carriage	Formula
1	Bearing load in z-direction $F_{z1} = \frac{\sum_{j=1}^U F_{z,j}}{2} - \frac{\sum_{j=1}^U (F_{y,j} \cdot z_j) - \sum_{j=1}^U (F_{z,j} \cdot y_j)}{d}$
2	Bearing load in z-direction $F_{z2} = \frac{\sum_{i=1}^U F_{z,i}}{2} + \frac{\sum_{i=1}^U (F_{y,i} \cdot z_i) - \sum_{i=1}^U (F_{z,i} \cdot y_i)}{d}$
1/2	Bearing load in y-direction $F_{y1} = F_{y2} = \frac{\sum_{i=1}^U F_{y,i}}{2}$
1/2	Bearing torque load of y-axis $M_{y1} = M_{y2} = \frac{\sum_{i=1}^U (F_{x,i} \cdot z_i) - \sum_{i=1}^U (F_{z,i} \cdot x_i)}{2}$
1/2	Bearing torque load of z-axis $M_{z1} = M_{z2} = \frac{-\sum_{i=1}^U (F_{x,i} \cdot y_i) + \sum_{i=1}^U (F_{y,i} \cdot y_i)}{2}$



Configuration 11

Loads on a system with 1 guide rail and 1 carriage

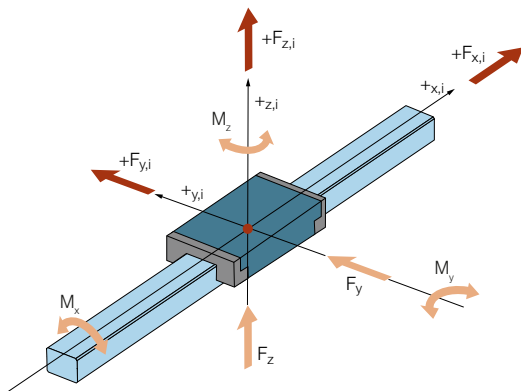

Carriage	Formula
1	Bearing load in z-direction $F_z = \sum_{i=1}^U F_{z,i}$
1	Bearing load in y-direction $F_y = \sum_{i=1}^U F_{y,i}$
1	Bearing torque load of x-axis $M_x = -\sum_{i=1}^U (F_{y,i} \cdot z_i) + \sum_{i=1}^U (F_{z,i} \cdot y_i)$
1	Bearing torque load of y-axis $M_y = \sum_{i=1}^U (F_{x,i} \cdot z_i) - \sum_{i=1}^U (F_{z,i} \cdot x_i)$
1	Bearing torque load of z-axis $M_z = -\sum_{i=1}^U (F_{x,i} \cdot y_i) + \sum_{i=1}^U (F_{y,i} \cdot x_i)$

Table 12

Bearing centre point

H _{ct} Values	
Type	mm
LLSHS 7 TA / LA	4,6
LLSHS 9 TA / LA	5,1
LLSHS 12 TA / LA	6,5
LLSHS 15 TA / LA	9,0
LLSWS 7 TA / LA	5,1
LLSWS 9 TA / LA	7,0
LLSWS 12 TA / LA	7,9
LLSWS 15 TA / LA	9,0

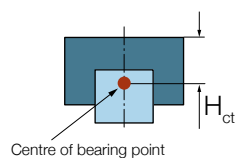

where:

- F_{y1} to F_{y4} = bearing load in y-direction at each bearing [N]
- F_{z1} to F_{z4} = bearing load in z-direction at each bearing [N]
- M_{1x}, M_{2x} = bearing torque load of x-axis [Nmm]
- M_{1y}, M_{2y} = bearing torque load of y-axis [Nmm]
- M_{1z}, M_{2z} = bearing torque load of z-axis [Nmm]
- F_{x,i}, F_{y,i}, F_{z,i} = external loads and accelerations in each direction [N]
- x_i, y_i, z_i = lever arms of external loads [mm]
- i = counter for external loads
- U = number of loads that act simultaneously

2.2.5 Static bearing load

The static bearing load is the vertical load acting on a bearing point when the linear guide system is not in motion (↳ Fig. 7). For the static safety factor, the most loaded bearing point has to be checked against the static load rating. For that safety factor calculation it does not matter if the maximum load results from a static or dynamic impact. The maximum resulting force $F_{res\ max}$ has to be elaborated in the same way as the external force calculation and the dynamic bearing load determination in **chapter 2.2.4**. The results are used for the equivalent static bearing load.

Equivalent static bearing load

The maximum load P_{max} must include all forces acting on the bearing point. It is the point with the maximum resulting load $F_{res\ max}$ (↳ diagram 10, chapter 2.2.3) and must include the load condition factor as well as the preload calculation in **chapter 2.2.3** and can be calculated as follows.

$$(10) \quad P_{max} = f_d \cdot F_{res\ max}$$

where

- P_{max} = maximum equivalent load
- f_d = factor for load conditions
- $F_{res\ max}$ = maximum resulting load

Static safety factor

The static safety factor s_0 for linear guides is the relationship between the static load rating C_0 (↳ **chapter 2.1.1**) and the maximum vertical static bearing load P_0 or the maximum equivalent load P_{max} . For all applications, the safety factor should always be equal or above 2. The recommended safety factor per operating condition is defined in **table 12**. For all linear guide selections, the calculation of the static safety factor has to be done according the formula below.

$$(11) \quad s_0 = \frac{C_0}{P_0} = \frac{C_0}{P_{max}} = \frac{C_0}{f_d \cdot F_{res\ max}}$$

where

- s_0 = static safety factor
- C_0 = basic static load rating
- P_0 = maximum vertical static load
- P_{max} = maximum equivalent load
- $F_{res\ max}$ = maximum resulting load
- f_d = factor for load conditions

Fig. 7

Static load direction

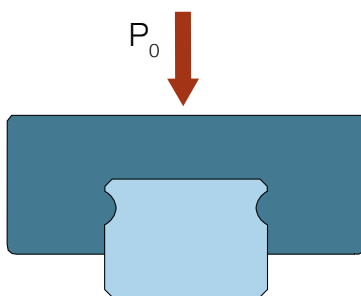

Table 12

Static safety factor recommendations

Operating conditions	s_0
Smooth operating conditions	≥ 2
Light vibrations or impact loads	2-4
Medium vibrations or impact loads	3-5
High vibrations or impact loads	> 5

IMPORTANT: Please always take into account the general technical rules and standards in the respective industry. If an application poses a risk of serious injury, the user must take appropriate design and safety measures that will prevent the linear guide from being detached or loosen from the structure.

2.2.6 Linear guide calculator

Ewellix linear guide calculator is a free online calculation tool. It is a self-explanatory e-tool to support all linear guide users perform a complete rating life and static bearing load calculation. The content of chapter 2 with all definitions, decisions and calculations has been transformed into this e-tool.

With that support it is much easier to determine what size of linear guide must be used for the given application. This online app makes product selection extremely efficient and supports the user in the design process.

The flow is like it is described in this catalogue:

1. Input of the motion cycles
2. Input of dynamic values of motion
3. Input of moved masses and operating loads
4. Input of drive forces
5. Decide on dimensional boundaries
6. Decide on preload class

When the input screens are completed, the user receives a clearly structured overview with results from which the final product can be selected as well as producing a report in pdf format. The detailed report contains:

- Summary input data
- Detailed dimensional drawings
- Load results per load phase
- List of factors of influence
- Modified basic rating life
- Results for static safety factor

And these calculations can be saved and reloaded for modification later on.

Follow the QR-code shown below to see this highly sophisticated online tool, free of charge at www.ewellix.com.



3

Product range

3.1 Carriage data

LLSHC ... TA
Standard carriage, shielded



Size	Load ratings	
	C	C ₀
-	N	
7	915	1460
9	1700	2800
12	2500	3900
15	3900	5850

LLSHC ... TA R
Standard carriage, sealed



Size	Load ratings	
	C	C ₀
-	N	
7	915	1460
9	1700	2800
12	2500	3900
15	3900	5850

LLSHC ... LA
Standard carriage extended length, shielded



Size	Load ratings	
	C	C ₀
-	N	
7	1270	2400
9	2280	4300
12	3550	6300
15	5500	9800

LLSHC ... LA R
Standard carriage extended length, sealed



Size	Load ratings	
	C	C ₀
-	N	
7	1270	2400
9	2280	4300
12	3550	6300
15	5500	9800

LLSWC ... TA
Wide carriage, shielded



Size	Load ratings	
	C	C ₀
-	N	
7	1220	2200
9	2160	4050
12	3100	5300
15	5000	8500

LLSWC ... TA R
Wide carriage, sealed



Size	Load ratings	
	C	C ₀
-	N	
7	1220	2200
9	2160	4050
12	3100	5300
15	5000	8500

LLSWC ... LA
Wide carriage extended length, shielded



Size	Load ratings	
	C	C ₀
-	N	
7	1660	3450
9	2850	5850
12	4250	8300
15	6550	12500

LLSWC ... LA R
Wide carriage extended length, sealed



Size	Load ratings	
	C	C ₀
-	N	
7	1660	3450
9	2850	5850
12	4250	8300
15	6550	12500

3

3.1.1 Standard carriage

LLSHC .. TA

- **Shielded** version with only rolling friction
- Available from size 7 to 15
- Available as system or separate as Zero Rail Concept type
- Made from stainless steel for corrosion protection
- Highest safety, with robust metal plate ball retention



LLSHC .. TA R

- **Sealed** version with very low friction seal
- Available from size 7 to 15
- Available as system or separate as Zero Rail Concept type
- Made from stainless steel for corrosion protection
- Highest safety, with robust metal plate ball retention



Range overview ¹⁾

Series	Range	Type	Size	Carriage length	Shielded or Sealed	Preload class	Rail length ²⁾	Precision class	Parallel mounted rails	Zero Rail Concept
LLS	H	C, R, S	7, 9, 12, 15	TA	No code, R	T0, T1, T2	mm	P5, P1	No code ,W2,Wx	ZRC
Zero Rail concept series	Standard rail width	Carriage	7	Standard	No code, R	T0, T1	–	P5	–	ZRC
			9	Standard	No code, R	T0, T1	–	P5	–	ZRC
			12	Standard	No code, R	T0, T1	–	P5	–	ZRC
			15	Standard	No code, R	T0, T1	–	P5	–	ZRC
	Rail	7	–	–	–	max. 1 000	P5	–	ZRC	
		9	–	–	–	max. 2 000	P5	–	ZRC	
		12	–	–	–	max. 2 000	P5	–	ZRC	
		15	–	–	–	max. 2 000	P5	–	ZRC	
System series	Standard rail width	System	7	Standard	No code, R	T0, T1, T2	max. 1 000	P5, P1	No code ,W2,Wx	–
			9	Standard	No code, R	T0, T1, T2	max. 2 000	P5, P1	No code ,W2,Wx	–
			12	Standard	No code, R	T0, T1, T2	max. 2 000	P5, P1	No code ,W2,Wx	–
			15	Standard	No code, R	T0, T1, T2	max. 2 000	P5, P1	No code ,W2,Wx	–

¹⁾ For detailed information about the complete ordering key and explanations, please have a look at **chapter 5**.

²⁾ Rails manufactured as cut to length might not be able to be delivered to the full length due to the E dimension.

Ordering and designation example:

Carriage: LLSHC 12 TA T0 P5 ZRC
 Rail: LLSHR 12-550 P5 E0 ZRC
 System : LLSHS9TA2T0-260P1/E0

Dimensional drawing

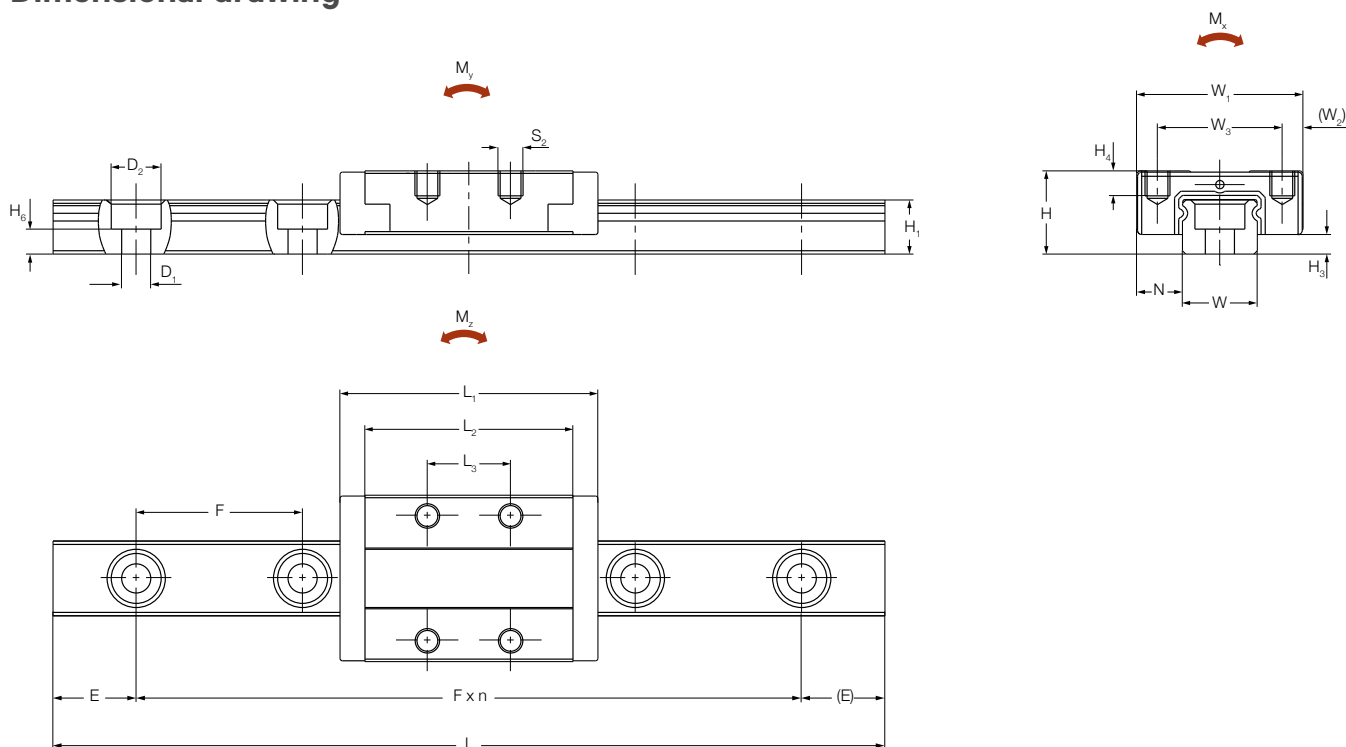

Technical data

Size	Assembly dimensions			Rail dimensions									
	W_1	H	N	H_3	W	H_1	H_6	F	D_1	D_2	$E_{min}^{1)}$	$E_{max}^{1)}$	$L_{max}^{2)}$
-	mm												
7	17	8	5	1,5	7	4,8	2,3	15	2,5	4,5	4	11	1000
9	20	10	5,5	2,35	9	6,5	3	20	3,5	6	5	15	2000
12	27	13	7,5	3,35	12	8,8	4,3	25	3,5	6	5	20	2000
15	32	16	8,5	4	15	9,5	5	40	3,5	6	5	35	2000

Size	Carriage dimensions							Weight		Load ratings ³⁾		Moments ³⁾			
	L_1	L_2	L_3	W_2	W_3	S_2	H_4	carriage	rail	dynamic	static	dynamic	static	dynamic	static
-	mm							kg	kg/m	N					
7	23,5	18	8	2,5	12	M2	2,5	0,012	0,230	915	1460	3	4,6	1,7	2,6
9	31	25	10	2,5	15	M3	3	0,021	0,395	1700	2800	7,1	11,5	4,6	7,5
12	35	29	15	3,5	20	M3	3,5	0,041	0,745	2500	3900	14	21,5	7,5	11,7
15	44	37	20	3,5	25	M3	4	0,080	1,035	3900	5850	23,6	38,9	14,3	23,9

¹⁾ Tolerance of E dimension is $\pm 0,5$ mm. One of the E dimension will be produced within the given tolerance. The second (E) dimension is for reference only. Pls contact your Ewellix representative in case the tolerance of the (E) dimensions is relevant for your application.

²⁾ Rails manufactured as cut to length might not be able to be delivered to the full length due to the E dimension. Tolerance for rail cut to length is $\pm 1,5$ mm while the tolerance for standard rail length is on request.

³⁾ Dynamic load capacities and moments are based on a travel life of 100 km. Please refer to **chapter 2** for further details.

3.1.2 Standard carriage extended length

LLSHC .. LA

- Standard **long** carriage with higher performance
- **Shielded** version with only rolling friction
- Available from size 7 to 15
- Available as system or separate as Zero Rail Concept type
- Made from stainless steel for corrosion protection
- Highest safety, with robust metal plate ball retention



LLSHC .. LA R

- Standard **long** carriage with higher performance
- **Sealed** version with very low friction seal
- Available from size 7 to 15
- Available as system or separate as Zero Rail Concept type
- Made from stainless steel for corrosion protection
- Highest safety, with robust metal plate ball retention



Range overview ¹⁾

Series	Range	Type	Size	Carriage length	Shielded or Sealed	Preload class	Rail length ²⁾	Precision class	Parallel mounted rails	Zero Rail Concept
LLS	H	C, R, S	7, 9, 12, 15	LA	No code, R	T0, T1, T2	mm	P5, P1	No code, W2, Wx	ZRC
Zero Rail concept series	Standard rail width	Carriage	7	Extended	No code, R	T0, T1	–	P5	–	ZRC
			9	Extended	No code, R	T0, T1	–	P5	–	ZRC
			12	Extended	No code, R	T0, T1	–	P5	–	ZRC
			15	Extended	No code, R	T0, T1	–	P5	–	ZRC
		Rail	7	–	–	–	max. 1 000	P5	–	ZRC
			9	–	–	–	max. 2 000	P5	–	ZRC
			12	–	–	–	max. 2 000	P5	–	ZRC
			15	–	–	–	max. 2 000	P5	–	ZRC
System series	Standard rail width	System	7	Extended	No code, R	T0, T1, T2	max. 1 000	P5, P1	No code, W2, Wx	–
			9	Extended	No code, R	T0, T1, T2	max. 2 000	P5, P1	No code, W2, Wx	–
			12	Extended	No code, R	T0, T1, T2	max. 2 000	P5, P1	No code, W2, Wx	–
			15	Extended	No code, R	T0, T1, T2	max. 2 000	P5, P1	No code, W2, Wx	–

¹⁾ For detailed information about the complete ordering key and explanations, please have a look at **chapter 5**.

²⁾ Rails manufactured as cut to length might not be able to be delivered to the full length due to the E dimension.

Ordering and designation example:

Carriage: LLSHC 12 LAR T0 P5 ZRC

Rail: LLSHR 12-550 P5 E0 ZRC

System : LLSHS9LA2T0-260P1/E0

Dimensional drawing

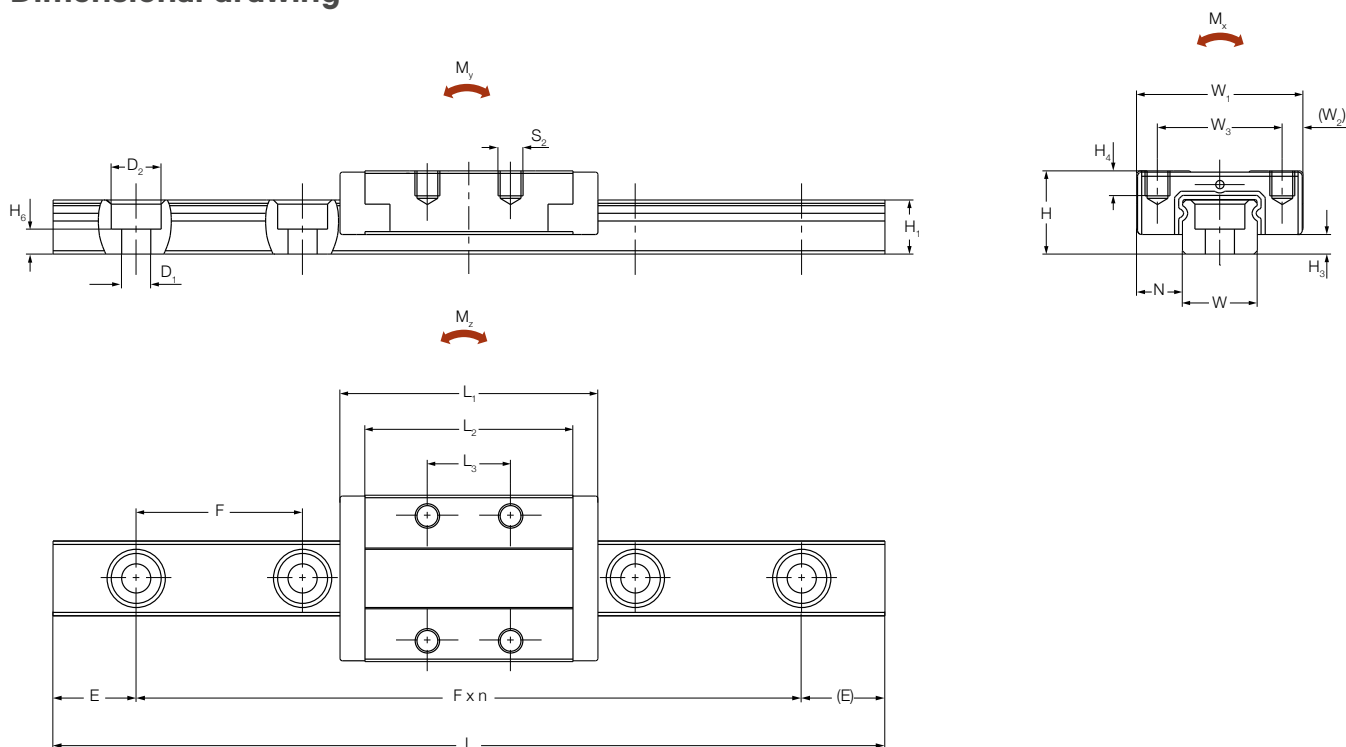

Technical data

Size	Assembly dimensions			Rail dimensions									
	W_1	H	N	H_3	W	H_1	H_6	F	D_1	D_2	$E_{min}^{1)}$	$E_{max}^{1)}$	$L_{max}^{2)}$
-	mm												
7	17	8	5	1,5	7	4,8	2,3	15	2,5	4,5	4	11	1000
9	20	10	5,5	2,35	9	6,5	3	20	3,5	6	5	15	2000
12	27	13	7,5	3,35	12	8,8	4,3	25	3,5	6	5	20	2000
15	32	16	8,5	4	15	9,5	5	40	3,5	6	5	35	2000

Size	Carriage dimensions							Weight		Load ratings ³⁾		Moments ³⁾				
	L_1	L_2	L_3	W_2	W_3	S_2	H_4	carriage	rail	dynamic	static	dynamic	static	dynamic	static	
-	mm							kg	kg/m	N						
7	31,5	26	13	2,5	12	M2	2,5	0,017	0,230	1270	2400	3,9	7,9	4,2	8,7	
9	40,5	34,5	16	2,5	15	M3	3	0,028	0,395	2280	4300	8,8	18,5	9,3	20,0	
12	46,5	40,5	20	3,5	20	M3	3,5	0,057	0,745	3550	6300	18,5	35,9	17,0	33,4	
15	62	55	25	3,5	25	M3	4	0,119	1,035	5500	9800	34,0	64,1	33,0	63,3	

¹⁾ Tolerance of E dimension is $\pm 0,5$ mm. One of the E dimension will be produced within the given tolerance. The second (E) dimension is for reference only. Pls contact your Ewellix representative in case the tolerance of the (E) dimensions is relevant for your application.

²⁾ Rails manufactured as cut to length might not be able to be delivered to the full length due to the E dimension. Tolerance for rail cut to length is $\pm 1,5$ mm while the tolerance for standard rail length is on request.

³⁾ Dynamic load capacities and moments are based on a travel life of 100 km. Please refer to **chapter 2** for further details.

3.1.3 Wide carriage

LLSWC .. TA

- **Wide** carriage for higher moment load
- **Shielded** version with only rolling friction
- Available from size 7 to 15
- Available as system or separate as Zero Rail Concept type
- Made from stainless steel for corrosion protection
- Highest safety, with robust metal plate ball retention



LLSWC .. TA R

- **Wide** carriage for higher moment load
- **Sealed** version with very low friction seal
- Available from size 7 to 15
- Available as system or separate as Zero Rail Concept type
- Made from stainless steel for corrosion protection
- Highest safety, with robust metal plate ball retention



Range overview ¹⁾

Series	Range	Type	Size	Carriage length	Shielded or Sealed	Preload class	Rail length ²⁾	Precision class	Parallel mounted rails	Zero Rail Concept
LLS	W	C, R, S	7, 9, 12, 15	TA	No code, R	T0, T1, T2	mm	P5, P1	No code, W2, Wx	ZRC
Zero Rail concept series	Wide rail width	Carriage	7	Standard	No code, R	T0, T1	-	P5	-	ZRC
			9	Standard	No code, R	T0, T1	-	P5	-	ZRC
			12	Standard	No code, R	T0, T1	-	P5	-	ZRC
			15	Standard	No code, R	T0, T1	-	P5	-	ZRC
		Rail	7	-	-	-	max. 2000	P5	-	ZRC
			9	-	-	-	max. 2000	P5	-	ZRC
			12	-	-	-	max. 2000	P5	-	ZRC
			15	-	-	-	max. 2000	P5	-	ZRC
System series	Wide rail width	System	7	Standard	No code, R	T0, T1, T2	max. 2000	P5, P1	No code, W2, Wx	-
			9	Standard	No code, R	T0, T1, T2	max. 2000	P5, P1	No code, W2, Wx	-
			12	Standard	No code, R	T0, T1, T2	max. 2000	P5, P1	No code, W2, Wx	-
			15	Standard	No code, R	T0, T1, T2	max. 2000	P5, P1	No code, W2, Wx	-

¹⁾ For detailed information about the complete ordering key and explanations, please have a look at **chapter 5**.

²⁾ Rails manufactured as cut to length might not be able to be delivered to the full length due to the E dimension.

Ordering and designation example:

Carriage: LLSWC 12 TAR T0 P5 ZRC

Rail: LLSWR 12-550 P5 E0 ZRC

System: LLSWS9TA2T0-260P1/E0

Dimensional drawing

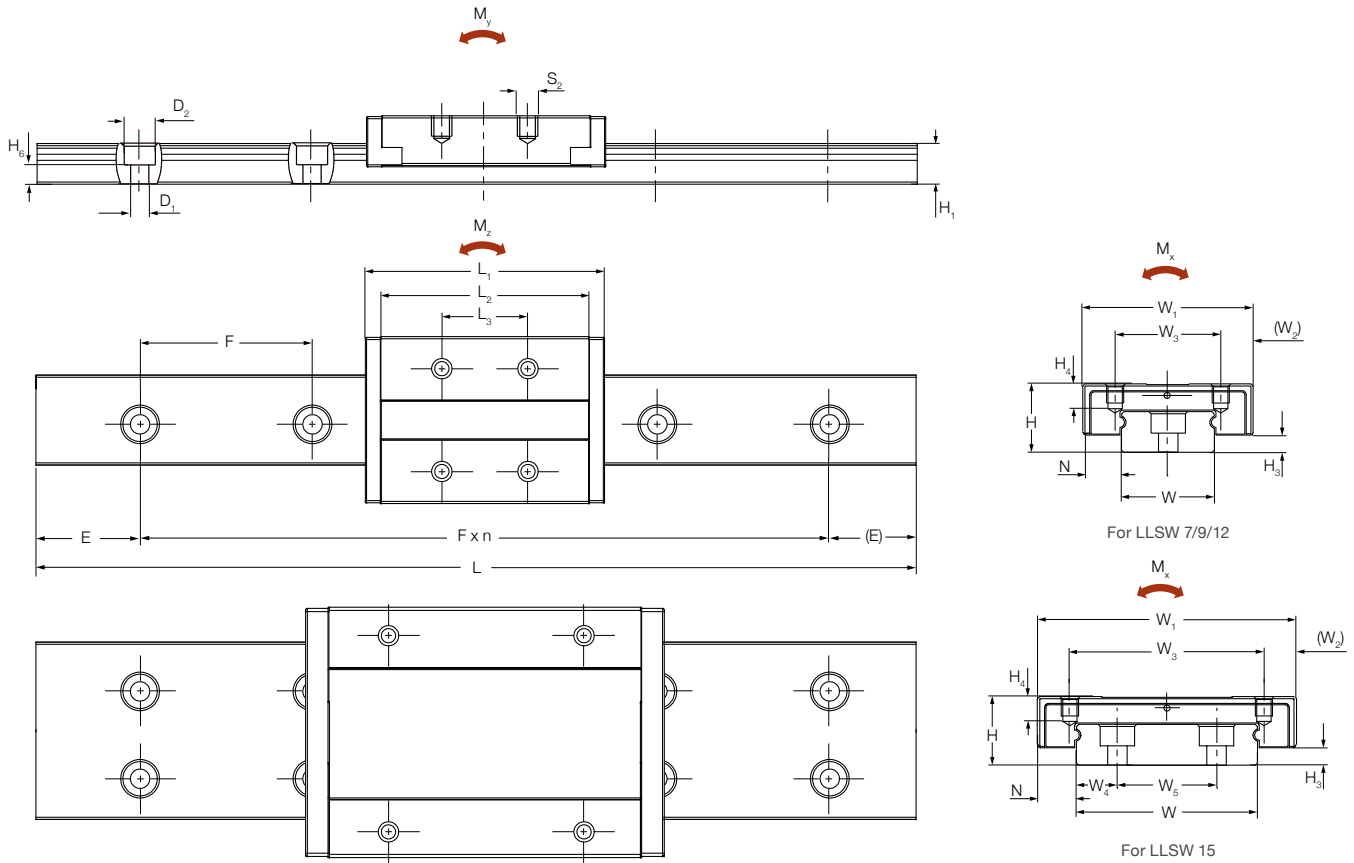

Technical data

Size	Assembly dimensions				Rail dimensions							$E_{min}^{1)}$	$E_{max}^{1)}$	$L_{max}^{2)}$	
	W_1	H	N	H_3	W	W_4	W_5	H_1	H_6	F	D_1				D_2
-	mm														
7	25	9	5,5	2	14	-	-	5,2	1,7	30	3,5	6	5	25	2000
9	30	12	6	2,5	18	-	-	7	2,5	30	3,5	6	5	25	2000
12	40	14	8	3	24	-	-	8,5	4	40	4,5	8	6	34	2000
15	60	16	9	4	42	9,5	23	9,5	5	40	4,5	8	6	34	2000

Size	Carriage dimensions							Weight		Load ratings ³⁾		Moments ³⁾			
	L_1	L_2	L_3	W_2	W_3	S_2	H_4	carriage	rail	dynamic	static	dynamic	static	dynamic	static
-	mm							kg	kg/m	N		Nm			
7	31	25,5	10	3	19	M3	3	0,024	0,540	1220	2200	8,2	14,7	3,6	6,4
9	39	33	12	4,5	21	M3	3	0,051	0,940	2160	4050	17,4	36,2	8,2	17,3
12	43,5	37,5	15	6	28	M3	3,5	0,085	1,525	3100	5300	36,0	69,1	14,7	28,5
15	55,5	48,5	20	7,5	45	M4	4,5	0,169	2,960	5000	8500	94	178,8	28,4	54,3

¹⁾ Tolerance of E dimension is $\pm 0,5$ mm. One of the E dimension will be produced within the given tolerance. The second (E) dimension is for reference only. Pls contact your Ewellix representative in case the tolerance of the (E) dimensions is relevant for your application.

²⁾ Rails manufactured as cut to length might not be able to be delivered to the full length due to the E dimension. Tolerance for rail cut to length is $\pm 1,5$ mm while the tolerance for standard rail length is on request.

³⁾ Dynamic load capacities and moments are based on a travel life of 100 km. Please refer to **chapter 2** for further details.



3.1.4 Wide carriage extended length

LLSWC .. LA

- **Wide long** carriage with higher performance
- **Shielded** version with only rolling friction
- Available from size 7 to 15
- Available as system or separate as Zero Rail Concept type
- Made from stainless steel for corrosion protection
- Highest safety, with robust metal plate ball retention



LLSWC .. LA R

- **Wide long** carriage with higher performance
- **Sealed** version with very low friction seal
- Available from size 7 to 15
- Available as system or separate as Zero Rail Concept type
- Made from stainless steel for corrosion protection
- Highest safety, with robust metal plate ball retention



Range overview ¹⁾

Series	Range	Type	Size	Carriage length	Shielded or Sealed	Preload class	Rail length ²⁾	Precision class	Parallel mounted rails	Zero Rail Concept
LLS	W	C, R, S	7, 9, 12, 15	LA	No code, R	T0, T1, T2	mm	P5, P1	No code, W2, Wx	ZRC
Zero Rail concept series	Wide rail width	Carriage	7	Extended	No code, R	T0, T1	–	P5	–	ZRC
			9	Extended	No code, R	T0, T1	–	P5	–	ZRC
			12	Extended	No code, R	T0, T1	–	P5	–	ZRC
			15	Extended	No code, R	T0, T1	–	P5	–	ZRC
	Rail	7	–	–	–	max. 2 000	P5	–	ZRC	
		9	–	–	–	max. 2 000	P5	–	ZRC	
		12	–	–	–	max. 2 000	P5	–	ZRC	
		15	–	–	–	max. 2 000	P5	–	ZRC	
System series	Wide rail width	System	7	Extended	No code, R	T0, T1, T2	max. 2 000	P5, P1	No code, W2, Wx	–
			9	Extended	No code, R	T0, T1, T2	max. 2 000	P5, P1	No code, W2, Wx	–
			12	Extended	No code, R	T0, T1, T2	max. 2 000	P5, P1	No code, W2, Wx	–
			15	Extended	No code, R	T0, T1, T2	max. 2 000	P5, P1	No code, W2, Wx	–

¹⁾ For detailed information about the complete ordering key and explanation, please have a look at **chapter 5**.

²⁾ Rails manufactured as cut to length might not be able to be delivered to the full length due to the E dimension.

Ordering and designation example:

Carriage: LLSWC 12 LAR T0 P5 ZRC
 Rail: LLSWR 12-550 P5 E0 ZRC
 System : LLSWS9LA2T0-260P1/E0

Dimensional drawing

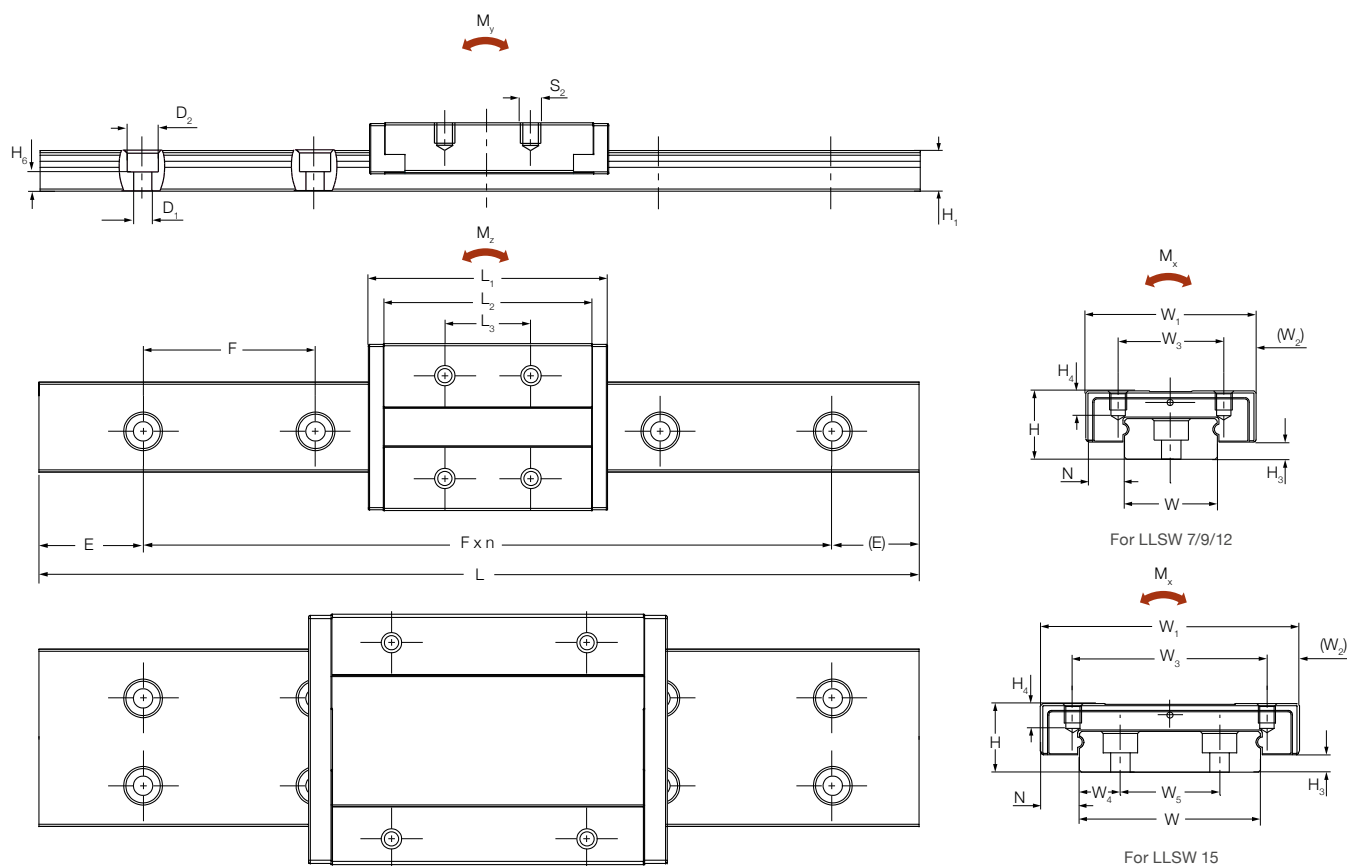

Technical data

Size	Assembly dimensions				Rail dimensions							E _{min} ¹⁾	E _{max} ¹⁾	L _{max} ²⁾		
	W ₁	H	N	H ₃	W	W ₄	W ₅	H ₁	H ₆	F	D ₁				D ₂	
-	mm															
7	25	9	5,5	2	14	-	-	5,2	1,7	30	3,5	6	5	25	2000	
9	30	12	6	2,5	18	-	-	7	2,5	30	3,5	6	5	25	2000	
12	40	14	8	3	24	-	-	8,5	4	40	4,5	8	6	34	2000	
15	60	16	9	4	42	9,5	23	9,5	5	40	4,5	8	6	34	2000	

Size	Carriage dimensions							Weight		Load ratings ³⁾		Moments ³⁾			
	L ₁	L ₂	L ₃	W ₂	W ₃	S ₂	H ₄	carriage	rail	dynamic	static	dynamic	static	dynamic	static
-	mm							kg	kg/m	N		Nm			
7	41,5	36	19	3	19	M3	3	0,034	0,540	1660	3450	11,2	23,0	7,6	15,8
9	50,5	44,5	24	3,5	23	M3	3	0,068	0,940	2850	5850	22,6	51,7	15,6	36,1
12	58	52	28	6	28	M3	3,5	0,118	1,525	4250	8300	45,3	96,8	26,9	57,9
15	74,5	67,5	35	7,5	45	M4	4,5	0,236	2,960	6550	12500	116,5	241,8	50,5	105,5

¹⁾ Tolerance of E dimension is ±0,5 mm. One of the E dimension will be produced within the given tolerance. The second (E) dimension is for reference only. Pls contact your Ewellix representative in case the tolerance of the (E) dimensions is relevant for your application.

²⁾ Rails manufactured as cut to length might not be able to be delivered to the full length due to the E dimension. Tolerance for rail cut to length is ±1,5 mm while the tolerance for standard rail length is on request.

³⁾ Dynamic load capacities and moments are based on a travel life of 100 km. Please refer to **chapter 2** for further details.



3.2 Rail data

3.2.1 Standard rails

LLSHR

- Standard rail width for standard carriages
- Available from size 7 to 15
- Available as system or separate as Zero Rail Concept type
- Made from stainless steel for corrosion protection
- With two reference sides for flexible mounting



Range overview ¹⁾

Series	Range	Type	Size	Rail length ²⁾	Precision class	Parallel mounted rails	Zero Rail Concept
LLS	H	C, R, S	7, 9, 12, 15	mm	P5, P1	No code, W2, Wx	ZRC
Zero Rail concept series	Standard rail width	Rail	7	max. 1 000	P5	–	ZRC
			9	max. 2 000	P5	–	ZRC
			12	max. 2 000	P5	–	ZRC
			15	max. 2 000	P5	–	ZRC
System series	Standard rail width	System	7	max. 1 000	P5, P1	No code, W2, Wx	–
			9	max. 2 000	P5, P1	No code, W2, Wx	–
			12	max. 2 000	P5, P1	No code, W2, Wx	–
			15	max. 2 000	P5, P1	No code, W2, Wx	–

¹⁾ For detailed information about the complete ordering key and explanation, please have a look at **chapter 5**.

²⁾ Rails manufactured as cut to length might not be able to be delivered to the full length due to the E dimension.

Ordering and designation example:

Rail 1: LLSHR 12-550 P5 D E0 ZRC

Rail 2: LLSHR 12-1050 P5 E0 ZRC

Dimensional drawing

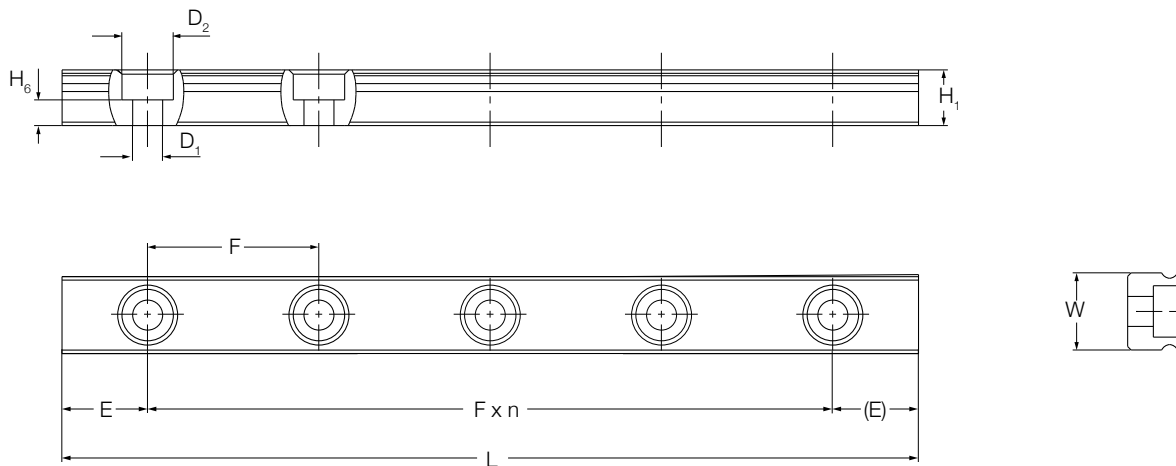
Technical data ¹⁾

Size	Rail dimensions									Weight rail kg/m
	W mm	H ₁	H ₆	F	D ₁	D ₂	E _{min} ²⁾	E _{max} ²⁾	L _{max} ³⁾	
7	7	4,8	2,3	15	2,5	4,5	4	11	1 000	0,230
9	9	6,5	3	20	3,5	6	5	15	2 000	0,395
12	12	8,8	4,3	25	3,5	6	5	20	2 000	0,745
15	15	9,5	5	40	3,5	6	5	35	2 000	1,035

¹⁾ Suitable mounting screws and recommended tightening torques are listed in **chapter 4.1.3**.

²⁾ Tolerance of E dimension is $\pm 0,5$ mm. One of the E dimension will be produced within the given tolerance. The second (E) dimension is for reference only. Pls contact your Ewellix representative in case the tolerance of the (E) dimensions is relevant for your application.

³⁾ Rails manufactured as cut to length might not be able to be delivered to the full length due to the E dimension. Tolerance for rail cut to length is $\pm 1,5$ mm while the tolerance for standard rail length is on request.

3.2.2 Wide rails

LLSWR ..

- Wide rail width for wide carriages
- Available from size 7 to 15
- Available as system or separate as Zero Rail Concept type
- Made from stainless steel for corrosion protection
- With two reference sides for flexible mounting



Range overview ¹⁾

Series	Range	Type	Size	Rail length ²⁾	Precision class	Parallel mounted rails	Zero Rail Concept
LLS	W	C, R, S	7, 9, 12, 15	mm	P5, P1	No code, W2, Wx	ZRC
Zero Rail concept series	Wide rail width	Rail	7	max. 2000	P5	–	ZRC
			9	max. 2000	P5	–	ZRC
			12	max. 2000	P5	–	ZRC
			15	max. 2000	P5	–	ZRC
System series	Wide rail width	System	7	max. 2000	P5, P1	No code, W2, Wx	–
			9	max. 2000	P5, P1	No code, W2, Wx	–
			12	max. 2000	P5, P1	No code, W2, Wx	–
			15	max. 2000	P5, P1	No code, W2, Wx	–

¹⁾ For detailed information about the complete ordering key and explanation, please have a look at **chapter 5**.

²⁾ Rails manufactured as cut to length might not be able to be delivered to the full length due to the E dimension.

Ordering and designation example:

Rail 1: LLSWR 12-550 P5 D E0 ZRC

Rail 2: LLSWR 12-1050 P5 E0 ZRC

Dimensional drawing

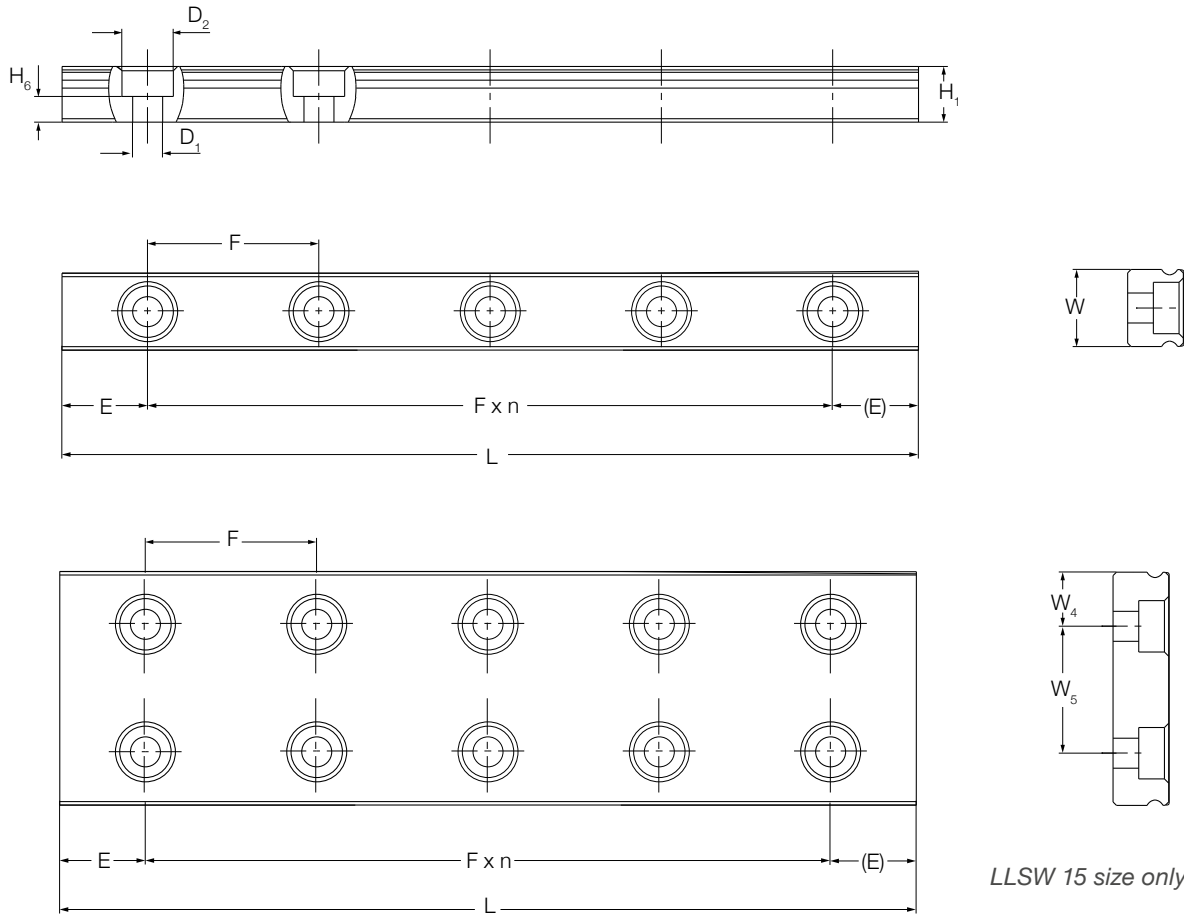

3

Technical data ¹⁾

Size	Rail dimensions											Weight rail kg/m
	W mm	W_4	W_5	H_1	H_6	F	D_1	D_2	$E_{min}^{2)}$	$E_{max}^{2)}$	$L_{max}^{3)}$	
7	14	-	-	5,2	1,7	30	3,5	6	5	25	2 000	0,540
9	18	-	-	7	2,5	30	3,5	6	5	25	2 000	0,940
12	24	-	-	8,5	4	40	4,5	8	6	34	2 000	1,525
15	42	9,5	23	9,5	5	40	4,5	8	6	34	2 000	2,960

¹⁾ Suitable mounting screws and recommended tightening torques are listed in **chapter 4.1.3**.

²⁾ Tolerance of E dimension is $\pm 0,5$ mm. One of the E dimension will be produced within the given tolerance. The second (E) dimension is for reference only. Pls contact your Ewellix representative in case the tolerance of the (E) dimensions is relevant for your application.

³⁾ Rails manufactured as cut to length might not be able to be delivered to the full length due to the E dimension. Tolerance for rail cut to length is $\pm 1,5$ mm while the tolerance for standard rail length is on request.

3.2.3 Number of holes and E-dimension

The "E" dimension is the distance from the rail end to centre of the first attachment hole. If no specific "E" dimension is requested, the rails are produced with similar "E" dimensions at both ends. The Number of rail attachment holes z and the "E" dimensions can be calculated as follows:

$$z = 1 + \text{TRUNC} \left(\frac{L - 2 \cdot E_{\min}}{F} \right)$$

$$E = \left(\frac{L - F(z-1)}{2} \right)$$

- z = Number of attachment holes in rail
- F = Distance of attachment holes
- L = Rail length
- E_{min} = Minimum E-dimension according to catalogue
- E = E-dimension

NOTE: "TRUNC" is the mathematical function that truncates a number to an integer by removing the fractional part of the number.

Dimension scheme on rails

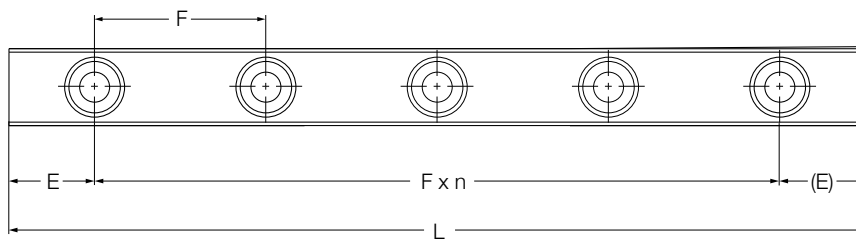

Range	Size	F	E _{min} ¹⁾	E _{max} ¹⁾	L _{max} ²⁾
		mm			
Standard type rail	7	15	4	11	1 000
	9	20	5	15	2 000
	12	25	5	20	2 000
	15	40	5	35	2 000
Wide type rail	7	30	5	25	2 000
	9	30	5	25	2 000
	12	40	6	34	2 000
	15	40	6	34	2 000

¹⁾ Tolerance of E dimension is ±0,5 mm. One of the E dimension will be produced within the given tolerance. The second (E) dimension is for reference only. Pls contact your Ewellix representative in case the tolerance of the (E) dimensions is relevant for your application.

²⁾ Rails manufactured as cut to length might not be able to be delivered to the full length due to the E dimension. Tolerance for rail cut to length is ±1,5 mm while the tolerance for standard rail length is on request.

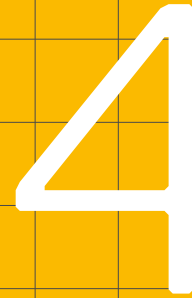

4



Mounting and maintenance

4.1 Design rules

4.1.1 Use of profile rails

To maintain the high precision of Ewellix LLS profile rail guides, the carriages and rails must be handled carefully during transport and mounting.

To provide protection during transport, storage and assembly, LLS rails and carriages are coated with a corrosion inhibiting compound. For details about the compound please see **table 1** below.

The corrosion protection does not need to be removed before using. For optimized running performance, Ewellix recommends removal of the anti-rust oil at the rails.

Tab. 1

Produce type	Compound type
System	Standard lubricant
ZRC range carriages	Standard lubricant
ZRC range cutted rails	Standard lubricant
ZRC range rails in 1 or 2 m length	Anti-rust oil

4.1.2 Typical mounting

Rails

Each rail has ground reference surfaces on both sides.

Options for securing the rails laterally (↳ fig. 1)

1. Stop edges
2. Retaining strips

Rails that are not lateral fixed must be installed straight and parallel (↳ fig. 2). Ewellix recommends using retaining strips to maintain the position of the rails during installation.

Carriage

Each carriage has ground reference surfaces on both sides.

Options for securing the carriages lateral (↳ fig. 1)

3. Stop edges
4. Retaining strips

NOTE: If mounted correctly, the carriage should move easily on the rail when pushed.

Fig. 1

Mounting with lateral fixed rails and carriages

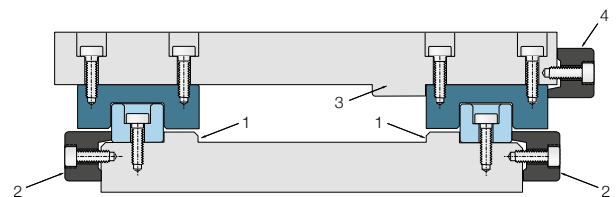
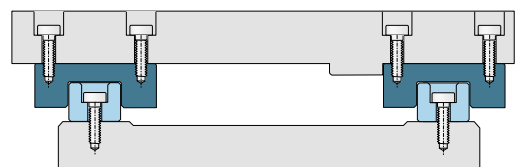

Fig. 2

Mounting without lateral rail support



4.1.3 Interface design and bolt torque

Figure 3 shows the ideal mounting arrangement for LLS miniature profile rail guides. Carriages and rails can be mounted at both sides as they do have a reference surface on both sides. Ewellix recommends that you have the stop edges of the carriage and rail on the same side of the linear guide system.

To ensure the right tolerances to enable a perfect fit to the surrounding design, specific at the edges, Ewellix suggests you follow the detailed dimensions recommended in table 3.

Tightening torque for bolts

Table 2 shows the maximum tightening torques for fixing bolts depending on the thread size.

Fig. 3

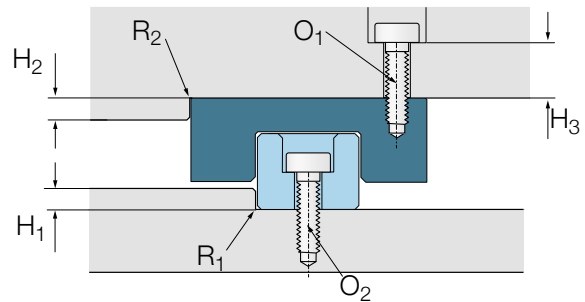

Table 2

Tightening torque of fixing bolts	
Thread size	Maximum tightening torque Ncm
M2	32
M3	110
M4	260

Table 3

Size	Dimensions			H ₂	R ₂ max	H ₃	Screw	
	H ₁ min	H ₁ max	R ₁ max				O ₁	O ₂
-	mm							
7	1,1	1,3	0,3	2,2	0,2	2,8	M2 × 5	M2 × 5
9	1,3	1,6	0,3	2,5	0,2	5,3	M3 × 8	M3 × 8
12	2	2,6	0,4	3,5	0,2	6,8	M3 × 10	M3 × 10
15	3	3,6	0,4	4,5	0,4	6,8	M3 × 10	M3 × 10
7 wide	1,1	1,7	0,3	2,2	0,2	2,8	M3 × 5	M3 × 5
9 wide	1,3	1,9	0,3	2,5	0,2	5,3	M3 × 8	M3 × 8
12 wide	2	2,6	0,4	3,5	0,2	6,8	M3 × 10	M4 × 10
15 wide	3	3,6	0,4	4,5	0,4	6,0	M4 × 10	M4 × 12



4.1.4 Maximum height deviation

The values for height deviation in lateral and longitudinal direction are applicable for all carriage types.

If the values for height deviation S_1 (↪ **table 4**) and S_2 (↪ **table 5**) are within the specified range, the service life of the rail guide system will not be influenced.

Maximum lateral height deviation

The maximum height deviation in lateral direction S_1 on parallel rail installations is related to preload class and rail distance d (↪ **table 4**).

It can be calculated with the lateral factor Y for preload class and should never exceed the height tolerances described in **table 3** at **chapter 2.1.3**. Precision classes.

$$S_1 = d \cdot Y \text{ and } S_1 < 2 \cdot H \text{ or } S_1 < \Delta H$$

where

- S_1 = Maximum lateral height deviation [mm]
- d = Distance between parallel rails [mm]
- Y = Calculation factor for lateral direction
- H = System height tolerance per precision class [mm]
- ΔH = Height deviation on parallel mounted rails [mm]

If the lateral height deviation S_1 exceeds 2 times of H or ΔH , a different preload class or precision class should be used. Another possibility is to order the miniature profile rails as parallel mounted rails "W2" in the ordering key to fulfill the requirements. When S_1 is still higher, then Ewellix recommends another design layout.

Maximum longitudinal height deviation

The maximum height deviation in longitudinal direction S_2 on profile rail systems with more than one carriage on the same rail is related to the carriage type and distance c (↪ **table 5**).

It can be calculated with the longitudinal factor X for the different carriage types and should never exceed the height deviation ΔH described in **table 3** at **chapter 2.1.3**. Precision classes.

$$S_2 = c \cdot X \text{ and } S_2 < \Delta H$$

where

- S_2 = Maximum lateral height deviation [mm]
- c = Distance between carriages [mm]
- X = Calculation factor for longitudinal direction
- ΔH = Height deviation of multiple carriages on same rail [mm]

If the longitudinal height deviation S_2 is exceeding ΔH , a different carriage type or precision class should be used. When S_2 is still higher, then Ewellix recommends another design layout.

Table 4

Height deviation in lateral direction

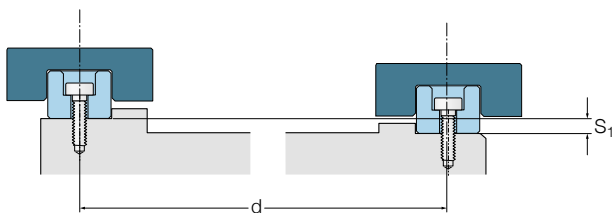

Lateral factor	Preload class		
	T0	T1	T2
Y	$3,0 \times 10^{-4}$	$1,5 \times 10^{-4}$	$1,0 \times 10^{-4}$

Table 5

Height deviation in longitudinal direction

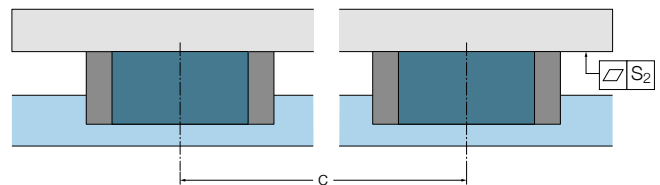

Longitudinal factor	Carriage length	
	TA standard	LA extended
X	7×10^{-5}	7×10^{-5}

4.1.5 Parallelism of guide systems

The parallelism of mounted rails is measured on the rails and the carriages. The values for the deviation in parallelism S_3 are applicable to all carriage and rail types.

Deviations in parallelism S_3 increase the internal load. If the values are within the specified range in **table 4**, the service life of the profile rail guide system will not be influenced.

For typical applications, the mounting surface can be slightly resilient.

However, for very high-precision applications, the mounting surface must be rigid and the values in the table have to be cut in half.

Table 6

Maximum deviation in parallelism S_3

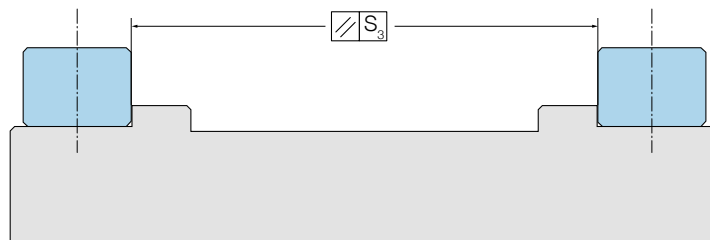

Size	Range	Preload class		
		T0 µm	T1 µm	T2 µm
-				
7	standard / wide	5	2	1
9	standard / wide	6	3	2
12	standard / wide	7	4	2
15	standard / wide	10	7	4



4.1.6 Tolerance of rail mounting holes

For suitable designs of mounting threads or holes, please find below the tolerance of distances between the mounting holes of miniature profile rails .

For standard and wide rails with center mounting holes, please see **figure 4** and for wide size 15 with two mounting hole rows, please see **figure 5**.

Fig. 4

Standard and wide rails with center mounting holes

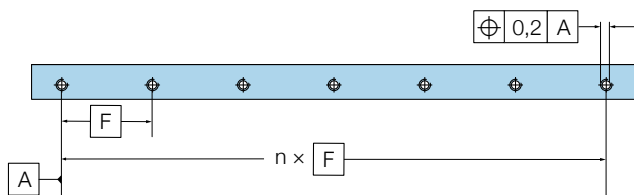
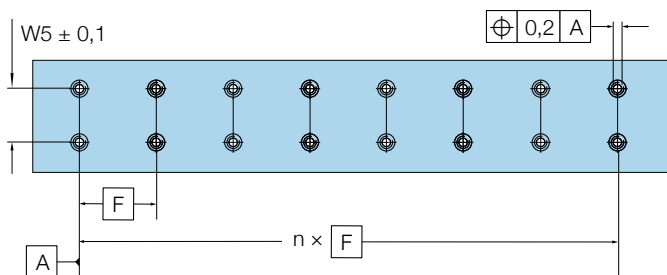

Fig. 5

15 wide rails with two mounting hole rows



4.2 Mounting profile rail guides

4.2.1 Packaging (Shipment)

For the systems, the carriages have been mounted on the rail, and the system will be wrapped in a plastic foil. For the ZRC carriages and ZRC rails, the rails and carriages are delivered in their own packaging. Unwrap these components carefully.



4.2.2 Mounting the ZRC carriages

Be sure the ends of the rail are deburred to avoid damaging the front seals or internal components. As both sides of the rail and carriage are the reference surfaces, the carriage can be mounted in both directions. The LLS carriages contain an innovative ball retention, so the carriage can be mounted without a mounting sleeve. Slide the carriage straight and carefully onto the rail, avoiding any misalignment (→ see beside QR-code).



[Video: LLS - Miniature profile rail mounting](#)

4.2.3 Preparation

The threaded holes on the base plate must be first prepared according to the rail size. Make sure that the contact surfaces are flat and free of any damage or burrs. Use an oil stone to smooth them if necessary (→ fig 6). Check the stop edges for dimensional and position precision and inspect the corner radii (→ 4.1.3, table 3). Clean the contact surfaces thoroughly. Coat them with a thin coat of light oil to prevent corrosion. Make sure that the rails, carriages, base plate, mounting plate and fastening screws all have the same temperature during installation.

Remove the corrosion inhibiting compound from the rail or carriage surfaces that are in contact with other parts. Then apply a thin coat of light oil to these surfaces. Be sure that all drilled and tapped holes are clean and free of debris prior to mounting.

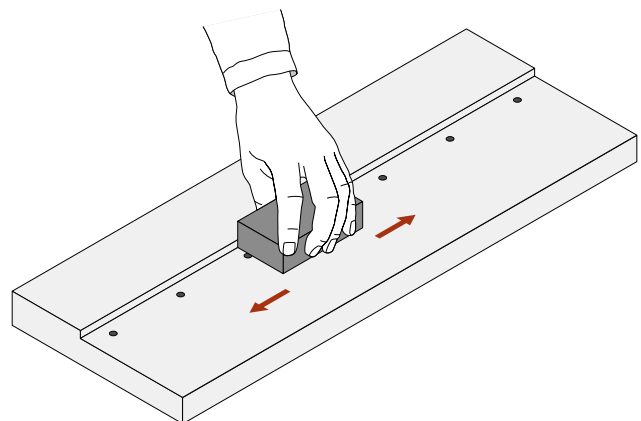

Fig. 6



4.2.4 Mounting the rail

1. Place the rail gently onto the base plate.
2. Insert the screws, making sure that they are unobstructed, e.g. the mounting holes are properly aligned.
3. Partially tighten the bolts. Push the rail against the stop edge (↳ **fig. 7**). The stop edge can be directly machined in the mounting surface or an external/mobile support strip that is only there for mounting. If necessary, hold the rail in place with a retaining strip (↳ **4.1.2, fig 1**). In cases where no lateral support is provided, use an external reference surface (↳ **fig. 8**) or a straight edge for alignment.
4. Using a torque wrench, tighten the centre mounting screw. Then, tighten the remaining screws using an alternating pattern (↳ **fig. 9**). Torque values are listed in **4.1.3, table 2**.
5. Check the parallelism of the fastened rail to the specific reference. Result should be better than values in **4.1.5, table 6**.

4.2.5 Parallel alignment of rail

The already aligned and fastened rail is defined as the master rail. Depending on the base plate design, there are several options for mounting subsidiary rails. Please choose the suitable option listed below.

Mounting option I

Mounting with two stop edges on the base plate. If stop edges are provided on both sides of the base plate (↳ **fig 10**), please proceed as described above in **4.2.4, Mounting the rail**.

Fig. 7

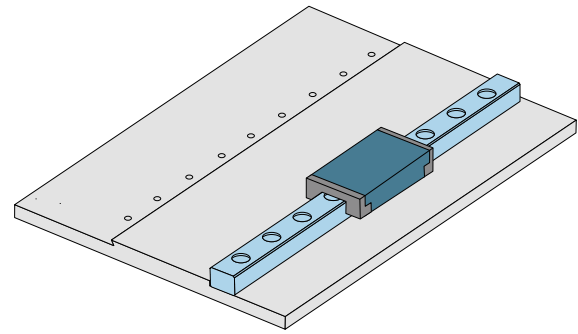

Fig. 8

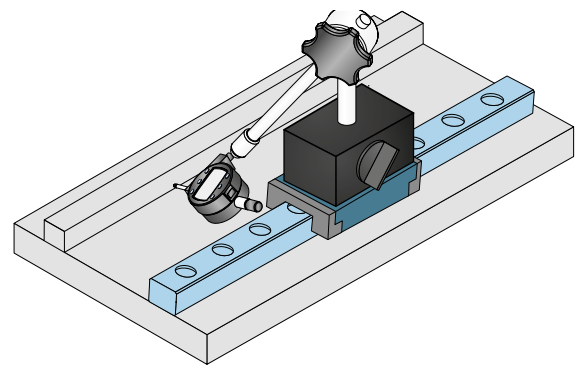

Fig. 9

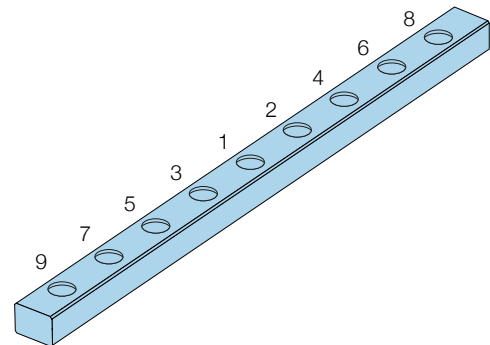
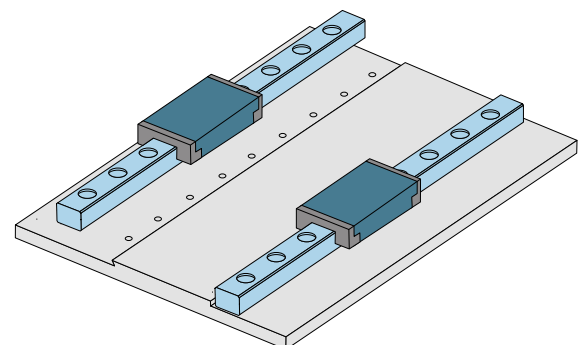

Fig. 10



Mounting option II

Mounting with two stop edges on the top carriage's mounting plate. If there is no stop edge for the subsidiary rail on the base plate, the second rail can be aligned using a carriage's mounting plate with two stop edges.

1. Push in the carriage against the stop edge of the mounting plate (↳ **fig. 11**).
2. Using a torque wrench, tighten the mounting screws to the designated value (↳ **4.1.3 table 2**).
3. Place the subsidiary rail onto the base plate.
4. Insert the screws, making sure that they are unobstructed, e.g. the mounting holes are properly aligned. (↳ **fig. 12**).
5. Partially tighten the screws so that the subsidiary rail is still loose.
6. Slide the mounting plate with the already fastened carriages onto the rails and move it over the full stroke (↳ **fig. 13**).
7. Starting at one end of the subsidiary rail, pre-tighten the rail screws to approximately 1/3 of their torque value. To maintain parallelism, be sure that the carriage is very close to the screws being tightened. (↳ **fig. 14**). Double-check for parallelism by running the carriages along their full stroke. Then, using a torque wrench, tighten the centre mounting screw. Tighten the remaining screws using the alternating pattern (↳ **fig. 9**). Torque values are listed in **4.1.3 table 2**.

NOTE: The resulting parallelism has to be the values in **chapter 4.1.5 at table 6**.

Fig. 11

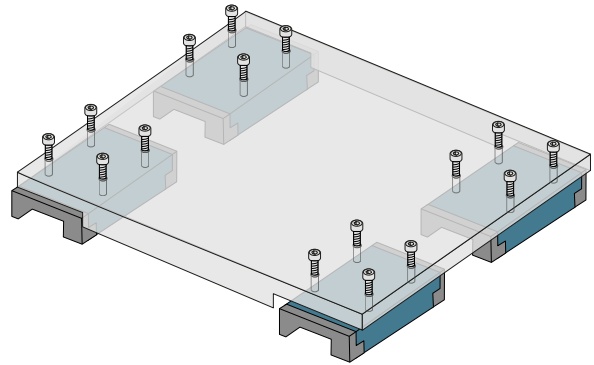

Fig. 12

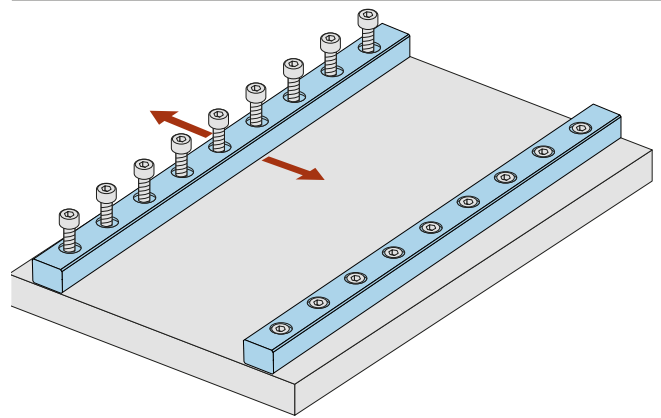

Fig. 13

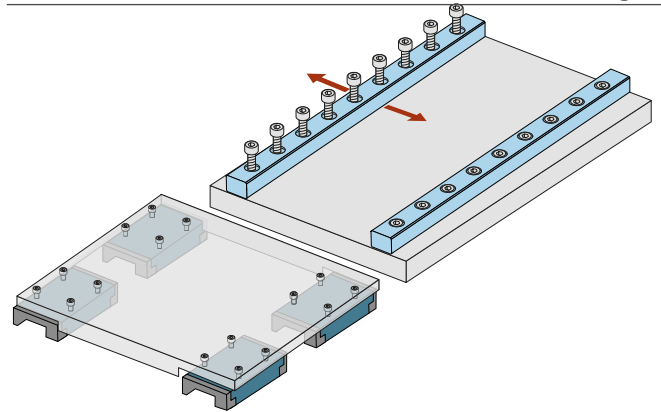
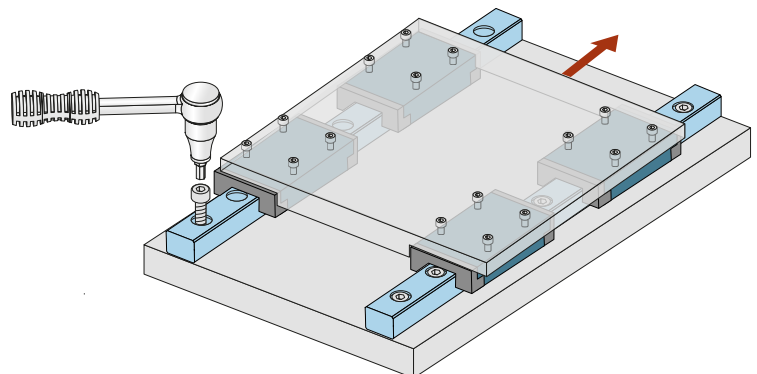

Fig. 14



Mounting option III

Mounting with no stop edges

If there are no stop edges for the subsidiary rail on the base plate and no stop edges for the carriages on the mounting plate, then proceed as follows:

1. Place the subsidiary rail onto the base plate.
2. Insert the screws, making sure that they are unobstructed, e.g. the mounting holes are properly aligned (↳ **fig. 15**).
3. Partially tighten the screws so that the rail is still loose.
4. Slide a carriage onto the mounted master rail and affix a dial indicator to the top of the carriage. Place the tip of the indicator at the center of the ground reference edge of the subsidiary rail (↳ **fig. 16**).
5. Do the alignment and pre-fasten the screws with 1/3 torque (↳ **fig. 17**).
6. Tighten all rail screws, beginning from the center, alternating to the ends (↳ **fig. 9**), with designated torque (↳ **4.1.3, table 3**) by using a torque wrench.
7. Double check the parallelism along the full stroke.

NOTE : The resulting parallelism has to be the values in **chapter 4.1.5 at table 6**.

Fig. 15

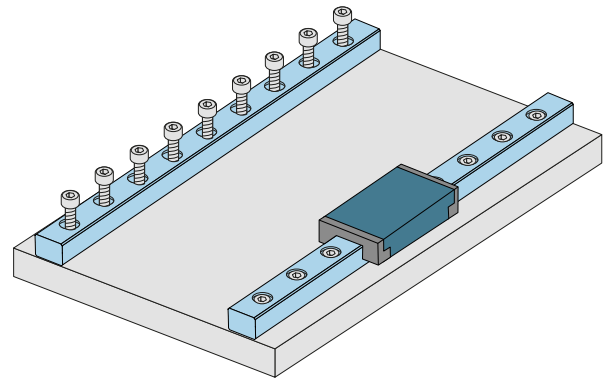

Fig. 16

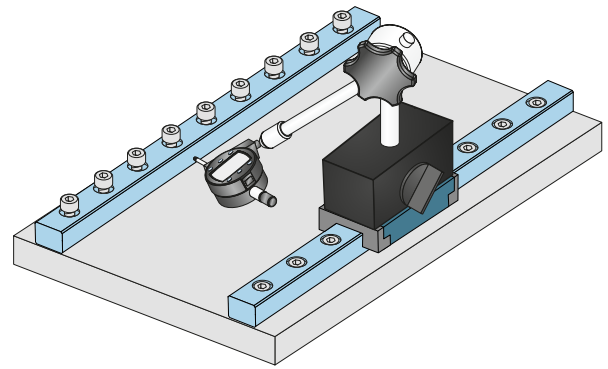
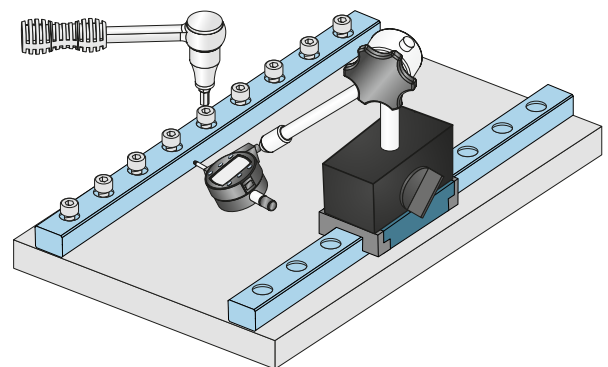

Fig. 17



4.3 Maintenance and repairs

4.3.1 Lubrication and maintenance

Ewellix miniature profile rail guides are factory pre lubricated and are ready for operation upon delivery.

They are lubricated with an NSF H1 registered oil complying with FDA 21 CFR § 178.3570. This oil is based on medical pure oil in accordance with European pharmacopeia (medical white oil). This oil was developed for incidental contact with products and packaging materials in the food-processing, cosmetics, pharmaceutical or animal feed industries.

The individual carriages can be relubricated via the front lubrication hole (→ fig. 18). Please contact Ewellix sales if you need relubrication sets.

The relubrication intervals depend on the travel paths, cycles and ambient conditions.

4.3.2 Factory pre lubrication

LLS carriages are normally supplied pre lubricated with NSF H1 registered oil. The technical data for this grease can be found in table 7.

4.3.3 Correct relubrication

The lubricant must be topped up via both relubrication holes into the carriage. During lubrication, the carriage must be moved several times so that the lubricant is completely circulated.

The amount of relubrication depends on the applied conditions.

Table 8 provides guidelines on the amount of lubricant for relubrication for one carriage. The total amount should be split equally in the two lubrication holes if possible.

Fig. 18

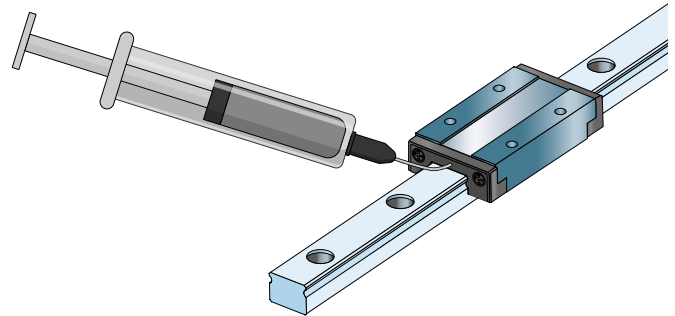

Table 7

Klüber PARALIQ P 460

Properties	Specification
Base oil	Paraffin mineral oil
Minimum operating temperature	-20 °C
Maximum operating temperature	100 °C
ISO Viscosity grade, DIN ISO 3448	460

Table 8

Type	Amount of lubricant mm ³
-	
LLSHC 7 TA/LA	50
LLSHC 9 TA/LA	70
LLSHC 12 TA/LA	90
LLSHC 15 TA/LA	150
LLSWC 7 TA/LA	60
LLSWC 9 TA/LA	90
LLSWC 12 TA/LA	140
LLSWC 15 TA/LA	200

4.3.4 Relubrication interval

Re-greasing intervals are very much dependent on the application conditions, including load, speed, stroke and the environment, such as temperature, dust, etc.

Generally, re-greasing is recommended after 1 000 km of service or after 1 year of installation.

In lower demanding applications, it is recommended to relubricate either after 5 000 km of service or after 3 years of installation, whichever comes first.



4.4 Storage environment recommendations

LLS linear guide carriages and rails should be stored in the original package. Unpacking should be avoided until installation. Additionally, miniature profile rail guides should be stored where they are not exposed to contaminants, vibrations, shocks, humidity or other detrimental conditions. The storage environment recommendations are set forth in the table below.

Table 9

Item	Condition
Environment temperature	5 to 25 °C, and the temperature shall not change drastically
Relative humidity	< 60%

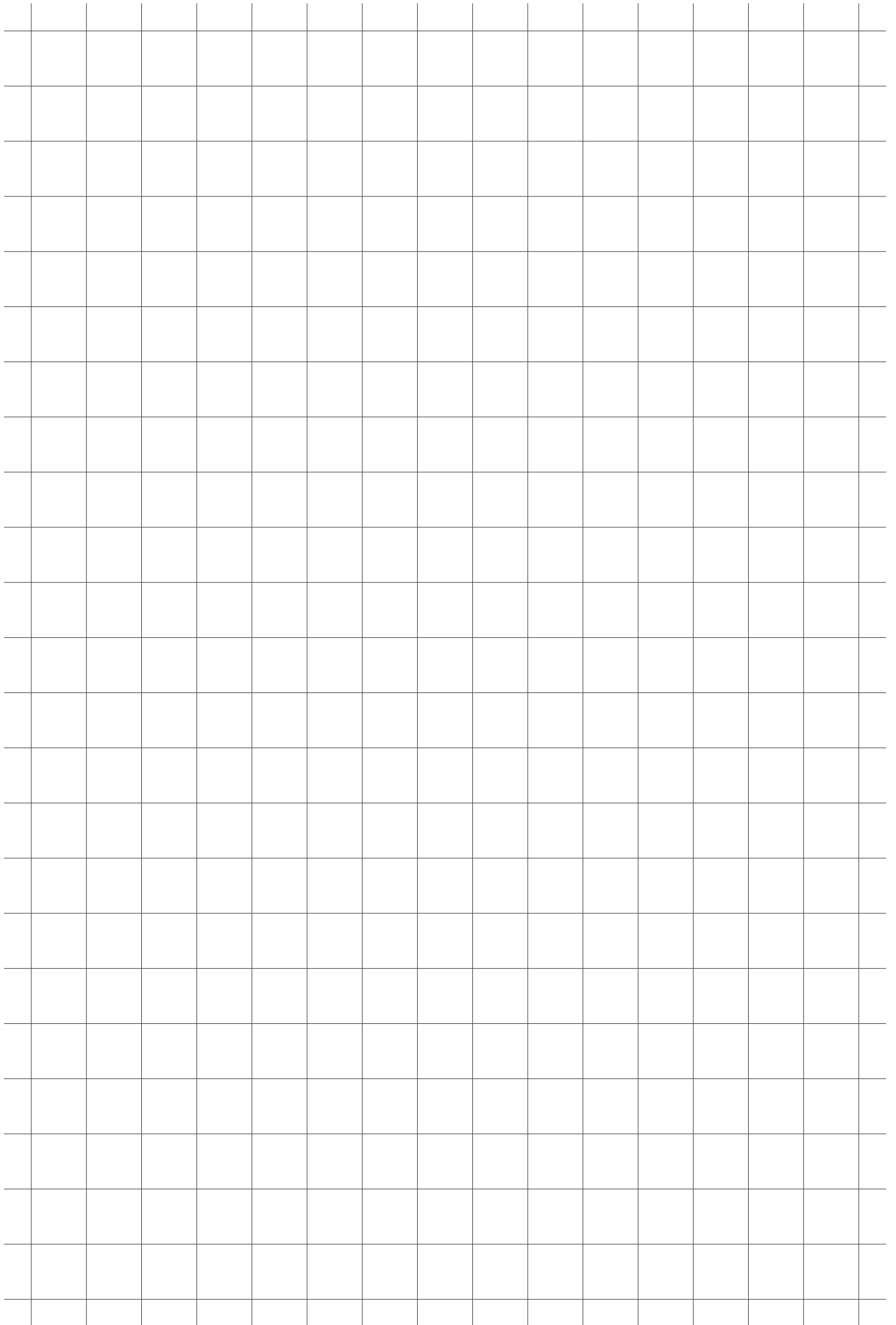

5

Ordering key

Ordering key systems

LLS H S 12 TA R 2 T0 - 500 P5 / W2 E10

LLS Miniature profile rail guide series

Range code

- H Standard range
- W Wide range

Type code

- S System, mounted carriage on rail

Size

- 7, 9, 12, 15

Carriage type

- TA Standard or Wide carriage, standard length
- LA Standard or Wide carriage, extended length

Seal options

- no code Shielded carriage
- R Low friction sealed carriage

Number of carriages per rail

- 1, 2, 3, 4, 6

Preload Class

- T0 Light clearance
- T1 Light preload
- T2 Medium preload

Rail Length

Up to 2 000 mm length in 1 mm steps, exception LLSH 7 with up to 1 000 mm length

Precision Class

- P5 Standard precision
- P1 High precision

Rail arrangement (Number of parallel mounted rails)

- no code Arrangement of single rail as standard
- W2 Arrangement of two parallel mounted rails
- Wx Arrangement of x number of parallel mounted rails

Rail type

- no code Standard rail
- D Customized rail

Distance between end face and the center of the first mounting hole of the rail

- E0 Standard "E" dimension, even when not selected. The holes at both rails end will be positioned equidistantly from either end of the rails with shortest possible distance
- Exx Specified "E" dimension for one rail end with the dimension range per size as described in **chapter 3.2**



Ordering key ZRC carriages

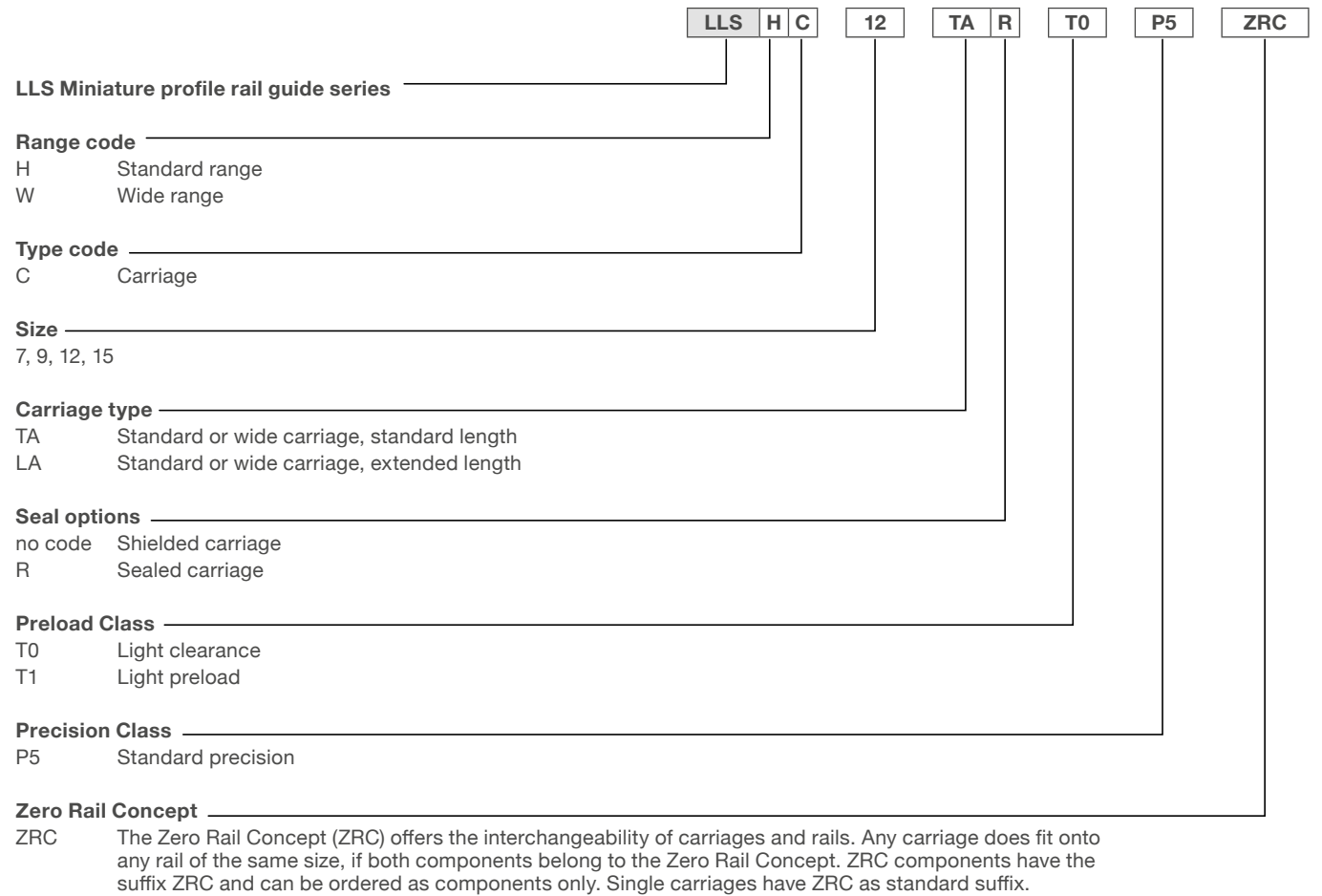

Ordering key ZRC rails

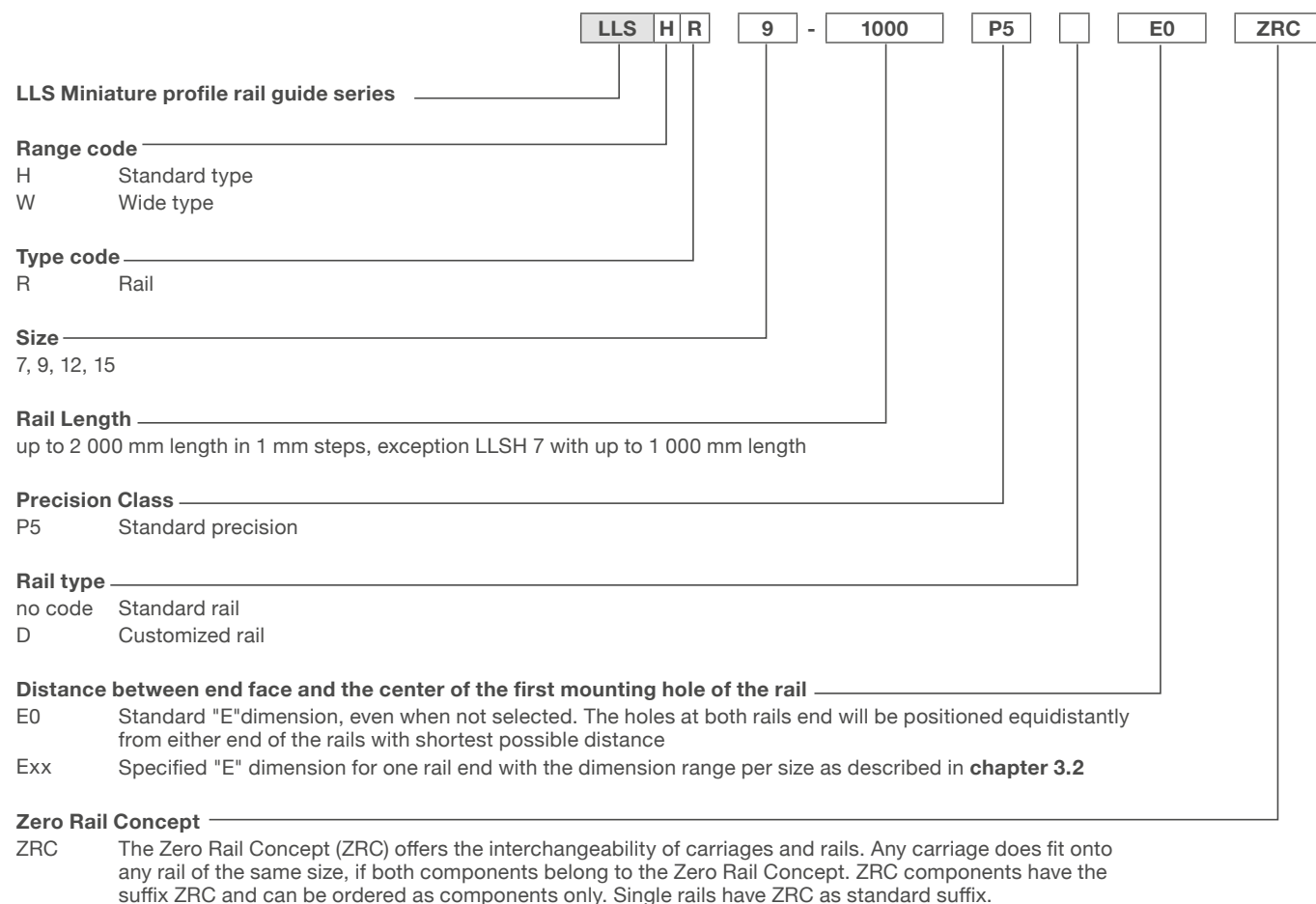

6

Customer specification sheet

Specification sheet – Profile rail guide LLS

Please complete the form with all available information and send it to your Ewellix representative or authorized distributor for product selection.

<i>Ewellix contact</i>	<i>Date</i>
------------------------	-------------

General information

Customer	Contact					
<i>Company</i>	<i>Contact name</i>					
<i>Address 1</i>	<i>Job title</i>					
<i>Address 2</i>	<i>Department</i>					
<table border="1" style="width: 100%; border-collapse: collapse;"> <tr> <td style="width: 33%; padding: 5px;"><i>Post code / Zip</i></td> <td style="width: 33%; padding: 5px;"><i>City</i></td> <td style="width: 33%; padding: 5px;"><i>State</i></td> </tr> </table>	<i>Post code / Zip</i>	<i>City</i>	<i>State</i>	<table border="1" style="width: 100%; border-collapse: collapse;"> <tr> <td style="width: 50%; padding: 5px;"><i>Phone (including country code)</i></td> <td style="width: 50%; padding: 5px;"><i>Mobile (including country code)</i></td> </tr> </table>	<i>Phone (including country code)</i>	<i>Mobile (including country code)</i>
<i>Post code / Zip</i>	<i>City</i>	<i>State</i>				
<i>Phone (including country code)</i>	<i>Mobile (including country code)</i>					
<i>Country</i>	<i>Mail</i>					
<i>Project title</i>						

Reason for request

<i>Current product / brand</i>		<i>Description</i>
<input type="radio"/> Replacement	<input type="radio"/> New design	<input type="radio"/> Other

Application / Industry

<input type="radio"/> Factory automation	<input type="radio"/> Food and beverage	<input type="radio"/> Machine tools	<input type="radio"/> Other
<input type="radio"/> Medical	<input type="radio"/> Semiconductor	<i>Description</i>	

Export control and Ewellix policy (mandatory to mark)

<input type="radio"/> The application is not subsidiary or part of industry of national defence and/or nuclear (also not with details of the function).The application is civil.
--

Commercial information

General

<input type="radio"/> One shot business <input type="radio"/> Yearly repeating business	<i>Quantity, pcs</i>	<i>Batch size, pcs</i>	<i>Start of supply, YYYY MM DD</i>	<i>Target price / each</i> <i>Currency</i>
--	----------------------	------------------------	------------------------------------	--

Application description



Stroke	Rail length	Center distance between	or Short part dimensions	Guiding system
mm	mm	carriages, c mm rails, d mm	Length mm Width mm	Maximum height mm <input type="checkbox"/> No constraints

Required service life distance or time (fill in all fields)

Required static safety (in accordance to your business and application)

Distance km	Total time h	Period of one cycle s	Stroke of one cycle mm
-------------	--------------	-----------------------	------------------------

Maximum speed ¹⁾

Maximum acceleration ¹⁾

Rigidity of guiding system

Running accuracy of guiding system

m/s

m/s²

N/ μ m
 No specific requirements

Parallelism in height	μ m
Parallelism in sideward direction	μ m

¹⁾ Here the maximum values. Enter load phase specific values in table "External loads and load phases"

Environment

<p><i>Presence of dust, dirt or fluids</i></p> <input type="checkbox"/> Clean environment, e.g. laboratory <input type="checkbox"/> Standard industrial environment <input type="checkbox"/> Dirty environment, e.g. milling machine	<p><i>Requirements on friction</i></p> <input type="checkbox"/> Lowest possible friction <input type="checkbox"/> Standard friction <input type="checkbox"/> No requirement	<p><i>Preferred sealing version</i></p> <input type="checkbox"/> Shielded version (no code) <input type="checkbox"/> Low friction sealed version (R)
<input type="checkbox"/> Humid or corrosive environment If yes, please describe:	<p><i>Preferred material</i></p> <input type="checkbox"/> No preference (standard)	

Temperature [°C]

Minimum	Operating	Maximum
---------	-----------	---------

Shock loads or vibrations
 If yes, please describe:

Lubricant

Standard prelubrication by Ewellix, as stated in the catalogue
 Other Please specify:

Sketch of the application (or attach a drawing)

Product details

Product designation (if already known)

Carriage type



Preload class

<input type="radio"/> T0 (Light clearance)	<input type="radio"/> T1 (Light preload 2% C)	<input type="radio"/> T2 (Medium preload 8% C)
--	---	--

Precision class

<input type="radio"/> P5 (Standard precision)	<input type="radio"/> P1 (High precision)	
---	---	--

Input for dimensioning calculation

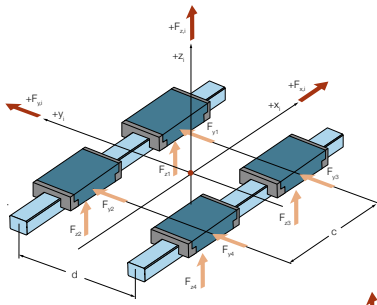

o Config 24

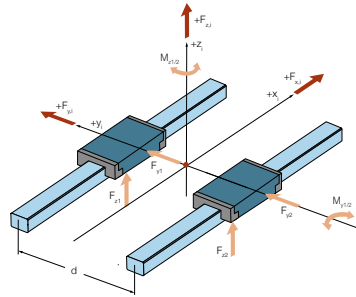

o Config 22

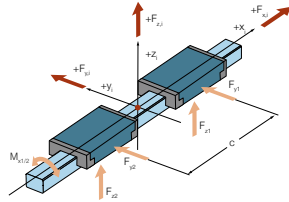

o Config 12

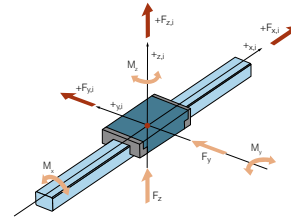

o Config 22

- No preference
- Other

If yes, please describe:

Moving direction (set coordinate system accordingly)

- Horizontal
- Vertical
- Other

Please specify:

External loads and load phases

Forces in N, lever arms in mm measured from defined origin (see graphics above). If the application has more than 3 load phases, please copy this page.

Load phase 1				
Stroke	mm			
Acceleration	mm/s ²			
Speed	m/s			
	Lever arms in			
Force F _x	x	y	z	
Force F _y	x	y	z	
Force F _z	x	y	z	

Load phase 2				
Stroke	mm			
Acceleration	mm/s ²			
Speed	m/s			
	Lever arms in			
Force F _x	x	y	z	
Force F _y	x	y	z	
Force F _z	x	y	z	

Load phase 3				
Stroke	mm			
Acceleration	mm/s ²			
Speed	m/s			
	Lever arms in			
Force F _x	x	y	z	
Force F _y	x	y	z	
Force F _z	x	y	z	



ewellix.com

© Ewellix

All contents of this publication are the property of Ewellix, and may not be reproduced or given to third parties (even extracts) without permission. Although great care has been taken in the production of this catalog, Ewellix does not take any responsibility for damage or other loss resulting from omissions or typographical errors. The photo may differ slightly in appearance from the actual product. Due to continuous improvements being made in our products, the product's appearance and specifications are subject to change without notice.

PUB NUM IL-06021/2-EN-February 2023

Schaeffler and Schaeffler logo are trademarks of the Schaeffler Group.