



HepcoMotion®

DLS
Driven Linear System

BISHOPWISECARVER®

CONTENTS

Page

HepcoMotion® DLS3 and 4	1
System Composition	2-4
Application Examples	5-7
Data & Dimensions	8-12
Standard Axis	8
AC Geared Motors & Gearboxes	9
Drive Options	10
Cantilever Axis	11
Ancillary Mechanical Parts	12
Choosing the Right System	13-16
System Accuracy & Repeatability	17
Application Recommendations	17
Technical Section	18-21
Slide Load, Life & Deflection	18-19
Linear Drive Calculations	20-21
Ordering Details DLS3 and 4	22-23
HepcoMotion® DLS5	24-25

HepcoMotion® DLS3 and 4 Linear Transmission

To satisfy increasing customer requirements, Hepco has upgraded its popular DLS range of linear transmissions.

A new range of cost effective, high quality **AC geared motors and worm gearboxes** has been added to create a complete linear drive solution which is ideally suited to many positioning applications. Motors up to 1.1kW are offered as are gearboxes with ratios from 5:1 to 75:1. This provides driving forces to 1225N and linear speeds from zero to 2m/s (up to 5+m/s for systems using special motors). The reduced engineering package gives the power, flexibility and reliability of an electrical positioning drive at a price which is competitive with lesser pneumatic systems.

The AC motor drive allows the unit to be driven in end-to-end applications without further controls, or the unit can be linked together with a customer's PLC to provide more complex point-to-point control. Customers requiring more sophisticated function and control may specify gearboxes engineered into the drive of the DLS which can link with servo or stepper motor systems and controls. Using this method, the DLS can address even the most demanding and dynamic multi-axis positioning requirements.

Customers wishing to make their own arrangements for the drive may purchase any DLS with a drive shaft.

In addition to the 2 sizes of standard axes, we have added a **new cantilever axis**. This is ideally suited to applications where the carriage is stationary and the beam is the moving part, as the motor and cables remain stationary.

The cantilever axis will be the best selection in many single axis duties as well as being the preferred choice for the Y or Z axis in many multi-axis machines.





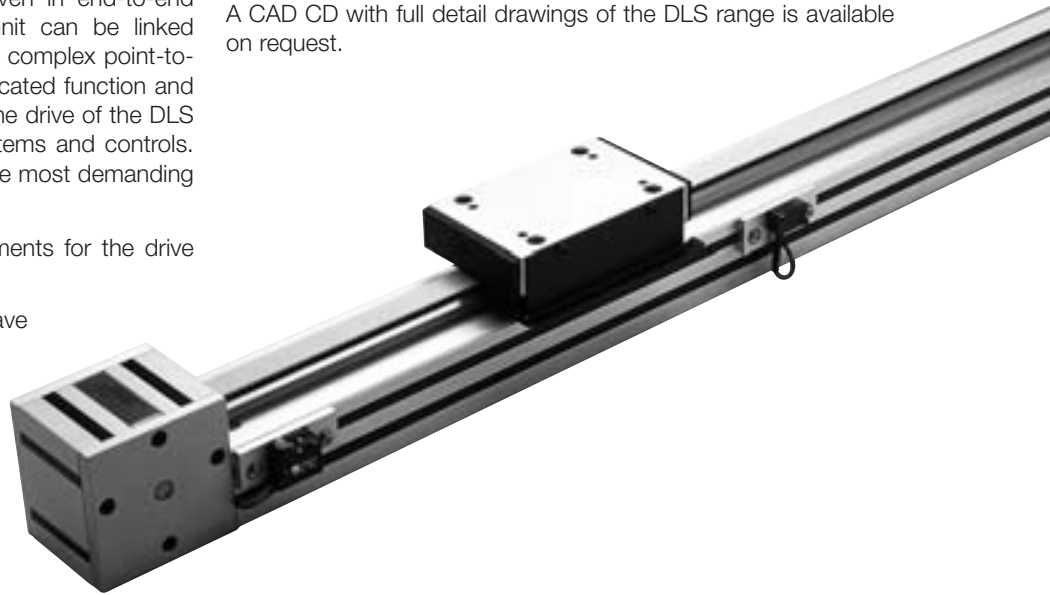

Bishop-Wisecarver will provide the necessary mechanical and electrical components to complete a full-function unit, including switches, mounting clamps, shafts, couplings, gearboxes, motors, drives, brakes and torque limiters. Bishop-Wisecarver is always happy to help customers with their applications, and meeting your specific requirement is our aim, even if the solution is not contained in this catalog.

The DLS range is compatible with aluminum machine construction systems from HepcoMotion®-MCS and other major manufacturers. Please complete and submit an Application Data Sheet on the Bishop-Wisecarver website.

A CAD CD with full detail drawings of the DLS range is available on request.



Drive Options as Simple or Sophisticated as You Need

	With Input / Output Shaft	_____	For chain, belt or shaft drive or to connect two axes in parallel (page 7)
	With Fitted AC Geared Motor	_____	The cost-effective solution for simple positioning applications (pages 9 & 13-17)
	Allen-Bradley Speed Controller	_____	Economical means to control speed, acceleration and simple positioning functions (pages 4, 15 & 16)
	With Fitted Worm Gearbox	_____	Compact right angle gearbox tailored to suit your own motor (page 9)
	With Precision Planetary Gearbox	_____	Tailored to suit your own motor. Ideally suited to servo applications (page 10)
	With Special Flange	_____	Compact connection inside unit to suit your own motor gearbox (page 10)

System Composition

Standard Axis

The HepcoMotion® DLS provides the complete solution to linear drive problems. It has been engineered with all the options required to enable it to handle almost any linear positioning application. The illustration below shows a unit with a fitted AC geared brake motor, which also has the optional output shaft (to enable direct coupling to a second unit, see page 7). It is fitted with a microswitch mounted using a switch bracket, and this switch is operated by the switch cam which is shown attached to the carriage. The DLS unit can be attached to a mounting base using a fixing clamp (illustrated).

A key feature of the DLS is the carriage, which is made from two separate aluminum plates. The top plate can be removed by releasing the 4 or 5 socket head screws which allows further machining to the customer's requirements. The DLS is provided with convenient T slots along the length and in the end boxes. These T slots allow the customer to position T nuts in exactly the right position to suit the application.

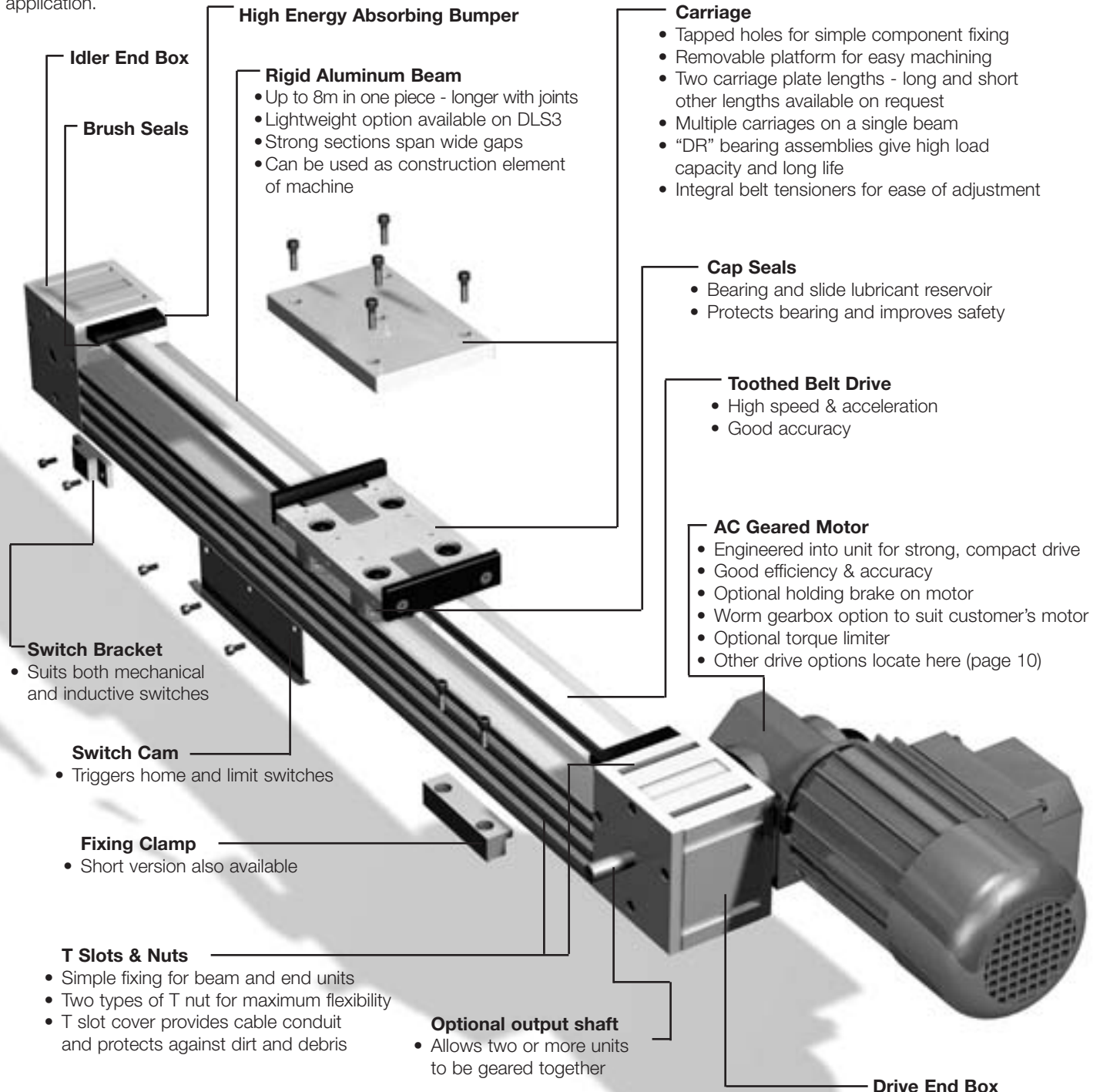

Note: The unit shown has AC geared motor mounted in position 1 (see page 8) with terminal box in position C (cable entry in position 1, not visible).

Cantilever Axis

The cantilever axis is particularly useful in Z-axis or horizontal pick and place applications. It is intended to be used with the beam moving on the carriage, as opposed to the standard DLS where the beam is stationary. It is available in size 3 only.

Supplied with the lightweight beam as standard, this arrangement offers rigid support for cantilever loads with the minimum of inertia. It is particularly useful in the context of a multi-axis system (see application examples on pages 6 & 7) where the DLS3C is mounted onto the carriage of a standard DLS axis.

The DLS3C can be offered with carriage and beam lengths to suit customer requirements (see page 11). Units may be supplied with the same fitted AC geared motor as is used on the standard DLS. The worm gearbox may be specified without a motor for coupling to the customer's own drive, or a high precision, high efficiency gearbox (shown below) can be specified. These planetary units are directly coupled to the drive pulley for best accuracy, are available with ratios from 4:1 to 20:1 and are ideally suited for use with servo motors. Bishop-Wisecarver can supply a pre-drilled flange for gearboxes to suit a customer's motor. Like the standard axis, the 3 plates of the carriage, and the component mounting plate on the end of the beam are easily removed to allow machining to the customer's requirements.

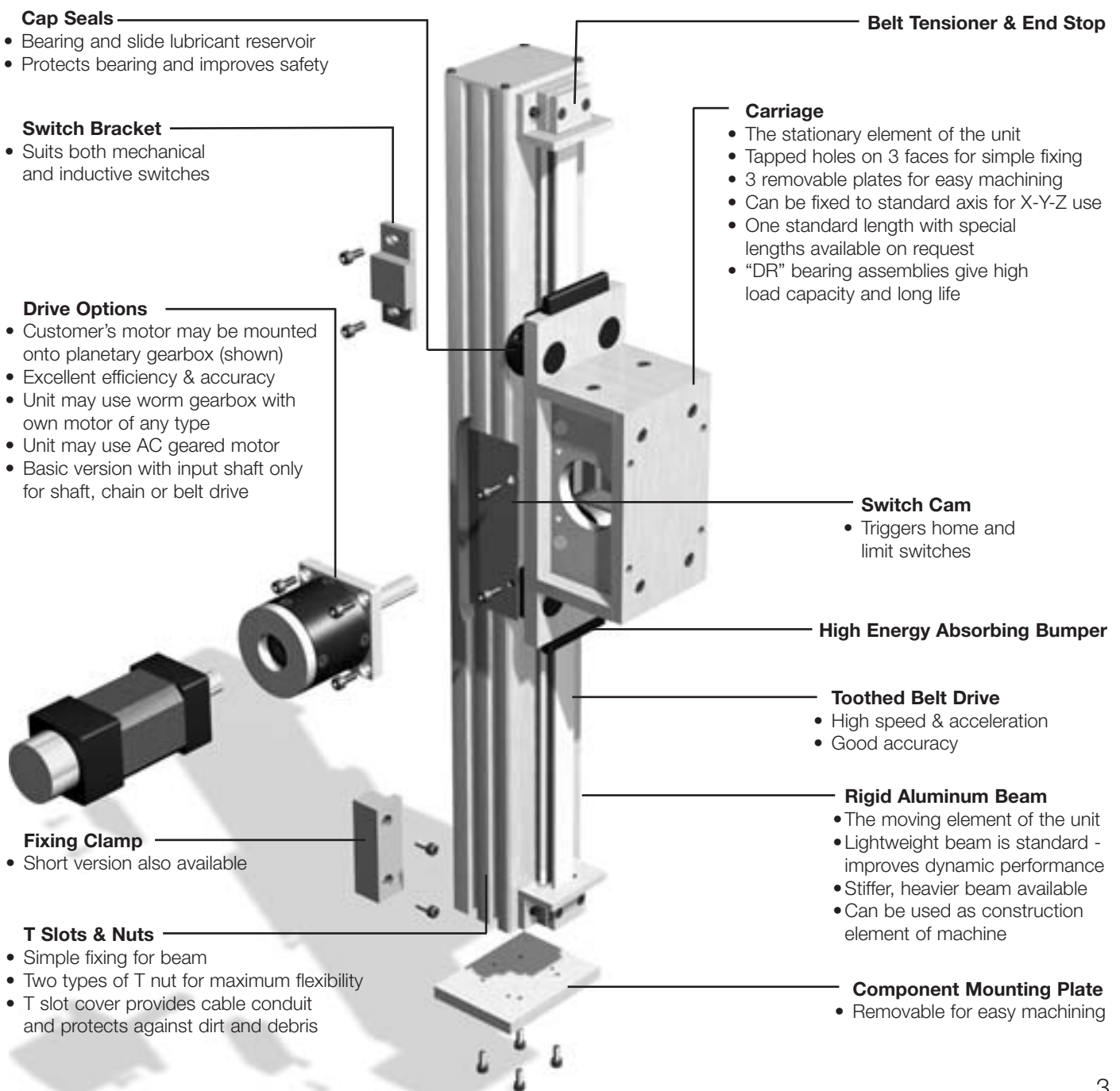

System Composition

Ancillary Mechanical Components

Bishop-Wisecarver can provide the components which are required to turn the mechanical transmission into a complete positioning unit.

Precision Planetary Gearboxes. Bishop-Wisecarver will supply any DLS with a planetary gearbox in an appropriate ratio engineered into the drive end unit. These gearboxes are very efficient and accurate, have a high load capacity, are very compact, and are compatible with many electric motors. Their high performance makes them particularly suitable for use with servo motors.

Worm Gearboxes. A high quality right angle drive unit which is directly coupled to the drive pulley. A very cost effective unit well suited for use with AC, stepper and servo motors. An optional torque limiter is available with this gearbox.

The use of common components enables both of the gearbox options to be more compact and lower cost than gearboxes from other sources. Bishop-Wisecarver can tailor the gearbox input flange to suit your motor.

Fixing clamps for DLS3 and 4 are available in both long (see pages 2 & 3) and short (see right) formats. These may be used to secure the DLS to a flat surface by holding on the lower T slot. Long clamps with holes for 2 fixing screws and short ones with a single fixing screw hole are available. The long versions may be used to secure one DLS beam onto the carriage of another similar one, which is useful for constructing X-Y and X-Y-Z movements (see application on page 7).

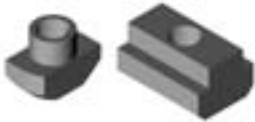

T Nuts - Two versions are available: the quick-fit type can be inserted into a T slot and rotated through 90° to engage; the heavy duty type can only be inserted at the end of the T slot or through the optional T slot windows in the beam. The heavy duty type is stronger and is recommended for use on the lightweight beam. Both types are threaded M6 and have a retaining spring fitted to aid installation.

Switch brackets (see diagram on page 2) are used to secure standard format mechanical and inductive switches to the side of the DLS beam.

The **Switch Cam** is fixed to the side of the carriage and actuates the switches on the switch brackets.

T slot cover (see right) may be specified to secure wiring coming from position sensing switches and route this via the T slots to the controller. The cover may also be used to fill any unused areas of T slot, to avoid debris traps, or for aesthetic purposes.



Motors and Drives

Bishop-Wisecarver will supply the electrical components required to drive and position the mechanical transmissions. This enables the customer to buy a complete system from a single supplier with the knowledge that all aspects have been included in the design.

Motors. Bishop-Wisecarver offers a range of geared AC induction motors which use the same high quality worm gearboxes described above. Powers from 60W to 1.1kW are available as standard, with the motors protected to IP54 (higher ratings are available on request). In addition to the optional torque limiter available on the gearbox, customers may select a braked version of the motors, which have a failsafe electro-mechanical brake fitted to the non-drive end. Motors are finished in epoxy paint and suit 200-230/380-460V operation at 50/60Hz (for safety, motors are supplied star connected for 380-460V operation, so the connections must be changed to delta format for 200-230V operation which is suitable for use with AC motor drive).

AC Motor Drive. The Allen-Bradley Rockwell Automation 160 range Smart Speed Controllers are ideally suited to complement the HepcoMotion® DLS. Units with output power ratings from 0.37-1.5kW effectively drive all standard AC motor options. The units are compact, robust and easy to use. They are supplied as standard with a programming keypad module which allows the user to select a number of running speeds, ramp times, and other control parameters. The keypad module also allows the user to monitor applied frequency (relates to motor speed), current & voltage as well as having fault diagnostic functions. A separate line filter is also part of the standard package which ensures that the unit complies with the EU EMC directive (Electro-Magnetic Compatibility).



The unit can be configured to act as a brake, which is very useful for operating a DLS vertically or where there is a substantial load to decelerate (in some applications the unit may require the optional dynamic braking module).

There are 2 versions of the controller available. The Analog Signal Follower (SF) model may have the speed set by an external potentiometer, which is ideal for many simple applications. The alternative Preset Speed model (PS) has up to 8 speeds programmed in via the keypad, and these can be accessed by closing control inputs. This unit is ideal for use in conjunction with PLC control.

The units are protected to IP20 and may be panel mounted or fixed to a standard 35mm DIN rail.

Application Examples

Sheet Feeding Mechanism

The ability of the DLS to feed to a length is used in a sheet feeding mechanism for a vacuum moulding process. The AC motor is driven using the inverter, which in turn is controlled by a PLC which supervises the whole process. After a start signal from the PLC, the motor drives the axis until a limit switch signals to the PLC that the required length is achieved. The PLC can then instruct the remaining part of the machine cycle to proceed. The length can be varied to suit a particular mould size by either moving the switch, or having several switches corresponding to different mould tools.

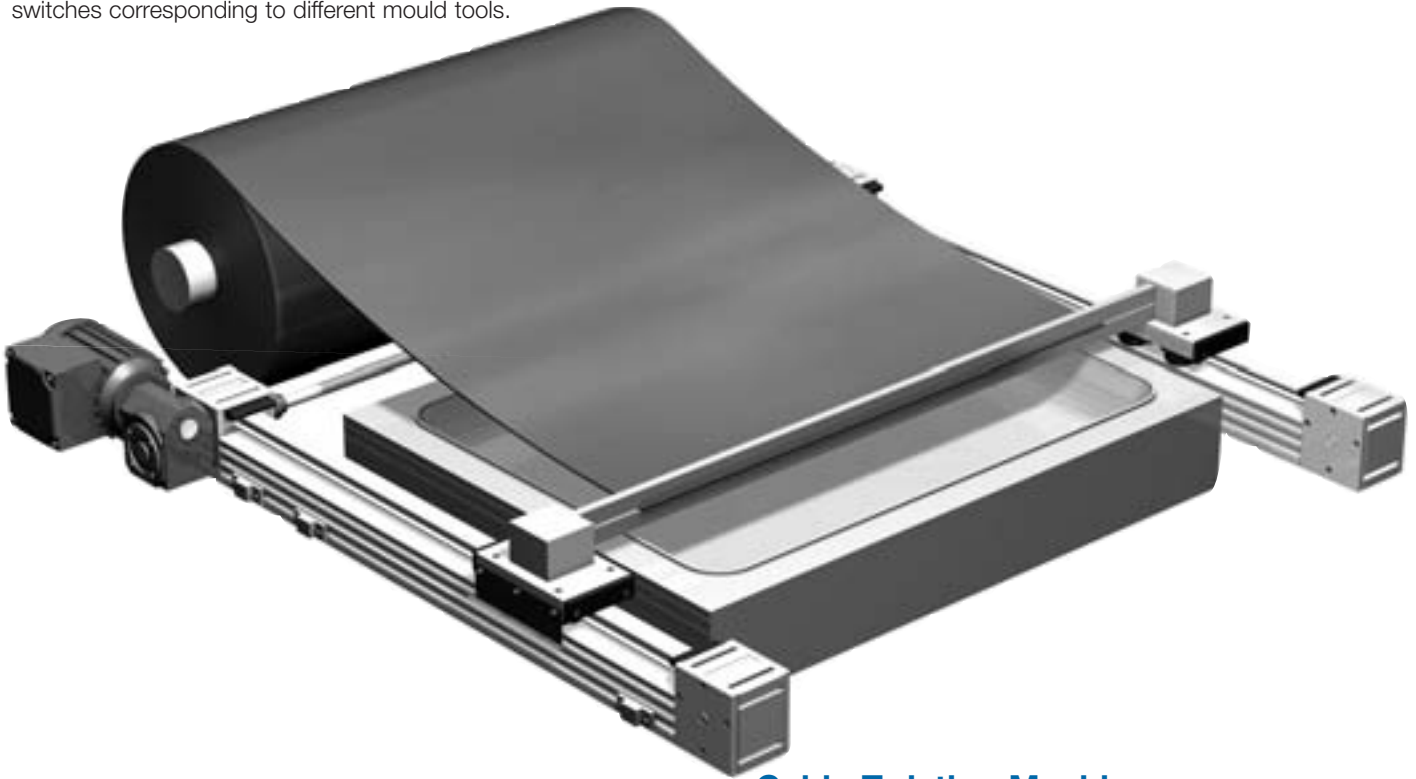

Cable Twisting Machine

The controllable movement of the DLS is used in this machine for making special twisted cables for incorporation into custom wiring looms. The servo motor driven head is mounted on the DLS carriage and is powered by a programmable drive/positioner. This interfaces with the AC motor, inverter and switch arrangement used to control the movement of the linear axis. The system allows for a consistent pre-determined twist angle to be achieved while the length is easily varied to produce the required dimension for the cable. The whole process is supervised by a PLC system, which is also used to control other related processes such as cutting and terminating the cables.

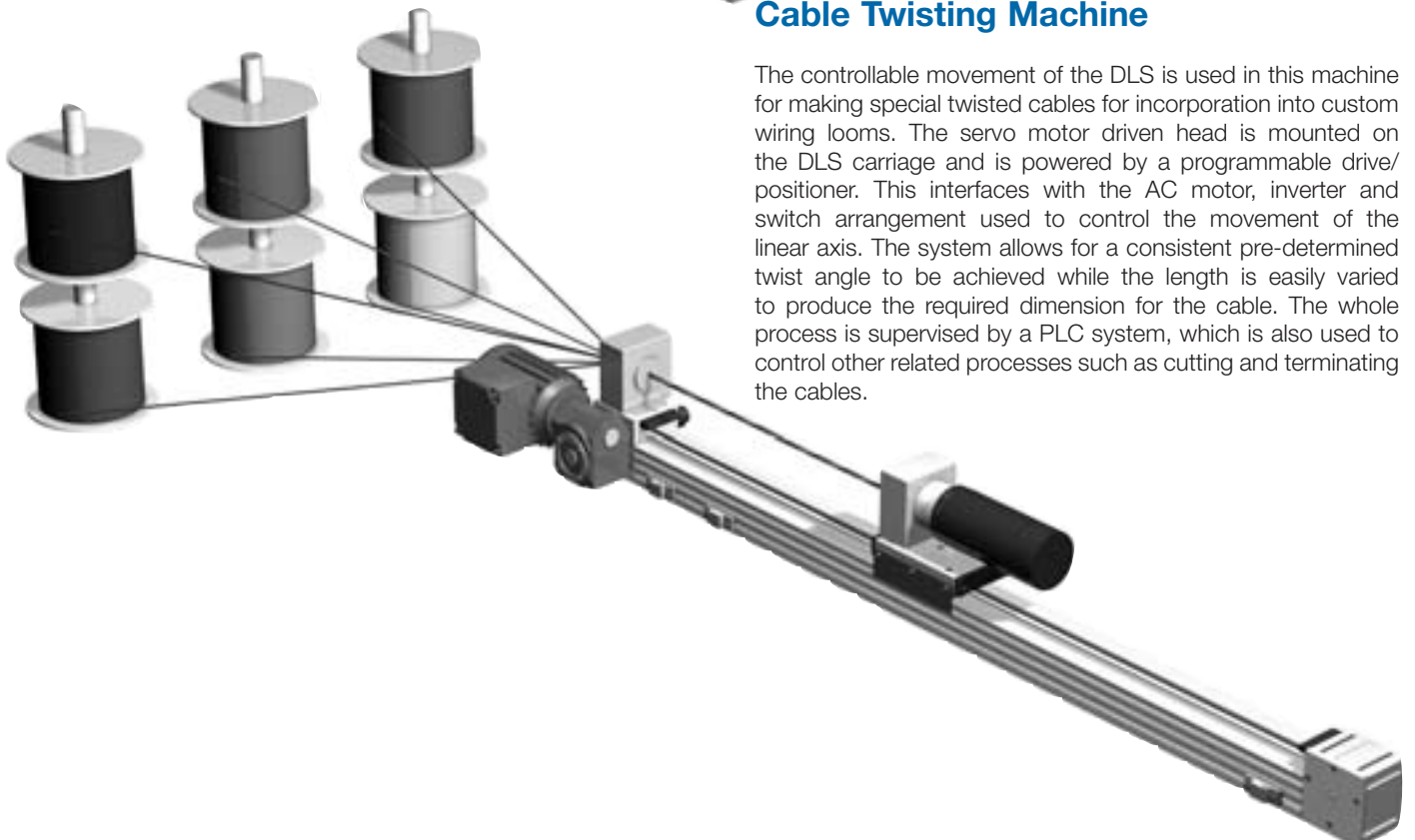

Application Examples

X-Z Transfer Unit

Used in automated system for picking up a basket of components, placing them in a cleaning tank and then returning the basket for subsequent processing. This unit uses a DLS3 standard unit with fitted AC geared motor for the X-axis, and a cantilever axis for the vertical Z-axis. The cantilever axis is fitted with a brake motor option to provide a holding force while this axis is stationary.

The unit has a number of stations on the X-axis defined by limit switches, and a PLC controls the whole process, commanding moves from any starting point to the target position in the cleaning tank.

Since the motion of the X & Z-axes never takes place at the same time, it is possible to use a single inverter drive to power both motors, therefore saving cost.

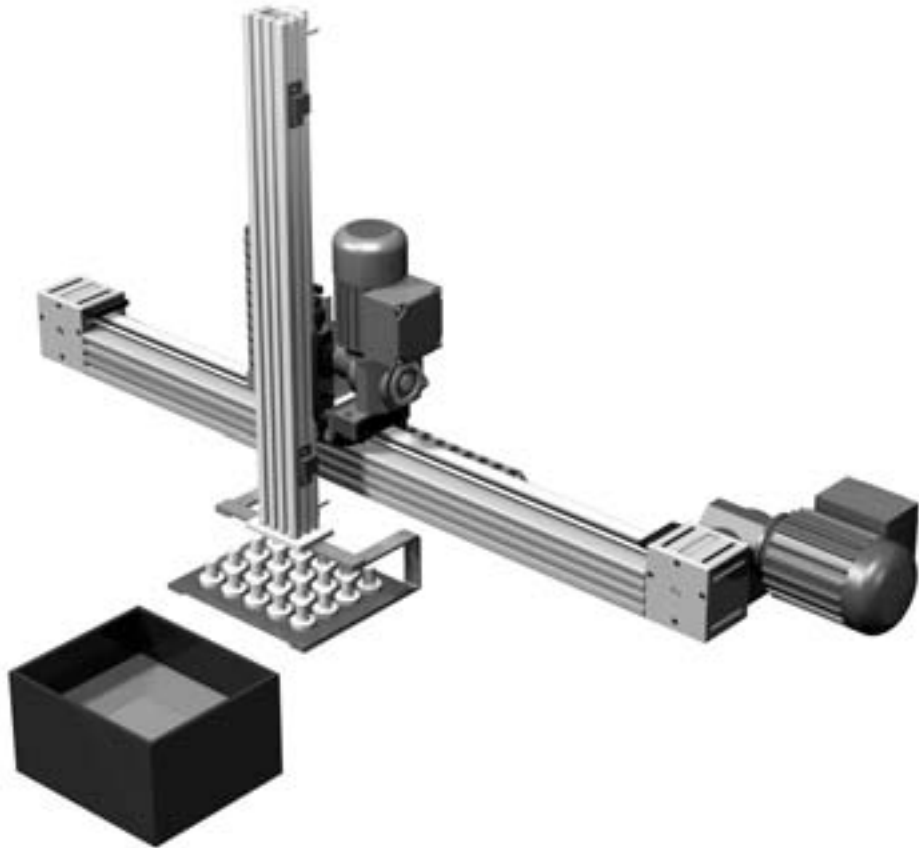

Waste Metal Picker

This device uses a DLS cantilever axis with a simple gripper fixed onto the component mounting plate. The unit has a fitted AC geared motor and is powered by the optional inverter. The motion is a simple extend to a position defined by the limit switch, stop while the waste metal with attached plastic components is removed from the tool of the injection moulding machine, and retract back to its 'home' position.

The cantilever axis is ideally suited to this duty, as the beam withdraws from the working area when not in use.

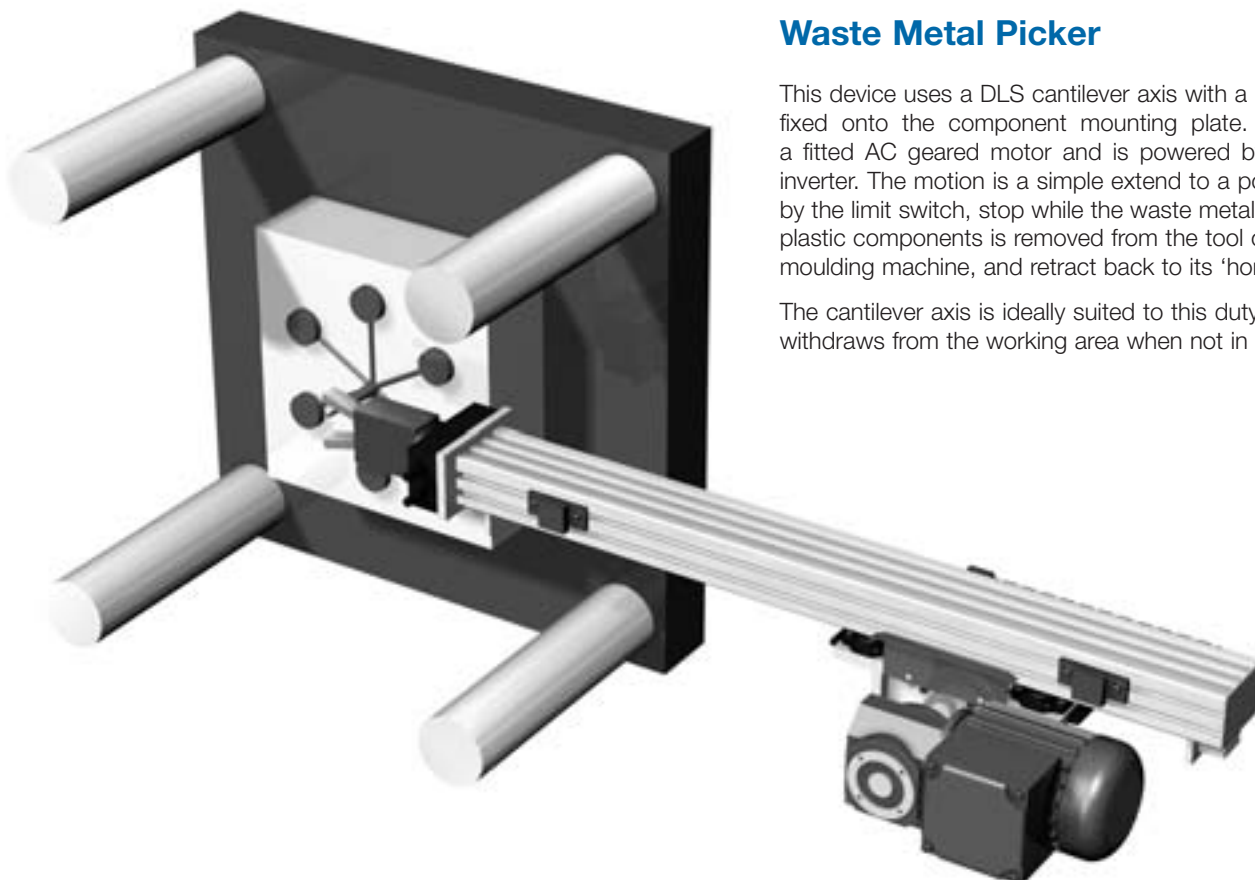



X-Y System

The master X-axis transmission is shown fitted with a high precision planetary gearbox and a servo motor. It is connected to the slave X-axis by a transmission shaft connecting between the output shaft of the first X-axis and the input shaft of the second X-axis by flexible couplings. The Y-axis transmission also has the same motor and gearbox arrangement fitted. It is connected to the carriages of the X-axes using the long fixing clamps which fit directly onto the carriage plate mounting holes.

Both master X-axis and the Y-axis have a switch cam on the carriage and a system of two limit switches and a home switch fitted.

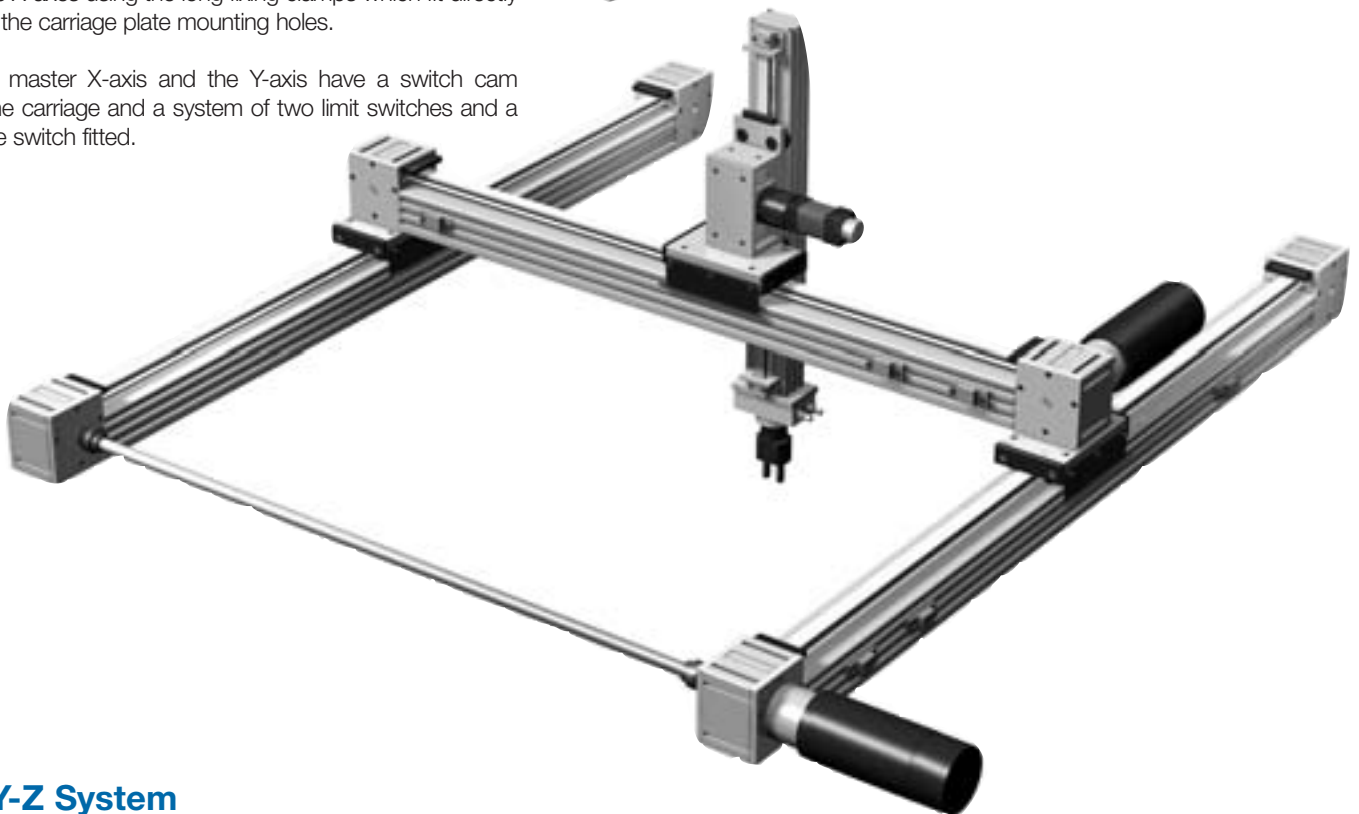

X-Y-Z System

The system illustrated is a logical extension of the basic X-Y system above. A short cantilever Z-axis is attached to the Y-axis to give controlled vertical motion. To minimize the moment load on the slides and bearings, the Y and Z-axes are connected directly by their carriages.

In systems where the movement is rapid and the moving axes are not very long, the Y and Z-axes can use the lightweight beam to minimize the moving mass, and so improve dynamic performance.

The cantilever Z axis is shown with the fitted planetary gearbox, which is well suited to the servomotor which is also shown.

It is possible to back-drive this gearbox. If this is not permissible, then a brake motor should be specified.

Data & Dimensions

DLS3 & 4 Standard Axis

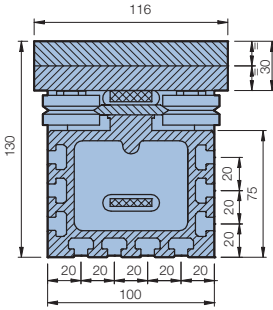

DLS4 Section A-A

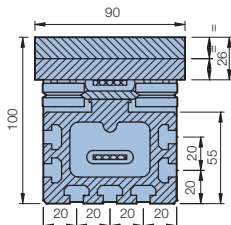

DLS3 Section A-A

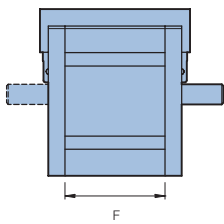

F

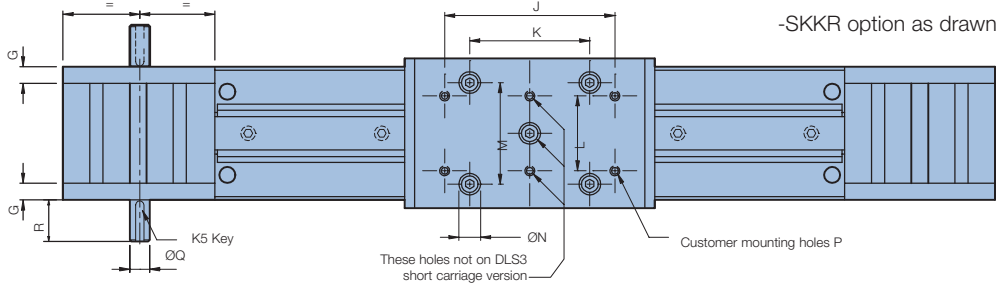

-SKKR option as drawn

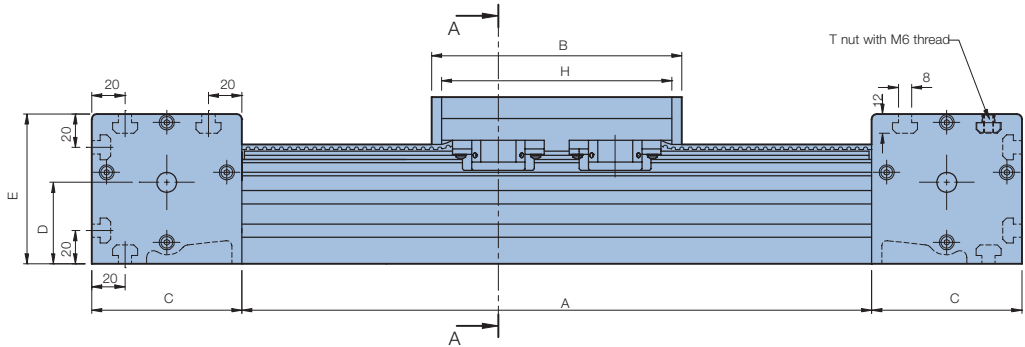

System	A	B	C	D	E	F	G*	H	J	K	L	M	N	P	Q	R
DLS3...S	to	150	91	49	91	62	9	138	100	97	48	70	10.5	M6x1	12	25
DLS3...L	order	230	91	49	91	62	9	218	200	180	48	70	10.5	M6x1	12	25
DLS4...S	to	200	111	63.5	120	76	12	184	120	130	65	90	13.5	M8x1.25	15	40
DLS4...L	order	280	111	63.5	120	76	12	264	180	215	65	90	13.5	M8x1.25	15	40

* Input flange thickness may vary with motor/gearbox selection.

A very popular option on the DLS is the fitted AC geared motor (see following page for full details). This may be mounted onto the DLS in the configurations shown below. Please use this guide when specifying your selection.

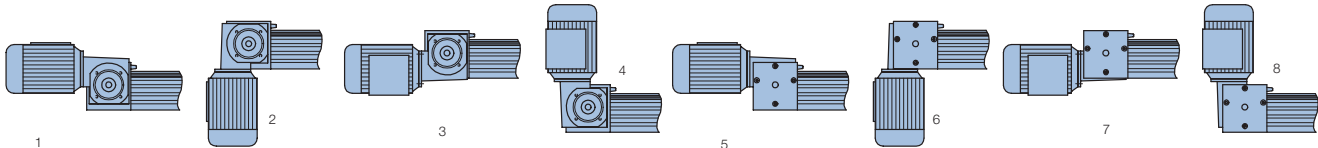

4 Terminal Box Mounting Options - Ref A - D
4 Terminal Box Cable Exit Options - Ref 1 - 4

The 8 Gearbox Mounting Options

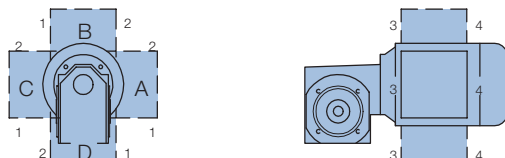

The geared motor may be fixed onto the DLS in any one of 8 positions. The terminal box on the motor may take one of 4 positions, with each having 4 options for the cable exit face. These alternatives allow the customer to select the ideal configuration for the application.

Note

Terminal box position A1 is the default.

AC Geared Motor Option

The optional AC geared motor will be the preferred choice for many applications as it provides an excellent combination of power, accuracy, flexibility and value.

Bishop-Wisecarver offers 3 phase squirrel cage motors to VDE 0530 supported by DIN 42677. Motors in 4 IEC frame sizes from 56 to 80 are offered, each with the choice of short (S) or long (L) field windings and 2 or 4 pole designs (running at approximately 2800 and 1400 rpm respectively). Powers from 60W to 1.1kW are available. Motors are rated at 400/230V, are protected to IP54, and are finished in blue epoxy paint as standard. Motors with alternative single and three phase windings, special finishes and enhanced IP protection rating are available on request.

The gearboxes are available in ratios from 5:1 to 75:1. Each uses a hardened and ground worm shaft running with a centrifugally cast bronze wheel, with oil bath lubrication. The wheel shaft is supported on high capacity rolling bearings in a high strength aluminum casting. This makes the gearbox strong, accurate, quiet and long lasting. It is also much lighter in weight and more compact than comparable units from other suppliers, making it particularly well suited for dynamic applications.

The gearbox is attached directly onto the side of the DLS drive box, using an ingenious hollow shafted arrangement. This direct drive eliminates the torsional flexibility which can compromise system accuracy if a flexible coupling is used. It is also much more compact and lower in cost than can be achieved by retrofitting a gearbox onto a DLS.

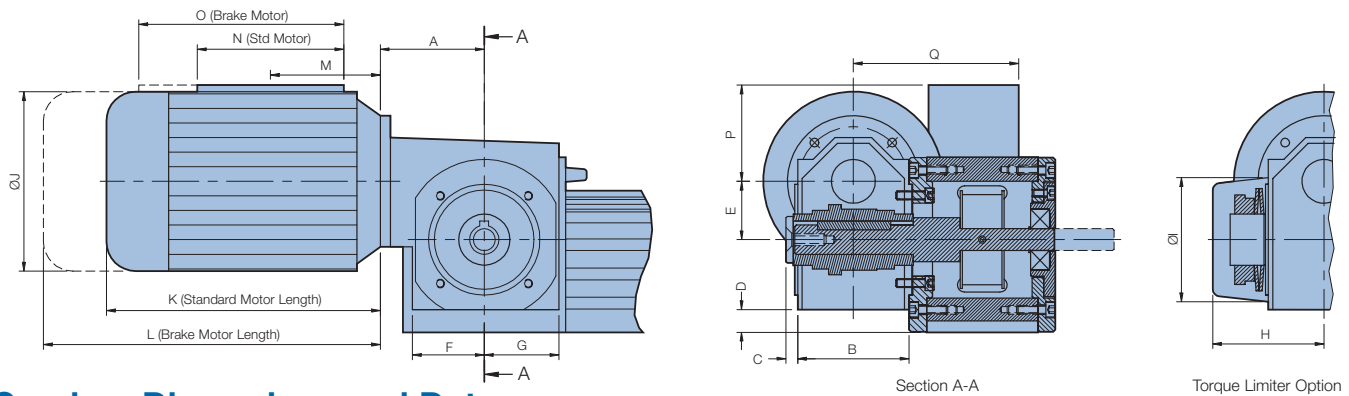

Gearbox Dimensions and Data

System	Suits	A	B	C	D	E	F	G	H	ØI	Weight	Rated Torque	Available Ratios
WG3...	DLS3	57	72	6.5	11	33	39	41	69	67	1.6kg	17Nm	5, 7, 10, 12, 15, 18, 24, 30, 38, 50, 75:1
WG4...	DLS4	71	76	8	15.5	40	49	51	76	85	2.5kg	32Nm	6.75, 8, 10, 12, 15, 20, 25, 30, 40, 50, 60, 70, 80:1

* The rated torque is a typical figure. The exact figure depends on the chosen ratio. The backlash is between 12 and 20 arc minutes depending on the ratio. The efficiency of the gearboxes is dependent on both input shaft speed and the ratio, with the efficiency being greater for higher speeds and shorter ratios. Typical efficiencies are in the range 75 - 90%. Please consult Bishop-Wisecarver for full details on your selection for torque backlash and efficiency.

Motor Dimensions and Data

Frame Size	Use With	ØJ	K	L	M	N	O	P	Q	Weight		Power			
										'S' Type	'L' Type	2 Pole 'S'	2 Pole 'L'	4 Pole 'S'	4 Pole 'L'
56	WG3	111	167	210	60	90	130	100	109	2.9kg	3.1kg	90W	120W	60W	90W
63	WG3&4	123	187	247	65	100	140	100	113	3.1 kg	3.6kg	180W	250W	120W	180W
71	WG3&4	138	212	272	65	100	140	110	125	5kg	6kg	370W	550W	250W	370W
80	WG4	156	233	300	82	115	160	135	137	8kg	9.5kg	750W	1100W	550W	750W

Notes

- For worm gearboxes with ratios of 29:1 and higher, a load will not back-drive a stationary gearbox (although the load may sustain movement in a gearbox which is already running). Ratios of 61:1 or greater will not back-drive dynamically.
- Gearbed motors which will not back-drive can provide a useful element of safety (for instance in vertical applications), but in many duties the brake motor option should be selected. The brake option conveniently fits on the end of the standard motor under an extended fan cowl (see diagram above).
- For operational details of the brake motor and torque limiter options, please see page 15.

Data & Dimensions

DLS Drive Options

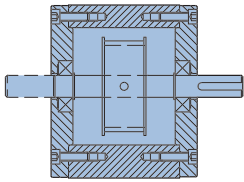

Basic version with shaft only. The basic DLS is supplied with a keyed input shaft, and the customer may also specify a similar output shaft. The input shaft is generally specified in those cases where the drive is mounted independently of the DLS and linked via a shaft (which we can supply), a belt and pulley or a similar arrangement. In some cases an output shaft will be needed, e.g. when it is necessary to run 2 parallel axes, the slave axis being driven from the output of the master (this is common in X-Y applications, see page 7).

The unit illustrated on the left has the input shaft and the optional output shaft is shown with a broken line. When ordering a shaft, the customer will need to specify the handing. A right handed shaft will appear on the right side of the drive end box when the DLS is seen from the drive end.

With High Precision Planetary Gearbox. Bishop-Wisecarver offers the DLS with the option of a fitted planetary gearbox (see right). The high accuracy, torque capacity and low inertia makes it well suited for servo motor and other demanding applications. The gearbox is engineered into the DLS drive end unit. Customers who purchase the system with a fitted gearbox will benefit from the compactness and efficiency associated with the simple coupling method used in this option. Details of the customer's motor shaft and flange will be required so that the gearbox can be tailored to suit.

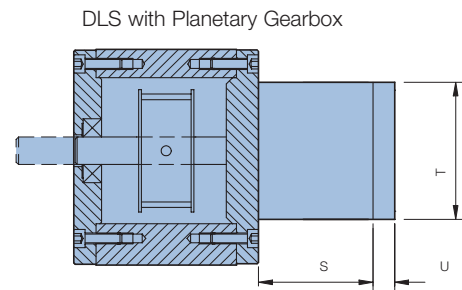

Gearbox Data

Gearbox	Use With	Ratio	Output Torque*	Inertia kgcm ²	Max Input Speed/rpm	Max Input Shaft Dia.	Back-lash	Effy %	S mm	T mm	U**	Gearbox Weight	Max Motor Weight***
DLSGB60-4	DLS3	4:1	16Nm	0.032	5000	12.7mm	<15'	90	35	60	8	0.65kg	2kg
DLSGB60-8	DLS3	8:1	15Nm	0.012	5000	10mm	<15'	90	35	60	8	0.65kg	2kg
DLSGB60-20	DLS3	20:1	44Nm	0.032	5000	9.5mm	<15'	85	47	60	8	0.82kg	2kg
DLSGB80-3	DLS4	3:1	40Nm	0.63	5000	20mm	<15'	90	46	80	12	1.6kg	4.5kg
DLSGB80-8	DLS4	8:1	50Nm	0.08	5000	14mm	<15'	90	46	80	12	1.6kg	4.5kg
DLSGB80-16	DLS4	16:1	120Nm	0.25	5000	16mm	<15'	85	63	80	12	2.2kg	4.5kg

* In use the torque will be limited by the maximum linear force - see page 20.

** Flange thickness shown is a typical figure but this may vary depending on the motor size.

*** If the weight of the motor attached to the gearbox exceeds this figure and the assembly is moving (e.g. on a Y-axis) then motor must be supported.

With Worm Gearbox. Full details of the AC geared motor option are included on page 9. The worm gearbox is available without the AC motor fitted, with a flange to suit IEC format motors. Dimensions of the gearbox are as shown on page 9.

With Special Flange to Suit Customer's Gearbox or Motor. Customers who wish to mount their own gearbox or motor directly to the DLS will benefit from the custom flange (option F). This allows the desired motor or gearbox to be connected to the drive end box without the need for a separate coupling. The unique floating bearing housing allows precise alignment of the customer's gearbox or motor, the pulley and the bearing, hence permitting direct connection. In many cases the motor flange will be a single plate of thickness 9mm on DLS3 and 12mm on DLS4 but in some cases it may be thicker, or a two piece plate may be required. In all cases Bishop-Wisecarver will supply a drawing of the unit with your order confirmation, and instructions on system assembly will be supplied with the unit.

The convenient and compact F option gearbox/motor flange will be a popular choice for customers who want to specify their own drive.

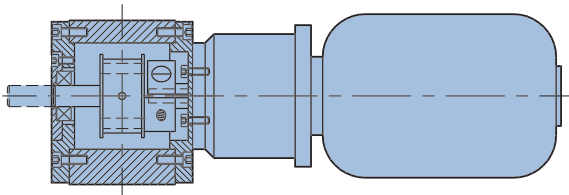

Please note: The use of the special motor flange places some load on the gearbox or motor shaft bearing. While this is acceptable for most gearboxes and some motors, customers are advised to check suitability before specifying this option.

Cantilever Axis

The important dimensions of the DLS3C are shown below. The main drawing shows the DLS3C in its standard form with an input and output shaft. Outline dimensions of the fitted AC geared motor and precision planetary gearbox options are included underneath. Full details of the AC geared motor and planetary gearbox options are given on pages 9 and 10.

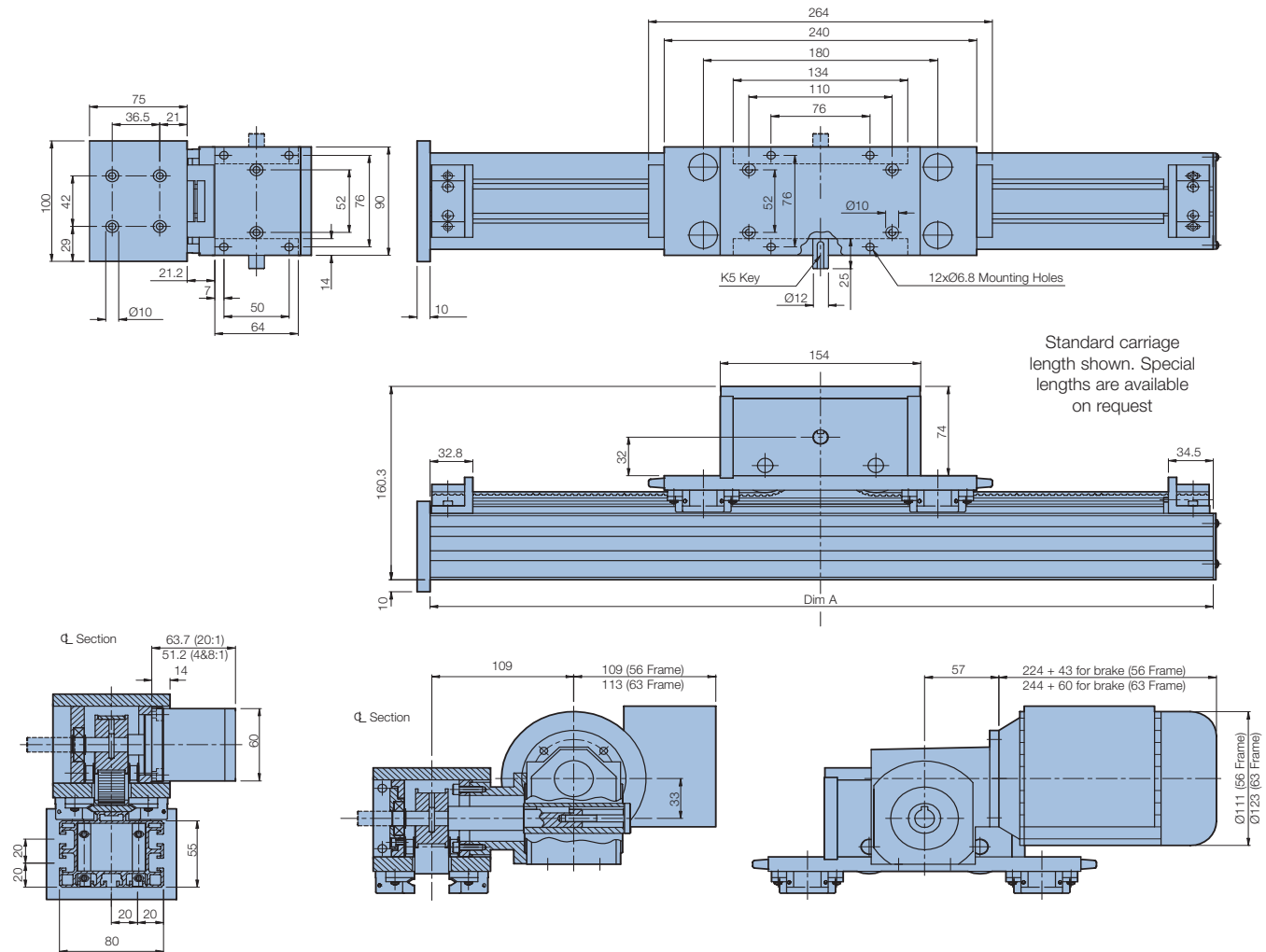

Notes

- 1) The largest AC motor which is compatible with the DLS3C is frame size 63.
- 2) The cantilever axis uses the lightweight beam (see page 12) to minimize the moving mass. Should the user require more stiffness, then the DLS3 "standard" beam may be selected as an option. See ordering details on page 22.
- 3) The cantilever axis may be connected directly to the carriage of a DLS3 or DLS4 standard axis as shown in the photograph on page 1. Please supply details of your application in these instances by submitting an Application Data Sheet on the Bishop-Wisecarver website.
- 4) The AC geared motor option may be fitted onto the DLS3C in one of the 8 positions shown below (viewing from the motor side of the carriage). A right handed unit will have the component mounting plate on the right hand end of the beam, and the belt tensioner on the left.
- 5) The terminal box and cable exit positions will be as indicated on page 8.

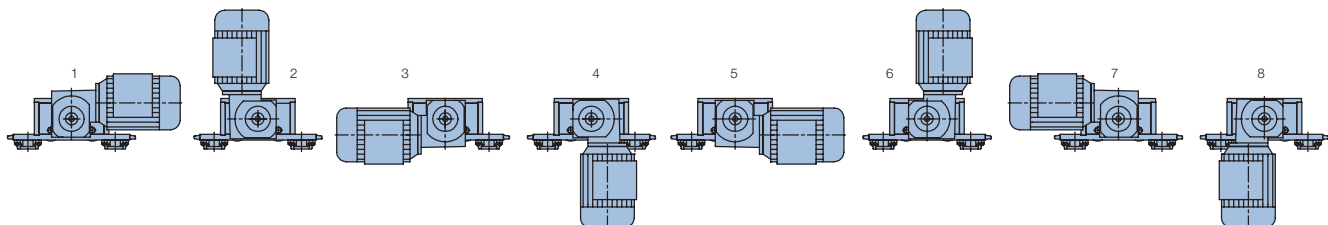

Data and Dimensions

Lightweight Beam

The DLS3 lightweight beam is half the weight of the standard version. This is a valuable benefit for any system, such as the Y-axis of a multi-axis system and any cantilever axis, where the beam moves. It has the same external dimensions as the standard beam, but is less stiff. This will increase deflection which may be significant in long unsupported spans. See page 19 for deflection calculations.

The lightweight beam is compatible with the standard fixing clamps and both quick-fit and heavy duty T nuts, although a reduction in the material thickness means that the quick-fit T nut can bruise the T slots if fully tightened. It is therefore recommended that the alternative heavy duty T nuts are used for high load fixing.

Fixing Clamps

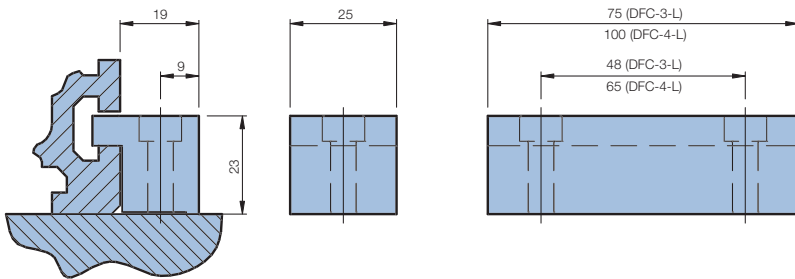

The fixing clamps are designed to hold the DLS beam or end units to a flat surface. The long clamps have two holes spaced to suit the customer mounting holes on the appropriate size of carriage (see application example 1 on page 7.)

The DFC-3-S/L (for use with DLS3) are counterbored to suit M6 socket cap head screws and the DFC-4-S/L (for use with DLS4) are counterbored to suit M8 socket cap head screws.

Drive Shaft and Support Bearings

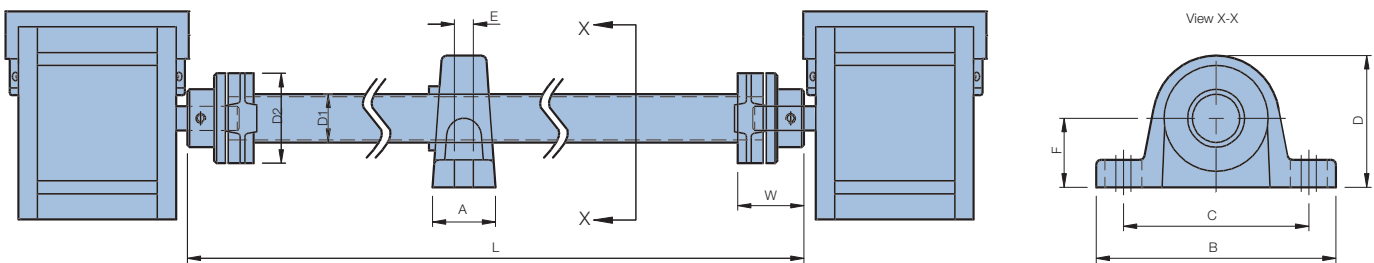

In many applications (e.g. on page 7) it is necessary to connect two parallel DLS axes together to work in tandem. In these cases a drive shaft should be specified. The drive shaft has been specially selected to have excellent torsional stiffness to ensure that “wind up” of the shaft and the consequent following error of one carriage to the other is minimized. The drive shaft is also designed to enable it to be fitted with both DLS units in position, as the shaft can be radially removed from the couplings without the need to separate the components axially.

Shaft	Use With	Working Torque	Linear Force		D1	D2	W	Weight/kg
			DLS3	DLS4				
GX1...	DLS3 & DLS4	10Nm	465N	314N	30	56	48	0.94 + 1.05 x L(m)
GX2...	DLS4 only	30Nm	N/A	943N	40	88	52	2.12 + 1.42 x L(m)

In high speed applications where long shafts are used it may be necessary to support the shaft with a pillow block type bearing to prevent “whipping”. See the table below for when to specify.

DLS & Shaft	Max Unsupported Length at Linear Speed				Support Bearing	Dimensions / mm					
	0.5m/s	1m/s	2m/s	5m/s		A	B	C	D	E	F
DLS3 & GX1	3500mm	2400mm	1700mm	1200mm	STL30	40	152	117	82	14	42.9
DLS4 & GX1	3500mm	2900mm	2100mm	1400mm	STL30	40	152	117	82	14	42.9
DLS4 & GX2	3800mm	3300mm	2300mm	1500mm	STL40	45	175	135	99	14	49.2

Choosing the Right System

The following section should be used by customers who wish to specify a complete system with fitted AC geared motor. Customers who wish to use the mechanical transmission and provide their own drive should refer to the linear drive calculations on page 21.

How to Select the Right DLS + AC Geared Motor Combination

The method of rating detailed below uses a simplified version of the definitive calculations. It will select the correct system in the vast majority of cases. For unusual and borderline cases the application may be referred to Bishop-Wisecarver for a more precise rating. To choose the right system configuration for a given duty, follow the 3 stages outlined below and on page 14:

- Choose the size of DLS transmission required, considering the following factors: i) The load to be supported by the slide (see page 18 for details of rating); ii) the linear force which is required (a DLS3 has a maximum linear working force of 560N, while for a DLS4 this figure is 1225N); iii) the bending strength of the beam (see page 19 for details of rating); and iv) the physical dimensions of the unit (see pages 8 - 11).
- Having decided whether a DLS3 or DLS4 unit is required, the user should then examine the relevant table (below for DLS3 & DLS3C and on page 14 for DLS4) to identify combinations of DLS and geared motor which have a suitable working speed range and nominal linear driving force. If a unit is intended to run at a single speed, it is recommended that a unit with a nominal speed close to the working speed is chosen. *(continued on next page)*

* The DLS will produce the Nominal Linear Force at speeds ranging from 50 to 120% of the Nominal Speed. The units will perform with a lower force and duty cycle over a much wider speed range from 10% to 200% of the Nominal Speed.

** The Gearbox Rated Linear Force is the force produced when the gearbox operates at a service factor of 1.4. This is based on fast operation for 8 hours per day. Allowable forces can be reduced or increased if the application is more or less arduous than this. Please contact Bishop-Wisecarver's Technical Department for details.

123

Entries shown in grey cells are preferred sizes.

DLS3 & DLS3C with AC Geared Motor

Nominal Speed m/s at 50Hz*	Motor Poles	Gearbox Ratio	Nominal Linear Force /N for System with Motor Size*						Gearbox Rated Linear Force /N**
			56 S	56 L	63 S	63 L	71 S	71 L	
1.26	2	5	34	55	96	142	222	339	429
0.9	2	7	59	88	138	205	314	477	486
0.63	2	10	87	126	205	293	437	687	513
0.6	4	5	55	96	134	214	302	435	483
0.52	2	12	109	155	239	348	561		528
0.43	4	7	84	138	197	302	435	645	543
0.42	2	15	134	187	293	435	645		513
0.36	2	18	163	226	356	492	770		498
0.3	4	10	126	201	285	435	603		573
0.27	2	24	211	290	448	631			513
0.25	4	12	151	239	335	519	728		588
0.21	2	30	251	343	528	743			498
0.2	4	15	184	289	435	645			573
0.17	2	38	315	429	656				516
0.17	4	18	218	339	477	728			558
0.13	2	50	366	497					406
0.13	4	24	276	435	603				573
0.1	4	30	322	519	728				573
0.09	2	75	467						379
0.08	4	38	435	645					603
0.06	4	50	477						453
0.04	4	75	561						424

Notes

- Combinations where the Nominal Linear Force exceeds the Gearbox Rated Linear Force or the belt working force are shown in *italic text* as in these cases it is possible to overload the gearbox. Often the use of a torque limiter or other technique will enable the DLS to function at a higher rating. Please consult Bishop-Wisecarver's Technical Department for details.
- Frame size 71 motors are not standard on the DLS3C cantilever axis.

Choosing the Right System

- 3) In many cases, there will be more than one combination which will satisfy the speed and force requirements. In these cases, the following secondary factors may be considered:
- For arduous applications, it is best to select the combination with the highest gearbox rated linear force.
 - For gearbox ratios of less than 29:1, the motor can be back-driven through the gearbox. This may be useful as it will allow the axis to be manually positioned with the power switched off. In some cases, however (for instance in lifting applications) back-driving may be undesirable. If this is the case, specify the electromagnetic brake option or select a higher gearbox ratio.
 - Two pole motors will be lighter than four pole for a given power.
 - For best dynamic performance, use a four pole motor. This will give sharper acceleration and more dynamic performance than a two pole motor driving through a gearbox with a higher ratio.
For a given load, a more powerful motor will generally accelerate the system more quickly than a less powerful one, but the benefit of increasing power will be small if loads are light.
It is possible to calculate the acceleration which can be achieved using the method detailed on pages 20-21.
 - Four pole motors keep the speed in the gearbox down, minimizing heating and maximizing life.
 - The marginal cost of extra motor power is low on an AC system. If in doubt between two sizes it is often best to specify larger, as there will usually be only a small extra cost.
 - All HepcoMotion® DLS units are offered on a competitive delivery.

DLS4 with AC Geared Motor

Nominal Speed m/s at 50Hz*	Motor Poles	Gearbox Ratio	Nominal Linear Force /N for System with Motor Size*						Gearbox Rated Linear Force /N**
			63 S	63 L	71 S	71 L	80 S	80 L	
1.38	2	6.75	67	113	186	300	441	639	539
1.16	2	8	87	135	220	356	498	752	630
0.93	2	10	118	181	300	441	639	922	666
0.78	2	12	144	215	356	526	752		630
0.67	4	6.75	101	178	271	385	611	837	602
0.62	2	15	186	300	418	641	922		648
0.56	4	8	133	218	300	469	724		703
0.48	2	20	250	363	556	846			666
0.45	4	10	172	300	385	583	894		743
0.38	2	25	301	434	696				612
0.38	4	12	203	328	469	696			703
0.32	2	30	364	522	792				648
0.3	4	15	271	413	583	866			723
0.24	2	40	458	652					648
0.23	4	20	356	554	750				750
0.19	2	50	566	801					703
0.18	4	25	413	639	866				683
0.16	2	60	564						430
0.15	4	30	498	752					723
0.14	2	70	737						557
0.11	4	40	611	951					723
0.09	4	50	752	1149					784
0.07	4	60	724						480
0.06	4	70	951						622

* The DLS will produce the Nominal Linear Force at speeds ranging from 50 to 120% of the Nominal Speed. The units will perform with a lower force and duty cycle over a much wider speed range from 10% to 200% of the Nominal Speed.

** The Gearbox Rated Linear Force is the force produced when the gearbox operates at a service factor of 1.4. This is based on fast operation for 8 hours per day. Allowable forces can be reduced or increased if the application is more or less arduous than this. Please contact Bishop-Wisecarver's Technical Department for details.

123

Entries shown in grey cells are preferred sizes.

Note 1) Combinations where the Nominal Linear Force exceeds the Gearbox Rated Linear Force are shown in *italic text* as in these cases, it is possible to overload the gearbox. Often the use of a torque limiter or other technique will enable the unit to function at this higher rating. The DLS4 pulley and belt are rated to 1225N, but to maintain a compact size, the standard gearbox limits the working linear force to a lower figure. If more linear force is required, a larger capacity gearbox may be fitted. Please contact Bishop-Wisecarver for details.

Having selected the right motor/gearbox combination, the user should then evaluate if any options are required for the geared motor:

Brake Motor Option

The brake lining is spring loaded against the friction plate, so the brake coil must be energized to release. In the event of a power failure, the brake is applied, so the unit is fail safe. The brake fits under an extended fan cowling on the end of the motor. Dimensions are shown on page 9. The brake requires nominal 200-230V AC power (which is rectified for the DC coil). This means that the brake should not be connected in parallel with a motor phase if the unit is powered by a controller, as the voltage reduces at low speeds, and the brake could be applied while the motor was still driving. The correct method would use the programmable relay output from the speed controller to switch the brake coil supply, or to control via a PLC.

Torque Limiter Option

It is possible for the geared motor to generate up to 3 times the nominal force on startup and this may be sufficient to cause a problem with the customer's application or in some cases (identified in *italics* in the relevant table on page 13) to damage the DLS transmission. In these cases, a Torque Limiter may be specified on the gearbox. The maximum torque is set by tightening a lock nut to the desired level. In the event of the torque or force generated exceeding the preset level, the friction clutch will slip. Dimensions are shown on page 9.

Motor Options

The standard 3 phase geared motor is protected to IP54 and is finished in dark blue epoxy paint. It is suitable for running at 200-230V 50/60Hz 3Ø with windings in delta (Δ) connection and 380-460V 50/60Hz 3Ø in star (Y) connection (motors are supplied configured for Y connection).

Motors with enhanced IP rating, special finishes and a range of alternative single and three phase windings can be supplied on request. Contact Bishop-Wisecarver for details.

Allen-Bradley Bulletin 160 Smart Speed Controller

This will allow the user to drive the AC geared motor and the DLS over a range of programmable speeds and accelerations. There are two types of units, which differ in the way that the desired speed is selected: The Analog Signal Follower version has the speed set by a control voltage (which can easily be generated with a potentiometer). The preset speed model has up to 8 operating speeds which are simply programmed in via the keypad provided. Versions are available to operate on single or 3 phase supplies (note that all types create 3 phase output to drive standard 3 phase motors).

The Smart Speed Controllers are available in 4 power ratings to suit the range of AC geared motors:

Motor Sizes	Required Controller Power
80 L/2	1.5kW
80 S/2 & 80 L/4	0.75kW
80 S/4 & 71 L/2	0.55kW
71 L/4, 71 S/2 & 71 S/4 all 56 & 63 frame motors	0.37kW

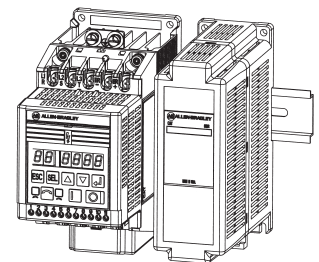

Bulletin 160 shown DIN rail mounted with capacitor module

An external **Capacitor Module** can be fitted for extended "ride-through" capabilities (reduces the risk of nuisance tripping on poor supplies) or improved inherent braking performance (note that this will improve the braking of the drive but is of no comparison to what is available with the dynamic braking unit). This unit is supplied as standard with the 1.5kW 1 phase 230V unit.

To ensure that the unit does not emit or react to excessive electromagnetic interference and to ensure compliance with EU EMC directive, units are supplied with a separate **line filter**. This unit is designed such that the controller can be attached directly on top of it, with tapped holes provided.

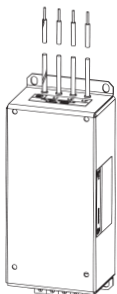

If the system is required to act as a dynamic brake (e.g. if the unit is lowering or decelerating a heavy load) it will be necessary to specify the **dynamic braking module**.

Line Filter is supplied as standard with all Speed Controllers

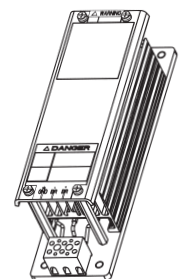

Optional Dynamic Braking Module

Choosing the Right System

System Configurations

In some simple applications, it is possible to achieve the desired performance using the Allen-Bradley Smart Speed Controller as the only means of control: for instance if the duty only requires the DLS to oscillate between two positions on a single axis at a prescribed speed and acceleration, this function can be achieved using the circuit diagram shown below:

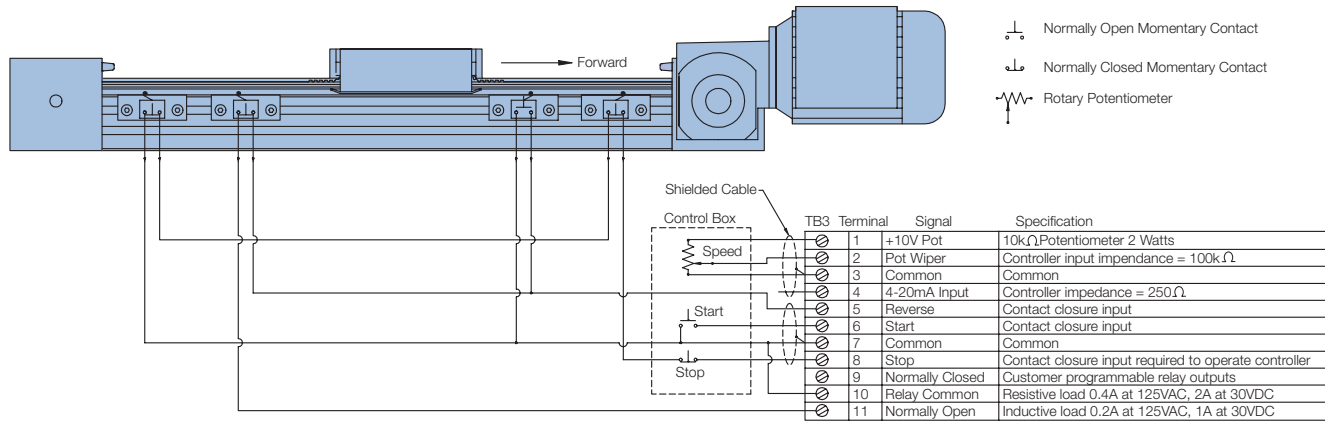

The diagram above shows the Analog Signal Follower model connected up to start and stop switches with a potentiometer on the control box enclosure, and to reversing and limit switches on the DLS beam. With parameter 46 set to zero (3-wire control) and parameter 47 set to 3 (internal relay switches when the motor runs in reverse) the unit will reciprocate at the set speed and programmed acceleration. A similar arrangement can be produced with the Preset Speed Model, where each of the preset speeds can be programmed in. In this case the potentiometer would be substituted for 3 switches.

This arrangement requires a minimum of hardware to achieve the desired functionality. The customer must fully evaluate the consequences of all switch permutations and ensure that the response meets the requirements for safety and function.

It is possible to extend the functionality of the system using external relay logic, but if there is much more complexity, it will be usual to use a Programmable Logic Controller (PLC) to supervise the control of the DLS (and often the remainder of the machine). In such cases, the Preset Speed Model of drive should be selected. A sample circuit diagram for the control of a system in conjunction with a PLC controller is included below:

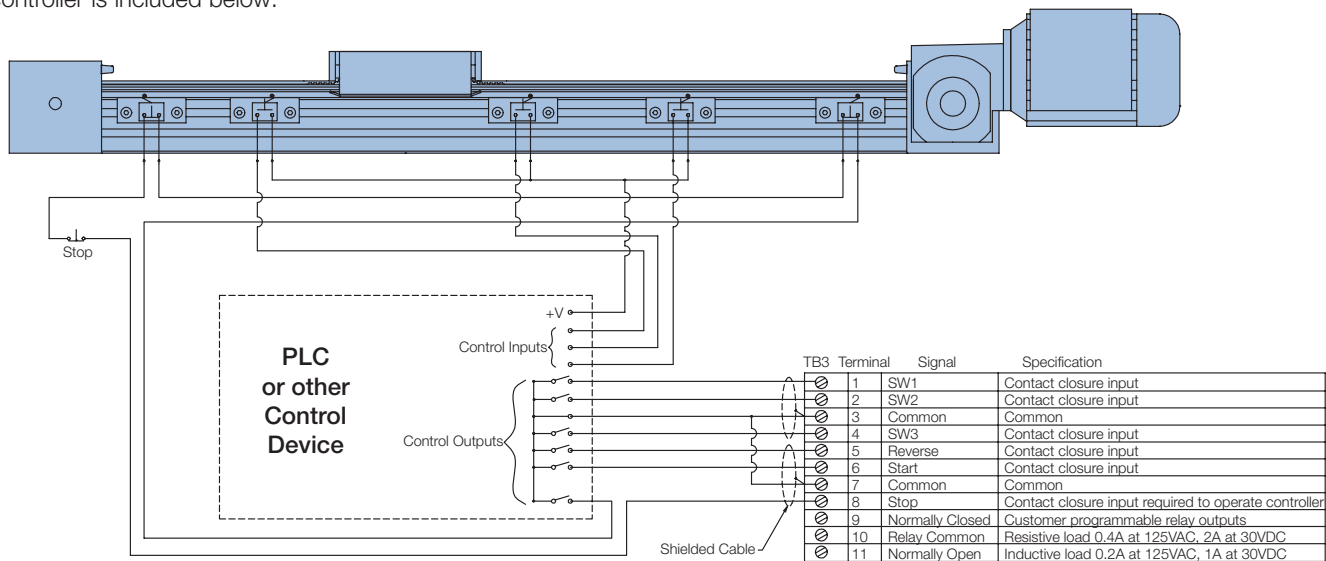

The diagram above shows the Preset Speed model connected to a controlling PLC. As in the previous example, the limit switches are connected to the Smart Speed Controller, and the drive is stopped if either of them, or the emergency stop button is switched. In this case 3 position switches (it could be many more) are connected to the PLC and provide information on position. The PLC communicates with the controller via the 3 switch inputs (which enable 8 speeds to be selected) and the Start, Stop and Reverse inputs. This gives the PLC full control.

Many other arrangements are possible: Some applications may benefit from communicating with a PLC using the special Devicenet option on the drive. Contact Bishop-Wisecarver for details.

System Accuracy & Repeatability

A critical feature of the DLS system used in conjunction with an AC geared motor is that it does not have any position measurement or feedback, with positioning dependent upon the unit having a switch at the desired stopping or reversing position. If the unit advances to a switch, the ramp down command is issued as the switch closes, however as some time is required for the system to stop, then the carriage will overshoot the switch position by a distance which depends on the approach speed and the deceleration time. In high speed systems, this overrun can be quite substantial (10's of mm) although it will be repeatable. If the customer has an application where improved accuracy is required from the system, it may be useful to have 2 switches next to each other. When the carriage touches the first switch, the PLC commands the drive to slow to a low "approach" speed. This means that when it contacts the second switch, the overrun is minimized. Using this (or a similar) technique it is possible to maintain system repeatability to well below 0.5mm.

If the application requires even greater accuracy or more sophisticated position control, an alternative control system should be sought. In such instances, servo or stepper motor based systems driving the DLS through one of the suitable gearboxes should be considered. The accuracy will be partly determined by the motor and controller choice, but positioning to 0.1mm is achievable.

Application Recommendations

There are a number of general points regarding the use of DLS units which will apply whether the customer uses a motor and drive from Bishop-Wisecarver, or makes alternative arrangements. **The following points should be observed to ensure that the system works reliably and safely.**

With any prime mover, measures are required to prevent the motion going outside prescribed boundaries which might lead to a system crash. In intelligent systems it is normal to have 3 levels of security in this regard: software limits are programmed into the position controller; limit switches will be positioned outside the software limits, which will stop the movement when they are tripped; and physical end stops act as a final backup to safely arrest motion which has gone past the limit switches.

Systems should be provided with an **emergency stop** facility. When using the supplied AC motor & drive, a dedicated controller input is provided for the stop function and this must be connected to common to allow the system to be run.

The end stops which are supplied as standard are made from a special synthetic material which has exceptional deformation and energy absorbing properties, and these provide suitable crash protection in many applications. **The end stops have a limited capacity safely to stop heavy and fast moving loads.** When determining whether or not the fitted end stops are sufficient protection in a system, it should be remembered that the end stop must absorb the energy from both the moving load and the motor. In lightly loaded but fast moving applications, **the motor can represent the largest load to stop**, and sufficient deceleration distance must be allowed to prevent the motor rotor deceleration from over straining the belt. In applications where it is necessary to provide additional protection against high impacts at the end of the stroke, it is **recommended that a separate shock absorber be fitted** to the system.

In many applications, the motor providing the driving force can be used to slow down the system as well as to speed it up. In some applications, notably when lifting heavy items, this arrangement may not give the required degree of safety. In such cases it may be beneficial to **fit a brake to the motor**. Bishop-Wisecarver can supply motors with a fitted brake on request.

When determining the length of a DLS axis, it is important to allow additional stroke length beyond the anticipated length of movement. This will allow, in the event of the carriage going beyond a limit switch, a **distance for the system to brake before the end stop** is encountered. In many cases a length equivalent to one pulley revolution would be appropriate for the overrun zone, but this will depend very much on the application.

Motor gearbox options have been selected to suit the capacity of associated DLS units. For critical applications where customers attach their own drive unit, an appropriate factor of safety must be applied to the combined system.

The DLS is intended to be used as a component of a larger machine system. Depending on the application, there may be potential hazards which the designer will need to consider and address as appropriate. Any or all of the carriage, beam, belt and shafts can move at high speeds, so may need to be guarded. If using electrical prime movers or signalling, suitable precautions should be taken to eliminate hazards due to electrical shock or malfunction. The driving force is provided by a steel reinforced toothed belt engaging in a pulley - the customer should ensure that the application does not have a failure mode which could over strain the belt to the point of damage, or that such a failure mode does not pose an unacceptable hazard.

If the customer requires further advice regarding the use of the DLS, please contact Bishop-Wisecarver and our trained Applications Engineers will be pleased to assist you.

Technical Section

Slide Load & Life: DLS3 and 4

The maximum load capacities for each size of DLS unit are given in the table below.

System	Max Moment Load (Nm)			Max Direct Load (N)	
	M _P	M _R	M _Y	L ₁	L ₂
DLS3...S	56	24	105	1600	3000
DLS3...L	120	24	225	1600	3000
DLS3C...	108	24	200	1600	3000
DLS4...S	165	70	280	3500	6000
DLS4...L	300	70	510	3500	6000

Figures are based on slide and carriage load capacities

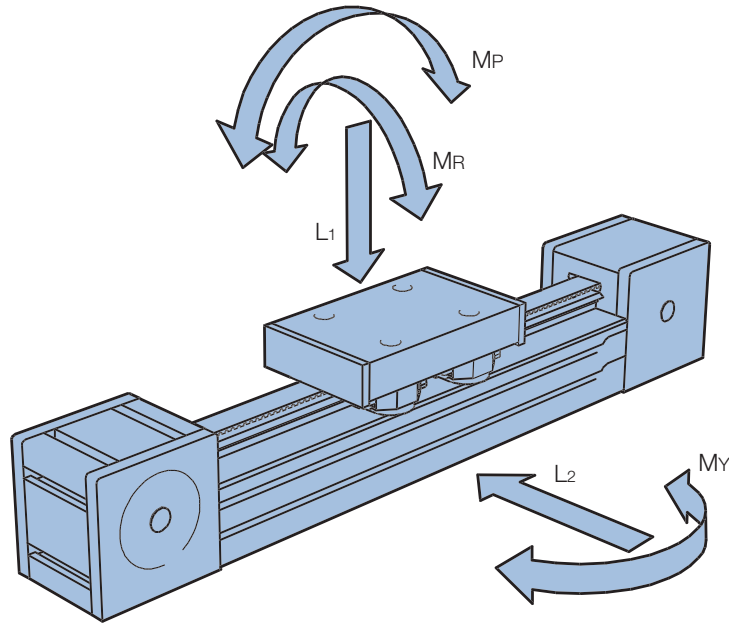

To calculate the life of a DLS unit first the load factor L_F should be calculated using the equation below:

$$L_F = \frac{M_P}{M_{P_{max}}} + \frac{M_R}{M_{R_{max}}} + \frac{M_Y}{M_{Y_{max}}} + \frac{L_1}{L_{1_{max}}} + \frac{L_2}{L_{2_{max}}}$$

The system life can then be calculated using the appropriate one of the following formulae:

$$\text{DLS3 Life (km)} = \frac{70}{(0.04 + 0.96L_F)^3}$$

$$\text{DLS4 Life (km)} = \frac{250}{(0.03 + 0.97L_F)^3}$$

Note: In many cantilever axis applications, the M_Y moment load will vary during the stroke. The accurate method to calculate the life will be to integrate the load with respect to position, but due to the complexity of the calculation it may be simplest to base calculations on a worst case basis (i.e. load at the end of the stroke). Please contact Bishop-Wisecarver for details.

Example Calculation

(Refer to DLS3 horizontal axis of application example on page 6 - "X-Z transfer unit")

The unit is required to lift a basket of components weighing 6kg. The cantilever axis is 600mm long and therefore weighs 6kg (see page 20) and the weight of the WG3 gearbox with 56L motor is 4.7kg (see page 9). In this design the center of mass of the basket and cantilever axis sits 40mm offset to the center of the carriage.

In this application both axes accelerate and move "slowly" so that we can ignore inertial forces. The total mass on the main axis carriage is therefore 6 + 6 + 4.7 = 16.7kg, offset 40mm (= 0.04m) to the center of the carriage in the M_R direction.

$$L_1 = 16.7 \times g = 16.7 \times 9.81 = 164N$$

$$M_R = 164 \times 0.04 = 6.6 \text{ Nm}$$

Entering these figures into the L_F equation above, we get L_F = 0.376. We can enter this figure into the life equation for the DLS3 as follows:

$$70 / (0.04 + 0.96 \times 0.376)^3 = 1080\text{km linear life}$$

Calculation of System Deflection

In a DLS application, the deflection of the working part of the system will be determined by two contributions which should be added together: There is the deflection of the carriage on the slide, and the bending of the beam to take into account. Where a long DLS axis spans a gap and is supported towards the ends only, then the beam bending is likely to be the dominant factor. Where the system is short, the beam is supported very close to the point where deflection is important, and in cantilever axis applications the beam deflection will be relatively small, and the carriage deflection term is likely to dominate.

Beam Deflection

The deflection of beam is accurately modelled by simple beam bending equations. The most common application is for a DLS axis supported at two points along its length. The equation below relates to the bending of a DLS beam supported at 2 such points separated by a distance L (mm), subjected to a load acting at the midpoint of the span. The deflection d (mm) due to the applied load W (N) is measured adjacent to the point of loading. This is the worst case.

$$d = \frac{WL^3}{48EI} \quad \text{equation 1}$$

In the equation 1 above, E is the Young's Modulus of the aluminum material of the beam which is 68,000N/mm². I is the moment of inertia of the section, which can be found in the table on page 20. The figure quoted for I_{x-x} will give the correct deflection for beams

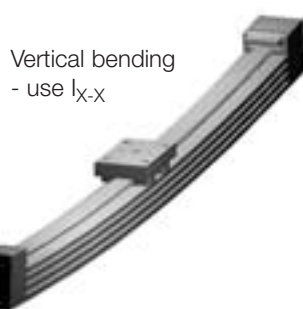

subject to vertical bending and I_{y-y} will give the correct deflection for beams subject to horizontal bending - see diagrams left and right:

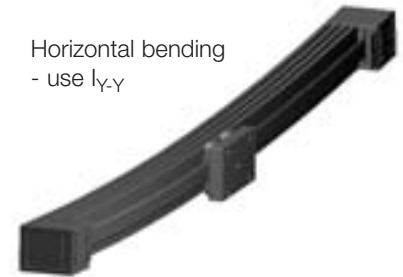

In many cases, particularly those with long unsupported spans, the deflection of the beam under its own weight will be significant. In the case of a beam of length L supported at its ends, the deflection at its center due to its own weight will be as given in equation 2 below:

$$d = \frac{5L^3}{384EI} \times \frac{LQg}{1000} \quad \text{equation 2}$$

Where Q is the mass of the beam and slide in kg/m, g = acceleration due to gravity (=9.81m/s²) and the other quantities are as per equation 1 above.

The beam deflection of cantilever axes can be calculated by similar methods: If a load W is applied at the end of the axis, and the distance from the point of load application to the center line of the carriage is L, then the beam deflection at the load is given by equation 3 below:

$$d = \frac{WL^3}{3EI} \quad \text{equation 3}$$

The beam deflection at the end of this cantilever axis under the action of its own weight will be given by equation 4 below (note that the meaning of symbols in equations 3 & 4 is the same as in equations 1 & 2):

$$d = \frac{L^3}{8EI} \times \frac{LQg}{1000} \quad \text{equation 4}$$

There are many other bending and torsion deflection modes which may be applicable to a DLS system, and if these are relevant in a particular application, then an appropriate engineering text should be consulted. The data included herein will allow such calculations to be completed.

Carriage Deflection

The deflection of a DLS carriage subject to any of the loading modes illustrated in the figure on page 18 is determined by dividing the loads on the carriage by the appropriate stiffness from the following table: The figures in the table below are for a typical system. Deflection may vary depending on the precise setup.

DLS	L ₁ Stiffness	L ₂ Stiffness	M _R Stiffness	M _Y Stiffness	M _P Stiffness
DLS3-S	14kN/mm	1.8kN/mm	8Nm/degree	40Nm/degree	300Nm/degree
DLS3-L	10kN/mm	1.8kN/mm	5Nm/degree	200Nm/degree	1500Nm/degree
DLS3C	12kN/mm	1.8kN/mm	5Nm/degree	200Nm/degree	1500Nm/degree
DLS4-S	20kN/mm	9kN/mm	200Nm/degree	400Nm/degree	800Nm/degree
DLS4-L	14kN/mm	9kN/mm	150Nm/degree	1300Nm/degree	3000Nm/degree

Technical Section

Linear Drive Calculations

This page details the method for determining the performance of a HepcoMotion® DLS when used with a customer's own choice of motor and gearbox. If you are specifying a standard supplied motor and gearbox, please see pages 13-14.

To determine the system performance with your selected motor and gearbox, perform the calculation steps below, numbered from 1 to 6. If this choice does not produce the required level of performance, the selection of motor and gearbox should be changed accordingly, and the calculations repeated.

This method calculates the maximum linear force generated by the DLS unit at the required speed, and compares it to the forces to overcome friction, accelerate the moving parts, and also do work if required (for example in raising the load). It is necessary that the motor torque safety factor is greater than 1, but the value will depend on the motor type and application.

The calculations below are appropriate for use in cases where the inertia of the motor and gearbox may be important in determining the performance of the system, which will usually be the case with servo and stepper motor based systems. In applications where the dynamic performance is less important (i.e. the rate of acceleration is not critical) it is acceptable to ignore the motor and gearbox inertia, and just add more to the safety factor. This will be particularly relevant for some DC and induction motors and geared units, for which motor and gearbox inertia figures are not readily available.

When specifying a motor and gearbox, the system should be rated for maximum acceleration at maximum speed. This is usually the most arduous condition. Care should be taken to allow for a suitable duty cycle for the motor as many can only provide high power for short periods.

Data Required for Calculations

DLS Performance Parameter			DLS3	DLS3C	DLS4
mass of carriage	M_C	(kg)	-	2.45	-
long		(kg)	1.65	-	2.75
short		(kg)	1.15	-	2.0
mass of belt per m	M_b	(kg)	0.068	0.068	0.16
pulley radius	r	(cm)	2.15	2.15	3.18
drive efficiency	d		0.9	0.9	0.9
break away friction	F_{ba}	(N)	25	25	40
coefficient of friction	μ		0.03	0.03	0.03
pulley moment of inertia (M.O.I.)	I_p	(kgcm ²)	0.3	0.4	1.3
max linear force	F_{max}	(N)	560	560	1225
mass of end box		(kg)	1.1	-	2.0
mass of beam and slide	M_{bs}	(kg/m)	7.0**	4.2	10.0
linear move per shaft rev		(m)	0.135	0.135	0.2
beam I_{x-x^*}		(mm ⁴)	750,000**	470,000	1,800,000
beam I_{y-y^*}		(mm ⁴)	1,300,000	780,000	2,700,000
mass of DLS3C mounting plate	M_p	(kg)	-	0.2	-

* Used in deflection calculations - see page 19.

** Figures shown are for standard beam. For lightweight beam version use figures as per DLS3C.

Key for Linear Drive Calculations

V_w (m/s)	required peak linear speed	I_m (kgcm ²)	motor moment of inertia (M.O.I.)
A_w (m/s ²)	required linear acceleration	I_g (kgcm ²)	gearbox M.O.I. seen from motor side (= 0 for no gearbox)
L_a (N)	applied load	η_g	gearbox efficiency
L (m)	beam/slide length	F_t (N)	total available linear force
M_L (kg)	applied mass	F_f (N)	force to overcome friction
S_w (rev/s)	motor speed	F_a (N)	force to accelerate all moving parts
T_w (Nm)	motor torque at speed S_w	F_w (N)	force required to do work
R_r	gearbox ratio (= 1 for no gearbox)	S_f	motor torque safety factor

Linear Drive Calculation for Standard Axis

In the following calculations, terminology & data used are taken from page 20.

- 1) Calculate the running speed of the motor - this then allows the motor torque at this speed to be read from the manufacturer's data.

$$S_w = \frac{V_w \times R_r \times 100}{2\pi r}$$

- 2) Calculate the total available linear force.

$$F_t = \frac{T_w \times \eta_d \times \eta_g \times R_r \times 100}{r}$$

- 3) Calculate the force required to accelerate the moving parts at the desired rate.

$$F_a = A_w \left\{ M_L + M_C + 2LM_b + \left(\frac{2I_p + R_r^2(I_m + I_g)}{r^2} \right) \right\}$$

- 4) Calculate the force required to overcome friction.

$$F_f = F_{ba} + \mu \times L_a$$

- 5) Calculate the force required to do work (example equation is for the unit moving a mass M_L plus the carriage up a slope of angle θ to the horizontal).

$$F_w = (M_L + M_C) \times g \times \sin\theta$$

- 6) Calculate the motor torque safety factor. If this is greater than 1 the DLS should perform the required duty, but it is recommended to have a higher value of S_f than this to provide a margin of safety.

$$S_f = \frac{F_t}{F_a + F_f + F_w}$$

Linear Drive Calculation for Cantilever Axis

The calculations for use with the cantilever axis are similar in approach to that for standard axes, but to allow for the system differences, equation 3 must be changed as follows:

- 3) Calculate the force required to accelerate the moving parts at the desired rate:

$$F_a = A_w \left\{ M_L + L(M_b + M_{bs}) + M_p + \left(\frac{I_p + R_r^2(I_m + I_g)}{r^2} \right) \right\}$$

Depending on the application, the calculation of the force required to do work (equation 5) may also need to change, for instance if the cantilever axis is required to move a mass M_L plus the carriage up a slope of angle θ to the horizontal, it is the weight of the beam, slide, mounting plate and load which move, while the carriage and drive are stationary. The modified version of equation 5 is as follows:

$$F_w = (L \times (M_{bs} + M_b) + M_p + M_L) \times g \times \sin\theta$$

With these modifications, the calculations will yield the true result.

Ordering Details DLS3 and 4

Main Unit

DLS 3 1885 S F K R L W

Prefix -	<u>DLS</u> identifies the product range
Size -	<u>3</u> indicates the small standard axis <u>4</u> indicates the large standard axis <u>3C</u> indicates the cantilever axis
Beam Length -	<u>1885</u> is the beam length (dim A on pages 8 & 11). Any length to 8000mm is available.
Carriage Length -	<u>S</u> indicates short <u>L</u> indicates long
Drive Input Type -	For DLS3C, leave this space blank <u>K</u> indicates a keyed shaft <u>G</u> indicates a fitted precision planetary gearbox* (but no motor) <u>W</u> indicates a fitted AC geared motor or worm gearbox* (as part of a complete system) <u>F</u> indicates a special gearbox/motor flange**
Drive Output Type -	<u>K</u> indicates a keyed shaft <u>Q</u> indicates no shaft
Input Handing -	<u>R</u> indicates drive input on the right hand of the drive box as seen from the drive end <u>L</u> indicates drive input on the left hand of the drive box as seen from the drive end (for fitted AC geared motor or worm gearbox on standard DLS, leave this space blank, as handing is covered by mounting configuration below. For DLS3C see page 11)
Lightweight Option -	Add letter <u>L</u> to the end of the part number if a lightweight beam is required. This is only available for the DLS3. Light beams are standard for DLS3C cantilever axes.
T Slot Windows -	These are needed for heavy duty type T nuts to fit on the beams of DLS standard axes (not required for DLS3C). Add letter <u>W</u> to the end of the part number if required.

* These options indicate that the gearbox or motor and gearbox will be included assembled onto the mechanical transmission. Details of the gearbox and/or geared motor should be included separately, see below.
** This flange will be tailored to suit your gearbox or motor. Please include gearbox/motor shaft and flange details with your order.

Fitted Worm Gearbox or AC Geared Motor

WG 3 R30 T 1 M 56 L 2 B A 1

Prefix -	<u>WG</u> identifies a fitted worm gearbox
Size -	<u>3</u> to suit a DLS3 <u>4</u> to suit a DLS4
Reduction Ratio -	<u>R30</u> identifies 30:1 (see page 9 for available options)
Torque Limiter -	<u>T</u> identifies that the torque limiter is fitted. Leave blank if not needed.
Gearbox Position -	Choose from <u>1</u> - <u>8</u> (see page 8 for options)
Input Option -	<u>F</u> indicates IEC adapter flange (customer to advise motor details) <u>M</u> indicates fitted AC motor
Frame Size -	<u>56</u> is the frame size of motor or flange (see pages 13 & 14 for options)
Field Length* -	<u>S</u> identifies short field winding <u>L</u> identifies long field winding
Motor Poles* -	<u>2</u> identifies 2 pole motor (~2800rpm @ 50Hz) <u>4</u> identifies 4 pole motor (~1400rpm @ 50Hz)
Brake Motor* -	<u>B</u> indicates that a motor brake is fitted. Leave blank if not needed.
Terminal Box* -	Orientation: choose from <u>A</u> - <u>D</u> (see page 8 for options)
Cable Exit Position* -	Choose from <u>1</u> - <u>4</u> (see page 8 for options)

* These characters are left blank if no motor is fitted.

Fitted Precision Planetary Gearbox

DLSGB 60 20 C

Prefix -	<u>DLSGB</u> identifies a fitted gearbox
Size -	<u>60</u> to suit DLS3 <u>80</u> to suit DLS4
Reduction Ratio -	DLSGB 60 available in <u>4</u> , <u>8</u> & <u>20</u> (:1) DLSGB 80 available in <u>3</u> , <u>8</u> & <u>16</u> (:1)
Input Flange -	<u>C</u> indicates that the gearbox flange will be tailored to suit the customer's motor*

* In this case the gearbox input flange will be tailored to suit your motor. Please include motor shaft and flange details with your order.

Mechanical Ancillary Components

Part Number

T Nut -	Quick fit type can be inserted into a T slot and rotated through 90° to engage. Heavy duty type recommended for arduous applications and on light beams.	RTN8M6 TN8M6
T Slot Cover -	An extruded UPVC cover available in lengths up to 8000mm. One is required per T slot. The <u>last 4 digits</u> relate to the length in mm.	TC8-1234
Fixing Clamp -	Specify size <u>3</u> or <u>4</u> depending on the size of DLS unit, and <u>S</u> (short) or <u>L</u> (long).	DFC 3 L
Switch Bracket -	Allows standard V3 pattern microswitches to be attached to the DLS. These come with the T nut and screw required to fix them to the DLS beam.	DSB8
Switch Cam -	Fixes to the DLS carriage to operate microswitches fixed with switch brackets. Specify <u>3</u> or <u>4</u> or <u>3C</u> depending on the size and type of unit. If this component is ordered with the DLS, the unit will be supplied with suitable fixing holes.	DSC 3
Drive Shaft -	Connects between the output shaft and the input shaft of two parallel DLS axes (see page 12). GX1 and GX2 have torque capacities of 10 and 30Nm respectively. The digit <u>3</u> or <u>4</u> following the D relates to the size of DLS units. The L <u>900</u> dimension is the length of the shaft (see page 12).	GX 2 - D4- L 900
Shaft Support - Bearing	A pillow block type housed bearing to support the shaft where the DLS units are widely spaced or fast moving. See page 12 for when to specify. STL <u>30</u> suits GX1 shafts, <u>40</u> suits GX2 shafts.	STL 40

Electrical Components

Part Number

Speed Controller - Model Series -	Intelligent speed controller to drive AC motors fitted to DLS. <u>160</u> indicates the Allen-Bradley Bulletin 160 range	160 AA 02 NPS1 P1
Supply Type -	<u>S-AA</u> for 200-240V 1Ø, <u>-AA</u> for 200-240 3Ø & <u>-AB</u> for 380-460V 3Ø	
Power Rating -	<u>02</u> for 0.37kW (2A), <u>03</u> for 0.55kW (3A), <u>04</u> for 0.75kW (4.5A) & <u>08</u> for 1.5kW (8A)	
Control Mode -	<u>NPS1</u> indicates the preset speed model, <u>NSF1</u> indicates analog signal follower model	
Keypad Module -	<u>P1</u> indicates that the unit is fitted with the programming keypad	
Line Filter -	All the above units are supplied with a separate line filter - see page 15.	
Capacitor Module -	<u>160S-CMA1</u> suits 200-240V 1Ø, <u>160-CMA1</u> suits 200-240V 3Ø & <u>160-CMB1</u> suits 380-460V 3Ø. The capacitor module is supplied as standard with 1.5kW 1Ø 200-240V unit.	
Dynamic Braking Module		160-BM A 1
Supply Type -	<u>A</u> indicates 200-240V 1Ø & 3Ø, <u>B</u> indicates 380-460V 3Ø	
Power Rating -	<u>1</u> suits inverter powers up to 0.75kW, <u>2</u> suits 1.5kW drives	
Limit & Home - Switch	Standard V3 pattern microswitch. The mechanical version DLS V7SWM has a roller actuator and is sealed to IP67. The inductive version DLS V7SWI is also sealed to IP67. Both switches are supplied with flying leads.	DLS-V7SW M

HepcoMotion® DLS5 Linear Transmission

The DLS5 unit is robustly built on a strong, compact aluminum beam fitted with one of Hepco's popular GV3 slides. The drive is provided by a 50AT10 timing belt and pulley to give an excellent combination of strength, speed and accuracy. Units are compatible with Hepco's MCS framework system and other driven products, including HDLS and DLS.

This is a brief overview of the product. Further details may be obtained from Bishop-Wisecarver's Technical Sales Department.

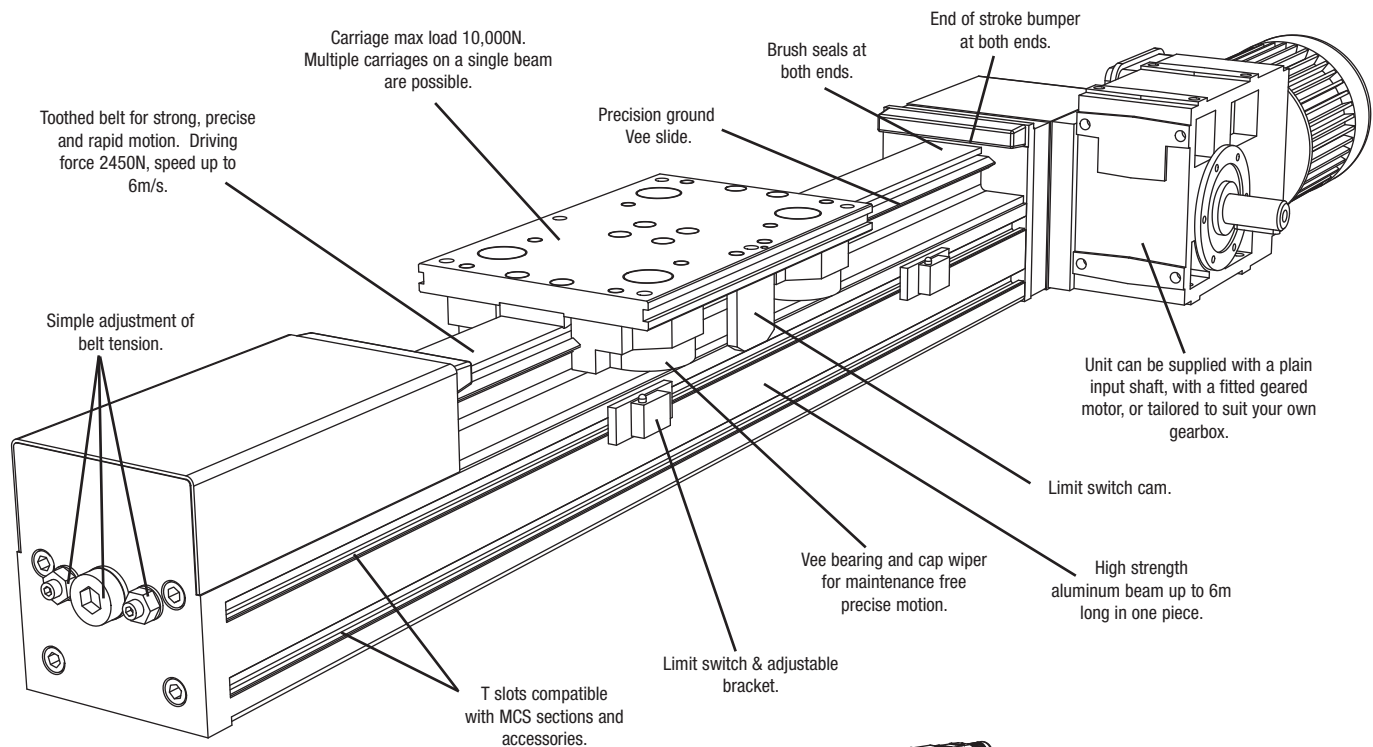

Application Example

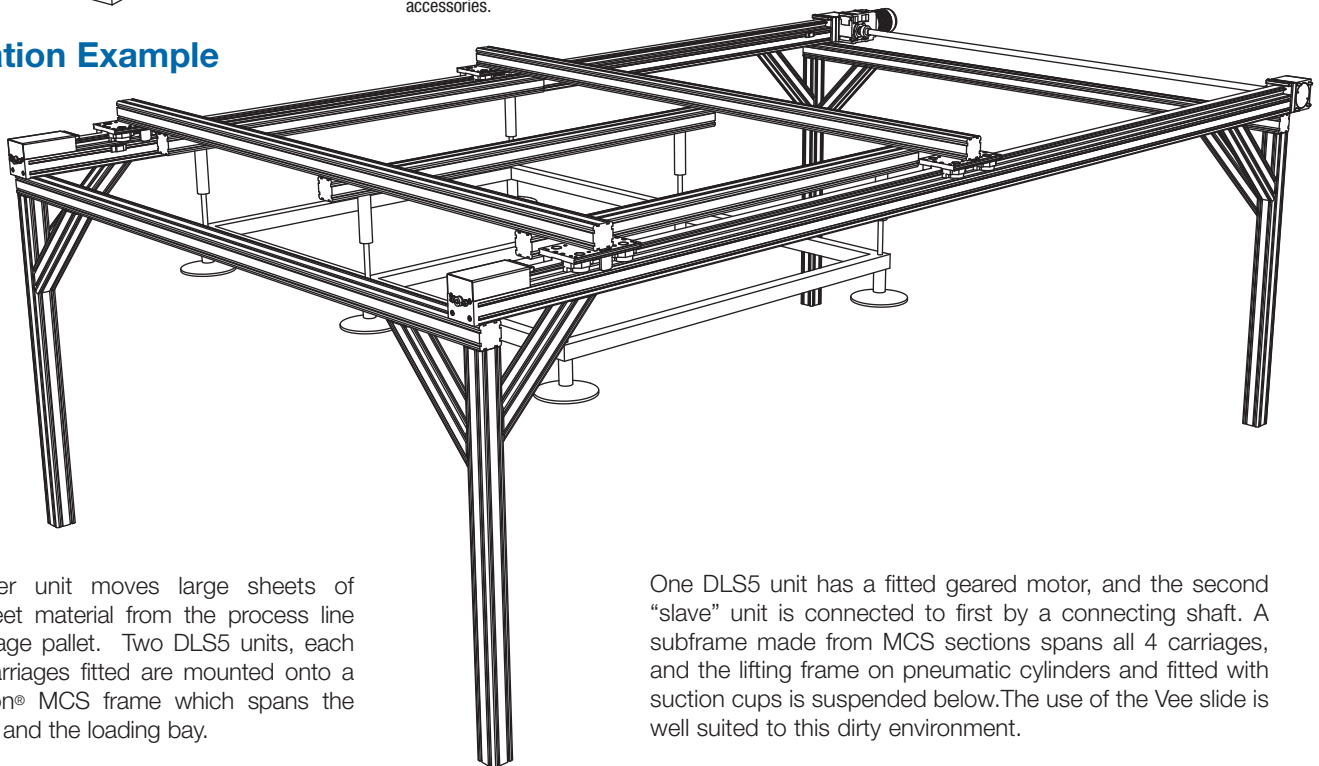

This transfer unit moves large sheets of building sheet material from the process line onto a storage pallet. Two DLS5 units, each with two carriages fitted are mounted onto a HepcoMotion® MCS frame which spans the product line and the loading bay.

One DLS5 unit has a fitted geared motor, and the second "slave" unit is connected to first by a connecting shaft. A subframe from MCS sections spans all 4 carriages, and the lifting frame on pneumatic cylinders and fitted with suction cups is suspended below. The use of the Vee slide is well suited to this dirty environment.

DLS5 Data and Dimensions

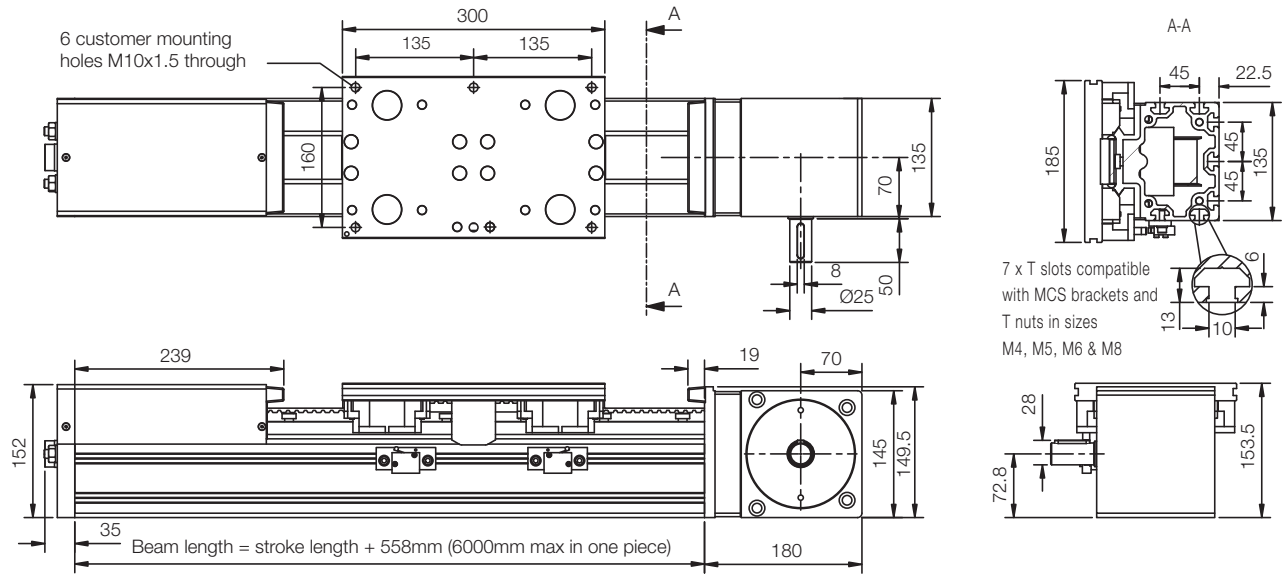

Load Capacities

The table below shows the maximum loading for the carriage in each possible loading mode. It also includes loads for 10,000km travel. This table is intended as a guide for initial selection only. Please send your application details to Bishop-Wisecarver and we will calculate the system Load/Life for you.

Carriage Type	L ₁	L ₂	M _R	M _Y	M _P
HDCS 64	max 10,000N @ 500km 3,600N @ 10,000km	max 10,000N @ 500km 3600N @ 10,000km	max 360Nm @ 500 km 130Nm @ 10,000 km	max 990Nm @ 500 km 360Nm @ 10,000 km	max 990Nm @ 500 km 360Nm @ 10,000 km

Data Required for Calculations

Data for DLS5 is included in the table below.

mass of carriage	M _c	5.2 kg	max linear force	F _{max}	2450 N
mass of belt per m	M _b	0.32 kg	mass of unit with 1000mm beam*		34 kg
pulley radius	r	5.1cm	extra mass per 1000mm beam		17.5 kg
drive efficiency	η _d	0.9	linear move per shaft rev		0.32 m
break away friction	F _{ba}	40 N	beam I _{x-x}		6,100,000 mm ⁴
coefficient of friction	μ	0.03	beam I _{y-y}		8,100,000 mm ⁴
pulley moment of inertia (M.O.I.)	I _p	30 kgcm ²			

* assumes one shaft, no gearbox

Ordering Details

Product range	DLS5	3018	K	0	L
Beam length in mm - 6000 max in one piece					
Drive input type -	K indicates a keyed input shaft				
	W indicates a fitted geared motor or gearbox				
Drive output type -	K indicates a keyed output shaft				
	Q indicates no shaft				
Input handing -	R or L indicates drive input on the Right or Left hand side as viewed from the drive end				

Note: Customers requiring further details of optional geared motors or gearbox fitting kits should contact Bishop-Wisecarver.

Bishop-Wisecarver Corporation: Manufacturer of the original DualVee® guide wheel and industry leader in guided motion technology, and exclusive North and Central American partner and distributor for HepcoMotion products since 1984.

BISHOPWISECARVER®

Bishop-Wisecarver

DualVee® Guide Wheels
LoPro® Linear Motion System
MinVee® Linear Slide System
QuickTrak® Linear Motion System
SRX-150 Linear Motion System
UtiliTrak® Linear Motion Guide



HepcoMotion®

DAPDU2 Double Acting Profile Driven Unit
DLS Driven Linear System
DTS Driven Track System
GV3 Linear Guidance and Transmission System
HDCB Heavy Duty Compact Beam
HDCS Heavy Duty Compact Screw
HDLS Heavy Duty Driven Linear System
HDRT Heavy Duty Ring Slides and Track System
HDS Heavy Duty Slide System
MHD Heavy Duty Track Roller Guidance System
MCS Machine Construction System
PDU2 Profile Driven Unit
PRT Precision Ring and Track System
PSD120 Profile Screw Driven Unit
SBD Sealed Belt Drive
Simple-Select®
SL2 Stainless Steel Based Slide System

PRODUCT ORDERS

Please call Bishop-Wisecarver with your specific length requirements and additional ordering assistance. Our technical staff is available to assist with information specific to your application.

Bishop-Wisecarver provides a written one year limited warranty assuring the customer that its products conform to published specifications and are free from defects in material or workmanship.

Complete terms and conditions and warranty information is available at www.bwc.com/about_conditions.vp.html

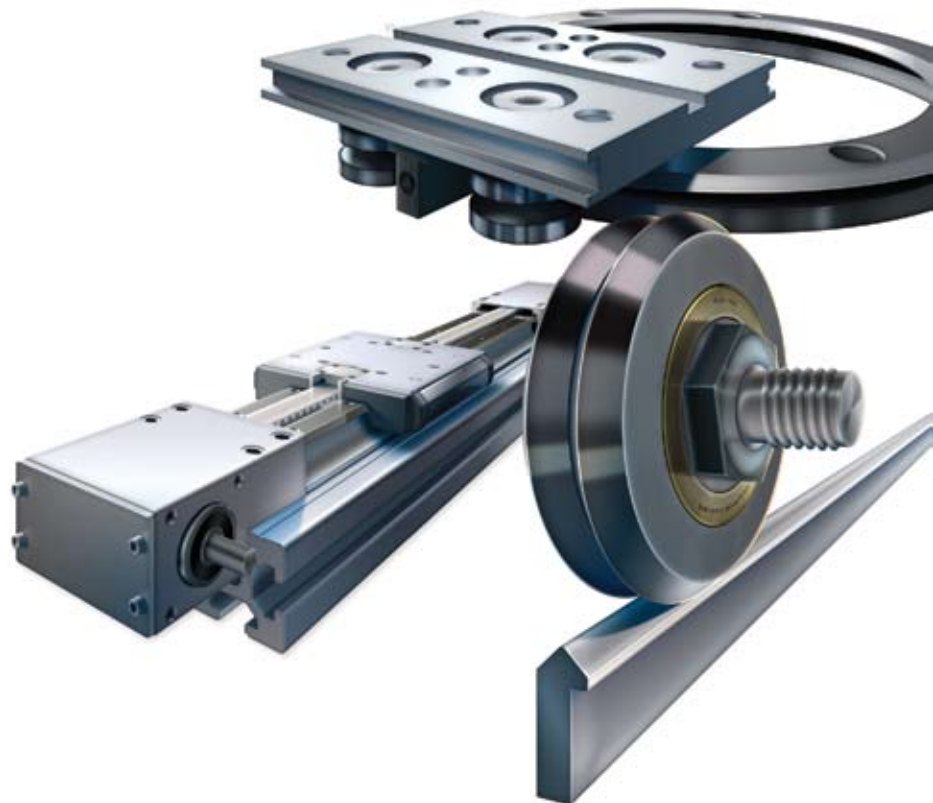

888.580.8272 925.439.8272 www.bwc.com

© Bishop-Wisecarver Corporation 2007. All rights reserved

Part # CAT-DLS Revised April 2007

Courtesy of Steven Engineering, Inc - (800) 258-9200 - sales@steveneng.com - www.stevenengineering.com