



This data sheet interacts with
PRT2 Catalogue
Pages 50-51



This data sheet interacts with
DTS Catalogue

DTS+ Driven Track System

The HepcoMotion DTS product family has been expanded to cater for a wider range of applications and now includes the DTS+.

The DTS+ system incorporates key features of Hepco's PRT track system and original DTS, combining them with a high load capacity connection for carriages to the drive belt. The carriages will not disengage from the belt, allowing transmission of higher forces compared to the original DTS system.

Whilst the original DTS will often continue to be the right choice for many applications, the DTS+ may be of particular interest in applications with high loads, a vertical orientation, or where the free space inside the track circuit is required to integrate additional equipment.

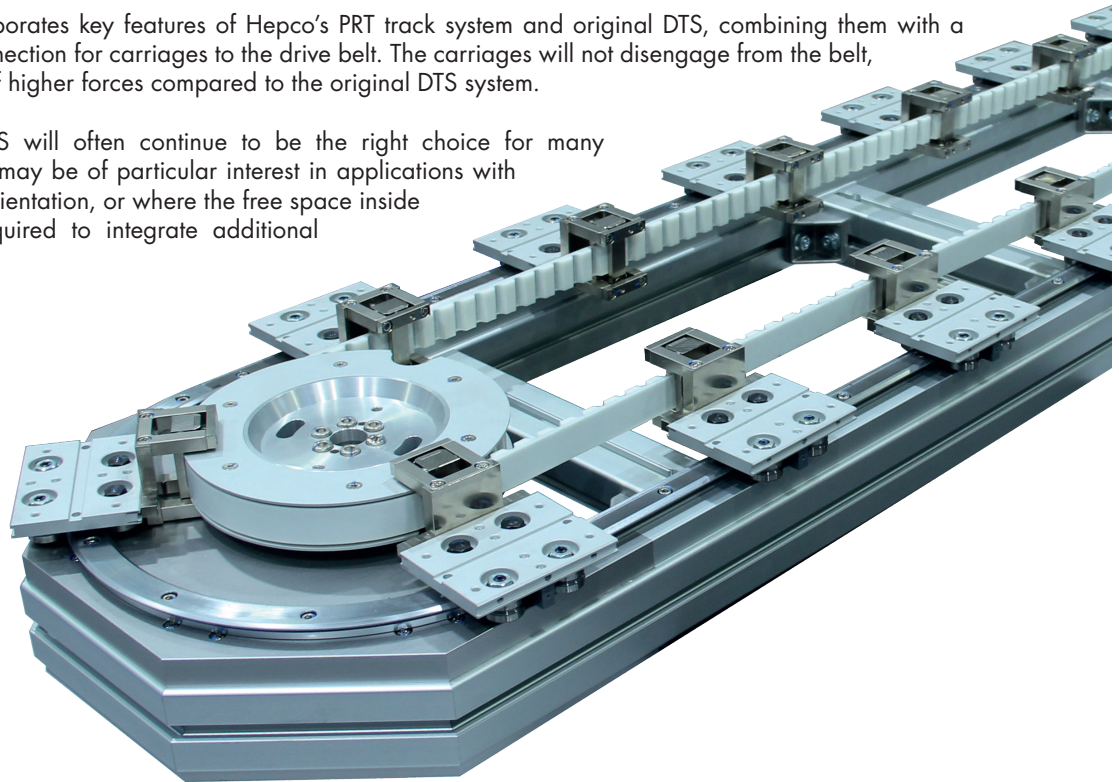

Construction of the DTS+

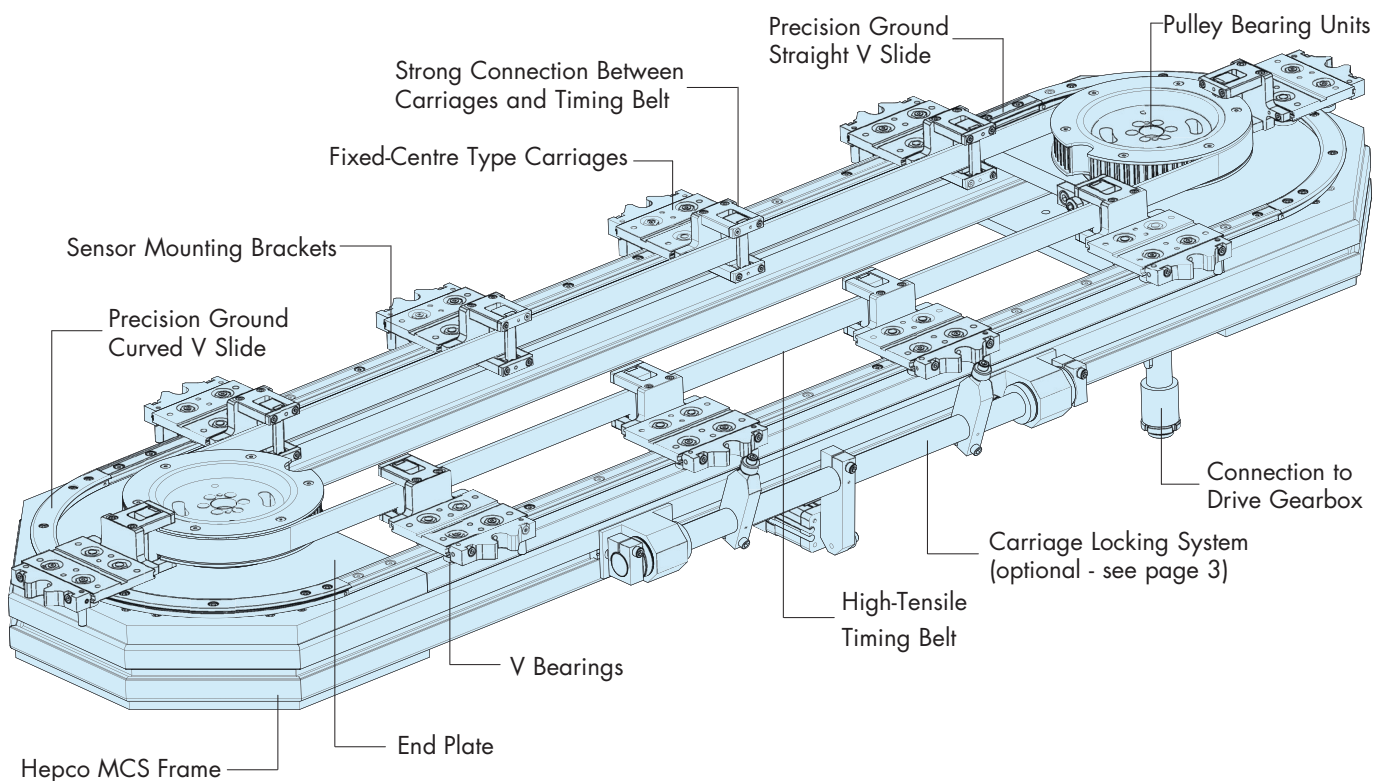

DTS+ System Dimensions

The layout of the DTS+ system is adapted to suit customers' individual application requirements. As it is not practical to detail every dimension within the range, key dimensions are provided in this datasheet. For more information or advice on system suitability for a particular application, please contact Hepeco's Technical Department. An approval drawing will be created for every design ordered.

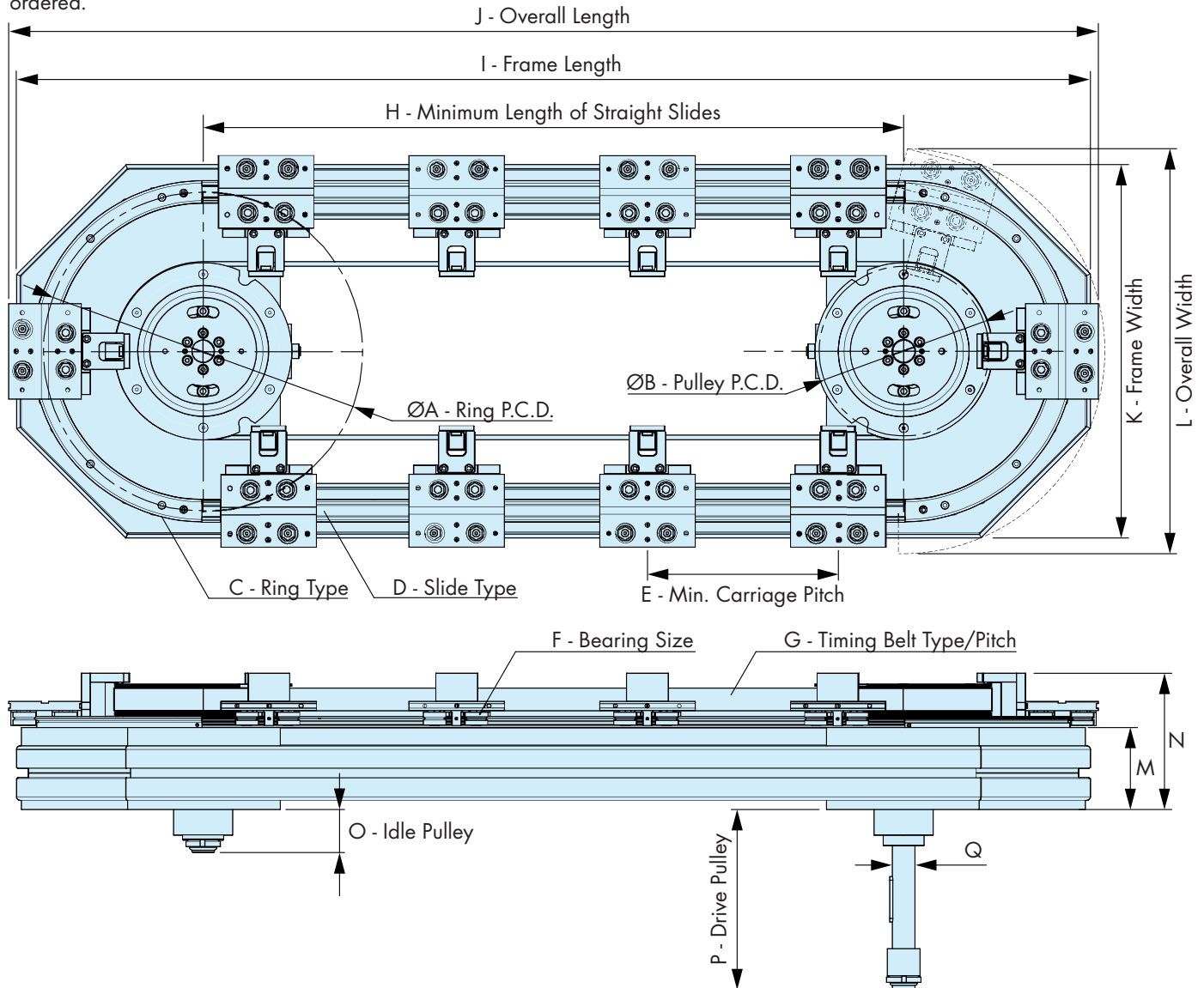

A system with 180° ring segments in an oval circuit is shown above. Rectangular systems with 90° segments are also available.

System Size	ØA (Ring PCD)	ØB*1 (Pulley PCD Options)			C	D	E	F	G	H
25-351	351	190.9	200.5	210.1	TR25-351	TNS25	110	Ø25	25AT10	250
44-468	468	216.4	235.5	256.6	TR44-468	TNM44	160	Ø34	25AT20	300
44-612	612	381.9	420.2	445.6	TR44-612	TNM44	200	Ø34	32AT20	500
76-799	The 76-799 system is in development: details will be released at a later date.									

System Size	I	J*2	K*3	L*2,3	M	N	O	P	Q*4	
25-351	H + 408	H + 428	411	440	90	150	48	198.5	25	
44-468	H + 523	H + 578	596	583	90	150	48	198.5	25	
44-612	H + 667	H + 722	740	727	90	150	48	198.5	25	
76-799	The 76-799 system is in development: details will be released at a later date.									

1. Pulley size is determined by carriage pitch and will be confirmed on specification of a system. Refer to page 4 for a list of carriage pitches.
2. Dimensions J and L are for a system without Carriage Locking. Please refer to page 9 of the DTS catalogue for locking system dimensions.
3. Dimensions K and L relate to Oval format systems only.
4. The drive shaft assembly on the 76-799 system will be designed to suit the customer's motor. Please discuss this requirement with our team.

DTS+ Carriage Assembly Dimensions

Typical carriage assembly information is given below. Carriages are supplied as standard with four customer mounting holes 'E' on a C x D pattern.

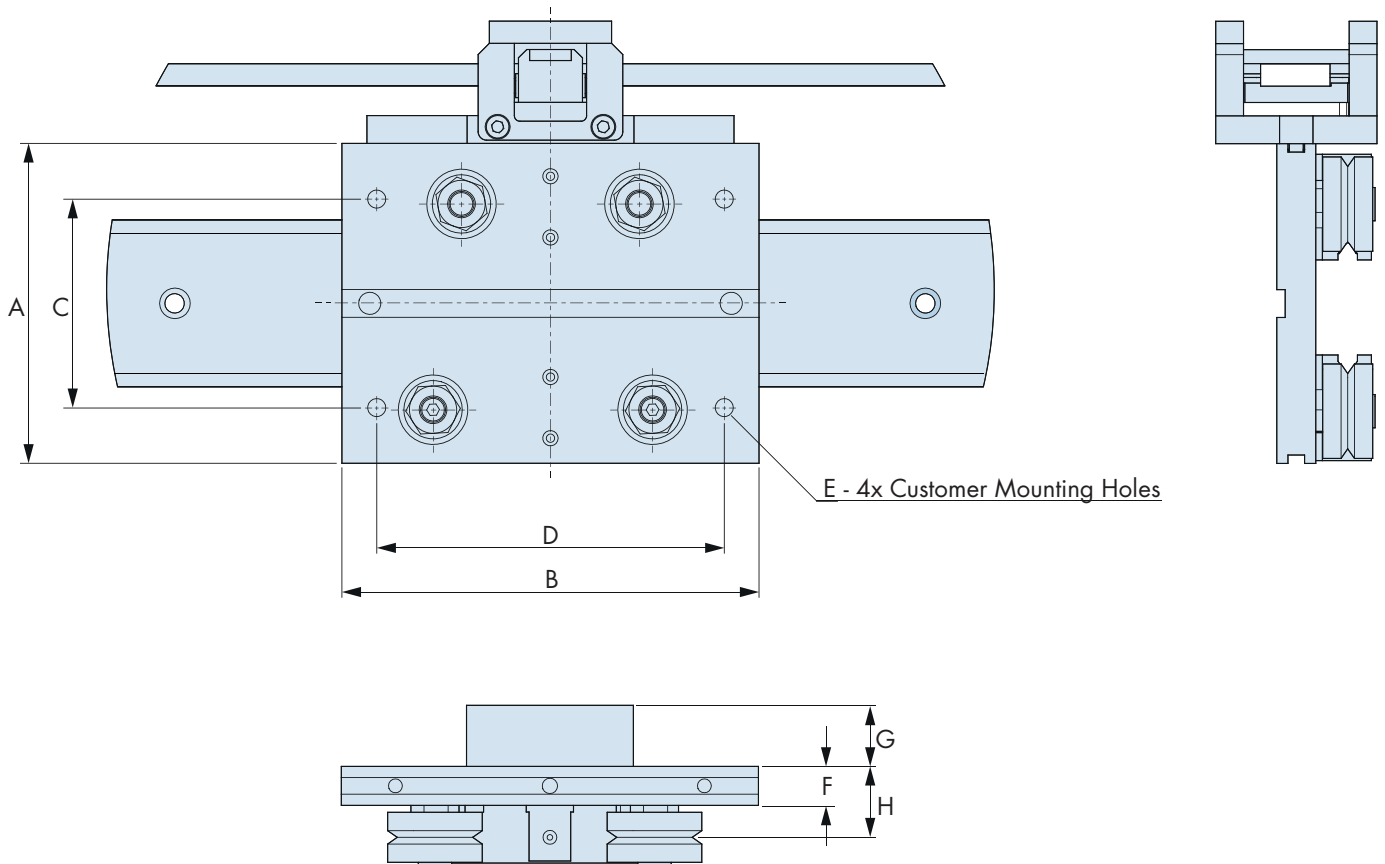

System Size	A	B	C x D	E	F	G	H
25-351	80	105	50 x 85	M6 x 1	10	31	19
44-468	115	150	75 x 125	M8 x 1.25	14	22	25.5
44-612	115	150	75 x 125	M8 x 1.25	14	22	25.5
76-799	The 76-799 system is in development: details will be released at a later date.						

Note: The table above lists the standard dimensions for each system size. Whilst some dimensions of the belt-fixing mechanism change depending on the size of pulley required to fulfil the system specification, the fixed dimensions are given above. An approval drawing for every system ordered will be produced prior to manufacture.

Carriage Locking System (Option for intermittent motion)

The carriage locking system aligns specific carriages to a repeatable position, anywhere along any straight section of the circuit to $\pm 0.05\text{mm}$. The slight compliance of the belt allows each carriage to be guided to its exact stop position by a cam roller. Please specify the stations on the track system where you require carriages to be locked in position.

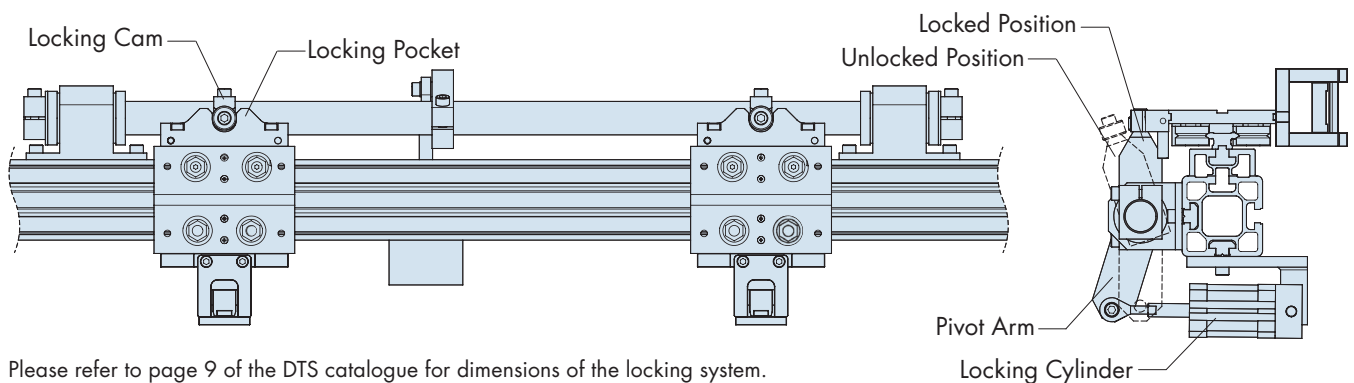

Please refer to page 9 of the DTS catalogue for dimensions of the locking system.

DTS+ Carriage Pitch Intervals & Compatible System Sizes

The method of construction of the DTS+ means pulley size is determined by the pitch between carriages on the system. A series of pockets in the pulleys house the belt connection as carriages travel around the curve. The number of pockets in the pulley is dictated by the relationship between pulley circumference and carriage pitch. Consequently, the carriage pitch intervals that can be achieved are finite. A list of possible carriage pitches is given below, up to 1500mm. In some instances, it may be possible to accommodate a carriage pitch outside the range shown below. For carriage pitches above 1500mm, or those not shown in the list below, please contact our Technical Sales team to discuss your application requirements.

Pitch	25-351	44-468	44-612	76-799	Pitch	25-351	44-468	44-612	76-799
110	✓				750	✓			
120	✓				770	✓			
140	✓				780				✓
150	✓				800	✓	✓	✓	✓
160		✓			810	✓			
180	✓				840	✓		✓	✓
200	✓	✓	✓	✓	880	✓	✓	✓	
210	✓				900	✓	✓	✓	✓
220	✓		✓		910	✓			
240	✓	✓	✓	✓	960	✓	✓	✓	✓
260				✓	980	✓		✓	
270	✓				990	✓			
280	✓		✓		1000	✓	✓	✓	✓
300	✓	✓	✓		1020		✓		
320		✓		✓	1040		✓		✓
330	✓				1050	✓			
340		✓			1080	✓		✓	✓
350	✓				1100	✓	✓	✓	
360	✓		✓	✓	1120	✓	✓	✓	✓
390					1140				
400	✓	✓	✓	✓	1170	✓			
420	✓		✓		1190	✓			
440	✓		✓		1200	✓	✓	✓	✓
450	✓				1210	✓			
480	✓	✓	✓	✓	1260	✓		✓	✓
490	✓				1280		✓		✓
500	✓	✓	✓		1300	✓	✓	✓	✓
520				✓	1320	✓		✓	✓
540	✓			✓	1330	✓			
550	✓				1350	✓			
560	✓	✓	✓		1360		✓		
600	✓	✓	✓	✓	1380				
630	✓				1400	✓	✓	✓	✓
640		✓		✓	1430	✓			
660	✓		✓		1440	✓	✓	✓	✓
680		✓			1470	✓			
700	✓	✓	✓		1480		✓		
720	✓	✓	✓	✓	1500	✓	✓	✓	
740		✓			Please consult our Technical Sales team for carriage pitches above 1500mm.				

DTS+ Load Capacity

Thanks to the specially designed belt-fixing mechanism, the DTS+ system can accommodate increased driving forces. This makes the DTS+ ideal for continuous and intermittent motion applications where loads exceed those that can be accommodated by the original DTS system, or the carriage pitch cannot be met with DTS2.

In the original DTS system, a feature is engineered into the design to disengage the carriage from the drive belt in the event of an overload. This prevents damage to the belt connections, which can be costly and time-consuming to replace, but limits the loads that can be transmitted. The superior drive strength of the DTS+ means carriages will not disengage from the drive belt. As such, it is recommended to have a mechanical or software torque limiter in the drive system to avoid mechanical failure in the event of a blockage in the system.

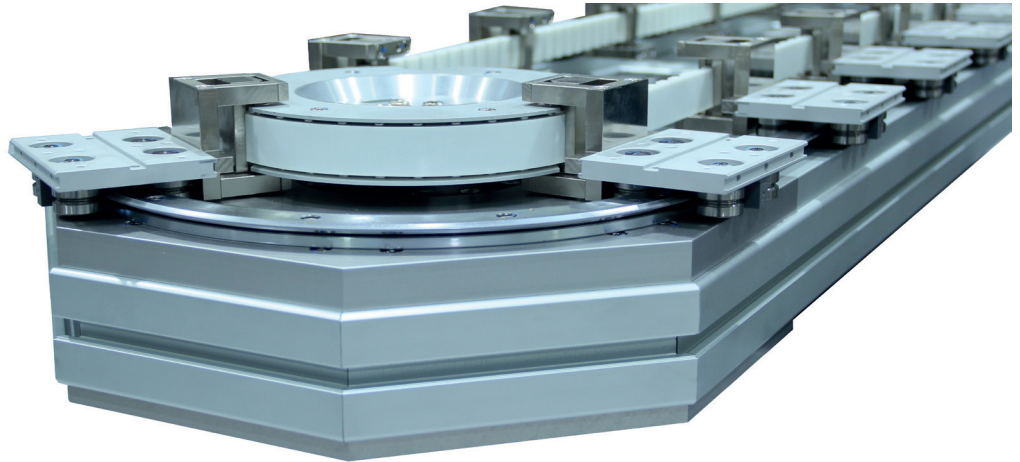

There is no fundamental limit to the number of carriages that can be used in a configuration, but the loads applied to the belt and belt connection will be the factor which determines the most appropriate system size for an application. The linear speed and rate of acceleration will affect the load on the belt connections and torque through the drive assembly.

As carriages travel faster through the curves than on the straights, they experience acceleration and deceleration in the transition between straight and curve. This means that, for any given mass on a carriage, there is a maximum straight speed that can be achieved. In typical operation, the peak load on the belt connection should not exceed 250N for a size 25 system or 500N for a size 44. In some applications it may be possible to exceed this working load; the maximum load on any belt connection must not exceed 500N for a size 25 system or 1000N for a size 44 system. Load capacity information for the 76-799 system will be confirmed at a later date.

The graph below can be used as a quick guide to DTS+ performance in terms of linear speed and carriage mass. If the application you are specifying sits below the curve for that system size, it is likely to be within the capacity of that system. The curves relate to a horizontally mounted system and are given as an approximate guide only. Please contact our Technical Sales team to discuss feasibility of systems with linear speeds in excess of 1.5m/s or those mounted in a vertical orientation.

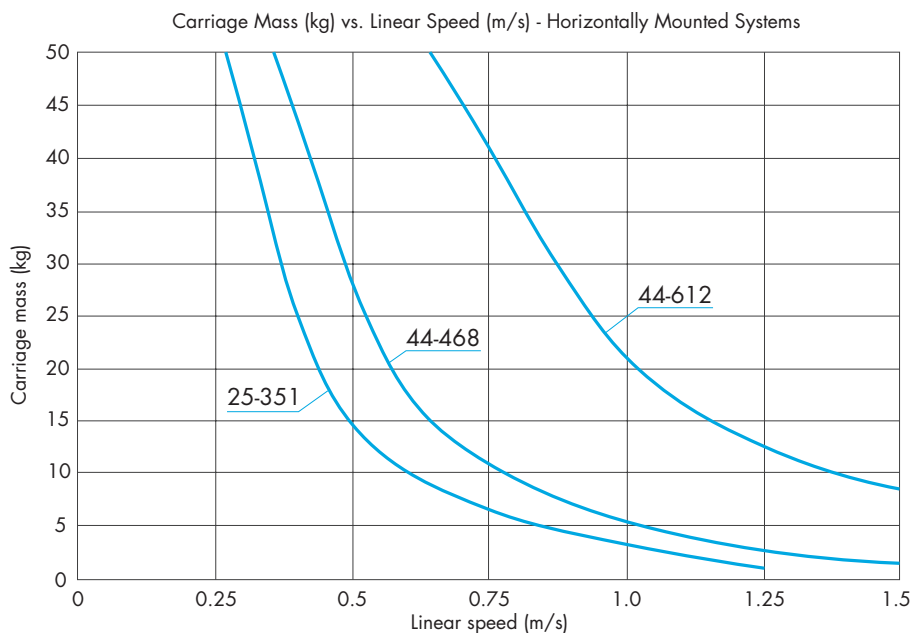

To confirm system specification and suitability, please speak with one of our Technical Sales team, who will discuss the requirements and parameters of your application to determine the most suitable system specification.

DTS+ Application Examples

The following pages illustrate example applications for the DTS+ system.

In continuous motion applications, the predictable path and high stiffness of the DTS+ track system means accurate tasks can be performed while moving, in precise registration with other mechanisms. Performing tasks on the move can enable processes to be carried out at a higher rate.

A great advantage of the DTS product family is the ability to be programmed to stop at any position or number of positions around the circuit. In systems with intermittent motion, a key requirement is reliable product positioning with stability for operations and processes during both the stationary and moving portions of the motion cycle. The DTS+ is an obvious choice in preference to friction-driven pallet systems, which are slow and complex.

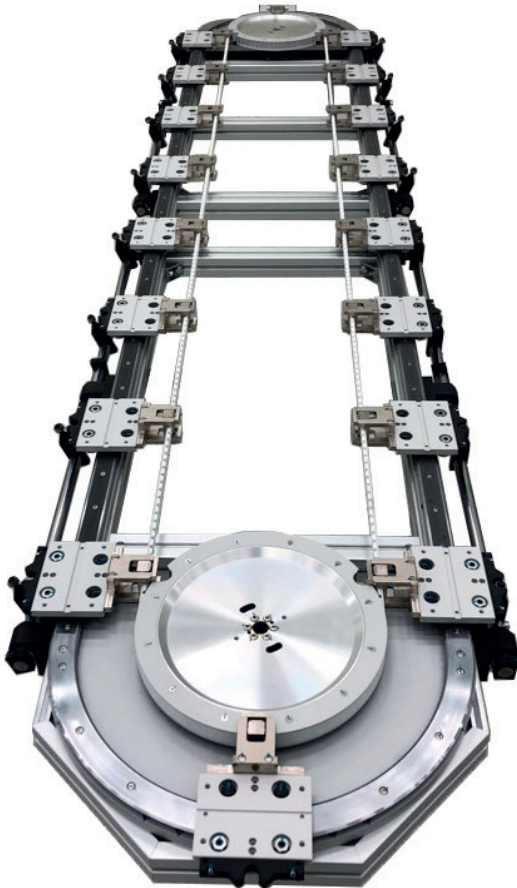

44-612 Oval

This system has a carriage pitch of 400mm. It has 18 carriages and is driven by 60-tooth AT20 profile pulleys.

This system includes a carriage locking system which, when activated, maintains a position accuracy of locked carriages within $\pm 0.05\text{mm}$.

Payload per carriage = 7kg.
Carriage pitch = 400mm.
Index distance = 400mm.

System speed = 1m/s.
Acceleration = 2.5m/s^2 .

76-799 Oval

This system has 36 carriages at a pitch of 240mm. It is driven by 72-tooth AT20 profile pulleys.

This system also includes a carriage locking system. A locking cam is fitted to the outside of each carriage plate.

The carriage locking system is ideally suited to indexing applications, where repeated positional accuracy of the carriage is required.

Payload per carriage = 35kg.
Carriage pitch = 240mm.
Index distance = 960mm.

System speed = 0.63m/s.
Acceleration = 1.2m/s^2 .

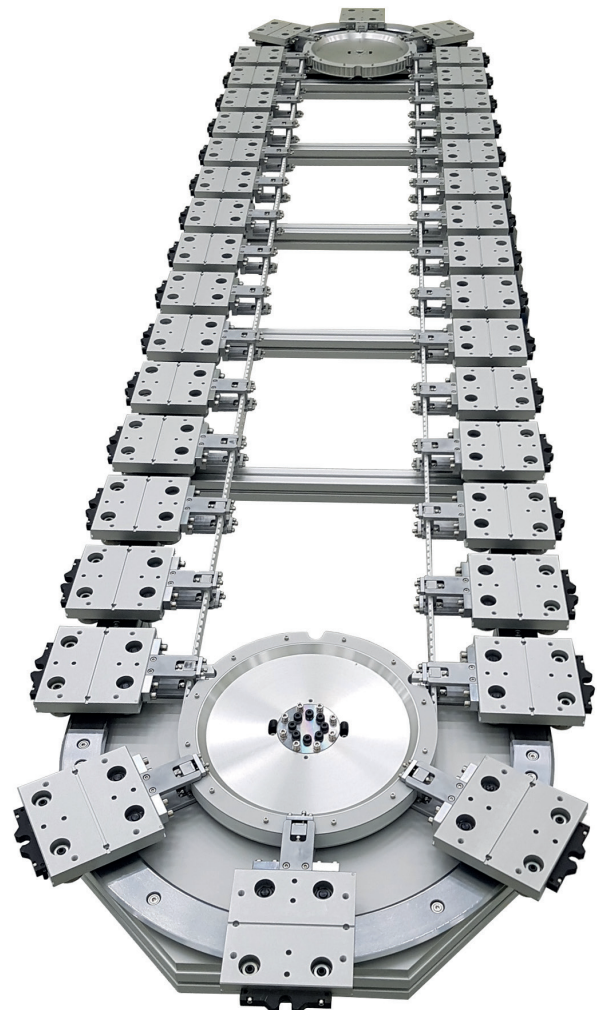

DTS+ Driven Track System

76-799 Rectangle

This rectangular system has 8 carriages at a pitch of 780mm. It is driven around four 78-tooth AT20 profile pulleys.

The space inside the track system allows internal access and space to fit customer components.

Payload per carriage = 50kg.
Carriage pitch = 780mm.
Index distance = 780mm.

Index speed = 0.98 m/s.
Acceleration = 2.4 m/s².

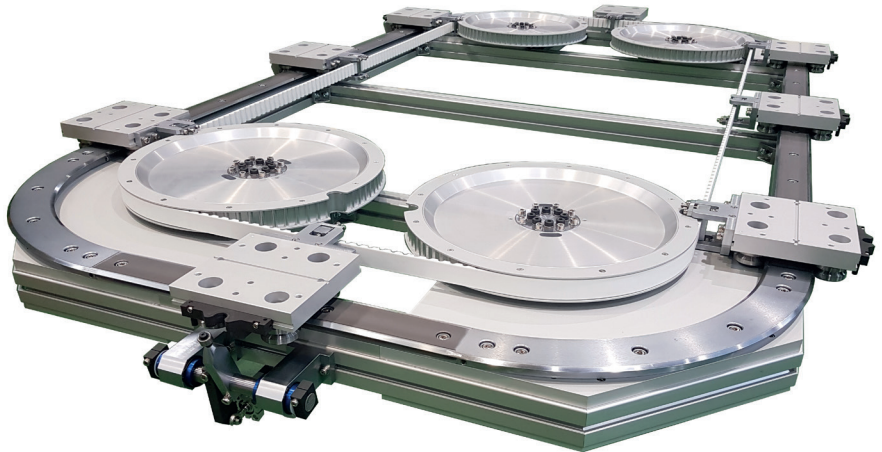

44-612 Oval

Two systems working in parallel

This system uses two DTS systems which run in parallel. Each DTS system has four carriages with a pitch of 1320mm. The carriages are driven by a 66-tooth AT20 profile pulley, the drive pulleys are connected with a connection shaft and driven by a single motor.

Load shared by each pair of carriages = 50kg.
Carriage pitch = 1320mm.

System speed = 0.6m/s.
Acceleration = 0.6 m/s².

Ordering Example

DTS+ 44-612 R 8 x 480

Product range: DTS+

System size: **25-351**, **44-468**, **44-612** or **76-799**.

Leave blank for an Oval system.

R indicates a Rectangular system.

Distance between carriages (mm).

Total number of carriages on system.

HepcoMotion®

Lower Moor Business Park,
Tiverton Way, Tiverton,
Devon, England EX16 6TG

Tel: +44 (0) 1884 257000

Fax: +44 (0) 1884 243500

E-mail: sales@hepcotion.com

Catalogue No. DTS+ 01 UK © 2020 Hepco Slide Systems Ltd.

Reproduction in whole or part without prior authorisation from Hepco is prohibited. Although every effort has been made to ensure the accuracy of the information in this datasheet, Hepco cannot accept liability for any omissions or errors. Hepco reserves the right to make alterations to the product resulting from technical developments.

Many Hepco products are protected by: Patents, Copyright, Design Right or Registered Design. Infringement is strictly prohibited and may be challenged in law.

The Customer's attention is drawn to the following clause in Hepco's conditions of sale:

'It shall be the Customer's sole responsibility to ensure that goods supplied by Hepco will be suitable or fit for any particular application or purpose of the Customer, whether or not such application or purpose is known to Hepco. The Customer will be solely responsible for any errors in, or omission from, any specifications or information the Customer provides. Hepco will not be obliged to verify whether any such specifications or information are correct or sufficient for any application or purpose.'

Hepco's full conditions of sale are available on request and will apply to all quotations and contracts for the supply of items detailed in this datasheet.

HepcoMotion is the trading name of Hepco Slide Systems Ltd.

HepcoMotion.com