

**Service Interval Calculations**

After extended service, slight play in the carriage may develop. This can be corrected by readjusting the carriage. Adjustment is quick and simple and may be repeated. Adjustment instructions will be supplied with units.

Please consult the table below for maximum carriage loading and service interval calculation. Bishop-Wisecarver will provide additional data and calculations for your application on request.

Carriage Load Capacity				
L <sub>1</sub>	L <sub>2</sub>	M <sub>S</sub>	M <sub>V</sub>	M
500N	500N	5Nm	14Nm	14Nm

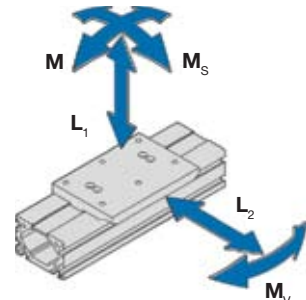

To determine service interval, first calculate the load factor LF using this equation.

$$L_F = \frac{L_1}{L_{1(max)}} + \frac{L_2}{L_{2(max)}} + \frac{M_S}{M_{S(max)}} + \frac{M_V}{M_{V(max)}} + \frac{M}{M_{(max)}} \leq 1$$

$$\text{Service Interval(km)} = \frac{2500}{(0.1+0.9 L_p)}$$

Note: Life will be several times this interval.

\*Note that stroke length is 175mm shorter.

\*\*Units with plain beams will be supplied with 4xM5 tapped holes in pattern "A" (see inside) unless alternative mounting is specified.

**Main Unit**

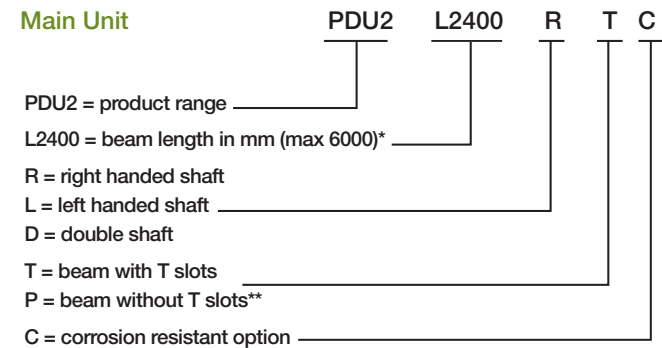

**Technical Specifications**

Parameter			
Pulley radius	r	(cm)	1.53
Max linear force	F <sub>max</sub>	(N)	280
Linear move/shaft rev		(mm)	96
Weight of whole T slot beam unit		(kg)	0.0022xL+1.4
Weight of whole plain beam unit		(kg)	0.0035xL+1.4
Mass of carriage	M <sub>c</sub>	(kg)	0.48
Mass of belt	M <sub>b</sub>	(kg/m)	0.046
Drive efficiency	ηΔ	(-)	0.9
Break away friction	F <sub>ba</sub>	(N)	8N
Coefficient of friction	μ	(-)	0.02
Moment of inertia of pulley	I <sub>p</sub>	(kgcm <sup>2</sup> )	0.14
T slot beam moment of inertia	I <sub>x-x</sub>	(mm <sup>4</sup> )	1.6 x 10 <sup>5</sup>
T slot beam moment of inertia	I <sub>y-y</sub>	(mm <sup>4</sup> )	3.5 x 10 <sup>5</sup>
Plain beam moment of inertia	I <sub>x-x</sub>	(mm <sup>4</sup> )	2.2 x 10 <sup>5</sup>
Plain beam moment of inertia	I <sub>y-y</sub>	(mm <sup>4</sup> )	5.8 x 10 <sup>5</sup>
Bumper impact energy		J/impact	3

**Bishop-Wisecarver Corporation:** Manufacturer of the original DualVee® guide wheel and industry leader in guided motion technology, and exclusive North and Central American partner and distributor for HepcoMotion products since 1984.

**BISHOPWISECARVER®**

**Bishop-Wisecarver**

- DualVee® Guide Wheels
- LoPro® Linear Motion System
- MinVee® Linear Slide System
- QuickTrak® Linear Motion System
- SRX-150 Linear Motion System
- UtiliTrak® Linear Motion Guide



**HepcoMotion®**

- DAPDU2 Double Acting Profile Driven Unit
- DLS Driven Linear System
- DTS Driven Track System
- GV3 Linear Guidance and Transmission System
- HDCB Heavy Duty Compact Beam
- HDCS Heavy Duty Compact Screw
- HDLS Heavy Duty Driven Linear System
- HDRT Heavy Duty Ring Slides and Track System
- HDS Heavy Duty Slide System
- MHD Heavy Duty Track Roller Guidance System
- MCS Machine Construction System
- PDU2 Profile Driven Unit
- PRT Precision Ring and Track System
- PSD120 Profile Screw Driven Unit
- SBD Sealed Belt Drive
- Simple-Select®
- SL2 Stainless Steel Based Slide System

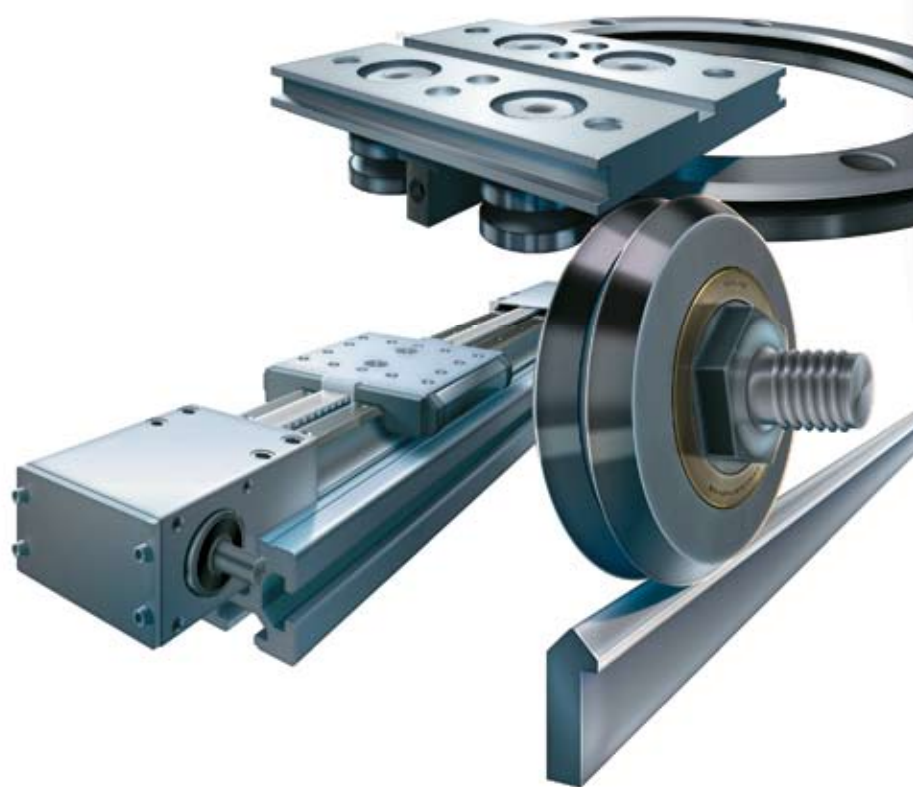

**HepcoMotion®**  
**PDU2**  
**Profile Driven Unit**  
Compact Linear Transmission

888.580.8272 www.bwc.com **BISHOPWISECARVER®**

© Bishop-Wisecarver Corporation 2007. All rights reserved.

Part # CAT-PDU2 Revised June 2007

Courtesy of Steven Engineering, Inc - (800) 258-9200 - sales@steveneng.com - www.stevenengineering.com



# HepcoMotion® Profile Driven Unit

## PDU2 Compact Linear Transmission

The PDU2 linear transmission unit delivers high performance at low development costs for applications such as food and pharmaceutical packaging. The belt driven units are manufactured to customer's individual length requirements and have a short turn around time.

HepcoMotion patented wheel technology enables the PDU2 to surpass other similar sized units by offering a load capacity of 500N and speeds up to 6m/s. This advanced engineering allows the unit's wheels to run virtually friction-free on the inside surface of the profile without lubrication maintenance. The carriage plate of the PDU2 is designed to accommodate the mounting of a second unit and Bishop-Wisecarver also offers a full range of options, such as motors, limit switches and MCS aluminum frame systems.

Bishop-Wisecarver provides effective linear motion products for all manufacturing and technical applications. Please contact our product engineers or visit [www.bwc.com](http://www.bwc.com) for 2D and 3D CAD files. Our technical staff is available to assist with information specific to your application.

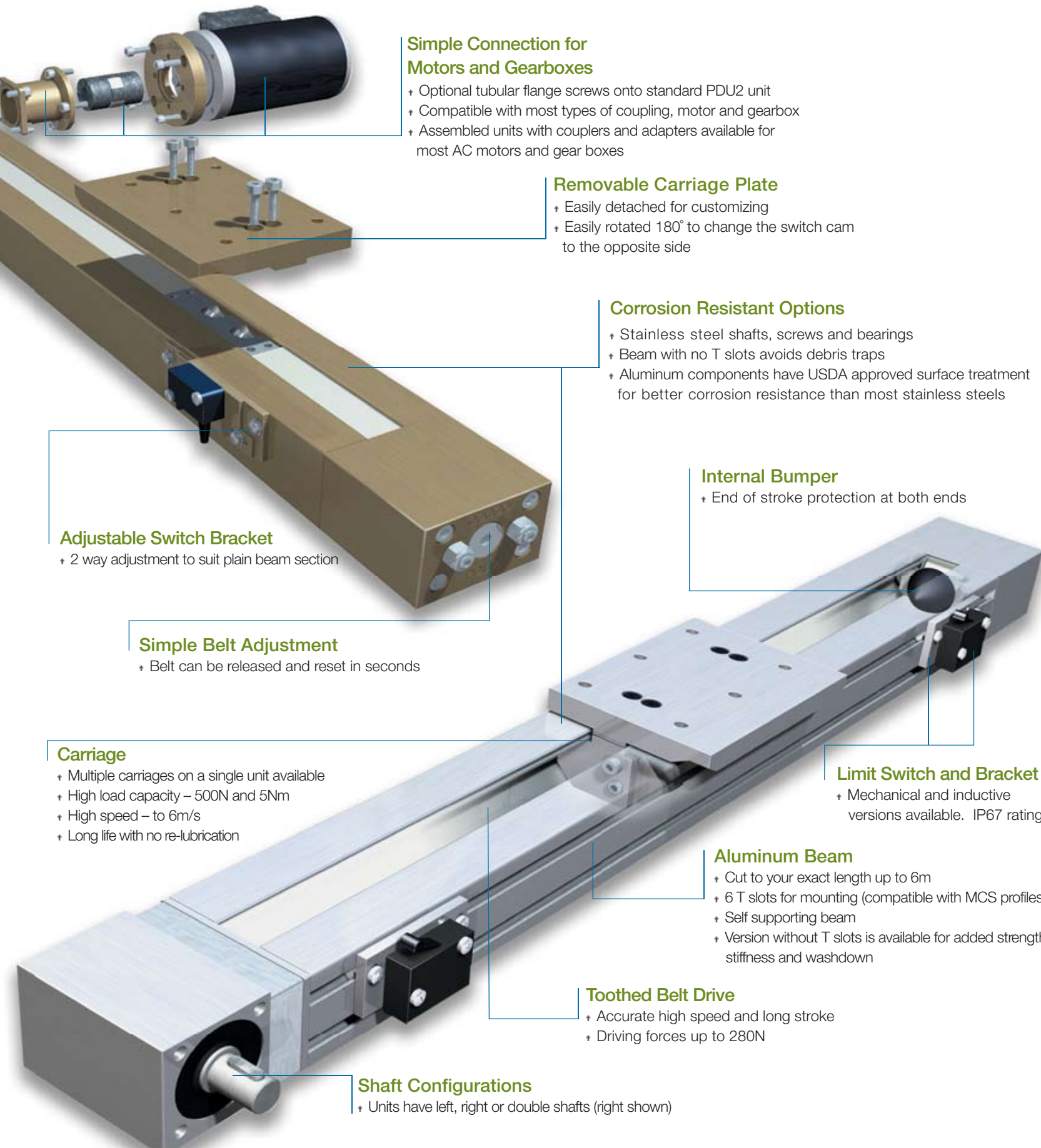

### Simple Connection for Motors and Gearboxes

- Optional tubular flange screws onto standard PDU2 unit
- Compatible with most types of coupling, motor and gearbox
- Assembled units with couplers and adapters available for most AC motors and gear boxes

### Removable Carriage Plate

- Easily detached for customizing
- Easily rotated 180° to change the switch cam to the opposite side

### Corrosion Resistant Options

- Stainless steel shafts, screws and bearings
- Beam with no T slots avoids debris traps
- Aluminum components have USDA approved surface treatment for better corrosion resistance than most stainless steels

### Internal Bumper

- End of stroke protection at both ends

### Adjustable Switch Bracket

- 2 way adjustment to suit plain beam section

### Simple Belt Adjustment

- Belt can be released and reset in seconds

### Carriage

- Multiple carriages on a single unit available
- High load capacity – 500N and 5Nm
- High speed – to 6m/s
- Long life with no re-lubrication

### Limit Switch and Bracket

- Mechanical and inductive versions available. IP67 rating

### Aluminum Beam

- Cut to your exact length up to 6m
- 6 T slots for mounting (compatible with MCS profiles)
- Self supporting beam
- Version without T slots is available for added strength, stiffness and washdown

### Toothed Belt Drive

- Accurate high speed and long stroke
- Driving forces up to 280N

### Shaft Configurations

- Units have left, right or double shafts (right shown)

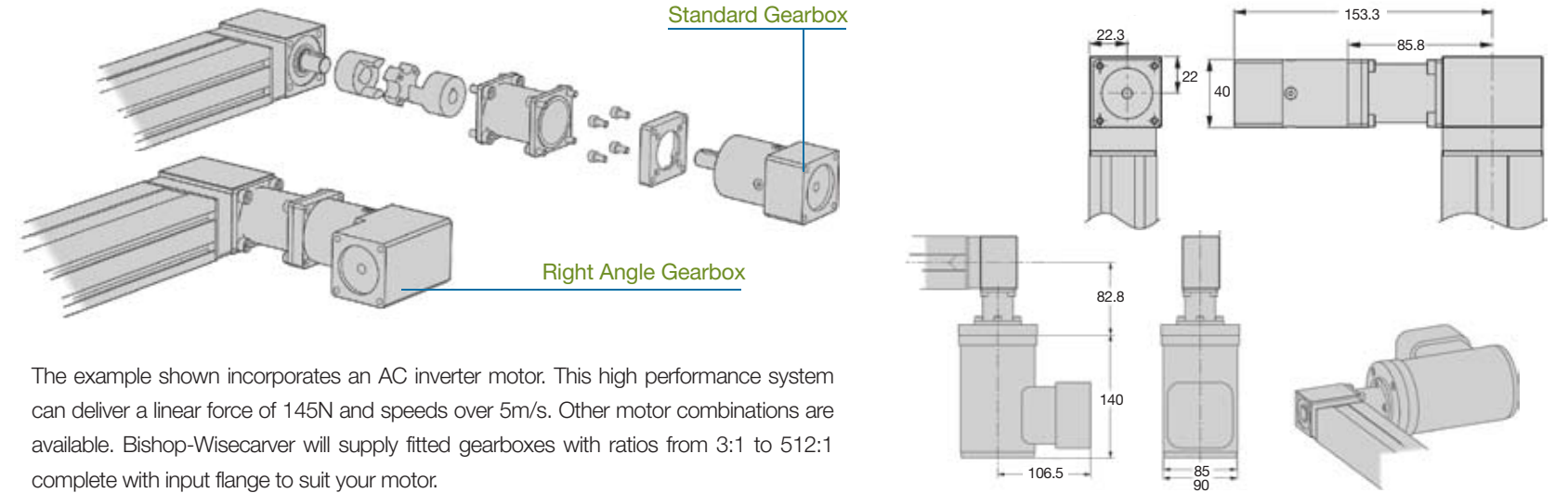

The example shown incorporates an AC inverter motor. This high performance system can deliver a linear force of 145N and speeds over 5m/s. Other motor combinations are available. Bishop-Wisecarver will supply fitted gearboxes with ratios from 3:1 to 512:1 complete with input flange to suit your motor.

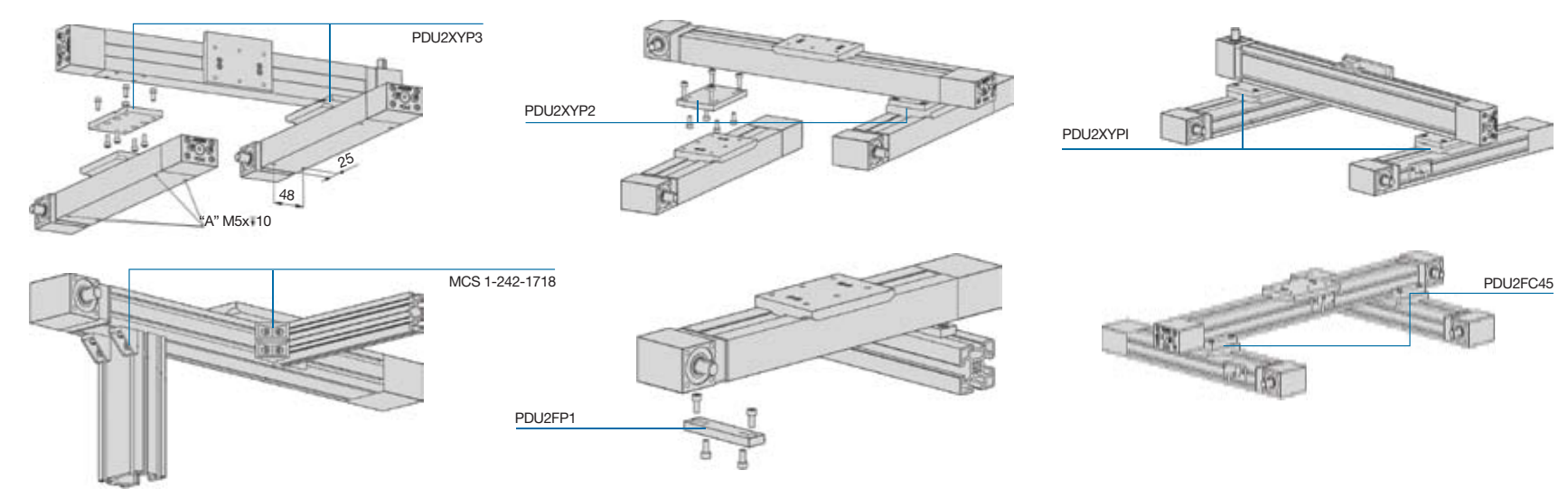

### Dimensions

The main dimensions of the PDU2 are shown in the drawing below. For additional details, please contact Bishop-Wisecarver or visit [www.bwc.com](http://www.bwc.com) for 2D and 3D CAD files.

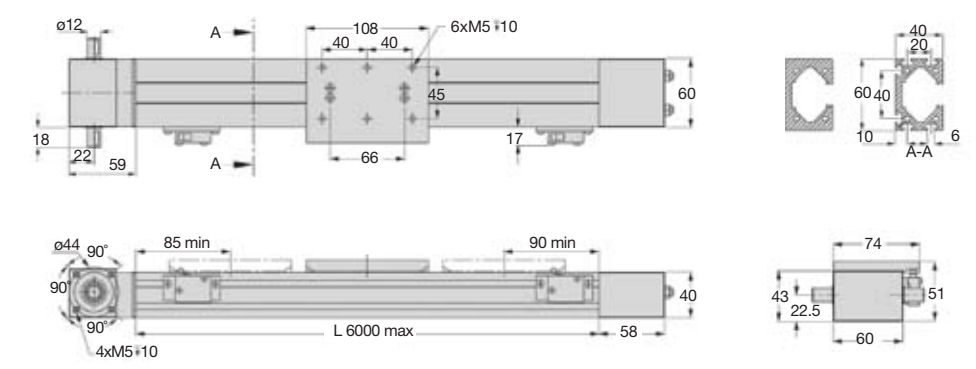

### Ancillary Components

Limit switch assembly (includes switch, bracket & fixings) = PDU-V3SWA-M (mechanical), PDU-V3SWA-I (inductive).



### Drive Connections

The PDU2 can be supplied with a motor or gearbox.

Connection kits are available in a wide range of motor faces including IEC C80, C90, C105 and NEMA 23 and 34 are readily available. Bishop-Wisecarver can also manufacture the components required to fit customers' specific motors and gearboxes.

Bishop-Wisecarver can supply assorted motors, optional holding brakes, encoders for positioning and inverter drives for power and control.

### Axis Connections

The PDU2 allows easy connections between axes, MCS frames and other machine components.

The configurations shown include part numbers for various brackets.

Please note that tapped holes are required to suit the specific axis connection brackets for plain beam versions, mounting brackets\* and limit switch brackets.

The PDU2 will normally be supplied with these holes already inserted.

\*Note: Plain beam versions will be supplied with default "A" pattern mounting holes in positions.