

UtiliTrak[®] Series



**A LINEAR
GUIDE SYSTEM**

EXPERTLY DESIGNED, DELIVERED TO PERFORM

Powered by nearly 70 years of relentless problem-solving and steadfast reliability, Bishop-Wisecarver delivers innovative motion solutions around the world that thrive in harsh and extreme conditions. Our linear and rotary motion solutions, custom complex assemblies, and embedded intelligence systems lead the manufacturing industry, and they are backed by The Signature Experience promise of expert guidance, confidence and customer satisfaction.

PERFECT FOR HARSH AND EXTREME ENVIRONMENTS

When you purchase from Bishop-Wisecarver, you aren't just getting a product that works; you're getting products, systems, and industry-leading expertise you can trust, especially in harsh conditions and critical environments—always exceeding our customers' reliability requirements.

Our Motion Products and Solutions Are Also Perfect For:



**HARSH
ENVIRONMENTS**



LONG LENGTH



LOW NOISE



**HIGH/LOW
TEMPERATURE**



**LOW TOTAL COST
OF OWNERSHIP**



**SMOOTH, LOW
FRICTION MOTION**



**MOIST
ENVIRONMENTS**



FOOD GRADE



CLEAN ROOM



VACUUM

INTRODUCTION

UtiliTrak® linear guides are designed for commercial applications where easy installation and minimal maintenance requirements are the primary design objectives. It is constructed with DualVee Motion Technology® in the vee and vee/crown wheel, or the MadeWell® crown roller designs. These, along with a variety of material and seal options, provides high reliability, easy installation and low maintenance solutions in a sleek, compact design.

Fit up is pre-set for PW, SW, and CR wheel plates when ordered with matching linear guide tracks, but is easily adjusted by rotating the eccentrically mounted center guide wheels. This allows modification of running characteristics such as drag, breakaway force and preload. The VC series wheel plates are not pre-set.

Each wheel plate assembly includes a standard channel lubricator, which distributes a light coat of oil along the length of the channel during normal operation. Channels can be butt-joined for unlimited travel lengths.

Design Benefits

- Very low rolling friction
- Ground channel butt-joint
- Butt-joining precision ground channel for unlimited travel lengths
- High load capacity
- Contamination tolerant
- Low maintenance
- Simple installation
- Vibration-resistant options **NEW**

Key Industries

- Architecture
- Automotive
- Medical
- Packaging
- Printing
- Pharmaceutical

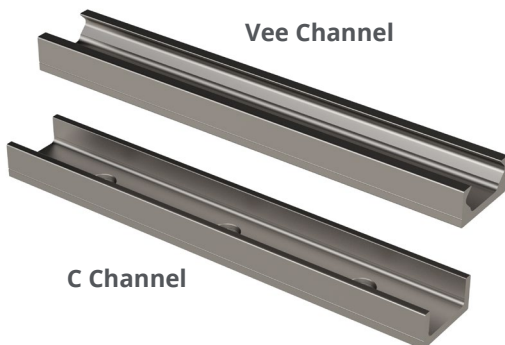

PW Series

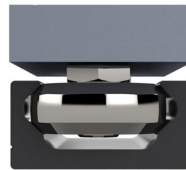

VC Series



SW Series



CR Series

TABLE OF CONTENTS

UtiliTrak Overview	3 - 5
PW Series	6 - 10
SW Series	11 - 16
VC Series	17 - 21
CR Series	22 - 25
Accessories	26 - 31

For instructions regarding mounting and orientation, life estimation, pre-loading, and maintenance, see the UtiliTrak section of the Technical Data catalog.

Need Help

Application + Design Assistance

925.439.8272

3D Modeling + CAD Drawing

BWC.com

UTILITRAK® SERIES COMPARISON

		PW SERIES		VC SERIES	SW SERIES		CR SERIES
		CROWN	90° VEE	90° VEE/CROWN	CROWN	90° VEE	90° VEE
OVERVIEW	<i>Compatible Channel</i>	C Channel	90° Vee	90° Vee C Channel	C Channel	90° Vee	90° Vee
	<i>Compatible Wheel Plate</i>	Crown Roller	90° Vee	90° Vee/Crown	Crown Roller	90° Vee	90° Vee
	<i>Loading Direction</i>	Radial Only	Axial and Radial	Vee = Axial and Radial Crown = Radial Only	Radial Only	Axial and Radial	Axial and Radial
	<i>Optional Brake</i>	Yes	Yes	Yes	Yes	Yes	Not Available
	<i>Available Sizes</i>	0, 1, 2	0, 1, 2	1, 2, 3	1, 2, 3	1, 2, 3	1, 2, 3
CHANNEL	<i>Material(s)</i>	Aluminum	Aluminum	Carbon Steel	Carbon Steel	Carbon Steel	Stainless Steel and Aluminum
	<i>Standard Coating</i>	Clear Anodize	Clear Anodize	Polyurethane Paint	Polyurethane Paint	Polyurethane Paint	Clear Anodize
	<i>Hardened</i>	No	No	Yes	Yes	Yes	Yes
	<i>Finish</i>	Extruded	Extruded	Precision Ground	Precision Ground	Precision Ground	Polished
WHEEL PLATE	<i># of Wheels</i>	3, 4, 5	3, 4, 5	3, 4, 5	3, 4, 5	3, 4, 5	3
	<i>Bearings</i>	Single Row Deep Groove	Single Row Deep Groove	Double Row Angular Contact	Double Row Angular Contact	Double Row Angular Contact	Double Row Angular Contact
	<i>Wheel Material</i>	Polymer Overmold Stainless Steel	Polymer Overmold Stainless Steel	Carbon Steel	Carbon Steel	Carbon Steel Stainless Steel	Stainless Steel
	<i>Wheel Material Grade</i>	Polyacetal and 440C	Polyacetal and 440C	52100	52100	52100 440C	440C
	<i>Max. Angular Misalignment</i>	+/- 7°	0°	+/- 2°	+/- 7°	0°	0°
	<i>Vibration-Resistant Lock Nut</i>	Optional	Optional	Optional	Optional	Optional	Not Available
	<i>Wheel Bottom Hex Feature (Size 2 and 3)</i>	Standard	Standard	Not Available	Standard	Optional	Not Available
	<i>Preloaded Adjustment Hex</i>	Metric	Metric	Metric	Metric	Inch	Metric
	<i>Lubrications</i>	Molded Nylon End Caps	Molded Nylon End Caps	Molded Nylon End Caps	Molded Nylon End Caps	Molded Nylon End Caps	Stamped Stainless Steel Center Mounted
	<i>Wheel Protection</i>	Sealed	Sealed	Sealed	Sealed	Sealed Shielded Seal/Shield Washroom	Sealed Seal/Shield
	<i>Wheel Versions</i>	Corrosion Resistant	Corrosion Resistant	Carbon Steel	Carbon Steel	Carbon Steel Corrosion Resistant Food/Pharma High/Low Temp. Vacuum Washdown	Corrosion Resistant

UTILITRAK® SERIES COMPARISON

PW Crown Wheel Plate in C Channel

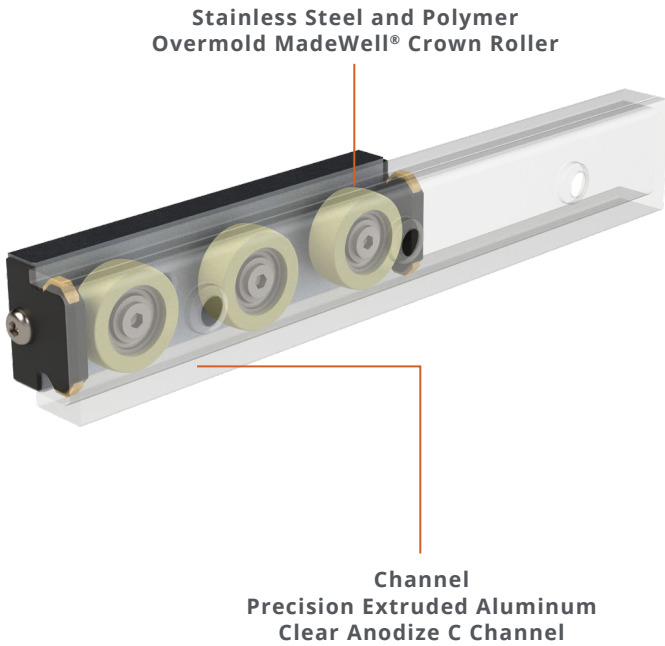

SW Wheel Plate with Vee Wheels in Vee Channel

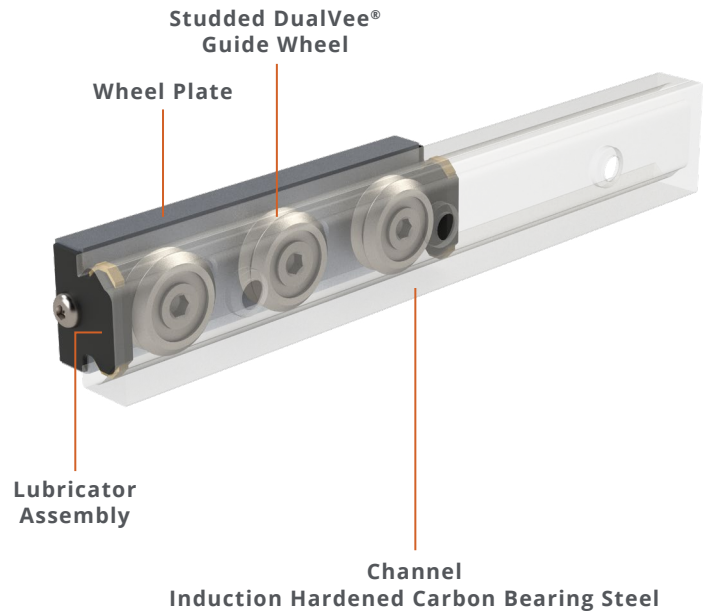

VC Wheel Plate in Vee Channel

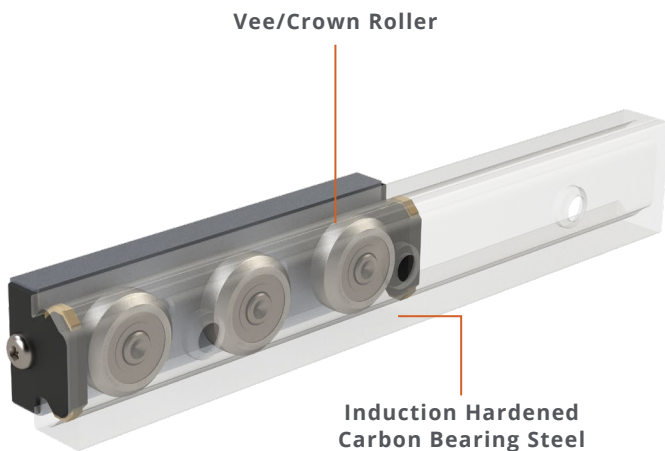

CR Wheel Plate in Composite Channel

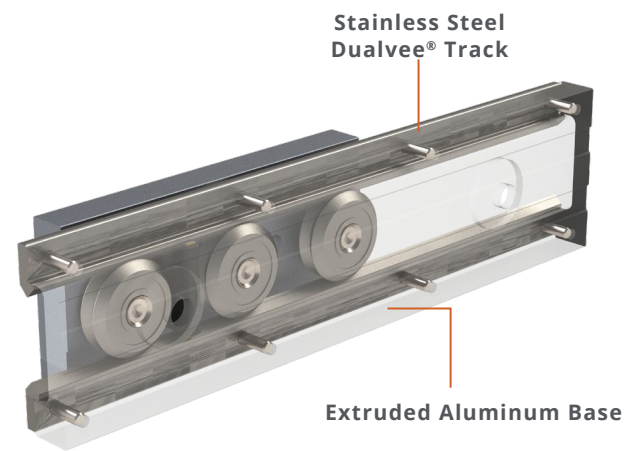

PW SERIES

The UtiliTrak® PW Series are linear bearings made with Madewell® polymer guide wheels and matching extruded aluminum linear guide track channels. The pairing of wheel plate with channel are designed and built of materials for lighter load capacities, but highly corrosive environments.

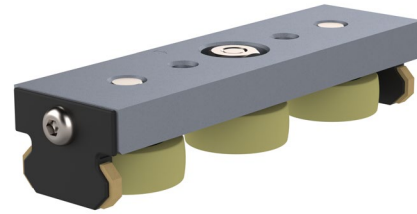

Design Benefits

- Light to medium duty applications
- High speed capacity
- Ease of installation
- Smooth anti-friction operation
- Low noise
- Vibration-resistant wheel plate option **NEW**
- Eccentric bearing for easy wheel plate adjustment
- Tolerates up to 7° of angular misalignment
- Butt-joining extruded channel for unlimited travel lengths

Key Industries

- Food Product Processing
- Agriculture
- Medical
- Testing Laboratories
- Diagnostic Substance Mfg.
- Paper/Pulping

Application Examples

- Agrochemical (liquid fertilizer) filling
- Liquid medicine & cleaning wash
- High impact cleaning spray nozzles in paper production

For instructions regarding mounting and orientation, life estimation, preloading, and maintenance, see the UtiliTrak section of the Technical Data catalog.

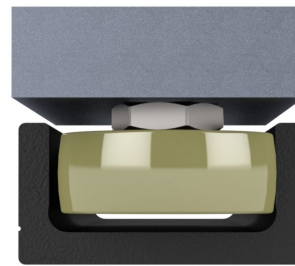

Crown Roller

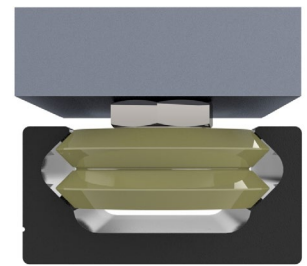

Vee Wheel

		CROWN	90° VEE
OVERVIEW	Compatible Channel	C Channel	90° Vee
	Compatible Wheel Plate	Crown Roller	90° Vee
	Loading Direction	Radial Only	Axial and Radial
	Optional Brake	Yes	Yes
	Available Sizes	0, 1, 2	0, 1, 2
CHANNEL	Material(s)	Aluminum	Aluminum
	Standard Coating	Clear Anodize	Clear Anodize
	Hardened	No	No
	Finish	Extruded	Extruded
WHEEL PLATE	# of Wheels	3, 4, 5	3, 4, 5
	Bearings	Single Row Deep Groove	Single Row Deep Groove
	Wheel Material	Polymer Overmold Stainless Steel	Polymer Overmold Stainless Steel
	Wheel Material Grade	Polyacetal and 440C	Polyacetal and 440C
	Max Angular Misalignment	+/- 7°	0°
	Vibration-Resistant Lock Nut	Optional	Optional
	Wheel Bottom Hex Feature (Size 2 and 3)	Standard	Standard
	Preloaded Adjustment Hex	Metric	Metric
	Lubrications	Molded Nylon End Caps	Molded Nylon End Caps
	Wheel Protection	Shielded	Shielded
	Wheel Versions	Corrosion Resistant	Corrosion Resistant

PW SERIES

Application Examples

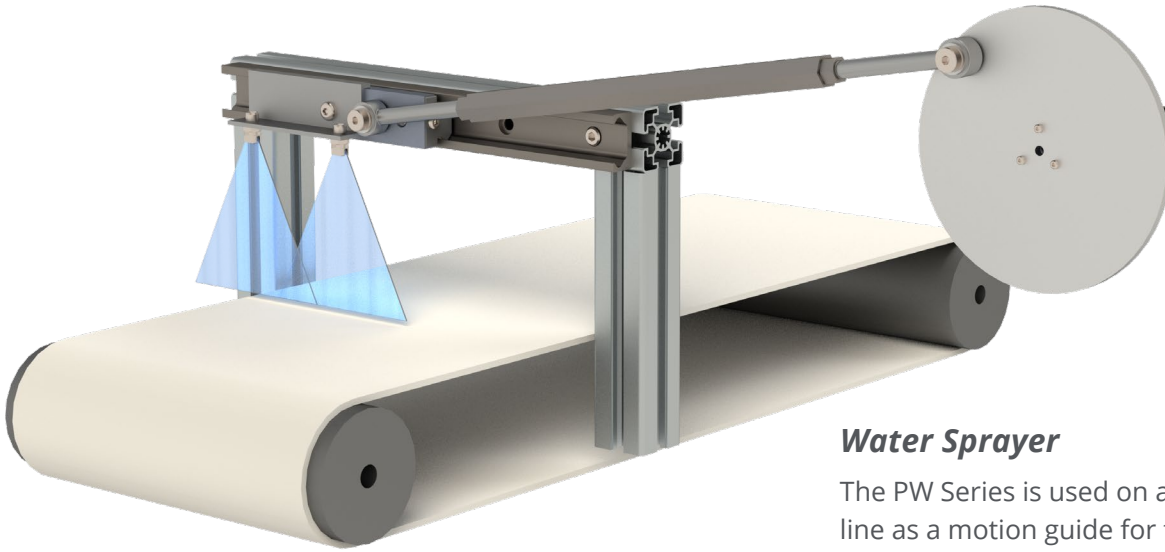

Water Sprayer

The PW Series is used on a food processing line as a motion guide for the spray application of liquid preservatives. Anodized aluminum with stainless steel guide wheel bearings are combined with polymer wheels for corrosion resistant operation.

Laboratory Liquid Dispensing

Multi-axis laboratory automation for high throughput fluid pipetting. The small footprint linear guides are made from corrosion resistant aluminum, stainless steel, and polymer wheels that are well suited for lightweight tabletop instrumentation and low contamination but highly corrosive environments.

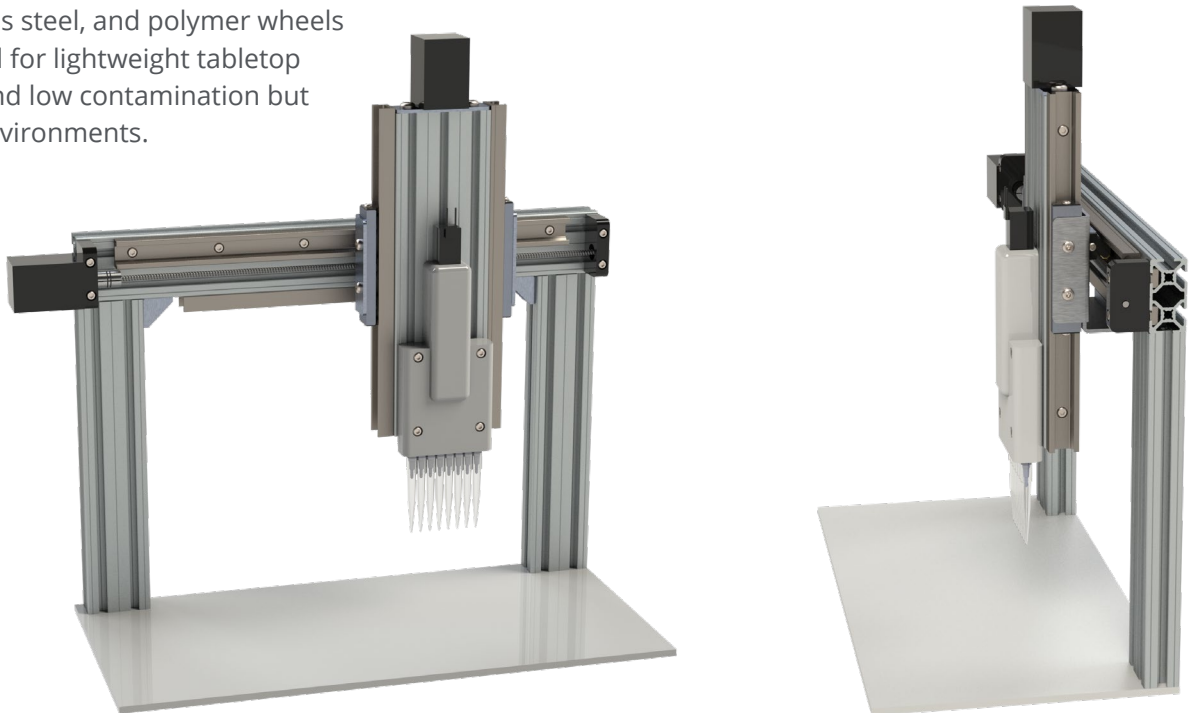

PW SERIES

Wheel Plate Stock Code, Mass, and Max Load Capacity

See the Technical Data catalog page 24 - 26 for sizing/selection and life estimation.

SIZE	# OF WHEELS	STOCK CODE*	MASS (G)	RADIAL L _R		AXIAL L _A		PITCH M _p		YAW M _y		ROLL M _r	
				(N)	(LBF)	(N)	(LBF)	(N-M)	(LBF-FT)	(N-M)	(LBF-FT)	(N-M)	(LBF-FT)
0	3	UT0WPAP	46	53	12	38	9	0.6	0.5	0.6	0.5	0.2	0.1
	4	UT0WPAP-4A	60	53	12	46	10	21.1	15.6	1.8	1.3	0.4	0.3
	5	UT0WPAP-5A	90	63	14	54	12	21.1	15.6	1.8	1.3	0.4	0.3
1	3	UT1WPAP	92	107	24	76	17	2.0	1.5	2.0	1.5	0.5	0.4
	4	UT1WPAP-4A	120	107	24	91	20	61.5	45.4	5.1	3.8	1.0	0.7
	5	UT1WPAP-5A	160	127	30	107	24	61.5	45.4	5.1	3.8	1.0	0.7
2	3	UT2WPAP	243	142	32	94	21	3.6	2.7	3.2	2.4	1.2	0.9
	4	UT2WPAP-5A	315	142	32	113	25	124.9	92.1	9.3	6.8	2.3	1.7
	5	UT2WPAP-5A	340	169	38	133	30	124.9	92.1	9.3	6.8	2.3	1.7

SIZE	# OF WHEELS	STOCK CODE*	MASS (G)	RADIAL L _R		AXIAL L _A		PITCH M _p		YAW M _y		ROLL M _r	
				(N)	(LBF)	(N)	(LBF)	(N-M)	(LBF-FT)	(N-M)	(LBF-FT)	(N-M)	(LBF-FT)
0	3	UT0WPAPR	47	53	12	0	0	0	0	0.6	0.5	0	0
	4	UT0WPAPR-4A	60	53	12	0	0	0	0	1.8	1.3	0	0
	5	UT0WPAPR-5A	90	63	14	0	0	0	0	1.8	1.3	0	0
1	3	UT1WPAPR	94	107	24	0	0	0	0	2.0	1.5	0	0
	4	UT1WPAPR-4A	120	107	24	0	0	0	0	5.1	3.8	0	0
	5	UT1WPAPR-5A	160	127	30	0	0	0	0	5.1	3.8	0	0
2	3	UT2WPAPR	246	142	32	0	0	0	0	3.2	2.4	0	0
	4	UT2WPAPR-5A	315	142	32	0	0	0	0	9.3	6.8	0	0
	5	UT2WPAPR-5A	340	169	38	0	0	0	0	9.3	6.8	0	0

*For vibration-resistant lock nut option, replace "WPA" with "WPLA" in stock code. Prevailing torque lock nuts are 304 stainless steel, resistant to high/low temp. & chemicals.

Clear Anodized Channel Stock Code

C Channel	90° Vee
UTTRA0 (L) (M)	UTTA0 (L) (M)
UTTRA1 (L) (M)	UTTA1 (L) (M)
UTTRA2 (L) (M)	UTTA2 (L) (M)

(L) is channel length in mm with 1 decimal place (up to 3600.0 mm); butt-join channel for unlimited travel lengths.

(M) is custom Hole to End space for one end in mm with 1 decimal place (9.0 to 72.0 mm). Leave blank for default value on both ends.

Example: UTTRA1 2160.0 20.5
Example: UTTA2 1030.5

To Calculate Hole to End Space (Dimension M)

Step 1: Calculate number of hole spaces

$$\frac{\text{Length in mm} - X}{80} = \# \text{ of hole spaces (round down to nearest whole number)}$$

X = 14 X = 16 X = 18
(size 0) (size 1) (size 2)

Step 2: Calculate sum of end spaces

$$\frac{\text{Length in mm} - (\# \text{ of spaces} \times 80)}{2} = \text{Sum of end lengths}$$

Step 3: Calculate M

By default $M = \frac{\text{Sum of end spaces}}{2}$

If specifying a custom M, the other end space is $(\text{Sum of end spaces}) - (\text{Specified end space } M)$.

PW SERIES

Channel

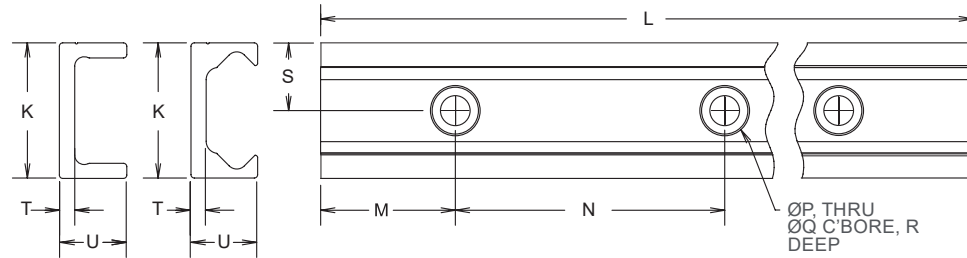

Dimensions

SIZE	CHANNEL	STOCK CODE	K	L*	M**	N	P	Q	R	S	T	U	RECOMMENDED FASTENER	
0	90° Vee	UTTA0	.787 [20.00]	141.732 ± .079 Max. [3600 ± 2 Max.]	Use Formula on Page 8 to Calculate	3.150 [80.00]	.189 [4.80]	.325 [8.26]	.118 [3.00]	.394 [10.00]	.158 [4.00]	.433 [11.00]	M4 Low Head Cap Screw	
	Crown	UTTRA0	.787 [20.00]	141.732 ± .079 Max. [3600 ± 2 Max.]		3.150 [80.00]	.189 [4.80]	.325 [8.26]	.118 [3.00]	.394 [10.00]	.158 [4.00]	.433 [11.00]		
1	90° Vee	UTTA1	1.024 [26.00]	141.732 ± .079 Max. [3600 ± 2 Max.]		Custom End Spacing Possible (9.0 to 72.0 mm)	3.150 [80.00]	.228 [5.79]	.393 [9.98]	.110 [2.79]	.512 [13.00]	.158 [4.00]	.591 [15.00]	M5 Low Head Cap Screw
	Crown	UTTRA1	1.024 [26.00]	141.732 ± .079 Max. [3600 ± 2 Max.]			3.150 [80.00]	.228 [5.79]	.393 [9.98]	.110 [2.79]	.512 [13.00]	.158 [4.00]	.591 [15.00]	
2	90° Vee	UTTA2	1.575 [40.00]	141.732 ± .079 Max. [3600 ± 2 Max.]	Custom End Spacing Possible (9.0 to 72.0 mm)		3.150 [80.00]	.347 [8.81]	.561 [14.25]	.120 [3.05]	.788 [20.00]	.177 [4.50]	.777 [19.74]	M8 Low Head Cap Screw
	Crown	UTTRA2	1.575 [40.00]	141.732 ± .079 Max. [3600 ± 2 Max.]			3.150 [80.00]	.347 [8.81]	.561 [14.25]	.120 [3.05]	.788 [20.00]	.177 [4.50]	.777 [19.74]	

*Standard cut-to-length tolerance +/- 0.06" [1.524 mm]

**Hole end spacing tolerance +/- 0.03" [0.762 mm]

3 Wheel Plate

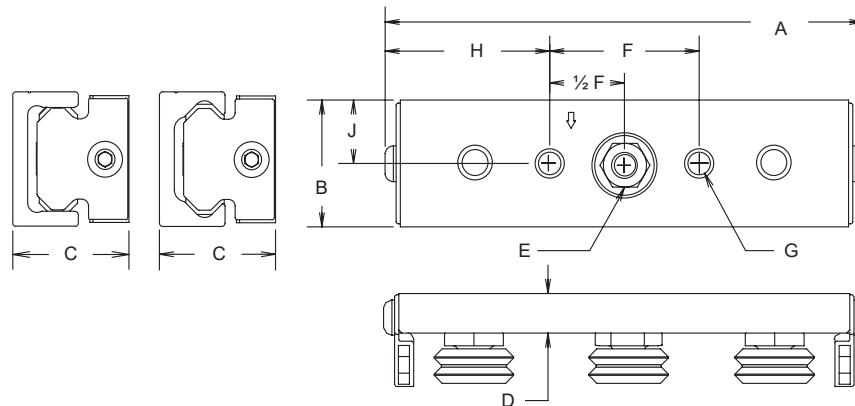

Dimensions

SIZE	WHEEL STYLE	STOCK CODE	# WHEELS	A	B	C	D	E	F	G	H	J	WHEEL WRENCH
0	90° Vee	UT0WPAP	3	3.144 [79.86]	.709 [18.00]	.866 [22.00]	.310 [7.87]	8MM SOCKET	.866 [22.00]	M4 X 0.7	1.139 [28.93]	.355 [9.02]	BAW0
	Crown	UT0WPAPR	3	3.144 [79.86]	.709 [18.00]	.866 - .909 [22.00 - 23.09]	.310 [7.87]	8MM SOCKET	.866 [22.00]	M4 X 0.7	1.139 [28.93]	.355 [9.02]	
1	90° Vee	UT1WPAP	3	4.467 [113.46]	.945 [24.00]	1.036 [26.31]	.347 [8.81]	10MM SOCKET	.1575 [40.00]	M6 X 1.0	1.446 [36.73]	.472 [12.00]	BAW1
	Crown	UT1WPAPR	3	4.467 [113.46]	.945 [24.00]	1.024 - 1.087 [26.00 - 27.61]	.347 [8.81]	10MM SOCKET	.1575 [40.00]	M6 X 1.0	1.446 [36.73]	.472 [12.00]	
2	90° Vee	UT2WPAP	3	5.675 [144.15]	1.496 [38.00]	1.377 [34.98]	.464 [11.79]	13MM SOCKET	1.772 [45.00]	M8 X 1.25	1.952 [49.58]	.748 [19.00]	BAW2
	Crown	UT2WPAPR	3	5.675 [144.15]	1.496 [38.00]	1.366 - 1.472 [34.70 - 37.39]	.464 [11.79]	13MM SOCKET	1.772 [45.00]	M8 X 1.25	1.952 [49.58]	.748 [19.00]	

Dimensions are shown in inch and [millimeter] values
Drawings are not to scale

PW SERIES

4 and 5 Wheel Plate

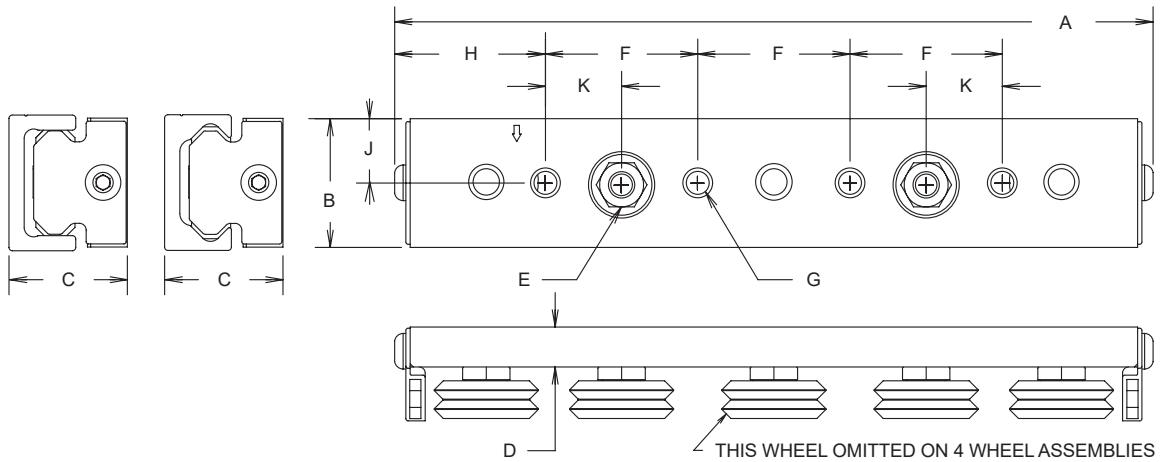

Dimensions

SIZE	WHEEL STYLE	STOCK CODE	# WHEELS	A	B	C	D	E	F	G	H	J	K	WHEEL WRENCH
0	90° Vee	UT0WPAP-4A	4	4.718 [119.84]	.709 [18.00]	.866 [22.00]	.310 [7.87]	8MM SOCKET	.866 [22.00]	M4 X 0.7	1.060 [26.92]	.355 [9.02]	.433 [11.00]	BAW0
		UT0WPAP-5A	5	4.718 [119.84]	.709 [18.00]	.866 [22.00]	.310 [7.87]	8MM SOCKET	.866 [22.00]	M4 X 0.7	1.060 [26.92]	.355 [9.02]	.433 [11.00]	
	Crown	UT0WPAPR-4A	4	4.718 [119.84]	.709 [18.00]	.866 - .909 [22.00 - 23.09]	.310 [7.87]	8MM SOCKET	.866 [22.00]	M4 X 0.7	1.060 [26.92]	.355 [9.02]	.433 [11.00]	
		UT0WPAPR-5A	5	4.718 [119.84]	.709 [18.00]	.866 - .909 [22.00 - 23.09]	.310 [7.87]	8MM SOCKET	.866 [22.00]	M4 X 0.7	1.060 [26.92]	.355 [9.02]	.433 [11.00]	
1	90° Vee	UT1WPAP-4A	4	6.553 [166.45]	.945 [24.00]	1.036 [26.31]	.347 [8.81]	10MM SOCKET	1.378 [35.00]	M6 X 1.0	1.210 [30.73]	.472 [12.00]	.807 [20.50]	BAW1
		UT1WPAP-5A	5	6.553 [166.45]	.945 [24.00]	1.036 [26.31]	.347 [8.81]	10MM SOCKET	1.378 [35.00]	M6 X 1.0	1.210 [30.73]	.472 [12.00]	.807 [20.50]	
	Crown	UT1WPAPR-4A	4	6.553 [166.45]	.945 [24.00]	1.024 - 1.087 [26.00 - 27.61]	.347 [8.81]	10MM SOCKET	1.378 [35.00]	M6 X 1.0	1.210 [30.73]	.472 [12.00]	.807 [20.50]	
		UT1WPAPR-5A	5	6.553 [166.45]	.945 [24.00]	1.024 - 1.087 [26.00 - 27.61]	.347 [8.81]	10MM SOCKET	1.378 [35.00]	M6 X 1.0	1.210 [30.73]	.472 [12.00]	.807 [20.50]	
2	90° Vee	UT2WPAP-4A	4	8.852 [224.16]	1.496 [38.00]	1.377 [34.98]	.464 [11.79]	13MM SOCKET	1.772 [45.00]	M8 X 1.25	1.755 [44.58]	.748 [19.00]	.866 [22.50]	BAW2
		UT2WPAP-5A	5	8.852 [224.16]	1.496 [38.00]	1.377 [34.98]	.464 [11.79]	13MM SOCKET	1.772 [45.00]	M8 X 1.25	1.755 [44.58]	.748 [19.00]	.866 [22.50]	
	Crown	UT2WPAPR-4A	4	8.852 [224.16]	1.496 [38.00]	1.366 - 1.472 [34.70 - 37.39]	.464 [11.79]	13MM SOCKET	1.772 [45.00]	M8 X 1.25	1.755 [44.58]	.748 [19.00]	.866 [22.50]	
		UT2WPAPR-5A	5	8.852 [224.16]	1.496 [38.00]	1.366 - 1.472 [34.70 - 37.39]	.464 [11.79]	13MM SOCKET	1.772 [45.00]	M8 X 1.25	1.755 [44.58]	.748 [19.00]	.866 [22.50]	

Dimensions are shown in inch and [millimeter] values
 Wheel plate is representative of both DualVee wheels and MadeWell crown rollers
 Drawings are not to scale

SW SERIES

The UtiliTrak® SW Series are linear bearings with a wide variety of steel and stainless steel DualVee® guide wheels and MadeWell® crown rollers, and matching precision ground channels designed to withstand heavy load capacity requirements in compact spaces and where challenging environmental conditions such as washdown, or high contamination or debris exist.

Design Benefits

- Medium to heavy duty applications
- Ease of installation
- High speed capacity
- Smooth anti-friction operation
- Low noise
- Vibration-resistant wheel plate option **NEW**
- Eccentric bearing for easy wheel plate adjustment
- Tolerates up to 7° of angular misalignment
- Butt-joining drawn and extruded channel for unlimited travel lengths
- Special bearing options to suit the environment

Key Industries

- Aeronautical
- Cutting, Slicing, & Slitting
- Food Processing
- Medical
- Packaging
- Welding
- Pharmaceutical
- Search, Detection, & Scanning
- Transportation

Application Examples

- Adjustable seats
- Equipment trays and slide-outs
- Adjustable position & lock mechanisms
- Material processing & handling equipment

For instructions regarding mounting and orientation, life estimation, preloading, and maintenance, see the UtiliTrak section of the Technical Data catalog.

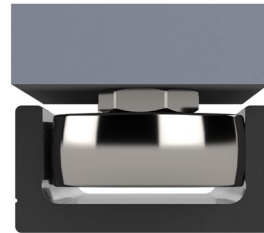

Crown Roller

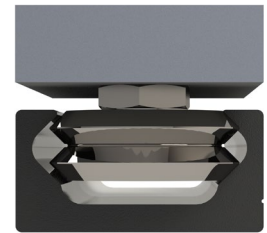

Vee Wheel

		CROWN	90° VEE
OVERVIEW	<i>Compatible Channel</i>	C Channel	90° Vee
	<i>Compatible Wheel Plate</i>	Crown Roller	90° Vee
	<i>Loading Direction</i>	Radial Only	Axial and Radial
	<i>Optional Brake</i>	Yes	Yes
	<i>Available Sizes</i>	1, 2, 3	1, 2, 3
CHANNEL	<i>Material(s)</i>	Carbon Steel	Carbon Steel
	<i>Standard Coating(s)</i>	Polyurethane Paint Black Oxide	Polyurethane Paint Black Oxide
	<i>Hardened</i>	53 HR _c	53 HR _c
	<i>Finish</i>	Precision Ground	Precision Ground
WHEEL PLATE	<i># of Wheels</i>	3, 4, 5	3, 4, 5
	<i>Bearings</i>	Double Row Angular Contact	Double Row Angular Contact
	<i>Wheel Material</i>	Carbon Steel	Carbon Steel Stainless Steel
	<i>Material Grade</i>	52100	52100 or 440C
	<i>Max. Angular Misalignment</i>	+/- 7°	0°
	<i>Vibration-Resistant Lock Nut</i>	Optional	Optional
	<i>Wheel Bottom Hex Feature (Size 2 and 3)</i>	Optional	Optional
	<i>Preloaded Adjustment Hex</i>	Inch	Inch
	<i>Lubrications</i>	Molded Nylon End Caps	Molded Nylon End Caps
	<i>Wheel Protection</i>	Sealed	Shielded Seal/Shield Washdown
	<i>Wheel Versions</i>	Carbon Steel	Carbon Steel Corrosion Resistant Food/Pharma High/Low Temp. Vacuum Washdown

SW SERIES

Application Examples

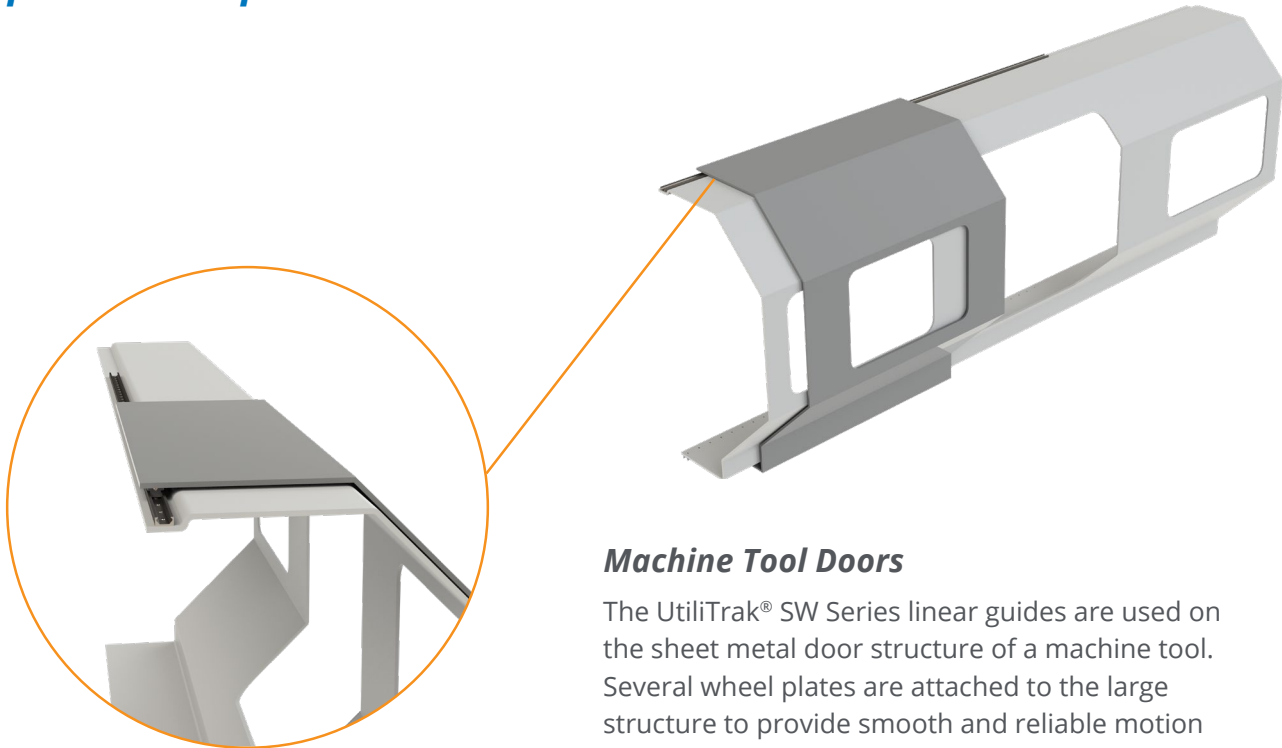

Machine Tool Doors

The UtiliTrak® SW Series linear guides are used on the sheet metal door structure of a machine tool. Several wheel plates are attached to the large structure to provide smooth and reliable motion within the debris contaminated environment.

Spindle Assembly

The UtiliTrak® SW Series can be used on the vertical z-axis of a CNC routing machine to guide the routing spindle. The machine utilizes a combination of channel profiles to prevent binding in the spindle assembly with a vee channel with vee guide wheels on one side, and a C channel with crown rollers on the opposite side.



SW SERIES

Wheel Plate Max Load Capacity

See the Technical Data catalog page 24 - 26 for sizing/selection and life estimation.

SIZE	# OF WHEELS	STOCK CODE*	MASS (G)	RADIAL L _R		AXIAL L _A		PITCH M _P		YAW M _Y		ROLL M _R	
				(N)	(LBF)	(N)	(LBF)	(N-M)	(LBF-FT)	(N-M)	(LBF-FT)	(N-M)	(LBF-FT)
1	3	UT1WPA	114	2440	549	719	162	18	13.3	30.5	22.5	7.0	5.2
	4	UT1WPA-4A	163	2440	549	862	194	32.3	23.8	45.8	33.8	9.8	7.2
	5	UT1WPA-5A	181	2900	652	1014	228	32.3	23.8	45.8	33.8	12.6	9.3
1	3	UT1WPAX	114	2440	549	719	162	18	13.3	30.5	22.5	7.0	5.2
	4	UT1WPAX-4A	163	2440	549	862	194	32.3	23.8	45.8	33.8	9.8	7.2
	5	UT1WPAX-5A	181	2900	652	1014	228	32.3	23.8	45.8	33.8	12.6	9.3
1	3	UT1SSXWPA	114	1952	439	575	129	14.4	10.6	24.4	18	5.6	4.1
	4	UT1SSXWPA-4A	163	1952	439	690	155	25.8	19.1	36.6	27	7.8	5.8
	5	UT1SSXWPA-5A	181	2318	522	811	182	25.8	19.1	36.6	27	10.1	7.5
1	3	UT1SS227WPA	114	1952	439	575	129	14.4	10.6	24.4	18	5.6	4.1
	4	UT1SS227WPA-4A	163	1952	439	690	155	25.8	19.1	36.6	27	7.8	5.8
	5	UT1SS227WPA-5A	181	2318	522	811	182	25.8	19.1	36.6	27	10.1	7.5
1	3	UT1SS300WPA	114	1952	439	575	129	14.4	10.6	24.4	18	5.6	4.1
	4	UT1SS300WPA-4A	163	1952	439	690	155	25.8	19.1	36.6	27	7.8	5.8
	5	UT1SS300WPA-5A	181	2318	522	811	182	25.8	19.1	36.6	27	10.1	7.5
2	3	UT2WPAXS	330	5300	1191	1475	332	58	42.8	100	73.8	22.7	16.7
	4	UT2WPAXS-4A	479	5300	1191	1770	398	107	78.9	150	110.6	31.8	23.5
	5	UT2WPAXS-5A	543	6300	1416	2080	468	107	78.9	150	110.6	40.9	30.2
2	3	UT2SSXWPA	330	4240	953	1180	265	46.4	34.2	80	59	18.2	13.4
	4	UT2SSXWPA-4A	479	4240	953	1416	318	85.6	63.2	120	88.6	25.4	18.8
	5	UT2SSXWPA-5A	543	5040	1133	1664	374	85.6	63.2	120	88.6	32.7	24.1
2	3	UT2SS227WPA	330	4240	953	1180	265	46.4	34.2	80	59	18.2	13.4
	4	UT2SS227WPA-4A	479	4240	953	1416	318	85.6	63.2	120	88.6	25.4	18.8
	5	UT2SS227WPA-5A	543	5040	1133	1664	374	85.6	63.2	120	88.6	32.7	24.1
2	3	UT2SS300WPA	330	4240	953	1180	265	46.4	34.2	80	59	18.2	13.4
	4	UT2SS300WPA-4A	479	4240	953	1416	318	85.6	63.2	120	88.6	25.4	18.8
	5	UT2SS300WPA-5A	543	5040	1133	1664	374	85.6	63.2	120	88.6	32.7	24.1
3	3	UT3WPAXS	943	11800	2653	5100	1147	229	168.9	346	255.2	118	87
	4	UT3WPAXS-4A	1370	11800	2653	6122	1376	408	300.9	519	382.8	165.2	121.8
	5	UT3WPAXS-5A	1533	14040	3156	7140	1605	408	300.9	519	382.8	212.4	156.7
3	3	UT3SS227WPA	943	9440	2122	4080	917	183.2	135.2	276.8	204.3	94.4	69.7
	4	UT3SS227WPA-4A	1370	9440	2122	4898	1101	326.4	240.9	415.2	306.4	132.2	97.5
	5	UT3SS227WPA-5A	1533	11210	2525	5711	1284	326.4	240.9	415.2	306.4	169.9	125.4
3	3	UT3SS300WPA	943	9440	2122	4080	917	183.2	135.2	276.8	204.3	94.4	69.7
	4	UT3SS300WPA-4A	1370	9440	2122	4898	1101	326.4	240.9	415.2	306.4	132.2	97.5
	5	UT3SS300WPA-5A	1533	11210	2525	5711	1284	326.4	240.9	415.2	306.4	169.9	125.4

90° VEE

*Stock Code Key: UTnWPAX: Carbon, Sealed
 UTnWPA: Carbon, Shielded
 UTnWPAXS: Carbon, Seal/Shield

UTnSSXWPA: Stainless, Sealed
 UTnSS227: Stainless, High Temp
 UTnSS300: Stainless, Low Temp

For vibration-resistant lock nut option, replace "WPA" with "WPLA" in stock code. Prevailing torque lock nuts are 304 stainless steel, resistant to high/low temp. and chemicals.

SW SERIES

Wheel Plate Max Load Capacity

See the Technical Data catalog page 24 - 26 for sizing/selection and life estimation.

SIZE	# OF WHEELS	STOCK CODE*	MASS (G)	RADIAL L_r		AXIAL L_A		PITCH M_p		YAW M_y		ROLL M_R	
				(N)	(LBF)	(N)	(LBF)	(NM)	(LBF-FT)	(NM)	(LBF-FT)	(NM)	(LBF-FT)
1	3	UT1WPAR	121	2440	549	0	0	0	0	30.5	22.5	0	0
	4	UT1WPAR-4A	195	2440	549	0	0	0	0	45.8	33.8	0	0
	5	UT1WPAR-5A	220	2900	652	0	0	0	0	45.8	33.8	0	0
1	3	UT1WPAXR	121	2440	549	0	0	0	0	30.5	22.5	0	0
	4	UT1WPAXR-4A	195	2440	549	0	0	0	0	45.8	33.8	0	0
	5	UT1WPAXR-5A	220	2900	652	0	0	0	0	45.8	33.8	0	0
2	3	UT2WPAR	320	5300	1191	0	0	0	0	100	73.8	0	0
	4	UT2WPAR-4A	522	5300	1191	0	0	0	0	150	110.6	0	0
	5	UT2WPAR-5A	598	6300	1416	0	0	0	0	150	110.6	0	0
2	3	UT2WPAXR	320	5300	1191	0	0	0	0	100	73.8	0	0
	4	UT2WPAXR-4A	522	5300	1191	0	0	0	0	150	110.6	0	0
	5	UT2WPAXR-5A	598	6300	1416	0	0	0	0	150	110.6	0	0
3	3	UT3WPAXR	910	11800	2653	0	0	0	0	346	255.2	0	0
	4	UT3WPAXR-4A	1478	11800	2653	0	0	0	0	519	382.8	0	0
	5	UT3WPAXR-5A	1665	14040	3156	0	0	0	0	519	382.8	0	0

*For vibration-resistant lock nut option, replace "WPA" with "WPLA" in stock code.

Clear Anodized Channel Stock Code

C Channel

UTTRS1 (L) (M)
UTTRS2 (L) (M)
UTTRS3 (L) (M)

90° Vee

UTTS1 (L) (M)
UTTS2 (L) (M)
UTTS3 (L) (M)

(L) is channel length in mm with 1 decimal place (up to 3600.0 mm); butt-join channel for unlimited travel lengths.

(M) is custom Hole to End space for one end in mm with 1 decimal place (9.0 to 72.0 mm). Leave blank for default value on both ends.

Example: UTTRS1 2160.0 20.5
Example: UTTS2 1030.5

To Calculate Hole to End Space (Dimension M)

Step 1: Calculate number of hole spaces

$\frac{\text{Length in mm} - X}{80} = \# \text{ of hole spaces (round down to nearest whole number)}$

X = 16 (size 1) X = 18 (size 2) X = 20 (size 3)

Step 2: Calculate sum of end spaces

$\frac{\text{Length in mm} - (\# \text{ of spaces} \times 80)}{2} = \text{Sum of end spaces}$

Step 3: Calculate M

By default $M = \frac{\text{Sum of end spaces}}{2}$

If specifying a custom M, the other end space is $(\text{Sum of end spaces}) - (\text{Specified end space } M)$.

SW SERIES

Channel

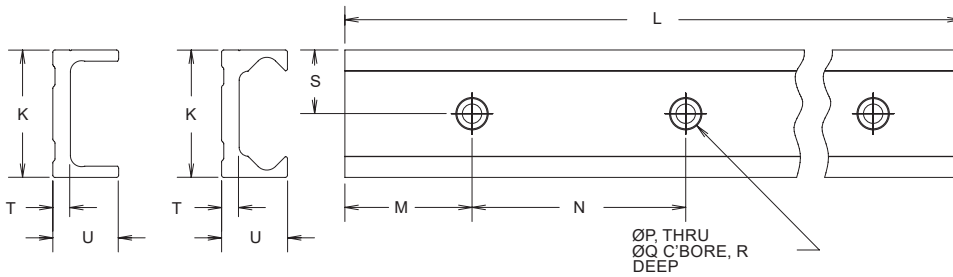

Dimensions

SIZE	CHANNEL	STOCK CODE	K	L*	M**	N	P	Q	R	S	T	U	RECOMMENDED FASTENER
1	90° Vee	UTTS1	1.024 [26.00]	141.732 ± .079 Max. [3600 ± 2 Max.]	Use Formula on Page 14 to Calculate	3.150 [80.00]	.228 [5.79]	.393 [9.98]	.110 [2.79]	.512 [13.00]	.158 [4.00]	.591 [15.00]	M5 Low Head Cap Screw
	Crown	UTTRS1	1.024 [26.00]	141.732 ± .079 Max. [3600 ± 2 Max.]		3.150 [80.00]	.228 [5.79]	.393 [9.98]	.110 [2.79]	.512 [13.00]	.158 [4.00]	.591 [15.00]	
2	90° Vee	UTTS2	1.575 [40.00]	141.732 ± .079 Max. [3600 ± 2 Max.]	Custom End Spacing Possible (9.0 to 72.0 mm)	3.150 [80.00]	.347 [8.81]	.561 [14.25]	.120 [3.05]	.788 [20.00]	.177 [4.50]	.777 [19.74]	M8 Low Head Cap Screw
	Crown	UTTRS2	1.575 [40.00]	141.732 ± .079 Max. [3600 ± 2 Max.]		3.150 [80.00]	.347 [8.81]	.561 [14.25]	.120 [3.05]	.788 [20.00]	.177 [4.50]	.777 [19.74]	
3	90° Vee	UTTS3	2.284 [58.00]	141.732 ± .079 Max. [3600 ± 2 Max.]	Custom End Spacing Possible (9.0 to 72.0 mm)	3.150 [80.00]	.347 [8.81]	.561 [14.25]	.197 [5.00]	1.142 [29.00]	.315 [8.00]	1.180 [29.97]	M8 Low Head Cap Screw
	Crown	UTTRS3	2.284 [58.00]	141.732 ± .079 Max. [3600 ± 2 Max.]		3.150 [80.00]	.347 [8.81]	.561 [14.25]	.197 [5.00]	1.142 [29.00]	.315 [8.00]	1.180 [29.97]	

*Standard cut-to-length tolerance +/- 0.06" [1.524 mm]

**Hole end spacing tolerance +/- 0.03" [0.762 mm]

3 Wheel Plate

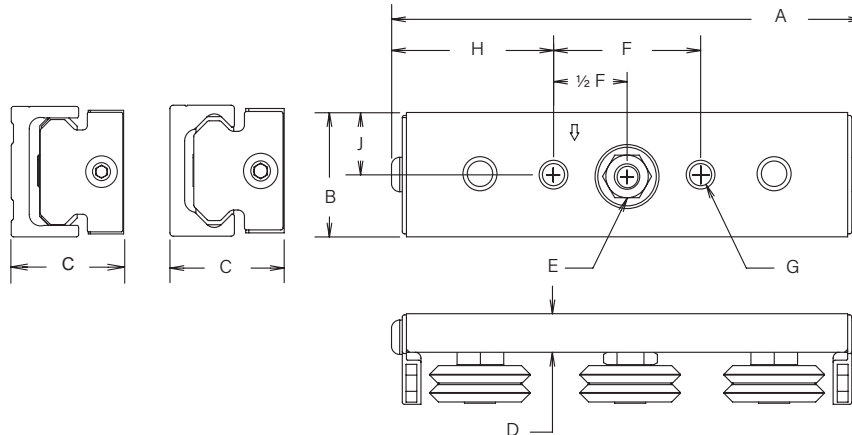

Dimensions

SIZE	WHEEL STYLE	STOCK CODE	# WHEELS	A	B	C	D	E*	F	G	H	J	WHEEL WRENCH
1	90° Vee	Various Wheel Versions and Materials are Available.	3	4.467 [113.46]	.945 [24.00]	1.036 [26.31]	.347 [8.81]	10MM SOCKET	.1575 [40.00]	M6 X 1.0	1.446 [36.73]	.472 [12.00]	BAW1
	Crown		3	4.467 [113.46]	.945 [24.00]	1.024 - 1.087 [26.00 - 27.61]	.347 [8.81]	10MM SOCKET	.1575 [40.00]	M6 X 1.0	1.446 [36.73]	.472 [12.00]	
2	90° Vee	See Page 13 Options.	3	5.675 [144.15]	1.496 [38.00]	1.377 [34.98]	.464 [11.79]	13MM SOCKET	1.772 [45.00]	M8 X 1.25	1.952 [49.58]	.748 [19.00]	BAW2
	Crown		3	5.675 [144.15]	1.496 [38.00]	1.366 - 1.472 [34.70 - 37.39]	.464 [11.79]	13MM SOCKET	1.772 [45.00]	M8 X 1.25	1.952 [49.58]	.748 [19.00]	
3	90° Vee	See Page 13 Options.	3	7.926 [201.32]	2.165 [55.00]	1.968 [50.00]	.620 [15.75]	15MM SOCKET*	2.362 [60.00]	M10 X 1.5	2.782 [70.66]	1.083 [27.50]	BAW3
	Crown		3	7.926 [201.32]	2.165 [55.00]	1.846 - 2.102 [46.89 - 53.40]	.620 [15.75]	15MM SOCKET*	2.362 [60.00]	M10 X 1.5	2.782 [70.66]	1.083 [27.50]	

Dimensions are shown in inch and [millimeter] values

Drawings are not to scale

*Size 3 wheel plate assemblies with vibration-resistant lock nuts ("WPLA" in stock code) use 17MM SOCKET

SW SERIES

4 and 5 Wheel Plate

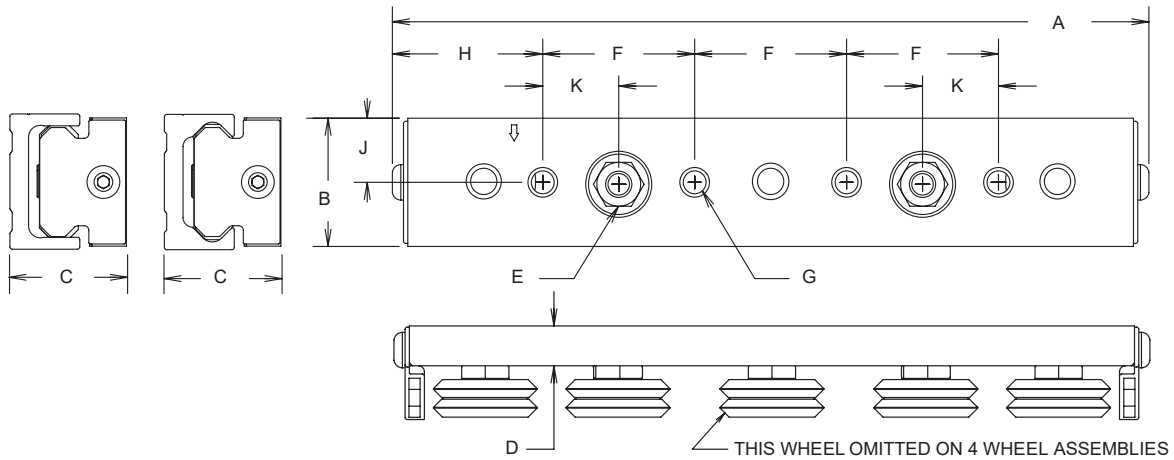

Dimensions														
SIZE	WHEEL STYLE	STOCK CODE	# WHEELS	A	B	C	D	E*	F	G	H	J	K	WHEEL WRENCH
1	90° Vee		4	6.553 [166.45]	.945 [24.00]	1.036 [26.31]	.347 [8.81]	10MM SOCKET	1.378 [35.00]	M6 X 1.0	1.210 [30.73]	.472 [12.00]	.807 [20.50]	BAW1
			5	6.553 [166.45]	.945 [24.00]	1.036 [26.31]	.347 [8.81]	10MM SOCKET	1.378 [35.00]	M6 X 1.0	1.210 [30.73]	.472 [12.00]	.807 [20.50]	
	Crown		4	6.553 [166.45]	.945 [24.00]	1.024 - 1.087 [26.00 - 27.61]	.347 [8.81]	10MM SOCKET	1.378 [35.00]	M6 X 1.0	1.210 [30.73]	.472 [12.00]	.807 [20.50]	
			5	6.553 [166.45]	.945 [24.00]	1.024 - 1.087 [26.00 - 27.61]	.347 [8.81]	10MM SOCKET	1.378 [35.00]	M6 X 1.0	1.210 [30.73]	.472 [12.00]	.807 [20.50]	
2	90° Vee	Various Wheel Versions and Materials are Available. See Page 13 Options.	4	8.852 [224.16]	1.496 [38.00]	1.377 [34.98]	.464 [11.79]	13MM SOCKET	1.772 [45.00]	M8 X 1.25	1.755 [44.56]	.748 [19.00]	.866 [22.50]	BAW2
			5	8.852 [224.16]	1.496 [38.00]	1.377 [34.98]	.464 [11.79]	13MM SOCKET	1.772 [45.00]	M8 X 1.25	1.755 [44.56]	.748 [19.00]	.866 [22.50]	
	Crown		4	8.852 [224.16]	1.496 [38.00]	1.366 - 1.472 [34.70 - 37.39]	.464 [11.79]	13MM SOCKET	1.772 [45.00]	M8 X 1.25	1.755 [44.56]	.748 [19.00]	.866 [22.50]	
			5	8.852 [224.16]	1.496 [38.00]	1.366 - 1.472 [34.70 - 37.39]	.464 [11.79]	13MM SOCKET	1.772 [45.00]	M8 X 1.25	1.755 [44.56]	.748 [19.00]	.866 [22.50]	
3	90° Vee		4	12.493 [317.32]	2.165 [55.00]	1.968 [50.00]	.620 [15.75]	15MM SOCKET*	2.362 [60.00]	M10 X 1.5	2.704 [68.68]	1.083 [27.50]	1.181 [30.00]	BAW3
			5	12.493 [317.32]	2.165 [55.00]	1.968 [50.00]	.620 [15.75]	15MM SOCKET*	2.362 [60.00]	M10 X 1.5	2.704 [68.68]	1.083 [27.50]	1.181 [30.00]	
	Crown		4	12.493 [317.32]	2.165 [55.00]	1.846 - 2.102 [46.89 - 53.40]	.620 [15.75]	15MM SOCKET*	2.362 [60.00]	M10 X 1.5	2.704 [68.68]	1.083 [27.50]	1.181 [30.00]	
			5	12.493 [317.32]	2.165 [55.00]	1.846 - 2.102 [46.89 - 53.40]	.620 [15.75]	15MM SOCKET*	2.362 [60.00]	M10 X 1.5	2.704 [68.68]	1.083 [27.50]	1.181 [30.00]	

Dimensions are shown in inch and [millimeter] values
 Wheel plate is representative of both DualVee wheels and MadeWell crown rollers
 Drawings are not to scale
 *Size 3 wheel plate assemblies with vibration-resistant lock nuts ("WPLA" in stock code) use 17MM SOCKET

VC SERIES

The UtiliTrak® VC is a compact hybrid design of the DualVee® wheels and MadeWell® crown rollers perfect for commercial applications. It highlights the ease of selection by seamlessly pairing with both vee and C channel profiles to fit your application.

Design Benefits

- Ease of installation
- Versatility between vee and C channel profiles
- High speed capacity
- Very low rolling friction operation
- Low noise
- Vibration-resistant wheel plate option **NEW**
- Eccentric bearing for easy wheel plate adjustment
- Tolerates up to 2° of angular misalignment
- Butt-joining precision ground channel for unlimited travel lengths

Key Industries

- Aerospace
- Architecture
- Automotive
- Medical
- Packaging
- Printing

Application Examples

- Sliding doors, windows, & partitions
- Adjustable and movable walls and furniture for reduced square footage
- Adjustable seats
- Equipment trays and slide-outs
- Material handling equipment
- Product indexing, cartoning and packaging

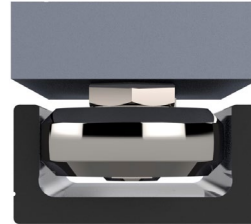

C Channel

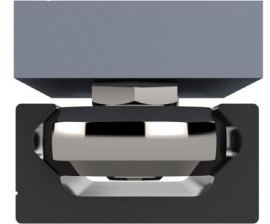

Vee Channel

		90° VEE / CROWN ROLLER
OVERVIEW	Compatible Channel	90° Vee & C Channel
	Compatible Wheel Plate	90° Vee / C Channel
	Loading Direction	Vee = Axial and Radial Crown = Radial Only
	Optional Brake	Yes
	Available Sizes	1, 2, 3
CHANNEL	Material(s)	Carbon Steel
	Standard Coating(s)	Polyurethane Paint
	Hardened	Yes
	Finish	Precision Ground
WHEEL PLATE	# of Wheels	3, 4, 5
	Bearing	Double Row Angular Contact
	Wheel Material	Carbon Steel
	Wheel Material Grade	52100
	Max. Angular Misalignment	+/- 2°
	Vibration-Resistant Lock Nut	Optional
	Wheel Bottom Hex Feature	Not Available
	Preloaded Adjustment Hex	Metric
	Lubrications	Molded Nylon End Caps
	Wheel Protection	Sealed
Wheel Versions	Carbon Steel	

For instructions regarding mounting and orientation, life estimation, preloading, and maintenance, see the UtiliTrak section of the Technical Data catalog.

VC SERIES

Application Examples

Medical Table

The UtiliTrak® VC Series is a compact solution perfect for applications such as medical tables that need to be able to adjust and move with limited space.

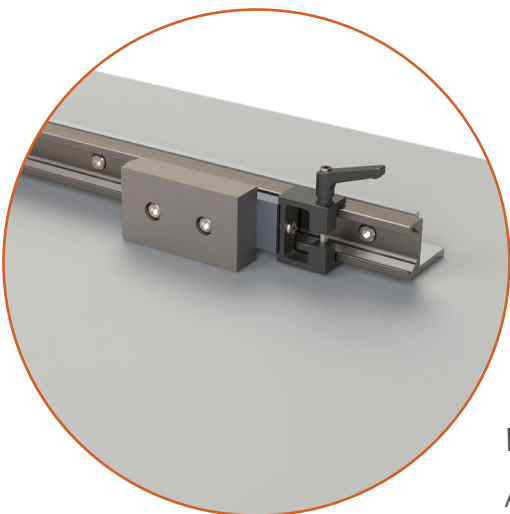
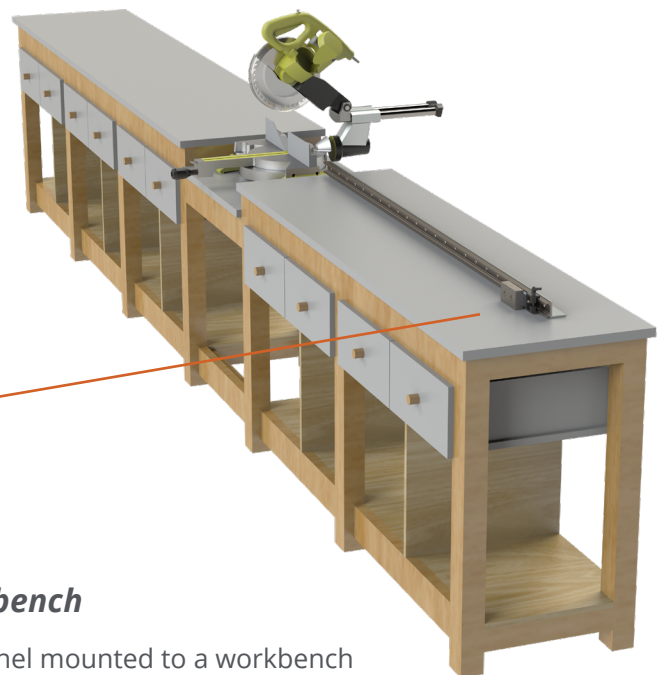
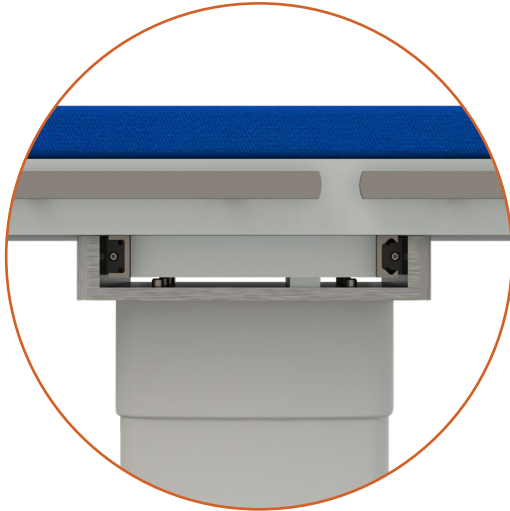
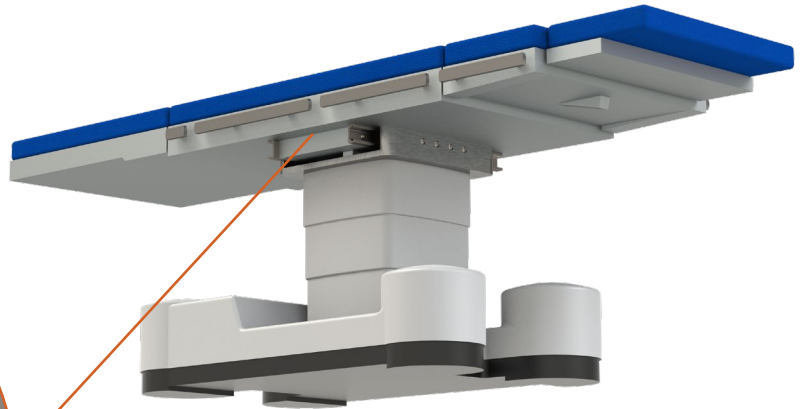

Workbench

A channel mounted to a workbench acts as a guide when utilizing the wheel plate as a method for pushing material towards a saw. A hand brake is added for manually setting the braking point.

VC SERIES

Wheel Plate Max Load Capacity

See the Technical Data catalog page 24 - 26 for sizing/selection and life estimation.

SIZE	# OF WHEELS	STOCK CODE*	MASS (G)	RADIAL L_r		AXIAL L_a		PITCH M_p		YAW M_y		ROLL M_r	
				(N)	(LBF)	(N)	(LBF)	(N-M)	(LBF-FT)	(N-M)	(LBF-FT)	(N-M)	(LBF-FT)
1	3	UTVC1XWPA	121	2440	549	719	162	18	13.3	30.5	22.5	7.0	5.2
	4	UTVC1XWPA4	173	2440	549	862	194	32.3	23.8	45.8	33.8	9.8	7.2
	5	UTVC1XWPA5	193	2900	652	1014	228	32.3	23.8	45.8	33.8	12.6	9.3
2	3	UTVC2XWPA	348	5300	1191	1475	332	58	42.8	100	73.8	22.7	16.7
	4	UTVC2XWPA4	503	5300	1191	1770	398	107	78.9	150	110.6	31.8	23.5
	5	UTVC2XWPA5	573	6300	1416	2080	468	107	78.9	150	110.6	40.9	30.2
3	3	UTVC3XWPA	999	11800	2653	5100	1147	229	168.9	346	255.2	118	87
	4	UTVC3XWPA4	1446	11800	2653	6122	1376	408	300.9	519	382.8	165.2	121.8
	5	UTVC3XWPA5	1632	14040	3156	7140	1605	408	300.9	519	382.8	212.4	156.7

*For vibration-resistant lock nut option, replace "WPA" with "WPLA" in stock code. Prevailing torque lock nuts are 304 stainless steel, resistant to high/low temp. & chemicals.



Clear Anodized Channel Stock Code

C Channel

UTTRS1 (L) (M)

UTTRS2 (L) (M)

UTTRS3 (L) (M)

90° Vee

UTTS1 (L) (M)

UTTS2 (L) (M)

UTTS3 (L) (M)

(L) is channel length in mm with 1 decimal place (up to 3600.0 mm); butt-join channel for unlimited travel lengths.

(M) is custom Hole to End space for one end in mm with 1 decimal place (9.0 to 72.0 mm). Leave blank for default value on both ends.

Example: UTTRS1 2160.0 20.5

Example: UTTS2 1030.5

To Calculate Hole to End Space (Dimension M)

Step 1: Calculate number of hole spaces

$$\frac{\text{Length in mm} - X}{80} = \# \text{ of hole spaces (round down to nearest whole number)}$$

X = 16 (size 1) X = 18 (size 2) X = 20 (size 3)

Step 2: Calculate sum of end spaces

$$\frac{\text{Length in mm} - (\# \text{ of spaces} \times 80)}{2} = \text{Sum of end lengths}$$

Step 3: Calculate M

By default
$$M = \frac{\text{Sum of end spaces}}{2}$$

If specifying a custom M, the other end space is
$$(\text{Sum of end spaces}) - (\text{Specified end space } M)$$

VC SERIES

Channel

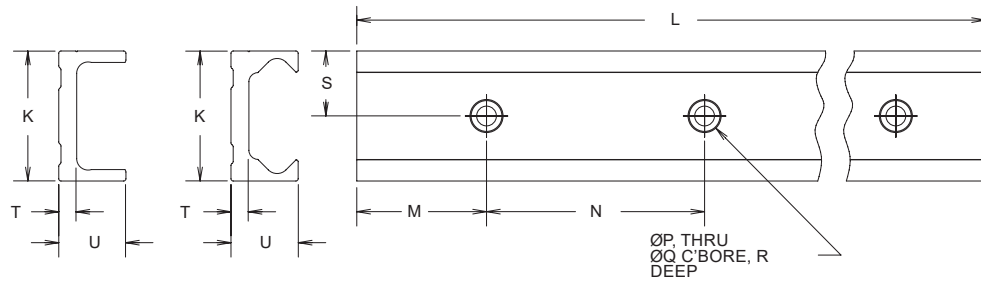

Dimensions

SIZE	CHANNEL	STOCK CODE	K	L*	M**	N	P	Q	R	S	T	U	RECOMMENDED FASTENER
1	90° Vee	UTTS1	1.024 [26.00]	141.732 ± .079 Max. [3600 ± 2 Max.]	Use Formula on Page 19 to Calculate	3.150 [80.00]	.228 [5.79]	.393 [9.98]	.110 [2.79]	.512 [13.00]	.158 [4.00]	.591 [15.00]	M5 Low Head Cap Screw
	Crown	UTTRS1	1.024 [26.00]	141.732 ± .079 Max. [3600 ± 2 Max.]		3.150 [80.00]	.228 [5.79]	.393 [9.98]	.110 [2.79]	.512 [13.00]	.158 [4.00]	.591 [15.00]	
2	90° Vee	UTTS2	1.575 [40.00]	141.732 ± .079 Max. [3600 ± 2 Max.]	Custom End Spacing Possible (9.0 to 72.0 mm)	3.150 [80.00]	.347 [8.81]	.561 [14.25]	.120 [3.05]	.788 [20.00]	.177 [4.50]	.777 [19.74]	M8 Low Head Cap Screw
	Crown	UTTRS2	1.575 [40.00]	141.732 ± .079 Max. [3600 ± 2 Max.]		3.150 [80.00]	.347 [8.81]	.561 [14.25]	.120 [3.05]	.788 [20.00]	.177 [4.50]	.777 [19.74]	
3	90° Vee	UTTS3	2.284 [58.00]	141.732 ± .079 Max. [3600 ± 2 Max.]	Custom End Spacing Possible (9.0 to 72.0 mm)	3.150 [80.00]	.347 [8.81]	.561 [14.25]	.197 [5.00]	1.142 [29.00]	.315 [8.00]	1.180 [29.97]	M8 Low Head Cap Screw
	Crown	UTTRS3	2.284 [58.00]	141.732 ± .079 Max. [3600 ± 2 Max.]		3.150 [80.00]	.347 [8.81]	.561 [14.25]	.197 [5.00]	1.142 [29.00]	.315 [8.00]	1.180 [29.97]	

*Standard cut-to-length tolerance +/- 0.06" [1.524 mm]

**Hole end spacing tolerance +/- 0.03" [0.762 mm]

3 Wheel Plate

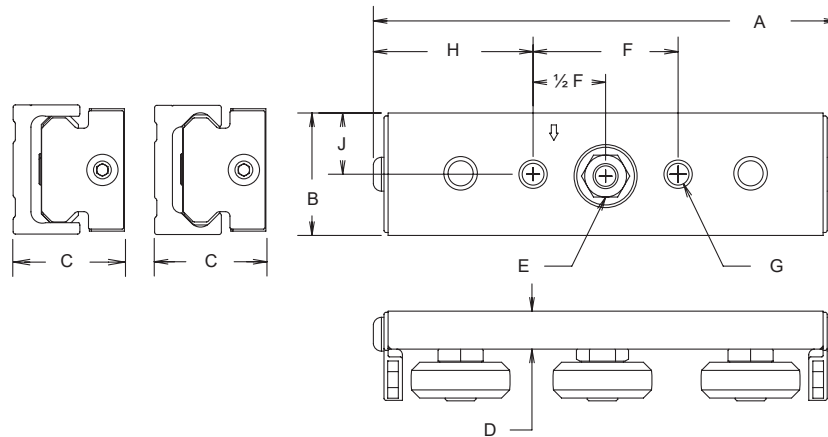

Dimensions

SIZE	WHEEL STYLE	STOCK CODE	# WHEELS	A	B	C (IN VEE CHANNEL)	C (IN C CHANNEL)	D	E*	F	G	H	J	WHEEL WRENCH
1	90° Vee/ Crown	UTVC1XWPA	3	4.467 [113.46]	.945 [24.00]	1.036 [26.31]	1.024 - 1.087 [26.00 - 27.61]	.347 [8.81]	10MM SOCKET	.1575 [40.00]	M6 X 1.0	1.446 [36.73]	.472 [12.00]	BAW1
2	90° Vee/ Crown	UTVC2XWPA	3	5.675 [144.15]	1.496 [38.00]	1.377 [34.98]	1.366 - 1.472 [34.70 - 37.39]	.464 [11.79]	13MM SOCKET	1.772 [45.00]	M8 X 1.25	1.952 [49.58]	.748 [19.00]	BAW2
3	90° Vee/ Crown	UTVC3XWPA	3	7.926 [201.32]	2.165 [55.00]	1.968 [50.00]	1.846 - 2.102 [46.89 - 53.40]	.620 [15.75]	15MM SOCKET*	2.362 [60.00]	M10 X 1.5	2.782 [70.66]	1.083 [27.50]	BAW3

Dimensions are shown in inch and [millimeter] values

Wheel plate is representative of both DualVee wheels and MadeWell crown rollers
Drawings are not to scale

*Size 3 wheel plate assemblies with vibration-resistant lock nuts ("WPLA" in stock code) use 17MM SOCKET

VC SERIES

4 and 5 Wheel Plate

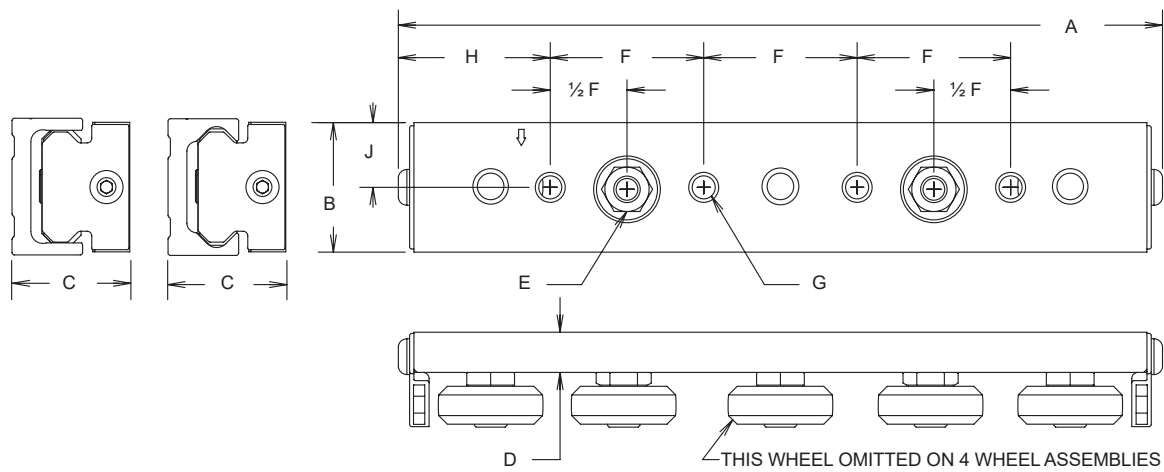

Dimensions

SIZE	WHEEL STYLE	STOCK CODE	# WHEELS	A	B	C (IN VEE CHANNEL)	C (IN C CHANNEL)	D	E*	F	G	H	J	K	WHEEL WRENCH
1	90° Vee/ Crown	UTVC1XWPA4	4	6.553 [166.45]	.945 [24.00]	1.036 [26.31]	1.024 - 1.087 [26.00 - 27.61]	.347 [8.81]	10MM SOCKET	1.378 [35.00]	M6 X 1.0	1.210 [30.73]	.472 [12.00]	.807 [20.50]	BAW1
		UTVC1XWPA5	5	6.553 [166.45]	.945 [24.00]	1.036 [26.31]	1.024 - 1.087 [26.00 - 27.61]	.347 [8.81]	10MM SOCKET	1.378 [35.00]	M6 X 1.0	1.210 [30.73]	.472 [12.00]	.807 [20.50]	
2	90° Vee/ Crown	UTVC2XWPA4	4	8.852 [224.16]	1.496 [38.00]	1.377 [34.98]	1.366 - 1.472 [34.70 - 37.39]	.464 [11.79]	13MM SOCKET	1.772 [45.00]	M8 X 1.25	1.755 [44.56]	.748 [19.00]	.886 [22.50]	BAW2
		UTVC2XWPA5	5	8.852 [224.16]	1.496 [38.00]	1.377 [34.98]	1.366 - 1.472 [34.70 - 37.39]	.464 [11.79]	13MM SOCKET	1.772 [45.00]	M8 X 1.25	1.755 [44.56]	.748 [19.00]	.886 [22.50]	
3	90° Vee/ Crown	UTVC3XWPA4	4	12.493 [317.32]	2.165 [55.00]	1.968 [50.00]	1.846 - 2.102 [46.89 - 53.40]	.620 [15.75]	15MM SOCKET*	2.362 [60.00]	M10 X 1.5	2.704 [68.68]	1.083 [27.50]	1.181 [30.00]	BAW3
		UTVC3XWPA5	5	12.493 [317.32]	2.165 [55.00]	1.968 [50.00]	1.846 - 2.102 [46.89 - 53.40]	.620 [15.75]	15MM SOCKET*	2.362 [60.00]	M10 X 1.5	2.704 [68.68]	1.083 [27.50]	1.181 [30.00]	

Dimensions are shown in inch and [millimeter] values
 Wheel plate is representative of both DualVee wheels and MadeWell crown rollers
 Drawings are not to scale

*Size 3 wheel plate assemblies with vibration-resistant lock nuts ("WPLA" in stock code) use 17MM SOCKET

CR SERIES

The UtiliTrak® CR Series has been designed and engineered as a corrosion resistant stainless steel guide wheel plate paired with composite channel with aluminum base and polished stainless steel track. It is ideal for medium to heavy duty transport applications where corrosion resistance is required.

Design Benefits

- Medium to heavy duty applications
- Ease of installation
- Corrosion resistant
- Food processing compatible and meets FDA standard
- High speed capacity
- Very low rolling friction operation
- Low noise
- Eccentric bearing for easy wheel plate adjustment
- Butt-joining precision ground channel for unlimited travel lengths

Key Industries

- Food Processing
- Vertical Farming
- Nuclear
- Cutting

Application Examples

- Chicken cutting, slicing, and processing with regular chemical washdowns
- Automated or manual pool cover
- Chemical dipping & coating
- Envelope accumulator

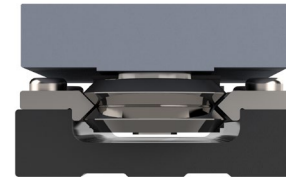

Vee Wheel

		CR Series
		90° VEE
OVERVIEW	<i>Compatible Channel</i>	90° Vee
	<i>Compatible Wheel Plate</i>	90° Vee
	<i>Loading Direction</i>	Axial and Radial
	<i>Optional Brake</i>	Not Available
	<i>Available Sizes</i>	1, 2, 3
CHANNEL	<i>Material(s)</i>	Stainless Steel and Aluminum
	<i>Standard Coating(s)</i>	Clear Anodized Base, Oiled Channel
	<i>Hardened</i>	Yes
	<i>Finish</i>	Polished
WHEEL PLATE	<i># of Wheels</i>	3
	<i>Bearing</i>	Double Row Angular Contact
	<i>Wheel Material</i>	Stainless Steel
	<i>Wheel Material Grade</i>	440C
	<i>Max. Angular Misalignment</i>	0°
	<i>Wheel Bottom Hex Feature</i>	Not Available
	<i>Preloaded Adjustment Hex</i>	Metric
	<i>Lubrications</i>	Stamped Stainless Steel Center Mounted
	<i>Wheel Protection</i>	Sealed Seal/Shield
	<i>Wheel Versions</i>	Corrosion Resistant

For instructions regarding mounting and orientation, life estimation, preloading, and maintenance, see the UtiliTrak section of the Technical Data catalog.

CR SERIES

Application Examples

Envelope Sorter

The UtiliTrak® CR Series linear guides are available with long single-piece channel lengths that are ideal for bulk processing and production equipment. This machine uses a parallel pair of CR series linear guides to control the outflow of envelopes and paper products.

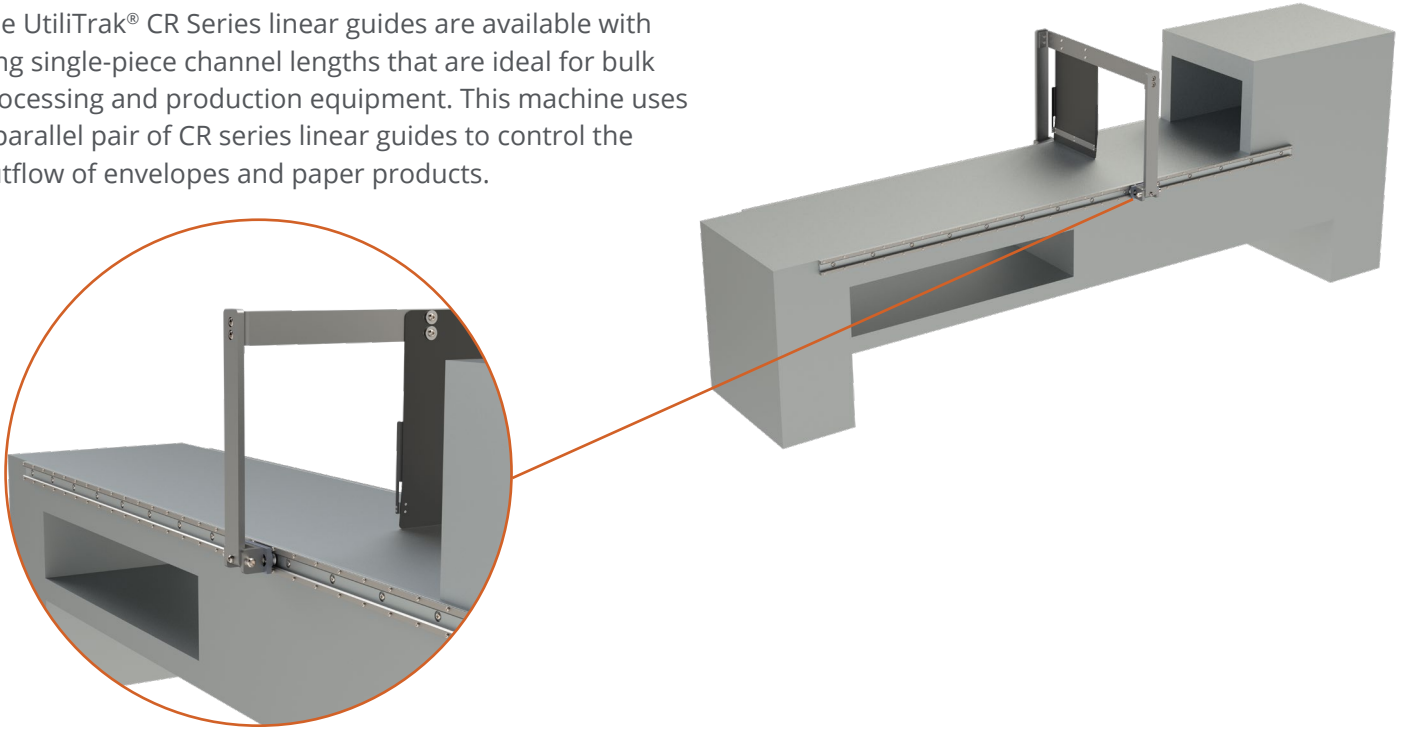

Chemical Dipping

UtiliTrak® CR Series with corrosion resistant stainless steel components is used as a linear guide for supporting fragile but heavy loads as they are lowered into a barrel of chemicals for a treatment process.



CR SERIES

Wheel Plate Max Load Capacity

See the Technical Data catalog page 24 - 26 for sizing/selection and life estimation.

	WHEEL SIZE	STOCK CODE	MASS (G)	RADIAL L_R		AXIAL L_A		PITCH M_p		YAW M_y		ROLL M_r	
				(N)	(LBF)	(N)	(LBF)	(N-M)	(LBF-FT)	(N-M)	(LBF-FT)	(N-M)	(LBF-FT)
STAINLESS STEEL	1	UTCCA1-SS	136	2440	549	719	162	18	13.3	30.5	22.5	7.0	5.2
	2	UTCCA2-SS	385	5300	1191	1475	332	58	42.8	100	73.8	22.7	16.7
	3	UTCCA3-SS	1107	11800	2653	5100	1147	229	168.9	346	255.2	118	87
STAINLESS HIGH TEMP	1	UTCCA1-227	136	1952	439	575	129	14.4	10.6	24.4	18	5.6	4.1
	2	UTCCA2-227	385	4240	953	1180	265	46.4	34.2	80	59	18.2	13.4
	3	UTCCA3-227	1107	9440	2122	4080	917	183.2	135.2	276.8	204.3	94.4	69.7

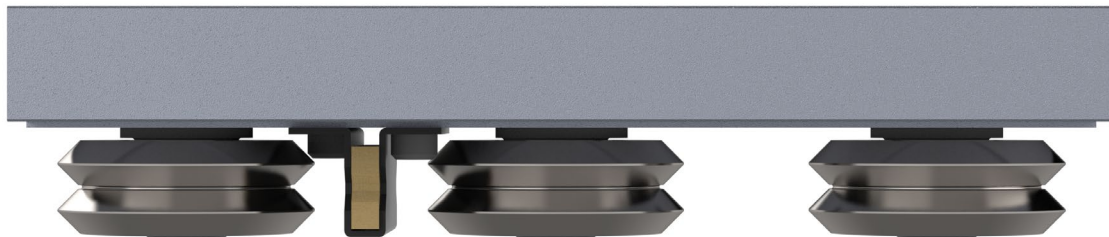

Track Channel (Composite Assembly): Clear Anodized Aluminum Base with Polished Stainless Steel Track

90° Vee

UTCOMP1SS - (Channel length in mm)

UTCOMP2SS - (Channel length in mm)

UTCOMP3SS - (Channel length in mm)

Example: UTCOMP2SS 1.440

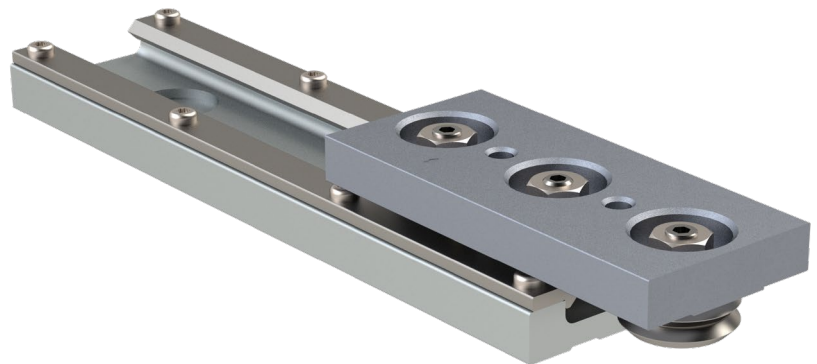

Dimensions:

CR STANDARD CHANNEL LENGTH (MM)													
Size 0	N/A	N/A	N/A	N/A	N/A	N/A	N/A	N/A	N/A	N/A	N/A	N/A	N/A
Size 1	190	290	390	490	590	690	790	890	990	1090	2990	3490	N/A
Size 2	240	390	540	690	840	990	1140	1290	1440	1590	2190	2790	3390
Size 3	415	665	915	1165	1415	1665	1915	2165	2415	2665	2915	3165	3415

Channel lengths come in stock lengths and are customizable by application.
Butt-joining channel for unlimited travel lengths.

CR SERIES

Channel

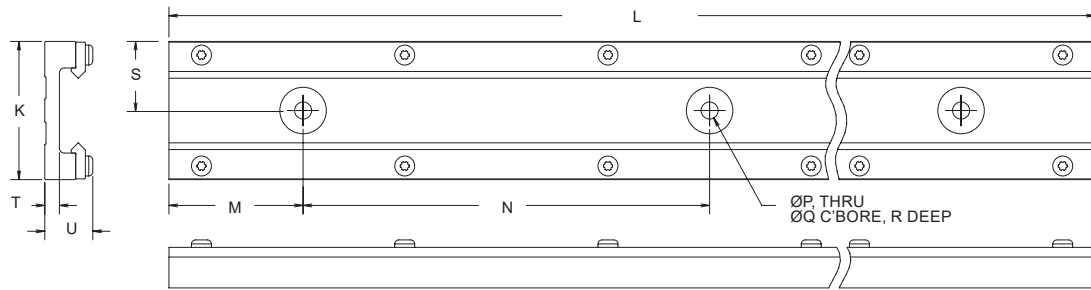

Dimensions

SIZE	CHANNEL	STOCK CODE	K	L	M	N	P	Q	R	S	T	U	RECOMMENDED FASTENER
1	90° Vee	UTCOMP1SS	1.575 [40.00]	137.402 ± .079 Max. [3495 ± 2 Max.]	1.771 [45.00]	3.937 [100.00]	.272 [6.91]	.740 [18.80]	.079 [2.00]	.788 [20.00]	.232 [5.89]	.697 [17.70]	M6 Pan Head Screw
2	90° Vee	UTCOMP2SS	2.362 [60.00]	133.465 ± .079 Max. [3390 ± 2 Max.]	1.771 [45.00]	5.906 [150.00]	.346 [8.79]	1.000 [25.40]	.118 [3.00]	1.181 [30.00]	.287 [7.29]	.839 [21.31]	M8 Pan Head Screw
3	90° Vee	UTCOMP3SS	3.346 [85.00]	134.449 ± .079 Max. [3415 ± 2 Max.]	3.249 [82.52]	9.843 [250.00]	.413 [10.49]	1.125 [28.58]	1.97 [5.00]	1.673 [42.50]	.354 [9.00]	1.162 [29.52]	M10 Pan Head Screw

3 Wheel Plate

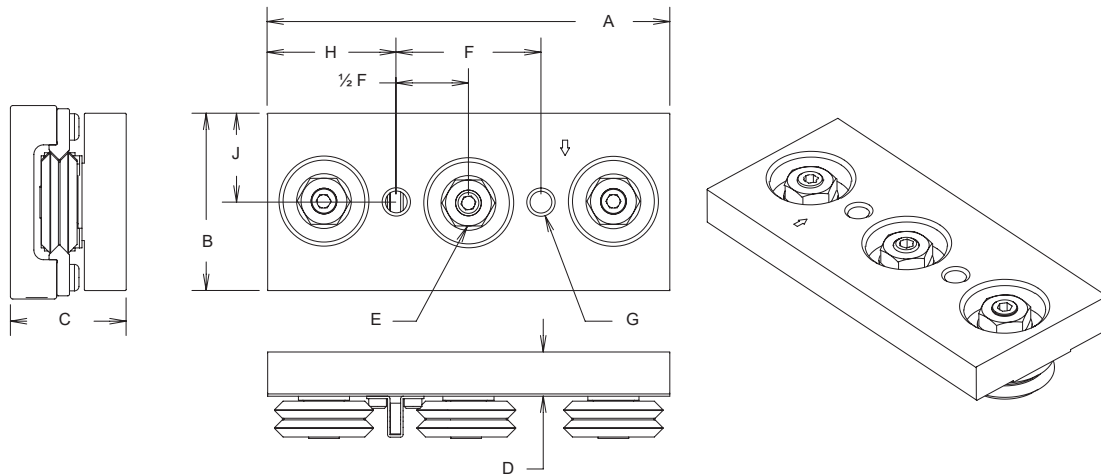

Dimensions

SIZE	WHEEL STYLE	STOCK CODE	# WHEELS	A	B	C	D	E	F	G	H	J	WHEEL WRENCH
1	Stainless Steel	UTCCA1-SS	3	3.940 [100.00]	1.496 [38.00]	1.102 [28.00]	.398 [10.11]	7MM SOCKET	1.575 [40.00]	M6 X 1.0	1.183 [30.05]	.748 [19.00]	1.5 mm Hex
	High Temperature Stainless Steel	UTCCA1-227	3	3.940 [100.00]	1.496 [38.00]	1.102 [28.00]	.398 [10.11]	7MM SOCKET	1.575 [40.00]	M6 X 1.0	1.183 [30.05]	.748 [19.00]	
2	Stainless Steel	UTCCA2-SS	3	4.920 [125.00]	2.165 [55.00]	1.417 [36.00]	.540 [13.72]	13MM SOCKET	1.772 [45.00]	M8 X 1.25	1.575 [40.00]	1.083 [27.50]	4 mm Hex
	High Temperature Stainless Steel	UTCCA2-227	3	4.920 [125.00]	2.165 [55.00]	1.417 [36.00]	.540 [13.72]	13MM SOCKET	1.772 [45.00]	M8 X 1.25	1.575 [40.00]	1.083 [27.50]	
3	Stainless Steel	UTCCA3-SS	3	6.690 [170.00]	3.150 [80.00]	1.968 [50.00]	.772 [19.61]	17MM SOCKET	2.362 [60.00]	M10 X 1.5	2.164 [55.00]	1.575 [40.00]	5 mm Hex
	High Temperature Stainless Steel	UTCCA3-227	3	6.690 [170.00]	3.150 [80.00]	1.968 [50.00]	.772 [19.61]	17MM SOCKET	2.362 [60.00]	M10 X 1.5	2.164 [55.00]	1.575 [40.00]	

Dimensions are shown in inches and [millimeters]
Drawings are not to scale

ACCESSORIES

Flat Wrench for Eccentric Wheel Adjustment

- Adjusting the wheel plate fit and running feel requires a socket wrench and an open-end flat wrench (SW/PW/VC)
- Instructions for preloading and adjustment can be found in the UtiliTrak section of the Technical Data Catalog

FLAT WRENCH	SIZE	STOCK CODE	A	B	C	D (MM)	E (INCH)
	0	BAW0	5.00 [127]	1.25 [31.75]	0.075 [1.9]	11	3/8
	1	BAW1	7.00 [177.8]	1.50 [38.1]	0.075 [1.9]	12	7/16
	2	BAW2	8.00 [203.2]	1.75 [44.5]	0.105 [2.7]	14	9/16
	3	BAW3	9.00 [228.6]	2.00 [50.8]	0.135 [3.4]	19	3/4

Dimensions are shown in inches and [millimeters] unless otherwise specified. Drawings are not to scale

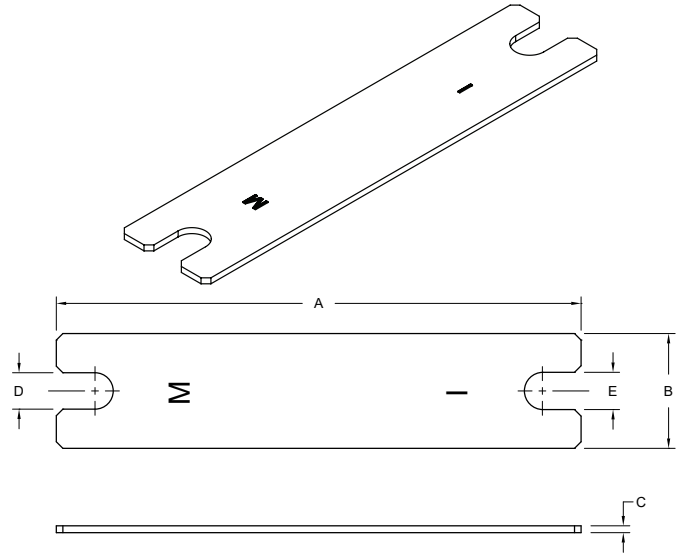

Brake Kit for Wheel Plates

- Compact system ideal for applications where handle arm access space is limited
- Brake system allows steel (VC and SW series) and aluminum (PW series) UtiliTrak® wheel plates to be manually locked at any user-selected position on vee and C channel
- Brake block fabricated from aluminum and hard anodized for corrosion resistance, abrasion resistance, good gripping/braking action, and long life

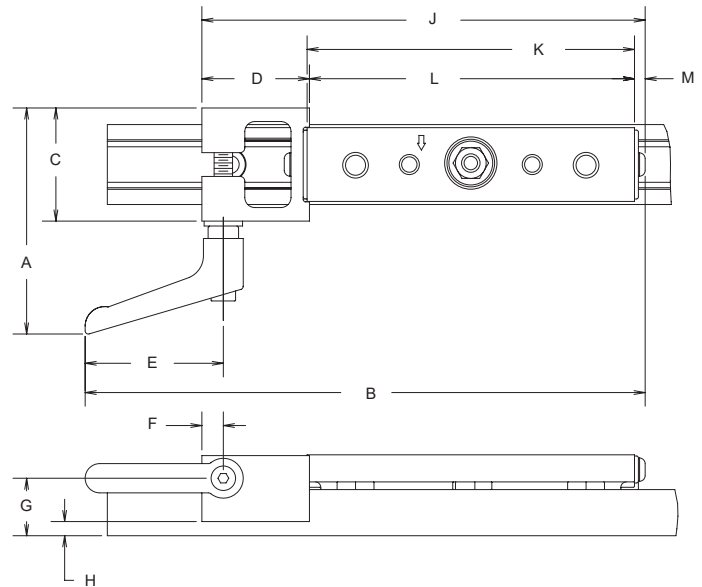
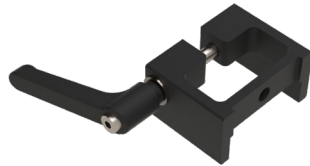

HAND BRAKE	SIZE	STOCK CODE	MASS (G)
	0	UT0BRKCLMPK	45
	1	UT1BRKCLMPK	54
	2	UT2BRKCLMPK	77
	3	UT3BRKCLMPK	181

Dimensions

SIZE	STOCK CODE	A	B	C	D	E	F	G	H	J	K	L	M
0	UT0BRKCLMPK	2.488 [63.2]	5.675 [144.2]	1.042 [26.5]	1.181 [30.0]	1.770 [45.0]	.275 [7.0]	.607 [15.4]	.032 [0.8]	4.180 [106.2]	2.914 [74.0]	2.884 [73.3]	.155 [2.9]
1	UT1BRKCLMPK	2.895 [73.5]	7.174 [182.2]	1.449 [36.8]	1.378 [35.0]	1.770 [45.0]	.275 [7.0]	.736 [18.7]	.181 [4.6]	5.679 [144.2]	4.194 [106.5]	4.164 [105.8]	.137 [3.5]
2	UT2BRKCLMPK	3.450 [87.6]	8.535 [216.8]	2.004 [50.9]	1.575 [40.0]	1.770 [45.0]	.275 [7.0]	1.052 [26.7]	.367 [9.3]	7.040 [178.8]	5/315 [135.0]	5.285 [134.2]	.180 [4.6]
3	UT3BRKCLMPK	4.466 [113.4]	11.925 [303.0]	2.617 [66.5]	2.205 [56.0]	2.480 [63.0]	.433 [11.0]	1.488 [37.8]	.706 [17.9]	9.878 [250.9]	7.480 [190.0]	7.450 [189.2]	.223 [5.7]

Dimensions are shown in inches and [millimeters] unless otherwise specified. Drawings are not to scale.

ACCESSORIES

Bridge Kit

- Includes fasteners and brackets to mount bridge element to UtiliTrak® wheel plates
- UtiliTrak® wheel plates and channel are sold separately
- Custom machining on bridge available
- Carbon steel bridge does not include mounting holes

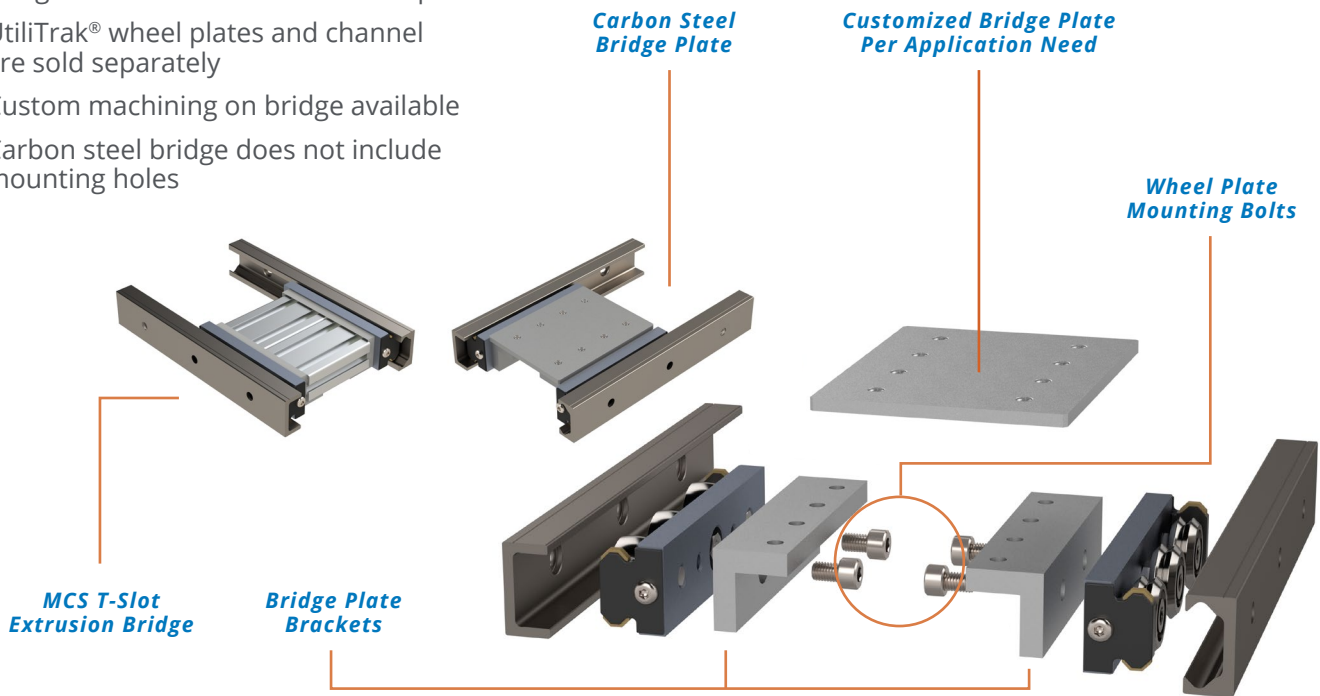

BRIDGE KITS	WHEEL PLATE SIZE	WHEEL COUNT	CHANNEL SPAN WIDTH RANGE (MM)	BRIDGE ELEMENT TYPE	STOCK CODE
	0	3	125 to 200	Carbon Steel Plate	UT0BPB3Knnnn.n*
				MCS T-Slot Extrusion	UT0BEB3Knnnn.n*
	4 or 5	125 to 300	Carbon Steel Plate	UT0BPB5Knnnn.n*	
			MCS T-Slot Extrusion	UT0BEB5Knnnn.n*	
	1	3	150 to 300	Carbon Steel Plate	UT1BPB3Knnnn.n*
				MCS T-Slot Extrusion	UT1BEB3Knnnn.n*
	4 or 5	150 to 450	Carbon Steel Plate	UT1BPB5Knnnn.n*	
			MCS T-Slot Extrusion	UT1BEB5Knnnn.n*	
	2	3	150 to 375	Carbon Steel Plate	UT2BPB3Knnnn.n*
MCS T-Slot Extrusion				UT2BEB3Knnnn.n*	
4 or 5	150 to 600	Carbon Steel Plate	UT2BPB5Knnnn.n*		
		MCS T-Slot Extrusion	UT2BEB5Knnnn.n*		
3	3	225 to 500	Carbon Steel Plate	UT3BPB3Knnnn.n*	
			MCS T-Slot Extrusion	UT3BEB3Knnnn.n*	
4 or 5	225 to 1000	Carbon Steel Plate	UT3BPB5Knnnn.n*		
		MCS T-Slot Extrusion	UT3BEB5Knnnn.n*		

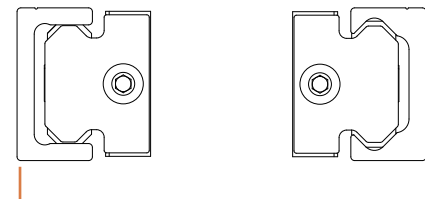
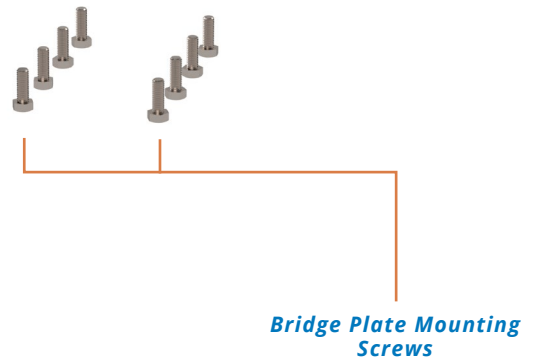

Channel Span Width

*nnnn.n is the channel span width in mm. See page 30-1.

ACCESSORIES

Bridge Brackets - 3 Wheel Plate

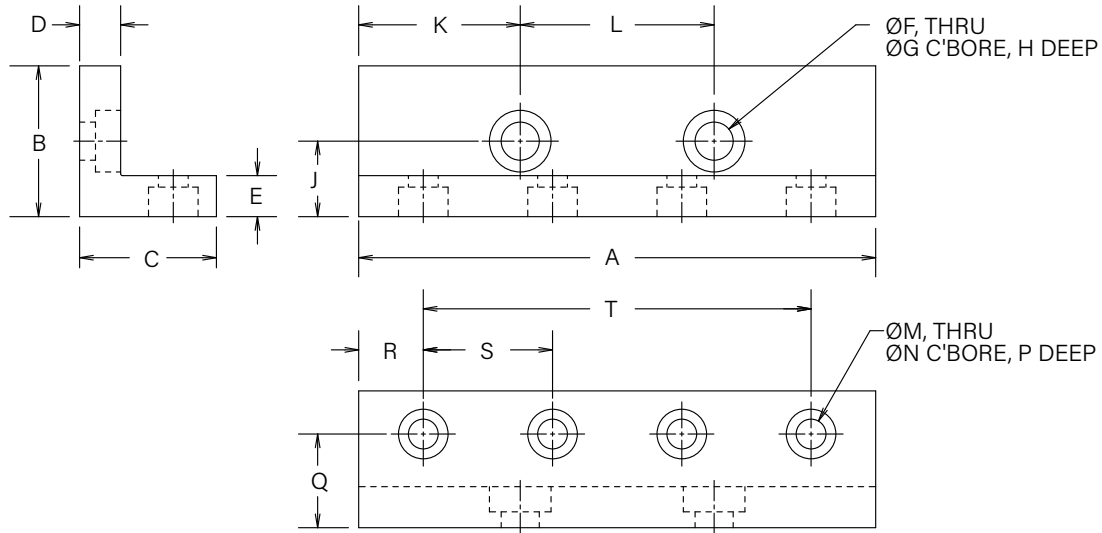

Dimensions

T-SLOT EXTRUSION

SIZE	STOCK CODE	A	B	C	D	E	F	G	H	J	K	L	M	N	P	Q	R	S	T
0	UT0BEB3	3.150 [80.01]	.730 [18.54]	.980 [24.89]	.188 [4.76]	.188 [4.76]	.189 [4.80]	.328 [8.33]	.120 [3.05]	.385 [9.78]	1.142 [29.01]	.866 [22.00]	.189 [4.80]	.328 [8.33]	.126 [3.20]	.626 [15.90]	.394 [10.01]	.787 [20.00]	2.362 [60.00]
1	UT1BEB3	3.150 [80.01]	.906 [23.01]	.980 [24.89]	.250 [6.35]	.250 [6.35]	.272 [6.91]	.450 [11.43]	.180 [4.57]	.506 [12.85]	.788 [20.02]	1.575 [40.00]	.189 [4.80]	.328 [8.33]	.190 [4.83]	.685 [17.40]	.394 [10.01]	.787 [20.00]	2.362 [60.00]
2	UT2BEB3	4.724 [199.99]	1.378 [35.00]	1.230 [31.24]	.375 [9.53]	.375 [9.53]	.348 [8.84]	.563 [14.30]	.230 [5.84]	.709 [18.01]	1.476 [37.49]	1.772 [45.00]	.272 [6.91]	.453 [11.51]	.270 [6.86]	.866 [22.00]	.590 [14.99]	1.181 [30.00]	3.543 [90.00]
3	UT3BEB3	6.300 [160.02]	1.811 [46.00]	1.980 [50.29]	.500 [12.70]	.500 [12.70]	.425 [10.80]	.688 [17.48]	.400 [10.16]	.920 [23.37]	1.969 [50.01]	2.362 [60.00]	.348 [8.84]	.563 [14.30]	.330 [8.38]	1.181 [30.00]	.788 [20.01]	1.575 [40.00]	4.724 [120.00]

Dimensions

STEEL PLATE

SIZE	STOCK CODE	A	B	C	D	E	F	G	H	J	K	L	M	N	P	Q	R	S	T
0	UT0BPB3	3.150 [80.01]	.730 [18.54]	.980 [24.89]	.188 [4.76]	.188 [4.76]	.189 [4.80]	.328 [8.33]	.120 [3.05]	.385 [9.78]	1.142 [29.01]	.866 [22.00]	.189 [4.80]	N/A	N/A	.626 [15.90]	.394 [10.01]	.787 [20.00]	2.362 [60.00]
1	UT1BPB3	3.150 [80.01]	.906 [23.01]	.980 [24.89]	.250 [6.35]	.250 [6.35]	.272 [6.91]	.450 [11.43]	.180 [4.57]	.506 [12.85]	.788 [20.02]	1.575 [40.00]	.189 [4.80]	N/A	N/A	.685 [17.40]	.394 [10.01]	.787 [20.00]	2.362 [60.00]
2	UT2BPB3	4.724 [199.99]	1.378 [35.00]	1.230 [31.24]	.375 [9.53]	.375 [9.53]	.348 [8.84]	.563 [14.30]	.230 [5.84]	.709 [18.01]	1.476 [37.49]	1.772 [45.00]	.272 [6.91]	N/A	N/A	.866 [22.00]	.590 [14.99]	1.181 [30.00]	3.543 [90.00]
3	UT3BPB3	6.300 [160.02]	1.811 [46.00]	1.980 [50.29]	.500 [12.70]	.500 [12.70]	.425 [10.80]	.688 [17.48]	.400 [10.16]	.920 [23.37]	1.969 [50.01]	2.362 [60.00]	.348 [8.84]	N/A	N/A	1.181 [30.00]	.788 [20.01]	1.575 [40.00]	4.724 [120.00]

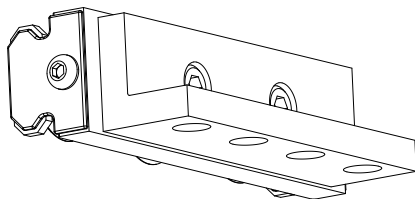

**Brackets for T-Slot Extrusion
Have Counterbored Thru Holes**

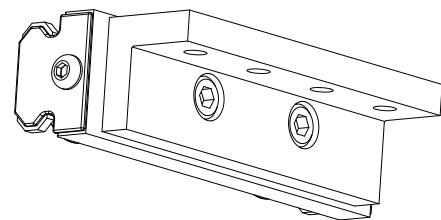

**Brackets for Steel Plate
Have Thru Holes**

Dimensions are shown in inches and [millimeters]
Drawings are not to scale

ACCESSORIES

Bridge Brackets - 4 and 5 Wheel Plate

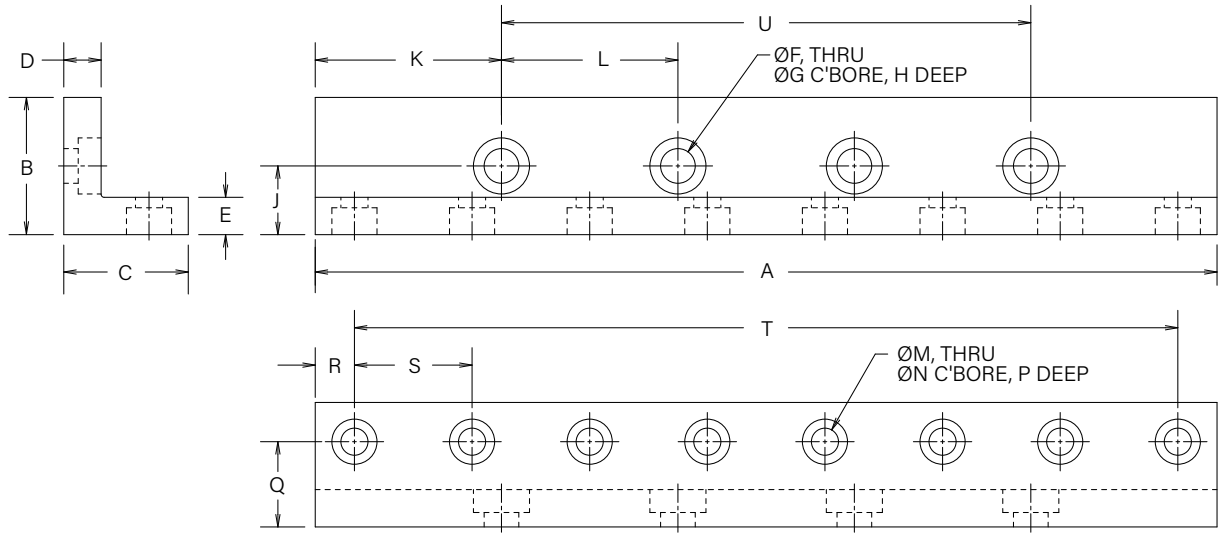

Dimensions

T-SLOT EXTRUSION

SIZE	STOCK CODE	A	B	C	D	E	F	G	H	J	K	L	# OF HOLES	M	N	P	Q	R	S	T	U
0	UT0BEB5	4.528 [115.01]	.730 [18.54]	.980 [24.89]	.188 [4.76]	.188 [4.76]	.189 [4.80]	.328 [8.33]	.120 [3.05]	.385 [9.78]	.965 [24.51]	.866 [22.00]	6	.189 [4.80]	.328 [8.33]	.126 [3.20]	.626 [15.90]	.296 [7.52]	.787 [20.00]	3.937 [100.00]	2.598 [66.00]
1	UT1BEB5	6.300 [160.02]	.906 [23.01]	.980 [24.89]	.250 [6.35]	.250 [6.35]	.272 [6.91]	.450 [11.43]	.180 [4.57]	.506 [12.85]	1.083 [27.51]	1.378 [35.00]	8	.189 [4.80]	.328 [8.33]	.190 [4.83]	.685 [17.40]	.394 [10.01]	.787 [20.00]	5.512 [140.00]	4.134 [105.00]
2	UT2BEB4	9.055 [230.00]	1.378 [35.00]	1.230 [31.24]	.375 [9.53]	.375 [9.53]	.348 [8.84]	.563 [14.30]	.230 [5.84]	.709 [18.01]	1.870 [47.50]	1.772 [45.00]	8	.272 [6.91]	.453 [11.51]	.270 [6.86]	.866 [22.00]	.394 [10.01]	1.181 [30.00]	8.268 [210.00]	5.315 [135.00]
3	UT3BEB5	12.205 [310.01]	1.811 [46.00]	1.980 [50.29]	.500 [12.70]	.500 [12.70]	.425 [10.80]	.688 [17.48]	.400 [10.16]	.920 [23.37]	2.559 [65.00]	2.362 [60.00]	8	.348 [8.84]	.563 [14.30]	.330 [8.38]	1.181 [30.00]	.591 [15.00]	1.575 [40.00]	11.024 [280.00]	7.087 [180.00]

Dimensions

STEEL PLATE

SIZE	STOCK CODE	A	B	C	D	E	F	G	H	J	K	L	# OF HOLES	M	N	P	Q	R	S	T	U
0	UT0BPP5	4.528 [115.01]	.730 [18.54]	.980 [24.89]	.188 [4.76]	.188 [4.76]	.189 [4.80]	.328 [8.33]	.120 [3.05]	.385 [9.78]	.965 [24.51]	.866 [22.00]	6	.189 [4.80]	N/A	N/A	.626 [15.90]	.296 [7.52]	.787 [20.00]	3.937 [100.00]	2.598 [66.00]
1	UT1BPP5	6.300 [160.02]	.906 [23.01]	.980 [24.89]	.250 [6.35]	.250 [6.35]	.272 [6.91]	.450 [11.43]	.180 [4.57]	.506 [12.85]	1.083 [27.51]	1.378 [35.00]	8	.189 [4.80]	N/A	N/A	.685 [17.40]	.394 [10.01]	.787 [20.00]	5.512 [140.00]	4.134 [105.00]
2	UT2BPP5	9.055 [230.00]	1.378 [35.00]	1.230 [31.24]	.375 [9.53]	.375 [9.53]	.348 [8.84]	.563 [14.30]	.230 [5.84]	.709 [18.01]	1.870 [47.50]	1.772 [45.00]	8	.272 [6.91]	N/A	N/A	.866 [22.00]	.394 [10.01]	1.181 [30.00]	8.268 [210.00]	5.315 [135.00]
3	UT3BPP5	12.205 [310.01]	1.811 [46.00]	1.980 [50.29]	.500 [12.70]	.500 [12.70]	.425 [10.80]	.688 [17.48]	.400 [10.16]	.920 [23.37]	2.559 [65.00]	2.362 [60.00]	8	.348 [8.84]	N/A	N/A	1.181 [30.00]	.591 [15.00]	1.575 [40.00]	11.024 [280.00]	7.087 [180.00]

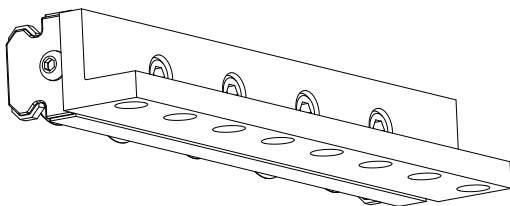

**Brackets for T-Slot Extrusion
Have Counterbored Thru Holes**

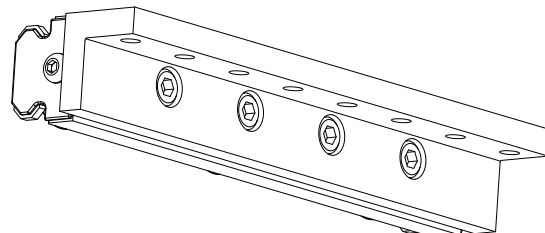

**Brackets for Steel Plate
Have Thru Holes**

Dimensions are shown in inches and [millimeters]
Drawings are not to scale

ACCESSORIES

Bridge Kit - T-Slot Extrusion

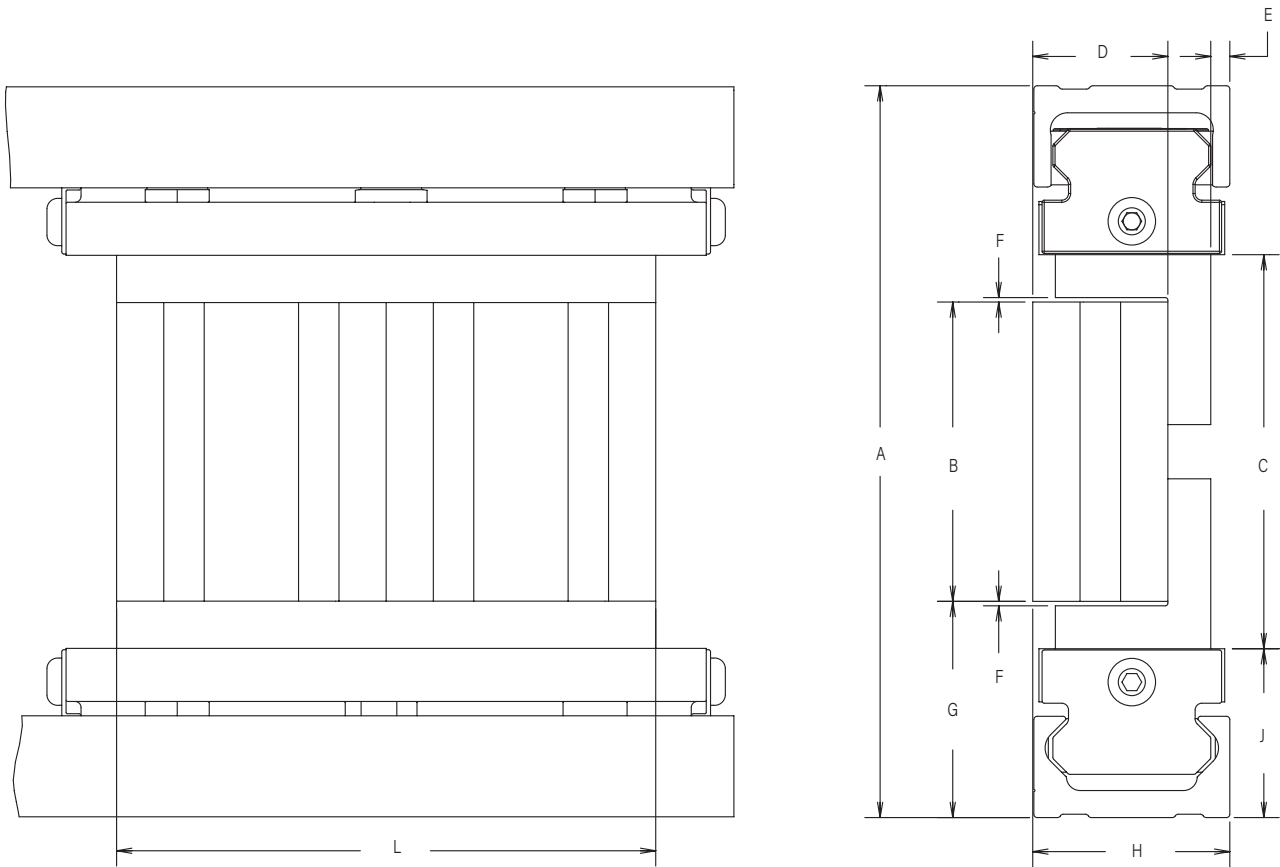

Dimensions

T-SLOT EXTRUSION											
SIZE	STOCK CODE	A	B	C	D	E	F	G	H	J	L
0	UT0BE3Knnnn.n*	Channel Span Width	Dim. A - 2.205 [56.00]	Dim. A - 1.732 [44.00]	.787 [20.00]	.009 [0.23]	.048 [1.21]	1.102 [28.00]	.984 [25.00]	.867 [22.02]	3.150 [80.00]
	UT0BE5Knnnn.n*		Dim. A - 2.205 [56.00]	Dim. A - 1.732 [44.00]	.787 [20.00]	.009 [0.23]	.048 [1.21]	1.102 [28.00]	.984 [25.00]	.867 [22.02]	4.724 [120.00]
1	UT1BE3Knnnn.n*		Dim. A - 2.677 [68.00]	Dim. A - 2.071 [52.60]	.787 [20.00]	.006 [0.15]	.053 [1.35]	1.340 [34.02]	1.048 [26.49]	1.036 [22.02]	3.150 [80.00]
	UT1BE5Knnnn.n*		Dim. A - 2.677 [68.00]	Dim. A - 2.071 [52.60]	.787 [20.00]	.006 [0.15]	.053 [1.35]	1.340 [34.02]	1.048 [26.49]	1.036 [22.02]	6.299 [160.00]
2	UT2BE3Knnnn.n*		Dim. A - 3.622 [92.00]	Dim. A - 2.756 [70.00]	1.181 [30.00]	0.79 [2.01]	.059 [1.50]	1.812 [46.01]	1.635 [41.53]	1.377 [34.98]	4.724 [120.00]
	UT2BE5Knnnn.n*		Dim. A - 3.622 [92.00]	Dim. A - 2.756 [70.00]	1.181 [30.00]	0.79 [2.01]	.059 [1.50]	1.812 [46.01]	1.635 [41.53]	1.377 [34.98]	9.449 [240.00]
3	UT3BE3Knnnn.n*		Dim. A - 5.039 [128.00]	Dim. A - 3.937 [100.00]	1.575 [40.00]	.222 [5.64]	.052 [1.31]	2.519 [63.98]	2.297 [58.34]	1.968 [49.99]	6.299 [160.00]
	UT3BE5Knnnn.n*		Dim. A - 5.039 [128.00]	Dim. A - 3.937 [100.00]	1.575 [40.00]	.222 [5.64]	.052 [1.31]	2.519 [63.98]	2.297 [58.34]	1.968 [49.99]	12.598 [320.00]

*nnnn.n is the channel span width in mm
 Dimensions are shown in inches and [millimeters]
 Drawings are not to scale

ACCESSORIES

Bridge Kit - 3 and 5 Steel Plate

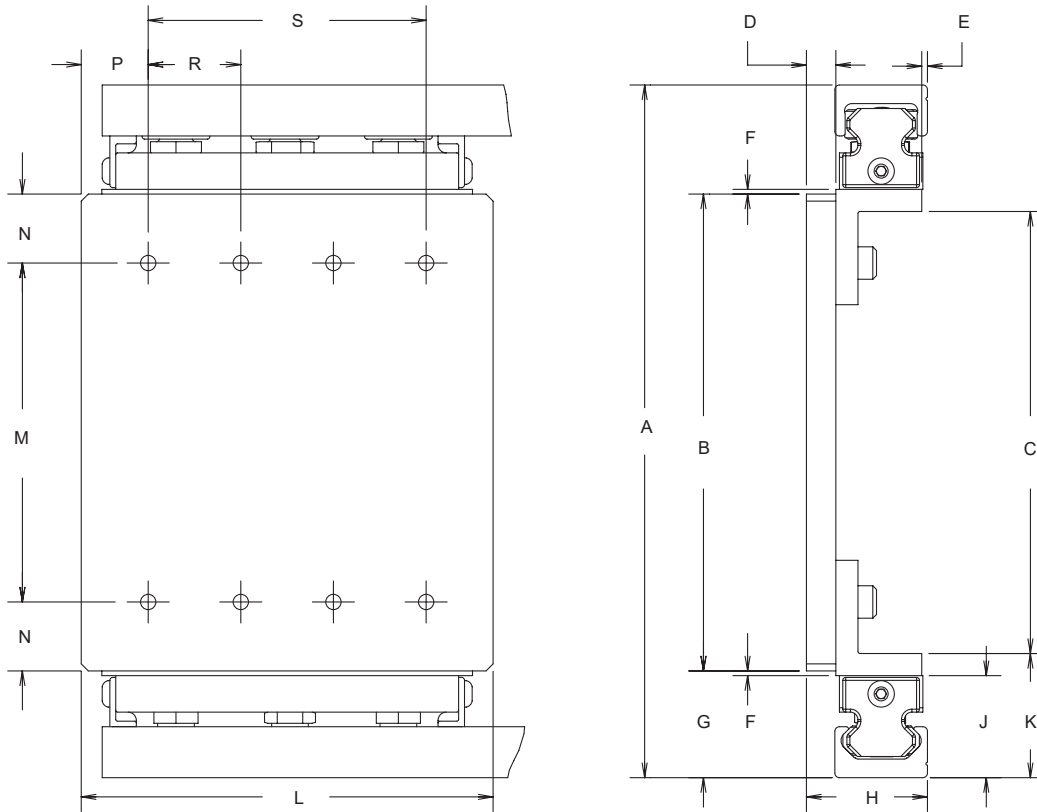

Dimensions

3 AND 5 STEEL PLATE																		
SIZE	STOCK CODE	A	B	C	D	E	F	G	H	J	K	L	M	# OF SCREWS	N	P	R	S
0	UT0BC3Knnnn.n*	Dim. A - 1.815 [46.10]	Dim. A - 2.110 [53.60]	.250 [6.35]	.049 [1.24]	.040 [1.02]	.907 [23.04]	1.029 [26.14]	.867 [22.02]	1.055 [26.80]	3.500 [88.90]	Dim A - 2.988 [75.90]	4	.586 [14.88]	.569 [14.45]	.787 [20.00]	2.362 [60.00]	
	UT0BC5Knnnn.n*	Dim. A - 1.815 [46.10]	Dim. A - 2.110 [53.60]	.250 [6.35]	.049 [1.24]	.040 [1.02]	.907 [23.04]	1.029 [26.14]	.867 [22.02]	1.055 [26.80]	4.500 [114.30]	Dim A - 2.984 [75.90]	4	.586 [14.88]	.282 [7.16]	.787 [20.00]	3.937 [100.00]	
1	UT1BC3Knnnn.n*	Dim. A - 2.130 [54.10]	Dim. A - 2.571 [65.30]	.375 [9.53]	.112 [2.84]	.029 [0.74]	1.085 [27.56]	1.393 [35.38]	1.036 [26.31]	1.286 [32.66]	3.500 [88.90]	Dim A - 3.463 [87.96]	4	.656 [16.66]	.569 [14.45]	.787 [20.00]	2.362 [60.00]	
	UT1BC5Knnnn.n*	Dim. A - 2.130 [54.10]	Dim. A - 2.571 [65.30]	.375 [9.53]	.112 [2.84]	.029 [0.74]	1.085 [27.56]	1.393 [35.38]	1.036 [26.31]	1.286 [32.66]	6.250 [158.75]	Dim A - 3.463 [87.96]	4	.656 [16.66]	.369 [9.37]	.787 [20.00]	5.512 [140.00]	
2	UT2BC3Knnnn.n*	Dim. A - 2.835 [72.00]	Dim. A - 3.504 [89.00]	.375 [9.53]	.119 [3.02]	.040 [1.02]	1.417 [35.99]	1.872 [47.55]	1.377 [34.98]	1.752 [44.51]	5.000 [127.00]	Dim A - 4.488 [114.00]	6	.826 [20.98]	.729 [18.52]	1.181 [30.00]	3.543 [90.00]	
	UT2BC5Knnnn.n*	Dim. A - 2.835 [72.00]	Dim. A - 3.504 [89.00]	.375 [9.53]	.119 [3.02]	.040 [1.02]	1.417 [35.99]	1.872 [47.55]	1.377 [34.98]	1.752 [44.51]	9.250 [234.95]	Dim A - 4.488 [114.00]	6	.826 [20.98]	.491 [12.47]	1.181 [30.00]	8.268 [210.00]	
3	UT3BC3Knnnn.n*	Dim. A - 4.016 [102.00]	Dim. A - 4.937 [125.40]	.500 [12.70]	.251 [6.38]	.040 [1.02]	2.008 [51.00]	2.562 [65.07]	1.968 [49.99]	1.968 [49.99]	6.000 [152.40]	Dim A - 6.298 [159.97]	8	1.141 [28.98]	.638 [16.21]	1.575 [40.00]	4.724 [120.00]	
	UT3BC5Knnnn.n*	Dim. A - 4.016 [102.00]	Dim. A - 4.937 [125.40]	.500 [12.70]	.251 [6.38]	.040 [1.02]	2.008 [51.00]	2.562 [65.07]	1.968 [49.99]	1.968 [49.99]	12.000 [304.80]	Dim A - 6.298 [159.97]	8	1.141 [28.98]	.488 [12.40]	1.575 [40.00]	11.024 [280.00]	

*nnnn.n is the channel span width in mm
 Dimensions are shown in inches and [millimeters]
 Drawings are not to scale

MOTION SOLUTIONS FROM BISHOP-WISECARVER ARE LIMITED ONLY BY YOUR IMAGINATION

Components & Accessories

DualVee®
MadeWell®
GV3
SL2
PRT2
HDS2
HDRT
MCS
Motor Mounts
Gantry Brackets
Wrenches

Manual Linear Guide Systems

DualVee®
UtiliTrak®
MinVee®
GV3
Simple Select®
SL2
HDS2
MHD
HTS

Actuated Linear Guide Systems

LoPro®
XLA™
ECO60™
SlickStick™
SteadyRail™
HDLS
HDCS
PDU2
DAPDU2
SBD
PSD
SDM
DLS

Rotary Guide Systems

PRT2
DTS2
DTS
DTS+
ALR
HDRT
1-Trak
GFX

Custom Solutions

Extruded Profile Guides
Custom Bearings
Custom Sub-assemblies
Engineering Services
Large Diameter Ring Guides and Track

BWC.COM

 **BISHOP
WISECARVER**
Expertly Designed, Delivered to Perform

Courtesy of Steven Engineering, Inc - (800) 258-9200 - sales@steveneng.com - www.stevenengineering.com

Contact

Phone: (925) 439-8272
Email: Sales@bwc.com

2104 Martin Way
Pittsburg, CA 94565