

GAM GCL Series

ROBOTIC CYCLOIDAL GEARBOXES

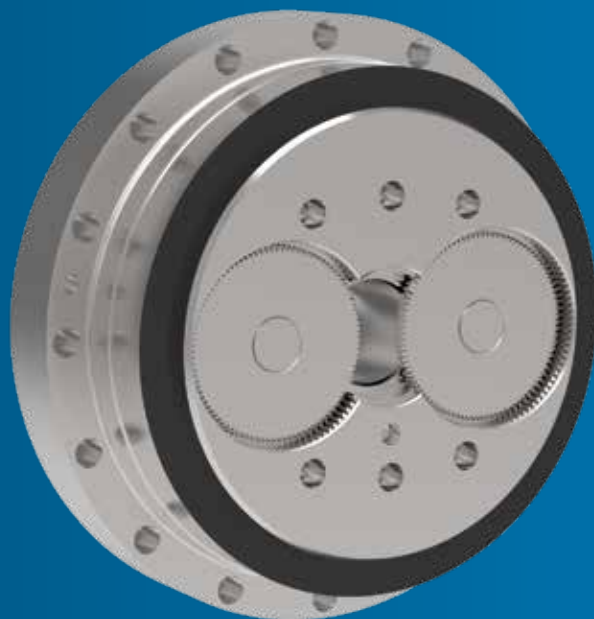

GAM CAN.

Robotic Cycloidal Gearboxes

GAM's **GCL Series Robotic Cycloidal Gearboxes** provide low backlash and high rigidity for horizontal and vertical **robotic** and **motion control** applications.



- Backlash of ≤ 1 arcmin with lost motion of ≤ 1 arcmin
- Withstands the frequent start-stop impact loads of industrial robots with impact resistance 5x nominal torque
- Multi-tooth meshing for torsional rigidity
- Planetary gear for input speed reduction
- Flange output in 7 sizes with nominal output torque of 167 to 4410 Nm and ratios of 57:1 to 192.4:1
- Flanged hollow output in 6 sizes (up to 138 mm through hole) with nominal output torque of 490 to 4900 Nm
- Drops in for many competitors' products
- Integrated motor adapter plate ready to mount your motor

Drive Sequence:

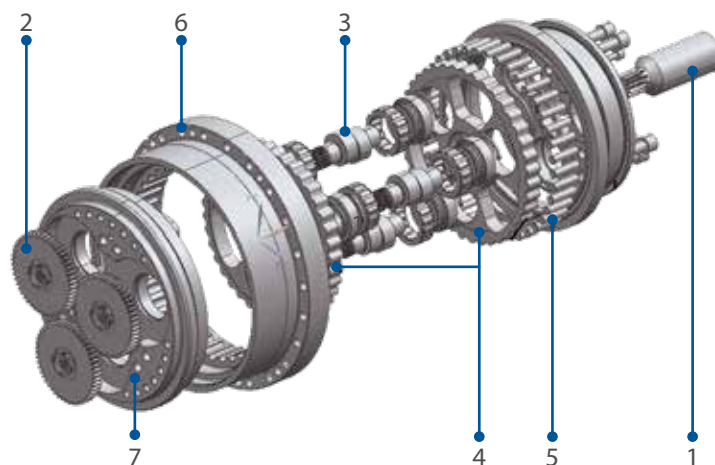

1. Input shaft/pinion
2. Planetary gears
3. Eccentric gearshafts
4. Cycloid gears
5. Pins
6. Pin Housing
7. Output

Applications

The GCL is well suited to high-end industrial robotics and motion control applications with its ability to withstand start-stop impact loads five times nominal torque.

- Robotics
- Tool changers
- Positioning
- Turntables
- Pick & Place

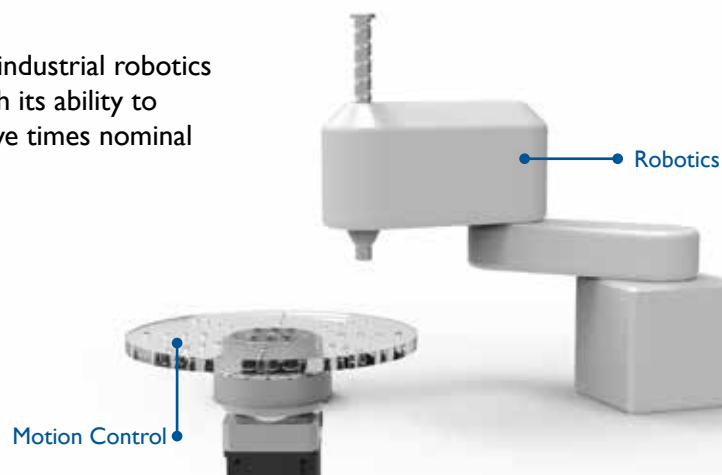

GAM ROBOTIC CYCLOIDAL GEARBOXES

GCL Series Models

GCLC

Component Gearbox



GCLC-F
Solid Flange



GCLC-H
Hollow Flange

GCL

Gearbox with cover & integrated input



GCL-F
Solid Flange

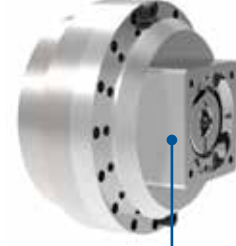

Integrated
Motor Mount

Technical Specifications

GCLC-F/GCL-F		020	040	080	110	160	320**	450**
Ratios		57, 81, 105, 121, 141, 161	57, 81, 105, 121, 153	57, 81, 101, 121, 153	81, 111, 161, 175.28	81, 101, 129, 145, 171	81, 101, 118.5, 129, 141, 153, 171, 185, 201	81, 101, 129, 153, 171, 192.4, 201, 210.23, 257.84
Outer Diameter	mm	145	190	222	244	280	325	370
Nominal Output Torque*	Nm	167	412	784	1078	1568	3136	4410
Input Capacity*	kW	0.35	0.86	1.64	2.26	3.28	6.57	9.24
Power Density	Nm/kg	33.4	45.8	60.3	63.4	60.3	71.3	66.8
Allowable Bending Moment	Nm	882	1666	2156	2940	3920	7056	8820
Torsional Stiffness	Nm/arcmin	49	108	196	294	392	980	1176
Tilting Rigidity	Nm/arcmin	372	931	1176	1470	2940	4900	7448
Backlash Lost Motion		Backlash: ≤1 arcmin Lost Motion: ≤1 arcmin						

*Rated at 15 rpm output speed **Available in GCLC-F Component only

GCLC-H		050	120	200	320	400	500
Base Ratio**		32.54	36.75	34.86	35.61	35.61	37.34
Outer Diameter	mm	222.5	250	347	440	485	520
Nominal Output Torque*	Nm	490	1176	1961	3136	3920	4900
Input Capacity*	kW	1.03	2.46	4.11	6.57	8.21	10.26
Power Density	Nm/kg	32.7	56.0	35.0	39.2	35.6	31.8
Allowable Bending Moment	Nm	1764	3920	8820	20580	26460	34300
Torsional Stiffness	Nm/arcmin	255	588	980	1960	2613	3430
Tilting Rigidity	Nm/arcmin	1960	4263	9800	12740	19600	24500
Through Hole Diameter	mm	57	71	90	138	138	138
Backlash Lost Motion		Backlash: ≤1 arcmin Lost Motion: ≤1 arcmin					

* Rated at 15 rpm output speed ** Base ratio of gearbox, overall ratio determined by input pinion as specified by customer

GAM ROBOTIC CYCLOIDAL GEARBOXES

TYPE CODES FOR GCL SERIES

Example: GCL - F - 080 - 121C - M0000 - H0000 - C0000

Gearbox Series

GCL = Inline with cover & integrated input (-F only)
 GCLC = Inline component with loose input pinion

Gearbox Style

F = Solid Flange Output
 H = Hollow Flange Output

Gearbox Size

F: 020, 040, 080, 110, 160, 320, 450
 H: 050, 120, 200, 320, 400, 500

Ratio

F: 057 to 192
 H: 033 to 037

Configuration Code

Assigned by GAM

Output Code

Assigned by GAM

Motor Code

Assigned by GAM

Input Option (GCL-F Only)

C = Clamp

The GAM Advantage

Find the your exact solution at GAM!

GAM's product range of gear reducers, couplings, and other specialized mechanical drive solutions is one of the largest in the industry. Even with such a wide offering, we realize that you may not find a standard product that meets your exact requirements.

One of our greatest strengths is our ability to modify standard designs, provide completely customized solutions, and integrated product assemblies to meet your specific application requirements. And, because of our flexible manufacturing, we can cost-effectively produce small batches of customized product in short lead-times.

So if you can't find what you are looking for, just ask!

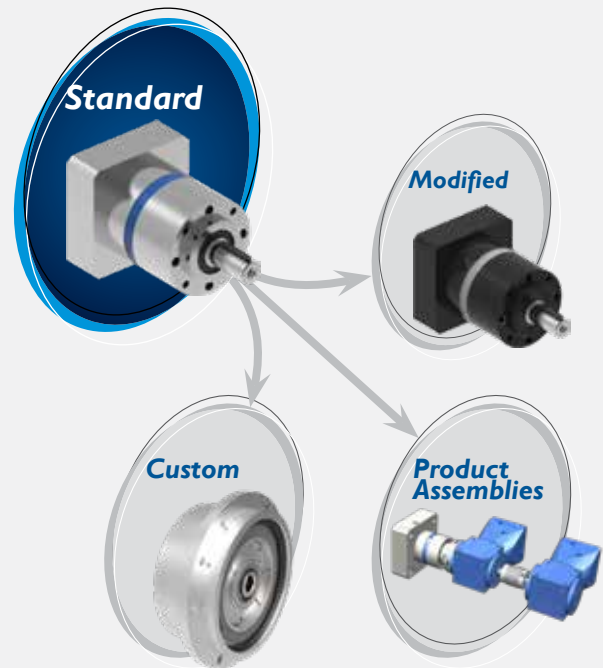

GAM, a U.S. company, is your complete source for Gear Reducers, Servo Couplings, and other precision mechanical drive solutions used in automation technology.

With one of the largest product offerings in the motion control industry as well as the engineering expertise and manufacturing capabilities to develop customized solutions, GAM can help with your application.

U.S. manufacturing, being flexible to meet the needs of customer requests, and great service are what set us apart from the rest.

GAM Can.

GAM Enterprises, Inc.

801 E. Business Center Drive | Mt. Prospect, IL 60056
 Toll-Free: 888.GAM.7117 | Ph: 847.649.2500 | Fax: 847.649.2501
www.gamweb.com | info@gamweb.com



U.S. Company
U.S. Manufacturing

© Copyright 2018 | GAM

gam_br_gr_gcl_1018r1

Courtesy of Steven Engineering, Inc - (800) 258-9200 - sales@steveneng.com - www.stevenengineering.com