

Mechanical Drive Solutions

FOR CARTESIAN ROBOTS

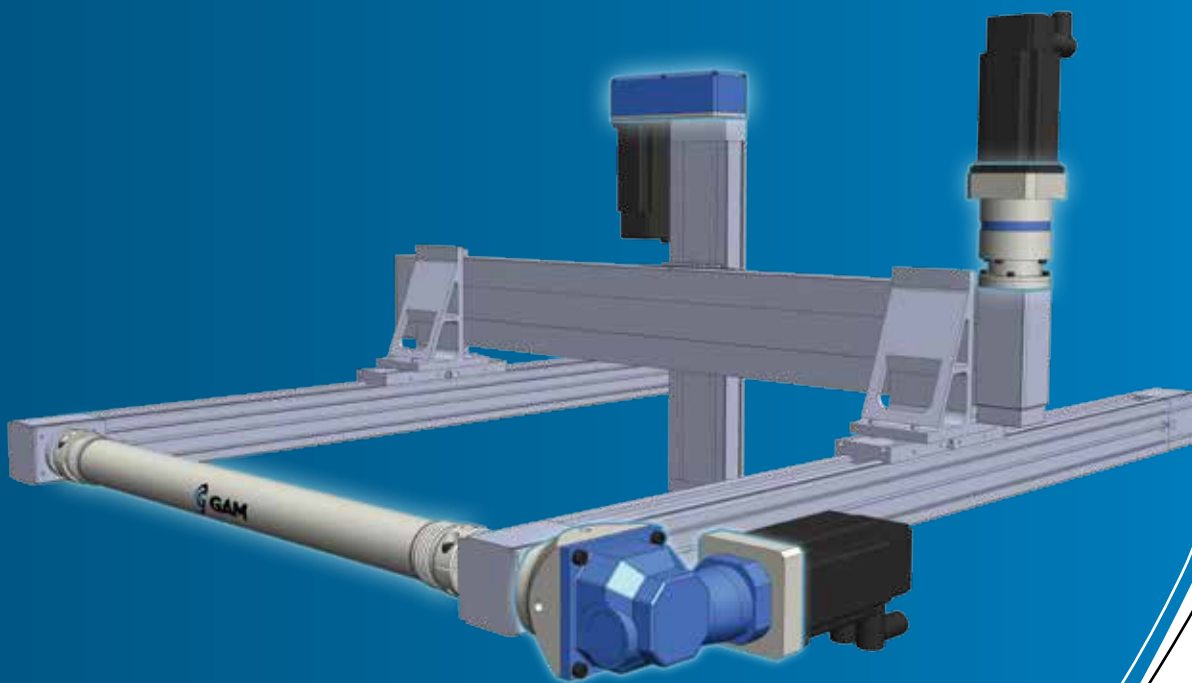

GAM CAN.

Mechanical Drive Solutions for Cartesian Robots

Whether you need assistance with a simple motor mount or mechanical engineering support for a complex assembly, GAM has the product range and design expertise for your next Cartesian robot application. Choose from a variety of inline and right angle gearboxes that connect directly with actuators as well as the necessary mounting adapters, couplings, and rack/pinion components to transform individual products into an integrated robotic solution. Get your Cartesian robot moving with GAM precision mechanical drive solutions.

Gear Reducers

EPL-H Inline Gearbox



- Our most popular in-line planetary with a unique hollow output and zero-backlash clamping ring
- Quick, simple, and low-cost solution used to mount onto any off-the-shelf linear belt or ball screw module
- Ratios up to 1000:1
- Frame sizes from 64 mm to 118 mm

DL-DC Right-Angle Gearbox



- Right angle hypoid gearbox with unique hollow output and zero-backlash clamping ring
- Mount directly to any linear belt or ball screw module for a compact design
- Ratios from 3:1 up to 150:1
- Frame sizes from 55mm to 90mm

Couplings

EDC Distance Coupling



- Elastomer style distance coupling provides vibration and resonance dampening
- Easily connect linear modules
- Split hub design allows for easy assembly
- Higher torque elastomer distance coupling available (EKZ)

WDS Distance Coupling



- Bellows style distance coupling for high torsional rigidity and improved accuracy
- Easily connect linear modules
- Split hub design allows for easy assembly
- A complete range of standard bellows couplings are also available

Mounting Kits

LSK Linear Slide Kit



- Customized assembly to mount any motor or gearbox in-line with any linear belt or ball screw module
- Includes machined adapter plates, bellows or elastomer coupling, and hardware
- Quick delivery

PMK Parallel Mount Kit

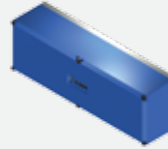

- Customized assembly to mount any motor or gearbox in parallel with any linear ball screw product
- Includes a robust anodized housing, precision machined adapter plate, timing pulleys, belt, and hardware
- Quick delivery

Rack & Pinion

EPL-F Rack & Pinion



- Helical and straight cut rack and pinion solutions
- A variety of quality levels, materials, and treatments offered
- Modules from 1 up to 12
- Customized versions available for special applications

**Everything between the
Motor and Actuator**

Products Designed for Actuators



ANY MOTOR, ANY ACTUATOR

- Regardless of motor or actuator manufacturer, GAM can provide a drive solution
- Years of experience, proven design calculators, and quality systems ensure proper interface between components



COMMON COMPONENTS, COST EFFECTIVE SOLUTIONS

- By using common components, it is possible to provide these solutions quickly and cost effectively
- Special adapters that match actuator housing profiles are available upon request

GAM Advantage

Comprehensive Product Range

- Gear Reducers, Couplings, and Adapter Kits that interface directly with actuators and other mechanical devices
- A complete offering of standard products that can also be integrated together for endless design options
- "For **everything** between the motor and actuator"



- Expertise integrating individual products together into complete system solutions
- GAM designs and manufactures all adapters required for assembly
- Ensures proper configuration and performance specifications are met

Product Integration

Engineering Design Collaboration

- GAM's experienced team of engineers are eager to help solve design challenges and collaborate with your engineers
- Thorough understanding of complex assembly requirements and sizing considerations
- Consultative approach reduces iterations for a streamlined design process



- Pre-engineered components and modular designs enable short leadtimes
- Quick time to market for modified and special configurations
- Flexible manufacturing operations

Efficient Production Systems

Improved Mechanical Solutions

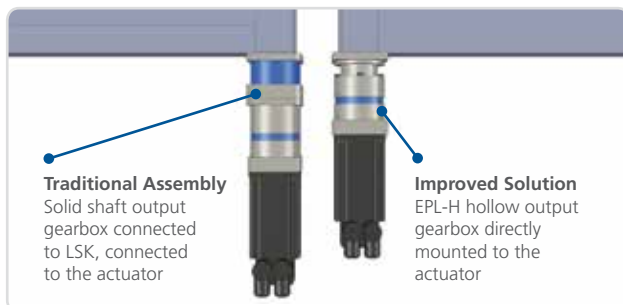

Traditional Assembly
Solid shaft output gearbox connected to LSK, connected to the actuator

Improved Solution
EPL-H hollow output gearbox directly mounted to the actuator

ELIMINATE COMPONENTS

- Fewer components and direct mounting result in increased rigidity
- Installation is easier and simplified



SAVE VALUABLE SPACE

- Bring power transmission elements closer to the machine
- Reduce machine footprints

Application Examples

1

Actuator System

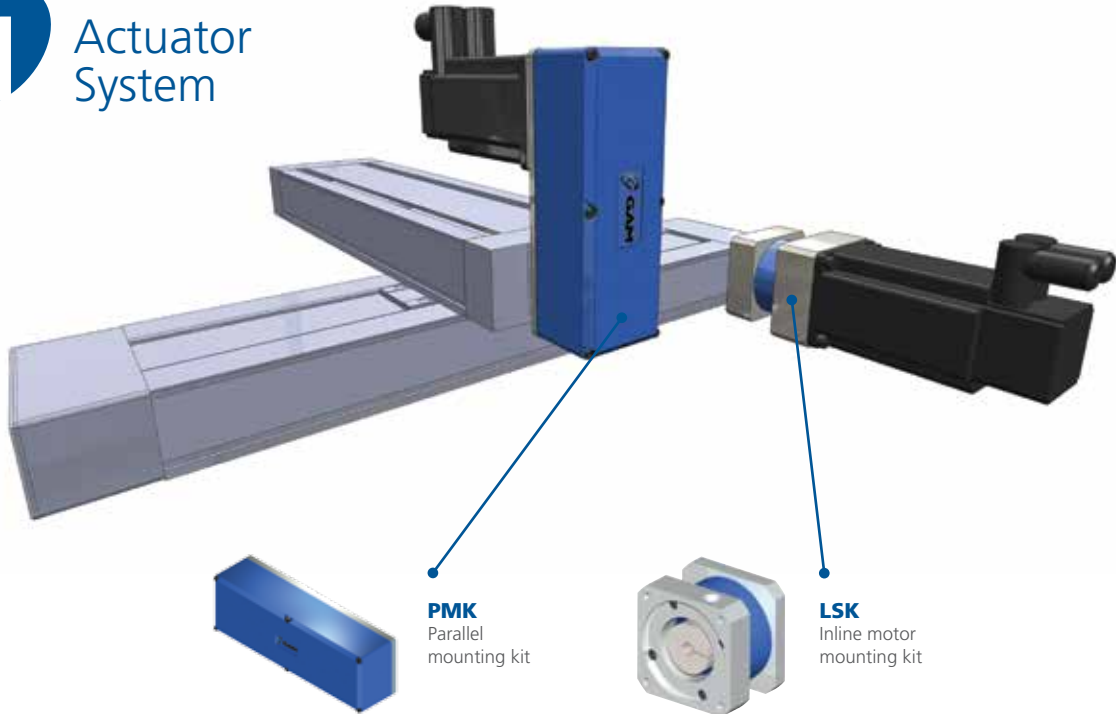

2

Actuator System

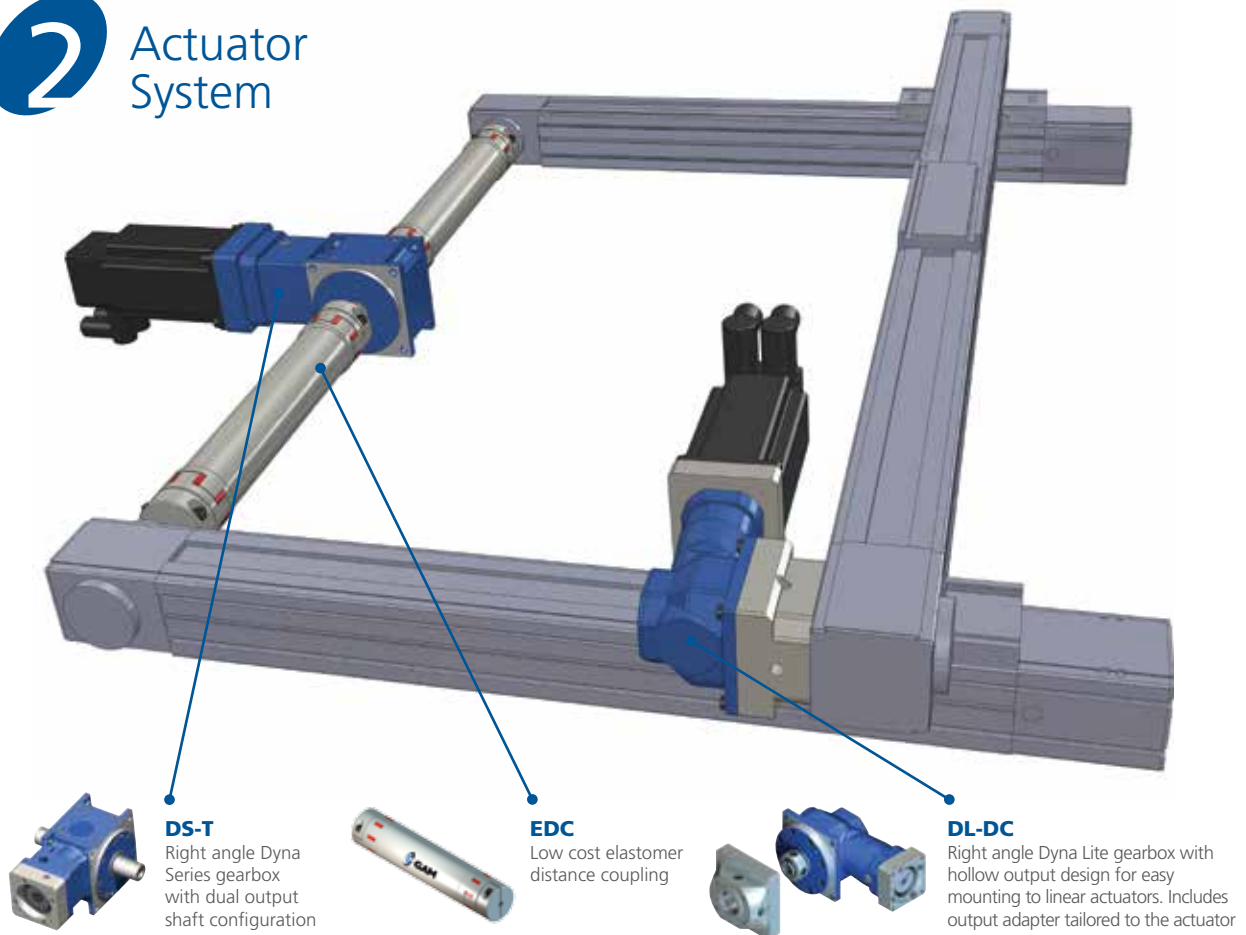

Application Examples

3 Actuator System

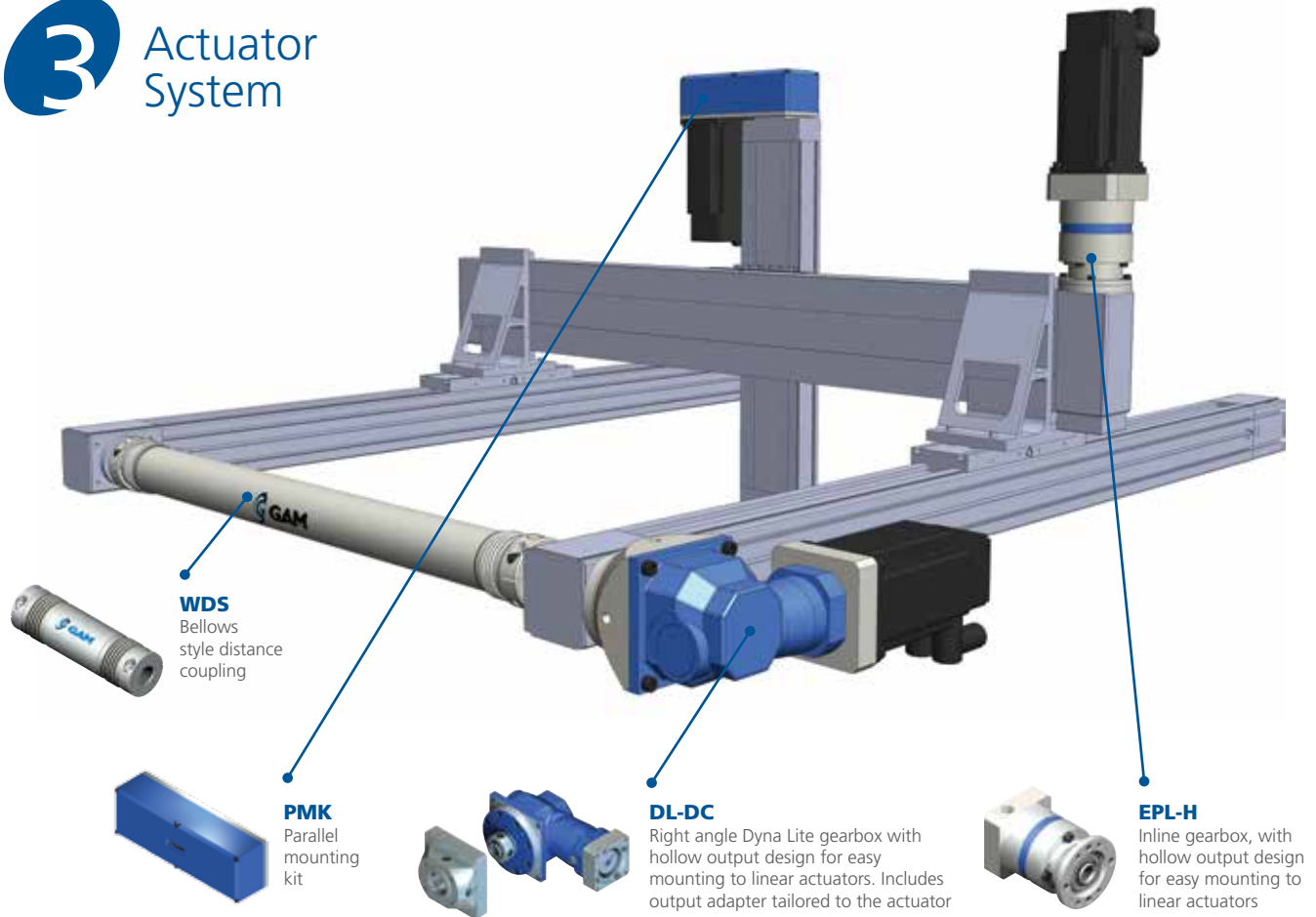

4 Lift System

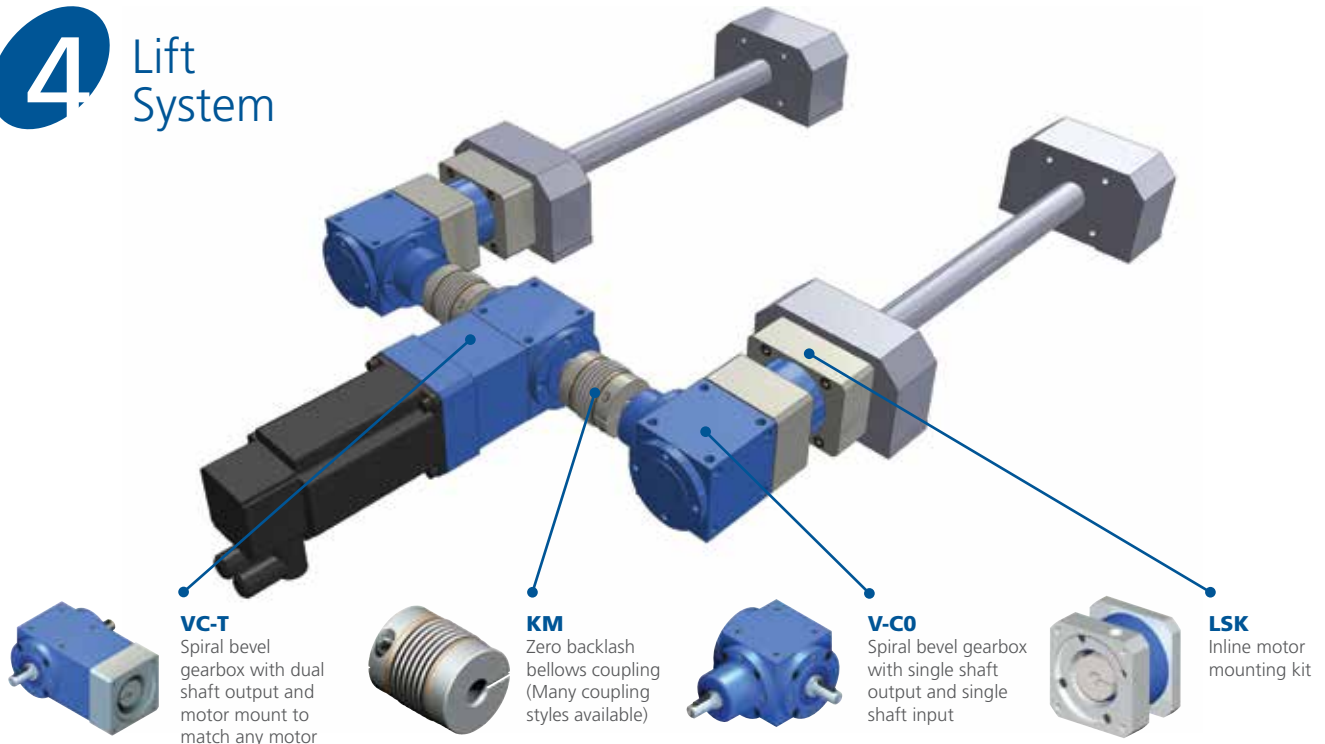

Application Examples

5 Lift System

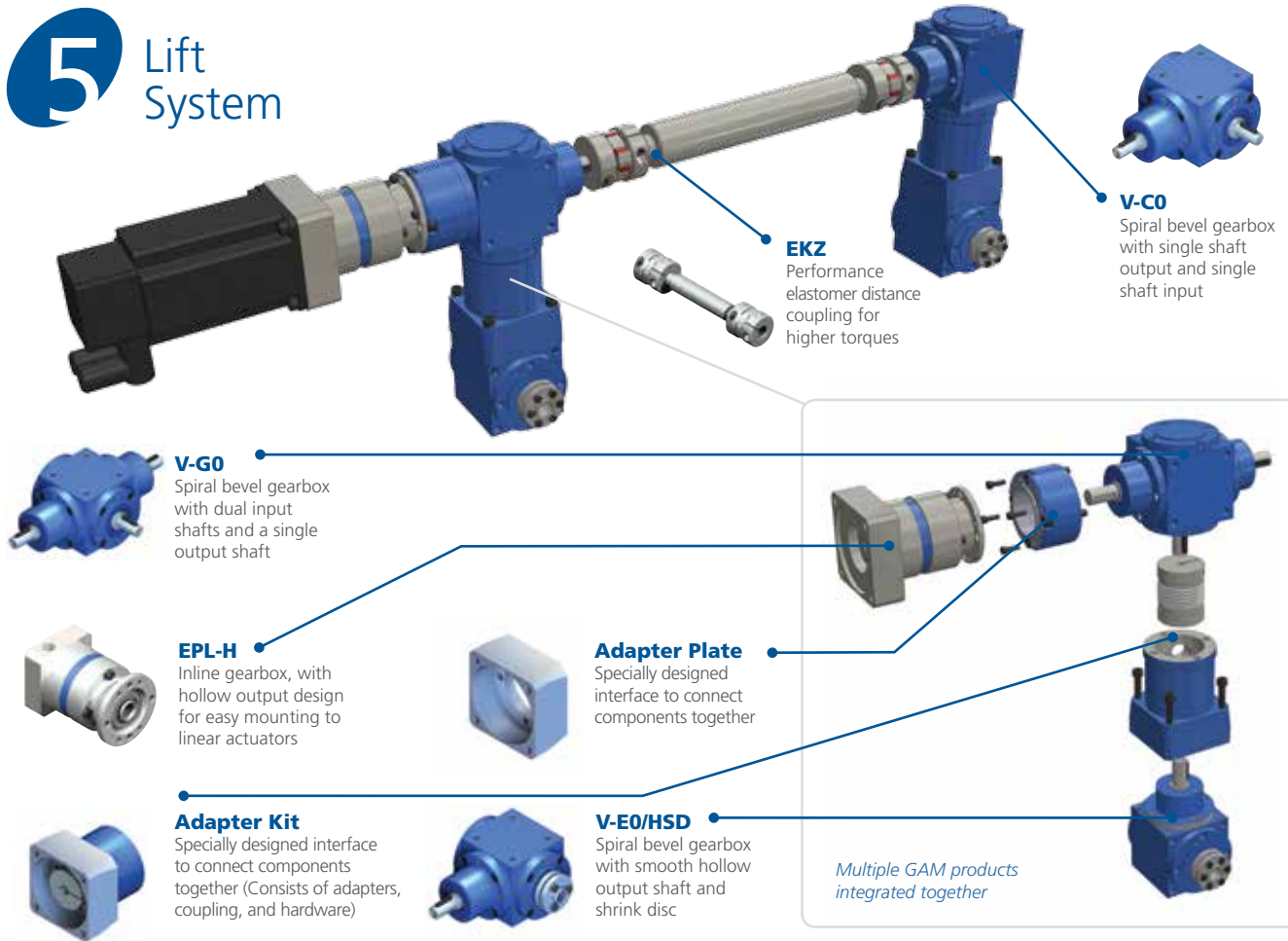

6 Lift System (Exploded View)

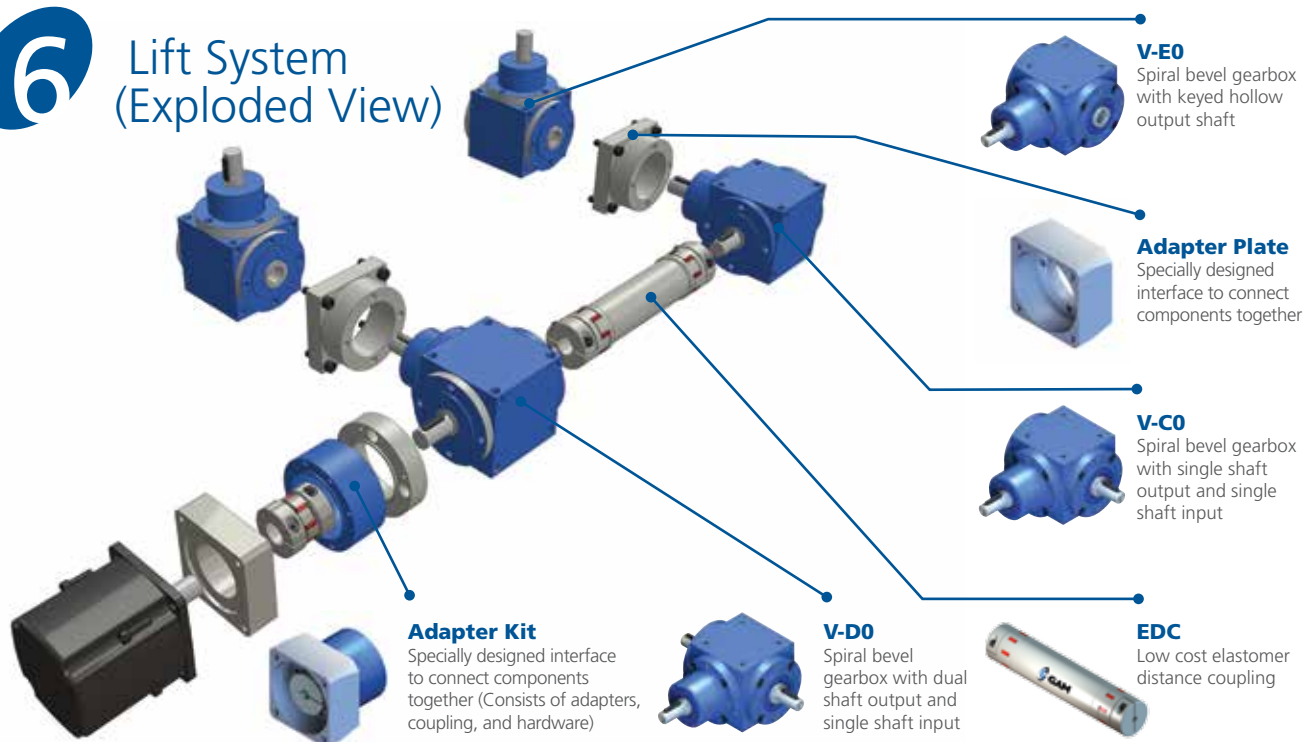

Application Examples

GAM excels at taking **standard** products and providing **unique solutions** to meet special application requirements.



DL-DC Gearbox with Extended Shaft

This hollow output gearbox was designed with a solid shaft extended through the back side of the housing. This feature allowed two actuators to be geared and connected while eliminating the need for an additional mounting kit.



VC Spiral Bevel Gearbox for Actuator

GAM designed a unique hollow clamping element and adapter to connect a VC to an actuator. A spiral bevel gearbox was used because a 1:1 ratio was required for this application.

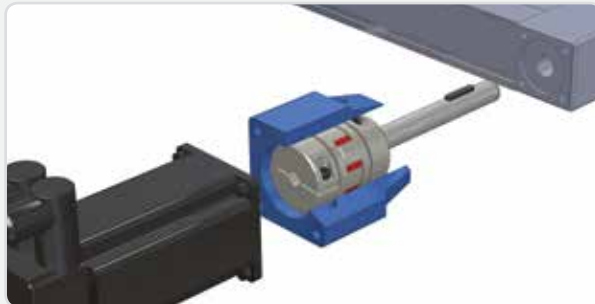

LSK with Stub Shaft

GAM can provide a stub shaft to be used in conjunction with the LSK for mounting to actuators with hollow drive units.

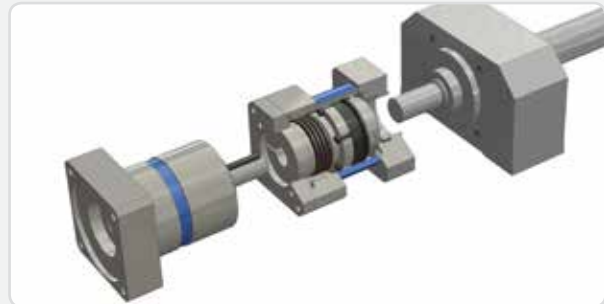

LSK with Safety Coupling

GAM has a wide selection of safety couplings that can be used in LSK assemblies to protect systems during crash or overload situations.



Multishaft V-Series Gearbox with Adapters

For this unique application, GAM provided a standard spiral bevel gearbox and designed two motor adapters along with an output plate that matched the dimensions of the primary motor.



Stainless Steel Assembly

For a wash down application, GAM provided a stainless steel V-Series spiral bevel gearbox, a KG-VA stainless steel coupling, and a stainless steel adapter.



GAM is your complete source for Gear Reducers, Servo Couplings, and other precision mechanical drive solutions used in automation technology.

With one of the largest product offerings in the motion control industry as well as the engineering expertise and manufacturing capabilities to develop customized solutions, GAM can help with your application.

Being flexible to meet the needs of customer requests and great service are what set us apart from the rest.

GAM Can.

801 E. Business Center Drive

Mt. Prospect, IL 60056

Toll-Free: 888.GAM.7117

Ph: 847.649.2500

Fax: 847.649.2501

General Inquiries: info@gamweb.com



Visit gamweb.com



Email a **GAM**
Applications Engineer



GAM Website

- Clean layout for easy navigation
- Continually updated with pertinent news and information
- Online catalog with over 16,000 products
- Search products on performance specifications or by part number

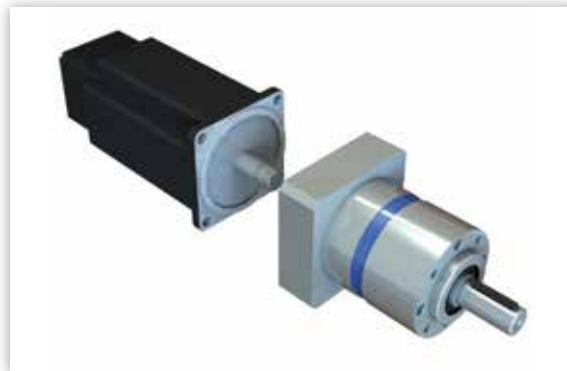

NEW Sizing Tool

- Quickly size the right gear reducer, coupling, or mounting kit compatible with your motor
- Over 9,000 popular servomotors available
- Easily narrow down the products that match
- Compare matching products side-by-side



Download CAD models

- All products configured to your specifications
- Quickly download CAD models in popular 2D / 3D formats
- Motor selection tool simplifies adapter plate generation
- Actuator selection tool generates adapter plates for mounting kits