

GAM SPH Series **HELICAL PLANETARY GEARBOX**



GAM CAN.

GAM SPH HELICAL PLANETARY GEARBOXES

The **SPH series** features helical gearing which brings a whole new level of power and precision to GAM's already extensive portfolio of gear reducer technology. With special attention paid to every aspect during development, the SPH gracefully combines design and engineering, to deliver our best inline planetary gear reducer yet.

For dynamic and demanding servo applications where performance is critical, the SPH is highly powerful and efficient, yet smooth and quiet.

- 1. Helical Gears** Precision cut and meticulously inspected to quietly deliver higher torques and accuracies
- 2. Adapter Flange** Custom machined to match any motor for easy installation
- 3. Input Clamping Element** Low inertia and balanced for high speeds with a single tangential screw ensures a secure motor connection
- 4. Bearings** Optimized taper roller bearings to accommodate high radial and axial loads
- 5. Housing** Sleek and contoured steel housing with black oxide treatment for maximum durability
- 6. Ring Gear** Machined directly into the single piece housing for maximum stiffness
- 7. Output Shaft** Offered smooth or keyed and can be easily shortened if required. Flange output style now available.

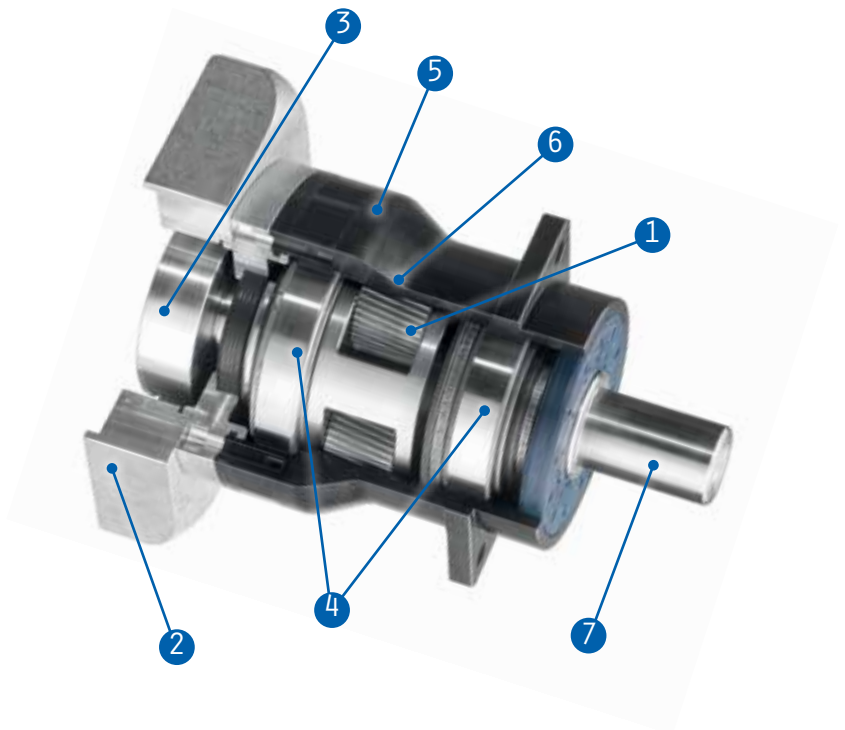

Available configurations for simple and compact machine integration



SPH-W

Shaft output design for mounting to pulleys and rack and pinion systems. Available with a smooth or keyed output shaft.



SPH-K

Features a bellows coupling on the output for maximum stiffness and the best results in highly dynamic applications. An output housing comes standard with custom housings available.



SPH-C

Same benefits as the SPH-K models without the housing on the output. Plug the gearbox directly into your machine and achieve a more compact design.



SPH-F

Flange output design for direct mounting of pinions and other machine elements. The latest addition to the SPH product line.



SPH-SP

Splined-Shaft output with GAM Helical Pinion. Use with GAM Helical Rack for a complete linear system



GAM SPH HELICAL PLANETARY GEARBOXES

Limit Lost Motion with the SPH Flange

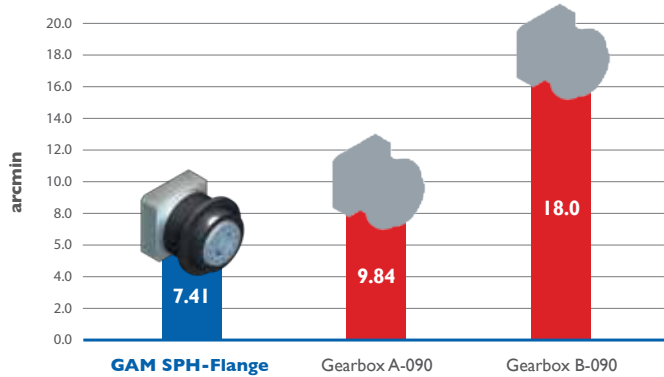

Lost Motion (LM) in arcmin, was calculated using the following formula: $LM = (1/Ct) * Ta + j$

Where: Ct= Torsional Rigidity (Nm/arcmin)
 Ta= Application Torque (Nm)
 j= Output Backlash - Standard (arcmin)

Backlash and Torsional Rigidity are both important values to consider when selecting a high precision gearbox as they both affect lost motion.

In this example, the SPH Flange (size 75, 5:1 ratio, standard backlash <3 arcmin, rigidity 34 Nm/arcmin) was compared to two equivalent standard backlash flange gearboxes available on the market.

Using an application torque value of 150Nm, gearbox A-090 and gearbox B-090 exhibit 33% and 143% more lost motion respectively than the SPH Flange.

SPH-F

Low Backlash
 <3 arc-min standard
 <1 arc-min reduced

The SPH Series Drives Machine Tool Applications

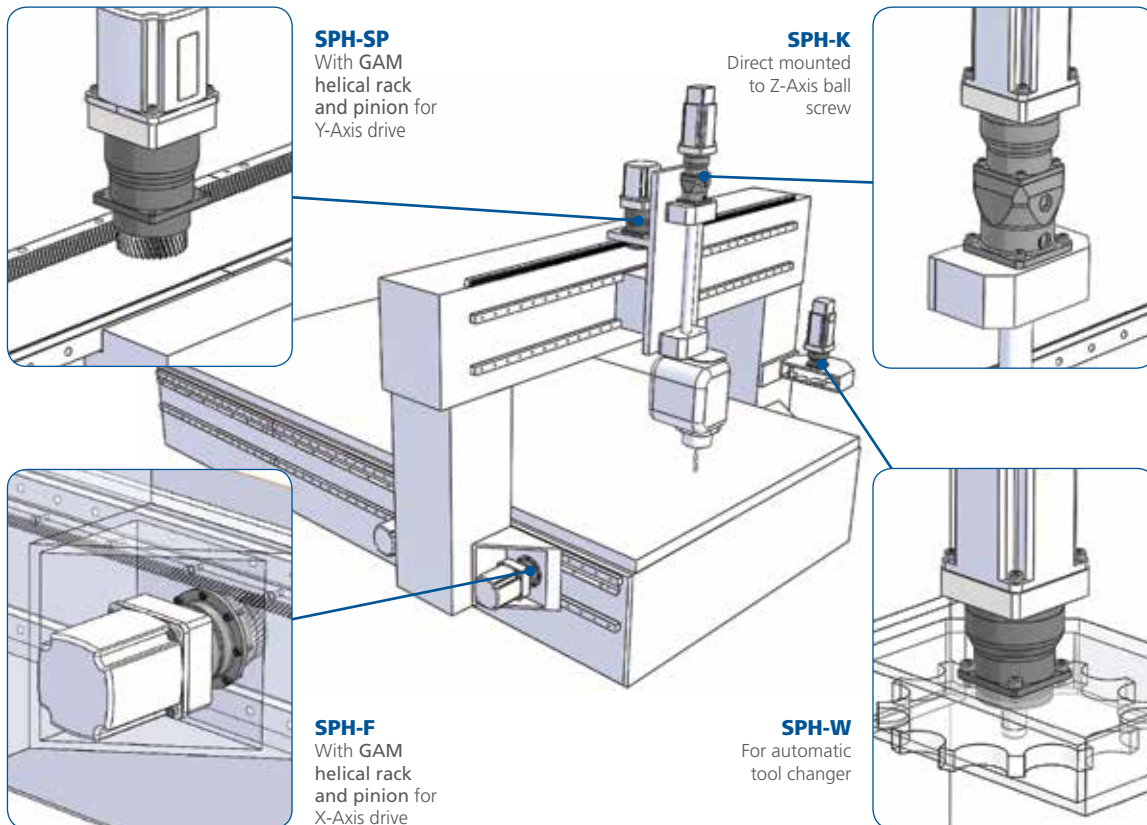

Other Industries Include:

Automation & Assembly • Material Handling • Medical • Packaging
 • Printing & Converting • Robotics • Semiconductor

GAM SPH HELICAL PLANETARY GEARBOXES

The SPH is GAM's highest performing inline gear reducer

Designed for **dynamic**
& **cyclic** applications

Capable of **high speed** and
continuous applications

SPH -Refinement and Power

The helical gear profile is cut at an angle that allows for gradual tooth engagement allowing for smooth, accurate, and quiet transmission. This involute design also allows for increased tooth contact which results in greater torque capacity compared to spur gears.

It all starts with the gears

The SPH's helical gears are produced to an extremely high level of quality and precision. With state of the art testing and measuring instruments and qualified personnel, we assure that the SPH will meet and exceed your requirements. With the SPH, every detail counts.

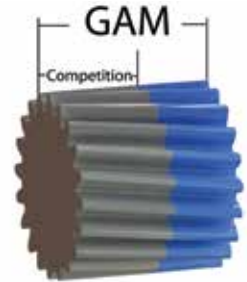

The GAM Advantage

Find the your exact solution at GAM!

GAM's product range of gear reducers, couplings, and other specialized mechanical drive solutions is one of the largest in the industry. Even with such a wide offering, we realize that you may not find a standard product that meets your exact requirements.

One of our greatest strengths is our ability to modify standard designs, provide completely customized solutions, and integrated product assemblies to meet your specific application requirements. And, because of our flexible manufacturing, we can cost-effectively produce small batches of customized product in short lead-times.

So if you can't find what you are looking for, just ask!

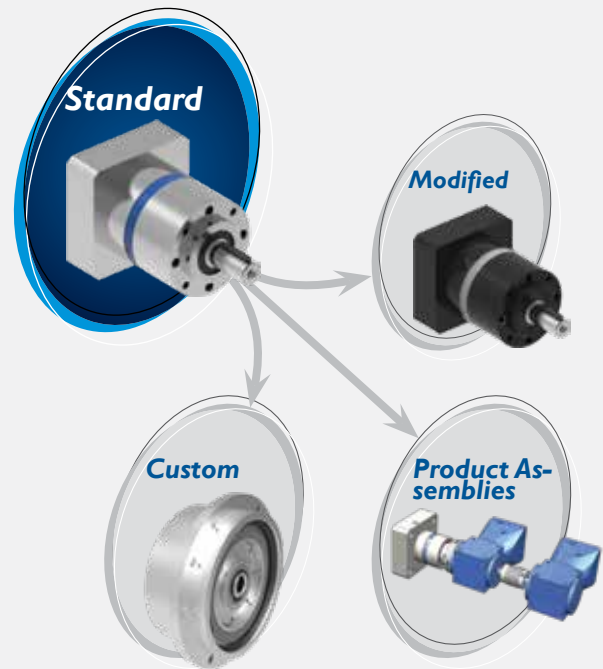

GAM, a U.S. company, is your complete source for Robotic and Servo Gear Reducers, Rack & Pinion Systems, Servo Couplings, and other precision mechanical drive solutions used in automation technology.

With one of the largest product offerings in the motion control industry as well as the engineering expertise and manufacturing capabilities to develop customized solutions, GAM can help with your application.

U.S. manufacturing, being flexible to meet the needs of customer requests, and great service are what set us apart from the rest.

GAM Can.

GAM Enterprises, Inc.

801 E. Business Center Drive | Mt. Prospect, IL 60056
Toll-Free: 888.GAM.7117 | Ph: 847.649.2500 | Fax: 847.649.2501
www.gamweb.com | info@gamweb.com



U.S. Company
U.S. Manufacturing

© Copyright 2019 | GAM

gam_br_gr_sph_1019

Courtesy of Steven Engineering, Inc - (800) 258-9200 - sales@steveneng.com - www.stevenengineering.com