

AS series



STANDARDFIT Worm gearmotors Imperial Units



Contents

1	Rossi for You	4
2	Features, benefits and range	8
3	Product Overview	18
4	Accessories and non-standard designs	46
5	Installation and maintenance	52
6	Technical formulae	56

1

Rossi for You



Innovation

Rossi offers a wide range of **solutions for an evolving industry**, flexible and innovative gearboxes and garmotors for customer tailored solutions to maximize performance and minimize the total cost of ownership.



High quality, 3 years warranty

Our drive is to innovate and boost operations by manufacturing performing, precise, reliable and high-quality products all over the world. We are always one step forward in offering and developing solutions that can satisfy an unlimited number of application needs, even in the most demanding conditions.



Reliability

We are a reliable company with the right flexibility and know-how to respond to worldwide market requests, in all application fields, without leaving aside our commitment for the environment and value on human safety, to protect everyone's future.



Tools and processes

We continue to invest in new tools and processes, so our highly skilled specialist team in different fields are supporting you to find the best solution suitable for your demands, always by your side on every step of the project.



After-sale service

Highly trained mechanics and support teams can ensure a fast and efficient after-sale service providing support worldwide.



Digital support

Alongside our 24/7 **Rossi for You** support portal you have a suite of digital support tools enabling real time access to your order tracking, invoices, spare part tables download and contact to our service.



Experience

Shaped by more than 60 years of history Rossi meets your unique needs whether you need a standard design or a customized solution.



Global presence local service



Local support

Sales, customer service,
technical support, spare parts



15 branches*



Worldwide distribution network*

A widespread sales network of subsidiaries and dealers in nearly all industrialized countries. By your side from the design to after-sale phase, Rossi is a flexible and dependable partner throughout the world.

Rossi for You, our customer web portal, provides a 24/7 global coordination of the ordering, supply and service processes.

*All contacts available on www.rossi.com



United States

Suwanee, GA



Brazil

Cordeiropolis, SP



 Sede
Headquarters

 Filiali
Branches

 Stabilimenti di produzione/Centri di montaggio
Production facilities/Assembly plants

United Kingdom

Coventry



Netherlands

Panningen



Germany

Dreieich



Poland

Wroclaw



Turkey

Izmir



China

Shanghai



Souzhou



Taiwan

Kaohsiung City



Spain

Barcelona



France

Saint Priest



Italy

Modena



Ganaceto



Lecce



India

Coimbatore



Australia

Perth



South Africa

La Mercy



Malaysia

Kuala Lumpur



Features, benefits and range

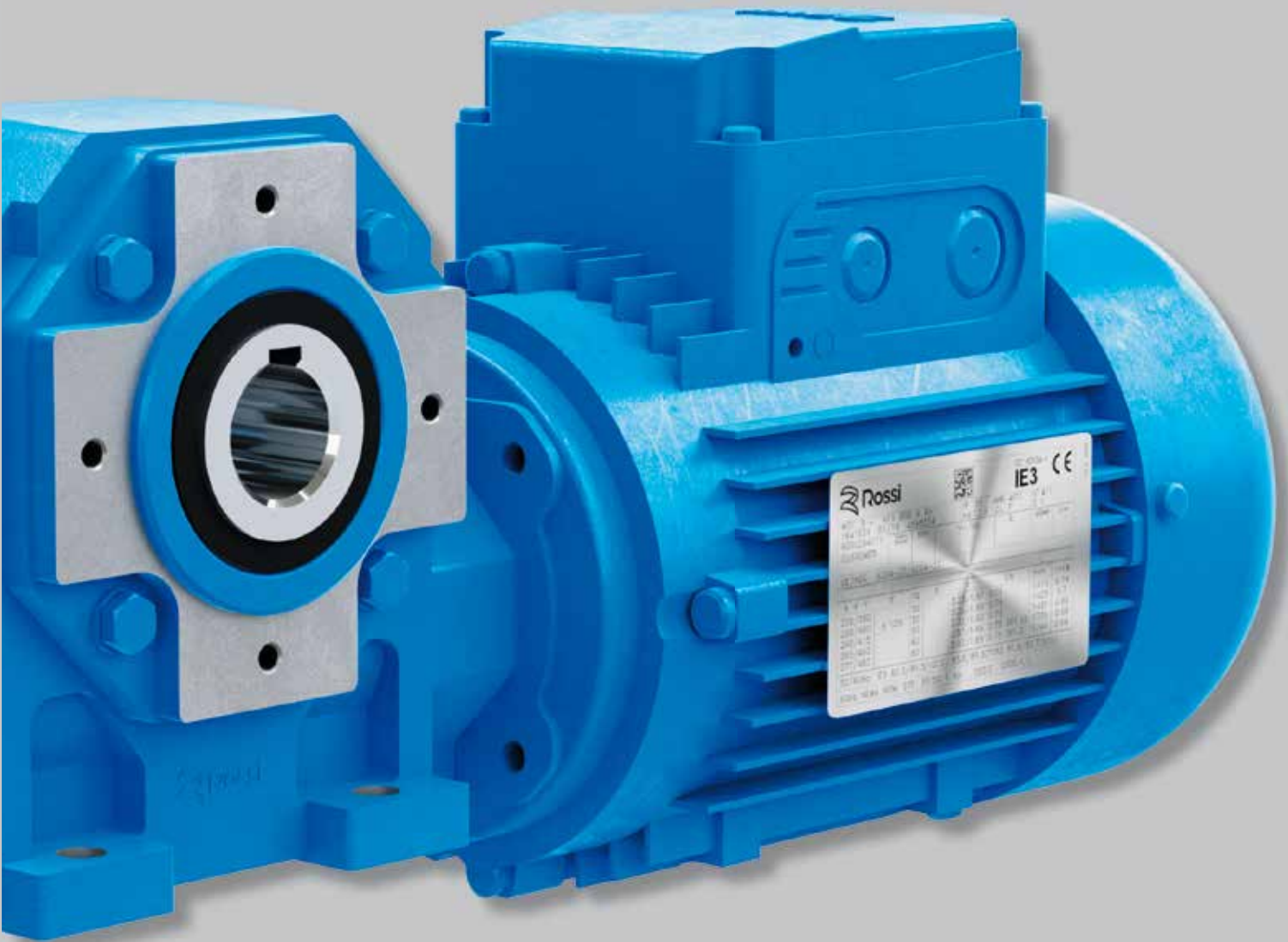



Maximum performance

We drive the heaviest applications worldwide

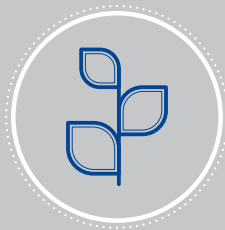

Sustainability

We care about environment



Modular system

For cost-effective and high quality solutions



Innovation

We are constantly thinking forward, solutions for an evolving industry



Digitalization

Rossi for You is always at your disposal for any info



Know-how

We support you through interdisciplinary know-how

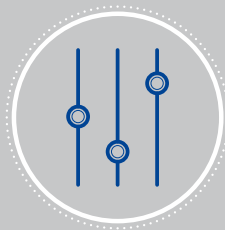

Customization

Cost-effective solutions starting from standard products

2 - Features, benefits and range

Interchangeability (hollow low speed shaft diameters)

Universal mounting with lower feet, integral with housing, and **B14 flange** on 2 faces.

Basic design; **compactness** and **economy**

Motors with mating dimensions standardized to **IEC** and electrical design according to **NEMA MG1-12**.

High, reliable and tested performances (Ni bronze); optimization of worm gear pair performances (**ZI** involute profile and adequately conjugate wormwheel profile)

Rigid and precise cast iron single-piece housing with **motor mounting integral flange**

Generous internal space between train of gears and housing allowing:

- high oil capacity;
- lower oil contamination;
- greater duration of worm-wheel and worm bearings;
- lower running temperature.

Improved and up-graded modular construction both for components and assembled product which ensures manufacturing and product management flexibility

High manufacturing quality standard

Reduced maintenance

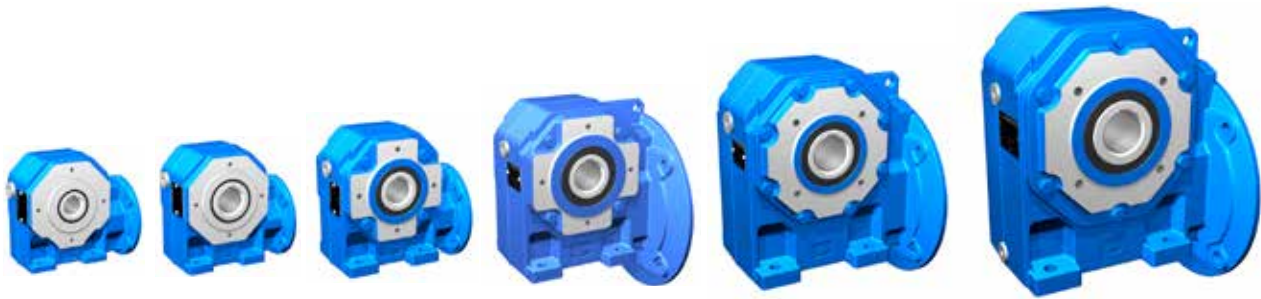

UTC 1346

118	225	325	430	535	742	1)
0.75	1	1.125	1.25	1.375	1.625	U
280	500	950	1 700	3 000	5 400	T_{N2}
450	600	900	1 250	1 450	1 700	F_{r2 max}

1) D Ø low speed shaft end
 T_{N2} max nominal torque ($n_1=1\ 750$ rpm) [lbf in]
 F_{r2} max radial load (OHL) [lbf]

a - Gear reducer

Structural features

Main specifications are:

- **universal mounting** having lower **feet integral with housing** and **B14 flange** (integral with housing for sizes 118, 225) on the 2 output faces of hollow low speed shaft. **B5 flange** with spigot «recess» which can be mounted onto B14 flanges (see ch. 4);
- **flange** for **motor mounting integral** with the housing;
- nodular cast iron hollow low speed shaft integral with worm-wheel, with keyway;
- standard (left or right extension) or double extension low speed shaft (see ch. 4).
- **motor directly keyed** into the worm;
- bearings on worm: face-to-face taper roller bearings;
- bearings on worm-wheel: ball bearings with low friction rubber seals;
- 200 UNI ISO 185 **cast iron single-piece housing** with transverse stiffening ribs, and high oil capacity;
- oil bath lubrication with **synthetic oil** (ch. 3.2) for «**long-life**» lubrication: gear reducers with one plug (two plugs for size 742) supplied **filled with oil**; sealed;
- paint: external coating in epoxy powder paint appropriate for resistance to normal industrial environments and suitable for the application of further coats of synthetic paint; colour blue RAL 5010 DIN 1843; internal protection in epoxy powder paint appropriate for resistance to synthetic oils.

2 - Features, benefits and range

Train of gears:

- worm gear pair;
- **6 sizes** with final reduction center distance to R 10 series;
- nominal transmission ratios to R 10 series (6 ... 75);
- casehardened/hardened cylindrical worm made of 16MnCr5 EN 10084-98 steel with ground and **superfinished involute profile (ZI)**;
- worm-wheel with profile especially conjugate to the worm through hob optimization, with hub in nodular cast iron and **Ni bronze CuSn12Ni2-B** (EN1982-98) gear rim with high pureness and controlled phosphor contents;
- train of gear load capacity calculated for breakage and wear; thermal capacity verified.

Specific standards:

- nominal transmission ratios and principal dimensions according to UNI 2016 standard numbers (DIN 323-74, NF X 01.001, BS 2045-65, ISO 3-73);
- basic rack to BS 721-83; involute profile (ZI) to UNI 4760/4-77 (DIN 3975-76), ISO/R 1122/2-69);
- fixing flanges B14 and B5 (the latter with spigot «recess») taken from UNEL 13501-69 (DIN 42948-65, IEC 72.2);
- parallel keys to UNI 6604-69 (DIN 6885 Bl. 1-68, NF E 27.656 and 22.175, BS 4235.1-72, ISO/R 773-69) except for specific cases of motor-to-gear reducer coupling where key height is reduced;
- mounting positions taken from UNEL 05513-67 (DIN 42950-64, IEC 34;7);
- worm gear pair load capacity and efficiency to **BS 721-83** inte-grated with ISO/CD 14521.

Sound levels

The standard levels of sound power emission L_{WA} relevant to the gearmotors of this catalogu, running at nominal load and speed, fulfil the limits settled by VDI 2159 for gear reducers and EN 60034 for motors.

2 - Features, benefits and range

Short time duty (S2) and intermittent periodic duty (S3); duty cycles S4 ... S10

In case of a duty-requirement type S2 ... S10 the motor power can be increased as per the following table; starting torque keeps unchanged.

Short time duty (S2). — Running at constant load for a given period of time less than that necessary to reach normal running temperature, followed by a rest period long enough for motor's return to ambient temperature.

Intermittent periodic duty (S3). — Succession of identical work cycles consisting of a period of running at constant load and a rest period. Current peaks on starting are not to be of an order that will influence motor heat to any significant extent.

$$\text{Cyclic duration factor} = \frac{N}{N+R} \cdot 100\%$$

where: N being running time at constant load,
 R the rest period and $N + R \leq 10$ min (if longer consult us).

Duty			Motor size ¹⁾		
			63 ... 90	100 ... 132	160 ... 280
S2	duration of running	90 min	1	1	1.06
		60 min	1	1.06	1.12
		30 min	1.12	1.18	1.25
		10 min	1.25	1.25	1.32
S3	cyclic duration factor	60%	1.12		
		40%	1.18		
		25%	1.25		
		15%	1.32		
S4 ... S10			consult us		

1) For motor sizes 90LC 4, 112MC 4, 132MC 4, consult us.

Frequency 60 Hz

Normal motors up to size 132 wound for 50 Hz can be fed at 60 Hz; in this case speed increases by 20%. If input-voltage corresponds to winding voltage, power remains unchanged, providing that higher temperature rise values are acceptable, and that the power requirement is not unduly demanding, whilst starting and maximum torques decrease by 17%. If input-voltage is 20% higher than winding voltage, power increases by 20% whilst starting and maximum torques keep unchanged.

For **brake** motors see **specific literature**.

From size 160 upwards motors — both standard and brake ones — should be would for 60 Hz exploiting the 20% power increase as a matter of course.

Power available with high ambient temperature or high altitude

When motor has to run at an ambient temperature higher than 104 °F or at altitude above sea level higher than 3 300 ft, it has to be derated according to the following tables:

Ambient temperature [°F]	86	104	113	122	131	140
P/P_N [%]	106	100	96.5	93	90	86.5

Altitude a.s.l. [ft]	3 300	4 900	6 600	8 200	9 800	11 500	13 100
P/P_N [%]	100	98	92	88	84	80	76

Specific standards:

- nominal powers and dimensions to CENELEC HD 231 (IEC 72-1, DIN 42677, NF C51-120, BS 5000-10 and BS 4999-141) for mounting positions IM B5, IM B14 and derivatives;
- nominal performances and running specifications to CENELEC EN 60034-1 (IEC 34-1, CEI EN 60034-1, DIN VDE 0530-1, NF C51-111, BS EN 60034-1);
- protection to CENELEC EN 60034-5 (IEC 34-5, CEI 2-16, DIN EN 60034-5, NF C51-115, BS 4999-105);
- mounting positions to CENELEC EN 60034-7 (IEC 34-7, CEI EN 60034-7, DIN IEC 34-7, NF C51-117, BS EN 60034-7);
- balancing and vibration velocity (vibration under standard rating N) to CENELEC HD 53.14 S1 (IEC 34-14, ISO 2373 CEI 2-23, BS 4999-142); motors are balanced with half key inserted into shaft extension;
- cooling to CENELEC EN 60034-6 (CEI 2-7, IEC 34-6): standard type IC 411; type IC 416 for non-standard design with axial independent cooling fan.

Asynchronous three-phase motors, brake motors



HB

Asynchronous three-phase motor



HBZ

Asynchronous three-phase **brake motor** with **d.c. brake**



HBF

Asynchronous three-phase **brake motor** with **a.c. brake**



HBV

Asynchronous three-phase **brake motor** with **d.c. safety brake**

2 - Features, benefits and range

Advanced design motors sharing the **same stator windings**, the same **rotors**, the same **housings**, the same **flanges**, the same performance, and the majority of technical solutions with its twin brake motor series (**HBZ, HBF, and HBV**).

The generous electromagnetic sizing allow to achieve **high efficiency values** complying **with different energy saving regulations**:

- Efficiency class **IE3 (ErP)** for HB;
- Efficiency class **IE3 (ErP)** on request for HBZ

The electric design (terminal block, name plate, etc.) has been studied to comply, as standard, also with **NEMA MG1-12** for the maximum application flexibility and facility.

The strength and the precision of mechanical construction, the generous bearings and the wide range of non-standard designs available on catalog make this motor particularly suitable for coupling with gearmotors.

Thanks to its outstanding **low noise, progressivity** and **dynamic** characteristics, it is specifically suitable for **coupling with gearmotor minimizing the dynamic overloads** deriving from **starting and braking phases** (especially in case of motion reversals) and maintaining a **very good braking torque value**.

The excellent **operation progressivity** - when starting and braking - is assured by the brake anchor which is less quick in the impact (compared to a.c. HBF) and by the slight quickness of d.c. brakes.

Offering a comprehensive **range of accessories and non-standard designs** in order to satisfy all possible gearmotor application fields.

The **high reactivity** typical of **a.c. brake** and the **high braking capacity** make this brake motor **particularly suitable for heavy duties** requiring **quick brakings** and a **high number of operations** (e.g.: lifts with high frequency of starting, usually for size > 132, and/or for jog operations).

Vice versa, its very **high dynamic characteristics** (rapidity and frequency of starting) **are not advisable for the use in gearmotor** coupling, especially when these features are not strictly necessary for the application (avoiding useless overloads on the whole transmission).

Comprehensive **range of accessories and non-standard designs** in order to satisfy all application needs of gearmotors (in particular for HBF: IP 56, IP 65, encoder, independent cooling fan, independent cooling fan and encoder, double extension shaft, etc.).

Featuring **maximum economy, very reduced overall dimensions and moderate braking torque**, it is suitable for the coupling with gearmotor and can be applied as brake for **safety or parking stops** (e.g. cutting machines) and for operations at deceleration ramp end **during the running with inverter**.

The standard cast iron fan supplies a flywheel effect increasing the very good progressivity of starting and braking (typical of d.c. brake) being particularly **suitable for «light»¹⁾ traverse movements**.

1) Mechanism group M4 (max 180 starts/h) and on-load running L1 (light) or L2 (moderate) to ISO 4301/1, F.E.M./II 1997.

Symbols, units of measure and conversion table

Symbols and units of measurement

F_{r2}	[lbf]	radial load on low speed shaft end (OHL)	I_N	[A]	rated current of the motor
F_{a2}	[lbf]	axial load on low speed shaft end	I_s	[A]	starting current of the motor
i		transmission ratio	WK_L^2	[lb ft ²]	external moment of inertia (of mass; couplings, driven machine)
i_N		nominal transmission ratio	WK_0^2	[lb ft ²]	moment of inertia (of mass) of the motor
L_{WA}	[dB(A)]	sound power level	z	[start/h]	starting frequency
n_N	[rpm]	nominal speed of the motor	z_0	[start/h]	no-load starting frequency
n_1	[rpm]	input speed of the gearmotor	φa_1	[rad]	revolution of motor shaft during acceleration
n_2	[rpm]	output speed of the gearmotor	φb_1	[rad]	revolution of motor shaft during deceleration
P_N	[hp]	rated motor power	η		gear reducer efficiency
P_1	[hp]	input power of the gearmotor	max		max value
P_2	[hp]	output power of the gearmotor	min		min value
P_{N2}	[hp]	nominal output power of the gearmotor	1		relating to high speed shaft (input)
t_a	[s]	starting time	2		relating to low speed shaft (output)
t_b	[s]	braking time	÷		from ... to
T_N	[lbf in]	nominal torque of the motor	≈		approximately equal to
T_{start}	[lbf in]	starting torque of the motor	≥		greater than or equal to
T_{max}	[lbf in]	max torque of the motor, with direct on-line start	≤		less than or equal to
T_{brake}	[lbf in]	braking torque setting of the motor			
T_{N2}	[lbf in]	nominal output torque of the gearmotor at speed n_2			
T_2	[lbf in]	output torque of the gearmotor at speed n_2			

Conversion table

Length

inch	[in]	=	0.0254	meter	[m]
feet	[ft]	=	0.3048	meter	[m]

Mass

pound	[lb]	=	0.4536	kilogram	[kg]
ounce	[oz]	=	0.0283	kilogram	[kg]

Volume

US liquid gallon	[gal]	=	3.7854	liter	[l]
------------------	-------	---	--------	-------	-----

Temperature

fahrenheit degree	[°F]	=	$1.8 \cdot ^\circ\text{C} + 32$	celsius degree	[°C]
-------------------	------	---	---------------------------------	----------------	------

Force

pound-force	[lbf]	=	4.4482	newton	[N]
pound-force	[lbf]	=	0.4536	kilogram force	[kgf]

Power

horse power	[hp]	=	0.7457	kilowatt	[kW]
-------------	------	---	--------	----------	------

Torque, Work

pound-force inch	[lbf in]	=	0.1130	newton meter, joule	[N m], [J]
pound-force inch	[lbf in]	=	0.0115	kilogram-force meter	[kgf m]
pound-force foot	[lbf ft]	=	1.3560	newton meter, joule	[N m], [J]
pound-force foot	[lbf ft]	=	0.1383	kilogram-force meter	[kgf m]

Moment of inertia

WK^2	[lb ft ²]	=	0.0421	kilogram square-meter	[kg m ²]
--------	-----------------------	---	--------	-----------------------	----------------------

Product overview





Section content

3.1	Designation	20
3.2	Mounting positions and lubrication	22
3.3	Thermal power	23
3.4	Service factor	24
3.5	Selection	25
3.6	Radial loads on low speed shaft end	26
3.7	Selection tables	27
3.8	Dimensions	36
3.9	Structural and operational details	42

3.1 - Designation

Designation code

MR V 742 U O 4 A - 28 x 250 - 23,5 V5 HB3 112M4 230.400-50 B5 TB3

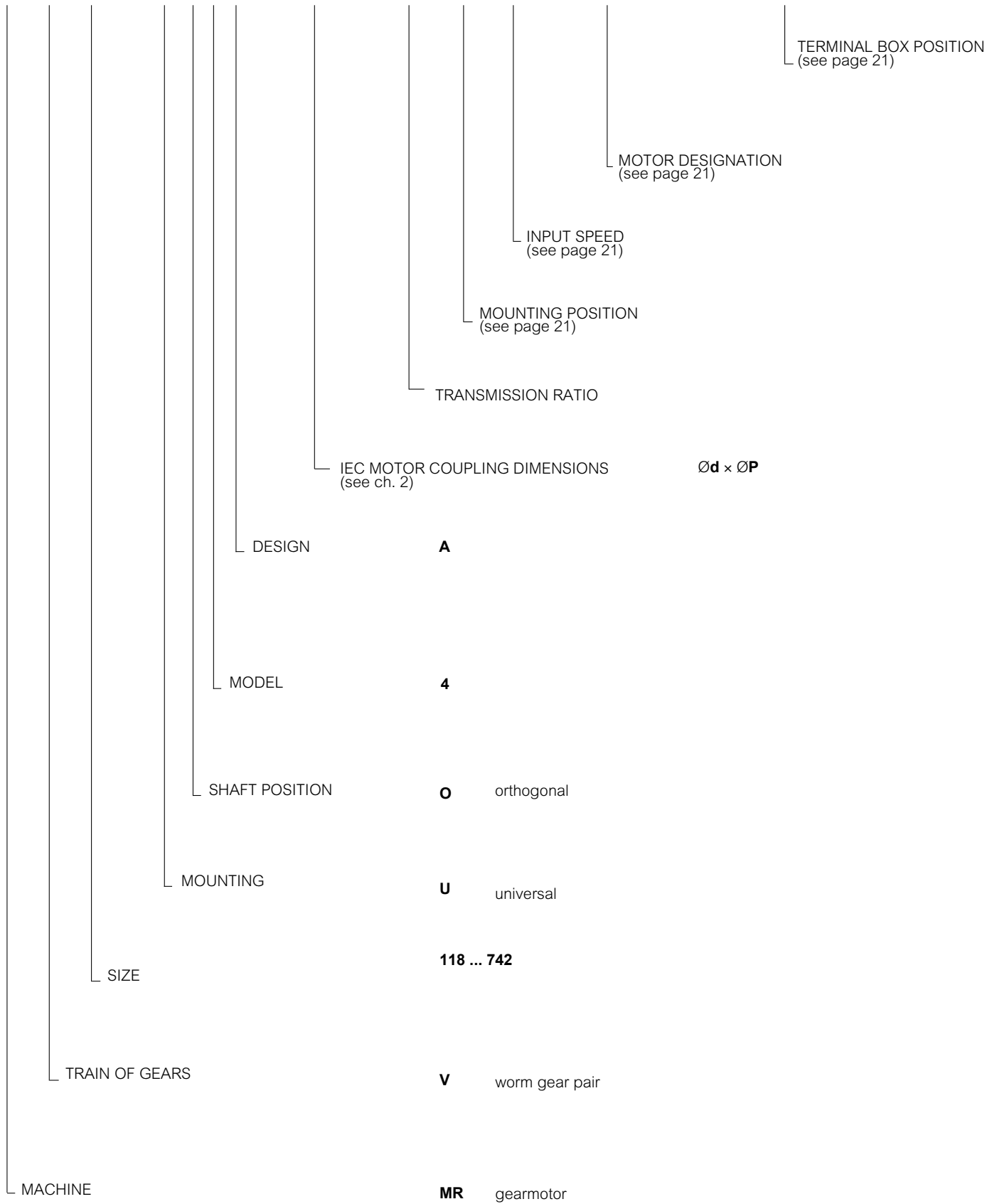

3.1 - Designation

Gear reducer mounting position

Gear reducer and gearmotor mounting positions are described in ch. 3.2 (the mounting position designation refers to foot mounting only, even if gear reducers are for universal mounting; e.g.: B14 flange fastening and derivatives; B5 flange fastening and derivatives, see ch.2).

When having no particular needs, **prefer B3 mounting position** for its technical and economic cost effectiveness (maximum simplification of lubrication system, lower oil splash, lower gear reducer heating, stock availability).

Input speed

Complete the designation stating the input speed n_1 , in the following cases:

– $n_1 > 1800$ rpm;

Example:

MR V 742 UO4A - 28 x 250 - 23,5 B3 $n_1 = 2000$ rpm

Motor

When the gearmotor is supplied **equipped with a standard Rossi motor**, fill in the designation stating the motor designation (ref. cat. TX).

Example:

MR V 742 UO4A - 28 x 250 - 23,5

HB3 112M 4 230.400-50 B5

When **brake motor** is required, insert the letters **HBZ** (ref. cat. TX).

Example:

MR V 742 UO4A - 28 x 250 - 23,5

HBZ 112M 4 230.400-50 B5

When the gearmotor is equipped **without motor**, omit the designation and add «without motor».

Esempio:

MR V 742 UO4A - 28 x 250 - 23,5

without motor

When motor is supplied by the **Buyer**¹⁾, complete the designation by stating the description of «motor supplied by us».

1) The motor, supplied by the Buyer must be to IEC with mating surfaces machined under accuracy rating IEC 60072-1 and is to be sent carriage and expenses paid to our factory for fitting to the gear reducer.

Example:

MR V 742 UO4A - 28 x 250 - 23,5

motore supplied by us

Motor terminal box position

Complete the designation stating the motor terminal box position if differing from the standard one (TB0; see ch. 3.8 and scheme below); the cable input is Buyer's responsibility.

Example:

MR V 742 UO4A - 28 x 250 - 23,5

HB3 112M 4 230.400-50 B5 **TB3**

View from drive end (D)

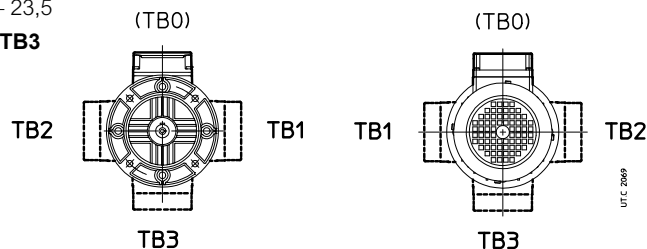

Accessories and non-standard designs

In the event of a gear reducer or gearmotor being required in a design different from those stated above, specify it in detail (ch. 4).

3.2 - Mounting positions and lubrication

Mounting positions (and direction of rotation)

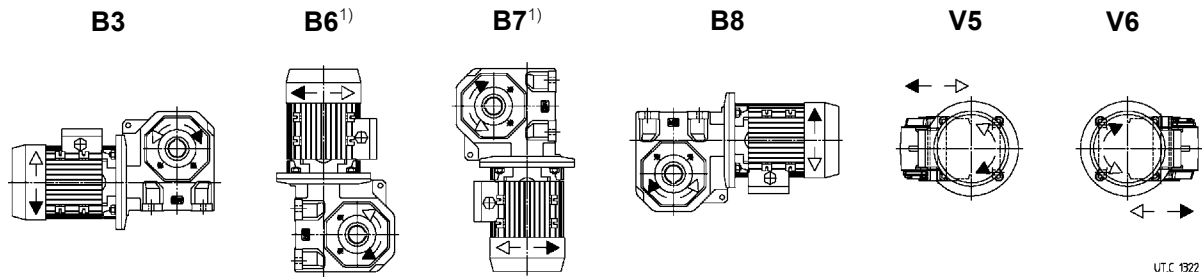

1) For mounting position **B6** or **B7** multiply P_{tN} by **0,9** (ch. 3.3).

Lubrication

Worm gear pairs and bearings are oil-bath lubricated; worm-wheel bearings are lubricated with grease – assuming pollution-free surroundings – «**for life**» (bearings with low-friction rubber seals).

All sizes are envisaged with synthetic oil lubrication (synthetic oils can withstand operating temperature up to **203 - 230 ° F** (95 ÷ 110 °C)).

Gearmotors are supplied **filled with synthetic oil** (AGIP Blasia S 320, KLÜBER Klübersynth GH 6-320, MOBIL Glygoyle 320, SHELL Omala S4 WE 320), providing «**long life**» lubrication, assuming pollution-free surroundings. Ambient temperature 32 - 104 °F (0 ÷ 40 °C) with peaks of -4 °F (-20 °C) and +122 °F (+50 °C).

An overall guide to **oil-change interval**, is given in the table, and assumes pollution-free surroundings. Where heavy overloads are present, halve the value.

Oil temperature [°F]	Oil-change interval [h] - Synthetic oil
≤ 149	18 000
149 ÷ 176	12 500
176 ÷ 203	9 000
203 ÷ 230	6 300

Never mix different makes of synthetic oil; if oil-change involves switching to a type different from that used hitherto, then give the gear reducer a thorough clean-out.

Important: be sure that the gearmotor is installed as per mounting position ordered and stated on the name plate: if the gearmotor is installed in a **different mounting position** verify, according to the values given in the table and/or on the lubrication plate, that the **oil quantity** doesn't **change**; if so, **adjust** it consequently.

Running-in: a period of about 200 ÷ 800 h is advisable, by which time the gear pair will have reached maximum efficiency (ch. 3.9); oil temperature during this period is likely to reach higher levels than would normally be the case.

Seal rings: duration depends on several factors such as dragging speed, temperature, ambient conditions, etc.; as a rough guide it can vary from 3 150 to 12 500 h.

Size	Oil quantities [gal]	
	B3	B6. B7. B8. V5. V6
118	0.04	0.07
225	0.05	0.08
325	0.08	0.12
430	0.16	0.24
535	0.29	0.42
742	0.58	0.77

Plug position

Gearmotors are provided with 1 plug (2 plugs for size 742) positioned as in the figure. No level plug is foreseen.

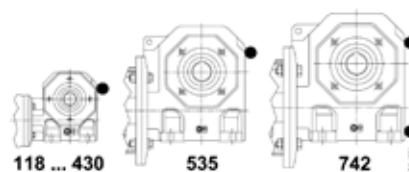

3.3 - Thermal power P_t [hp]

The nominal thermal power P_{tN} is that **power which can be applied at the input side of the gear reducer**, on continuous duty, at a max ambient temperature of 104 °F (40 °C) and air velocity ≥ 4.1 ft/s without exceeding a 203 °F (95 °C) approximately oil temperature.

The following tables give the nominal thermal power values P_{tN} according to **transmission ratio i** and **motor nominal speed n_1** .

Size **118**

n_1 rpm	P_{tN} [hp]										
	i										
	6	8,5	11	14	17	22	28	35	44	-	-
1 750	1.37	1.12	1.03	0.94	0.74	0.67	0.6	0.55	0.49	-	-
1 150	1.09	0.89	0.8	0.74	0.58	0.53	0.47	0.43	0.39	-	-

Size **225**

n_1 rpm	P_{tN} [hp]										
	i										
	-	8,33	12	15,5	19	24	30	38	47	58	-
1 750	-	1.53	1.24	1.14	1.04	0.82	0.75	0.67	0.61	0.54	-
1 150	-	1.22	0.98	0.89	0.82	0.65	0.59	0.53	0.48	0.43	-

Size **325**

n_1 rpm	P_{tN} [hp]										
	i										
	-	8,33	12	15,5	19	24	30	38	47	58	73
1 750	-	2.1	1.72	1.57	1.43	1.13	1.04	0.92	0.83	0.75	0.66
1 150	-	1.68	1.36	1.24	1.13	0.82	0.82	0.73	0.66	0.6	0.53

Size **430**

n_1 rpm	P_{tN} [hp]										
	i										
	-	8,33	12	15,5	19	24	30	37	47	58	73
1 750	-	3.09	2.53	2.35	2.13	1.68	1.54	1.37	1.23	1.1	0.98
1 150	-	2.49	2.02	1.83	1.68	1.31	1.2	1.08	0.98	0.88	0.78

Size **535**

n_1 rpm	P_{tN} [hp]										
	i										
	-	8,25	11,7	15,5	19	23,5	30	37	47	58	73
1 750	-	5	4.26	3.64	3.36	3.1	2.41	2.18	2	1,8	1.6
1 150	-	4.01	3.42	2.87	2.64	2.47	1.89	1.7	1.59	1.42	1.27

Size **742**

n_1 rpm	P_{tN} [hp]										
	i										
	-	8,25	11,7	15,5	19	23,5	30	37	47	58	73
1 750	-	7.9	6.85	5.9	5.38	5.03	3.94	3.5	3.25	2.91	2.58
1 150	-	6.41	5.51	4.65	4.29	3.94	3.07	2.77	2.54	2.29	2.03

Consider: for **4** poles $n_1 = 1\ 750$ rpm and for **6** poles $1\ 150$ rpm.

Thermal power P_t can be higher than the nominal P_{tN} , described above, as per the following formula $P_t = P_{tN} \cdot f_t$ where f_t is the thermal factor depending on ambient temperature and type of duty as indicated in the table.

Maximum ambient temperature °F	Duty				
	continuous S1	on intermittent load S3 ... S6 Cyclic duration factor [%] for 60 min running ¹⁾			
		60	40	25	15
104	1	1.18	1.32	1.5	1.7
86	1.18	1.4	1.6	1.8	2
68	1.32	1.6	1.8	2	2.24
50	1.5	1.8	2	2.24	2.5

1) $\frac{\text{Duration of running on load [min]}}{60} \cdot 100$

In general, the combinations foreseen in ch. 9 **do not require thermal power verification**, i.e. the verification that applied power P_1 is less than or equal to thermal power P_t ($P_1 \leq P_t = P_{tN} \cdot f_t$), exception made for those cases indicated by * or ** for which:

* thermal power verification is necessary if, for continuous duty, **the ambient temperature is > 86° F (30 °C)** or running is in **full power**

** thermal power is **always** to be verified.

For **B6** or **B7** mounting position multiply P_{tN} by **0,9**.

Thermal power needs not be taken into account when maximum duration of continuous running time is $0,5 \div 2$ h (from small to large gear reducer sizes) followed by rest periods long enough to restore the gear reducer to near ambient temperature (likewise $0,5 \div 2$ h).

In case of maximum ambient temperature above 104° F (40 °C) or below 32° F (0 °C) consult us.

3.4 - Service factor fs

Service factor fs takes into account the different running conditions (nature of load, running time, frequency of starting, other considerations) to which the gearmotor can be subjected and which must be referred to when performing calculations of gearmotor selection and verification.

Two equivalent methods are here proposed to determine the minimum service factor required by applications:

- **mass acceleration method**: considering the overloads deriving from the system inertia and running conditions (starts per hour, hours per day, expected life);
- **AGMA service factor**, according to AGMA standards (although the gearmotors of the present catalog are not strictly AGMA rated).

Mass acceleration method

For an analytical determination of the required service factor (especially considering the running hours), proceed as stated below and/or consult us

- Calculate the **mass acceleration factor** mj:

where:

$$m_j = \frac{WK_r^2}{WK_s^2}$$

WK_r² [lb ft²] is the external moment of inertia (of mass; couplings, driven machine)
WK_s² reflected to the motor shaft:

$$WK_r^2 = WK_s^2 \cdot \left(\frac{n_2}{n_N}\right)^2$$

WK_s² [lb ft²] is the moment of inertia (of mass) of motor (see ch. 2b);

n₂ [rpm] is output speed of the gearmotor;

n_N [rpm] is nominal speed of the motor (see ch. 2b). As a guideline consider: n_N = 1 750 rpm for 4 poles and n_N = 1 150 rpm for 6 poles;

- Select the proper **overload class** according to the acceleration mass factor mj:

- m_j ≤ 0.3 (uniform load) load classification **I**
- m_j ≤ 3 (moderate overloads) load classification **II**
- m_j ≤ 10 (heavy overloads) load classification **III**

For m_j values larger than **10**, in presence of high values of backlash for kine-matic chain, a specific evaluation has to be carried out: consult us.

- From the **diagram**, according to the overload class, the running time and the starting frequency z, read off the minimum service factor required.

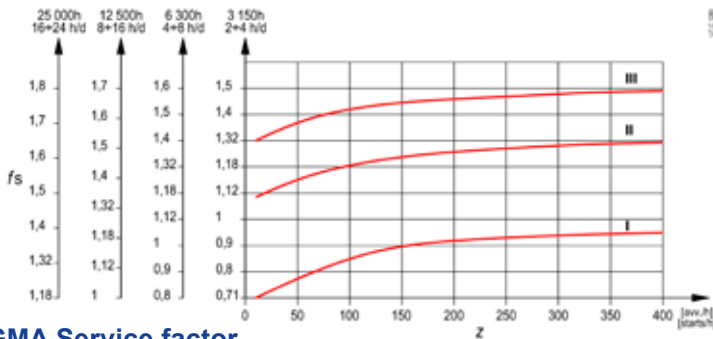

Whenever a **higher reliability degree** is required for the application (e.g.: personnel safety, key importance of the gearmotor to production, particularly difficult maintenance conditions, etc.) multiply fs by **1,25** ÷ **1,4**: consult us.

AGMA Service factor

Service factor

For a proper selection of gearmotor service factor, the magnitude and duration of shock loads, the duration of service per hour, per day, and per week, as well as the required reliability must be determined.

Although the gearmotors of the present catalog are not strictly AGMA rated, nevertheless the following table (gear reducer driven by an electric motor) can be used to select a proper service factor as well.

It is recommended that service factor for unique applications be agreed upon by the end user and the manufacturer.

The following discussion of shock loads and duration of service are provided as a guide to proper classification of applications.

Load classification

Since the gearmotor rating applies to applications involving uniform loads, the magnitude of any recurrent shock loads should be estimated or determined through test by the system designer. The loading conditions may be classified as follows:

- **uniform load**. Recurrent shock loads do not exceed the **nominal** specified input power;
- **moderate shock load**. Recurrent shock loads do not exceed **125** percent of the nominal specified input power;
- **heavy shock load**. Recurrent shock loads do not exceed **150** percent of the nominal specified input power;
- **extreme shock load**. Recurrent shock loads do not exceed **175** percent of the nominal specified input power.

Duration [hours per day]	Service factor			
	Uniform load	Moderate shock	Heavy shock	Extreme shock
Occasional 1/2 hour	(0.75) ¹	(0.90) ¹	1.00	1.25
≤ 3	1.00	1.00	1.25	1.50
3 - 10	1.00	1.25	1.50	1.75
> 10	1.25	1.50	1.75	2.00

1) These service factors should be 1.00 or as agreed by the user and the manufacturer.

Caution: in case of high reliability degree requirements (e.g.: application involving risks for personnel safety) or in presence of high inertia loads or high starts/stops frequency, consult us.

3.5 - Selection

Determining the gearmotor size

- Make available all necessary data: required output power P_2 of gearmotor, speed n_2 , running conditions (nature of load, running time, frequency of starting z , other considerations) with reference to ch. 3.4.
- Determine service factor f_s on the basis of running conditions (ch. 3.4).
- Select the gearmotor size on the basis of n_2 , f_s , P_2 (ch. 3.7).

When for reasons of motor standardization, power P_2 available in catalogue is much greater than the power P_2 required, the gearmotor can be selected on the basis of a lower service factor provided,

$$\left(f_s \cdot \frac{P_2 \text{ required}}{P_2 \text{ available}} \right)$$

it is certain that this excess power

available will never be required and frequency of starting z is low enough not to affect service factor (ch. 3.4).

Calculations can also be made on the basis of torque instead of power; this method is even preferable for low n_2 values.

Verifications

- Verify possible radial load F_{r2} referring to directions and values given in ch. 3.6 and 3.7.
- For the motor, verify frequency of starting z when higher than that normally permissible, referring to directions and values given in ch. 2 cat. TX; this will normally be required for brake motors only.
- When load chart is available, and/or there are overloads – due to starting on full load (especially with high inertias and low transmission ratios), braking, shocks, irreversible or with low reversibility gear reducers in which the worm-wheel becomes driving member due to the driven machine inertia, other static or dynamic causes – verify that the maximum torque peak (ch. 3.9) is always less than T_{2max} (indicated in ch. 3.7); if it is higher or cannot be evaluated – in the above instances – install suitable safety devices so that T_{2max} will never be exceeded.
- In general, thermal power verification (ch. 3.3) is not required for the combinations foreseen in ch.3.7, exception made for those cases inticated by * or ** for which:
 - * thermal power verification is necessary if, for continuous duty, the **ambient temperature is > 86 °F (30 °C)** or running is in **full power**;
 - ** thermal power is **always** to be verified.

Considerations on selection

Motor power

Taking into account the efficiency of the gear reducer, and other drives – if any – motor power is to be as near as possible to the power rating required by the driven machine: accurate calculation is therefore recommended.

The power required by the machine can be calculated, seeing that it is related directly to the power-requirement of the work to be carried out, to friction (starting, sliding or rolling friction) and inertia (particularly when mass and/or acceleration or deceleration are considerable). It can also be determined experimentally on the basis of tests, comparisons with existing applications, or readings taken with amperometers or wattmeters.

An oversized motor would involve: a greater starting current and consequently larger fuses and heavier cable; a higher running cost as power factor ($\cos \varphi$) and efficiency would suffer; greater stress on the drive, causing danger of mechanical failure, drive being normally proportionate to the power rating required by the machine, not to motor power.

Only high values of ambient temperature, altitude, frequency of starting or other particular conditions require an increase in motor power.

Driving machines with high kinetic energy

In presence of driving machines with high inertias and/or speeds, avoid the use of irreversible gearmotors as stopping and braking can cause very high overloads (ch. 3.9).

3.6 - Radial loads (overhung loads OHL) F_{r2} [lbf] on low speed shaft end

Radial loads generated on the shaft end by a drive connecting gearmotor and machine must be less than or equal to those given at ch. 3.7.

Normally, radial loads on low speed shaft end are considerable: in fact there is a tendency to connect the gear reducer to the machine by means of a transmission with high transmission ratio (economizing on the gear reducer) and with small diameters (economizing on the drive, and for requirements dictated by overall dimensions).

Bearing life and wear (which also affects gears unfavourably) and low speed shaft strength, clearly impose limits on permissible radial load.

Permissible radial loads are given in the tables of ch. 3.7 and are referred to gearmotor's output speed n_2 and torque T_2 , considering overhung load acting on centre line of standard low speed shaft end (see ch. 4), in the most unfavourable direction of rotation and angular position of load.

If the exact direction of rotation and angular position of load are known, an increase of permissible radial load may be achieved. If necessary, consult us for the verification of specific instance.

In case of radial load acting in position different from centre line of low speed shaft end, i.e. operating at a distance different from $0,5 \cdot E$, the permissible radial load must be recalculated according to the following formula, verifying not to exceed F_{r2max} max value stated in the table:

$$F_{r2}' = F_{r2} \cdot \frac{E/2 + k}{x + k} \quad [\text{lbf}]$$

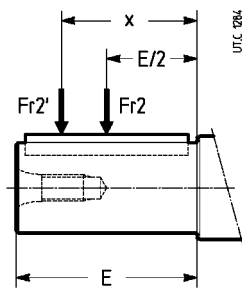

Where:

F_{r2}' [lbf] is the permissible radial load acting at the distance x from shaft shoulder;

F_{r2} [lbf] is the permissible radial load acting on centre line of standard low speed shaft end (see ch. 3.7);

E [in] is standard low speed shaft end length (see following table and ch. 5);

k [in] is given in the table;

x [in] is the distance between the shaft shoulder and the load application point.

		Gear reducer size					
		118	225	325	430	535	742
E	[in]	1.1	1.6	1.6	2.2	2.2	3.2
k	[in]	2.05	2.58	3.05	3.68	4.35	5.24
F_{r2max}	[lbf]	450	600	900	1 250	1 450	1 700

An **axial load** of up 0.2 times the value in the tables of ch. 3.7 is permissible, simultaneously with the radial load.

In case of no radial loads an axial load (not misaligned) of up 0,5 times the value in the tables of ch. 3.7, is permissible.

For higher values and/or **misaligned** axial loads, consult us.

Radial load F_{r2} for most common drives has the following value:

$$F_{r2} = k \cdot \frac{2 \cdot T_2}{d} \quad [\text{N}]$$

where:

T_2 [lbf in] is the torque required by the gearmotor low speed shaft;

d [in] is the pitch diameter;

k is a coefficient which assumes different values according to transmission type:

$k = 1$ for chain drive (lifting in general);



$k = 1.5$ for timing belt drive;

$k = 2.5$ for V-belt drive;

$k = 1.1$ for spur gear pair drive;

$k = 3.55$ for friction wheel drive.

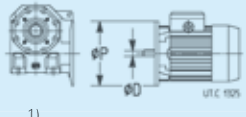

3.7 - Selection tables

Motor power P_1 hp	Output speed n_2 rpm	Output power P_2 hp	Output torque T_2 lbf in	Max output torque T_{2max} lbf in	OHL F_{r2} lbf	Service factor i	f_s	 1)	 2)										
									HB	HBZ									
0,12	19,8	0,08	245	620	600	58	1,6	MR V 225 - 11 x 90 63 A 6 B14	8,6	17,5	22								
	24,5	0,08	210	775	530	47	2,24												
	30,3	0,09	175	865	530	38	3												
	26,1	0,08	185	425	450	44	1,25					MR V 118 - 11 x 90 63 A 6 B14	6,8	16	20				
	32,9	0,08	155	455	425	35	1,8												
	41,1	0,09	130	495	375	28	2,36												
	52,3	0,09	105	530	375	22	3,15												
	67,6	0,09	85	475	355	17	3,55												
	82,1	0,1	75	465	335	14	4												
	105	0,1	60	485	300	11	4,75												
135	0,1	47,3	415	250	8,5	5,3													
192	0,1	34,4	390	224	6	6,7													
0,16	19,8	0,1	325	620	600	58	1,18	MR V 225 - 11 x 90 63 B 6 B14	8,6	18,5	22								
	24,5	0,11	280	775	600	47	1,7												
	30,3	0,11	235	865	530	38	2,24												
	30,2	0,11	230	605	560	58	1,7					MR V 225 - 11 x 90 63 A 4 B14	8,6	17	21				
	37,2	0,11	195	685	475	47	2,24												
	46,1	0,12	165	765	475	38	3												
	26,1	0,1	250	425	450	44	0,95									MR V 118 - 11 x 90 63 B 6 B14	6,8	16,5	21
	32,9	0,11	210	455	450	35	1,32												
	41,1	0,11	175	495	400	28	1,8												
	52,3	0,12	140	530	375	22	2,36												
39,8	0,11	175	370	450	44	1,25	MR V 118 - 11 x 90 63 A 4 B14	6,8	15,5	19,5									
50	0,11	145	400	375	35	1,7													
62,5	0,12	120	435	335	28	2,24													
79,5	0,12	98	465	335	22	3													
103	0,13	77	420	315	17	3,35													
125	0,13	67	405	280	14	3,75													
159	0,14	54	420	250	11	4,5													
206	0,14	42,2	370	212	8,5	5													
292	0,14	30,6	335	190	6	6													
0,25	15,8	0,16	620	865	900	73					1,06	MR V 325 - 14 x 105 71 A 6 B14	14	27	33				
	19,8	0,17	525	1200	900	58	1,5												
	24,5	0,17	445	1470	800	47	2,12												
	30,3	0,18	375	1670	710	38	2,8												
	38,3	0,19	310	1740	670	30	3,55												
	47,9	0,19	255	1620	630	24	4												
	24,5	0,17	435	775	600	47	1,06	MR V 225 - 11 x 90 71 A 6 B14R	8,6	22	28								
	30,3	0,18	370	865	600	38	1,5												
	38,3	0,18	305	945	530	30	1,9												
	30,2	0,17	355	605	560	58	1,06									MR V 225 - 11 x 90 63 B 4 B14	8,6	18,5	22
37,2	0,18	305	685	530	47	1,4													
46,1	0,19	255	765	475	38	1,9													
58,3	0,19	210	820	425	30	2,36													
72,9	0,2	170	760	400	24	2,8													
92,1	0,21	145	715	375	19	3,15													
32,9	0,17	325	455	450	35	0,85	MR V 118 - 11 x 90 71 A 6 B14R					6,8	20	26					
41,1	0,18	270	495	450	28	1,12													
52,3	0,18	220	530	400	22	1,5													
67,6	0,19	180	475	375	17	1,7													

1) For complete designation when ordering see ch. 3.1.

2) Values valid for gearmotor without motor.

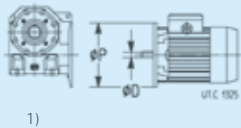

3.7 - Selection tables

Motor power P_1 hp	Output speed n_2 rpm	Output power P_2 hp	Output torque T_2 lbf in	Max output torque T_{2max} lbf in	OHL F_{r2} lbf	Service factor i	f_s	 1)			 2)							
								HB	HB2									
0,25	39,8	0,17	270	370	400	44	0,8	MR V 118 - 11 x 90	63 B	4	B14	6,8	16,5	21				
	50	0,18	225	400	425	35	1,12											
	62,5	0,19	190	435	375	28	1,4											
	79,5	0,19	155	465	335	22	1,9											
	103	0,2	120	420	315	17	2,12											
	125	0,21	105	405	265	14	2,36											
	159	0,21	84	420	236	11	2,8											
	206	0,22	66	370	212	8,5	3,15											
	292	0,22	47,9	335	180	6	4											
	0,33	19,8	0,22	695	1200	900	58		1,18	MR V 325 - 14 x 105	71 B				6	B14	14	29
24,5		0,23	590	1470	800	47	1,6											
30,3		0,24	500	1670	750	38	2,12											
38,3		0,25	410	1740	630	30	2,65											
24		0,22	570	850	850	73	1,12	MR V 325 - 14 x 105	71 A	4	B14	14	27	33				
30,2		0,23	480	1180	800	58	1,6											
37,2		0,24	405	1310	670	47	2											
46,1		0,25	340	1490	600	38	2,65											
58,3		0,26	280	1560	560	30	3,35											
72,9		0,26	230	1430	560	24	3,75											
92,1		0,28	190	1410	500	19	4,5											
30,3		0,23	485	865	600	38	1,12		MR V 225 - 11 x 90	71 B	6				B14R	8,6	24	30
38,3		0,24	400	945	530	30	1,4											
47,9		0,25	330	855	530	24	1,6											
37,2		0,24	400	685	560	47	1,06	MR V 225 - 11 x 90	63 C	4	B14	8,6	20	24				
46,1		0,25	335	765	500	38	1,4											
58,3		0,25	275	820	450	30	1,8											
72,9		0,26	225	760	425	24	2,12											
92,1		0,28	190	715	355	19	2,36											
37,2		0,24	400	685	560	47	1,06		MR V 225 - 11 x 90	71 A	4				B14R	8,6	21	27
46,1		0,25	335	765	500	38	1,4											
58,3		0,25	275	820	450	30	1,8											
72,9		0,26	225	760	425	24	2,12											
92,1		0,28	190	715	355	19	2,36											
113		0,28	155	755	335	15,5	2,8											
146		0,28	125	665	300	12	3,15											
41,1		0,23	360	495	425	28	0,85	MR V 118 - 11 x 90		71 B	6	B14R	6,8	22	28			
52,3		0,24	295	530	425	22	1,12											
67,6		0,25	235	475	400	17	1,32											
82,1		0,27	205	465	335	14	1,5											
50		0,24	300	400	375	35	0,85	MR V 118 - 11 x 90	63 C	4	B14	6,8	18	22				
62,5		0,25	250	435	375	28	1,12											
79,5		0,25	200	465	375	22	1,4											
103		0,26	160	420	335	17	1,6											
125		0,28	140	405	280	14	1,8											
159		0,28	110	420	224	11	2,24											
50		0,24	300	400	375	35	0,85	MR V 118 - 11 x 90	71 A	4	B14R	6,8	19,5	25				
62,5		0,25	250	435	375	28	1,12											
79,5		0,25	200	465	375	22	1,4											
103		0,26	160	420	335	17	1,6											
125	0,28	140	405	280	14	1,8												
159	0,28	110	420	224	11	2,24												
206	0,28	87	370	200	8,5	2,5												
292	0,29	63	335	180	6	3												

1) For complete designation when ordering see ch. 3.1.

2) Values valid for gearmotor without motor.

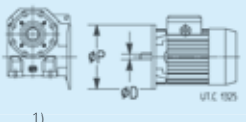
3.7 - Selection tables

Motor power P_1 hp	Output speed n_2 rpm	Output power P_2 hp	Output torque T_2 lbf in	Max output torque T_{2max} lbf in	OHL F_{r2} lbf	Service factor i	f_s							
									2)	HB	HBZ			
0,5	15,8	0,34	1360	3440	1500	73	1,7	MR V 535 - 19 x 200	80 A	6	B5	45	63	71
	19,8	0,36	1140	4820	1500	58	2,5							
	24,5	0,37	960	5170	1500	47	3,35							
	15,8	0,32	1280	1700	1250	73	0,95	MR V 430 - 19 x 200	80 A	6	B5	25	43	51
	19,8	0,34	1080	2340	1250	58	1,32							
	24,5	0,36	920	2660	1060	47	1,8							
	31,1	0,37	750	3020	950	37	2,5							
	38,3	0,38	630	3170	900	30	3,15							
	47,9	0,39	520	3060	850	24	3,75							
	24,5	0,35	890	1470	800	47	1,06	MR V 325 - 14 x 105	71 C	6	B14	14	31	37
	30,3	0,36	755	1670	800	38	1,4							
	38,3	0,38	620	1740	630	30	1,8							
	47,9	0,39	510	1620	630	24	2	MR V 325 - 14 x 105	71 B	4	B14	14	29	35
	30,2	0,35	730	1180	800	58	1,06							
	37,2	0,36	615	1310	750	47	1,32							
	46,1	0,38	515	1490	630	38	1,8							
	58,3	0,39	425	1560	530	30	2,24							
	72,9	0,4	345	1430	500	24	2,5							
	92,1	0,42	290	1410	475	19	3							
	113	0,43	240	1400	450	15,5	3,35							
	146	0,43	190	1280	400	12	4							
	38,3	0,37	605	945	530	30	0,95	MR V 225 - 11 x 90	71 C	6	B14R	8,6	25	32
	47,9	0,38	500	855	530	24	1,06							
	46,1	0,37	510	765	500	38	0,95	MR V 225 - 11 x 90	71 B	4	B14R	8,6	23	29
58,3	0,39	415	820	500	30	1,18								
72,9	0,4	340	760	475	24	1,4								
92,1	0,42	285	715	400	19	1,6								
113	0,42	235	755	355	15,5	1,8								
146	0,43	185	665	315	12	2,12								
210	0,44	135	625	250	8,33	2,65								
67,6	0,38	355	475	355	17	0,85	MR V 118 - 11 x 90	71 C	6	B14R	6,8	24	30	
79,5	0,39	305	465	355	22	0,95								
103	0,4	240	420	335	17	1,06	MR V 118 - 11 x 90	71 B	4	B14R	6,8	21	27	
125	0,42	210	405	300	14	1,18								
159	0,42	170	420	250	11	1,4								
206	0,43	130	370	212	8,5	1,6								
292	0,44	96	335	180	6	2								
0,75	15,8	0,51	2040	3440	1500	73	1,12	MR V 535 - 19 x 200	80 B	6	B5	45	66	75
	19,8	0,54	1710	4820	1500	58	1,7							
	24,5	0,56	1440	5170	1320	47	2,24							
	24	0,54	1410	3390	1320	73	1,5	MR V 535 - 19 x 200	80 A	4	B5	45	62	70
	30,2	0,56	1170	4160	1250	58	2,36							
	37,2	0,58	985	4480	1250	47	2,8							
	47,3	0,59	790	5130	1180	37	4							
	19,8	0,51	1630	2340	1250	58	0,9	MR V 430 - 19 x 200	80 B	6	B5	25	46	55
	24,5	0,54	1380	2660	1180	47	1,18							
	31,1	0,56	1130	3020	1060	37	1,7							
	38,3	0,58	945	3170	850	30	2,12							
47,9	0,59	775	3060	800	24	2,5								

1) For complete designation when ordering see ch. 3.1.

2) Values valid for gearmotor without motor.

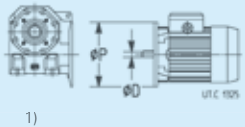
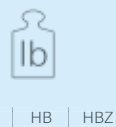

3.7 - Selection tables

Motor power P_1 hp	Output speed n_2 rpm	Output power P_2 hp	Output torque T_2 lbf in	Max output torque T_{2max} lbf in	OHL F_{r2} lbf	Service factor i	f_s								
									2)	HB	HBZ				
0,75	24	0,51	1340	1670	1180	73	0,9	MR V 430 - 19 x 200 80 A 4 B5	25	42	50				
	30,2	0,54	1120	2250	1180	58	1,25								
	37,2	0,56	950	2400	1000	47	1,5								
	47,3	0,58	770	2710	800	37	2,12								
	58,3	0,6	645	2780	750	30	2,65								
	72,9	0,61	530	2670	750	24	3,15								
	92,1	0,64	440	2540	670	19	3,55								
	113	0,65	365	2520	630	15,5	4								
	30,3	0,54	1130	1670	710	38	0,9					MR V 325 - 14 x 105 80 B 6 B14R	14	35	44
	38,3	0,57	930	1740	710	30	1,18								
	47,9	0,58	765	1620	670	24	1,32								
	37,2	0,55	925	1310	670	47	0,9					MR V 325 - 14 x 105 71 C 4 B14	14	30	36
	46,1	0,57	775	1490	670	38	1,18								
	58,3	0,59	635	1560	600	30	1,5								
	72,9	0,6	520	1430	560	24	1,7								
	92,1	0,63	435	1410	500	19	2								
	113	0,64	360	1400	400	15,5	2,24								
	37,2	0,55	925	1310	670	47	0,9					MR V 325 - 14 x 105 80 A 4 B14R	14	31	39
	46,1	0,57	775	1490	670	38	1,18								
	58,3	0,59	635	1560	600	30	1,5								
	72,9	0,6	520	1430	560	24	1,7								
	92,1	0,63	435	1410	500	19	2								
	113	0,64	360	1400	400	15,5	2,24								
	146	0,65	280	1280	375	12	2,65								
210	0,67	200	1170	335	8,33	3,15									
58,3	0,58	625	820	425	30	0,8	MR V 225 - 11 x 90 71 C 4 B14R	8,6	25	31					
72,9	0,59	510	760	425	24	0,9									
92,1	0,63	430	715	400	19	1,06									
113	0,64	355	755	375	15,5	1,25									
146	0,65	280	665	335	12	1,4									
210	0,67	200	625	250	8,33	1,7									
125	0,63	315	405	265	14	0,8	MR V 118 - 11 x 90 71 C 4 B14R	6,8	23	29					
159	0,64	255	420	236	11	0,95									
206	0,65	200	370	212	8,5	1,06									
292	0,67	145	335	190	6	1,32									
1	15,8	0,7	2800	7050	1700	73	1,8	MR V 742 - 24 x 200 100 LA 6 B5R	65	122	136				
	19,8	0,73	2340	9270	1700	58	2,36								
	24,5	0,76	1960	9390	1700	47	3								
	31,1	0,78	1580	11050	1700	37	4,5								
	15,8	0,68	2720	3440	1500	73	0,85	MR V 535 - 19 x 200 80 C 6 B5	45	69	78				
	19,8	0,72	2280	4820	1500	58	1,25								
	24,5	0,75	1920	5170	1500	47	1,7								
	31,1	0,76	1550	5930	1250	37	2,36								
	38,3	0,79	1290	5790	1180	30	2,8								
	15,8	0,68	2720	3440	1500	73	0,85	MR V 535 - 24 x 200 100 LA 6 B5R	45	102	116				
	19,8	0,72	2280	4820	1500	58	1,25								
	24,5	0,75	1920	5170	1500	47	1,7								
	31,1	0,76	1550	5930	1250	37	2,36								
	38,3	0,79	1290	5790	1180	30	2,8								
	24	0,72	1880	3390	1400	73	1,18	MR V 535 - 19 x 200 90 S 4 B5R	45	79	88				
	30,2	0,75	1560	4160	1320	58	1,7								
	37,2	0,77	1310	4480	1180	47	2,12								
	47,3	0,79	1060	5130	1180	37	3,15								
	58,3	0,81	880	5010	1120	30	3,55								
	74,5	0,85	725	4320	1000	23,5	3,75								

Motor (cat.TX) with efficiency value not complying with EISA Premium Efficiency class range.
Nominal power and nameplate data refer to intermittent duty S3 70%.

- 1) For complete designation when ordering see ch. 3.1.
- 2) Values valid for gearmotor without motor.

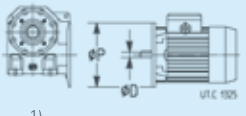
3.7 - Selection tables

Motor power	Output speed	Output power	Output torque	Max output torque	OHL	Service factor	f_s					
									HP	HB	HBZ	
P_1 hp	n_2 rpm	P_2 hp	T_2 lbf in	T_{2max} lbf in	F_{r2} lbf	i						
1	24,5	0,71	1840	2660	1120	47	0,9	MR V 430 - 19 x 200 80 C 6 B5	25	49	58	
	31,1	0,74	1500	3020	1060	37	1,25					
	38,3	0,77	1260	3170	950	30	1,6					
	47,9	0,79	1040	3060	850	24	1,8					
	30,2	0,72	1500	2250	1120	58	0,95	MR V 430 - 19 x 200 90 S 4 B5R	25	59	68	
	37,2	0,75	1260	2400	1000	47	1,18					
	47,3	0,77	1030	2710	900	37	1,6					
	58,3	0,8	860	2780	800	30	2					
	72,9	0,81	705	2670	710	24	2,36					
	92,1	0,85	585	2540	670	19	2,65					
	113	0,87	485	2520	600	15,5	3					
	146	0,88	380	2340	530	12	3,55					
	*	38,3	0,75	1240	1740	630	30	0,9	MR V 325 - 14 x 105 80 C 6 B14R	14	38	47
		46,1	0,76	1030	1490	630	38	0,9	MR V 325 - 14 x 105 71 D 4 B14	14	32	38
		58,3	0,78	845	1560	600	30	1,12				
		72,9	0,8	695	1430	600	24	1,25				
		92,1	0,84	575	1410	500	19	1,5				
		113	0,86	480	1400	425	15,5	1,7				
		146	0,87	375	1280	375	12	2				
		46,1	0,76	1030	1490	630	38	0,9	MR V 325 - 14 x 105 80 B 4 B14R	14	34	43
	58,3	0,78	845	1560	600	30	1,12					
	72,9	0,8	695	1430	600	24	1,25					
	92,1	0,84	575	1410	500	19	1,5					
	113	0,86	480	1400	425	15,5	1,7					
	146	0,87	375	1280	375	12	2					
	210	0,89	270	1170	315	8,33	2,36					
	113	0,85	475	755	335	15,5	0,9	MR V 225 - 11 x 90 71 D 4 B14R	8,6	27	33	
	146	0,86	370	665	315	12	1,06					
	210	0,89	265	625	280	8,33	1,32					
	292	0,89	190	335	160	6	1	MR V 118 - 11 x 90 71 D 4 B14R	6,8	25	31	
1,5	15,8	1,05	4190	7050	1700	73	1,18	MR V 742 - 24 x 200 112 M 6 B5R	65	140	153	
	19,8	1,1	3510	9270	1700	58	1,6					
	24,5	1,14	2940	9390	1700	47	2					
	31,1	1,17	2380	11050	1700	37	3					
	24	1,11	2900	6940	1700	73	1,6	MR V 742 - 24 x 200 90 L 4 B5	65	106	114	
	30,2	1,15	2400	7790	1600	58	2,12					
	37,2	1,19	2010	8140	1500	47	2,5					
	47,3	1,21	1610	9720	1700	37	3,75					
	19,8	1,08	3420	4820	1500	58	0,85					MR V 535 - 24 x 200 112 M 6 B5R
	24,5	1,12	2880	5170	1500	47	1,12					
	31,1	1,14	2320	5930	1400	37	1,6					
	38,3	1,18	1940	5790	1250	30	1,9					
	48,9	1,25	1620	5000	1120	23,5	1,9					
	30,2	1,12	2340	4160	1400	58	1,18	MR V 535 - 19 x 200 80 C 4 B5	45	69	78	
	37,2	1,16	1970	4480	1320	47	1,4					
	47,3	1,19	1580	5130	1180	37	2					
	30,2	1,12	2340	4160	1400	58	1,18	MR V 535 - 24 x 200 90 L 4 B5	45	86	94	
	37,2	1,16	1970	4480	1320	47	1,4					
	47,3	1,19	1580	5130	1180	37	2					
	58,3	1,22	1320	5010	1000	30	2,36					
74,5	1,28	1080	4320	950	23,5	2,5						
92,1	1,3	890	4830	900	19	3,35						
113	1,31	735	4490	900	15,5	3,75						

* On continuous duty with and ambient temperature > 86° F (30 °C) or with full load running, thermal power verification is necessary.



Motor (cat.TX) with efficiency value not complying with EISA Premium Efficiency class range.

Nominal power and nameplate data refer to intermittent duty S3 70%.

1) For complete designation when ordering see ch. 3.1.

2) Values valid for gearmotor without motor.

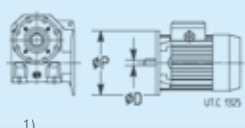
3.7 - Selection tables

Motor power P_1 hp	Output speed n_2 rpm	Output power P_2 hp	Output torque T_2 lbf in	Max output torque T_{2max} lbf in	OHL F_{r2} lbf	Service factor i	f_s	 1)	 2)								
									HB	HBZ							
1,5	* * * * *	31,1	1,11	2250	3020	950	37	0,85	MR V 430 - 19 x 200 90 L 6 B5R	25	62	76					
		38,3	1,15	1890	3170	900	30	1,06									
		47,9	1,18	1550	3060	900	24	1,18									
		60,5	1,25	1300	2870	750	19	1,4									
		37,2	1,12	1900	2400	900	47	0,75									
	*	47,3	1,16	1540	2710	900	37	1,06	MR V 430 - 19 x 200 80 C 4 B5	25	49	58					
		58,3	1,2	1290	2780	900	30	1,32									
		72,9	1,22	1060	2670	750	24	1,5									
		92,1	1,28	875	2540	670	19	1,8									
		113	1,3	725	2520	600	15,5	2									
	*	72,9	1,2	1040	1430	500	24	0,85	MR V 325 - 14 x 105 80 C 4 B14R	14	38	47					
		92,1	1,26	865	1410	475	19	1									
		113	1,29	715	1400	450	15,5	1,12									
		146	1,3	565	1280	425	12	1,32									
		210	1,34	400	1170	335	8,33	1,6									
2	*	15,8	1,4	5590	7050	1700	73	0,9	MR V 742 - 24 x 200 90 LC 6 B5	65	106	120					
		19,8	1,47	4680	9270	1700	58	1,18									
		24,5	1,52	3920	9390	1700	47	1,5									
		31,1	1,56	3170	11050	1700	37	2,24									
		38,3	1,61	2640	10400	1700	30	2,5									
		*	15,8	1,4	5590	7050	1700	73					0,9	MR V 742 - 28 x 250 112 MB 6 B5	68	143	156
			19,8	1,47	4680	9270	1700	58					1,18				
			24,5	1,52	3920	9390	1700	47					1,5				
			31,1	1,56	3170	11050	1700	37					2,24				
			38,3	1,61	2640	10400	1700	30					2,5				
	*	24	1,47	3870	6940	1700	73	1,18	MR V 742 - 24 x 200 90 LB 4 B5	65	106	119					
		30,2	1,53	3200	7790	1700	58	1,6									
		37,2	1,58	2680	8140	1600	47	1,9									
		47,3	1,61	2150	9720	1600	37	2,8									
		58,3	1,66	1790	8900	1500	30	3,15									
		74,5	1,73	1460	7810	1400	23,5	3,15									
		*	31,1	1,53	3090	5930	1400	37					1,18	MR V 535 - 24 x 200 90 LC 6 B5	45	86	100
			38,3	1,57	2590	5790	1320	30					1,4				
			48,9	1,67	2160	5000	1180	23,5					1,5				
			60,5	1,69	1770	5670	1000	19					1,9				
	74,2		1,72	1460	5410	900	15,5	2,24									
	*		30,2	1,5	3130	4160	1320	58	0,85	MR V 535 - 24 x 200 90 LB 4 B5	45	86	99				
			37,2	1,55	2620	4480	1320	47	1,06								
			47,3	1,59	2110	5130	1320	37	1,5								
			58,3	1,63	1760	5010	1180	30	1,8								
			74,5	1,71	1450	4320	1000	23,5	1,9								
		92,1	1,73	1180	4830	900	19	2,5									
		113	1,75	975	4490	850	15,5	2,8									
		150	1,79	750	4710	750	11,7	3,75									
		212	1,82	540	3980	710	8,25	4,5									
**		47,9	1,57	2070	3060	800	24	0,9	MR V 430 - 19 x 200 90 LC 6 B5R					25	66	80	
*	47,3	1,54	2060	2710	800	37	0,8	MR V 430 - 19 x 200 90 LB 4 B5R	25	66	79						
*	58,3	1,6	1720	2780	800	30	1										
*	72,9	1,63	1410	2670	750	24	1,18										
*	92,1	1,71	1170	2540	750	19	1,32										
*	113	1,73	965	2520	600	15,5	1,5										
	146	1,75	755	2340	475	12	1,7										
	210	1,8	540	2130	400	8,33	2,24										

* On continuous duty with and ambient temperature > 86° F (30 °C) or with full load running, thermal power verification is necessary.

** Thermal power is to be verified.



■ Motor (cat.TX) with efficiency value not complying with EISA Premium Efficiency class range.

Nominal power and nameplate data refer to intermittent duty S3 70%.

1) For complete designation when ordering see ch. 3.1.

2) Values valid for gearmotor without motor.

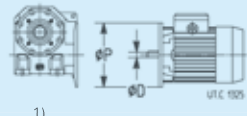
3.7 - Selection tables

Motor power	Output speed	Output power	Output torque	Max output torque	OHL	Service factor	f_s								
									2)	HB	HBZ				
P_1 hp	n_2 rpm	P_2 hp	T_2 lbf in	T_{2max} lbf in	F_{r2} lbf	i									
2,5	19,8	1,84	5850	9270	1700	58	0,95	MR V 742 - 28 x 250 100 LB 6 B5	68	121	134				
	24,5	1,9	4900	9390	1700	47	1,18								
	31,1	1,95	3960	11050	1700	37	1,8								
	38,3	2,01	3300	10400	1700	30	2								
	24	1,84	4840	6940	1600	73	0,95					MR V 742 - 24 x 200 90 LB 4 B5	65	102	116
	30,2	1,92	4000	7790	1700	58	1,25								
	37,2	1,98	3350	8140	1700	47	1,5								
	47,3	2,02	2690	9720	1700	37	2,24								
	58,3	2,07	2240	8900	1400	30	2,5								
	74,5	2,16	1830	7810	1320	23,5	2,65								
	92,1	2,18	1500	9010	1320	19	3,75								
	*	31,1	1,91	3870	5930	1320	37					0,95	MR V 535 - 24 x 200 100 LB 6 B5R	45	98
	*	38,3	1,97	3240	5790	1250	30	1,12							
		48,9	2,09	2700	5000	1180	23,5	1,18							
		60,5	2,12	2210	5670	1060	19	1,6							
		74,2	2,15	1830	5410	900	15,5	1,8							
		98,3	2,21	1410	5620	800	11,7	2,36							
	*	139	2,25	1020	4740	710	8,25	2,8							
		37,2	1,94	3280	4480	1250	47	0,85	MR V 535 - 24 x 200 90 LB 4 B5	45	82	96			
		47,3	1,98	2640	5130	1250	37	1,25							
		58,3	2,03	2200	5010	1180	30	1,4							
		74,5	2,14	1810	4320	1060	23,5	1,5							
		92,1	2,16	1480	4830	900	19	2							
		113	2,19	1220	4490	800	15,5	2,24							
	150	2,24	940	4710	750	11,7	3								
	212	2,27	675	3980	670	8,25	3,55								
**	58,3	1,99	2160	2780	670	30	0,8	MR V 430 - 19 x 200 90 LB 4 B5R	25	62	76				
*	72,9	2,04	1760	2670	710	24	0,9								
	92,1	2,13	1460	2540	670	19	1,06								
	113	2,17	1210	2520	630	15,5	1,18								
	146	2,19	945	2340	560	12	1,4								
	210	2,25	675	2130	400	8,33	1,8								
3	19,8	2,2	7020	9270	1700	58	0,8	MR V 742 - 28 x 250 132 S 6 B5R	68	172	196				
	24,5	2,28	5870	9390	1700	47	1								
	31,1	2,34	4750	11050	1700	37	1,5								
	38,3	2,41	3960	10400	1700	30	1,7								
	24	2,21	5810	6940	1400	73	0,8					MR V 742 - 24 x 200 90 LC 4 B5	65	106	120
	30,2	2,3	4800	7790	1600	58	1,06								
	37,2	2,37	4020	8140	1700	47	1,25								
	47,3	2,42	3220	9720	1700	37	1,9								
	58,3	2,48	2680	8900	1500	30	2,12								
	24	2,21	5810	6940	1400	73	0,8								
	30,2	2,3	4800	7790	1600	58	1,06								
	37,2	2,37	4020	8140	1700	47	1,25								
	47,3	2,42	3220	9720	1700	37	1,9								
	58,3	2,48	2680	8900	1500	30	2,12								
	74,5	2,6	2200	7810	1320	23,5	2,12								
	92,1	2,62	1790	9010	1250	19	3,15								
	113	2,66	1480	7980	1180	15,5	3,35								
	**	38,3	2,36	3880	5790	1180	30	0,95	MR V 535 - 24 x 200 112 M 6 B5R	45	105	124			
	*	48,9	2,51	3230	5000	1120	23,5	0,95							
		60,5	2,54	2650	5670	1060	19	1,32							
		74,2	2,58	2190	5410	950	15,5	1,5							
		98,3	2,65	1700	5620	800	11,7	2							
		139	2,7	1220	4740	670	8,25	2,36							

* On continuous duty with and ambient temperature > 86° F (30 °C) or with full load running, thermal power verification is necessary.

** Thermal power is to be verified.



■ Motor (cat.TX) with efficiency value not complying with EISA Premium Efficiency class range.

Nominal power and nameplate data refer to intermittent duty S3 70%.

1) For complete designation when ordering see ch. 3.1.

2) Values valid for gearmotor without motor.

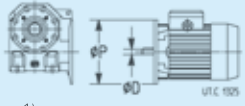
3.7 - Selection tables

Motor power P_1 hp	Output speed n_2 rpm	Output power P_2 hp	Output torque T_2 lbf in	Max output torque T_{2max} lbf in	OHL F_{r2} lbf	Service factor i	f_s	 1)	 2)			
									HB	HBZ		
3	*	47,3	2,38	3170	5130	1180	37	1	MR V 535 - 24 x 200 90 LC 4 B5	45	86	100
	*	58,3	2,44	2640	5010	1120	30	1,18				
	*	74,5	2,56	2170	4320	1060	23,5	1,25				
	*	92,1	2,6	1780	4830	950	19	1,7				
	*	113	2,63	1470	4490	800	15,5	1,8				
	*	47,3	2,38	3170	5130	1180	37	1	MR V 535 - 24 x 200 112 MA 4 B5R	45	113	127
	*	58,3	2,44	2640	5010	1120	30	1,18				
	*	74,5	2,56	2170	4320	1060	23,5	1,25				
	*	92,1	2,6	1780	4830	950	19	1,7				
	*	113	2,63	1470	4490	800	15,5	1,8				
	*	150	2,68	1130	4710	710	11,7	2,5	MR V 430 - 19 x 200 90 LC 4 B5R	25	66	80
	**	212	2,73	810	3980	630	8,25	3				
	**	72,9	2,44	2110	2670	630	24	0,75				
	*	92,1	2,56	1750	2540	600	19	0,9				
	*	113	2,6	1450	2520	560	15,5	1				
*	146	2,63	1130	2340	500	12	1,18	MR V 742 - 28 x 250 112 MC 6 B5	68	139	158	
*	210	2,7	810	2130	425	8,33	1,5					
*	31,1	3,13	6340	11050	1700	37	1,12					
*	38,3	3,21	5280	10400	1700	30	1,25					
*	48,9	3,38	4360	9040	1600	23,5	1,25					
*	60,5	3,44	3580	10600	1500	19	1,8	MR V 742 - 28 x 250 112 M 4 B5	68	141	154	
*	74,2	3,48	2950	9700	1320	15,5	2					
*	30,2	3,07	6400	7790	1250	58	0,8					
*	37,2	3,16	5360	8140	1400	47	0,95					
*	47,3	3,23	4300	9720	1700	37	1,4					
*	58,3	3,31	3580	8900	1600	30	1,6	MR V 535 - 24 x 200 112 MC 6 B5R	45	116	135	
*	74,5	3,46	2930	7810	1500	23,5	1,6					
*	92,1	3,5	2390	9010	1320	19	2,36					
*	113	3,54	1970	7980	1120	15,5	2,5					
*	150	3,6	1510	8510	950	11,7	3,35					
*	212	3,66	1090	7030	900	8,25	3,75	MR V 535 - 24 x 200 112 M 4 B5R	45	118	131	
*	74,2	3,44	2920	5410	800	15,5	1,12					
*	98,3	3,53	2260	5620	800	11,7	1,5					
*	139	3,6	1630	4740	630	8,25	1,8					
**	58,3	3,25	3520	5010	850	30	0,9					
**	74,5	3,42	2890	4320	850	23,5	0,95	MR V 742 - 28 x 250 132 MB 6 B5R	68	216	240	
*	92,1	3,46	2370	4830	850	19	1,25					
*	113	3,51	1950	4490	850	15,5	1,4					
*	150	3,58	1500	4710	710	11,7	1,9					
*	212	3,64	1080	3980	560	8,25	2,24					
5,4	*	60,5	4,64	4830	10600	1500	19	1,32	MR V 742 - 28 x 250 112 MB 4 B5	68	145	165
	*	74,2	4,7	3990	9700	1320	15,5	1,5				
	*	98,3	4,81	3080	10100	1120	11,7	1,9				
	*	139	4,89	2220	8420	900	8,25	2,24				
	*	58,3	4,47	4830	8900	1600	30	1,18				
	*	74,5	4,67	3950	7810	1500	23,5	1,18	MR V 535 - 24 x 200 112 MB 4 B5R	45	122	142
	*	92,1	4,72	3230	9010	1320	19	1,7				
	*	113	4,78	2670	7980	1120	15,5	1,8				
	*	150	4,87	2040	8510	950	11,7	2,5				
	*	212	4,94	1470	7030	900	8,25	2,8				
	*	113	4,73	2640	4490	800	15,5	1	MR V 535 - 24 x 200 112 MB 4 B5R	45	122	142
	*	150	4,83	2030	4710	750	11,7	1,4				
	*	212	4,91	1460	3980	630	8,25	1,6				

* On continuous duty with and ambient temperature > 86° F (30 °C) or with full load running, thermal power verification is necessary.

** Thermal power is to be verified.



■ Motor (cat.TX) with efficiency value not complying with EISA Premium Efficiency class range.

Nominal power and nameplate data refer to intermittent duty S3 70%.

1) For complete designation when ordering see ch. 3.1.

2) Values valid for gearmotor without motor.

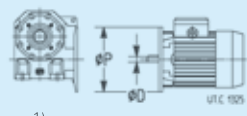
3.7 - Selection tables

Motor power P_1 hp	Output speed n_2 rpm	Output power P_2 hp	Output torque T_2 lbf in	Max output torque T_{2max} lbf in	OHL F_{r2} lbf	Service factor i	f_s	 1)	 2)			
									HB	HBZ		
7,5	** 60,5	6,4	6710	10600	1250	19	1	MR V 742 - 28 x 250 132 MB 6 B5R	68	196	222	
	** 74,2	6,5	5540	9700	1250	15,5	1,06					
	* 98,3	6,7	4280	10100	1180	11,7	1,4					
		139	6,8	3080	8420	850	8,25	1,7				
	* 92,1	6,6	4490	9010	1250	19	1,25	MR V 742 - 28 x 250 112 MC 4 B5	68	141	161	
	* 113	6,6	3700	7980	1250	15,5	1,32					
	 150	6,8	2840	8510	1060	11,7	1,7					
	 212	6,9	2040	7030	850	8,25	2					
	* 92,1	6,6	4490	9010	1250	19	1,25	MR V 742 - 28 x 250 132 M 4 B5R	68	196	220	
	* 113	6,6	3700	7980	1250	15,5	1,32					
	 150	6,8	2840	8510	1060	11,7	1,7					
	 212	6,9	2040	7030	850	8,25	2					
** 150	6,7	2820	4710	600	11,7	1	MR V 535 - 24 x 200 112 MC 4 B5R	45	118	138		
** 212	6,8	2030	3980	530	8,25	1,18						

* On continuous duty with and ambient temperature > 86° F (30 °C) or with full load running, thermal power verification is necessary.

** Thermal power is to be verified.

■ Motor (cat.TX) with efficiency value not complying with EISA Premium Efficiency class range.

Nominal power and nameplate data refer to intermittent duty S3 70%.

1) For complete designation when ordering see ch. 3.1.

2) Values valid for gearmotor without motor.

3.8 - Dimensions

Size **118**

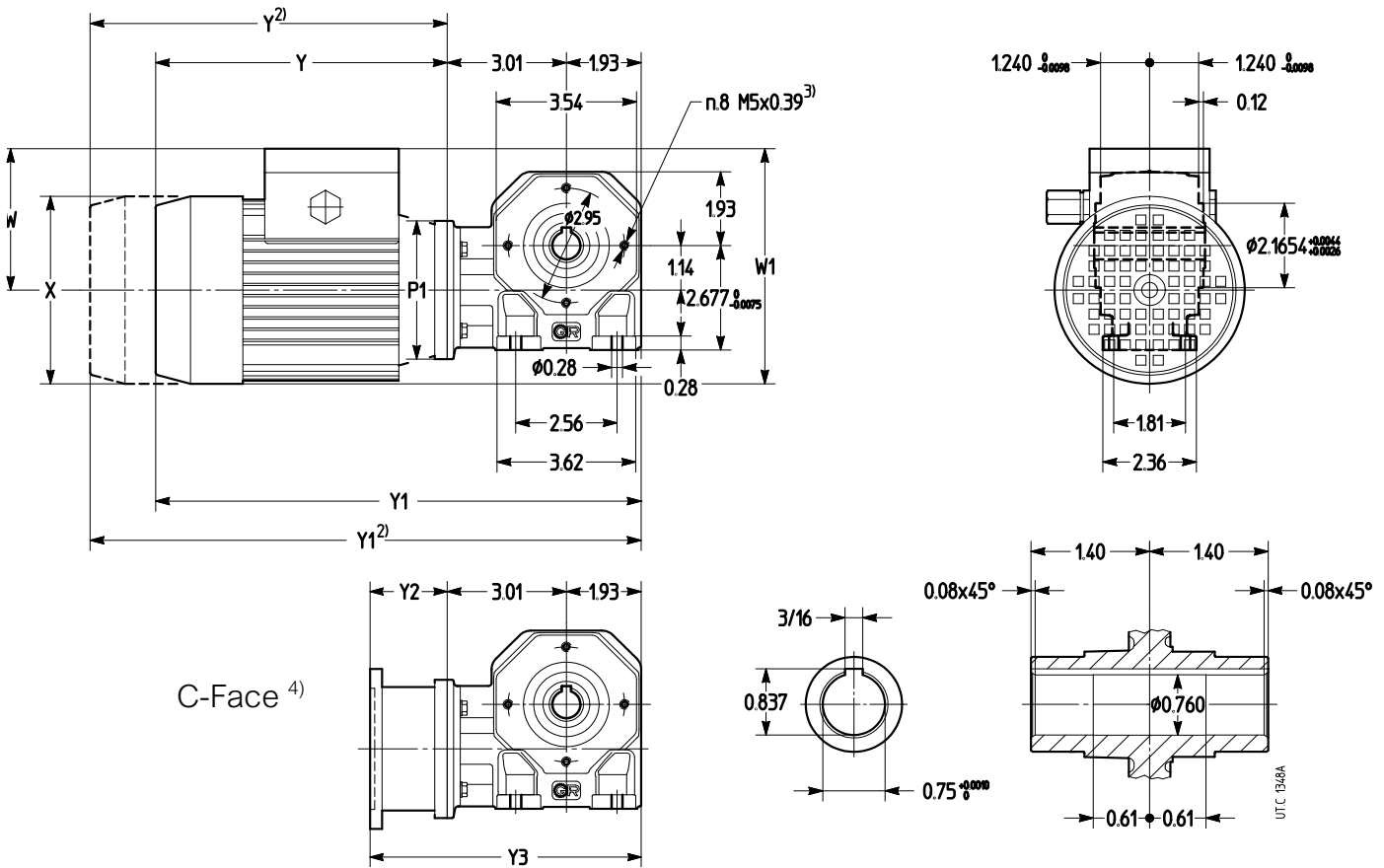

Motor size 1)	P1 Ø	X Ø ≈	Y		Y1		W ≈	W1 ≈	NEMA C-Face adapter 4)		
			≈	2)	≈	2)			Y2	Y3	
63 B14	90	4.84	7.44	9.61	12.4	14.57	3.74	6.18	MPN 63 B14 - 56 5)	2.70	7.64
71 B14R		5.43	8.5	10.94	13.46	15.91	4.41	7.13			

- 1) Motor mounting position (see ch. 2b).
- 2) Values valid for HBZ brake motor.
- 3) No. 4 holes for each of the 2 B14 output flanges.
- 4) Available on request: for further dimensions and details see ch. 4.
- 5) Not available for 63B 6 motor.

3.8 - Dimensions

Size **225**

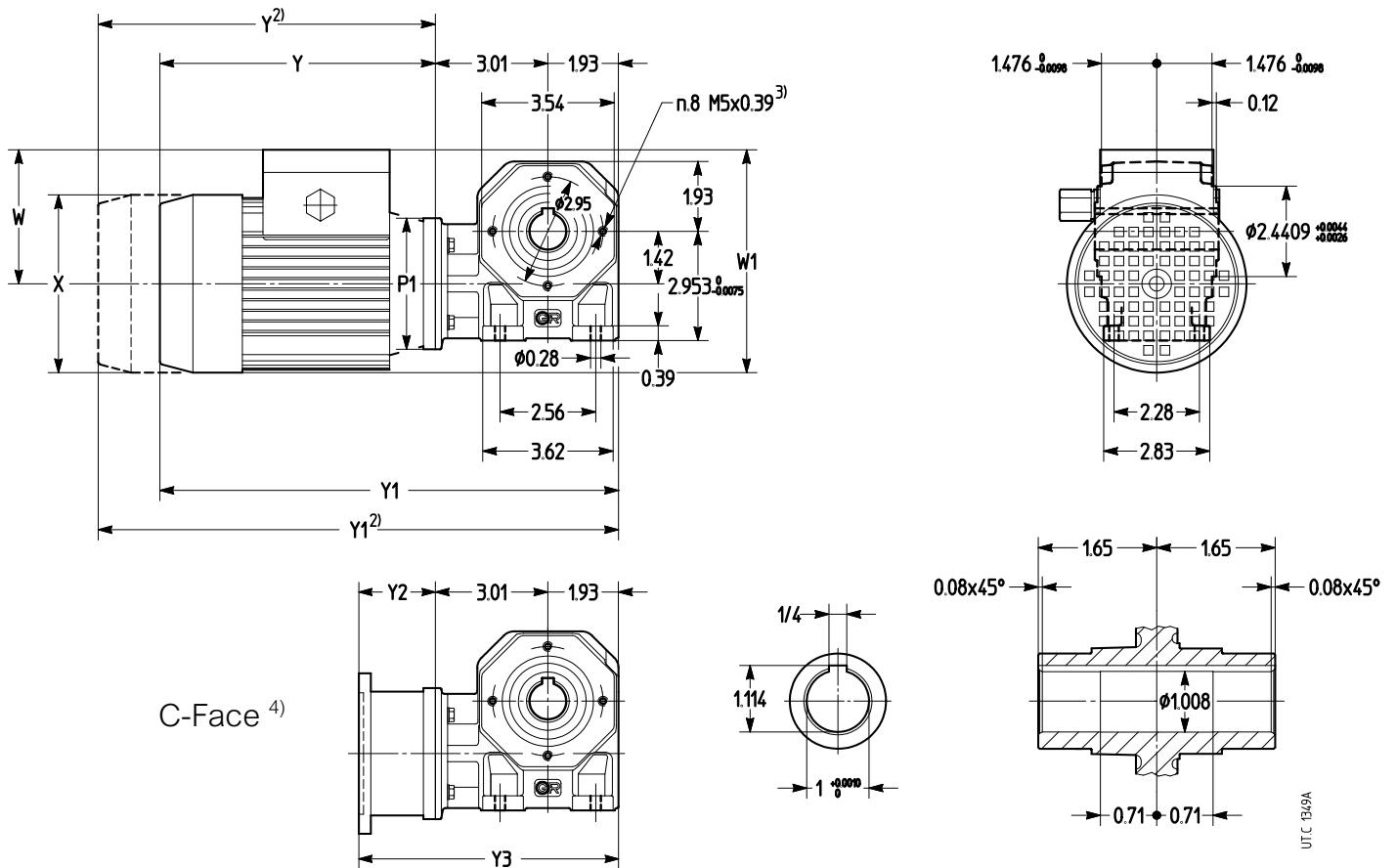

Motor size 1)	P1 Ø	X Ø ≈	NEMA C-Face adapter 4)				W ≈	W1 ≈	Y2	Y3
			Y ≈ 2)	Y1 ≈ 2)	Y2	Y3				
63 B14	90	4.84	7.44	9.61	12.4	14.57	3.74	6.18	2.70	7.64
71 B14R		5.43	8.5	10.94	13.46	15.91	4.41	7.13		

- 1) Motor mounting position (see ch. 2b).
- 2) Values valid for HBZ brake motor.
- 3) No. 4 holes for each of the 2 B14 output flanges.
- 4) Available on request: for further dimensions and details see ch. 4.
- 5) Not available for 63B 6 motor.

3.8 - Dimensions

Size **325**

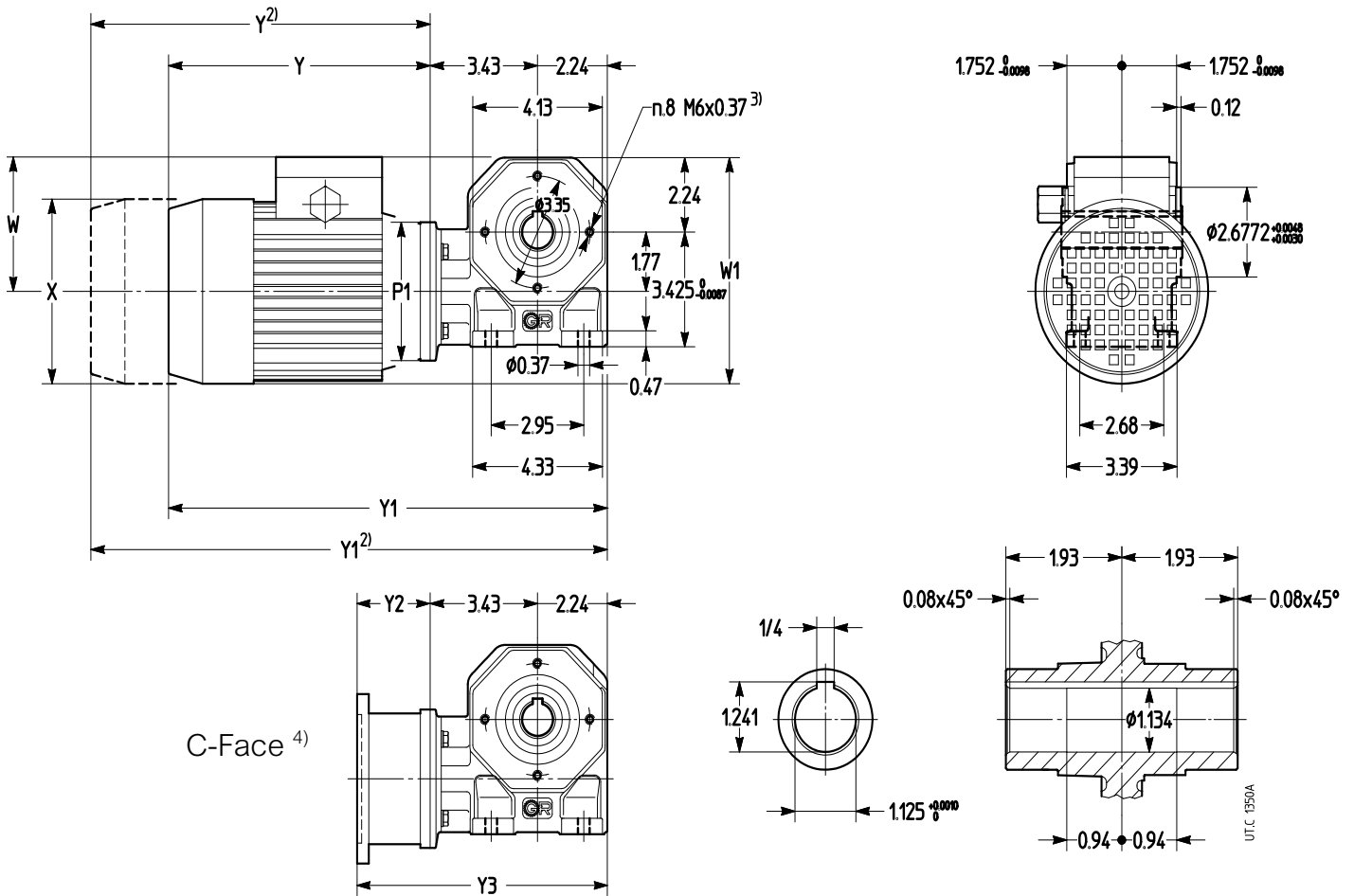

Motor size 1)	P1 Ø	X Ø ≈	Y		Y1		W ≈	W1 ≈	NEMA C-Face adapter 4)		
			≈	2)	≈	2)			Y2	Y3	
71 B14	105	5.43	8.5	10.94	14.17	16.61	4.41	7.13	MPN 63 B14 - 56 C	2.7	8.37
80 B14R		6.14	9.17	11.89	14.84	17.56	4.76	7.83			

- 1) Motor mounting position (see ch. 2b).
- 2) Values valid for HBZ brake motor.
- 3) No. 4 holes for each of the 2 B14 output flanges.
- 4) Available on request: for further dimensions and details see ch. 4.

3.8 - Dimensions

Size **430**

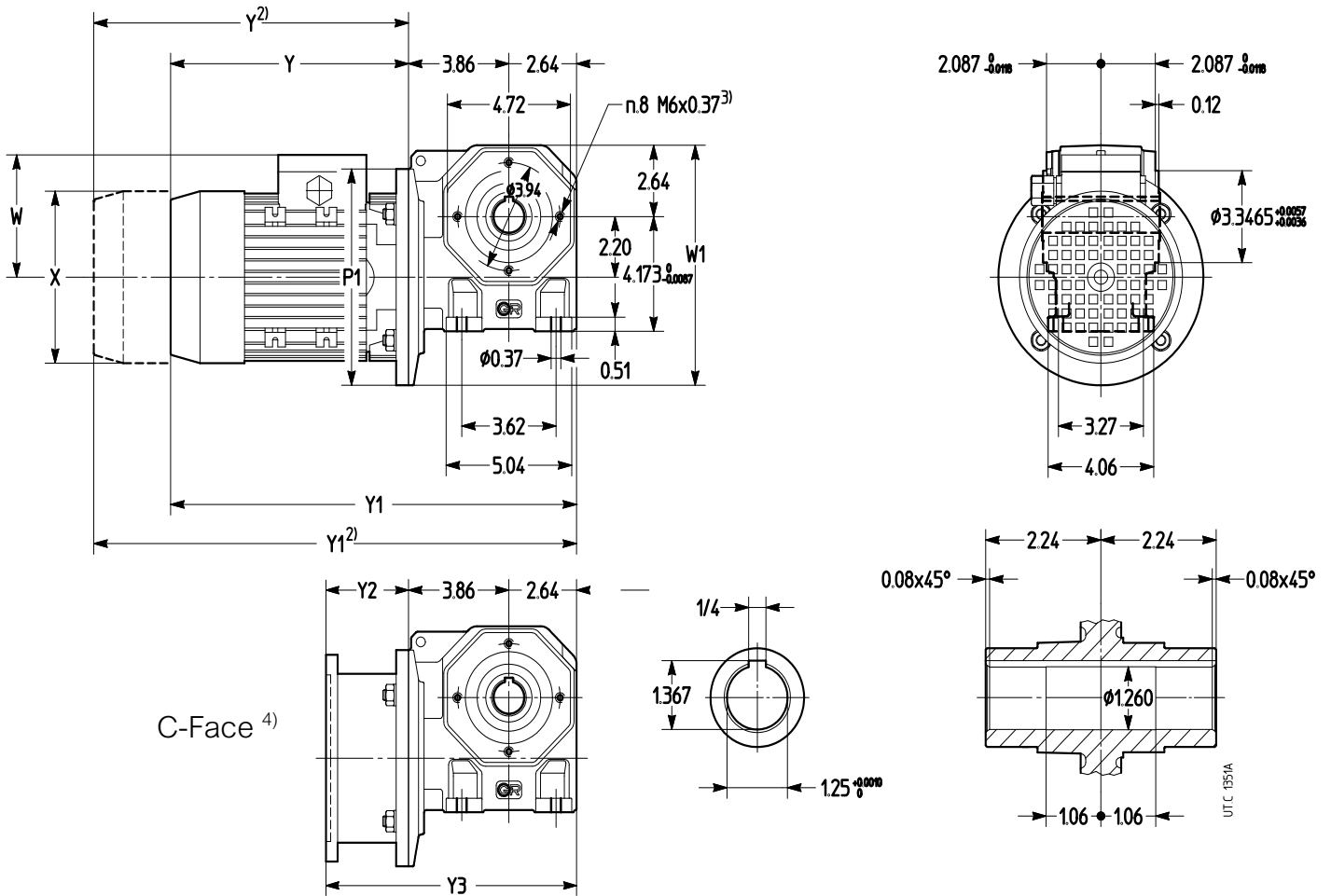

Motor size 1)	P1 Ø	X Ø ≈	Y ≈ 2)	Y1 ≈ 2)	W ≈	W1 ≈	NEMA C-Face adapter 4)				
							Y2	Y3			
80 B5	200	6.14	9.17	11.89	15.67	18.39	4.76	8.78	MPN 80 B5 - 56 C	2.7	9.2
90 L B5R		6.93	11.3	14.41	17.8	20.91	5.55	9.49	MPN 90 B5R - 140 TC		
LB B5R											
LC B5R											

- 1) Motor mounting position (see ch. 2b).
- 2) Values valid for HBZ brake motor.
- 3) No. 4 holes for each of the 2 B14 output flanges.
- 4) Available on request: for further dimensions and details see ch. 4.

3.8 - Dimensions

Size **535**

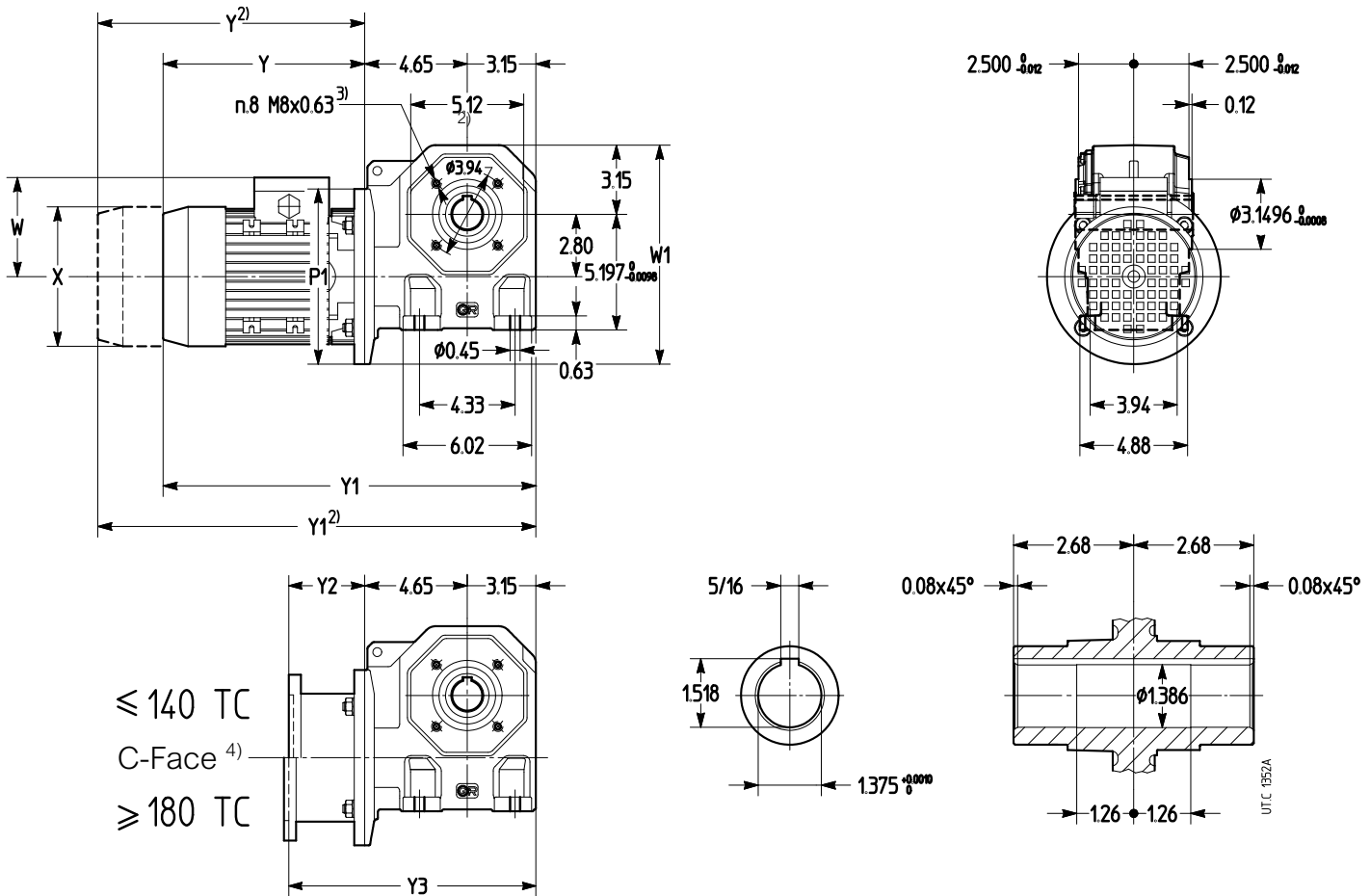

Motor size 1)	P1 Ø	X Ø ≈	Y		Y1		W ≈	W1 ≈	NEMA C-Face adapter 4)		
			≈	2)	≈	2)			Y2	Y3	
80 B5	200	6.14	9.17	11.89	16.97	19.69	4.76	9.88	MPN 80 B5 - 56 C	2.7	10.5
90 S B5		6.93	11.3	14.41	19.09	22.2	5.55		MPN 90 B5 - 56 C		
L B5									MPN 90 B5 - 140 TC		
LB B5									-		
LC B5									MPN 90 B5 - 180 TC		
100 LA B5R		7.64	13.27	17.01	21.06	24.8	5.94	MPN 90 B5 - 180 TC	3.35	11.1	
LB B5R								MPN 90 B5 - 180 TC ⁵⁾			
112 M B5R		8.58	14.25	18.15	22.05	25.94	6.42	10.71	MPN 100 B5R - 180 TC ⁶⁾	4.04	11.8
MC B5R									MPN 100 B5R - 180 TC		

1) Motor mounting position (see ch. 2b).

2) Values valid for HBZ brake motor.

3) No. 4 holes for each of the 2 B14 output flanges.

4) Available on request: for further dimensions and details see ch. 4.

5) Not available for 100LB 6 motor.

6) Not available for 112M 4 motor.

3.8 - Dimensions

Size **742**

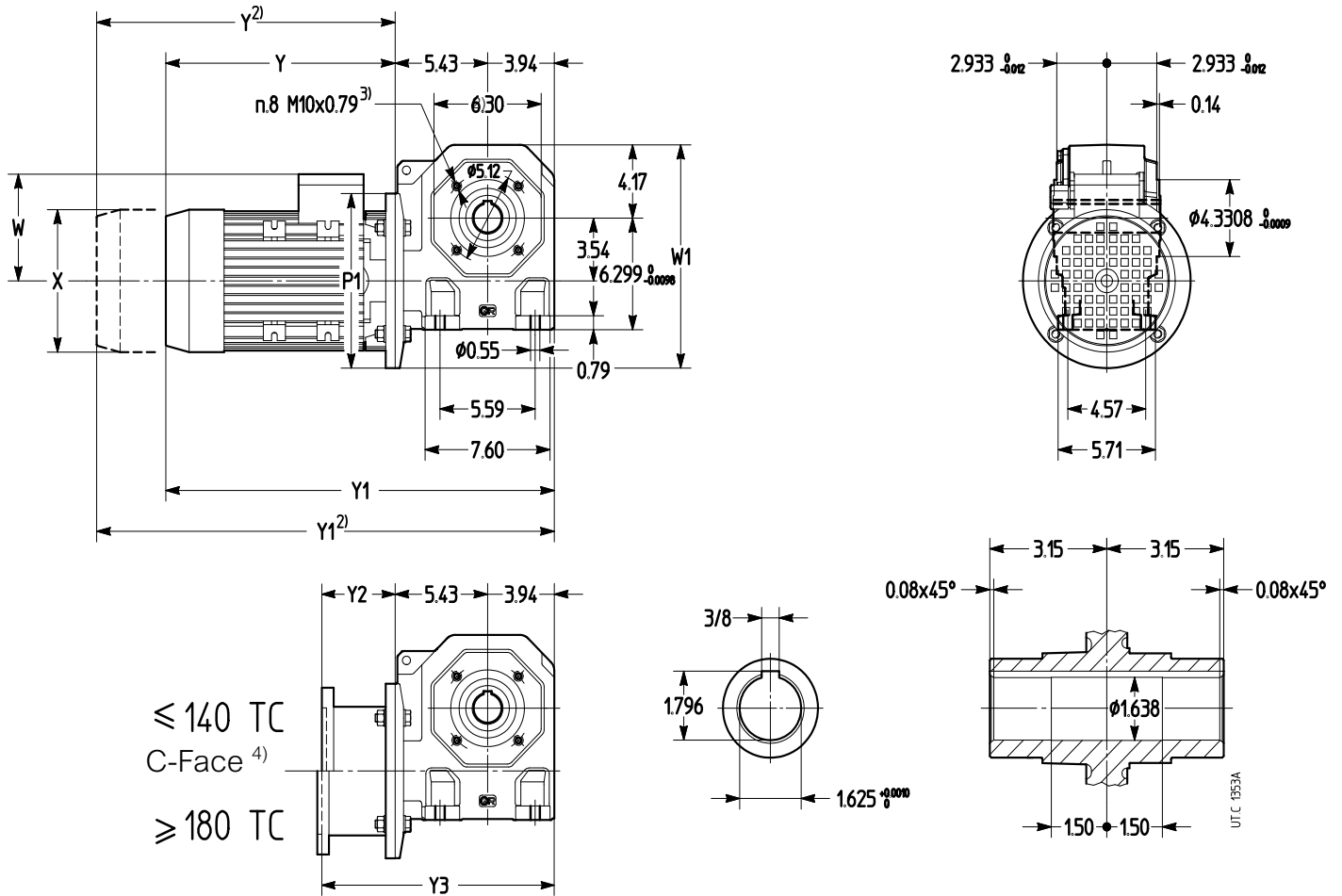

Motor size 1)	P1 Ø	X Ø ≈	Y		W ≈	W1 ≈	NEMA C-Face adapter 4)		
			≈	2)			Y2	Y3	
90 S B5 L B5 LB B5 LC B5	200	6.93	11.3	14.41	5.55	11.65	MPN 90 B5 - 56 C	2.7	12.1
							MPN 90 B5 - 140 C	2.7	12.1
							MPN 90 B5 - 180 C	3.35	12.7
							MPN 90 B5 - 210 C ⁵⁾	4.04	13.4
100 LA B5 LB B5	250	7.24	12.2	15.94	5.94	12.64	MPN 100 B5 - 180 C	3.35	12.7
							MPN 100 B5 - 180 C ⁴⁾	3.35	12.7
112 M B5 MC B5		8.58	13.23	17.13	6.42	12.64	MPN 100 B5 - 210 C ⁵⁾	4.04	13.4
							MPN 100 B5 - 210 C ⁶⁾	4.04	13.4
132 S B5R M B5R MB B5R		10.12	18.9	23.15	7.64	12.8	MPN 100 B5 - 210 C	4.04	13.4
							MPN 100 B5 - 210 C	4.04	13.4
							-	-	-

1) Motor mounting position (see ch. 2b).
 2) Values valid for HBZ brake motor.
 3) No. 4 holes for each of the 2 B14 output flanges.
 4) Available on request: for further dimensions and details see ch. 4

3.9 - Structural and operational details

Worm gear pair

Number of teeth – wormwheel z_2 and worm z_1 – axial module m_x , reference lead angle γ_m , static efficiency η_s of the worm gear pair.

i_N		Gear reducer size					
		118	225	325	430	535	742
6	z_2/z_1	18/3					
	m_x	2.2	–	–	–	–	–
	γ_m	22° 29'					
	η_s	0.71					
8.5	z_2/z_1	17/2	25/3	25/3	25/3	33/4	33/4
	m_x	2.3	2.2	2.8	3.4	3.5	4.5
	γ_m	15° 10'	22° 29'	22° 29'	22° 37'	28° 37'	28° 33'
	η_s	0.65	0.71	0.71	0.71	0.74	0.74
11.8	z_2/z_1	22/2	24/2	24/2	24/2	35/3	35/3
	m_x	1.8	2.3	2.8	3.5	3.3	4.2
	γ_m	13° 29'	15° 10'	15° 10'	15° 07'	19° 52'	20° 28'
	η_s	0.62	0.65	0.65	0.65	0.69	0.7
16	z_2/z_1	28/2	31/2	31/2	31/2	31/2	31/2
	m_x	1.5	1.8	2.3	2.9	3.7	4.7
	γ_m	11° 58'	13° 29'	13° 14'	13° 36'	14° 23'	14° 48'
	η_s	0.6	0.62	0.62	0.63	0.64	0.64
19	z_2/z_1	17/1	38/2	38/2	38/2	38/2	38/2
	m_x	2.3	1.5	1.9	2.4	3.1	3.9
	γ_m	7° 43'	11° 58'	11° 53'	12° 04'	12° 47'	13° 14'
	η_s	0.5	0.6	0.6	0.6	0.61	0.62
23.6	z_2/z_1	22/1	24/1	24/1	24/1	47/2	47/2
	m_x	1.9	2.3	2.8	3.5	2.5	3.2
	γ_m	6° 55'	7° 43'	7° 40'	7° 46'	11° 46'	12° 01'
	η_s	0.48	0.5	0.5	0.5	0.6	0.6
30	z_2/z_1	28/1	30/1	30/1	30/1	30/1	30/1
	m_x	1.5	1.9	2.4	3	3.8	4.8
	γ_m	6° 00'	6° 55'	6° 52'	6° 58'	7° 21'	7° 34'
	η_s	0.45	0.48	0.48	0.48	0.5	0.5
37.5	z_2/z_1	35/1	38/1	38/1	37/1	37/1	37/1
	m_x	1.3	1.5	1.9	2.4	3.1	3.9
	γ_m	5° 14'	6° 00'	6° 00'	6° 03'	6° 25'	6° 38'
	η_s	0.42	0.45	0.45	0.45	0.46	0.47
47.5	z_2/z_1	44/1	47/1	47/1	47/1	47/1	47/1
	m_x	1	1.3	1.6	2	2.5	3.2
	γ_m	4° 30'	5° 14'	5° 10'	5° 16'	5° 54'	6° 02'
	η_s	0.38	0.42	0.42	0.42	0.44	0.45
60	z_2/z_1		58/1	58/1	58/1	58/1	58/1
	m_x	–	1	1.3	1.6	2.1	2.7
	γ_m		4° 30'	4° 25'	4° 32'	5° 07'	5° 15'
	η_s		0.38	0.38	0.38	0.41	0.42
75	z_2/z_1			73/1	73/1	73/1	73/1
	m_x	–	–	1	1.3	1.7	2.1
	γ_m			3° 43'	3° 50'	4° 21'	4° 27'
	η_s			0.34	0.35	0.38	0.38

Low speed shaft angular backlash

A rough guide for low speed shaft angular backlash is given in the table (the worm being held stationary). Values vary according to design and temperature.

1) At a distance of 1 m from the low speed shaft centre, angular backlash in mm is obtained multiplying the table value by 1 000 (1 rad = 3438').

Gear reducer size	Angular backlash [rad] ¹⁾	
	min	max
118	0,0034	0,0132
225	0,0028	0,0112
325	0,0023	0,0090
430	0,0019	0,0075
535	0,0017	0,0067
742	0,0015	0,0056

3.9 - Structural and operational details

Efficiency η

Gear reducer efficiency η is given by P_2 / P_1 ratio (see ch. 3.7). The values obtained will be valid assuming normal working conditions, worm operating as driving member, proper lubrication, adequate running-in (see ch. 4), and a load near to the nominal value.

During the **initial working period** (about 50 hours) and generally at every cold start, efficiency will be lower (by about 12% for worms with $z_1 = 1$; 6% for worms with $z_1 = 2$ and 3% for worms with $z_1 = 3$).

«**Static**» efficiency η_s on starting (see table in the preceding section) is much lower than η (since «starting friction» must be overcome at speed 0); as speed picks up gradually, efficiency will rise correspondingly until the catalogue value is reached.

Inverse efficiency η_{inv} – produced by the wormwheel as driver– is always less than η . It can be calculated approximately as follows:

$$\eta_{inv} \approx 2 - 1 / \eta; \quad \text{likewise:} \quad \eta_{s\ inv} \approx 2 - 1 / \eta_s$$

Irreversibility

The worm gearmotor is **dynamically irreversible** (that is, it ceases to turn the instant the wormshaft receives no further stimulus that would keep the worm itself in rotation e.g. motor torque, inertia from the worm, motor, flywheels, couplings, etc.) when $\eta < 0.5$ as η_{inv} then drops below 0.

This state becomes necessary wherever there is a **need for stopping and holding** the load, even without the aid of a brake. Where continuous vibration occurs, dynamic irreversibility may not be obtainable.

The gearmotor is **statically irreversible** (that is, rotation cannot be imparted by way of the low speed shaft) when $\eta_s < 0.5$.

This is a state **necessary to keep the load at standstill**; taking into account, however, that efficiency can increase with time spent in operation, it would be advisable to assume $\eta_s \leq 0.4$ ($\gamma_m < 5^\circ$).

Where continuous vibration occurs, static irreversibility may not be obtainable.

The gearmotor has **low static reversibility** (i.e. rotation may be imparted by way of the low speed shaft with high torque and/or vibration) when $0.5 < \eta_s \leq 0.6$ ($7^\circ 30' < \gamma_m \leq 12^\circ$).

The gearmotor has **complete static reversibility** (i.e. rotation may be imparted by way of the low speed shaft) when $\eta_s > 0.6$ ($\gamma_m > 12^\circ$).

This state is advisable where there is a **need for easy start-up of the gearmotor by way of the low speed shaft**.

Overloads

Since worm gear pairs are often subject to high static and dynamic overloads by dint of the fact that they are especially suited to bear them, the need arises – more so than with other gear pairs – to verify that such overloads will always remain lower than $T_{2\ max}$ (ch. 3.7).

Overloads are normally generated when one has:

- starting on full load (especially for high inertias and low transmission ratios), braking, shocks;
- irreversible gearmotors or gearmotors with low reversibility in which the worm-wheel becomes driver due to driven machine inertia;
- applied power higher than that required; other static or dynamic causes.

The following general observations on overloads are accompanied by some formulae for carrying out evaluations in certain typical instances.

Where no evaluation is possible, install safety devices which will keep values within $T_{2\ max}$.

Starting torque

When starting on full load (especially for high inertias and low transmission ratios) verify that $T_{2\ max}$ is equal to or greater than starting torque, by using the following formula:

$$T_{2\ start} = \left(\frac{T_{start}}{T_N} \cdot T_2\ available - T_2\ required \right) \frac{WK_R^2}{WK_R^2 + WK_0^2} + T_2\ required$$

where:

T_{start} is the motor starting torque (see ch.2);

T_N is the motor nominal torque (see ch. 2b);

$T_2\ available$ is output torque due to the motor's nominal power;

$T_2\ required$ is torque absorbed by the machine through work and frictions;

WK_0^2 is the moment of inertia (of mass) of the motor (see ch. 2b)

WK_R^2 is the external moment of inertia (of mass; coupling, driven machine) reflected to the motor shaft (see ch. 2b)

NOTE: When seeking to verify that starting torque is sufficiently high for starting, take into account efficiency η_s when evaluating $T_2\ available$, and starting friction, if any, in evaluating $M_2\ required$.

3.9 - Structural and operational details

Stopping machines with high kinetic energy (high moments of inertia combined with high speeds) with or without braking (braking applied to wormshaft, or use of brake motor)

Select a gear reducer with static reversibility ($\eta_s > 0,5$); if using a brake motor, verify braking stress with the following formula:

$$\left(\frac{Tf}{\eta_{s \text{ inv}}} \cdot i + T_2 \text{ required} \right) \frac{WK_R^2}{WK_R^2 + WK_0^2} - T_2 \text{ required} \leq T_{2 \text{ max}}$$

where:

Tf is the braking torque setting (see cat. TX);

$\eta_{s \text{ inv}}$ is static inverse efficiency (see previous heading);

for other symbols see above and ch.1.

Where selection of a statically reversible gearmotor is not possible (i.e. $\eta_s \leq 0,5$) slowing-down should be sufficiently gradual (avoiding application of excessive stress to the unit itself) as to ensure that:

$$0.373 \cdot WK_L^2 \cdot \alpha_2 - T_2 \leq T_{2 \text{ max}}$$

where:

WK_L^2 [lb ft²] is the moment of inertia (of mass) of the driven machine referred to the gear motors low speed shaft;

T_2 [N m] is torque absorbed by the machine through work and friction;

α_2 [rad/s²] is the low speed shaft's angular deceleration; this may be reduced by electric deceleration ramps, lowering of braking torque when braking systems are in use, etc.

α_2 may be arrived at theoretically (within broadly safe limits) or experimentally (by testing against stopping time and distance etc.).

If a brake motor is in use, the following formula may be used for a safe evaluation of α_2 :

$$\alpha_2 = \frac{T_{\text{brake}}}{0.373 \cdot WK_L^2 \cdot i}$$

in which the motor is presumed without load and subject to its braking torque setting T_{brake} [lbf in] (see cat. TX).

Operation with brake motor

Stating time t_a and revolutions of motor φ_{a1}

$$t_a = \frac{(WK_0^2 + WK_R^2) \cdot n_1}{9,55 \left(T_{\text{start}} - \frac{T_2 \text{ required}}{i \cdot \eta} \right)} \text{ [s];} \quad \varphi_{a1} = \frac{t_a \cdot n_1}{19,1} \text{ [rad]}$$

Braking time t_b and revolutions of motor φ_{b1}

$$t_b = \frac{(WK_0^2 + WK_R^2) \cdot n_1}{9,55 \left(Mb + \frac{T_2 \text{ required} \cdot \eta_{\text{inv}}}{i} \right)} \text{ [s];} \quad \varphi_{b1} = \frac{t_b \cdot n_1}{19,1} \text{ [rad]}$$

for symbols see above.

With the gear reducer run in and operating at normal running temperature — assuming a regular air-gap and ambient humidity and utilizing suitable electrical equipment — repetition of the braking action, as affected by variation in temperature of the brake and by the state of wear of friction surface, is approx $\pm 0,1 \cdot \varphi_{f1}$.

During warm-up (0,5 ÷ 2 h, small through to large sizes), braking times and distances tend to increase to the point of stabilizing at or around values corresponding to rated catalogue efficiency.

3.9 - Structural and operational details

Fixing bolt dimensions for gear reducer feet

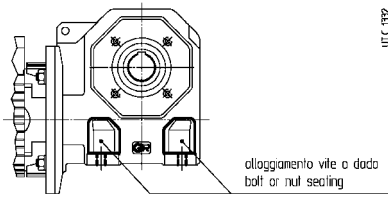

Gear reducer size	Bolt	
	ANSI B18.2.1 class 5	UNI 5737-88 UNI 5739-88 class 8.9
118	1/4 - 20 × 3/4	M 6 × 18
225	1/4 - 20 × 1	M 6 × 25
325	5/16 - 18 × 1¼	M 8 × 35
430	5/16 - 18 × 1½	M 8 × 40
535	3/8 - 16 × 2	M10 × 50
742	7/16 - 14 × 2	M12 × 60

Maximum bending moment of flange MR

In case of assembly of motors supplied by the customer, verify that the static bending moment T_b generated by motor weight on the counter flange of gear reducer is lower than the value allowed T_{bmax} , stated in the table:

$$T_b \leq T_{bmax}$$

where:

$$T_b = G \cdot X / 1000 \text{ [lbf in]}$$

G [lbf] motor weight

X [in] distance from motor center of gravity from flange surface

Very long and thin motors, though with bending moments within the prescribed limits, may generate anomalous vibrations during the operation. In these cases it is necessary to foresee a proper additional motor support (see motor specific documentation).

Loads higher than permissible loads may be present in dynamical applications where the gearmotor is subjected to translations, rotations or oscillations (e.g.: **shaft mounting arrangements**): consult us for the study of every specific case

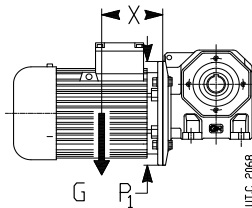

Max allowable bending T_{bmax}

Gear reducer size	P_1	T_{bmax}
	\varnothing	lbf in
118	90	500
225	90	500
325	105	800
430	200	2 500
535	200	4 000
742	200 250	4 000 8 000

Accessories and non-standard designs

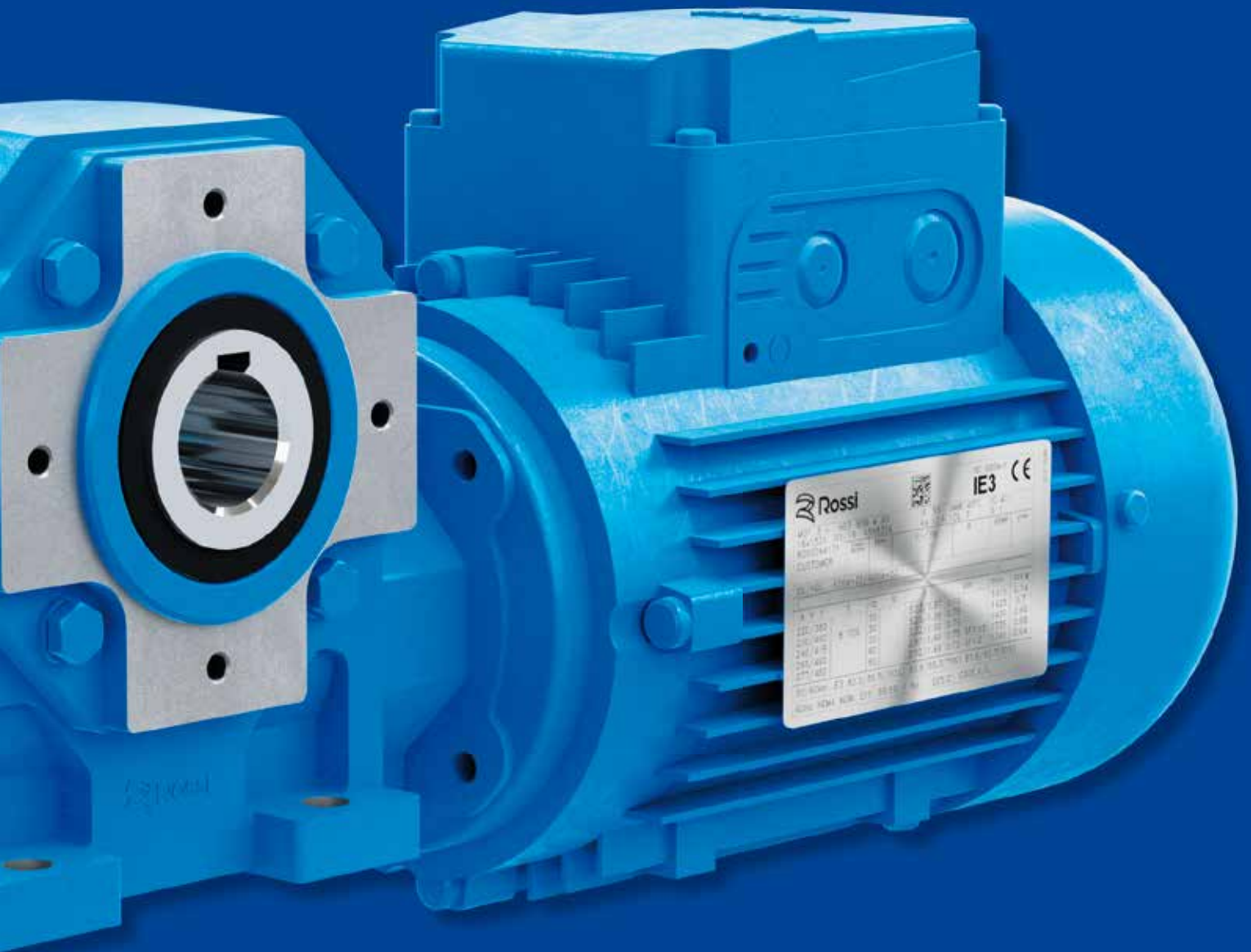



Section content

4.1	Low speed shafts	48
4.2	Flange	48
4.3	Shaft mounting arrangements	49
4.4	Hollow low speed shaft STANDARDFIT protection	49
4.5	NEMA C-Face adapter	50

4 - Accessories and non-standard designs

4.1 - Low speed shafts

The accessory is supplied fitted onto the gear reducer. If not differently stated, the standard mounting position for the low speed shaft end is on gear reducer right hand side – B3 mounting position – seen from motor side. For reverse mounting, specify in designation «**mounted on opposite side**».

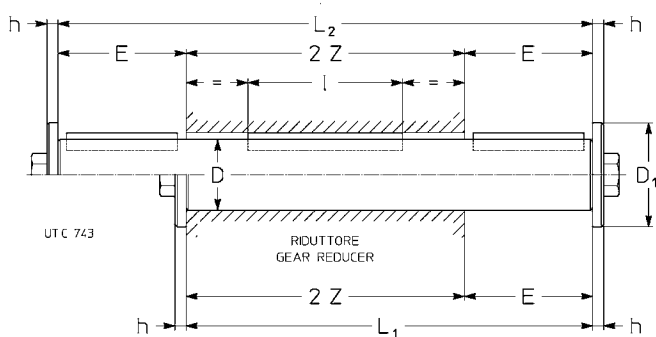

Gear reducer size	U	V	Linguetta esterna External key	D ₁	h	L ₁	L ₂	I	2 Z	Vite Bolt	Massa Mass	
	∅ h7		b × h × l							ANSI B18.2.1	Normale Stand. lb	Bisp. Doubl. extens. lb
118	0.75 ⁺⁰ _{-0.0005}	1.19	3/16 × 3/16 × 1	1.1	0.16	3.98	5.17	1.5	2.8	1/4 – 20 × 3/4	0.46	0.62
225	1 ⁺⁰ _{-0.0005}	1.625	1/4 × 1/4 × 1¼	1.38	0.2	4.93	6.56	2.44	3.31	3/8 – 16 × 1	1.01	1.34
325	1.125 ⁺⁰ _{-0.0005}	1.625	1/4 × 1/4 × 1¼	1.38	0.2	5.48	7.11	2.44	3.86	3/8 – 16 × 1	1.46	1.9
430	1.25 ⁺⁰ _{-0.0005}	2.25	1/4 × 1/4 × 1 7/8	1.85	0.2	6.74	8.99	2.25	4.49	1/2 – 13 × 1¼	2.12	2.91
535	1.375 ⁺⁰ _{-0.0005}	2.25	3/16 × 3/16 × 1 13/16	1.85	0.2	7.6	9.85	2.37	5.35	1/2 – 13 × 1¼	2.98	3.91
742	1.625 ⁺⁰ _{-0.0005}	3.25	3/8 × 3/8 × 2 5/8	2.24	0.24	9.55	12.8	3.5	6.3	5/8 – 11 × 1½	5.2	7

The shoulder outer diameter of the part, or of spacer abutting with the gear reducer must be $(1,25 \div 1,4) \cdot D$.
Supplementary description when ordering by **designation: standard**, or **double extension low speed shaft**.

4.2 - Flange

B5 flange having clearance holes and spigot «recess».

Available in two different options with different mating dimensions: **B5 flange** and **B5 flange Type B**.

The accessory is supplied fitted onto the gear reducer. If not differently stated, the standard mounting position is on gear reducer right hand side – B3 mounting position – seen from motor side. For reverse mounting, specify in designation «**mounted on opposite side**».

Locking adhesives are recommended both around threads and on mating surfaces.

4 - Accessories and non-standard designs

B5 flange

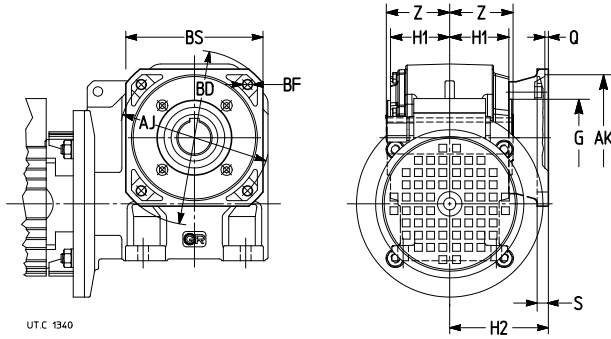

Gear reducer size	BF	G	H1		H2		AJ	AK	BD	Q	S	BS	Z	Mass	
	Ø	Ø	in		in		Ø	Ø	Ø	in	in	in	in		in
118	0.28	2.17	1.240	⁺⁰ _{-0.0098}	2.677	⁺⁰ _{-0.0118}	3.94	3.150	^{+0,0012} ₊₀	4.72	0.16	0.39	3.74	1.4	1.1
225	0.28	2.44	1.476	⁺⁰ _{-0.0098}	2.913	⁺⁰ _{-0.0118}	3.94	3.150	^{+0,0012} ₊₀	4.72	0.16	0.39	3.74	1.65	1.1
325	0.37	2.68	1.752	⁺⁰ _{-0.0098}	3.268	⁺⁰ _{-0.0138}	4.53	3.740	^{+0,0014} ₊₀	5.51	0.16	0.43	4.33	1.93	1.8
430	0.37	3.35	2.087	⁺⁰ _{-0.0118}	3.307	⁺⁰ _{-0.0138}	5.12	4.331	^{+0,0014} ₊₀	6.3	0.18	0.47	4.92	2.24	2.2
535	0.45	3.15	2.5	⁺⁰ _{-0.0118}	4.134	⁺⁰ _{-0.0138}	6.50	5.118	^{+0,0016} ₊₀	7.87	0.18	0.55	5.98	2.68	4
742	0.55	4.33	2.933	⁺⁰ _{-0.0118}	4.606	⁺⁰ _{-0.0138}	8.47	7.087	^{+0,0016} ₊₀	9.84	0.2	0.63	7.72	3.15	7

B5 flange type B

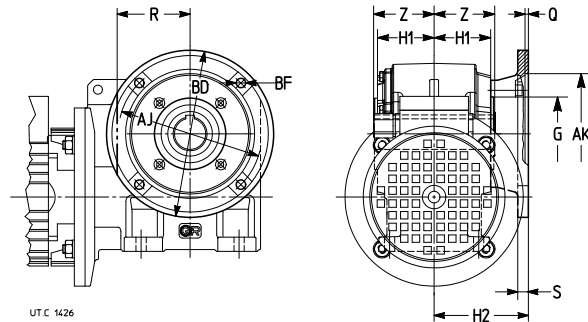

Gear reducer size	BF	G	H1		H2		AJ	AK	BD	Q	R	S	Z	Mass	
	Ø	Ø	in		in		Ø	Ø	Ø	in	in	in	in		in
118	0.37	2.17	1.240	⁺⁰ _{-0.0098}	2.835	⁺⁰ _{-0.0118}	3.43	2.362	^{+0,0012} ₊₀	4.33	0.2	–	0.35	1.4	1.8
225	0.45	2.44	1.476	⁺⁰ _{-0.0098}	3.425	⁺⁰ _{-0.0138}	3.54	2.756	^{+0,0012} ₊₀	4.92	0.2	–	0.39	1.65	2.2
325	0.45	2.68	1.752	⁺⁰ _{-0.0098}	3.346	⁺⁰ _{-0.0138}	5.91	4.528	^{+0,0014} ₊₀	7.09	0.2	3.15	0.43	1.93	3.7
430	0.55	3.35	2.087	⁺⁰ _{-0.0118}	4.016	⁺⁰ _{-0.0138}	6.5	5.118	^{+0,0016} ₊₀	7.87	0.2	3.58	0.47	2.24	5.3
535	0.55	3.15	2.5	⁺⁰ _{-0.0118}	4.409	⁺⁰ _{-0.0138}	6.93	5.984	^{+0,0016} ₊₀	8.27	0.24	–	0.55	2.68	6.4
742	0.55	4.33	2.933	⁺⁰ _{-0.0118}	5.276	⁺⁰ _{-0.0157}	9.06	6.693	^{+0,0016} ₊₀	11.02	0.24	4.76	0.63	3.15	12.8

Supplementary description when ordering by **designation: flange B5 or B5 flange type B.**

In case of separate order from the gear reducer's one, the accessory designation must include the catalog and gear reducers size data.

4.3 - Shaft-mounting arrangements
Reaction bolt using disc springs

Semi-flexible and economical reaction arrangement, with bolt using disc springs.

IMPORTANT: Comply with recommendations at ch.12 for shaft mounting.

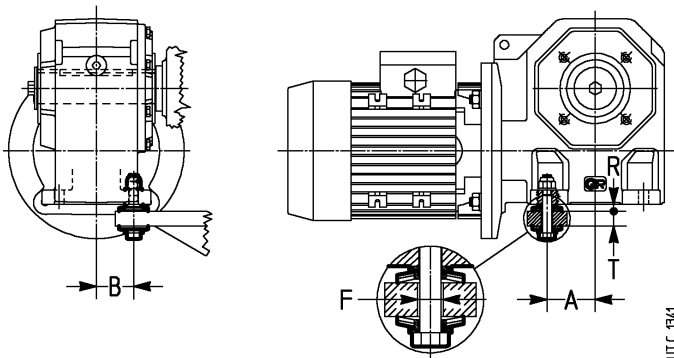

Gear red. size	A	B	Bolt	Disc spring	T	F Ø	R	$M_2 \leq$ 1)
118	1.28	0.91	M6 × 40	A 18 n.2	0.31 ÷ 0.39	0.31	0.19	—
225	1.28	1.14	M6 × 40	A 18 n.2	0.31 ÷ 0.39	0.31	0.19	—
325	1.48	1.34	M8 × 55	A 25 n.2	0.39 ÷ 0.55	0.43	0.26	—
430	1.81	1.63	M8 × 55	A 25 n.2	0.39 ÷ 0.55	0.43	0.26	—
535	2.17	1.97	M12 × 70*	A 35,5 n.2	0.55 ÷ 0.67	0.79	0.35	2 800
742	2.8	2.28	M12 × 90	A 35,5 n.3	0.71 ÷ 0.98	0.79	0.53	5 300

1) For higher M_2 values, utilize 2 reaction bolts or the torque arm (see below).
 * Modified bolt.

Supplementary description when ordering by **designation: reaction bolt using disc springs.**

Torque arm

Reaction arrangement using torque arm, fitted onto B14 flange, with plastic damping bush (not present for sizes 118, 225). The accessory, including fixing bolts, is supplied not assembled. Fitting towards motor is not possible.

IMPORTANT: comply with recommendations at ch. for shaft mounting.

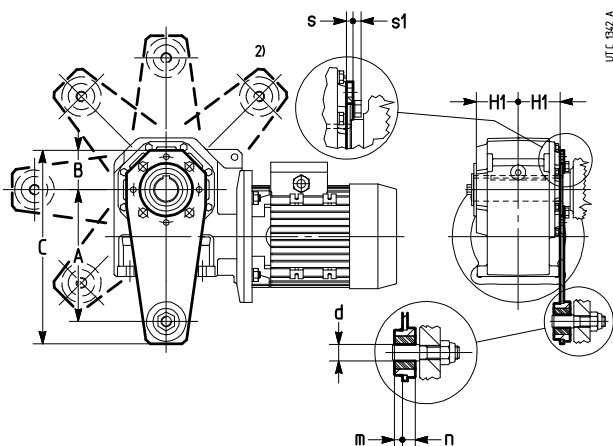

Gear red. size	A	B	C	d Ø	H1	m	n Ø	s	s1	$M_2 \leq$ ≈
118	3.94	1.77	6.18	0.315 ^{+0,0035} ₊₀	1.24 ⁺⁰ _{-0,0098}	0.2	0.35	0.16	0.19	95
225	3.94	1.77	6.18	0.315 ^{+0,0035} ₊₀	1.476 ⁺⁰ _{-0,0098}	0.2	0.35	0.16	0.19	95
325	5.91	2.07	9.06	0.394 ^{+0,0035} ₊₀	1.752 ⁺⁰ _{-0,0098}	0.28	0.51	0.24	0.22	150
430	7.87	2.36	11.57	0.787 ^{+0,0051} ₊₀	2.087 ⁺⁰ _{-0,0118}	0.37	0.61	0.24	0.22	180
535	7.87	2.36	11.57	0.787 ^{+0,0051} ₊₀	2.5 ⁺⁰ _{-0,0118}	0.37	0.61	0.24	0.3	335
742	9.84	3.15	14.33	0.787 ^{+0,0051} ₊₀	2.933 ⁺⁰ _{-0,0118}	0.37	0.61	0.24	0.36	670

1) Plastic damping bush not present.
 2) Position not possible for size 430.

Supplementary description when ordering by **designation: torque arm.**

4 - Accessories and non-standard designs

4.4 - Hollow low speed shaft **STANDARDFIT** protection

Protection hollow low speed shaft free area, made of plastic (polypropilene PP material color black)

The accessory is supplied disassembled and complete with fastening screws. We recommend the use of locking adhesive on the screws.

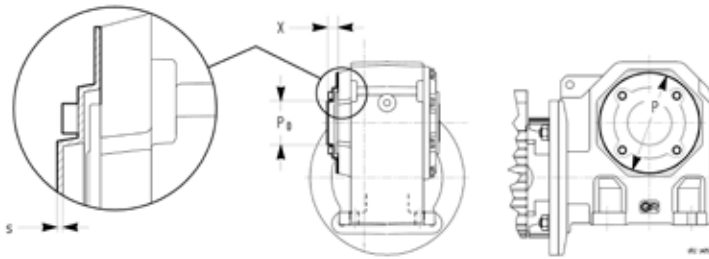

Gear reducer size	P	P ₀	X	S	Screws	T _{tightening} 2)
	Ø	Ø			UNI 5931	lbf in
118, 225	3.54	1.89	0.81	0.059 +0,0012 +0	M5×14	13,5
325	4.13	1.97	0.81	0.063 +0,0012 +0	M6×18	25
430	4.72	2.40	0.94	0.067 +0,0012 +0	M6×18	25
535¹⁾	4.72	2.40	0.94	0.067 +0,0012 +0	M8×20	56
742	6.30	3.07	1.08	0.071 +0,0012 +0	M10×20	109

1) For size 535, gear reducer P dimensions is equal to 5.12 in.

2) Tightening torque.

Non standard design code for designation:

Hollow low speed shaft **STANDARDFIT** protection

In case of separate order from the gear reducer's one, the accessory designation must include the catalog and gear reducers size data.

4.5 - NEMA C-Face adapter

Cast iron casing, device transforming gearmotor IEC input side into NEMA C-Face mating dimensions (see ch. 10 for possible combinations).

Designation code for **ordering** and dimensions as per table below.

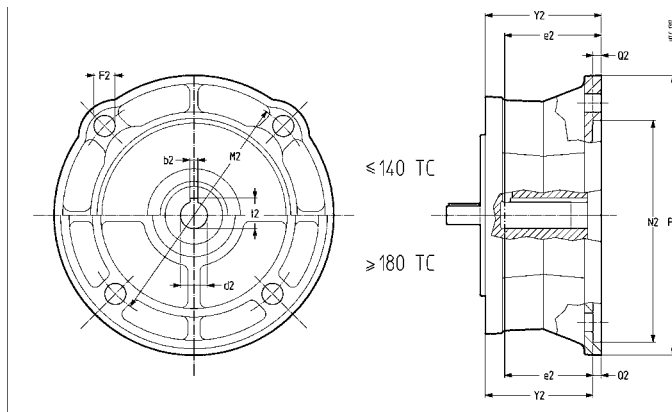

Designation code	NEMA C-Face input side frame size	U1 Ø	V1	S1	t1	BF1 Ø	AJ1 Ø	AK1 Ø	BD1 Ø	Q1	Y2	Weight lb
MPN 63 B14 - 56 C	56 C	0.625	2.06	0.188	0.709	0.43	5.875	4.5	6.5	0.2	2.7	5.6
MPN 71 B14 - 56 C												5.9
MPN 80 B5 - 56 C												9.6
MPN 90 B5 - 56 C												9.8
MPN 90 B5 - 140 TC	140 TC	0.875	2.12	0.188	0.964	0.43	5.875	4.5	6.5	0.2	2.7	9.6
MPN 90 B5R - 140 TC												9.4
MPN 90 B5 - 180 TC	180 TC	1.125	2.62	0.25	1.241	0.56	7.25	8.5	9	0.22	3.35	17.1
MPN 90 B5R - 180 TC												16.9
MPN 100 B5 - 180 TC												20.5
MPN 100 B5 - 210 TC	210 TC	1.375	3.12	0.312	1.518	0.56	7.25	8.5	9	0.22	4.04	23.9
MPN 100 B5R - 210 TC												20.3

Installation and maintenance





Section content

5.1	General	54
5.2	Machine shaft	55
5.3	Shaft-mounting arrangements	55
5.4	IEC frame motor mounting or replacement	55

5 -Installation and maintenance

5.1 - General

Be sure that the structure on which gearmotor is fitted is plane, levelled and sufficiently dimensioned in order to assure fitting stability and vibration absence, keeping in mind all transmitted forces due to the masses, to the torque, to the radial and axial loads.

Position the gearmotor so as to allow a free passage of air for cooling both gear reducer and motor (especially at motor fan side).

Avoid: any obstruction to the air-flow; heat sources near the gear reducer that might affect the temperature of cooling-air and of gear motor for radiation; insufficient air recycle or any other factor hindering the steady dissipation of heat.

Mount the gearmotor so as not to receive vibrations.

When external loads are present use pins or locking blocks, if necessary.

When fitting gear reducer and machine and/or gear reducer and eventual flange **B5** it is recommended to use **locking adhesives** such as LOCTITE on the fastening screws (also on flange mating surfaces).

For outdoor installation or in a hostile environment protect the gear motor with anticorrosion paint. Added protection may be afforded by water-repellent grease (especially around the rotary seating of seal rings and the accessible zones of shaft end).

Gearmotors should be protected wherever possible, and by whatever appropriate means, from solar radiation and extremes of weather; weather protection **becomes essential** for **B6, V5** and **V6** mounting positions.

For ambient temperatures greater than 40 °C or less than 0 °C, consult us.

Before wiring up the gearmotor, make sure that motor voltage corresponds to input voltage. If the direction of rotation is not as desired, invert two phases at the terminals.

If overloads are imposed for long periods of time, or if shocks or danger of jamming are envisaged, then motor-protections, electronic torque limiters, safety couplings, control units or other suitable devices should be fitted.

Where duty cycles involve a high number of starts on load, it is advisable to utilize **thermal probes** (fitted on the wiring) for motor protection; a thermal overload relay is unsuitable since its threshold must be set higher than the motor's nominal current rating.

Use varistors to limit voltage peaks due to contactors.

Warning! Bearing life, good shaft and coupling running depend on alignment precision between the shafts. Carefully align the gearmotor with the driven machine (with the aid of shims if need be), interposing flexible couplings whenever possible.

Whenever a leakage of lubricant could cause heavy damages, increase the frequency of inspections and/or envisage appropriate control devices (e.g.: remote oil level gauge, lubricant for food industry, etc.).

In polluting surroundings, take suitable precautions against lubricant contamination through seal rings or other.

Gearmotor should not be put into service before it has been incorporated on a machine which is conform to 98/37/EC directive.

For brake or non-standard motors, consult us for specific documentation.

Gear reducer size	Hollow low speed shaft diameter		Shaft recommended tolerances	
	øu		Load cl. I	Load cl. II, III
118	0.75	+0.0010 +0	+0.0003 +0.0002	+0.0005 -0.0003
225	1	+0.0010 +0	+0.0004 +0	+0.0006 -0.0003
325	1.125	+0.0010 +0	+0.0004 +0	+0.0006 -0.0003
430	1.25	+0.0010 +0	+0.0004 +0	+0.0006 -0.0003
535	1.375	+0.0010 +0	+0.0004 +0.0002	+0.0007 -0.0001
742	1.625	+0.0010 +0	+0.0004 +0.0002	+0.0007 -0.0001

5 -Installation and maintenance

5.2 - Machine shaft

For the machine shaft, where the hollow shaft of the gear reducer is to be keyed, the following tolerances are recommended (according to load classification): For complete hollow low speed shaft dimensions see ch.

Important: the shoulder diameter of the machine shaft end abutting with the gear reducer must be at least $(1.18 + 1.25) \cdot U$.

Before mounting, clean mating surfaces thoroughly and lubricate against seizure and fretting corrosion. Installing and removal operations should be carried out with **pullers** and **jacking screws**.

Fitting of components to shaft ends

For the **bore** of **parts** keyed to the low speed shaft end, the following **tolerances** are **recommended** (according to load classification):

Gear reducer size	Low speed shaft diameter		Bore recommended tolerances	
	øU		Load cl. I	Load cl. II, III
118	0.75	+0 -0.0005	+0.0006 +0	+0.0008 -0.0005
225	1	+0 -0.0005	+0.0016 +0	+0.0010 -0.0006
325	1.125	+0 -0.0005	+0.0016 +0	+0.0010 -0.0006
430	1.25	+0 -0.0005	+0.0016 +0	+0.0010 -0.0006
535	1.375	+0 -0.0005	+0.0020 +0	+0.0013 -0.0007
742	1.625	+0 -0.0005	+0.0020 +0	+0.0013 -0.0007

5.3 - Shaft-mounting arrangements

IMPORTANT. When shaft mounted, the gearmotor must be supported both axially and radially by the shaft end of the driven machine, as well as anchored against rotation only, by means of a reaction having **freedom of axial movement** and sufficient **clearance in its couplings** to permit minor oscillations – always in evidence – without provoking dangerous overloads on the actual gearmotor. Pivots and components subject to sliding have to be properly lubricated; we recommend the use of a locking adhesive such as LOCTITE 601 when fitting the bolts.

5.4 - IEC frame motor mounting or replacement

For IEC frame motor mounting simply observe the following instructions:

- ensure that the mating surfaces are machined under standard rating (IEC 72.1; UNEL 13501-69; DIN 42955) at least;
- clean surfaces to be fitted, thoroughly;
- check and, if necessary, lower the parallel key so as to leave a clearance of 0.004 - 0.008 in (01 - 0.2 mm) between its tip and the bottom of the keyway; if shaft keyway is without end, lock the key with a pin;
- lubricate surfaces to be fitted against fretting corrosion.

For other details regarding motor mounting, see specific information and/or consult us.

The replacement of a motor supplied by us with an IEC frame motor 1) of the same power supplied by the Customer is possible only for motors stated in ch. 9, in mounting positions B5 or B14.

However, if need be and accepting a reduced machine duty cycle, it is possible to replace the motors in mounting position B5*, B14* (i.e.: with power of motor power-to-size correspondence not according to standard), B5R and B14R with motors standardized to IEC of smaller power and size, if possible, having mating dimensions as stated in ch. ...

1) NEMA C-Face motors may be fitted in combination with an adapter device supplied as accessory (see ch. 13 for dimensions and possible combination).

6 -Technical formulae

Main formulas concerning mechanical drives, according to the Technical System and International Unit System (SI).

Size	With Technical System units	With SI units
starting or stopping time as a function of an acceleration or deceleration, of a starting or braking torque	$t = \frac{v}{a} \text{ [s]}$ $t = \frac{Gd^2 \cdot n}{375 \cdot M} \text{ [s]}$	$t = \frac{J \cdot \omega}{M} \text{ [s]}$
velocity in rotary motion	$v = \frac{\pi \cdot d \cdot n}{60} = \frac{d \cdot n}{19,1} \text{ [m/s]}$	$v = \omega \cdot r \text{ [m/s]}$
speed	$n = \frac{60 \cdot v}{\pi \cdot d} = \frac{19,1 \cdot v}{d} \text{ [min}^{-1}\text{]}$	$\omega = \frac{v}{r} \text{ [rad/s]}$
acceleration or deceleration as a function of starting or stopping time	$a = \frac{v}{t} \text{ [m/s}^2\text{]}$	
angular acceleration or deceleration as a function of a starting or stopping time, of a starting or braking torque	$\alpha = \frac{n}{9,55 \cdot t} \text{ [rad/s}^2\text{]}$	$\alpha = \frac{\omega}{t} \text{ [rad/s}^2\text{]}$
	$\alpha = \frac{39,2 \cdot M}{Gd^2} \text{ [rad/s}^2\text{]}$	$\alpha = \frac{M}{J} \text{ [rad/s}^2\text{]}$
starting or stopping distance as a function of a starting or stopping time, of a starting or braking velocity	$s = \frac{a \cdot t^2}{2} \text{ [m]}$	$s = \frac{v \cdot t}{2} \text{ [m]}$
starting or stopping angle as a function of an angular acceleration or deceleration, of a final or initial angular velocity	$\varphi = \frac{n \cdot t}{19,1} \text{ [rad]}$	$\varphi = \frac{\omega \cdot t}{2} \text{ [rad]}$
mass	$m = \frac{G}{g} \text{ [}\frac{\text{kgf s}^2}{\text{m}}\text{]}$ m is the unit of mass [kg]	
weight (weight force)	G is the unit of weight (weight force) [kgf]	$G = m \cdot g \text{ [N]}$
force in vertical (lifting), horizontal, inclined motion of translation (μ = coefficient of friction; φ = angle of inclination)	$F = G \text{ [kgf]}$	$F = m \cdot g \text{ [N]}$
	$F = \mu \cdot G \text{ [kgf]}$ $F = G (\mu \cdot \cos \varphi + \text{sen } \varphi) \text{ [kgf]}$	$F = \mu \cdot m \cdot g \text{ [N]}$ $F = m \cdot g (\mu \cdot \cos \varphi + \text{sen } \varphi) \text{ [N]}$
dynamic moment Gd^2 , moment of inertia J due to a motion of translation (numerically $J = \frac{Gd^2}{4}$)	$Gd^2 = \frac{365 \cdot G \cdot v^2}{n^2} \text{ [kgf m}^2\text{]}$	$J = \frac{m \cdot v^2}{\omega^2} \text{ [kg m}^2\text{]}$
torque as a function of a force, of a dynamic moment or of a moment of inertia, of a power	$M = \frac{F \cdot d}{2} \text{ [kgf m]}$	$M = F \cdot r \text{ [N m]}$
	$M = \frac{Gd^2 \cdot n}{375 \cdot t} \text{ [kgf m]}$	$M = \frac{J \cdot \omega}{t} \text{ [N m]}$
	$M = \frac{716 \cdot P}{n} \text{ [kgf m]}$	$M = \frac{P}{\omega} \text{ [N m]}$
work, energy in motion of translation, in rotary motion	$W = \frac{G \cdot v^2}{19,6} \text{ [kgf m]}$	$W = \frac{m \cdot v^2}{2} \text{ [J]}$
	$W = \frac{Gd^2 \cdot n^2}{7160} \text{ [kgf m]}$	$W = \frac{J \cdot \omega^2}{2} \text{ [J]}$
power in motion of translation, in rotary motion	$P = \frac{F \cdot v}{75} \text{ [CV]}$	$P = F \cdot v \text{ [W]}$
	$P = \frac{M \cdot n}{716} \text{ [CV]}$	$P = M \cdot \omega \text{ [W]}$
power available at the shaft of a single-phase motor ($\cos \varphi$ = power factor)	$P = \frac{U \cdot I \cdot \eta \cdot \cos \varphi}{736} \text{ [CV]}$	$P = U \cdot I \cdot \eta \cdot \cos \varphi \text{ [W]}$
power available at the shaft of a three-phase motor	$P = \frac{U \cdot I \cdot \eta \cdot \cos \varphi}{425} \text{ [CV]}$	$P = 1,73 \cdot U \cdot I \cdot \eta \cdot \cos \varphi \text{ [W]}$

Note. Acceleration or deceleration are understood constant; motion of translation and rotary motion are understood rectilinear and circular respectively.



Rossi

Solutions for
an evolving
industry

HEADQUARTERS

Rossi S.p.A.

Via Emilia Ovest 915/A
41123 Modena - Italy

Phone +39 059 33 02 88

info@rossi.com
www.rossi.com

Rossi North America

3355 Martin Farm Road Suite 400
Suwanee, GA 30024-7124

Phone +1 800 931 2044 - Fax 678-288-3658

info@rossi.com/northamerica
www.rossi.com/northamerica

© Rossi S.p.A. Rossi reserves the right to make any modification whenever to this publication contents. The information given in this document only contains general descriptions and/or performance features which may not always specifically reflect those described.

The Customer is responsible for the correct selection and application of product in view of its industrial and/or commercial needs, unless the use has been recommended by technical qualified personnel of Rossi, who were duly informed about Customer's application purposes. In this case all the necessary data required for the selection shall be communicated exactly and in writing by the Customer, stated in the order and confirmed by Rossi. The Customer is always responsible for the safety of product applications. Every care has been taken in the drawing up of the catalog to ensure the accuracy of the information contained in this publication, however Rossi can accept no responsibility for any errors, omissions or outdated data. Due to the constant evolution of the state of the art, Rossi reserves the right to make any modification whenever to this publication contents. The responsibility for the product selection is of the Customer, excluding different agreements duly legalized in writing and undersigned by the Parties.

2620.CRPCAT.AS.us-en.COR.01.01