

E series



Coaxial gear reducers and gearmotors



Contents

1	Rossi for You	4
2	Features, benefits and range	8
3	Product Overview	22
4	Installation and maintenance	84
5	Accessories and non-standard designs	90
6	Technical formulae	98

1

Rossi for You



Innovation

Rossi offers a wide range of **solutions for an evolving industry**, flexible and innovative gearboxes and gearmotors for customer tailored solutions to maximize performance and minimize the total cost of ownership.



High quality, 3 years warranty

Our drive is to innovate and boost operations by manufacturing performing, precise, reliable and high-quality products all over the world. We are always one step forward in offering and developing solutions that can satisfy an unlimited number of application needs, even in the most demanding conditions.



Reliability

We are a reliable company with the right flexibility and know-how to respond to worldwide market requests, in all application fields, without leaving aside our commitment for the environment and value on human safety, to protect everyone's future.



Tools and processes

We continue to invest in new tools and processes, so our highly skilled specialist team in different fields are supporting you to find the best solution suitable for your demands, always by your side on every step of the project.



After-sale service

Highly trained mechanics and support teams can ensure a fast and efficient after-sale service providing support worldwide.



Digital support

Alongside our 24/7 **Rossi for You** support portal you have a suite of digital support tools enabling real time access to your order tracking, invoices, spare part tables download and contact to our service.

70
YEARS

Experience

Shaped by more than 70 years of history Rossi meets your unique needs whether you need a standard design or a customized solution.



Global presence local service



Local support

Sales, customer service,
technical support, spare parts



15 branches*



Worldwide distribution network*

A widespread sales network of subsidiaries and dealers in nearly all industrialized countries. By your side from the design to after-sale phase, Rossi is a flexible and dependable partner throughout the world.

Rossi for You, our customer web portal, provides a 24/7 global coordination of the ordering, supply and service processes.



United States

Suwanee, GA



Brazil

Cordeiropolis, SP



*All contacts available on www.rossi.com



Headquarters



Branches



Assembly plants

United Kingdom

Coventry



Netherlands

Panningen



Germany

Dreieich



Poland

Wroclaw



Turkey

Izmir



China

Shanghai



Suzhou



Taiwan

Kaohsiung City



Spain

Barcelona



France

Saint Priest



Italy

Modena



Ganaceto



Lecce



India

Coimbatore



Australia

Perth



Malaysia

Kuala Lumpur



South Africa

La Mercy



Features, benefits and range





Maximum performance

We drive the heaviest applications worldwide



Sustainability

We care about environment



Modular system

For cost-effective and high quality solutions



Innovation

We are constantly thinking forward, solutions for an evolving industry



Digitalization

Rossi for You is always at your disposal for any info



Know-how

We support you through interdisciplinary know-how

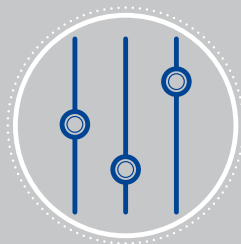

Customization

Cost-effective solutions starting from standard products

Coaxial gear reducers and gearmotors



2I, 3I 32 ... 41*
with 2, 3 cylindrical
gear pairs



2I, 3I 50 ... 180
with 2, 3 cylindrical
gear pairs

Combined gear reducer and gearmotor units



MR 3I + R 2I, 3I



MR 3I + MR 2I, 3I

* gearmotors only

Symbols and units of measure

Symbols used in the catalogue and formulae, in alphabetical order, with relevant units of measure.

Symbol	Definition	Units of measure			Notes
		In catalog	In the formulae		
			Technical System	SI ¹⁾ System	
	dimensions	mm	-		
<i>a</i>	acceleration	-	m/s ²		
<i>d</i>	diameter	-	m		
<i>f</i>	frequency	Hz	Hz		
<i>f_s</i>	service factor				
<i>f_t</i>	thermal factor				
<i>F</i>	force	-	kgf	N ²⁾	1 kgf ≈ 9,81 N ≈ 0,981 daN
<i>F_r</i>	radial load	daN	-		
<i>F_a</i>	axial loads	daN	-		
<i>g</i>	acceleration of gravity	-	m/s ²		normal value 9,81 m/s ²
<i>G</i>	weight (weight force)	-	kgf	N	
<i>Gd²</i>	dynamic moment	-	kgf m ²	-	
<i>i</i>	transmission ratio				$i = \frac{n_1}{n_2}$
<i>I</i>	electric current	-	A		
<i>J</i>	moment of inertia	kg m ²	-	kg m ²	
<i>L_h</i>	bearing life	h	-		
<i>m</i>	mass	kg	kgf s ² /m	kg ³⁾	
<i>M</i>	torque	daN m	kgf m	N m	1 kgf m ≈ 9,81 N m ≈ 0,981 daN m
<i>n</i>	speed	min ⁻¹	giri/min rev/min	-	1 min ⁻¹ ≈ 0,105 rad/s
<i>P</i>	power	kW	CV	W	1 CV ≈ 736 W ≈ 0,736 kW
<i>P_t</i>	thermal power	kW	-		
<i>r</i>	radius	-	m		
<i>R</i>	variation ratio				$R = \frac{n_{2,max}}{n_{2,min}}$
<i>s</i>	distance	-	m		
<i>t</i>	Celsius temperature	°C	-		
<i>t</i>	time	s min h d	s		1 min = 60 s 1 h = 60 min = 3 600 s 1 d = 24 h = 86 400 s
<i>U</i>	voltage	V	V		
<i>v</i>	velocity	-	m/s		
<i>W</i>	work, energy	MJ	kgf m	J ⁴⁾	
<i>z</i>	frequency of starting	starts/h	-		
<i>α</i>	angular acceleration	-	rad/s ²		
<i>η</i>	efficiency				
<i>η_s</i>	static efficiency				
<i>μ</i>	friction coefficient				
<i>φ</i>	plane angle	°	rad		1 rev = 2 π rad $1^\circ = \frac{\pi}{180}$ rad
<i>ω</i>	angular velocity	-	-	rad/s	1 rad/s ≈ 9,55 min ⁻¹

Additional indexes and other signs

Ind.	Definition
max	maximum
min	minimum
N	nominal
1	relating to high speed shaft (input)
2	relating to low speed shaft (output)
+	from ... to
≈	approximately equal to
≥	greater than or equal to
≤	less than or equal to

1) SI are the initials of the International Unit System, defined and approved by the General Conference on Weights and Measures as the only system of units of measure.
Ref. CNR UNI 10 003-84 (DIN 1 301-93 NF X 02.004, BS 5 555-93, ISO 1 000-92).
UNI: Ente Nazionale Italiano di Unificazione.
DIN: Deutscher Normenausschuss (DNA).
NF: Association Française de Normalisation (AFNOR).
BS: British Standards Institution (BSI).
ISO: International Organization for Standardization.

2) Newton [N] is the force imparting an acceleration of 1 m/s² to a mass of 1 kg.

3) Kilogramme [kg] is the mass of the prototype kept at Sèvres (i.e. 1 dm³ of distilled water at 4 °C).

4) Joule [J] is the work done when the point of application of a force of 1 N is displaced through a distance of 1 m.

Universal mounting (patented; lower feet, upper feet, B5 flange with low speed shaft end shifted forward) excluding sizes 32 ... 41.

Closer intermediate size steps (for size pairs, standard and strengthened, only one housing and many components in common, changing only the ones allowing higher performances of greater size; improved modular construction) **offering sizes closer to every application need and maintaining nearly the same component number for maximum economy of solution; same mounting dimensions for the size pairs**

Rigid and precise single-piece cast iron housing (excluding sizes 32 ... 41)

Generously proportioned bearings of low speed shaft (bearings and shaft) **in order to withstand high loads** on shaft end

Possibility of mounting large size motors

Manufacturing and product management flexibility

High manufacturing quality standard

Minimum maintenance requirements

Standard motor to IEC

High, reliable and tested performances

Pinion of final reduction with three bearings (excluding sizes 32 ... 41) **in order to ensure best meshing conditions** (no overhang wheel; maximum rigidity and overloading capacity, maximum reduction of noise level)

This range of gear reducers and gearmotors combines and exalts the traditional qualities of coaxial gear reducers – **compactness, economy** –, with the ones deriving from modern design, manufacturing and operating criteria – **strength and suitability also for heaviest applications, universality and ease of application, wide range of sizes, service** – the advantages typically associated with high quality gear reducers produced in large series.

Foot mounting

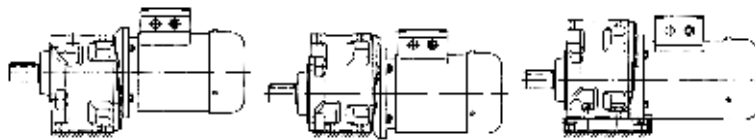

«Standard» shaft height (H)

«Low» shaft height (H₀), minimum overall dimensions

Adaptor for interchangeability

Flange mounting

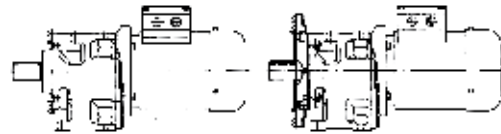

Standard flange (through holes) and low speed shaft end shifted forward for minimum overhang

Oversized flange (through holes) and low speed shaft end having shoulder coinciding with flange plane

a - Gear reducer

Structural features

Main specifications are:

- **universal mounting (patented)** with lower and upper feet and B5 flange **integral** with housing (excluding sizes 32 ... 41 whose mounting is either with feet or with flange always integral with housing);
- **low speed shaft end** shifted forward (excluding size 40) compared to flange plane, for **smaller overhang** having same position of external radial load;
- modern conception according to Rossi **new modular system** (improved modular construction both for component parts and assembled product); to withstand **high loads on high and low speed shaft ends**;

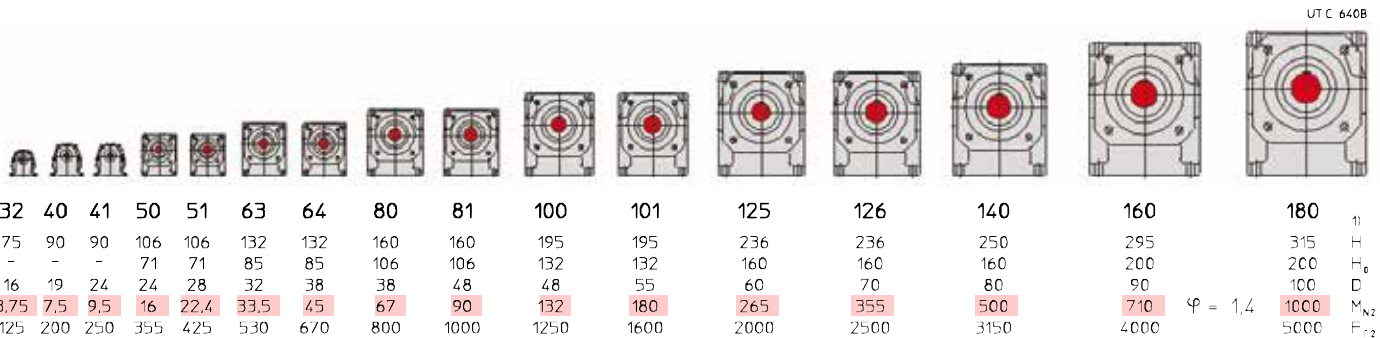

1) H, H₀ shaft height
 D Ø low speed shaft end
 M_{N2} nominal torque [daN m]
 F_{r2} radial load [daN]

- maximum compactness and reduced overall dimensions – and equal for 2l and 3l – especially in longitudinal direction; coaxial low and high speed shafts excluding sizes 140 ... 180 for which they are slightly misaligned (see ch. 3.2 and 3.8);
- **single-piece** cast iron **housing** 200 UNI ISO 185 (excluding sizes 32 ... 41) with **stiffening ribs** and high lubricant capacity;
- gear reducer overall sized so as to accept particularly powerful motors, to permit the transmission of **high** nominal and maximum **torques** and support **high loads on low and high speed shaft ends**;
- cylindrical roller or ball bearings on intermediate shafts duly sized for every condition;
- bearings of **low speed shaft** generously proportioned in order to withstand high loads on low speed shaft end (which is also proportioned for the same purpose);

Cuscinetto Bearing	Grandezza - Size															
	32	40	41	50	51	63	64	80	81	100	101	125	126	140	160	180
lato esterno external side	6203	6204	6205	6206	6206	6207	6208	6308	NJ210EC	6310	NJ212EC	30214	32016	32018	32021	32024
lato interno internal side	6201	6004	6203	6204	6204E	6205E	6206E	6306	NJ207EC	6308	NJ210EC	30212	32014	32016	32018	32021

- pinion of final reduction with **three bearings** (excluding sizes 32 ... 41) in order to ensure best meshing conditions (no overhang wheel, maximum rigidity and **overloading capacity**, maximum **reduction of noise level**);
- gear reducers: input face having machined flange and holes (excluding sizes 32 and 40);
- gearmotors: **standard motor to IEC** with pinion directly mounted onto shaft end;
- shaft end with parallel key and tapped butt-end hole;
- standard dimensions and compliance with standards;
- grease or oil-bath lubrication; with synthetic grease for sizes 32 ... 41 or synthetic oil sizes 50 ... 81 all supplied **filled with lubricant** for lubrication **«for life»** and with a plug (sizes 32 ... 64) or two plugs (sizes 80 and 81); with synthetic or mineral oil (ch. 4) with filler plug with **valve**, drain and level plug (sizes 100 ... 180); sealed;
- **paint external** coating in epoxy powder paint (sizes 32 ... 41) or water based dual compound acrylic-polyurethane resin basis enamel (sizes 50 ... 180) resistant to atmospheric and aggressive agents (corrosivity category C3 ISO 12944-2); suitable for further coats only with dual-compound products after degreasing and sanding; color blue RAL 5010 DIN 1843, other colors and/or painting cycles on request); **internal** protection with epoxy powder paint (sizes 32 ... 41) suitable to resist synthetic oils or with synthetic paint (sizes 50 ... 180) suitable to resist polyalphaolefines based synthetic or mineral oils.
- possibility of obtaining combined gear reducer and gearmotor units providing high transmission ratios;
- non-standard designs: see ch. 5.

Train of gears:

- 2, 3 cylindrical gear pairs (5, 6 in combined units);
- 7 sizes with final reduction centre distance to R 10 series (32 ... 125, with 6 size pairs: standard and strengthened); 3 sizes with final reduction centre distance to R 20 series (140 ... 180) for a total of **16 sizes**;
- nominal transmission ratios to R 10 series (6,3 ... 6 300) for gear reducers;
- output speeds close to standard number R 20 series (0,45 ... 710 min⁻¹) for gearmotors;
- casehardened and hardened gear pairs in 16 CrNi4 or 20 MnCr5 steel depending on size and 18 NiCrMo5 steel, according to UNI 7846-78;
- helical toothed gear pairs with **ground** profile;
- gears load capacity calculated for tooth breakage and pitting.

Specific standards:

- nominal transmission ratios and main dimensions according to UNI 2016 standard numbers (DIN 323-74, NF X 01.001, BS 2045-65, ISO 3-73);
- tooth profiles to UNI 6587-69 (DIN 867-86, NF E 23.011, BS 436.2-70, ISO 53-74);
- shaft heights to UNI 2946-68 (DIN 747-76, NF E 01.051, BS 5186-75, ISO 496-73);
- fixing flanges B14 and B5 taken from UNEL 13501-69 (DIN 42948-65, IEC 72.2);
- medium series fixing holes to UNI 1728-83 (DIN 69-71, NF E 27.040, BS 4186-67, ISO/R 273);
- cylindrical shaft ends (long or short) to UNI ISO 775-88 (DIN 748, NF E 22.05.051, BS 4506-70, ISO/R775) with tapped butt-end hole to UNI 9321 (DIN 332 Bl. 2-70, NF E 22.056) excluding d-D diameter ratio;
- parallel keys to UNI 6604-69 (DIN 6885 Bl. 1-68, NF E 27.656 and 22.175, BS 4235.1-72, ISO/R/773-69) except for specific cases of motor-to-gear reducer coupling where key height is reduced;
- mounting positions taken from CEI 2-14 (DIN EN 60034-7, IEC 34.7);
- load capacity verified according to UNI 8862, DIN 3990, AFNOR E 23-015, ISO 6336 for running time \geq **12 500 h**.

Sound levels L_{WA} and \bar{L}_{pA} [dB(A)]

Standard production sound power level L_{WA} [dB(A)]¹⁾ and mean sound pressure level \bar{L}_{pA} [dB(A)]²⁾ for gearmotors assuming nominal load, and input speed $n_1 = 1\ 400^{3)}\ \text{min}^{-1}$. Tolerance +3 dB(A).

If required, gear reducers can be supplied with reduced sound levels (normally 3 dB(A) below tabulated values); consult us.

Values in table are valid also for gear reducers.

In case of gearmotor with 4 poles 60 Hz motor (motor supplied by Rossi) add 1 dB(A) to the values in table.

Size and train of gears	Gearmotors with 4 poles motor																				
	63		71		80		90		100 112		132		160 180 M		180 L 200		225 250		280		
	L_{WA}	\bar{L}_{pA}	L_{WA}	\bar{L}_{pA}	L_{WA}	\bar{L}_{pA}	L_{WA}	\bar{L}_{pA}	L_{WA}	\bar{L}_{pA}	L_{WA}	\bar{L}_{pA}	L_{WA}	\bar{L}_{pA}	L_{WA}	\bar{L}_{pA}	L_{WA}	\bar{L}_{pA}	L_{WA}	\bar{L}_{pA}	
32, 40, 41	2I	63	54	65	56	68	59	—	—	—	—	—	—	—	—	—	—	—	—	—	—
	3I	62	53	64	55	—	—	—	—	—	—	—	—	—	—	—	—	—	—	—	—
50, 51	2I	—	—	66	57	69	60	71	62	—	—	—	—	—	—	—	—	—	—	—	—
	3I	62	53	65	56	68	59	—	—	—	—	—	—	—	—	—	—	—	—	—	—
63, 64	2I	—	—	—	—	69	60	73	64	75	66	—	—	—	—	—	—	—	—	—	—
	3I	—	—	66	57	68	59	71	62	—	—	—	—	—	—	—	—	—	—	—	—
80, 81	2I	—	—	—	—	—	—	73	64	77	68	78	69	—	—	—	—	—	—	—	—
	3I	—	—	69	60	72	63	75	66	—	—	—	—	—	—	—	—	—	—	—	—
100, 101	2I	—	—	—	—	—	—	77	68	77	68	80	71	81	72	—	—	—	—	—	—
	3I	—	—	—	—	73	64	76	67	78	69	—	—	—	—	—	—	—	—	—	—
125, 126, 140	2I	—	—	—	—	—	—	—	—	81	72	83	74	85	76	87	78	—	—	—	—
	3I	—	—	—	—	—	—	77	68	80	71	81	72	—	—	—	—	—	—	—	—
160, 180	2I	—	—	—	—	—	—	—	—	—	—	83	74	86	77	88	79	90	81	—	—
	3I	—	—	—	—	—	—	—	—	81	72	82	73	84	75	86	77	—	—	—	—

1) To ISO/CD 8579.

2) Mean value of measurement at 1 m from external profile of gear reducer standing in free field on a reflecting surface.

3) For n_1 , $710 \div 1\ 800\ \text{min}^{-1}$, modify tabulated values thus: $n_1 = 710\ \text{min}^{-1}$, -3 dB(A); $n_1 = 900\ \text{min}^{-1}$, -2 dB(A); $n_1 = 1\ 120\ \text{min}^{-1}$, -1 dB(A); $n_1 = 1\ 800\ \text{min}^{-1}$, +2 dB(A).

b - Electric motor

Gearmotor dimensions and masses of present catalog (see ch. 3.6 and 3.8) refer to HB and HBZ motors (cat. TX).

Main structural features (HB motor and HBZ brake motor)

- motor **standardized to IEC**;
- asynchronous three-phase, totally-enclosed, externally ventilated, with cage rotor;
- single polarity, frequency 50 Hz, voltage Δ 230 V Y 400 V (size ≤ 132), Δ 400 V (size ≥ 160);
- **IP 55** protection, **insulation** class **F**, temperature rise class **B**;
- rated power delivered on continuous duty S1 (excluding some cases of motor sizes with power not according to standard; see specific documentation) and referred to nominal voltage and frequency; maximum ambient temperature 40 °C and altitude 1 000 m;
- capacity to withstand one or more overloads up to 1,6 times the nominal load for a maximum total period of 2 min per single hour;
- starting torque with direct on-line start at least 1,6 times the nominal one (it is usually higher);
- mounting position B5 and derivatives as shown in the following table;
- **suitable for inverter duty** (generous electromagnetic sizing, low-loss electrical stamping, phase separators, etc.)
- designs available for every application need: flywheel, independent cooling fan, independent cooling fan and encoder, etc.

Constructive features of HBZ brake motor

- particularly strong construction to withstand braking stresses; **maximum reduction of noise level**;
- spring-loaded d.c. electromagnetic brake; feeding from the terminal box; brake can also be independently fed directly from the line;
- braking torque **proportioned** to motor torque (usually $M_f \approx 2 M_N$) and adjustable by adding or removing spring pairs;
- possibility of high frequency of starting;
- quick and rapid stop;
- hand lever for manual release with automatic return (on request for size $\leq 160S$); removable lever rod.

For other specifications and details see **specific documentation of cat. TX**

Main coupling dimensions

Grand. motore Motor size	 IEC 60072 (UNEL 13117-17, DIN 43677 Bl. 1.A-65) Forma costruttiva motore - Motor mounting position														
	IM B5				B5R				B5A						
	Ød	x	e	-	ØP	Ød	x	e	-	ØP	Ød	x	e	-	ØP
63	11	x	23	-	140	-	-	-	-	14	x	30	-	140	
71	14	x	30	-	160	11	x	23	-	140	14	x	30	-	140
80	19	x	40	-	200	14	x	30	-	160	19	x	40	-	160
90	24	x	50	-	200	19	x	40	-	200	-	-	-	-	-
100, 112	28	x	60	-	250	24	x	50	-	200	-	-	-	-	-
132	38	x	80	-	300	28	x	60	-	250	-	-	-	-	-
160	42	x	110	-	350	38	x	80	-	300	-	-	-	-	-
180	48	x	110	-	350	-	-	-	-	-	-	-	-	-	-
200	55	x	110	-	400	48	x	110	-	350	-	-	-	-	-
225	60	x	140	-	450	-	-	-	-	-	-	-	-	-	-
250	65	x	140	-	550	60	x	140	-	450	-	-	-	-	-
280	75	x	140	-	550	-	-	-	-	-	-	-	-	-	-

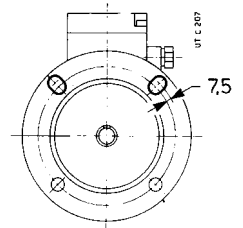

ATTENTION: Electric motor flange of gearmotors MR 3l 50, 51 with motor size 63 must have the two top holes slotted outwards as shown in the drawing.

Short time duty (S2) and intermittent periodic duty (S3); duty cycles S4 ... S10

In case of a duty-requirement type S2 ... S10 the motor power can be increased as per the following table; starting torque keeps unchanged.

Short time duty (S2). — Running at constant load for a given period of time less than that necessary to reach normal running temperature, followed by a rest period long enough for motor's return to ambient temperature.

Intermittent periodic duty (S3). — Succession of identical work cycles consisting of a period of running at constant load and a rest period. Current peaks on starting are not to be of an order that will influence motor heat to any significant extent.

$$\text{Cyclic duration factor} = \frac{N}{N+R} \cdot 100\%$$

where: N being running time at constant load,
 R the rest period and $N + R = 10$ min (if longer consult us)

Servizio - Duty		Grandezza motore ¹⁾ - Motor size ¹⁾		
		63 ... 90	100 ... 132	160 ... 280
S2	durata del servizio duration of running	90 min 1	1	1,06
		60 min 1	1,06	1,12
		30 min 1,12	1,18	1,25
		10 min 1,25	1,25	1,32
S3	rapporto di intermittenza cyclic duration factor	60% 40%	1,12 1,18	1,25 1,32
		25%	1,25	
		15%	1,32	
S4 ... S10		interpellarci - consult us		

1) For motor sizes 90LC 4, 112MC 4, 132MC 4, consult us.

Frequency 60 Hz

Normal motors up to size 132 wound for 50 Hz can be fed at 60 Hz; in this case speed increases by 20%. If input-voltage corresponds to winding voltage, power keeps unchanged, providing that higher temperature rise values are acceptable, starting is not on full load and that the power requirement is not unduly demanding, whilst starting and maximum torques decrease by 17%. If input-voltage is 20% higher than winding voltage, power increases by 20% whilst starting and maximum torques keep unchanged.

For **brake** motors see **specific literature**.

From size 160 upwards motors — both standard and brake ones — should be wound for 60 Hz exploiting the 20% power increase as a matter of course.

Power available with high ambient temperature or high altitude

When motor has to run at an ambient temperature higher than 40 °C or at altitude above sea level higher than 1 000 m, it has to be derated according to the following tables:

Temperatura ambiente [°C] Ambient temperature [°C]	30	40	45	50	55	60	
P/P_N [%]	106	100	96,5	93	90	86,5	
Altitudine s.l.m. [m] Altitude l.a.s. [m]	1 000	1 500	2 000	2 500	3 000	3 500	4 000
P/P_N [%]	100	96	92	88	84	80	76

Specific standards:

- nominal powers and dimensions to CENELEC HD 231 (IEC 72-1, DIN 42677, NF C51-120, BS 5000-10 and BS 4999-141) for mounting positions IM B5, IM B14 and derivatives;
- nominal performances and running specifications to CENELEC EN 60034-1 (IEC 34-1, CEI EN 60034-1, DIN VDE 0530-1, NF C51-111, BS 4999-101);
- protection to CENELEC EN 60034-5 (IEC 34-5, CEI 2-16, DIN EN 60034-5, NF C51-115, BS 4999-105);
- mounting positions to CENELEC EN 60034-7 (IEC 34-7, CEI EN 60034-7, DIN IEC 34-7, NF C51-117, BS EN 60034-7);
- sound levels to CENELEC 60034-9 (IEC 34.9, DIN 57530 pt. 9);
- balancing and vibration velocity (vibration under standard rating N) to CENELEC HD 53.14 S1 (IEC 34-14, ISO 2373 CEI 2-23, BS 4999-142); motors are balanced with half key inserted into shaft extension;
- cooling to CENELEC EN 60034-6 (CEI 2-7, IEC 34-6): standard type IC 411; type IC 416 for non-standard design with axial independent cooling fan.

blank page

Asynchronous three-phase motors, brake motors



HE - HB
Asynchronous three-phase motor



HEZ - HBZ
Asynchronous three-phase **brake motor**
with **d.c. brake**



HBF
Asynchronous three-phase **brake motor**
with **a.c. brake**



HBV
Asynchronous three-phase **brake motor**
with **d.c. safety brake**

Advanced design motors sharing the **same stator windings**, the same **rotors**, the same **housings**, the same **flanges**, the same performance, and the majority of technical solutions with its twin brake motor series (**HEZ, HBZ, HBF, and HBV**).

The generous electromagnetic sizing allow to achieve **high efficiency values** complying **with different energy saving regulations**:

- Efficiency class **IE3 (ErP)** for HB and HE;
- Efficiency class **IE3 (ErP)** for HEZ and HBZ

The electric design (terminal block, name plate, etc.) has been studied to comply, as standard, also with **NEMA MG1-12** for the maximum application flexibility and facility.

The strength and the precision of mechanical construction, the generous bearings and the wide range of non-standard designs available on catalog make this motor particularly suitable for coupling with gearmotors.

Thanks to its outstanding **low noise**, **progressivity** and **dynamic** characteristics, it is specifically suitable for **coupling with gearmotor minimizing the dynamic overloads** deriving from **starting and braking phases** (especially in case of motion reversals) and maintaining a **very good braking torque value**.

The excellent **operation progressivity** - when starting and braking - is assured by the brake anchor which is less quick in the impact (compared to a.c. HBF) and by the slight quickness of d.c. brakes.

Offering a comprehensive **range of accessories and non-standard designs** in order to satisfy all possible gearmotor application fields.

The **high reactivity** typical of **a.c. brake** and the **high braking capacity** make this brake motor **particularly suitable for heavy duties** requiring **quick brakings** and a **high number of operations** (e.g.: lifts with high frequency of starting, usually for size > 132, and/or for jog operations).

Vice versa, its very **high dynamic characteristics** (rapidity and frequency of starting) **are not advisable for the use in gearmotor coupling**, especially when these features are not strictly necessary for the application (avoiding useless overloads on the whole transmission).

Comprehensive **range of accessories and non-standard designs** in order to satisfy all application needs of gearmotors (in particular for HBF: IP 56, IP 65, encoder, independent cooling fan, independent cooling fan and encoder, double extension shaft, etc.).

Featuring **maximum economy**, **very reduced overall dimensions and moderate braking torque**, it is suitable for the coupling with gearmotor and can be applied as brake for **safety or parking stops** (e.g. cutting machines) and for operations at deceleration ramp end **during the running with inverter**.

The standard cast iron fan supplies a flywheel effect increasing the very good progressivity of starting and braking (typical of d.c. brake) being particularly **suitable for «light»¹⁾ traverse movements**.

1) Mechanism group M4 (max 180 starts/h) and on-load running L1 (light) or L2 (moderate) to ISO 4301/1, F.E.M./II 1997.

Product overview





Section content

3.1	Designation	22
3.2	Thermal power	24
3.3	Service factor	25
3.4	Selection	26
3.5	Nominal powers and torques	30
3.6	Designs, dimensions, mounting positions and oil quantities	38
3.7	Gearmotors selection tables	40
3.8	Designs, dimensions, mounting positions and oil quantities	62
3.9	Gear reducer and gearmotor combined units	64
3.10	Combined units dimensions	64
3.11	Radial loads on high speed shaft end	66
3.12	Radial and axial loads on low speed shaft end	66
3.13	Structural and operational details	78

Designation code

R **2I** **50** **U** **C** **2** **A** - **29,3** **B3**
MR **3I** **50** **U** **C** **2** **A** - **19 × 200** - **22,7** **V5** **HB3 80B4 230.400-50 B5** **TB3**

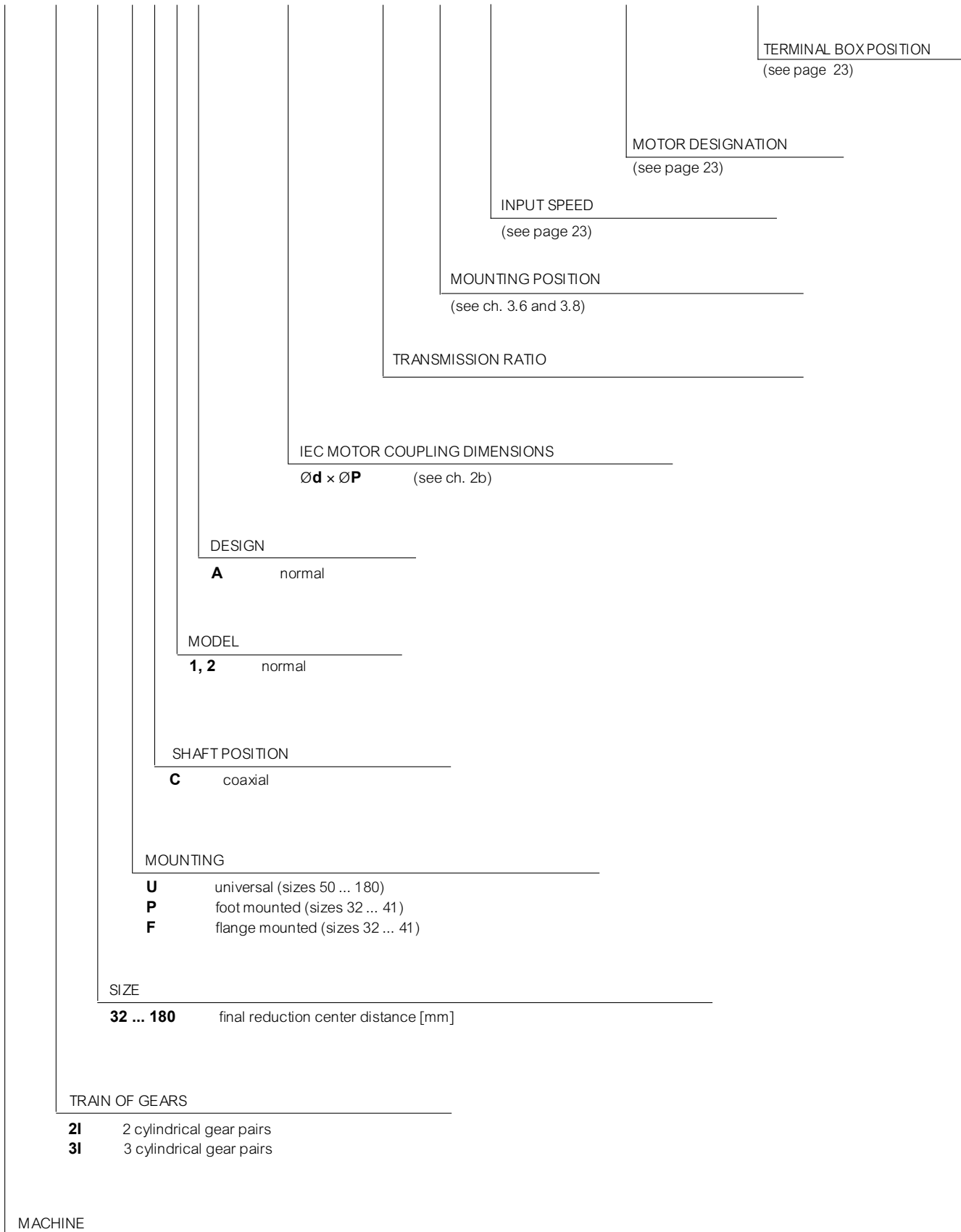

MACHINE

R gear reducer
MR gearmotor

Gear reducer mounting position

Gear reducer and gearmotor mounting positions are described in ch. 3.6, 3.8 (the mounting position designation refers to foot mounting only, even if gear reducers are for universal mounting, sizes 32 ... 41 excluded).

When having no particular needs, **prefer B3** (B3 or B5 for sizes 32 ... 41) **mounting position** for its technical and economic cost effectiveness (maximum simplification of lubrication system, lower oil splash, lower gear reducer heating, stock availability).

Input speed

Complete the designation stating the input speed n_1 , if $> 1400 \text{ min}^{-1}$:

Example:

R 2l 50 UC2A / 29,3 $n_1 = 2000 \text{ min}^{-1}$

Motor

When the gearmotor is supplied **equipped with a standard Rossi motor**, fill in the designation stating the motor designation (ref. cat. TX).

Example:

MR 3l 140 UC2A - 48 x 350 - 20,4

HB3 180M 4 400-50 B5

When **brake motor** is required, insert the letters **HBZ** (ref. cat. TX).

Example:

MR 3l 140 UC2A - 48 x 350 - 20,4

HB3Z 180M 4 400-50 B5

When the gearmotor is equipped **without motor**, omit the designation and add «without motor».

Esempio:

MR 3l 140 UC2A - 48x350 - 20,4

without motor

When motor is supplied by the **Buyer**¹⁾, complete the designation by stating the description of «motor supplied by us».

1) The motor, supplied by the Buyer must be to IEC with mating surfaces machined under accuracy rating IEC 60072-1 and is to be sent carriage and expenses paid to our factory for fitting to the gear reducer.

Example:

MR 3l 140 UC2A - 48x350 - 20,4

motore supplied by us

Motor terminal box position

Complete the designation stating the motor terminal box position if differing from the standard one (TB0; scheme below); the cable input is Buyer's responsibility.

Example:

MR 3l 140 UC2A - 48x350 / 20,4

HB3 180M 4 400-50 B5 **TB3**

View from drive end (D)

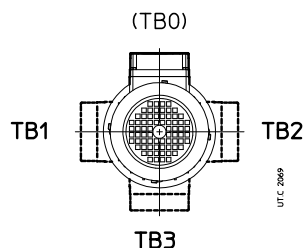
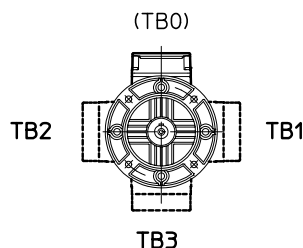

View from non-drive end (N)

Accessories and non-standard designs

In the event of a gear reducer or gearmotor being required in a design different from those stated above, specify it in detail (ch. 5).

Nominal thermal power P_{tN} , written in red in the following tables, is that which can be applied at the gear reducer input without exceeding 95 °C¹⁾ approximately oil temperature when operating in following running conditions:

- input speed $n_1 = 1\ 400\ \text{min}^{-1}$;
- mounting position B3;
- continuous duty S1;
- maximum ambient temperature 40 °C;
- maximum altitude 1 000 m above sea level;
- air speed $\geq 1,25\ \text{m/s}$ (typical value in presence of a gearmotor with self cooled motor).

For the cases marked at ch. 7 and 9 it should be always verified that the applied power P_i is less than or equal to gear reducer nominal thermal power P_{tN} multiplied by the corrective coefficients f_{t1} , f_{t2} , f_{t4} , f_{t5} (stated in the following tables) considering the several operational conditions:

$$P_i \leq P_{tN} \cdot f_{t1} \cdot f_{t2} \cdot f_{t4} \cdot f_{t5}$$

When this condition is not satisfied consider the use of special lubricant or a cooling unit with heat exchanger: consult us.

Thermal power needs not be taken into account when maximum duration of continuous running time is 1 ÷ 3 h (from small to large gear reducer sizes) followed by rest periods long enough to restore the gear reducer to near ambient temperature (likewise 1 ÷ 3 h). In case of maximum ambient temperature above 50 °C or below 0 °C consult us.

Nominal thermal power P_{tN} [kW]

Train of gears	P_{tN} [kW]					
	80, 81	100, 101	125, 126	140	160	180
2I	15	22,4	33,5	35,5	53	56
3I	11,2	17	25	26,5	40	42,5

Thermal factor f_{t1} according to input speed n_1

Train of gears	f_{t1}				
	Input speed n_1 , [min ⁻¹] \geq				
	710	900	1 120	1 400	1 800
2I	1,18	1,12	1,06	1	0,85
3I	1,06	1,06	1,03	1	0,95

Thermal factor f_{t2} according to ambient temperature and duty

Maximum ambient temperature [°C]	f_{t2}				
	Continuous duty S1	Intermittent duty S3 ... S6			
		Cyclic duration factor for 60 min running ²⁾			
		60	40	25	15
50	0,8	0,95	1,06	1,18	1,32
40	1	1,18	1,32	1,5	1,7
30	1,18	1,4	1,6	1,8	2
20	1,32	1,6	1,8	2	2,24
10	1,5	1,8	2	2,24	2,5

Thermal factor f_{t4} according to altitude

Altitude a.s.l [m]	f_{t4}
$\leq 1\ 000$	1
1 000 ÷ 2 000	0,95
2 000 ÷ 3 000	0,9
3 000 ÷ 4 000	0,85
$\geq 4\ 000$	0,8

Thermal factor f_{t5} according to air speed on the housing

Air speed m/s	Working environment	f_{t5}
< 0,63	very small or no air movement or gear reducer shielded	consult us
0,63	small and with limited air movement	0,71
1	large and without ventilation	0,9
1,25	large and with slight ventilation (e.g. gearmotor with self-cooled motor)	1
2,5	outdoor ventilated	1,18
4	strong air movement	1,32

1) Corresponding to an average temperature of the external housing surface of approximately 85 °C; locally housing temperature can achieve the oil temperature.
 2) (Duration of running on load / 60) · 100 [%].

Service factor f_s takes into account the different running conditions (nature of load, running time, frequency of starting, other considerations) which must be referred to when performing calculations of gear reducer selection and verification.

The powers and torques shown in the catalog are nominal (i.e. valid for $f_s = 1$) for gear reducers, corresponding to the f_s indicated for gearmotors.

Service factor based: on the **nature of load** and **running time** (this value is to be multiplied by the values shown in the tables alongside).

...: on **frequency of starting** referred to the nature of load.

Natura del carico della macchina azionata Nature of load of the driven machine		Durata di funzionamento [h] Running time [h]					Rif. carico Load ref.								
Rif. Ref.	Descrizione Description	3 150 ≤ 2 h/d	6 300 2÷4 h/d	12 500 4÷8 h/d	25 000 8÷16 h/d	50 000 16÷24 h/d	Frequenza di avviamento z [avv./h] Frequency of starting z [starts/h]								
							2	4	8	16	32	63	125	250	
a	Uniforme Uniform	0,8	0,9	1	1,18	1,32	a	1	1,06	1,12	1,18	1,25	1,32	1,4	1,5
b	Sovraccarichi moderati (entità 1,6 volte il carico normale) Moderate overloads (1,6 × normal)	1	1,12	1,25	1,5	1,7	b	1	1	1,06	1,12	1,18	1,25	1,32	1,4
c	Sovraccarichi forti (entità 2,5 volte il carico normale) Heavy overloads (2,5 × normal)	1,32	1,5	1,7	2	2,24	c	1	1	1	1,06	1,12	1,18	1,25	1,32

Details of service factor, and considerations.

Given f_s values are valid for:

- electric motor with cage rotor, direct on-line starting up to 9,2 kW, star-delta starting for higher power ratings; for direct on-line starting above 9,2 kW or for brake motors, select f_s according to a frequency of starting double the actual frequency; for internal combustion engines multiply f_s by 1,25 (multicylinder) or 1,5 (single-cylinder);
- maximum time on overload 15 s; on starting 3 s; if over and/or subject to heavy shock effect, consult us;
- a whole number of overload cycles (or start) **imprecisely** completed in 1, 2, 3 or 4 revolutions of low speed shaft; if **precisely** a continuous overloads should be assumed;
- **standard** level of reliability; if a **higher** degree of reliability is required (particularly difficult maintenance conditions, key importance of gear reducer to production, personnel safety, etc.) multiply f_s by **1,25 ÷ 1,4**.

Motors having a starting torque not exceeding nominal values (star-delta starting, particular types of motor operating on direct current, and single-phase motors), and particular types of coupling between gear reducer and motor, and gear reducer and driven machine (flexible, centrifugal, fluid and safety couplings, clutches and belt drives) affect service factor favourably, allowing its reduction in certain heavy-duty applications; consult us if need be.

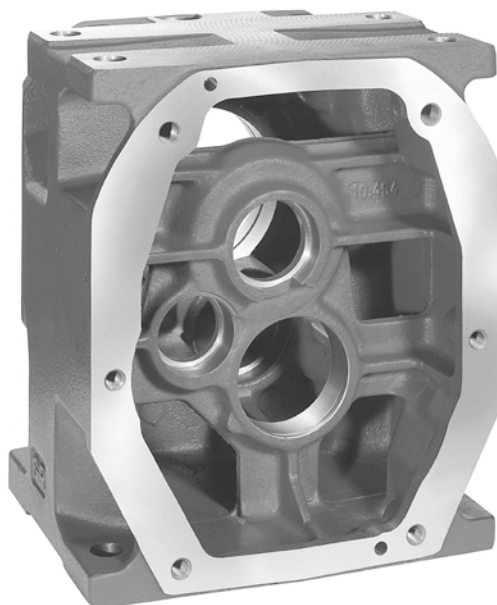

a - Gear reducer

Determining the gear reducer size

- Make available all necessary data: required output power P_2 of gear reducer, speeds n_2 and n_1 , running conditions (nature of load, running time, frequency of starting z , other considerations) with reference to ch. 5.
- Determine service factor fs on the basis of running conditions (ch. 5).
- Select the gear reducer size (also, the train of gears and transmission ratio i at the same time) on the basis of n_2 , n_1 and of a power P_{N2} greater than or equal to $P_2 \cdot fs$ (ch. 7).
- Calculate power P_1 , required at input side of gear reducer using — the formula $\frac{P_2}{\eta}$, where $\eta = 0,96 \div 0,94$ is the efficiency of the gear reducer (ch. 3.13).

When for reasons of motor standardization, power P_1 applied at input side of gear reducer turns out to be higher than the power required (considering motor/gear reducer efficiency), it must be certain that this excess power applied will never be required, and frequency of starting z is so low as not to affect service factor (ch. 3.3).

Otherwise, make the selection by multiplying P_{N2} by $\frac{P_1 \text{ applied}}{P_1 \text{ required}}$.

Calculations can also be made on the basis of torque instead of power; this method is even preferable for low n_2 values.

Verifications

- Verify possible radial loads F_{r1} , F_{r2} by referring to instructions and values given in ch. 3.11 and 3.12.
- When the load chart is available, and/or there are overloads — due to starting on full load (mainly for high inertias and low transmission ratios), braking, shocks, gear reducers in which the low speed shaft becomes driving member due to driven machine inertia, or other static or dynamic causes — verify that the maximum torque peak (ch. 3.13) is always less than $2 \cdot M_{N2}$; if it is higher or cannot be evaluated in the above cases, install a safety device so that $2 \cdot M_{N2}$ will never be exceeded.
- Verify, when $fs < 1$, that torque M_2 is less or equal to M_{N2} value valid for $n_1 \leq 90 \text{ min}^{-1}$ (see ch. 3.5).
- For the cases marked at ch. 7 with * and ** (in red) verify that $P_1 \leq Pt$ (ch. 3.2).

b - Gearmotor

Determining the gearmotor size

- Make available all necessary data: required output power P_2 of gearmotor, speed n_2 , running conditions (nature of load, running time, frequency of starting z , other considerations) with reference to ch. 3.3.
- Determine service factor fs on the basis of running conditions (ch. 3.3).
- Select the gearmotor size on the basis of n_2 , fs and of a power P_1 greater than or equal to P_2 (ch. 3.7).

If power P_2 required is the result of a precise calculation, the gearmotor should be selected on the basis of a power P_1 equal to or greater than $\frac{P_2}{\eta}$, where $\eta = 0,96 \div 0,94$ is gear reducer efficiency (ch. 3.13). The torque value M_2 has been calculated taking into account efficiency.

When for reasons of motor standardization, power P_1 available in catalogue is much greater than the power P_2 required, the gearmotor can be selected on

the basis of a lower service factor ($fs \cdot \frac{P_2 \text{ required}}{P_1 \text{ available}}$) provided it is certain that this excess power available will never be required and frequency of

starting z is low enough not to affect service factor (ch. 3.3).

Calculations can also be made on the basis of torque instead of power; this method is even preferable for low n_2 values.

Verifications

- Verify possible radial load F_{r2} referring to directions and values given in ch. 3.12.
- For the motor, verify frequency of starting z when higher than that normally permissible, referring to directions and values given in ch. 2b; this will normally be required for brake motors only.
- Verify, in case of **motors supplied by the customer**, that the **static bending moment M_b** generated by motor weight on the counter flange of gear reducer is lower than the value allowed M_{bmax} , stated in the ch. 3.13.
Loads higher than permissible loads may be present in dynamical applications where the gearmotor is subjected to translations, rotations or oscillations: consult us for the study of every specific case
- When a load chart is available, and/or there are overloads — due to starting on full load (especially with high inertias and low transmission ratios), braking, shocks, gear reducers in which the low speed shaft becomes driving member due to driven machine inertia, or other static or dynamic causes — verify that the maximum torque peak (ch. 3.13) is always less than $2 \cdot M_{N2}$ ($M_{N2} = M_2 \cdot fs$, see ch. 3.7); if it is higher or cannot be evaluated in the above instances, install suitable safety devices so that $2 \cdot M_{N2}$ will never be exceeded.
- For the cases marked at ch. 3.7 with * and ** (in red) verify that $P_1 \leq Pt$ (ch. 3.2).

c - Combined gear reducer and gearmotor units

Combined units are obtained by coupling together **normal single** gear reducers and/or gearmotors so as to produce low output speeds.

Determining the final gear reducer size and the combined unit

- Make available all necessary data relating to the output of the final gear reducer: required torque M_2 , speed n_2 , running conditions (nature of load, running time, frequency of starting z , other considerations) with reference to ch. 3.3.
- Determine service factor fs on the basis of running conditions (ch. 3.3).
- Select the final gear reducer size and basic reference, and the initial gear reducer or gearmotor size (ch. 3.9) on the basis of a torque value M_{N2} greater than or equal to $M_2 \cdot fs$.

Selection of initial gear reducer or gearmotor

- Calculate the speed n_2 and the required power P_2 at the initial gearmotor output using the following formulae:

$$n_2 \text{ initial} = n_2 \text{ final} \cdot i \text{ final}$$

$$P_2 \text{ initial} = \frac{M_2 \text{ final} \cdot n_2 \text{ final}}{955 \cdot \eta \text{ final}} \text{ [kW]}$$

- In the case of gear reducer, make available input speed n_1 at the input of the initial gear reducer.
- Make the selection of initial gear reducer or gearmotor as shown in ch. 3.4 paragraph a) or b) bearing in mind that sizes are pre-established (and cannot be changed on account of couplings being standard) and that it is not necessary to verify service factor.

Designation for ordering

When ordering combined units, the single gear reducers or gearmotors must be designated **separately**, as indicated in ch. 3.1) bearing in mind the following:

- insert the words **coupled with** between the final gear reducer designation and that of the initial gear reducer or gearmotor;
- always add the words **without motor** to the final gear reducer designation; select the design **oversized B5 flange** for the initial gear reducer or gearmotor (for size 63 also add **-Ø 28**); in case of initial gear reducer or gearmotor size 40 select with flange **FC1A** design.

E.g.: MR 3I 160 UC2A - 38 × 300 - 49,7 without motor coupled with
R 2I 80 UC2A/15,7 oversized B5 flange

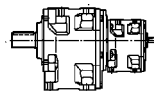

UTC 983

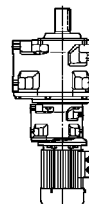

MR 3I 125 UC2A - 28 × 250 - 34,1 without motor mounting position V6
coupled with
MR 2I 63 UC2A - 19 × 200 - 24,3
oversized B5 flange - Ø 28, mounting position V6
HB3 80B 4 230.400 B5

Considerations on selection

Motor power

Taking into account the efficiency of the gear reducer, and other drives – if any – motor power is to be as near as possible to the power rating required by the driven machine: accurate calculation is therefore recommended.

The power required by the machine can be calculated, seeing that it is related directly to the power-requirement of the work to be carried out, to friction (starting, sliding or rolling friction) and inertia (particularly when mass and/or acceleration or deceleration are considerable). It can also be determined experimentally on the basis of tests, comparisons with existing applications, or readings taken with ammeters or wattmeters.

An oversized motor would involve: a greater starting current and consequently larger fuses and heavier cable; a higher running cost as power factor ($\cos \varphi$) and efficiency would suffer; greater stress on the drive, causing danger of mechanical failure, drive being normally proportionate to the power rating required by the machine, not to motor power.

Only high values of ambient temperature, altitude, frequency of starting or other particular conditions require an increase in motor power.

Input speed

Maximum input speed must be always $n_1 \leq 2\,800 \text{ min}^{-1}$; for intermittent duty or for particular needs higher speeds may be accepted: consult us.

For n_1 higher than $1\,400 \text{ min}^{-1}$, **power** and **torque** ratings relating to a given transmission ratio vary as shown in the table alongside. In this case no loads should be imposed on the high speed shaft end.

For variable n_1 , the selection should be carried out on the basis of $n_{1 \text{ max}}$; but it should also be verified on the basis of $n_{1 \text{ min}}$.

When there is a belt drive between motor and gear reducer, different input speeds n_1 should be examined in order to select the most suitable unit from engineering and economy standpoints alike (our catalogue favours this method of selection as it shows a number of input speed values n_1 relating to a determined output speed n_{N2} in the same section). Input speed should not be higher than $1\,400 \text{ min}^{-1}$, unless conditions make it necessary; better to take advantage of the transmission, and use an input speed lower than 900 min^{-1} .

n_1 min ⁻¹	R 2I		R 3I	
	P_{N2}	M_{N2}	P_{N2}	M_{N2}
2 800	1,4	0,71	1,7	0,85
2 240	1,25	0,8	1,4	0,9
1 800	1,12	0,9	1,18	0,95
1 400	1	1	1	1

Operation on 60 Hz supply

When motor is fed with 60 Hz frequency (ch. 2 b), the gearmotor specifications vary as follows.

- Speed n_2 increases by 20%.
- Power P_1 may either remain constant or increase (ch. 2 b).
- Torque M_2 and service factor f_s vary as follows:

$$M_{2 \text{ at } 60 \text{ Hz}} = M_{2 \text{ at } 50 \text{ Hz}} \cdot \frac{P_{1 \text{ at } 60 \text{ Hz}}}{1,2 \cdot P_{1 \text{ at } 50 \text{ Hz}}}$$

$$f_{s \text{ at } 60 \text{ Hz}} = f_{s \text{ at } 50 \text{ Hz}} \cdot \frac{1,12 \cdot P_{1 \text{ at } 50 \text{ Hz}}}{P_{1 \text{ at } 60 \text{ Hz}}}$$

Nominal powers and torques (gear reducers)

3.5

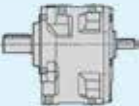
n_{N2}	n_1	i_N	Gear reducer size														
			32	40	50	51	63	64	80	81	100	101	125	126	140	160	
			P_{N2} kW M_{N2} daN m ... / i														
224	1 400	6,3	0,78 3,36 2/16,33	1,35 5,6 2/16,08	2,64 11,7 2/16,52	3,41 15,1 2/16,52	5,7 24,8 2/16,36	6,8 29,6 2/16,36	12 49,8 2/16,1	14,1 59 2/16,1	22,5 100 2/16,5	26,9* 119 2/16,5	46* 199 2/16,35	53** 231 2/16,35	-	108** 466 2/16,34	-
			180	1 400	8	0,61 3,36 2/18,12	1,31 6,8 2/17,61	2,59 14,4 2/18,13	3,61 20 2/18,13	5,5 30,3 2/18,05	6,8 37,5 2/18,05	11,6 61 2/17,64	14,4 75 2/17,64	21,8 120 2/18,11	28,5* 158 2/18,11	44,1* 241 2/18,03	55** 300 2/18,03
1 120	6,3	0,63 3,41 2/16,33				1,09 5,6 2/16,08	2,13 11,9 2/16,52	2,75 15,3 2/16,52	4,61 25 2/16,36	5,5 29,9 2/16,36	9,6 50 2/16,1	11,4 59 2/16,1	18,1 101 2/16,5	21,7 120 2/16,5	37 200 2/16,35	43,1* 233 2/16,35	-
		160	1 250	8	0,55 3,38 2/18,12	1,18 6,8 2/17,61	2,33 14,5 2/18,13	3,24 20,1 2/18,13	4,97 30,5 2/18,05	6,1 37,5 2/18,05	10,5 61 2/17,64	12,9 75 2/17,64	19,6 121 2/18,11	25,6 159 2/18,11	39,6 243 2/18,03	48,9** 300 2/18,03	-
1 000	6,3				0,57 3,43 2/16,33	0,98 5,7 2/16,08	1,91 11,9 2/16,52	2,47 15,4 2/16,52	4,11 25 2/16,36	4,94 30 2/16,36	8,6 50 2/16,1	10,2 59 2/16,1	16,3 101 2/16,5	19,5 121 2/16,5	33 200 2/16,35	38,7* 235 2/16,35	-
		140	1 400	10	0,456 3,36 2/10,8	1,02 6,8 2/19,76	2,03 14,4 2/10,4	2,88 20,4 2/10,4	4,25 30,3 2/10,5	5,7 40,7 2/10,5	9,1 61 2/9,79	12,2 81 2/9,79	17 120 2/10,4	23 163 2/10,4	33,9 241 2/10,4	45,4* 323 2/10,4	57** 383 2/9,92
1 120	8				0,492 3,41 2/18,12	1,06 6,9 2/17,61	2,11 14,6 2/18,13	2,92 20,2 2/18,13	4,48 30,8 2/18,05	5,5 37,5 2/18,05	9,4 61 2/17,64	11,5 75 2/17,64	17,6 122 2/18,11	23 159 2/18,11	35,7 245 2/18,03	43,8* 300 2/18,03	-
			900	6,3	0,51 3,45 2/16,33	0,88 5,7 2/16,08	1,73 12 2/16,52	2,23 15,4 2/16,52	3,7 25 2/16,36	4,44 30 2/16,36	7,7 50 2/16,1	9,2 60 2/16,1	14,7 101 2/16,5	17,6 122 2/16,5	29,7 200 2/16,35	35* 236 2/16,35	-
125	1 250	10	0,41 3,38 2/10,8	0,92 6,8 2/19,76	1,83 14,5 2/10,4	2,59 20,6 2/10,4	3,82 30,5 2/10,5	5,1 41 2/10,5	8,2 61 2/9,79	10,9 82 2/9,79	15,3 121 2/10,4	20,7 164 2/10,4	30,5 243 2/10,4	40,8 325 2/10,4	51** 385 2/9,92	76* 623 2/10,7	105** 867 2/10,8
			1 000	8	0,443 3,43 2/18,12	0,95 6,9 2/17,61	1,90 14,7 2/18,13	2,62 20,3 2/18,13	4,03 31 2/18,05	4,88 37,5 2/18,05	8,5 62 2/17,64	10,3 75 2/17,64	15,9 123 2/18,11	20,7 160 2/18,11	32,1 246 2/18,03	39,1* 300 2/18,03	-
	800	6,3			0,46 3,48 2/16,33	0,79 5,7 2/16,08	1,54 12 2/16,52	2 15,5 2/16,52	3,29 25 2/16,36	3,95 30 2/16,36	6,9 50 2/16,1	8,2 60 2/16,1	13,1 102 2/16,5	15,8 122 2/16,5	26,4 200 2/16,35	31 236 2/16,35	-
112	1 400	12,5	0,343 3,16 2/13,5	0,77 6,8 2/13	1,69 14,4 2/12,5	2,34 19,9 2/12,5	3,49 30,3 2/12,7	4,55 39,5 2/12,7	6,8 61 2/13	8,9 79 2/13	14,2 120 2/12,5	18,6 158 2/12,5	27,9 241 2/12,7	36,2 313 2/12,7	50* 444 2/12,9	75* 620 2/12,1	83** 709 2/12,5
			1 120	10	0,37 3,41 2/10,8	0,83 6,9 2/19,76	1,65 14,6 2/10,4	2,34 20,7 2/10,4	3,45 30,8 2/10,5	4,63 41,3 2/10,5	7,4 61 2/9,79	9,9 82 2/9,79	13,8 122 2/10,4	18,7 165 2/10,4	27,5 245 2/10,4	36,8 328 2/10,4	45,7* 387 2/9,92
	900	8			0,401 3,45 2/18,12	0,86 7 2/17,61	1,72 14,8 2/18,13	2,37 20,4 2/18,13	3,65 31,2 2/18,05	4,39 37,5 2/18,05	7,7 62 2/17,64	9,3 75 2/17,64	14,4 124 2/18,11	18,7 161 2/18,11	29,1 248 2/18,03	35,2 300 2/18,03	-
			710	6,3	0,412 3,51 2/16,33	0,7 5,8 2/16,08	1,38 12,1 2/16,52	1,78 15,6 2/16,52	2,92 25 2/16,36	3,5 30 2/16,36	6,1 50 2/16,1	7,3 60 2/16,1	11,7 102 2/16,5	14,1 123 2/16,5	23,4 200 2/16,35	27,6 236 2/16,35	-
100	1 250	12,5	0,308 3,17 2/13,5	0,69 6,8 2/13	1,52 14,5 2/12,5	2,1 20 2/12,5	3,14 30,5 2/12,7	4,1 39,8 2/12,7	6,1 61 2/13	8 80 2/13	12,7 121 2/12,5	16,7 159 2/12,5	25 243 2/12,7	32,5 315 2/12,7	45,2 447 2/12,9	68* 623 2/12,1	75* 712 2/12,5
			1 000	10	0,333 3,43 2/10,8	0,74 6,9 2/19,76	1,48 14,7 2/10,4	2,1 20,9 2/10,4	3,1 31 2/10,5	4,16 41,6 2/10,5	6,6 62 2/9,79	8,9 83 2/9,79	12,4 123 2/10,4	16,8 166 2/10,4	24,7 246 2/10,4	33,1 330 2/10,4	41* 388 2/9,92
	800	8			0,359 3,48 2/18,12	0,77 7 2/17,61	1,54 15 2/18,13	2,12 20,5 2/18,13	3,27 31,4 2/18,05	3,9 37,5 2/18,05	6,9 63 2/17,64	8,2 75 2/17,64	12,9 124 2/18,11	16,7 162 2/18,11	26 250 2/18,03	31,3 300 2/18,03	-
			630	6,3	0,368 3,53 2/16,33	0,63 5,8 2/16,08	1,23 12,1 2/16,52	1,59 15,7 2/16,52	2,59 25 2/16,36	3,11 30 2/16,36	5,4 50 2/16,1	6,5 60 2/16,1	10,4 103 2/16,5	12,6 124 2/16,5	20,8 200 2/16,35	24,5 236 2/16,35	-
90	1 400	16	-	0,58 6,4 2/16,2	1,33 14,8 2/16,3	1,72 19,2 2/16,3	2,79 31,2 2/16,4	3,39 38 2/16,4	5,8 62 2/15,7	7,2 77 2/15,7	11,1 124 2/16,3	15 168 2/16,3	23,5 244 2/15,2	30,5 317 2/15,2	42,4 448 2/15,5	58 634 2/15,9	79* 863 2/16
			1 120	12,5	0,278 3,19 2/13,5	0,62 6,9 2/13	1,37 14,6 2/12,5	1,89 20,2 2/12,5	2,84 30,8 2/12,7	3,7 40,1 2/12,7	5,5 61 2/13	7,2 80 2/13	11,5 122 2/12,5	15,1 160 2/12,5	22,6 245 2/12,7	29,3 318 2/12,7	40,8 450 2/12,9
	900	10			0,302 3,45 2/10,8	0,67 7 2/19,76	1,34 14,8 2/10,4	1,9 21 2/10,4	2,81 31,2 2/10,5	3,77 41,9 2/10,5	6 62 2/9,79	8,1 84 2/9,79	11,2 124 2/10,4	15,2 167 2/10,4	22,4 248 2/10,4	30 332 2/10,4	37,1 390 2/9,92

For $n_1 > 1400 \text{ min}^{-1}$ or $n_1 < 355 \text{ min}^{-1}$ see ch. 3.4 and the table on page 36.
 * In case of ambient temperature $> 30^\circ \text{C}$ check the thermal power (ch. 3.2).
 ** Check the thermal power (ch. 3.2).

n_{N2} n_1 min ⁻¹			i_N			Gear reducer size												
						32	40	50	51	63	64	80	81	100	101	125	126	140
90	710	8	0,321 3,51 2/8,12	0,69 7,1 2/7,61	1,38 15,1 2/8,13	1,89 20,7 2/8,13	2,93 31,7 2/8,05	3,46 37,5 2/8,05	6,2 63 2/7,64	7,3 75 2/7,64	11,5 125 2/8,11	14,9 163 2/8,11	23,3 251 2/8,03	27,8 300 2/8,03	-	61 665 2/8,12	61* 694 2/8,43	
	560	6,3	0,329 3,56 2/6,33	0,56 5,8 2/6,08	1,1 12,2 2/6,52	1,42 15,8 2/6,52	2,3 25 2/6,36	2,76 30 2/6,36	4,81 50 2/6,1	5,8 60 2/6,1	9,3 103 2/6,5	11,2 124 2/6,5	18,5 200 2/6,35	21,8 236 2/6,35	-	44,7 484 2/6,34	-	
80	1 250	16	-	0,52 6,4 2/16,2	1,2 15, 2/16,3	1,55 19,3 2/16,3	2,51 31,5 2/16,4	3,04 38,2 2/16,4	5,3 63 2/15,7	6,5 77 2/15,7	10 125 2/16,3	13,5 169 2/16,3	21,2 246 2/15,2	27,5 319 2/15,2	38,2 452 2/15,5	53 639 2/15,9	71* 867 2/16	
	1 000	12,5	0,25 3,21 2/13,5	0,56 6,9 2/13	1,24 14,7 2/12,5	1,7 20,3 2/12,5	2,55 31 2/12,7	3,33 40,4 2/12,7	4,98 62 2/13	6,5 81 2/13	10,3 123 2/12,5	13,6 161 2/12,5	20,3 246 2/12,7	26,4 320 2/12,7	36,6 453 2/12,9	55 629 2/12,1	60 719 2/12,5	
	800	10	0,27 3,48 2/10,8	0,6 7 2/9,76	1,21 15 2/10,4	1,7 21,1 2/10,4	2,52 31,4 2/10,5	3,38 42,2 2/10,5	5,4 63 2/9,79	7,2 84 2/9,79	10,1 124 2/10,4	13,6 169 2/10,4	20,1 250 2/10,4	26,9 334 2/10,4	33,1 392 2/9,92	50 641 2/10,7	69 883 2/10,8	
	630	8	0,287 3,53 2/8,12	0,62 7,1 2/7,61	1,23 15,2 2/8,13	1,68 20,8 2/8,13	2,62 31,9 2/8,05	3,07 37,5 2/8,05	5,5 64 2/7,64	6,5 75 2/7,64	10,3 126 2/8,11	13,3 164 2/8,11	20,8 253 2/8,03	24,7 300 2/8,03	-	54 670 2/8,12	55 697 2/8,43	
71	1 400	20	-	0,52 7,1 2/19,9	1,11 14,8 2/19,6	1,53 20,4 2/19,6	2,29 31,2 2/20	2,98 40,7 2/20	4,39 62 2/20,8	5,7 82 2/20,8	9,2 124 2/19,6	12,2 163 2/19,6	17,5 227 2/19	21,4 278 2/19	30,4 394 2/19	43,1 557 2/19	59 789 2/19,5	
	1 120	16	-	0,466 6,4 2/16,2	1,08 15,1 2/16,3	1,39 19,4 2/16,3	2,26 31,7 2/16,4	2,74 38,4 2/16,4	4,74 63 2/15,7	5,8 78 2/15,7	9 125 2/16,3	12,2 170 2/16,3	19,1 247 2/15,2	24,8 321 2/15,2	34,4 455 2/15,5	47,4 643 2/15,9	64 871 2/16	
	900	12,5	0,226 3,23 2/13,5	0,51 7 2/13	1,12 14,8 2/12,5	1,54 20,4 2/12,5	2,31 31,2 2/12,7	3,01 40,7 2/12,7	4,51 62 2/13	5,9 81 2/13	9,4 124 2/12,5	12,3 162 2/12,5	18,4 248 2/12,7	23,9 322 2/12,7	33,2 456 2/12,9	49,3 631 2/12,1	54 722 2/12,5	
	710	10	0,241 3,51 2/10,8	0,54 7,1 2/9,76	1,08 15,1 2/10,4	1,52 21,3 2/10,4	2,25 31,7 2/10,5	3,02 42,5 2/10,5	4,81 63 2/9,79	6,4 85 2/9,79	9 125 2/10,4	12,2 170 2/10,4	17,9 251 2/10,4	24 337 2/10,4	29,5 394 2/9,92	44,8 645 2/10,7	61 887 2/10,8	
	560	8	0,257 3,56 2/10,8	0,55 7,2 2/7,61	1,1 15,3 2/8,13	1,51 20,9 2/8,13	2,34 32,2 2/8,05	2,73 37,5 2/8,05	4,93 64 2/7,64	5,8 75 2/7,64	9,2 127 2/8,11	11,9 164 2/8,11	18,6 255 2/8,03	21,9 300 2/8,03	-	48,7 675 2/8,12	48,8 701 2/8,43	
63	1 250	20	-	0,47 7,2 2/19,9	1 15 2/19,6	1,37 20,6 2/19,6	2,06 31,5 2/20	2,68 41 2/20	3,95 63 2/20,8	5,2 82 2/20,8	8,3 125 2/19,6	10,9 164 2/19,6	15,7 228 2/19	19,3 280 2/19	27,3 397 2/19	38,7 560 2/19	53 794 2/19,5	
	1 000	16	-	0,418 6,5 2/16,2	0,97 15,2 2/16,3	1,25 19,5 2/16,3	2,03 31,9 2/16,4	2,46 38,5 2/16,4	4,26 64 2/15,7	5,2 78 2/15,7	8,1 126 2/16,3	11 171 2/16,3	17,2 249 2/15,2	22,3 323 2/15,2	30,9 458 2/15,5	42,6 648 2/15,9	57 875 2/16	
	800	12,5	0,202 3,25 2/13,5	0,454 7,0 2/13	1 15 2/12,5	1,38 20,6 2/12,5	2,07 31,4 2/12,7	2,7 41 2/12,7	4,04 63 2/13	5,3 82 2/13	8,4 124 2/12,5	11 164 2/12,5	16,5 250 2/12,7	21,4 324 2/12,7	29,7 459 2/12,9	44 634 2/12,1	48,6 725 2/12,5	
	630	10	0,216 3,53 2/10,8	0,482 7,1 2/9,76	0,96 15,2 2/10,4	1,36 21,4 2/10,4	2,01 31,9 2/10,5	2,7 42,8 2/10,5	4,3 64 2/9,79	5,8 86 2/9,79	8 126 2/10,4	10,9 171 2/10,4	16 253 2/10,4	21,5 339 2/10,4	26,4 396 2/10,4	40 650 2/10,7	55 891 2/10,8	
56	1 400	25	-	-	-	-	-	-	-	-	-	-	14,5 259 3/26,2	19,4 347 3/26,2	22,5 450 3/29,3	39,9 694 3/25,5	44,5 897 3/29,5	
	1 400	25	-	0,393 7,1 2/26,5	0,83 13,7 2/24,1	1,09 18,0 2/24,1	1,7 29, 2/25	2,08 35,4 2/25	3,27 58 2/26	4 71 2/26	7 115 2/24,1	8,6 141 2/24,1	12,5 206 2/24,3	-	-	-	-	
	1 120	20	-	0,424 7,2 2/19,9	0,9 15,1 2/19,6	1,24 20,7 2/19,6	1,86 31,7 2/20	2,42 41,3 2/20	3,57 63 2/20,8	4,65 83 2/20,8	7,5 125 2/19,6	9,9 165 2/19,6	14,2 230 2/19	17,4 281 2/19	24,6 399 2/19	34,9 564 2/19	48 799 2/19,5	
	900	16	-	0,379 6,5 2/16,2	0,88 15,3 2/16,3	1,13 19,6 2/16,3	1,84 32,1 2/16,4	2,22 38,7 2/16,4	3,86 64 2/15,7	4,71 78 2/15,7	7,3 127 2/16,3	9,9 172 2/16,3	15,5 251 2/15,2	20,2 326 2/15,2	28 461 2/15,5	38,6 652 2/15,9	52 879 2/16	
	710	12,5	0,18 3,27 2/13,5	0,406 7,1 2/13	0,9 15,1 2/12,5	1,23 20,7 2/12,5	1,85 31,7 2/12,7	2,41 41,3 2/12,7	3,61 63 2/13	4,72 83 2/13	7,5 125 2/12,5	9,9 165 2/12,5	14,7 251 2/12,7	19,1 327 2/12,7	26,5 462 2/12,9	39,3 637 2/12,1	43,3 729 2/12,5	
560	10	0,193 3,56 2/10,8	0,432 7,2 2/9,76	0,86 15,3 2/10,4	1,22 21,6 2/10,4	1,8 32,2 2/10,5	2,42 43,2 2/10,5	3,85 64 2/9,79	5,2 86 2/9,79	7,2 127 2/10,4	9,8 173 2/10,4	14,3 255 2/10,4	19,2 342 2/10,4	23,5 398 2/9,92	35,8 655 2/10,7	48,8 896 2/10,8		
50	1 250	25	-	-	-	-	-	-	-	-	-	-	13 261 3/26,2	17,4 349 3/26,2	20,3 453 3/29,3	35,9 699 3/25,5	40 904 3/29,5	

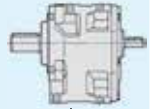

For $n_1 > 1400$ min⁻¹ or $n_1 < 355$ min⁻¹ see ch. 3.4 and the table on page 36.
 * In case of ambient temperature > 30 °C check the thermal power (ch. 3.2).

Nominal powers and torques (gear reducers)

3.5

n_{N2}	n_1	i_N	Gear reducer size														
			32	40	50	51	63	64	80	81	100	101	125	126	140	160	180
			P_{N2} kW M_{N2} daN m ... / i														
50	1 250	25	-	0,354 7,2 2/26,5	0,75 13,8 2/24,1	0,98 18,1 2/24,1	1,53 29,1 2/25	1,87 35,6 2/25	2,94 58 2/26	3,59 71 2/26	6,3 116 2/24,1	7,7 142 2/24,1	11,2 207 2/24,3	-	-	-	-
	1 000	20	-	0,381 7,3 2/19,9	0,81 15,2 2/19,6	1,11 20,8 2/19,6	1,67 31,9 2/20	2,18 41,6 2/20	3,21 64 2/20,8	4,19 83 2/20,8	6,7 126 2/19,6	8,9 166 2/19,6	12,7 231 2/19	15,6 283 2/19	22,1 402 2/19	31,3 567 2/19	43,1 804 2/19,5
	800	16	-	0,339 6,6 2/16,2	0,79 15,4 2/16,3	1,01 19,7 2/16,3	1,65 32,3 2/16,4	1,98 38,9 2/16,4	3,46 65 2/15,7	4,21 79 2/15,7	6,6 128 2/16,3	8,9 174 2/16,3	13,9 252 2/15,2	18,1 328 2/15,2	25 462 2/15,5	34,6 656 2/15,9	46,2 883 2/16
	630	12,5	0,161 3,29 2/13,5	0,363 7,1 2/13	0,8 15,2 2/12,5	1,1 20,9 2/12,5	1,65 31,9 2/12,7	2,16 41,6 2/12,7	3,23 64 2/13	4,22 83 2/13	6,7 126 2/12,5	8,8 166 2/12,5	13,2 253 2/12,7	17,1 329 2/12,7	23,6 462 2/12,9	35 640 2/12,9	38,6 732 2/12,5
45	1 400	31,5	-	-	0,71 15,5 3/31,9	1 21,8 3/31,9	1,4 32,7 3/34,2	1,88 43,9 3/34,2	2,93 65 3/32,8	3,93 88 3/32,8	5,9 129 3/32	8 175 3/32	11,1 259 3/34,1	14,9 347 3/34,1	22,1 489 3/32,4	31,1 694 3/32,7	42,3 978 3/33,9
	1 400	31,5	-	0,293 6,6 2/33,1	0,63 12,6 2/29,3	-	1,19 26 2/31,9	-	2,4 52 2/31,8	-	5,4 107 2/29,3	-	-	-	-	-	-
	1 120	25	-	-	-	-	-	-	-	-	-	-	11,7 262 3/26,2	15,7 351 3/26,2	18,3 457 3/29,3	32,3 703 3/25,5	36,1 910 3/29,5
	1 120	25	-	0,319 7,2 2/26,5	0,67 13,8 2/24,1	0,88 18,2 2/24,1	1,37 29,3 2/25	1,68 35,8 2/26	2,65 59 2/26	3,23 72 2/26	5,7 117 2/24,1	6,9 143 2/24,1	10,1 208 2/24,3	-	-	-	-
	900	20	-	0,345 7,3 2/19,9	0,73 15,3 2/19,6	1,01 21 2/19,6	1,51 32,1 2/20	1,97 41,9 2/20	2,91 64 2/20,8	3,79 84 2/19,6	5,7 127 2/19,6	6,9 167 2/19,6	11,5 232 2/19	14,1 285 2/19	20 404 2/19	28,4 570 2/19	39 808 2/19,5
	710	16	-	0,302 6,6 2/16,2	0,71 15,5 2/16,3	0,9 19,8 2/16,3	1,47 32,6 2/16,4	1,77 39,1 2/16,4	3,09 65 2/15,7	3,76 79 2/15,7	5,9 129 2/16,3	8 175 2/16,3	12,4 254 2/15,2	16,2 330 2/15,2	22,2 462 2/15,5	30,9 661 2/15,9	41,2 887 2/16
	560	12,5	0,144 3,31 2/13,5	0,325 7,2 2/13	0,72 15,3 2/12,5	0,99 21 2/12,5	1,48 32,2 2/12,7	1,93 41,9 2/12,7	2,89 64 2/13	3,78 84 2/13	6 127 2/12,5	7,9 168 2/12,5	11,8 255 2/12,7	15,3 332 2/12,7	20,9 462 2/12,9	31,3 643 2/12,9	34,5 736 2/12,5
40	1 250	31,5	-	-	0,64 15,6 3/31,9	0,9 22 3/31,9	1,26 32,9 3/34,2	1,69 44,2 3/34,2	2,63 66 3/32,8	3,53 88 3/32,8	5,3 129 3/32	7,2 176 3/32	10 261 3/34,1	13,4 349 3/34,1	19,9 492 3/32,4	28 699 3/32,7	38 984 3/33,9
	1 250	31,5	-	0,263 6,6 2/33,1	0,57 12,7 2/29,3	-	1,07 26,1 2/31,9	-	2,16 52 2/31,8	-	4,81 108 2/29,3	-	-	-	-	-	-
	1 000	25	-	-	-	-	-	-	-	-	-	-	10,5 264 3/26,2	14,1 354 3/26,2	16,5 460 3/29,3	29,1 707 3/25,5	32,5 916 3/29,5
	1 000	25	-	0,287 7,3 2/26,5	0,6 13,9 2/24,1	0,79 18,3 2/24,1	1,23 29,5 2/25	1,51 36 2/25	2,38 59 2/26	2,9 72 2/26	5,1 117 2/24,1	6,2 144 2/24,1	9 209 2/24,3	-	-	-	-
	800	20	-	0,309 7,4 2/19,9	0,66 15,4 2/19,6	0,9 21,1 2/19,6	1,35 32,3 2/20	1,77 42,2 2/20	2,6 65 2/20,8	3,4 84 2/20,8	5,5 128 2/19,6	7,2 169 2/19,6	10,3 233 2/19	12,6 287 2/19	17,9 406 2/19	25,4 574 2/19	34,9 813 2/19,5
630	16	-	0,27 6,6 2/16,2	0,63 15,7 2/16,3	0,8 19,9 2/16,3	1,32 32,8 2/16,4	1,58 39,3 2/16,4	2,76 66 2/15,7	3,35 80 2/15,7	5,2 130 2/16,3	7,1 176 2/16,3	11,1 256 2/15,2	14,4 333 2/15,2	19,7 462 2/15,5	27,6 666 2/15,9	36,8 891 2/16	
35,5	1 400	40	-	0,215 5,9 2/40,4	0,59 15,5 3/38,4	0,81 21,2 3/38,4	1,15 32,7 3/41,6	1,5 42,6 3/41,6	2,2 65 3/43,6	2,87 85 3/43,6	4,91 129 3/38,4	6,5 170 3/38,4	9,2 259 3/41,5	11,9 337 3/41,5	16,5 476 3/42,3	22,9 674 3/43,1	32,3 953 3/43,3
	1 120	31,5	-	-	0,58 15,8 3/31,9	0,81 22,1 3/31,9	1,14 33,1 3/34,2	1,53 44,5 3/34,2	2,37 66 3/32,8	3,19 89 3/32,8	4,78 130 3/32	6,5 177 3/32	9 262 3/34,1	12,1 351 3/34,1	17,9 495 3/32,4	25,2 703 3/32,7	34,3 990 3/33,9
	1 120	31,5	-	0,237 6,7 2/33,1	0,51 12,7 2/29,3	-	0,96 26,2 2/31,9	-	1,94 53 2/31,8	-	4,33 108 2/29,3	-	-	-	-	-	-
	900	25	-	-	-	-	-	-	-	-	-	-	9,5 265 3/26,2	12,8 355 3/26,2	14,9 463 3/29,3	26,2 710 3/25,5	29,4 922 3/29,5
	900	25	-	0,26 7,3 2/26,5	0,55 14 2/24,1	0,72 18,4 2/24,1	1,12 29,6 2/25	1,37 36,2 2/25	2,15 59 2/26	2,63 72 2/26	4,61 118 2/24,1	5,7 144 2/24,1	8,2 210 2/24,3	-	-	-	-

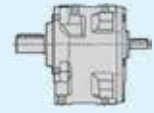

For $n_1 > 1\ 400\ \text{min}^{-1}$ or $n_1 < 355\ \text{min}^{-1}$ see ch. 3.4 and the table on page 36.

n_{N2} min ⁻¹	n_1	i_N	Gear reducer size														
			P_{N2} kW M_{N2} daN m ... / i														
			32	40	50	51	63	64	80	81	100	101	125	126	140	160	180
35,5	710	20	-	0,276 7,4 21/19,9	0,59 15,5 21/19,6	0,81 21,3 21/19,6	1,21 32,6 21/20	1,58 42,5 21/20	2,33 65 21/20,8	3,04 85 21/20,8	4,88 129 21/19,6	6,4 170 21/19,6	9,2 235 21/19	11,3 289 21/19	16 409 21/19	22,7 578 21/19	31,2 819 21/19,5
	560	16	-	0,241 6,7 21/16,2	0,57 15,8 21/16,3	0,72 20 21/16,3	1,18 33,1 21/16,4	1,41 39,5 21/16,4	2,47 66 21/15,7	2,99 80 21/15,7	4,68 130 21/16,3	6,4 177 21/16,3	9,9 258 21/15,2	12,9 335 21/15,2	17,5 462 21/15,5	24,7 671 21/15,9	32,8 896 21/16
31,5	1 250	40	-	0,193 6 21/40,4	0,53 15,6 31/38,4	0,73 21,4 31/38,4	1,04 32,9 31/41,6	1,35 42,9 31/41,6	1,98 66 31/43,6	2,58 86 31/43,6	4,41 129 31/38,4	5,8 171 31/38,4	8,2 261 31/41,5	10,7 339 31/41,5	14,8 479 31/42,3	20,6 679 31/43,1	29 959 31/43,3
	1 000	31,5	-	-	0,52 15,9 31/31,9	0,73 22,2 31/31,9	1,02 33,4 31/34,2	1,37 44,8 31/34,2	2,13 67 31/32,8	2,87 90 31/32,8	4,29 131 31/32	5,8 179 31/32	8,1 264 31/34,1	10,9 354 31/34,1	16,1 498 31/32,4	22,7 707 31/32,7	30,8 997 31/33,9
	1 000	31,5	-	0,213 6,7 21/33,1	0,457 12,8 21/29,3	-	0,86 26,4 21/31,9	-	1,74 53 21/31,8	-	3,88 109 21/29,3	-	-	-	-	-	-
	800	25	-	-	-	-	-	-	-	-	-	-	8,5 265 31/26,2	11,3 355 31/26,2	13,4 467 31/29,3	23,3 710 31/25,5	26,3 928 31/29,5
	800	25	-	0,233 7,4 21/26,5	0,49 14,1 21/24,1	0,64 18,5 21/24,1	1 29,8 21/25	1,22 36,5 21/25	1,92 60 21/26	2,35 73 21/26	4,13 119 21/24,1	5,1 145 21/24,1	7,3 211 21/24,3	-	-	-	-
	630	20	-	0,247 7,5 21/19,9	0,53 15,7 21/19,6	0,72 21,4 21/19,6	1,08 32,8 21/20	1,41 42,8 21/20	2,08 66 21/20,8	2,71 86 21/20,8	4,36 130 21/19,6	5,8 171 21/19,6	8,2 236 21/19	10,1 290 21/19	14,3 412 21/19	20,2 581 21/19	27,8 824 21/19,5
28	1 400	50	-	-	0,443 16 31/53	0,62 22,4 31/53	0,97 33,5 31/50,4	1,31 45 31/50,4	1,97 67 31/49,8	2,65 90 31/49,8	3,65 132 31/53,1	4,97 180 31/53,1	7,7 265 31/50,2	10,3 355 31/50,2	13,9 481 31/50,8	20,9 710 31/49,7	26,8 964 31/52,7
	1 120	40	-	0,173 6 21/40,4	0,482 15,8 31/38,4	0,66 21,5 31/38,4	0,93 33,1 31/41,6	1,22 43,2 31/41,6	1,79 66 31/43,6	2,33 87 31/43,6	3,98 130 31/38,4	5,3 172 31/38,4	7,4 262 31/41,5	9,7 341 31/41,5	13,4 482 31/42,3	18,6 683 31/43,1	26,1 965 31/43,3
	900	31,5	-	-	0,471 16 31/31,9	0,66 22,4 31/31,9	0,92 33,5 31/34,2	1,24 45 31/34,2	1,93 67 31/32,8	2,59 90 31/32,8	3,88 132 31/32	5,3 180 31/32	7,3 265 31/34,1	9,8 355 31/34,1	14,5 500 31/32,4	20,5 710 31/32,7	27,8 1 000 31/33,9
	900	31,5	-	0,192 6,8 21/33,1	0,413 12,8 21/29,3	-	0,78 26,5 21/31,9	-	1,57 53 21/31,8	-	3,51 109 21/29,3	-	-	-	-	-	-
	710	25	-	-	-	-	-	-	-	-	-	265	355 31/26,2	471 31/26,2	710 31/29,3	935 31/25,5	23,5 31/29,5
	710	25	-	0,208 7,4 21/26,5	0,437 14,2 21/24,1	0,57 18,6 21/24,1	0,89 30 21/25	1,09 36,7 21/25	1,72 60 21/26	2,1 73 21/26	3,68 119 21/24,1	4,52 146 21/24,1	6,5 212 21/24,3	-	-	-	-
560	20	-	0,221 7,5 21/19,9	0,472 15,8 21/19,6	0,64 21,5 21/19,6	0,97 33,1 21/20	1,26 43,1 21/20	1,86 66 21/20,8	2,43 86 21/20,8	3,9 130 21/19,6	5,2 173 21/19,6	7,3 237 21/19	9 292 21/19	12,8 414 21/19	18,1 585 21/19	24,9 829 21/19,5	
25	1 250	50	-	-	0,395 16 31/53	0,55 22,4 31/53	0,87 33,5 31/50,4	1,17 45 31/50,4	1,76 67 31/49,8	2,36 90 31/49,8	3,25 132 31/53,1	4,44 180 31/53,1	6,9 265 31/50,2	9,2 355 31/50,2	12,5 484 31/50,8	18,7 710 31/49,7	24,1 970 31/52,7
	1 000	40	-	0,156 6 21/40,4	0,433 15,9 31/38,4	0,59 21,6 31/38,4	0,84 33,4 31/41,6	1,1 43,5 31/41,6	1,6 67 31/43,6	2,1 87 31/43,6	3,57 131 31/38,4	4,73 174 31/38,4	6,7 264 31/41,5	8,7 344 31/41,5	12 485 31/42,3	16,7 687 31/43,1	23,5 972 31/43,3
	800	31,5	-	-	0,42 16 31/31,9	0,59 22,4 31/31,9	0,82 33,5 31/34,2	1,1 45 31/34,2	1,71 67 31/32,8	2,3 90 31/32,8	3,46 132 31/32	4,71 180 31/32	6,5 265 31/34,1	8,7 355 31/34,1	12,9 500 31/32,4	18,2 710 31/32,7	24,7 1 000 31/33,9
	800	31,5	-	0,172 6,8 21/33,1	0,369 12,9 21/29,3	-	0,7 26,6 21/31,9	-	1,4 53 21/31,8	-	3,13 109 21/29,3	-	-	-	-	-	-
	630	25	-	-	-	-	-	-	-	-	-	-	265 31/26,2	355 31/26,2	474 31/29,3	710 31/25,5	942 31/29,5
	630	25	-	0,186 7,5 21/26,5	0,39 14,3 21/24,1	0,51 18,7 21/24,1	0,8 30,2 21/25	0,97 36,9 21/25	1,53 60 21/26	1,87 74 21/26	3,29 120 21/24,1	4,03 147 21/24,1	5,8 213 21/24,3	-	-	-	-

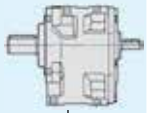

For $n_1 > 1 400 \text{ min}^{-1}$ or $n_1 < 355 \text{ min}^{-1}$ see ch. 3.4 and the table on page 36.

Nominal powers and torques (gear reducers)

3.5

n_{N2}	n_1	i_N	Gear reducer size														
			32	40	50	51	63	64	80	81	100	101	125	126	140	160	180
			P_{N2} kW M_{N2} daN m ... //														
22,4	1 400	63	-	-	0,369 16 3/163,6	0,5 21,8 3/163,6	0,8 33,5 3/161,3	1,04 43,7 3/161,3	1,48 67 3/166,3	1,94 88 3/166,3	3,04 132 3/163,8	4,02 175 3/163,8	6,3 265 3/161,2	8,3 345 3/161,2	11,4 487 3/162,3	15,4 690 3/165,6	21,7 975 3/165,9
	1 120	50	-	-	0,354 16 3/153	0,496 22,4 3/153	0,78 33,5 3/150,4	1,05 45 3/150,4	1,58 67 3/149,8	2,12 90 3/149,8	2,92 132 3/153,1	3,98 180 3/153,1	6,2 265 3/150,2	8,3 355 3/150,2	11,3 487 3/150,8	16,7 710 3/149,7	21,7 975 3/152,7
	900	40	-	0,141 6 2/140,4	0,393 16 3/138,4	0,54 21,8 3/138,4	0,76 33,5 3/141,6	0,99 43,7 3/141,6	1,45 67 3/143,6	1,89 88 3/143,6	3,23 132 3/138,4	4,29 175 3/138,4	6 265 3/141,5	7,8 345 3/141,5	10,9 487 3/142,3	15,1 690 3/143,1	21,2 975 3/143,3
	710	31,5	-	-	0,372 16 3/131,9	0,52 22,4 3/131,9	0,73 33,5 3/134,2	0,98 45 3/134,2	1,52 67 3/132,8	2,04 90 3/132,8	3,07 132 3/132	4,18 180 3/132	5,8 265 3/134,1	7,7 355 3/134,1	11,5 500 3/132,4	16,2 710 3/132,7	21,9 1 000 3/133,9
	710	31,5	-	0,154 6,8 2/133,1	0,329 13 2/129,3	-	0,62 26,7 2/131,9	-	1,25 54 2/131,8	-	2,79 110 2/129,3	-	-	-	-	-	-
	560	25	-	-	-	-	-	-	-	-	-	-	5,9 265 3/126,2	7,9 355 3/126,2	9,6 478 3/129,3	16,3 710 3/125,5	18,8 948 3/129,5
	560	25	-	0,166 7,5 2/126,5	0,349 14,3 2/124,1	0,458 18,8 2/124,1	0,71 30,4 2/125	0,87 37,1 2/125	1,37 61 2/126	1,67 74 2/126	2,94 121 2/124,1	3,61 148 2/124,1	5,2 214 2/124,3	-	-	-	-
18	1 400	80	-	-	0,272 14,5 3/178,2	0,356 19 3/178,2	0,59 30,7 3/176,7	0,72 37,5 3/176,7	1,09 62 3/182,7	1,33 75 3/182,7	2,28 122 3/178,3	2,81 150 3/178,3	4,66 243 3/176,5	5,7 300 3/176,5	8,1 425 3/176,5	12,9 690 3/178,5	18,1 975 3/178,9
	1 120	63	-	-	0,295 16 3/163,6	0,402 21,8 3/163,6	0,64 33,5 3/161,3	0,84 43,7 3/161,3	1,19 67 3/166,3	1,55 88 3/166,3	2,43 132 3/163,8	3,22 175 3/163,8	5,1 265 3/161,2	6,6 345 3/161,2	9,2 487 3/162,3	12,3 690 3/165,6	17,3 975 3/165,9
	900	50	-	-	0,285 16 3/153	0,398 22,4 3/153	0,63 33,5 3/150,4	0,84 45,0 3/150,4	1,27 67 3/149,8	1,7 90 3/149,8	2,34 132 3/153,1	3,2 180 3/153,1	4,97 265 3/150,2	6,7 355 3/150,2	9 487 3/150,8	13,5 710 3/149,7	17,4 975 3/152,7
	710	40	-	0,112 6,1 2/140,4	0,31 16 3/138,4	0,423 21,8 3/138,4	0,6 33,5 3/141,6	0,78 43,7 3/141,6	1,14 67 3/143,6	1,49 88 3/143,6	2,55 132 3/138,4	3,39 175 3/138,4	4,75 265 3/141,5	6,2 345 3/141,5	8,6 487 3/142,3	11,9 690 3/143,1	16,7 975 3/143,3
	560	31,5	-	-	0,294 16 3/131,9	0,411 22,4 3/131,9	0,58 33,5 3/134,2	0,77 45 3/134,2	1,2 67 3/132,8	1,61 90 3/132,8	2,42 132 3/132	3,3 180 3/132	4,56 265 3/134,1	6,1 355 3/134,1	9 500 3/132,4	12,7 710 3/132,7	17,3 1 000 3/133,9
	560	31,5	-	0,122 6,9 2/133,1	0,262 13,1 2/129,3	-	0,495 27 2/131,9	-	1 54 2/131,8	-	2,22 111 2/129,3	-	-	-	-	-	-
14	1 400	100	-	-	0,23 16 3/1102	0,313 21,8 3/1102	0,51 33,5 3/106,4	0,66 43,7 3/106,4	0,94 67 3/1104	1,23 88 3/1104	1,90 132 3/1102	2,52 175 3/1102	4,03 265 3/106,4	5,2 345 3/106,4	7,3 487 3/108,2	10,1 690 3/1100	13,6 937 3/1101
	1 120	80	-	-	0,218 14,5 3/178,2	0,285 19 3/178,2	0,47 30,7 3/176,7	0,57 37,5 3/176,7	0,87 62 3/182,7	1,06 75 3/182,7	1,83 122 3/178,3	2,25 150 3/178,3	3,73 243 3/176,5	4,60 300 3/176,5	6,5 425 3/176,5	10,3 690 3/178,5	14,5 975 3/178,9
	900	63	-	-	0,237 16 3/163,6	0,323 21,8 3/163,6	0,51 33,5 3/161,3	0,67 43,7 3/161,3	0,95 67 3/166,3	1,24 88 3/166,3	1,95 132 3/163,8	2,59 175 3/163,8	4,08 265 3/161,2	5,3 345 3/161,2	7,4 487 3/162,3	9,9 690 3/165,6	13,9 975 3/165,9
	710	50	-	-	0,224 16 3/153	0,314 22,4 3/153	0,494 33,5 3/150,4	0,66 45 3/150,4	1 67 3/149,8	1,34 90 3/149,8	1,85 132 3/153,1	2,52 180 3/153,1	3,92 265 3/150,2	5,3 355 3/150,2	7,1 487 3/150,8	10,6 710 3/149,7	13,7 975 3/152,7
	560	40	-	0,089 6,2 2/140,4	0,245 16 3/138,4	0,333 21,8 3/138,4	0,472 33,5 3/141,6	0,62 43,7 3/141,6	0,9 67 3/143,6	1,18 88 3/143,6	2,02 132 3/138,4	2,67 175 3/138,4	3,75 265 3/141,5	4,88 345 3/141,5	6,8 487 3/142,3	9,4 690 3/143,1	13,2 975 3/143,3
11,2	1 400	125	-	-	0,17 14,5 3/1125	0,222 19 3/1125	0,374 30,7 3/1120	0,456 37,5 3/1120	0,74 67 3/1133	0,96 88 3/1133	1,55 132 3/1125	2,06 175 3/1125	3,32 265 3/1117	4,32 345 3/1117	6 487 3/1119	7,4 600 3/1119	10,1 850 3/1123
	1 120	100	-	-	0,184 16 3/1102	0,251 21,8 3/1102	0,408 33,5 3/106,4	0,53 43,7 3/106,4	0,75 67 3/1104	0,99 88 3/1104	1,52 132 3/1102	2,01 175 3/1102	3,23 265 3/106,4	4,2 345 3/106,4	5,8 487 3/108,2	8,1 690 3/1100	11 945 3/1101
	900	80	-	-	0,175 14,5 3/178,2	0,229 19 3/178,2	0,377 30,7 3/176,7	0,461 37,5 3/176,7	0,7 62 3/182,7	0,85 75 3/182,7	1,47 122 3/178,3	1,81 150 3/178,3	3 243 3/176,5	3,7 300 3/176,5	5,2 425 3/176,5	8,3 690 3/178,5	11,6 975 3/178,9
	710	63	-	-	0,187 16 3/163,6	0,255 21,8 3/163,6	0,406 33,5 3/161,3	0,53 43,7 3/161,3	0,75 67 3/166,3	0,98 88 3/166,3	1,54 132 3/163,8	2,04 175 3/163,8	3,22 265 3/161,2	4,19 345 3/161,2	5,8 487 3/162,3	7,8 690 3/165,6	11 975 3/165,9

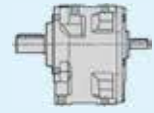

For $n_1 > 1 400 \text{ min}^{-1}$ or $n_1 < 355 \text{ min}^{-1}$ see ch. 3.4 and the table on page 36.

Nominal powers and torques (gear reducers)

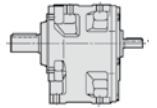

n_{N2}	n_1	i_N	Gear reducer size														
			P_{N2} kW M_{N2} daN m ... / i														
			32	40	50	51	63	64	80	81	100	101	125	126	140	160	180
11,2	560	50	-	-	0,177 16 3/153	0,248 22,4 3/153	0,39 33,5 3/150,4	0,52 45 3/150,4	0,79 67 3/149,8	1,06 90 3/149,8	1,46 132 3/153,1	1,99 180 3/153,1	3,09 265 3/150,2	4,14 355 3/150,2	5,6 487 3/150,8	8,4 710 3/149,7	10,8 975 3/152,7
9	1 400	160	-	-	0,127 13,2 3/152	-	0,259 27,2 3/154	-	0,54 62 3/166	0,66 75 3/166	1,17 122 3/153	1,44 150 3/153	2,43 243 3/146	3 300 3/146	4,25 425 3/146	-	-
	1 120	125	-	-	0,136 14,5 3/125	0,178 19 3/125	0,299 30,7 3/120	0,365 37,5 3/120	0,59 67 3/133	0,77 88 3/133	1,24 132 3/125	1,65 175 3/125	2,65 265 3/117	3,45 345 3/117	4,78 487 3/119	5,9 600 3/119	8,1 850 3/123
	900	100	-	-	0,148 16 3/102	0,201 21,8 3/102	0,328 33,5 3/96,4	0,427 43,7 3/96,4	0,61 67 3/104	0,79 88 3/104	1,22 132 3/102	1,62 175 3/102	2,59 265 3/96,4	3,37 345 3/96,4	4,67 487 3/98,2	6,5 690 3/100	8,9 953 3/101
	710	80	-	-	0,138 14,5 3/178,2	0,181 19 3/178,2	0,298 30,7 3/176,7	0,364 37,5 3/176,7	0,55 62 3/182,7	0,67 75 3/182,7	1,16 122 3/178,3	1,42 150 3/178,3	2,36 243 3/176,5	2,92 300 3/176,5	4,13 425 3/176,5	6,5 690 3/178,5	9,2 975 3/178,9
	560	63	-	-	0,147 16 3/163,6	0,201 21,8 3/163,6	0,32 33,5 3/161,3	0,418 43,7 3/161,3	0,59 67 3/166,3	0,77 88 3/166,3	1,21 132 3/163,8	1,61 175 3/163,8	2,54 265 3/161,2	3,31 345 3/161,2	4,58 487 3/162,3	6,2 690 3/165,6	8,7 975 3/165,9
7,1	1 400	200	-	-	-	-	-	-	0,394 55 3/203	-	0,88 112 3/186	-	1,71 218 3/187	-	-	-	-
	1 120	160	-	-	0,102 13,2 3/152	-	0,207 27,2 3/154	-	0,434 62 3/166	0,53 75 3/166	0,93 122 3/153	1,15 150 3/153	1,95 243 3/146	2,4 300 3/146	3,4 425 3/146	-	-
	900	125	-	-	0,109 14,5 3/125	0,143 19 3/125	0,24 30,7 3/120	0,293 37,5 3/120	0,475 67 3/133	0,62 88 3/133	1 132 3/125	1,32 175 3/125	2,13 265 3/117	2,78 345 3/117	3,84 487 3/119	4,73 600 3/119	6,5 850 3/123
	710	100	-	-	0,117 16 3/102	0,159 21,8 3/102	0,258 33,5 3/96,4	0,337 43,7 3/96,4	0,478 67 3/104	0,62 88 3/104	0,96 132 3/102	1,28 175 3/102	2,04 265 3/96,4	2,66 345 3/96,4	3,69 487 3/98,2	5,1 690 3/100	7,1 962 3/101
	560	80	-	-	0,109 14,5 3/178,2	0,143 19 3/178,2	0,235 30,7 3/176,7	0,287 37,5 3/176,7	0,436 62 3/182,7	0,53 75 3/182,7	0,91 122 3/178,3	1,12 150 3/178,3	1,86 243 3/176,5	2,3 300 3/176,5	3,26 425 3/176,5	5,2 690 3/178,5	7,2 975 3/178,9
5,6	1 120	200	-	-	-	-	-	-	0,315 55 3/203	-	0,71 112 3/186	-	1,37 218 3/187	-	-	-	-
	900	160	-	-	0,082 13,2 3/152	-	0,167 27,2 3/154	-	0,349 62 3/166	0,426 75 3/166	0,75 122 3/153	0,92 150 3/153	1,56 243 3/146	1,93 300 3/146	2,74 425 3/146	-	-
	710	125	-	-	0,086 14,5 3/125	0,113 19 3/125	0,189 30,7 3/120	0,231 37,5 3/120	0,374 67 3/133	0,489 88 3/133	0,79 132 3/125	1,04 175 3/125	1,68 265 3/117	2,19 345 3/117	3,03 487 3/119	3,73 600 3/119	5,1 850 3/123
	560	100	-	-	0,092 16 3/102	0,125 21,8 3/102	0,204 33,5 3/96,4	0,266 43,7 3/96,4	0,377 67 3/104	0,493 88 3/104	0,76 132 3/102	1,01 175 3/102	1,61 265 3/96,4	2,1 345 3/96,4	2,91 487 3/98,2	4,03 690 3/100	5,6 971 3/101

For $n_1 > 1\ 400\ \text{min}^{-1}$ or $n_1 < 355\ \text{min}^{-1}$ see ch. 3.4 and the table on page 36.

Nominal powers and torques (gear reducers)

3.5

Summary of transmission ratios i , torques M_{N2} [daN m] valid for $n_1 \leq 90 \text{ min}^{-1}$

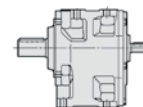

Train of gears	Gear reducer size																														
	i_N	32		40		50		51		63		64		80		81		100		101		125		126		140		160		180	
		i	M_{N2}	i	M_{N2}	i	M_{N2}	i	M_{N2}	i	M_{N2}	i	M_{N2}	i	M_{N2}	i	M_{N2}	i	M_{N2}	i	M_{N2}	i	M_{N2}	i	M_{N2}	i	M_{N2}	i	M_{N2}	i	M_{N2}
2I	6,3	6,33	3,75	6,08	6	6,52	12,5	6,52	16	6,36	25	6,36	30	6,1	50	6,1	60	6,5	106	6,5	125	6,35	200	6,35	236	—	6,34	519	—	—	—
	8	8,12	3,75	7,61	7,5	8,13	16	8,13	22,4	8,05	33,5	8,05	37,5	7,64	67	7,64	75	8,11	132	8,11	170	8,03	265	8,03	300	—	8,12	675	8,43	752	—
	10	10,8	3,75	9,76	7,5	10,4	16	10,4	22,4	10,5	33,5	10,5	45	9,79	67	9,79	90	10,4	132	10,4	180	10,4	265	10,4	345	9,92	400	10,7	690	10,8	900
	12,5	13,5	3,45	13	7,5	12,5	16	12,5	21,8	12,7	33,5	12,7	43,7	13	67	13	88	12,5	132	12,5	175	12,7	265	12,7	345	12,9	462	12,1	675	12,5	752
	16	—	—	16,2	6,9	16,3	16	16,3	21,4	16,4	33,5	16,4	42,5	15,7	67	15,7	86	16,3	132	16,3	180	15,2	265	15,2	345	15,5	462	15,9	690	16	900
	20	—	—	19,9	7,5	19,6	16	19,6	21,8	20	33,5	20	43,7	20,8	67	20,8	88	19,6	132	19,6	175	19	243	19	300	19	425	19	600	19,5	850
	25	—	—	26,5	7,5	24,1	14,5	24,1	19	25	30,7	25	37,5	26	62	26	75	24,1	122	24,1	150	24,3	218	—	—	—	—	—	—	—	—
	31,5	—	—	33,1	6,9	29,3	13,2	—	—	31,9	27,2	—	—	31,8	55	—	—	29,3	112	—	—	—	—	—	—	—	—	—	—	—	—
40	—	—	40,4	6,2	—	—	—	—	—	—	—	—	—	—	—	—	—	—	—	—	—	—	—	—	—	—	—	—	—	—	—
3I	25	—	—	—	—	—	—	—	—	—	—	—	—	—	—	—	—	—	—	—	26,2	265	26,2	355	29,3	498	25,5	710	29,5	975	
	31,5	—	—	31,9	16	31,9	22,4	34,2	33,5	34,2	45	32,8	67	32,8	90	32	132	32	180	34,1	265	34,1	355	32,4	500	32,7	710	33,9	1000		
	40	—	—	38,4	16	38,4	21,8	41,6	33,5	41,6	43,7	43,6	67	43,6	88	38,4	132	38,4	175	41,5	265	41,5	345	42,3	487	43,1	690	43,3	975		
	50	—	—	53	16	53	22,4	50,4	33,5	50,4	45	49,8	67	49,8	90	53,1	132	53,1	180	50,2	265	50,2	355	50,8	487	49,7	710	52,7	975		
	63	—	—	63,6	16	63,6	21,8	61,3	33,5	61,3	43,7	66,3	67	66,3	88	63,8	132	63,8	175	61,2	265	61,2	345	62,3	487	65,6	690	65,9	975		
	80	—	—	78,2	14,5	78,2	19	76,7	30,7	76,7	37,5	82,7	62	82,7	75	78,3	122	78,3	150	76,5	243	76,5	300	76,5	300	76,5	425	78,5	690	78,9	975
	100	—	—	102	16	102	21,8	96,4	33,5	96,4	43,7	104	67	104	88	102	132	102	175	96,4	265	96,4	345	98,2	487	100	690	101	975		
	125	—	—	125	14,5	125	19	120	30,7	120	37,5	133	67	133	88	125	132	125	175	117	265	117	345	119	487	119	600	123	850		
160	—	—	152	13,2	—	—	154	27,2	—	—	166	62	166	75	153	122	153	150	146	243	146	300	146	425	—	—	—	—	—		
200	—	—	—	—	—	—	—	—	—	—	203	55	—	—	186	112	—	—	—	—	187	218	—	—	—	—	—	—	—	—	

blank page

Designs, dimensions, mounting positions and lubricant quantities 3.6

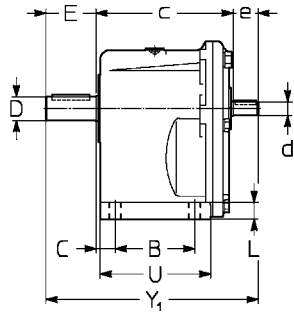
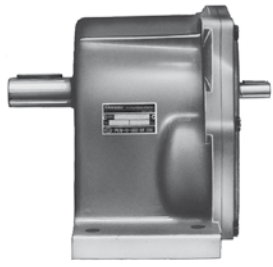

R 2I 32, 40

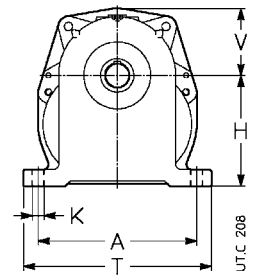

Standard design

Mounting position B3, B6, B7, B8, V5, V6

PC1A

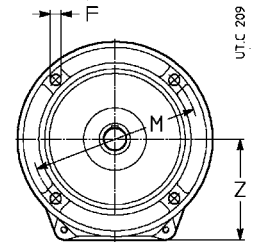
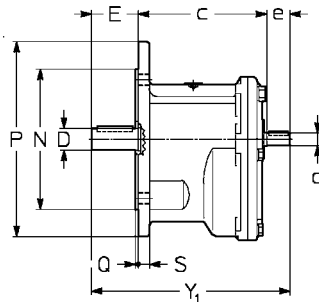

Standard design

Mounting position B5, V1, V3

FC1A

Size	A	B	C	c	D Ø	E	d	e	Y ₁	F Ø	H h11	K Ø	L	M Ø	N Ø h6	P Ø	Q	S	T	U	V	Z	Mass kg
32	115	53	20	103-93 ¹⁾	16	30	11	20	153	9,5	75	9,5	10	115	95	140	3	10	139	77	48 ²⁾	73	4
40	132	63	19	122	19	40	11	23	185	9,5	90	9,5	12	130	110	160	3,5	10	156	92	56	87	7

1) Dimensions of shaft end shoulder and flange surface respectively.
2) Square input flange \square 105: consult us if need be.

Mounting positions and grease quantities [kg]

Design	Mounting positions						Size	B3, B6 B7, B8	V5, V6
	B3	B6	B7	B8	V5	V6			
PC1A							32 40	0,14 0,26	0,25 0,47
FC1A							32 40	B5 0,1 0,19	V1, V3 0,18 0,35

U.T.C 216

Designs, dimensions, mounting positions and lubricant quantities 3.6

R 2l, 3l 50 ... 180

UT.C 626

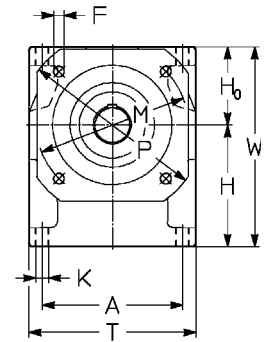
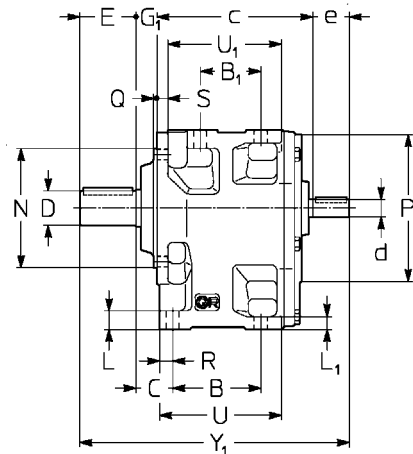

UC2A

Standard **design**

Mounting position B3, B6, B7, B8, V5, V6

Size	A	B	C	c	D	E	R2l		R3l		F	G ₁	H	H ₀	K	L	L ₁	M	N	P	P ₁	R	S	T	U	U ₁	W ₁	Mass kg				
							d	Y ₁	d	Y ₁																			d	Y ₁	d	Y ₁
50 51	124	76 52	30,5	138	24 28	50 42	14 30	234 226	14 30	234 226	11 23	227 219	11 23	227 219	9,5	16	106	71	11,5	17	12	130	110	160 3,5	140	13,5	10	148	110	100	177	12
63 64	153	96 66	36,5	168	32 38	58	19 40	285	16 30	275	14 30	275	14 30	275	11,5	19	132	85	14	20	14	165	130	200 3,5	160	16	12	182	136	124	217	20
80 81	192	123 87	43	208	38 48	80	24 50	360	19 40	350	19 40	350	16 30	340	14	22	160	106	16	24	17	215	180	250 4	200	19	14	226	171	157	266	35
100 101	240	160 119	51,5	253	48 55	82	28 60	422	24 50	412	24 50	412	19 40	402	14	27	195	132	18	28,5	20	265	230	300 4	250	22,5	16	280	214	198	327	62
125 126	297	200 151	59	311 ⁴⁾	60 70	105	32 80	526	32 80	526	28 60	502	24 50	492	18	30	236	160	22	35	25	300	250	350 5	300	26,5	19	345	264	245	396	110
140	297	218 169	59	329 ⁴⁾	80	130	32 80	569	32 80	569	28 60	545	24 50	535	18	30	250 ¹⁾	160 ¹⁾	22	35	25	300	250	350 5	300	26,5	19	345	282	263	410	123
160	373	250 191	68,5	385 ⁴⁾	90	130	42 110	659	42 110	659	32 80	623	32 80	623	22	34	295 ²⁾	200 ²⁾	27	42	30	400	350	450 5	400	31,5	22	430	326	304	495	195
180	373	275 216	68,5	410 ⁴⁾	100	165	42 110	719	42 110	719	32 80	683	32 80	683	22	34	315 ³⁾	200 ³⁾	27	42	30	400	350	450 5	400	31,5	22	430	351	329	515	260

- 1) For high speed shaft **H** dimension is -15 mm, **H₀** +15 mm.
- 2) For high speed shaft **H** dimension is -8 mm, **H₀** +8 mm.
- 3) For high speed shaft **H** dimension is -29 mm, **H₀** +29 mm.
- 4) For R 3l **c** dimension is -4 mm (sizes 125 ... 140), -6 mm (sizes 160 and 180).

Mounting positions and oil quantities [l]

Size	B3	B6	B7	B8	V5	V6	Size	B3	B6, B7	B8, V6	V5
							50, 51	0,8	1,1	1,1	1,4
							63, 64	1,6	2,2	2,2	2,8
							80, 81	3,1	4,3	4,3	5,5
							100, 101	5,6	7,1	8	10
							125, 126	10,2	13	14,6	18,3
							140	11,6	14,8	16,6	21
							160	19,6	25	28	35
							180	23	29	32	40

UT.C 626

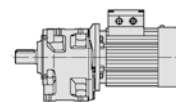

P_1 kW	n_2 min ⁻¹	M_2 daN m	f_s	Riduttore - Motore Gear reducer - Motor	i	P_1 kW	n_2 min ⁻¹	M_2 daN m	f_s	Riduttore - Motore Gear reducer - Motor	i		
1)				2)		1)				2)			
0,09	6,91	11,9	1,12	MR 3I 50 - 11 x 140 63 A	6	0,12	21,2	5,2	1,8	MR 3I 41 - 11 x 140 63 A	4		
	8,4	9,8	1,5	MR 3I 50 - 11 x 140 63 A	6		21,5	5,1	3,15	MR 3I 50 - 11 x 140 63 A	4		
	8,4	9,8	1,9	MR 3I 51 - 11 x 140 63 A	6		22,7	4,84	2	MR 3I 41 - 11 x 140 63 B	6		
	9,7	8,5	0,8	MR 3I 40 - 11 x 140 63 A	6		23,5	4,67	3,35	MR 3I 50 - 11 x 140 63 A	4		
	10,3	8	2	MR 3I 50 - 11 x 140 63 A	6		25	4,4	1,7	MR 3I 40 - 11 x 140 63 A	4		
	10,3	8	2,8	MR 3I 51 - 11 x 140 63 A	6		25	4,4	2,12	MR 3I 41 - 11 x 140 63 A	4		
	12,1	6,8	1,12	MR 3I 40 - 11 x 140 63 A	6		25,2	4,37	0,85	MR 3I 32 - 11 x 140 63 B	6		
	12,1	6,8	1,32	MR 3I 41 - 11 x 140 63 A	6		27,2	4,04	4	MR 3I 50 - 11 x 140 63 A	4		
	12,6	6,5	2,5	MR 3I 50 - 11 x 140 63 A	6		27,3	4,03	1,9	MR 3I 40 - 11 x 140 63 A	4		
	13,7	6	1,25	MR 3I 40 - 11 x 140 63 A	6		27,3	4,03	2,24	MR 3I 41 - 11 x 140 63 A	4		
	13,7	6	1,6	MR 3I 41 - 11 x 140 63 A	6		29,5	3,73	1	MR 3I 32 - 11 x 140 63 A	4		
	13,8	6	2,65	MR 3I 50 - 11 x 140 63 A	6		31,3	3,51	2,12	MR 3I 40 - 11 x 140 63 A	4		
	15,1	5,5	3	MR 3I 50 - 11 x 140 63 A	6		31,3	3,51	2,65	MR 3I 41 - 11 x 140 63 A	4		
	16,1	5,1	1,5	MR 3I 40 - 11 x 140 63 A	6		33,3	3,31	1,12	MR 3I 32 - 11 x 140 63 A	4		
	16,1	5,1	1,9	MR 3I 41 - 11 x 140 63 A	6		35,3	3,11	2,36	MR 3I 40 - 11 x 140 63 A	4		
	17,5	4,7	1,6	MR 3I 40 - 11 x 140 63 A	6		35,3	3,11	3	MR 3I 41 - 11 x 140 63 A	4		
	17,5	4,7	2	MR 3I 41 - 11 x 140 63 A	6		36,2	3,04	1,18	MR 3I 32 - 11 x 140 63 B	6		
	17,5	4,71	3,35	MR 3I 50 - 11 x 140 63 A	6		39,2	2,81	1,32	MR 3I 32 - 11 x 140 63 A	4		
	18,9	4,35	0,85	MR 3I 32 - 11 x 140 63 A	6		40,7	2,76	2,12	MR 2I 40 - 11 x 140 63 B	6		
	20,1	4,1	1,8	MR 3I 40 - 11 x 140 63 A	6		41,6	2,64	2,8	MR 3I 40 - 11 x 140 63 A	4		
	20,1	4,1	2,24	MR 3I 41 - 11 x 140 63 A	6		43,7	2,52	1,4	MR 3I 32 - 11 x 140 63 A	4		
	20,9	3,94	4	MR 3I 50 - 11 x 140 63 A	6		45,5	2,42	3	MR 3I 40 - 11 x 140 63 A	4		
	21,4	3,86	0,95	MR 3I 32 - 11 x 140 63 A	6		49,7	2,26	3	MR 2I 40 - 11 x 140 63 B	6		
	22,7	3,63	2,12	MR 3I 40 - 11 x 140 63 A	6		49,9	2,21	1,6	MR 3I 32 - 11 x 140 63 A	4		
	22,7	3,63	2,65	MR 3I 41 - 11 x 140 63 A	6		53,4	2,06	3,35	MR 3I 40 - 11 x 140 63 A	4		
	25,2	3,27	1,12	MR 3I 32 - 11 x 140 63 A	6		55,5	2,02	3,35	MR 2I 40 - 11 x 140 63 B	6		
	26,8	3,08	2,5	MR 3I 40 - 11 x 140 63 A	6		56,3	1,95	1,8	MR 3I 32 - 11 x 140 63 A	4		
	28,1	2,94	1,25	MR 3I 32 - 11 x 140 63 A	6		63,3	1,77	3,35	MR 2I 40 - 11 x 140 63 A	4		
	29,2	2,82	2,65	MR 3I 40 - 11 x 140 63 A	6		66,3	1,66	2,12	MR 3I 32 - 11 x 140 63 A	4		
	32,1	2,57	1,4	MR 3I 32 - 11 x 140 63 A	6		66,8	1,68	1,9	MR 2I 32 - 11 x 140 63 B	6		
	34,3	2,41	3	MR 3I 40 - 11 x 140 63 A	6		73,9	1,49	2,36	MR 3I 32 - 11 x 140 63 A	4		
	36,2	2,28	1,6	MR 3I 32 - 11 x 140 63 A	6		83,4	1,35	2,5	MR 2I 32 - 11 x 140 63 B	6		
	40,7	2,07	2,8	MR 2I 40 - 11 x 140 63 A	6		85	1,29	2,5	MR 3I 32 - 11 x 140 63 A	4		
	42,6	1,94	1,9	MR 3I 32 - 11 x 140 63 A	6		94,1	1,19	2,8	MR 2I 32 - 11 x 140 63 B	6		
	47,5	1,74	2,12	MR 3I 32 - 11 x 140 63 A	6		104	1,08	3	MR 2I 32 - 11 x 140 63 A	4		
	54,7	1,51	2,24	MR 3I 32 - 11 x 140 63 A	6		130	0,87	4	MR 2I 32 - 11 x 140 63 A	4		
	66,8	1,26	2,5	MR 2I 32 - 11 x 140 63 A	6		146	0,77	4,5	MR 2I 32 - 11 x 140 63 A	4		
	83,4	1,01	3,35	MR 2I 32 - 11 x 140 63 A	6		172	0,65	5,3	MR 2I 32 - 11 x 140 63 A	4		
	94,1	0,9	3,75	MR 2I 32 - 11 x 140 63 A	6		192	0,58	5,6	MR 2I 32 - 11 x 140 63 A	4		
	0,12	6,91	15,9	0,85	MR 3I 50 - 11 x 140 63 B		6	0,18	6,33	26,1	1,06	MR 3I 63 - 14 x 160 71 A	6
		8,4	13,1	1,12	MR 3I 50 - 11 x 140 63 B		6		8,09	20,4	1,5	MR 3I 63 - 14 x 160 71 A	6
		8,4	13,1	1,4	MR 3I 51 - 11 x 140 63 B		6		8,09	20,4	1,8	MR 3I 64 - 14 x 160 71 A	6
		10,3	10,7	1,5	MR 3I 50 - 11 x 140 63 B		6		10,1	16,3	2	MR 3I 63 - 14 x 160 71 A	6
		10,3	10,7	2	MR 3I 51 - 11 x 140 63 B		6		10,1	16,3	2,65	MR 3I 64 - 14 x 160 71 A	6
		10,7	10,2	1,32	MR 3I 50 - 11 x 140 63 A		4		10,7	15,4	0,85	MR 3I 50 - 11 x 140 63 B	4
12,1		9,1	0,8	MR 3I 40 - 11 x 140 63 B	6	11,6	14,2		1	MR 3I 50 - 14 x 160 71 A	6		
12,1		9,1	1	MR 3I 41 - 11 x 140 63 B	6	11,6	14,2		1,32	MR 3I 51 - 14 x 160 71 A	6		
13,1		8,4	1,7	MR 3I 50 - 11 x 140 63 A	4	12,1	13,7		2,5	MR 3I 63 - 14 x 160 71 A	6		
13,1		8,4	2,24	MR 3I 51 - 11 x 140 63 A	4	13,1	12,6		1,12	MR 3I 50 - 11 x 140 63 B	4		
13,7		8,1	0,95	MR 3I 40 - 11 x 140 63 B	6	13,1	12,6		1,5	MR 3I 51 - 11 x 140 63 B	4		
13,7		8,1	1,18	MR 3I 41 - 11 x 140 63 B	6	14,2	11,6		1,4	MR 3I 50 - 14 x 160 71 A	6		
13,8		7,9	2	MR 3I 50 - 11 x 140 63 B	6	14,2	11,6		1,9	MR 3I 51 - 14 x 160 71 A	6		
13,8		7,9	2,8	MR 3I 51 - 11 x 140 63 B	6	14,7	11,2		3	MR 3I 63 - 14 x 160 71 A	6		
15,1		7,3	0,95	MR 3I 40 - 11 x 140 63 A	4	16	10,3		1,6	MR 3I 50 - 11 x 140 63 B	4		
16		6,9	2,36	MR 3I 50 - 11 x 140 63 A	4	16	10,3		2,12	MR 3I 51 - 11 x 140 63 B	4		
16		6,9	3,15	MR 3I 51 - 11 x 140 63 A	4	16,7	9,9		0,95	MR 3I 41 - 14 x 160 71 A	6		
16,1		6,8	1,12	MR 3I 40 - 11 x 140 63 B	6	17,4	9,5		1,7	MR 3I 50 - 14 x 160 71 A	6		
16,1		6,8	1,4	MR 3I 41 - 11 x 140 63 B	6	17,4	9,5		2,24	MR 3I 51 - 14 x 160 71 A	6		
17,5		6,3	2,5	MR 3I 50 - 11 x 140 63 B	6	18,8	8,8		0,85	MR 3I 40 - 11 x 140 63 B	4		
18,8		5,8	1,32	MR 3I 40 - 11 x 140 63 A	4	18,8	8,8		1,06	MR 3I 41 - 11 x 140 63 B	4		
18,8		5,8	1,6	MR 3I 41 - 11 x 140 63 A	4	19,6	8,4		1,9	MR 3I 50 - 11 x 140 63 B	4		
19,6		5,6	2,8	MR 3I 50 - 11 x 140 63 A	4	19,6	8,4		2,65	MR 3I 51 - 11 x 140 63 B	4		
20,1		5,5	1,4	MR 3I 40 - 11 x 140 63 B	6	21,2	7,8		0,95	MR 3I 40 - 11 x 140 63 B	4		
20,1		5,5	1,7	MR 3I 41 - 11 x 140 63 B	6								
21,2		5,2	1,4	MR 3I 40 - 11 x 140 63 A	4								

1) Powers valid for continuous duty S1; **increase** possible for S2... S10 (ch. 2b) in which case P_2 and M_2 increase and f_s decreases proportionately.
 2) For complete designation when ordering, see ch. 3.

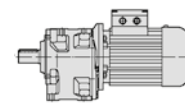

P_1 kW	n_2 min ⁻¹	M_2 daN m	f_s	Riduttore - Motore Gear reducer - Motor	i	
1)				2)		
0.18	21,2	7,8	1,25	MR 3I 41 - 11 x 140	63 B 4 65,9	
	21,5	7,7	2,12	MR 3I 50 - 11 x 140	63 B 4 65	
	21,5	7,7	3	MR 3I 51 - 11 x 140	63 B 4 65	
	23,5	7	2,24	MR 3I 50 - 11 x 140	63 B 4 59,5	
	25	6,6	1,12	MR 3I 40 - 11 x 140	63 B 4 55,9	
	25	6,6	1,4	MR 3I 41 - 11 x 140	63 B 4 55,9	
	27,2	6,1	2,65	MR 3I 50 - 11 x 140	63 B 4 51,4	
	27,3	6	1,25	MR 3I 40 - 11 x 140	63 B 4 51,3	
	27,3	6	1,5	MR 3I 41 - 11 x 140	63 B 4 51,3	
	31,3	5,3	1,4	MR 3I 40 - 11 x 140	63 B 4 44,7	
	31,3	5,3	1,7	MR 3I 41 - 11 x 140	63 B 4 44,7	
	32,5	5,1	3,15	MR 3I 50 - 11 x 140	63 B 4 43	
	35,3	4,67	1,6	MR 3I 40 - 11 x 140	63 B 4 39,6	
	35,3	4,67	2	MR 3I 41 - 11 x 140	63 B 4 39,6	
	35,7	4,62	3,35	MR 3I 50 - 11 x 140	63 B 4 39,2	
	39,1	4,22	3,75	MR 3I 50 - 11 x 140	63 B 4 35,8	
	39,2	4,21	0,85	MR 3I 32 - 11 x 140	63 B 4 35,7	
	41,6	3,96	1,9	MR 3I 40 - 11 x 140	63 B 4 33,6	
	41,6	3,96	2,36	MR 3I 41 - 11 x 140	63 B 4 33,6	
	43,7	3,78	0,9	MR 3I 32 - 11 x 140	63 B 4 32,1	
	45,5	3,63	2	MR 3I 40 - 11 x 140	63 B 4 30,8	
	45,5	3,63	2,5	MR 3I 41 - 11 x 140	63 B 4 30,8	
	49,9	3,31	1,06	MR 3I 32 - 11 x 140	63 B 4 28,1	
	53,4	3,09	2,24	MR 3I 40 - 11 x 140	63 B 4 26,2	
	53,4	3,09	2,65	MR 3I 41 - 11 x 140	63 B 4 26,2	
	55,6	3,03	1,9	MR 2I 40 - 14 x 160	71 A 6 16,2	
	56,3	2,93	1,18	MR 3I 32 - 11 x 140	63 B 4 24,9	
	63,3	2,66	2,12	MR 2I 40 - 11 x 140	63 B 4 22,1	
	66,3	2,49	1,4	MR 3I 32 - 11 x 140	63 B 4 21,1	
	67,7	2,49	2,65	MR 2I 40 - 14 x 160	71 A 6 13,3	
	73,9	2,23	1,6	MR 3I 32 - 11 x 140	63 B 4 18,9	
	77,3	2,18	3	MR 2I 40 - 11 x 140	63 B 4 18,1	
	85	1,94	1,7	MR 3I 32 - 11 x 140	63 B 4 16,5	
	86,3	1,95	3,35	MR 2I 40 - 11 x 140	63 B 4 16,2	
	96,6	1,74	4	MR 2I 40 - 11 x 140	63 B 4 14,5	
	104	1,62	1,9	MR 2I 32 - 11 x 140	63 B 4 13,5	
	109	1,54	4,5	MR 2I 40 - 11 x 140	63 B 4 12,8	
	130	1,3	2,65	MR 2I 32 - 11 x 140	63 B 4 10,8	
	146	1,15	3	MR 2I 32 - 11 x 140	63 B 4 9,57	
	172	0,98	3,35	MR 2I 32 - 11 x 140	63 B 4 8,12	
	192	0,88	3,75	MR 2I 32 - 11 x 140	63 B 4 7,29	
	221	0,76	4,5	MR 2I 32 - 11 x 140	63 B 4 6,33	
	277	0,61	4,5	MR 2I 32 - 11 x 140	63 B 4 5,06	
	0.25	8,09	28,3	1,06	MR 3I 63 - 14 x 160	71 B 6 111
		8,09	28,3	1,32	MR 3I 64 - 14 x 160	71 B 6 111
		9,85	23,3	1,18	MR 3I 63 - 14 x 160	71 A 4 142
		10,1	22,7	1,5	MR 3I 63 - 14 x 160	71 B 6 89
		10,1	22,7	1,9	MR 3I 64 - 14 x 160	71 B 6 89
11,6		19,8	0,95	MR 3I 51 - 14 x 160	71 B 6 77,7	
12,1		19	2,36	MR 3I 64 - 14 x 160	71 B 6 74,5	
12,6		18,2	1,7	MR 3I 63 - 14 x 160	71 A 4 111	
12,6		18,2	2	MR 3I 64 - 14 x 160	71 A 4 111	
13,1		17,6	0,85	MR 3I 50 - 11 x 140	63 C 4 107	
13,1		17,6	1,06	MR 3I 51 - 11 x 140	63 C 4 107	
14,2		16,1	1	MR 3I 50 - 14 x 160	71 B 6 63,2	
14,2		16,1	1,32	MR 3I 51 - 14 x 160	71 B 6 63,2	
14,7		15,6	2,12	MR 3I 63 - 14 x 160	71 B 6 61,3	
14,8		15,5	0,85	MR 3I 50 - 14 x 160	71 A 4 94,4	
15,7		14,6	2,24	MR 3I 63 - 14 x 160	71 A 4 89	
15,7		14,6	3	MR 3I 64 - 14 x 160	71 A 4 89	
16		14,3	1,12	MR 3I 50 - 11 x 140	63 C 4 87,3	
16		14,3	1,5	MR 3I 51 - 11 x 140	63 C 4 87,3	
17,4		13,2	1,7	MR 3I 51 - 14 x 160	71 B 6 51,7	
18		12,7	1,12	MR 3I 50 - 14 x 160	71 A 4 77,7	
18		12,7	1,5	MR 3I 51 - 14 x 160	71 A 4 77,7	

P_1 kW	n_2 min ⁻¹	M_2 daN m	f_s	Riduttore - Motore Gear reducer - Motor	i
1)				2)	
0,25	18,8	12,2	2,8	MR 3I 63 - 14 x 160	71 A 4 74,5
	19,4	11,8	2,8	MR 3I 63 - 14 x 160	71 B 6 46,3
	19,6	11,7	1,4	MR 3I 50 - 11 x 140	63 C 4 71,4
	19,6	11,7	1,9	MR 3I 51 - 11 x 140	63 C 4 71,4
	21,2	10,8	0,9	MR 3I 41 - 11 x 140	63 C 4 65,9
	21,5	10,6	1,5	MR 3I 50 - 11 x 140	63 C 4 65
	21,5	10,6	2,12	MR 3I 51 - 11 x 140	63 C 4 65
	22,1	10,4	1,5	MR 3I 50 - 14 x 160	71 A 4 63,2
	22,1	10,4	2,12	MR 3I 51 - 14 x 160	71 A 4 63,2
	22,8	10	3,35	MR 3I 63 - 14 x 160	71 A 4 61,3
	23,5	9,7	1,6	MR 3I 50 - 11 x 140	63 C 4 59,5
	23,5	9,7	2,36	MR 3I 51 - 11 x 140	63 C 4 59,5
	24,5	9,4	1,6	MR 3I 50 - 14 x 160	71 A 4 57,1
	24,5	9,4	2,24	MR 3I 51 - 14 x 160	71 A 4 57,1
	25	9,2	0,8	MR 3I 40 - 11 x 140	63 C 4 55,9
	25	9,2	1,06	MR 3I 41 - 11 x 140	63 C 4 55,9
	25,3	9,1	3,75	MR 3I 63 - 14 x 160	71 A 4 55,4
	26	8,8	0,85	MR 3I 40 - 14 x 160	71 A 4 53,9
	26	8,8	1,06	MR 3I 41 - 14 x 160	71 A 4 53,9
	27,1	8,5	1,9	MR 3I 50 - 14 x 160	71 A 4 51,7
	27,1	8,5	2,5	MR 3I 51 - 14 x 160	71 A 4 51,7
	27,2	8,4	1,9	MR 3I 50 - 11 x 140	63 C 4 51,4
	27,2	8,4	2,65	MR 3I 51 - 11 x 140	63 C 4 51,4
	27,3	8,4	0,9	MR 3I 40 - 11 x 140	63 C 4 51,3
	27,3	8,4	1,06	MR 3I 41 - 11 x 140	63 C 4 51,3
	29,3	7,8	0,95	MR 3I 40 - 14 x 160	71 A 4 47,7
	29,3	7,8	1,18	MR 3I 41 - 14 x 160	71 A 4 47,7
	29,7	7,7	2	MR 3I 50 - 14 x 160	71 A 4 47,1
	29,7	7,7	2,8	MR 3I 51 - 14 x 160	71 A 4 47,1
	31,3	7,3	1	MR 3I 40 - 11 x 140	63 C 4 44,7
	31,3	7,3	1,25	MR 3I 41 - 11 x 140	63 C 4 44,7
	32,5	7	2,24	MR 3I 50 - 11 x 140	63 C 4 43
	32,5	7,1	2,24	MR 3I 50 - 14 x 160	71 A 4 43,1
	32,5	7,1	3,15	MR 3I 51 - 14 x 160	71 A 4 43,1
	34,6	6,6	1,12	MR 3I 40 - 14 x 160	71 A 4 40,5
	34,6	6,6	1,4	MR 3I 41 - 14 x 160	71 A 4 40,5
	35,3	6,5	1,12	MR 3I 40 - 11 x 140	63 C 4 39,6
	35,3	6,5	1,4	MR 3I 41 - 11 x 140	63 C 4 39,6
	35,7	6,4	2,5	MR 3I 50 - 11 x 140	63 C 4 39,2
	37,6	6,1	2,65	MR 3I 50 - 14 x 160	71 A 4 37,2
	37,7	6,1	1,25	MR 3I 40 - 14 x 160	71 A 4 37,1
	37,7	6,1	1,5	MR 3I 41 - 14 x 160	71 A 4 37,1
	39,1	5,9	2,65	MR 3I 50 - 11 x 140	63 C 4 35,8
	40,4	5,8	2,24	MR 2I 50 - 14 x 160	71 B 6 22,3
	41,6	5,5	1,32	MR 3I 40 - 11 x 140	63 C 4 33,6
	41,6	5,5	1,7	MR 3I 41 - 11 x 140	63 C 4 33,6
	43,2	5,3	1,32	MR 3I 40 - 14 x 160	71 A 4 32,4
	43,2	5,3	1,7	MR 3I 41 - 14 x 160	71 A 4 32,4
	44,9	5,1	3	MR 3I 50 - 14 x 160	71 A 4 31,2
	45,2	5,1	3,15	MR 3I 50 - 11 x 140	63 C 4 31
	45,5	5	1,5	MR 3I 40 - 11 x 140	63 C 4 30,8
	45,5	5	1,8	MR 3I 41 - 11 x 140	63 C 4 30,8
	48,8	4,7	1,5	MR 3I 40 - 14 x 160	71 A 4 28,7
	48,8	4,7	1,9	MR 3I 41 - 14 x 160	71 A 4 28,7
	49,3	4,65	3,35	MR 3I 50 - 14 x 160	71 A 4 28,4
	49,9	4,6	0,8	MR 3I 32 - 11 x 140	63 C 4 28,1
	53,4	4,3	1,6	MR 3I 40 - 11 x 140	63 C 4 26,2
	53,4	4,3	1,9	MR 3I 41 - 11 x 140	63 C 4 26,2
	53,9	4,25	3,55	MR 3I 50 - 14 x 160	71 A 4 26
	55,6	4,21	1,4	MR 2I 40 - 14 x 160	71 B 6 16,2
	56,3	4,07	0,9	MR 3I 32 - 11 x 140	63 C 4 24,9
	57,5	3,99	1,8	MR 3I 40 - 14 x 160	71 A 4 24,4
	57,5	3,99	2,24	MR 3I 41 - 14 x 160	71 A 4 24,4
	62,4	3,67	4,25	MR 3I 50 - 14 x 160	71 A 4 22,4
	62,8	3,65	2	MR 3I 40 - 14 x 160	71 A 4 22,3
	62,8	3,65	2,5	MR 3I 41 - 14 x 160	71 A 4 22,3
	62,9	3,72	3,35	MR 2I 50 - 14 x 160	71 A 4 22,3
	63,3	3,69	1,6	MR 2I 40 - 11 x 140	63 C 4 22,1
66,3	3,46	1,06	MR 3I 32 - 11 x 140	63 C 4 21,1	
67,7	3,46	1,9	MR 2I 40 - 14 x 160	71 B 6 13,3	

1) Powers valid for continuous duty S1; **increase** possible for S2 ... S10 (ch. 2b) in which case P_2 and M_2 increase and f_s decreases proportionately.
 2) For complete designation when ordering, see ch. 3.

Gearmotors selection tables

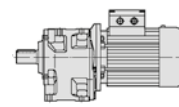

3.7

P_1 kW	n_2 min ⁻¹	M_2 daN m	f_s	Riduttore - Motore Gear reducer - Motor	i	
1)				2)		
0,25	67,7	3,46	2,12	MR 2I 41 - 14 x 160 71 B	6 13,3	
	73,7	3,11	2,12	MR 3I 40 - 14 x 160 71 A	4 19	
	73,7	3,11	2,65	MR 3I 41 - 14 x 160 71 A	4 19	
	73,9	3,1	1,18	MR 3I 32 - 11 x 140 63 C	4 18,9	
	76,6	3,06	2,24	MR 2I 40 - 14 x 160 71 B	6 11,8	
	76,6	3,06	2,65	MR 2I 41 - 14 x 160 71 B	6 11,8	
	77,3	3,02	2,12	MR 2I 40 - 11 x 140 63 C	4 18,1	
	85	2,7	1,18	MR 3I 32 - 11 x 140 63 C	4 16,5	
	86,3	2,71	2,5	MR 2I 40 - 11 x 140 63 C	4 16,2	
	86,3	2,71	3	MR 2I 41 - 11 x 140 63 C	4 16,2	
	86,4	2,71	2,12	MR 2I 40 - 14 x 160 71 A	4 16,2	
	92,2	2,49	2,12	MR 3I 40 - 14 x 160 71 A	4 15,2	
	96,6	2,42	2,8	MR 2I 40 - 11 x 140 63 C	4 14,5	
	104	2,25	1,4	MR 2I 32 - 11 x 140 63 C	4 13,5	
	105	2,22	2,8	MR 2I 40 - 14 x 160 71 A	4 13,3	
	109	2,14	3,15	MR 2I 40 - 11 x 140 63 C	4 12,8	
	119	1,96	3,35	MR 2I 40 - 14 x 160 71 A	4 11,8	
	128	1,82	3,75	MR 2I 40 - 11 x 140 63 C	4 10,9	
	130	1,8	1,9	MR 2I 32 - 11 x 140 63 C	4 10,8	
	133	1,77	3,75	MR 2I 40 - 14 x 160 71 A	4 10,6	
	146	1,6	2,12	MR 2I 32 - 11 x 140 63 C	4 9,57	
	149	1,57	4,25	MR 2I 40 - 14 x 160 71 A	4 9,41	
	172	1,36	2,5	MR 2I 32 - 11 x 140 63 C	4 8,12	
	175	1,33	5	MR 2I 40 - 14 x 160 71 A	4 7,98	
	191	1,22	5,6	MR 2I 40 - 14 x 160 71 A	4 7,32	
	192	1,22	2,8	MR 2I 32 - 11 x 140 63 C	4 7,29	
	221	1,06	3,15	MR 2I 32 - 11 x 140 63 C	4 6,33	
	277	0,85	3,35	MR 2I 32 - 11 x 140 63 C	4 5,06	
	345	0,68	4,75	MR 2I 32 - 11 x 140 63 B	2 8,12	
	384	0,61	5,3	MR 2I 32 - 11 x 140 63 B	2 7,29	
	442	0,53	6	MR 2I 32 - 11 x 140 63 B	2 6,33	
	554	0,42	6,3	MR 2I 32 - 11 x 140 63 B	2 5,06	
	0,37	5,84	58	0,95	MR 3I 80 - 19 x 200 80 A	6 154
		7,13	47,6	1,32	MR 3I 80 - 19 x 200 80 A	6 126
		7,13	47,6	1,6	MR 3I 81 - 19 x 200 80 A	6 126
		8,09	41,9	0,9	MR 3I 64 - 14 x 160 71 C	6 111
		8,9	38,1	1,8	MR 3I 80 - 19 x 200 80 A	6 101
		8,9	38,1	2,24	MR 3I 81 - 19 x 200 80 A	6 101
		9,85	34,4	0,8	MR 3I 63 - 14 x 160 71 B	4 142
		10,1	33,6	1	MR 3I 63 - 14 x 160 71 C	6 89
		10,1	33,6	1,32	MR 3I 64 - 14 x 160 71 C	6 89
		10,6	31,9	2,12	MR 3I 80 - 19 x 200 80 A	6 84,6
		10,6	31,9	2,8	MR 3I 81 - 19 x 200 80 A	6 84,6
		12,1	28,1	1,18	MR 3I 63 - 14 x 160 71 C	6 74,5
		12,1	28,1	1,6	MR 3I 64 - 14 x 160 71 C	6 74,5
		12,6	27	1,12	MR 3I 63 - 14 x 160 71 B	4 111
		12,6	27	1,4	MR 3I 64 - 14 x 160 71 B	4 111
		13,6	25	2,65	MR 3I 80 - 19 x 200 80 A	6 66,3
		14,2	23,8	0,9	MR 3I 51 - 14 x 160 71 C	6 63,2
		14,7	23,1	1,4	MR 3I 63 - 14 x 160 71 C	6 61,3
		14,7	23,1	1,9	MR 3I 64 - 14 x 160 71 C	6 61,3
		15,3	22,1	3	MR 3I 80 - 19 x 200 80 A	6 58,7
		15,7	21,6	1,6	MR 3I 63 - 14 x 160 71 B	4 89
15,7		21,6	2	MR 3I 64 - 14 x 160 71 B	4 89	
16,1		21,1	1	MR 3I 51 - 19 x 200 80 A	6 55,9	
17,8		19,1	0,85	MR 3I 50 - 19 x 200 80 A	6 50,6	
17,8		19,1	1,12	MR 3I 51 - 19 x 200 80 A	6 50,6	
18		18,8	0,8	MR 3I 50 - 14 x 160 71 B	4 77,7	
18		18,8	1	MR 3I 51 - 14 x 160 71 B	4 77,7	
18,8		18,1	1,9	MR 3I 63 - 14 x 160 71 B	4 74,5	
18,8		18,1	2,36	MR 3I 64 - 14 x 160 71 B	4 74,5	
19,4		17,5	2,36	MR 3I 64 - 14 x 160 71 C	6 46,3	
20,4		16,7	2	MR 3I 63 - 19 x 200 80 A	6 44,2	
20,9		16,2	1	MR 3I 50 - 14 x 160 71 C	6 43,1	
20,9		16,2	1,4	MR 3I 51 - 14 x 160 71 C	6 43,1	
22,1		15,3	1,06	MR 3I 50 - 14 x 160 71 B	4 63,2	

P_1 kW	n_2 min ⁻¹	M_2 daN m	f_s	Riduttore - Motore Gear reducer - Motor	i
1)				2)	
0,37	22,1	15,3	1,4	MR 3I 51 - 14 x 160 71 B	4 63,2
	22,8	14,9	2,24	MR 3I 63 - 14 x 160 71 B	4 61,3
	22,8	14,9	3	MR 3I 64 - 14 x 160 71 B	4 61,3
	24,5	13,8	1,12	MR 3I 50 - 14 x 160 71 B	4 57,1
	24,5	13,8	1,5	MR 3I 51 - 14 x 160 71 B	4 57,1
	25,3	13,4	2,5	MR 3I 63 - 14 x 160 71 B	4 55,4
	26,1	13	1,7	MR 3I 51 - 19 x 200 80 A	6 34,5
	27,1	12,5	1,25	MR 3I 50 - 14 x 160 71 B	4 51,7
	27,1	12,5	1,7	MR 3I 51 - 14 x 160 71 B	4 51,7
	27,8	12,2	2,8	MR 3I 63 - 14 x 160 71 B	4 50,4
	29,3	11,6	0,8	MR 3I 41 - 14 x 160 71 B	4 47,7
	29,7	11,4	1,4	MR 3I 50 - 14 x 160 71 B	4 47,1
	29,7	11,4	1,9	MR 3I 51 - 14 x 160 71 B	4 47,1
	30,2	11,2	2,8	MR 3I 63 - 14 x 160 71 B	4 46,3
	31,3	10,8	0,85	MR 3I 41 - 14 x 160 71 C	6 28,7
	32,5	10,4	1,5	MR 3I 50 - 14 x 160 71 B	4 43,1
	32,5	10,4	2,12	MR 3I 51 - 14 x 160 71 B	4 43,1
	33,7	10,1	3,15	MR 3I 63 - 14 x 160 71 B	4 41,6
	34,6	9,8	0,95	MR 3I 41 - 14 x 160 71 B	4 40,5
	34,7	9,8	1,6	MR 3I 50 - 14 x 160 71 C	6 26
	34,7	9,8	2,24	MR 3I 51 - 14 x 160 71 C	6 26
	37,3	9,1	3,55	MR 3I 63 - 14 x 160 71 B	4 37,6
	37,6	9	1,8	MR 3I 50 - 14 x 160 71 B	4 37,2
	37,6	9	2,5	MR 3I 51 - 14 x 160 71 B	4 37,2
	37,7	9	0,85	MR 3I 40 - 14 x 160 71 B	4 37,1
	37,7	9	1	MR 3I 41 - 14 x 160 71 B	4 37,1
	40,4	8,4	1,12	MR 3I 41 - 14 x 160 71 C	6 22,3
	40,4	8,6	1,5	MR 2I 50 - 14 x 160 71 C	6 22,3
	43,2	7,9	0,9	MR 3I 40 - 14 x 160 71 B	4 32,4
	43,2	7,9	1,12	MR 3I 41 - 14 x 160 71 B	4 32,4
	44,9	7,6	2	MR 3I 50 - 14 x 160 71 B	4 31,2
	44,9	7,6	2,8	MR 3I 51 - 14 x 160 71 B	4 31,2
	48,8	7	1,06	MR 3I 40 - 14 x 160 71 B	4 28,7
	48,8	7	1,32	MR 3I 41 - 14 x 160 71 B	4 28,7
	49,3	6,9	2,24	MR 3I 50 - 14 x 160 71 B	4 28,4
	49,3	6,9	3,15	MR 3I 51 - 14 x 160 71 B	4 28,4
	53,9	6,3	2,5	MR 3I 50 - 14 x 160 71 B	4 26
	57,5	5,9	1,18	MR 3I 40 - 14 x 160 71 B	4 24,4
	57,5	5,9	1,5	MR 3I 41 - 14 x 160 71 B	4 24,4
	62,4	5,4	2,8	MR 3I 50 - 14 x 160 71 B	4 22,4
	62,8	5,4	1,32	MR 3I 40 - 14 x 160 71 B	4 22,3
	62,8	5,4	1,7	MR 3I 41 - 14 x 160 71 B	4 22,3
	62,9	5,5	2,24	MR 2I 50 - 14 x 160 71 B	4 22,3
	67,7	5,1	1,25	MR 2I 40 - 14 x 160 71 C	6 13,3
	67,7	5,1	1,4	MR 2I 41 - 14 x 160 71 C	6 13,3
	69	4,92	3,15	MR 3I 50 - 14 x 160 71 B	4 20,3
	73,7	4,61	1,5	MR 3I 40 - 14 x 160 71 B	4 19
	73,7	4,61	1,7	MR 3I 41 - 14 x 160 71 B	4 19
	76,5	4,53	3	MR 2I 50 - 14 x 160 71 B	4 18,3
	76,6	4,52	1,5	MR 2I 40 - 14 x 160 71 C	6 11,8
	76,6	4,52	1,8	MR 2I 41 - 14 x 160 71 C	6 11,8
	85	4,07	3,55	MR 2I 50 - 14 x 160 71 B	4 16,5
	85,2	4,07	1,7	MR 2I 40 - 14 x 160 71 C	6 10,6
85,2	4,07	2,12	MR 2I 41 - 14 x 160 71 C	6 10,6	
86,4	4,01	1,4	MR 2I 40 - 14 x 160 71 B	4 16,2	
92,2	3,68	1,5	MR 3I 40 - 14 x 160 71 B	4 15,2	
93,9	3,69	4	MR 2I 50 - 14 x 160 71 B	4 14,9	
102	3,41	4	MR 2I 50 - 14 x 160 71 B	4 13,8	
104	3,33	0,95	MR 2I 32 - 11 x 140 71 B	* 4 13,5	
105	3,29	1,9	MR 2I 40 - 14 x 160 71 B	4 13,3	
105	3,29	2,12	MR 2I 41 - 14 x 160 71 B	4 13,3	
112	3,09	4,75	MR 2I 50 - 14 x 160 71 B	4 12,5	
119	2,91	2,24	MR 2I 40 - 14 x 160 71 B	4 11,8	
119	2,91	2,65	MR 2I 41 - 14 x 160 71 B	4 11,8	
130	2,67	1,25	MR 2I 32 - 11 x 140 71 B	* 4 10,8	
133	2,61	2,5	MR 2I 40 - 14 x 160 71 B	4 10,6	
146	2,37	1,4	MR 2I 32 - 11 x 140 71 B	* 4 9,57	
149	2,33	2,8	MR 2I 40 - 14 x 160 71 B	4 9,41	

1) Powers valid for continuous duty S1; Increase possible for S2 ... S10 (ch. 2b) in which case P_2 and M_2 increase and f_s decreases proportionately.

2) For complete designation when ordering, see ch. 3.

* Mounting position B5R (see table ch. 2b).

Gearmotors selection tables

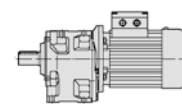

3.7

P_1 kW	n_2 min ⁻¹	M_2 daN m	f_s	Riduttore - Motore Gear reducer - Motor	i
1)	2)				
0,37	172	2,01	1,7	MR 2I 32 - 11 × 140 71 B *	4 8,12
	175	1,97	3,35	MR 2I 40 - 14 × 160 71 B	4 7,98
	191	1,81	3,75	MR 2I 40 - 14 × 160 71 B	4 7,32
	192	1,8	1,9	MR 2I 32 - 11 × 140 71 B *	4 7,29
	208	1,67	1,8	MR 2I 32 - 11 × 140 63 C	2 13,5
	221	1,57	2,12	MR 2I 32 - 11 × 140 71 B *	4 6,33
	225	1,54	4,25	MR 2I 40 - 14 × 160 71 B	4 6,22
	259	1,34	2,36	MR 2I 32 - 11 × 140 63 C	2 10,8
	277	1,25	2,24	MR 2I 32 - 11 × 140 71 B *	4 5,06
	282	1,23	4,5	MR 2I 40 - 14 × 160 71 B	4 4,97
	293	1,18	2,65	MR 2I 32 - 11 × 140 63 C	2 9,57
	345	1	3,15	MR 2I 32 - 11 × 140 63 C	2 8,12
	384	0,9	3,55	MR 2I 32 - 11 × 140 63 C	2 7,29
	442	0,78	4	MR 2I 32 - 11 × 140 63 C	2 6,33
	554	0,63	4,25	MR 2I 32 - 11 × 140 63 C	2 5,06
0,55	7,13	71	0,85	MR 3I 80 - 19 × 200 80 B	6 126
	7,13	71	1,06	MR 3I 81 - 19 × 200 80 B	6 126
	8,9	57	1,18	MR 3I 80 - 19 × 200 80 B	6 101
	8,9	57	1,5	MR 3I 81 - 19 × 200 80 B	6 101
	9,08	56	1	MR 3I 80 - 19 × 200 80 A	4 154
	10,6	47,4	1,4	MR 3I 80 - 19 × 200 80 B	6 84,6
	10,6	47,4	1,8	MR 3I 81 - 19 × 200 80 B	6 84,6
	11,1	45,4	1,32	MR 3I 80 - 19 × 200 80 A	4 126
	11,1	45,4	1,7	MR 3I 81 - 19 × 200 80 A	4 126
	12,1	41,7	0,9	MR 3I 64 - 19 × 200 80 B	6 74,3
	12,6	40,1	0,95	MR 3I 64 - 14 × 160 71 C	4 111
	13,8	36,4	1,8	MR 3I 80 - 19 × 200 80 A	4 101
	13,8	36,4	2,36	MR 3I 81 - 19 × 200 80 A	4 101
	14,7	34,2	0,8	MR 3I 63 - 19 × 200 80 A	4 94,9
	15,1	33,3	1	MR 3I 63 - 19 × 200 80 B	6 59,5
	15,1	33,3	1,32	MR 3I 64 - 19 × 200 80 B	6 59,5
	15,7	32,1	1,06	MR 3I 63 - 14 × 160 71 C	4 89
	15,7	32,1	1,4	MR 3I 64 - 14 × 160 71 C	4 89
	16,5	30,5	2,24	MR 3I 80 - 19 × 200 80 A	4 84,6
	16,5	30,5	2,8	MR 3I 81 - 19 × 200 80 A	4 84,6
	18,1	27,9	2,36	MR 3I 80 - 19 × 200 80 B	6 49,8
	18,4	27,4	1,6	MR 3I 64 - 19 × 200 80 B	6 48,9
	18,8	26,8	1,25	MR 3I 63 - 14 × 160 71 C	4 74,5
	18,8	26,8	1,12	MR 3I 63 - 19 × 200 80 A	4 74,3
	18,8	26,8	1,6	MR 3I 64 - 14 × 160 71 C	4 74,5
	18,8	26,8	1,4	MR 3I 64 - 19 × 200 80 A	4 74,3
	19,7	25,6	0,8	MR 3I 51 - 19 × 200 80 B	6 45,7
	20,4	24,8	1,32	MR 3I 63 - 19 × 200 80 B	6 44,2
	20,4	24,8	1,8	MR 3I 64 - 19 × 200 80 B	6 44,2
	21,1	23,9	2,8	MR 3I 80 - 19 × 200 80 A	4 66,3
	22,1	22,8	0,95	MR 3I 51 - 14 × 160 71 C	4 63,2
	22,5	22,4	0,85	MR 3I 51 - 19 × 200 80 A	4 62,2
	22,8	22,1	1,5	MR 3I 63 - 14 × 160 71 C	4 61,3
	22,8	22,1	2	MR 3I 64 - 14 × 160 71 C	4 61,3
	23,5	21,4	1,6	MR 3I 63 - 19 × 200 80 A	4 59,5
	23,5	21,4	2	MR 3I 64 - 19 × 200 80 A	4 59,5
	23,8	21,2	3,15	MR 3I 80 - 19 × 200 80 A	4 58,7
	23,9	21,1	1,06	MR 3I 51 - 19 × 200 80 B	6 37,7
	24,5	20,6	1	MR 3I 51 - 14 × 160 71 C	4 57,1
	25	20,1	1	MR 3I 51 - 19 × 200 80 A	4 55,9
	25,3	20	1,7	MR 3I 63 - 14 × 160 71 C	4 55,4
	25,3	20	2,24	MR 3I 64 - 14 × 160 71 C	4 55,4
	25,7	19,6	1,6	MR 3I 63 - 19 × 200 80 A	4 54,5
	25,7	19,6	2,12	MR 3I 64 - 19 × 200 80 A	4 54,5
	26,1	19,3	1,18	MR 3I 51 - 19 × 200 80 B	6 34,5
	27,1	18,6	0,85	MR 3I 50 - 14 × 160 71 C	4 51,7
	27,1	18,6	1,18	MR 3I 51 - 14 × 160 71 C	4 51,7
	27,6	18,2	0,85	MR 3I 50 - 19 × 200 80 A	4 50,6
	27,6	18,2	1,18	MR 3I 51 - 19 × 200 80 A	4 50,6
	27,8	18,1	1,8	MR 3I 63 - 14 × 160 71 C	4 50,4
	27,8	18,1	2,5	MR 3I 64 - 14 × 160 71 C	4 50,4
	28,6	17,6	1,9	MR 3I 63 - 19 × 200 80 A	4 48,9
	28,6	17,6	2,5	MR 3I 64 - 19 × 200 80 A	4 48,9

P_1 kW	n_2 min ⁻¹	M_2 daN m	f_s	Riduttore - Motore Gear reducer - Motor	i
1)	2)				
0,55	29,7	17	0,95	MR 3I 50 - 14 × 160 71 C	4 47,1
	29,7	17	1,32	MR 3I 51 - 14 × 160 71 C	4 47,1
	30,2	16,7	0,95	MR 3I 50 - 19 × 200 80 B	6 29,8
	30,2	16,7	1,32	MR 3I 51 - 19 × 200 80 B	6 29,8
	30,2	16,7	1,9	MR 3I 63 - 14 × 160 71 C	4 46,3
	30,2	16,7	2,36	MR 3I 64 - 14 × 160 71 C	4 46,3
	30,6	16,5	0,9	MR 3I 50 - 19 × 200 80 A	4 45,7
	30,6	16,5	1,25	MR 3I 51 - 19 × 200 80 A	4 45,7
	31,7	15,9	2,12	MR 3I 63 - 19 × 200 80 A	4 44,2
	31,7	15,9	2,8	MR 3I 64 - 19 × 200 80 A	4 44,2
	32,5	15,5	1	MR 3I 50 - 14 × 160 71 C	4 43,1
	32,5	15,5	1,4	MR 3I 51 - 14 × 160 71 C	4 43,1
	33,7	15	2,24	MR 3I 63 - 14 × 160 71 C	4 41,6
	33,7	15	2,8	MR 3I 64 - 14 × 160 71 C	4 41,6
	33,8	14,9	1,06	MR 3I 50 - 19 × 200 80 A	4 41,4
	33,8	14,9	1,4	MR 3I 51 - 19 × 200 80 A	4 41,4
	34,8	14,5	2,24	MR 3I 63 - 19 × 200 80 A	4 40,2
	34,8	14,5	3	MR 3I 64 - 19 × 200 80 A	4 40,2
	37,1	13,6	1,12	MR 3I 50 - 19 × 200 80 A	4 37,7
	37,1	13,6	1,6	MR 3I 51 - 19 × 200 80 A	4 37,7
	37,1	13,9	1,9	MR 2I 63 - 19 × 200 80 B	6 24,3
	37,3	13,5	2,36	MR 3I 63 - 14 × 160 71 C	4 37,6
	37,6	13,4	1,18	MR 3I 50 - 14 × 160 71 C	4 37,2
	37,6	13,4	1,7	MR 3I 51 - 14 × 160 71 C	4 37,2
	37,9	13,3	2,36	MR 3I 63 - 19 × 200 80 A	4 36,9
	40,4	12,7	1	MR 2I 50 - 14 × 160 80 B *	6 22,3
	40,6	12,4	1,25	MR 3I 50 - 19 × 200 80 A	4 34,5
	40,6	12,4	1,8	MR 3I 51 - 19 × 200 80 A	4 34,5
	41	12,3	2,65	MR 3I 63 - 14 × 160 71 C	4 34,2
	42,2	11,9	2,65	MR 3I 63 - 19 × 200 80 A	4 33,2
	43,3	11,6	1,32	MR 3I 50 - 19 × 200 80 B	6 20,8
	43,3	11,6	1,9	MR 3I 51 - 19 × 200 80 B	6 20,8
	44,9	11,2	1,4	MR 3I 50 - 14 × 160 71 C	4 31,2
	44,9	11,2	1,9	MR 3I 51 - 14 × 160 71 C	4 31,2
	46,7	10,8	3	MR 3I 63 - 19 × 200 80 A	4 30
	47	10,7	1,5	MR 3I 50 - 19 × 200 80 A	4 29,8
	47	10,7	2	MR 3I 51 - 19 × 200 80 A	4 29,8
	47,4	10,9	2,65	MR 2I 63 - 19 × 200 80 B	6 19
	48,8	10,3	0,9	MR 3I 41 - 14 × 160 71 C	4 28,7
	49,2	10,5	1,32	MR 2I 50 - 14 × 160 80 B *	6 18,3
	49,2	10,5	1,7	MR 2I 51 - 14 × 160 80 B *	6 18,3
	49,3	10,2	1,5	MR 3I 50 - 14 × 160 71 C	4 28,4
	49,3	10,2	2,12	MR 3I 51 - 14 × 160 71 C	4 28,4
	50,1	10,1	1,5	MR 3I 50 - 19 × 200 80 B	6 18
	50,1	10,1	2,12	MR 3I 51 - 19 × 200 80 B	6 18
	53,9	9,3	1,6	MR 3I 50 - 14 × 160 71 C	4 26
	53,9	9,3	2,36	MR 3I 51 - 14 × 160 71 C	4 26
	54,7	9,4	1,5	MR 2I 50 - 14 × 160 80 B *	6 16,5
	54,7	9,4	2,12	MR 2I 51 - 14 × 160 80 B *	6 16,5
	56,1	9	1,7	MR 3I 50 - 19 × 200 80 A	4 25
	56,1	9	2,36	MR 3I 51 - 19 × 200 80 A	4 25
	57,5	8,8	0,8	MR 3I 40 - 14 × 160 71 C	4 24,4
	57,5	8,8	1,06	MR 3I 41 - 14 × 160 71 C	4 24,4
	57,7	8,9	2,8	MR 2I 63 - 19 × 200 80 A	4 24,3
	60,4	8,5	1,8	MR 2I 50 - 14 × 160 80 B *	6 14,9
	60,4	8,5	2,36	MR 2I 51 - 14 × 160 80 B *	6 14,9
	60,5	8,5	1,5	MR 2I 50 - 19 × 200 80 B	6 14,9
	61,6	8,2	1,8	MR 3I 50 - 19 × 200 80 A	4 22,7
	61,6	8,2	2,65	MR 3I 51 - 19 × 200 80 A	4 22,7
	62,4	8,1	1,9	MR 3I 50 - 14 × 160 71 C	4 22,4
	62,4	8,1	2,65	MR 3I 51 - 14 × 160 71 C	4 22,4
	62,8	8	0,9	MR 3I 40 - 14 × 160 71 C	4 22,3
	62,8	8	1,12	MR 3I 41 - 14 × 160 71 C	4 22,3
	62,9	8,2	1,5	MR 2I 50 - 14 × 160 71 C	4 22,3
	65,3	7,9	1,8	MR 2I 50 - 14 × 160 80 B *	6 13,8
	65,3	7,9	2,5	MR 2I 51 - 14 × 160 80 B *	6 13,8
	67,4	7,5	2	MR 3I 50 - 19 × 200 80 A	4 20,8
	67,4	7,5	2,8	MR 3I 51 - 19 × 200 80 A	4 20,8
	67,7	7,6	0,85	MR 2I 40 - 14 × 160 80 B *	6 13,3
	67,7	7,6	0,95	MR 2I 41 - 14 × 160 80 B *	6 13,3
	69	7,3	2,12	MR 3I 50 - 14 × 160 71 C	4 20,3
	69	7,3	3	MR 3I 51 - 14 × 160 71 C	4 20,3

1) Powers valid for continuous duty S1; increase possible for S2 ... S10 (ch. 2b) in which case P_2 and M_2 increase and f_s decreases proportionately.

2) For complete designation when ordering, see ch. 3.

* Mounting position B5R (see table ch. 2b).

Gearmotors selection tables

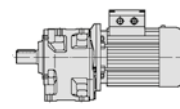

3.7

P_1 kW	n_2 min ⁻¹	M_2 daNm	f_s	Riduttore - Motore Gear reducer - Motor	i	P_1 kW	n_2 min ⁻¹	M_2 daNm	f_s	Riduttore - Motore Gear reducer - Motor	i				
1)				2)		1)				2)					
0,55	73.6	7	1,9	MR 21 50 - 19 x 200	80 B	6	12,2	0,75	9,36	73	1,8	MR 31 100 - 24 x 200	90 S	6	96,2
	73.6	7	2,5	MR 21 51 - 19 x 200	80 B	6	12,2		9,36	73	2,36	MR 31 101 - 24 x 200	90 S	6	96,2
	73.7	6,8	1	MR 31 40 - 14 x 160	71 C	4	19		11,1	62	1	MR 31 80 - 19 x 200	80 B	4	126
	73.7	6,8	1,18	MR 31 41 - 14 x 160	71 C	4	19		11,1	62	1,18	MR 31 81 - 19 x 200	80 B	4	126
	76.5	6,7	2	MR 21 50 - 14 x 160	71 C	4	18,3		11,5	60	2,24	MR 31 100 - 24 x 200	90 S	6	77,9
	76.5	6,7	2,65	MR 21 51 - 14 x 160	71 C	4	18,3		11,5	60	3	MR 31 101 - 24 x 200	90 S	6	77,9
	76.6	6,7	1	MR 21 40 - 14 x 160	80 B	* 6	11,8		13,8	49,6	1,32	MR 31 80 - 19 x 200	80 B	4	101
	76.6	6,7	1,18	MR 21 41 - 14 x 160	80 B	* 6	11,8		13,8	49,6	1,8	MR 31 81 - 19 x 200	80 B	4	101
	77.9	6,5	2,36	MR 31 50 - 19 x 200	80 A	4	18		14,1	48,7	2,65	MR 31 100 - 24 x 200	90 S	6	63,8
	77.9	6,5	3,35	MR 31 51 - 19 x 200	80 A	4	18		16,5	41,6	0,8	MR 31 63 - 19 x 200	80 C	6	54,5
	85	6,1	2,36	MR 21 50 - 14 x 160	71 C	4	16,5		16,5	41,6	1	MR 31 64 - 19 x 200	80 C	6	54,5
	85	6,1	3,15	MR 21 51 - 14 x 160	71 C	4	16,5		16,5	41,6	1,6	MR 31 80 - 19 x 200	80 B	4	84,6
	85.2	6	1,12	MR 21 40 - 14 x 160	80 B	* 6	10,6		16,5	41,6	2,12	MR 31 81 - 19 x 200	80 B	4	84,6
	85.2	6	1,4	MR 21 41 - 14 x 160	80 B	* 6	10,6		17	40,6	3,35	MR 31 100 - 24 x 200	90 S	6	53,1
	86.1	5,9	2,65	MR 31 50 - 19 x 200	80 A	4	16,3		18,1	38,1	1,8	MR 31 80 - 19 x 200	80 C	6	49,8
	86.4	6	0,95	MR 21 40 - 14 x 160	71 C	4	16,2		18,1	38,1	2,36	MR 31 81 - 19 x 200	80 C	6	49,8
	92.2	5,5	1	MR 31 40 - 14 x 160	71 C	4	15,2		18,4	37,4	1,18	MR 31 64 - 19 x 200	80 C	6	48,9
	93.9	5,5	2,65	MR 21 50 - 14 x 160	71 C	4	14,9		18,8	36,5	0,85	MR 31 63 - 19 x 200	80 B	4	74,3
	94.2	5,5	2,24	MR 21 50 - 19 x 200	80 A	4	14,9		18,8	36,5	1	MR 31 64 - 19 x 200	80 B	4	74,3
	95.6	5,4	1,6	MR 21 41 - 14 x 160	80 B	* 6	9,41		19,2	35,8	0,95	MR 31 63 - 24 x 200	90 S	6	46,9
	102	5,1	2,8	MR 21 50 - 14 x 160	71 C	4	13,8		19,2	35,8	1,25	MR 31 64 - 24 x 200	90 S	6	46,9
	105	4,89	1,32	MR 21 40 - 14 x 160	71 C	4	13,3		20,4	33,8	1	MR 31 63 - 19 x 200	80 C	6	44,2
	105	4,89	1,4	MR 21 41 - 14 x 160	71 C	4	13,3		20,4	33,8	1,32	MR 31 64 - 19 x 200	80 C	6	44,2
	112	4,59	3,15	MR 21 50 - 14 x 160	71 C	4	12,5		21,1	32,6	2	MR 31 80 - 19 x 200	80 B	4	66,3
	113	4,56	1,5	MR 21 40 - 14 x 160	80 B	* 6	7,98		21,1	32,6	2,65	MR 31 81 - 19 x 200	80 B	4	66,3
	113	4,56	1,9	MR 21 41 - 14 x 160	80 B	* 6	7,98		23,3	29,5	2,24	MR 31 80 - 19 x 200	80 C	6	38,6
	114	4,5	3	MR 21 50 - 19 x 200	80 A	4	12,2		23,5	29,2	1,12	MR 31 63 - 19 x 200	80 B	4	59,5
	119	4,32	1,5	MR 21 40 - 14 x 160	71 C	4	11,8		23,5	29,2	1,5	MR 31 64 - 19 x 200	80 B	4	59,5
	119	4,32	1,8	MR 21 41 - 14 x 160	71 C	4	11,8		23,8	28,9	2,36	MR 31 80 - 19 x 200	80 B	4	58,7
	123	4,19	2,12	MR 21 41 - 14 x 160	80 B	* 6	7,32		23,8	28,9	3,15	MR 31 81 - 19 x 200	80 B	4	58,7
	123	4,18	3,35	MR 21 50 - 14 x 160	71 C	4	11,4		25,7	26,8	1,18	MR 31 63 - 19 x 200	80 B	4	54,5
	127	4,04	3,35	MR 21 50 - 19 x 200	80 A	4	11		25,7	26,8	1,5	MR 31 64 - 19 x 200	80 B	4	54,5
	130	3,97	0,85	MR 21 32 - 11 x 140	71 C	* 4	10,8		25,8	26,6	1,7	MR 31 64 - 24 x 200	90 S	6	34,8
	133	3,88	1,7	MR 21 40 - 14 x 160	71 C	4	10,6		26,1	26,3	0,85	MR 31 51 - 19 x 200	80 C	6	34,5
	133	3,88	2,12	MR 21 41 - 14 x 160	71 C	4	10,6		27,6	24,9	0,85	MR 31 51 - 19 x 200	80 B	4	50,6
	135	3,82	3,75	MR 21 50 - 14 x 160	71 C	4	10,4		28,1	24,5	2,8	MR 31 80 - 19 x 200	80 B	4	49,8
	141	3,66	3,75	MR 21 50 - 19 x 200	80 A	4	9,96		28,6	24	1,4	MR 31 63 - 19 x 200	80 B	4	48,9
	146	3,52	0,95	MR 21 32 - 11 x 140	71 C	* 4	9,57		28,6	24	1,8	MR 31 64 - 19 x 200	80 B	4	48,9
	149	3,46	1,9	MR 21 40 - 14 x 160	71 C	4	9,41		29,7	23,1	0,95	MR 31 51 - 14 x 160	80 B	* 4	47,1
	149	3,46	2,5	MR 21 41 - 14 x 160	71 C	4	9,41		30,6	22,5	0,9	MR 31 51 - 19 x 200	80 B	4	45,7
	154	3,33	4,25	MR 21 50 - 19 x 200	80 A	4	9,07		31,7	21,7	1,5	MR 31 63 - 19 x 200	80 B	4	44,2
	172	2,98	1,12	MR 21 32 - 11 x 140	71 C	* 4	8,12		31,7	21,7	2	MR 31 64 - 19 x 200	80 B	4	44,2
	175	2,93	2,24	MR 21 40 - 14 x 160	71 C	4	7,98		32,1	21,4	3	MR 31 80 - 19 x 200	80 B	4	43,6
	175	2,93	2,8	MR 21 41 - 14 x 160	71 C	4	7,98		32,5	21,2	1,06	MR 31 51 - 14 x 160	80 B	* 4	43,1
	191	2,69	2,5	MR 21 40 - 14 x 160	71 C	4	7,32		33,8	20,3	1,06	MR 31 51 - 19 x 200	80 B	4	41,4
	191	2,69	3,15	MR 21 41 - 14 x 160	71 C	4	7,32		34,8	19,7	1,7	MR 31 63 - 19 x 200	80 B	4	40,2
	192	2,68	1,25	MR 21 32 - 11 x 140	71 C	* 4	7,29		34,8	19,7	2,24	MR 31 64 - 19 x 200	80 B	4	40,2
	208	2,48	1,25	MR 21 32 - 11 x 140	71 B	* 2	13,5		37,1	18,5	0,85	MR 31 50 - 19 x 200	80 B	4	37,7
	221	2,33	1,4	MR 21 32 - 11 x 140	71 C	* 4	6,33		37,1	18,5	1,18	MR 31 51 - 19 x 200	80 B	4	37,7
	225	2,29	3	MR 21 40 - 14 x 160	71 C	4	6,22		37,9	18,1	1,7	MR 31 63 - 19 x 200	80 B	4	36,9
259	1,98	1,6	MR 21 32 - 11 x 140	71 B	* 2	10,8	37,9	18,1	2,24	MR 31 64 - 19 x 200	80 B	4	36,9		
277	1,86	1,5	MR 21 32 - 11 x 140	71 C	* 4	5,06	40,6	16,9	0,9	MR 31 50 - 19 x 200	80 B	4	34,5		
282	1,83	3	MR 21 40 - 14 x 160	71 C	4	4,97	40,6	16,9	1,32	MR 31 51 - 19 x 200	80 B	4	34,5		
293	1,76	1,8	MR 21 32 - 11 x 140	71 B	* 2	9,57	42,2	16,3	2	MR 31 63 - 19 x 200	80 B	4	33,2		
345	1,49	2,12	MR 21 32 - 11 x 140	71 B	* 2	8,12	42,2	16,3	2,65	MR 31 64 - 19 x 200	80 B	4	33,2		
351	1,47	4,25	MR 21 40 - 14 x 160	71 B	2	7,98	46,7	14,7	2,24	MR 31 63 - 19 x 200	80 B	4	30		
383	1,35	4,75	MR 21 40 - 14 x 160	71 B	2	7,32	46,7	14,7	3	MR 31 64 - 19 x 200	80 B	4	30		
384	1,34	2,36	MR 21 32 - 11 x 140	71 B	* 2	7,29	47	14,6	1,06	MR 31 50 - 19 x 200	80 B	4	29,8		
442	1,16	2,8	MR 21 32 - 11 x 140	71 B	* 2	6,33	47	14,6	1,5	MR 31 51 - 19 x 200	80 B	4	29,8		
450	1,14	5,6	MR 21 40 - 14 x 160	71 B	2	6,22	49,3	13,9	1,12	MR 31 50 - 14 x 160	80 B	* 4	28,4		
554	0,93	2,8	MR 21 32 - 11 x 140	71 B	* 2	5,06	49,3	13,9	1,5	MR 31 51 - 14 x 160	80 B	* 4	28,4		
563	0,91	6	MR 21 40 - 14 x 160	71 B	2	4,97	51,4	13,4	2,36	MR 31 63 - 19 x 200	80 B	4	27,2		
							51,4	13,4	3,15	MR 31 64 - 19 x 200	80 B	4	27,2		
0,75	6.27	110	1	MR 31 100 - 24 x 200	90 S	6	144	56,1	12,3	1,25	MR 31 50 - 19 x 200	80 B	4	25	
	7.13	96	0,8	MR 31 81 - 19 x 200	80 C	6	126	56,1	12,3	1,7	MR 31 51 - 19 x 200	80 B	4	25	
	7.62	90	1,32	MR 31 100 - 24 x 200	90 S	6	118	57,7	12,2	2,12	MR 21 63 - 19 x 200	80 B	4	24,3	
	7.62	90	1,7	MR 31 101 - 24 x 200	90 S	6	118	60	11,5	2,8	MR 31 63 - 19 x 200	80 B	4	23,3	
	8.9	77	0,85	MR 31 80 - 19 x 200	80 C	6	101	60,5	11,6	1,06	MR 21 50 - 19 x 200	80 C	6	14,9	
	8.9	77	1,12	MR 31 81 - 19 x 200	80 C	6	101	61,6	11,2	1,32	MR 31 50 - 19 x 200	80 B	4	22,7	
								61,6	11,2	1,9	MR 31 51 - 19 x 200	80 B	4	22,7	

Motor (cat. TX) with efficiency value not according to IE3 class (IEC 60034-30); the nominal power and nameplate data refer to intermittent duty S3 70%.

1) Powers valid for continuous duty S1; **increase** possible for S2 ... S10 (ch. 2b) in which case P_2 and M_2 increase and f_s decreases proportionately.

2) For complete designation when ordering, see ch. 3.

* Mounting position **B5R** (see table ch. 2b).

Gearmotors selection tables

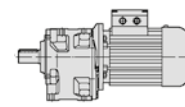

3.7

P_1 kW	n_2 min ⁻¹	M_2 daN m	f_s	Riduttore - Motore Gear reducer - Motor	i
0,75	66,7	10,3	3,15	MR 3I 63 - 19 x 200 80 B	4 21
	67,4	10,2	1,5	MR 3I 50 - 19 x 200 80 B	4 20,8
	67,4	10,2	2,12	MR 3I 51 - 19 x 200 80 B	4 20,8
	73,6	9,5	1,4	MR 2I 50 - 19 x 200 80 C	6 12,2
	73,6	9,5	1,9	MR 2I 51 - 19 x 200 80 C	6 12,2
	73,7	9,5	3	MR 2I 63 - 19 x 200 80 B	4 19
	76,8	9,1	1,32	MR 2I 50 - 24 x 200 90 S	6 11,7
	77,9	8,8	1,7	MR 3I 50 - 19 x 200 80 B	4 18
	77,9	8,8	2,36	MR 3I 51 - 19 x 200 80 B	4 18
	81,8	8,6	1,6	MR 2I 50 - 19 x 200 80 C	6 11
	81,8	8,6	2,24	MR 2I 51 - 19 x 200 80 C	6 11
	82,7	8,5	3,55	MR 2I 63 - 19 x 200 80 B	4 16,9
	85,2	8,2	0,85	MR 2I 41 - 19 x 160 80 C	** 6 10,6
	86,1	8	1,9	MR 3I 50 - 19 x 200 80 B	4 16,3
	86,1	8	2,65	MR 3I 51 - 19 x 200 80 B	4 16,3
	90,4	7,8	1,9	MR 2I 50 - 19 x 200 80 C	6 9,96
	93,4	7,5	1,8	MR 2I 50 - 24 x 200 90 S	6 9,64
	93,4	7,5	2,36	MR 2I 51 - 24 x 200 90 S	6 9,64
	94,2	7,5	1,6	MR 2I 50 - 19 x 200 80 B	4 14,9
	99,3	7,1	2,12	MR 2I 50 - 19 x 200 80 C	6 9,07
	99,3	7,1	3	MR 2I 51 - 19 x 200 80 C	6 9,07
	104	6,8	2	MR 2I 50 - 24 x 200 90 S	6 8,67
	104	6,8	2,8	MR 2I 51 - 24 x 200 90 S	6 8,67
	105	6,7	0,95	MR 2I 40 - 14 x 160 80 B	* 4 13,3
	105	6,7	1,06	MR 2I 41 - 14 x 160 80 B	* 4 13,3
	106	6,6	1,06	MR 2I 40 - 19 x 160 80 C	** 6 8,46
	106	6,6	1,25	MR 2I 41 - 19 x 160 80 C	** 6 8,46
	108	6,5	0,85	MR 2I 40 - 19 x 160 80 B	** 4 12,9
	114	6,1	2,12	MR 2I 50 - 19 x 200 80 B	4 12,2
	114	6,1	2,8	MR 2I 51 - 19 x 200 80 B	4 12,2
	119	5,9	1,12	MR 2I 40 - 14 x 160 80 B	* 4 11,8
	119	5,9	1,32	MR 2I 41 - 14 x 160 80 B	* 4 11,8
	120	5,8	1,5	MR 2I 41 - 19 x 160 80 C	** 6 7,5
	127	5,5	2,5	MR 2I 50 - 19 x 200 80 B	4 11
	133	5,3	1,25	MR 2I 40 - 14 x 160 80 B	* 4 10,6
	133	5,3	1,18	MR 2I 40 - 19 x 160 80 B	** 4 10,6
	133	5,3	1,6	MR 2I 41 - 14 x 160 80 B	* 4 10,6
	133	5,3	1,32	MR 2I 41 - 19 x 160 80 B	** 4 10,6
	141	4,99	2,8	MR 2I 50 - 19 x 200 80 B	4 9,96
	149	4,72	1,4	MR 2I 40 - 14 x 160 80 B	* 4 9,41
	149	4,72	1,4	MR 2I 40 - 19 x 160 80 B	** 4 9,41
	149	4,72	1,8	MR 2I 41 - 14 x 160 80 B	* 4 9,41
	149	4,72	1,6	MR 2I 41 - 19 x 160 80 B	** 4 9,41
	154	4,55	3,15	MR 2I 50 - 19 x 200 80 B	4 9,07
	165	4,24	1,6	MR 2I 40 - 19 x 160 80 B	** 4 8,46
	165	4,24	1,9	MR 2I 41 - 19 x 160 80 B	** 4 8,46
	169	4,16	3,35	MR 2I 50 - 19 x 200 80 B	4 8,29
	175	4	1,7	MR 2I 40 - 14 x 160 80 B	* 4 7,98
	175	4	2,12	MR 2I 41 - 14 x 160 80 B	* 4 7,98
	187	3,76	1,8	MR 2I 40 - 19 x 160 80 B	** 4 7,5
	187	3,76	2,24	MR 2I 41 - 19 x 160 80 B	** 4 7,5
	195	3,59	4	MR 2I 50 - 19 x 200 80 B	4 7,17
	216	3,25	4,25	MR 2I 50 - 19 x 200 80 B	4 6,49
	220	3,19	2,12	MR 2I 40 - 19 x 160 80 B	** 4 6,36
	220	3,19	2,65	MR 2I 41 - 19 x 160 80 B	** 4 6,36
	240	2,92	2,24	MR 2I 40 - 19 x 160 80 B	** 4 5,83
	240	2,92	2,8	MR 2I 41 - 19 x 160 80 B	** 4 5,83
	259	2,71	1,18	MR 2I 32 - 11 x 140 71 C	* 2 10,8
	282	2,49	2,65	MR 2I 40 - 19 x 160 80 B	** 4 4,96
	293	2,4	1,32	MR 2I 32 - 11 x 140 71 C	* 2 9,57
	345	2,04	1,6	MR 2I 32 - 11 x 140 71 C	* 2 8,12
	353	1,99	2,8	MR 2I 40 - 19 x 160 80 B	** 4 3,96
	383	1,84	3,55	MR 2I 40 - 14 x 160 71 C	* 2 7,32
	384	1,83	1,8	MR 2I 32 - 11 x 140 71 C	* 2 7,29
	442	1,59	2	MR 2I 32 - 11 x 140 71 C	* 2 6,33
	450	1,56	4	MR 2I 40 - 14 x 160 71 C	2 6,22
	554	1,27	2,12	MR 2I 32 - 11 x 140 71 C	* 2 5,06
	563	1,25	4,25	MR 2I 40 - 14 x 160 71 C	2 4,97

P_1 kW	n_2 min ⁻¹	M_2 daN m	f_s	Riduttore - Motore Gear reducer - Motor	i
1,1	7,62	132	0,9	MR 3I 100 - 24 x 200 90 L	6 118
	7,62	132	1,12	MR 3I 101 - 24 x 200 90 L	6 118
	9,36	108	1,25	MR 3I 100 - 24 x 200 90 L	6 96,2
	9,36	108	1,6	MR 3I 101 - 24 x 200 90 L	6 96,2
	9,75	103	1,06	MR 3I 100 - 24 x 200 90 S	4 144
	10,7	94	0,8	MR 3I 81 - 24 x 200 90 L	6 84,3
	11,1	91	0,85	MR 3I 81 - 19 x 200 80 C	4 126
	11,5	87	1,5	MR 3I 100 - 24 x 200 90 L	6 77,9
	11,5	87	2	MR 3I 101 - 24 x 200 90 L	6 77,9
	11,8	85	1,4	MR 3I 100 - 24 x 200 90 S	4 118
	11,8	85	1,8	MR 3I 101 - 24 x 200 90 S	4 118
	13,3	76	0,9	MR 3I 80 - 24 x 200 90 L	6 67,5
	13,3	76	1,18	MR 3I 81 - 24 x 200 90 L	6 67,5
	13,8	73	0,9	MR 3I 80 - 19 x 200 80 C	4 101
	13,8	73	1,18	MR 3I 81 - 19 x 200 80 C	4 101
	14,6	69	1,9	MR 3I 100 - 24 x 200 90 S	4 96,2
	14,6	69	2,5	MR 3I 101 - 24 x 200 90 S	4 96,2
	16,5	61	1,12	MR 3I 80 - 19 x 200 80 C	4 84,6
	16,5	61	1,4	MR 3I 81 - 19 x 200 80 C	4 84,6
	16,6	61	1	MR 3I 80 - 24 x 200 90 S	4 84,3
	16,6	61	1,25	MR 3I 81 - 24 x 200 90 S	4 84,3
	17	59	2,24	MR 3I 100 - 24 x 200 90 L	6 53,1
	17	59	1,12	MR 3I 80 - 24 x 200 90 L	6 52,9
	17	59	1,5	MR 3I 81 - 24 x 200 90 L	6 52,9
	18	56	2,36	MR 3I 100 - 24 x 200 90 S	4 77,9
	18	56	3,15	MR 3I 101 - 24 x 200 90 S	4 77,9
	19,2	53	0,85	MR 3I 64 - 24 x 200 90 L	6 46,9
	19,6	51	2,5	MR 3I 100 - 24 x 200 90 L	6 45,9
	20,7	48,6	1,4	MR 3I 80 - 24 x 200 90 S	4 67,5
	20,7	48,6	1,8	MR 3I 81 - 24 x 200 90 S	4 67,5
	21	48,1	0,85	MR 3I 64 - 24 x 200 90 L	6 42,9
	21,1	47,8	1,4	MR 3I 80 - 19 x 200 80 C	4 66,3
	21,1	47,8	1,8	MR 3I 81 - 19 x 200 80 C	4 66,3
	22	45,9	2,8	MR 3I 100 - 24 x 200 90 S	4 63,8
	22,6	44,6	1,5	MR 3I 80 - 24 x 200 90 L	6 39,8
	22,6	44,6	2	MR 3I 81 - 24 x 200 90 L	6 39,8
	23,3	43,2	1	MR 3I 64 - 24 x 200 90 L	6 38,5
	23,5	42,8	0,8	MR 3I 63 - 19 x 200 80 C	4 59,5
	23,5	42,8	1	MR 3I 64 - 19 x 200 80 C	4 59,5
	23,8	42,3	1,6	MR 3I 80 - 19 x 200 80 C	4 58,7
	23,8	42,4	1,5	MR 3I 80 - 24 x 200 90 S	4 58,8
	23,8	42,3	2,12	MR 3I 81 - 19 x 200 80 C	4 58,7
	23,8	42,4	1,9	MR 3I 81 - 24 x 200 90 S	4 58,8
	23,9	42,2	0,9	MR 3I 64 - 24 x 200 90 S	4 58,6
	24,1	41,8	3,15	MR 3I 100 - 24 x 200 90 S	4 58
	25,7	39,2	0,8	MR 3I 63 - 19 x 200 80 C	4 54,5
	25,7	39,2	1,06	MR 3I 64 - 19 x 200 80 C	4 54,5
	25,8	39	0,85	MR 3I 63 - 24 x 200 90 L	6 34,8
	25,8	39	1,18	MR 3I 64 - 24 x 200 90 L	6 34,8
	26,4	38,2	3,55	MR 3I 100 - 24 x 200 90 S	4 53,1
	26,5	38,1	1,7	MR 3I 80 - 24 x 200 90 S	4 52,9
	26,5	38,1	2,24	MR 3I 81 - 24 x 200 90 S	4 52,9
	26,8	37,6	0,85	MR 3I 63 - 24 x 200 90 S	4 52,2
	26,8	37,6	1,06	MR 3I 64 - 24 x 200 90 S	4 52,2
	28,1	35,9	1,9	MR 3I 80 - 19 x 200 80 C	4 49,8
	28,1	35,9	2,5	MR 3I 81 - 19 x 200 80 C	4 49,8
	28,4	35,5	0,95	MR 3I 63 - 24 x 200 90 L	6 31,7
	28,4	35,5	1,25	MR 3I 64 - 24 x 200 90 L	6 31,7
	28,6	35,2	0,95	MR 3I 63 - 19 x 200 80 C	4 48,9
	28,6	35,2	1,25	MR 3I 64 - 19 x 200 80 C	4 48,9
	29,9	33,8	1	MR 3I 63 - 24 x 200 90 S	4 46,9
	29,9	33,8	1,25	MR 3I 64 - 24 x 200 90 S	4 46,9
	29,9	33,8	2	MR 3I 80 - 24 x 200 90 S	4 46,9
	29,9	33,8	2,65	MR 3I 81 - 24 x 200 90 S	4 46,9
	31,7	31,9	1,06	MR 3I 63 - 19 x 200 80 C	4 44,2
	31,7	31,9	1,4	MR 3I 64 - 19 x 200 80 C	4 44,2
	32,1	31,4	2,12	MR 3I 80 - 19 x 200 80 C	4 43,6
	32,1	31,4	2,8	MR 3I 81 - 19 x 200 80 C	4 43,6
	32,6	30,9	1	MR 3I 63 - 24 x 200 90 S	4 42,9
	32,6	30,9	1,32	MR 3I 64 - 24 x 200 90 S	4 42,9

Motor (cat. TX) with efficiency value not according to IE3 class (IEC 60034-30); the nominal power and nameplate data refer to intermittent duty S3 70%.

1) Powers valid for continuous duty S1; increase possible for S2 ... S10 (ch. 2b) in which case P_2 and M_2 increase and f_s decreases proportionately.
2) For complete designation when ordering, see ch. 3.

* Mounting position **B5R** (see table ch. 2b).

** Mounting position **B5A** (see table ch. 2b).

Gearmotors selection tables

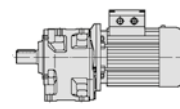

3.7

P_1 kW	n_2 min ⁻¹	M_2 daNm	f_s	Riduttore - Motore Gear reducer - Motor	i
1,1	34,8	28,9	1,12	MR 3I 63 - 19 x 200 80 C	4 40,2
	34,8	28,9	1,5	MR 3I 64 - 19 x 200 80 C	4 40,2
	35,2	28,6	2,36	MR 3I 80 - 24 x 200 90 S	4 39,8
	35,2	28,6	3,15	MR 3I 81 - 24 x 200 90 S	4 39,8
	36,3	27,8	1,18	MR 3I 63 - 24 x 200 90 S	4 38,5
	36,3	27,8	1,5	MR 3I 64 - 24 x 200 90 S	4 38,5
	36,3	27,8	2,36	MR 3I 80 - 19 x 200 80 C	4 38,6
	36,7	28	1,9	MR 2I 80 - 24 x 200 90 L	6 24,5
	37,1	27,2	0,8	MR 3I 51 - 19 x 200 80 C	4 37,7
	37,1	27,8	0,95	MR 2I 63 - 19 x 200 90 L	* 6 24,3
	37,9	26,6	1,18	MR 3I 63 - 19 x 200 80 C	4 36,9
	37,9	26,6	1,5	MR 3I 64 - 19 x 200 80 C	4 36,9
	40,2	25,1	1,32	MR 3I 63 - 24 x 200 90 S	4 34,8
	40,2	25,1	1,7	MR 3I 64 - 24 x 200 90 S	4 34,8
	40,3	25	2,65	MR 3I 80 - 24 x 200 90 S	4 34,8
	40,6	24,8	0,9	MR 3I 51 - 19 x 200 80 C	4 34,5
	42,2	23,9	1,32	MR 3I 63 - 19 x 200 80 C	4 33,2
	42,2	23,9	1,8	MR 3I 64 - 19 x 200 80 C	4 33,2
	42,7	23,6	2,8	MR 3I 80 - 19 x 200 80 C	4 32,8
	44,2	22,8	1,4	MR 3I 63 - 24 x 200 90 S	4 31,7
	44,2	22,8	1,9	MR 3I 64 - 24 x 200 90 S	4 31,7
	44,9	22,9	2,5	MR 2I 80 - 24 x 200 90 L	6 20,1
	45,5	22,2	3	MR 3I 80 - 24 x 200 90 S	4 30,8
	46,7	21,6	1,5	MR 3I 63 - 19 x 200 80 C	4 30
	46,7	21,6	2	MR 3I 64 - 19 x 200 80 C	4 30
	47	21,5	1	MR 3I 51 - 19 x 200 80 C	4 29,8
	47,4	21,7	1,32	MR 2I 63 - 19 x 200 90 L	* 6 19
	47,4	21,7	1,6	MR 2I 64 - 19 x 200 90 L	* 6 19
	48,1	21	1,5	MR 3I 63 - 24 x 200 90 S	4 29,1
	48,1	21	1,9	MR 3I 64 - 24 x 200 90 S	4 29,1
	51,4	19,6	1,6	MR 3I 63 - 19 x 200 80 C	4 27,2
	51,4	19,6	2,24	MR 3I 64 - 19 x 200 80 C	4 27,2
	53,6	18,8	1,7	MR 3I 63 - 24 x 200 90 S	4 26,1
	53,6	18,8	2,24	MR 3I 64 - 24 x 200 90 S	4 26,1
	55,5	18,5	1,4	MR 2I 63 - 24 x 200 90 L	6 16,2
	56,1	18	0,85	MR 3I 50 - 19 x 200 80 C	4 25
	56,1	18	1,18	MR 3I 51 - 19 x 200 80 C	4 25
	57,1	18	2,8	MR 2I 80 - 24 x 200 90 S	4 24,5
	57,7	17,8	1,4	MR 2I 63 - 19 x 200 80 C	4 24,3
	59,3	17	1,9	MR 3I 63 - 24 x 200 90 S	4 23,6
	59,3	17	2,5	MR 3I 64 - 24 x 200 90 S	4 23,6
	60	16,8	1,9	MR 3I 63 - 19 x 200 80 C	4 23,3
	60	16,8	2,65	MR 3I 64 - 19 x 200 80 C	4 23,3
	61,6	16,4	0,9	MR 3I 50 - 19 x 200 80 C	4 22,7
	61,6	16,4	1,32	MR 3I 51 - 19 x 200 80 C	4 22,7
	65,2	15,5	2	MR 3I 63 - 24 x 200 90 S	4 21,5
	65,2	15,5	2,8	MR 3I 64 - 24 x 200 90 S	4 21,5
	66,7	15,1	2,12	MR 3I 63 - 19 x 200 80 C	4 21
	66,7	15,1	2,8	MR 3I 64 - 19 x 200 80 C	4 21
	67,4	15	1	MR 3I 50 - 19 x 200 80 C	4 20,8
	67,4	15	1,4	MR 3I 51 - 19 x 200 80 C	4 20,8
	70,9	14,5	2	MR 2I 63 - 24 x 200 90 L	6 12,7
	70,9	14,5	2,36	MR 2I 64 - 24 x 200 90 L	6 12,7
	73,6	14	0,95	MR 2I 50 - 19 x 200 90 L	* 6 12,2
	73,6	14	1,25	MR 2I 51 - 19 x 200 90 L	* 6 12,2
	73,7	14	2	MR 2I 63 - 19 x 200 80 C	4 19
	73,7	14	2,5	MR 2I 64 - 19 x 200 80 C	4 19
	76,2	13,2	2,36	MR 3I 63 - 24 x 200 90 S	4 18,4
	76,8	13,4	0,9	MR 2I 50 - 24 x 200 90 L	6 11,7
	77,9	12,9	1,18	MR 3I 50 - 19 x 200 80 C	4 18
	77,9	12,9	1,6	MR 3I 51 - 19 x 200 80 C	4 18
	81,8	12,6	1,12	MR 2I 50 - 19 x 200 90 L	* 6 11
	81,8	12,6	1,5	MR 2I 51 - 19 x 200 90 L	* 6 11
	82,7	12,4	2,36	MR 2I 63 - 19 x 200 80 C	4 16,9
	84,7	11,9	2,65	MR 3I 63 - 24 x 200 90 S	4 16,5
	86,1	11,7	1,32	MR 3I 50 - 19 x 200 80 C	4 16,3
	86,1	11,7	1,8	MR 3I 51 - 19 x 200 80 C	4 16,3
	86,4	11,9	2,12	MR 2I 63 - 24 x 200 90 S	4 16,2
	88,6	11,6	2,65	MR 2I 63 - 24 x 200 90 L	6 10,2
	90,4	11,4	1,32	MR 2I 50 - 19 x 200 90 L	* 6 9,96
	90,4	11,4	1,8	MR 2I 51 - 19 x 200 90 L	* 6 9,96
	92,1	11,2	2,8	MR 2I 63 - 19 x 200 80 C	4 15,2

P_1 kW	n_2 min ⁻¹	M_2 daNm	f_s	Riduttore - Motore Gear reducer - Motor	i
1,1	93,4	11	1,18	MR 2I 50 - 24 x 200 90 L	6 9,64
	93,4	11	1,6	MR 2I 51 - 24 x 200 90 L	6 9,64
	94,2	10,9	1,12	MR 2I 50 - 19 x 200 80 C	4 14,9
	98,8	10,4	2,8	MR 2I 63 - 19 x 200 80 C	4 14,2
	104	9,9	1,4	MR 2I 50 - 24 x 200 90 L	6 8,67
	104	9,9	1,9	MR 2I 51 - 24 x 200 90 L	6 8,67
	110	9,4	3,15	MR 2I 63 - 19 x 200 80 C	4 12,7
	110	9,3	3	MR 2I 63 - 24 x 200 90 S	4 12,7
	114	9	1,5	MR 2I 50 - 19 x 200 80 C	4 12,2
	114	9	1,9	MR 2I 51 - 19 x 200 80 C	4 12,2
	115	9	1,6	MR 2I 50 - 24 x 200 90 L	6 7,85
	115	9	2,24	MR 2I 51 - 24 x 200 90 L	6 7,85
	120	8,6	1,4	MR 2I 50 - 24 x 200 90 S	4 11,7
	122	8,5	3,55	MR 2I 63 - 19 x 200 80 C	4 11,5
	124	8,3	3,55	MR 2I 63 - 24 x 200 90 S	4 11,3
	126	8,2	1,8	MR 2I 50 - 24 x 200 90 L	6 7,14
	126	8,2	2,5	MR 2I 51 - 24 x 200 90 L	6 7,14
	127	8,1	1,7	MR 2I 50 - 19 x 200 80 C	4 11
	127	8,1	2,24	MR 2I 51 - 19 x 200 80 C	4 11
	133	7,8	0,8	MR 2I 40 - 19 x 160 80 C	** 4 10,6
	133	7,8	0,9	MR 2I 41 - 19 x 160 80 C	** 4 10,6
	141	7,3	1,9	MR 2I 50 - 19 x 200 80 C	4 9,96
	141	7,3	2,65	MR 2I 51 - 19 x 200 80 C	4 9,96
	145	7,1	1,8	MR 2I 50 - 24 x 200 90 S	4 9,64
	145	7,1	2,36	MR 2I 51 - 24 x 200 90 S	4 9,64
	149	6,9	0,95	MR 2I 40 - 19 x 160 80 C	** 4 9,41
	149	6,9	1,12	MR 2I 41 - 19 x 160 80 C	** 4 9,41
	154	6,7	2,12	MR 2I 50 - 19 x 200 80 C	4 9,07
	154	6,7	3	MR 2I 51 - 19 x 200 80 C	4 9,07
	162	6,4	2,12	MR 2I 50 - 24 x 200 90 S	4 8,67
	162	6,4	2,8	MR 2I 51 - 24 x 200 90 S	4 8,67
	165	6,2	1,06	MR 2I 40 - 19 x 160 80 C	** 4 8,46
	165	6,2	1,32	MR 2I 41 - 19 x 160 80 C	** 4 8,46
	169	6,1	2,36	MR 2I 50 - 19 x 200 80 C	4 8,29
	178	5,8	2,36	MR 2I 50 - 24 x 200 90 S	4 7,85
	178	5,8	3,35	MR 2I 51 - 24 x 200 90 S	4 7,85
	187	5,5	1,18	MR 2I 40 - 19 x 160 80 C	** 4 7,5
	187	5,5	1,5	MR 2I 41 - 19 x 160 80 C	** 4 7,5
	195	5,3	2,65	MR 2I 50 - 19 x 200 80 C	4 7,17
	196	5,3	2,65	MR 2I 50 - 24 x 200 90 S	4 7,14
	214	4,8	2,8	MR 2I 50 - 24 x 200 90 S	4 6,53
	216	4,77	3	MR 2I 50 - 19 x 200 80 C	4 6,49
	220	4,68	1,4	MR 2I 40 - 19 x 160 80 C	** 4 6,36
	220	4,68	1,8	MR 2I 41 - 19 x 160 80 C	** 4 6,36
	240	4,29	1,5	MR 2I 40 - 19 x 160 80 C	** 4 5,83
	240	4,29	2	MR 2I 41 - 19 x 160 80 C	** 4 5,83
	248	4,15	3,35	MR 2I 50 - 24 x 200 90 S	4 5,65
	274	3,76	3,75	MR 2I 50 - 24 x 200 90 S	4 5,11
	282	3,65	1,8	MR 2I 40 - 19 x 160 80 C	** 4 4,96
	282	3,65	2,24	MR 2I 41 - 19 x 160 80 C	** 4 4,96
	342	3,01	3,75	MR 2I 50 - 24 x 200 90 S	4 4,1
	353	2,91	1,9	MR 2I 40 - 19 x 160 80 C	** 4 3,96
	374	2,76	2,24	MR 2I 40 - 19 x 160 80 B	** 2 7,5
	374	2,76	3	MR 2I 41 - 19 x 160 80 B	** 2 7,5
	440	2,34	2,65	MR 2I 40 - 19 x 160 80 B	** 2 6,36
	480	2,14	3	MR 2I 40 - 19 x 160 80 B	** 2 5,83
	564	1,82	3,55	MR 2I 40 - 19 x 160 80 B	** 2 4,96
	706	1,46	3,55	MR 2I 40 - 19 x 160 80 B	** 2 3,96
1,5	6,02	229	0,95	MR 3I 125 - 28 x 250 100 LA	6 150
	7,62	181	0,85	MR 3I 101 - 24 x 200 90 LC	6 118
	7,68	179	1,32	MR 3I 125 - 28 x 250 100 LA	6 117
	7,68	179	1,7	MR 3I 126 - 28 x 250 100 LA	6 117
	7,68	179	2,36	MR 3I 140 - 28 x 250 100 LA	6 117
	9,36	147	0,9	MR 3I 100 - 24 x 200 90 LC	6 96,2
	9,36	147	1,18	MR 3I 101 - 24 x 200 90 LC	6 96,2
	9,4	146	0,85	MR 3I 100 - 28 x 250 100 LA	6 95,7
	9,4	146	1	MR 3I 101 - 28 x 250 100 LA	6 95,7
	9,6	143	1,9	MR 3I 125 - 28 x 250 100 LA	6 93,7

Motor (cat. TX) with efficiency value not according to IE3 class (IEC 60034-30); the nominal power and nameplate data refer to intermittent duty S3 70%.

1) Powers valid for continuous duty S1; increase possible for S2 ... S10 (ch. 2b) in which case P_2 and M_2 increase and f_s decreases proportionately.

2) For complete designation when ordering, see ch. 3.

* Mounting position BSR (see table ch. 2b).

** Mounting position B5A (see table ch. 2b).

Gearmotors selection tables

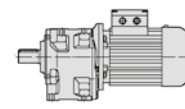

3.7

P_1 kW	n_2 min ⁻¹	M_2 daN m	f_s	Riduttore - Motore Gear reducer - Motor	i
1) 1,5	9,6	143	2,36	MR 3I 126 - 28 × 250 100 LA	6 93,7
	9,75	141	0,8	MR 3I 100 - 24 × 200 90 L	4 144
	11,5	119	1,12	MR 3I 100 - 28 × 250 100 LA	6 77,9
	11,5	119	1,12	MR 3I 100 - 24 × 200 90 LC	6 77,9
	11,5	119	1,5	MR 3I 101 - 28 × 250 100 LA	6 77,9
	11,5	119	1,5	MR 3I 101 - 24 × 200 90 LC	6 77,9
	11,8	116	1,06	MR 3I 100 - 24 × 200 90 L	4 118
	11,8	116	1,32	MR 3I 101 - 24 × 200 90 L	4 118
	12,1	114	2,36	MR 3I 125 - 28 × 250 100 LA	6 74,4
	12,1	114	3	MR 3I 126 - 28 × 250 100 LA	6 74,4
	13,3	103	0,85	MR 3I 81 - 24 × 200 90 LC	6 67,5
	14,6	94	1,4	MR 3I 100 - 24 × 200 90 L	4 96,2
	14,6	94	1,9	MR 3I 101 - 24 × 200 90 L	4 96,2
	14,7	93	2,8	MR 3I 125 - 28 × 250 100 LA	6 61,2
	15,8	87	1,5	MR 3I 100 - 28 × 250 100 LA	6 57,1
	15,8	87	1,9	MR 3I 101 - 28 × 250 100 LA	6 57,1
	16,3	84	3,15	MR 3I 125 - 28 × 250 100 LA	6 55,3
	16,6	83	0,9	MR 3I 81 - 24 × 200 90 L	4 84,3
	16,9	81	1,06	MR 3I 81 - 28 × 250 100 LA	6 53,2
	17	81	1,6	MR 3I 100 - 24 × 200 90 LC	6 53,1
	17	81	2,24	MR 3I 101 - 24 × 200 90 LC	6 53,1
	17	81	0,85	MR 3I 80 - 24 × 200 90 LC	6 52,9
	17	81	1,06	MR 3I 81 - 24 × 200 90 LC	6 52,9
	18	77	1,7	MR 3I 100 - 24 × 200 90 L	4 77,9
	18	77	2,24	MR 3I 101 - 24 × 200 90 L	4 77,9
	19,1	72	2,5	MR 3I 101 - 28 × 250 100 LA	6 47,1
	19,6	70	1,9	MR 3I 100 - 24 × 200 90 LC	6 45,9
	20,7	66	1	MR 3I 80 - 24 × 200 90 L	4 67,5
	20,7	66	1,32	MR 3I 81 - 24 × 200 90 L	4 67,5
	20,9	66	2	MR 3I 100 - 28 × 250 100 LA	6 43,1
	22	63	2,12	MR 3I 100 - 24 × 200 90 L	4 63,8
	22	63	2,8	MR 3I 101 - 24 × 200 90 L	4 63,8
	22,6	61	1,12	MR 3I 80 - 24 × 200 90 LC	6 39,8
	22,6	61	1,5	MR 3I 81 - 24 × 200 90 LC	6 39,8
	23,8	58	1,12	MR 3I 80 - 24 × 200 90 L	4 58,8
	23,8	58	1,4	MR 3I 81 - 24 × 200 90 L	4 58,8
	24,1	57	2,36	MR 3I 100 - 24 × 200 90 L	4 58
	25,8	53	0,85	MR 3I 64 - 24 × 200 90 LC	6 34,8
	26,4	52	2,5	MR 3I 100 - 24 × 200 90 L	4 53,1
	26,5	52	1,25	MR 3I 80 - 24 × 200 90 L	4 52,9
	26,5	52	1,7	MR 3I 81 - 24 × 200 90 L	4 52,9
	26,8	51	0,8	MR 3I 64 - 24 × 200 90 L	4 52,2
	28,1	48,9	2,65	MR 3I 100 - 24 × 200 90 LC	6 32
	28,9	47,6	2,8	MR 3I 100 - 28 × 250 100 LA	6 31,2
	29,9	46	0,95	MR 3I 64 - 24 × 200 90 L	4 46,9
	29,9	46	1,4	MR 3I 80 - 24 × 200 90 L	4 46,9
	29,9	46	1,9	MR 3I 81 - 24 × 200 90 L	4 46,9
	30,5	45,1	3	MR 3I 100 - 24 × 200 90 L	4 45,9
	32,6	42,2	0,95	MR 3I 64 - 24 × 200 90 L	4 42,9
	32,9	41,8	1,6	MR 3I 80 - 28 × 250 100 LA	6 27,4
	32,9	41,8	2	MR 3I 81 - 28 × 250 100 LA	6 27,4
	35,2	39,1	1,7	MR 3I 80 - 24 × 200 90 L	4 39,8
	35,2	39,1	2,24	MR 3I 81 - 24 × 200 90 L	4 39,8
	36,3	37,9	0,85	MR 3I 63 - 24 × 200 90 L	4 38,5
	36,3	37,9	1,12	MR 3I 64 - 24 × 200 90 L	4 38,5
	36,4	37,7	3,35	MR 3I 100 - 24 × 200 90 L	4 38,4
	40,2	34,2	0,95	MR 3I 63 - 24 × 200 90 L	4 34,8
	40,2	34,2	1,25	MR 3I 64 - 24 × 200 90 L	4 34,8
	40,3	34,1	1,9	MR 3I 80 - 24 × 200 90 L	4 34,8
	40,3	34,1	2,5	MR 3I 81 - 24 × 200 90 L	4 34,8
	44,2	31,1	1,06	MR 3I 63 - 24 × 200 90 L	4 31,7
	44,2	31,1	1,4	MR 3I 64 - 24 × 200 90 L	4 31,7
	45,5	30,3	2,12	MR 3I 80 - 24 × 200 90 L	4 30,8
	45,5	30,3	2,8	MR 3I 81 - 24 × 200 90 L	4 30,8
	48,1	28,6	1,06	MR 3I 63 - 24 × 200 90 L	4 29,1
	48,1	28,6	1,4	MR 3I 64 - 24 × 200 90 L	4 29,1
	48,7	28,2	2,36	MR 3I 80 - 28 × 250 100 LA	6 18,5
	49	28,1	1,18	MR 3I 63 - 24 × 200 90 LC	6 18,4
	49	28,1	1,6	MR 3I 64 - 24 × 200 90 LC	6 18,4
	50,3	27,9	2,24	MR 2I 80 - 24 × 200 90 LC	6 17,9

P_1 kW	n_2 min ⁻¹	M_2 daN m	f_s	Riduttore - Motore Gear reducer - Motor	i
1) 1,5	53,6	25,7	1,25	MR 3I 63 - 24 × 200 90 L	4 26,1
	53,6	25,7	1,6	MR 3I 64 - 24 × 200 90 L	4 26,1
	53,6	25,7	2,5	MR 3I 80 - 24 × 200 90 L	4 26,1
	56,1	24,5	0,85	MR 3I 51 - 19 × 200 90 L	* 4 25
	57,1	24,6	2,12	MR 2I 80 - 24 × 200 90 L	4 24,5
	57,7	24,3	1,06	MR 2I 63 - 19 × 200 90 L	* 4 24,3
	59,3	23,2	1,4	MR 3I 63 - 24 × 200 90 L	4 23,6
	59,3	23,2	1,8	MR 3I 64 - 24 × 200 90 L	4 23,6
	59,7	23	2,8	MR 3I 80 - 24 × 200 90 L	4 23,5
	61,6	22,3	0,95	MR 3I 51 - 19 × 200 90 L	* 4 22,7
	62,1	22,6	2,65	MR 2I 80 - 28 × 250 100 LA	6 14,5
	62,1	22,6	2,65	MR 2I 80 - 24 × 200 90 LC	6 14,5
	65,2	21,1	1,5	MR 3I 63 - 24 × 200 90 L	4 21,5
	65,2	21,1	2	MR 3I 64 - 24 × 200 90 L	4 21,5
	67,4	20,4	1,06	MR 3I 51 - 19 × 200 90 L	* 4 20,8
	69,8	20,1	2,8	MR 2I 80 - 24 × 200 90 L	4 20,1
	70,5	19,9	1,32	MR 2I 63 - 28 × 250 100 LA	6 12,8
	73,7	19,1	1,5	MR 2I 63 - 19 × 200 90 L	* 4 19
	73,7	19,1	1,8	MR 2I 64 - 19 × 200 90 L	* 4 19
	76,2	18	1,8	MR 3I 63 - 24 × 200 90 L	4 18,4
	76,2	18	2,36	MR 3I 64 - 24 × 200 90 L	4 18,4
	77,9	17,6	0,85	MR 3I 50 - 19 × 200 90 L	* 4 18
	77,9	17,6	1,18	MR 3I 51 - 19 × 200 90 L	* 4 18
	82,7	17	1,8	MR 2I 63 - 19 × 200 90 L	* 4 16,9
	82,7	17	2,24	MR 2I 64 - 19 × 200 90 L	* 4 16,9
	84,7	16,2	2	MR 3I 63 - 24 × 200 90 L	4 16,5
	84,7	16,2	2,65	MR 3I 64 - 24 × 200 90 L	4 16,5
	86,1	16	0,95	MR 3I 50 - 19 × 200 90 L	* 4 16,3
	86,1	16	1,32	MR 3I 51 - 19 × 200 90 L	* 4 16,3
	86,4	16,3	1,6	MR 2I 63 - 24 × 200 90 L	4 16,2
	90	15,6	2,24	MR 2I 64 - 28 × 250 100 LA	6 10
	92,1	15,2	2	MR 2I 63 - 19 × 200 90 L	* 4 15,2
	92,1	15,2	2,65	MR 2I 64 - 19 × 200 90 L	* 4 15,2
	93,4	15	0,9	MR 2I 50 - 24 × 200 90 LC	6 9,64
	93,4	15	1,18	MR 2I 51 - 24 × 200 90 LC	6 9,64
	94,2	14,9	0,8	MR 2I 50 - 19 × 200 90 L	* 4 14,9
	98,8	14,2	2,12	MR 2I 63 - 19 × 200 90 L	* 4 14,2
	98,8	14,2	2,65	MR 2I 64 - 19 × 200 90 L	* 4 14,2
	104	13,5	1	MR 2I 50 - 24 × 200 90 LC	6 8,67
	104	13,5	1,4	MR 2I 51 - 24 × 200 90 LC	6 8,67
	110	12,7	2,24	MR 2I 63 - 24 × 200 90 L	4 12,7
	110	12,7	2,65	MR 2I 64 - 24 × 200 90 L	4 12,7
	114	12,3	1,06	MR 2I 50 - 19 × 200 90 L	* 4 12,2
	114	12,3	1,4	MR 2I 51 - 19 × 200 90 L	* 4 12,2
	115	12,2	1,18	MR 2I 50 - 24 × 200 90 LC	6 7,85
	115	12,2	1,6	MR 2I 51 - 24 × 200 90 LC	6 7,85
	120	11,7	1,06	MR 2I 50 - 24 × 200 90 L	4 11,7
	124	11,3	2,5	MR 2I 63 - 24 × 200 90 L	4 11,3
	124	11,3	3,15	MR 2I 64 - 24 × 200 90 L	4 11,3
	127	11	1,25	MR 2I 50 - 19 × 200 90 L	* 4 11
	127	11	1,7	MR 2I 51 - 19 × 200 90 L	* 4 11
	138	10,2	3	MR 2I 63 - 24 × 200 90 L	4 10,2
	141	10	1,4	MR 2I 50 - 19 × 200 90 L	* 4 9,96
	141	10	2	MR 2I 51 - 19 × 200 90 L	* 4 9,96
	145	9,7	1,32	MR 2I 50 - 24 × 200 90 L	4 9,64
	145	9,7	1,8	MR 2I 51 - 24 × 200 90 L	4 9,64
	153	9,2	3,15	MR 2I 63 - 24 × 200 90 L	4 9,18
	154	9,1	1,6	MR 2I 50 - 19 × 200 90 L	* 4 9,07
	154	9,1	2,24	MR 2I 51 - 19 × 200 90 L	* 4 9,07
	162	8,7	1,6	MR 2I 50 - 24 × 200 90 L	4 8,67
	162	8,7	2,12	MR 2I 51 - 24 × 200 90 L	4 8,67
	168	8,4	3,55	MR 2I 63 - 24 × 200 90 L	4 8,34
	169	8,3	1,7	MR 2I 50 - 19 × 200 90 L	* 4 8,29
	169	8,3	2,36	MR 2I 51 - 19 × 200 90 L	* 4 8,29
	178	7,9	1,8	MR 2I 50 - 24 × 200 90 L	4 7,85
	178	7,9	2,5	MR 2I 51 - 24 × 200 90 L	4 7,85
	196	7,2	1,9	MR 2I 50 - 24 × 200 90 L	4 7,14
	196	7,2	2,8	MR 2I 51 - 24 × 200 90 L	4 7,14

Motor (cat. TX) with efficiency value not according to IE3 class (IEC 60034-30); the nominal power and nameplate data refer to intermittent duty S3 70%.

1) Powers valid for continuous duty S1; increase possible for S2 ... S10 (ch. 2b) in which case P_2 and M_2 increase and f_s decreases proportionately.

2) For complete designation when ordering, see ch. 3.a

* Mounting position BSR (see table ch. 2b).

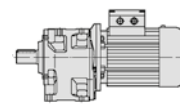

P_1 kW	n_2 min ⁻¹	M_2 daN m	f_s	Riduttore - Motore Gear reducer - Motor	i	
1)				2)		
1,5	211	6,7	0,9	MR 21 40 - 14 x 160 80 C * 2	13,3	
	211	6,7	1	MR 21 41 - 14 x 160 80 C * 2	13,3	
	214	6,6	2,12	MR 21 50 - 24 x 200 90 L 4	6,53	
	214	6,6	3	MR 21 51 - 24 x 200 90 L 4	6,53	
	238	5,9	1,06	MR 21 40 - 14 x 160 80 C * 2	11,8	
	238	5,9	1,25	MR 21 41 - 14 x 160 80 C * 2	11,8	
	248	5,7	2,5	MR 21 50 - 24 x 200 90 L 4	5,65	
	265	5,3	1,18	MR 21 40 - 14 x 160 80 C * 2	10,6	
	265	5,3	1,5	MR 21 41 - 14 x 160 80 C * 2	10,6	
	274	5,1	2,65	MR 21 50 - 24 x 200 90 L 4	5,11	
	298	4,72	1,32	MR 21 40 - 14 x 160 80 C * 2	9,41	
	298	4,72	1,7	MR 21 41 - 14 x 160 80 C * 2	9,41	
	331	4,24	1,5	MR 21 40 - 19 x 160 80 C ** 2	8,46	
	331	4,24	1,8	MR 21 41 - 19 x 160 80 C ** 2	8,46	
	342	4,11	2,8	MR 21 50 - 24 x 200 90 L 4	4,1	
	374	3,76	1,7	MR 21 40 - 19 x 160 80 C ** 2	7,5	
	374	3,76	2,12	MR 21 41 - 19 x 160 80 C ** 2	7,5	
	392	3,58	3,75	MR 21 50 - 24 x 200 90 S 2	7,14	
	429	3,28	4	MR 21 50 - 24 x 200 90 S 2	6,53	
	440	3,19	2	MR 21 40 - 19 x 160 80 C ** 2	6,36	
	440	3,19	2,5	MR 21 41 - 19 x 160 80 C ** 2	6,36	
	480	2,92	2,12	MR 21 40 - 19 x 160 80 C ** 2	5,83	
	480	2,92	2,8	MR 21 41 - 19 x 160 80 C ** 2	5,83	
	496	2,83	4,75	MR 21 50 - 24 x 200 90 S 2	5,65	
	548	2,56	5,3	MR 21 50 - 24 x 200 90 S 2	5,11	
	564	2,49	2,5	MR 21 40 - 19 x 160 80 C ** 2	4,96	
	564	2,49	3	MR 21 41 - 19 x 160 80 C ** 2	4,96	
	684	2,05	5,6	MR 21 50 - 24 x 200 90 S 2	4,1	
	706	1,99	2,65	MR 21 40 - 19 x 160 80 C ** 2	3,96	
	1,85	6,02	282	0,8	MR 31 125 - 28 x 250 100 LB 6	150
		7,68	221	1,12	MR 31 125 - 28 x 250 100 LB 6	117
		7,68	221	1,32	MR 31 126 - 28 x 250 100 LB 6	117
		7,68	221	1,9	MR 31 140 - 28 x 250 100 LB 6	117
		9,4	180	0,85	MR 31 101 - 28 x 250 100 LB 6	95,7
		9,42	180	2,65	MR 31 140 - 28 x 250 100 LB 6	95,5
		9,6	177	1,5	MR 31 125 - 28 x 250 100 LB 6	93,7
9,6		177	2	MR 31 126 - 28 x 250 100 LB 6	93,7	
11,5		147	0,9	MR 31 100 - 28 x 250 100 LB 6	77,9	
11,5		147	1,18	MR 31 101 - 28 x 250 100 LB 6	77,9	
11,8		143	0,85	MR 31 100 - 24 x 200 90 LB 4	118	
11,8		143	1,06	MR 31 101 - 24 x 200 90 LB 4	118	
12,1		140	1,9	MR 31 125 - 28 x 250 100 LB 6	74,4	
12,1		140	2,5	MR 31 126 - 28 x 250 100 LB 6	74,4	
14,6		117	1,12	MR 31 100 - 24 x 200 90 LB 4	96,2	
14,6		117	1,5	MR 31 101 - 24 x 200 90 LB 4	96,2	
14,7		115	2,24	MR 31 125 - 28 x 250 100 LB 6	61,2	
15,8		108	1,18	MR 31 100 - 28 x 250 100 LB 6	57,1	
15,8		108	1,5	MR 31 101 - 28 x 250 100 LB 6	57,1	
16,3		104	2,5	MR 31 125 - 28 x 250 100 LB 6	55,3	
16,9		100	0,85	MR 31 81 - 28 x 250 100 LB 6	53,2	
17,9		95	2,8	MR 31 125 - 28 x 250 100 LB 6	50,2	
18		94	1,4	MR 31 100 - 24 x 200 90 LB 4	77,9	
18		94	1,9	MR 31 101 - 24 x 200 90 LB 4	77,9	
20,7		82	0,8	MR 31 80 - 24 x 200 90 LB 4	67,5	
20,7		82	1,06	MR 31 81 - 24 x 200 90 LB 4	67,5	
20,9		81	1,6	MR 31 100 - 28 x 250 100 LB 6	43,1	
20,9		81	2,24	MR 31 101 - 28 x 250 100 LB 6	43,1	
21,6		79	0,85	MR 31 80 - 28 x 250 100 LB 6	41,7	
21,6		79	1,12	MR 31 81 - 28 x 250 100 LB 6	41,7	
22		77	1,7	MR 31 100 - 24 x 200 90 LB 4	63,8	
22		77	2,24	MR 31 101 - 24 x 200 90 LB 4	63,8	
23,8		71	0,9	MR 31 80 - 24 x 200 90 LB 4	58,8	
23,8		71	1,12	MR 31 81 - 24 x 200 90 LB 4	58,8	
24,1		70	1,9	MR 31 100 - 24 x 200 90 LB 4	58	

P_1 kW	n_2 min ⁻¹	M_2 daN m	f_s	Riduttore - Motore Gear reducer - Motor	i
1)				2)	
1,85	24,1	70	2,5	MR 31 101 - 24 x 200 90 LB 4	58
	26,4	64	2	MR 31 100 - 24 x 200 90 LB 4	53,1
	26,4	64	2,8	MR 31 101 - 24 x 200 90 LB 4	53,1
	26,5	64	1,06	MR 31 80 - 24 x 200 90 LB 4	52,9
	26,5	64	1,32	MR 31 81 - 24 x 200 90 LB 4	52,9
	28,9	59	2,24	MR 31 100 - 28 x 250 100 LB 6	31,2
	29,9	57	1,18	MR 31 80 - 24 x 200 90 LB 4	46,9
	29,9	57	1,6	MR 31 81 - 24 x 200 90 LB 4	46,9
	30,5	56	2,36	MR 31 100 - 24 x 200 90 LB 4	45,9
	32,9	52	1,25	MR 31 80 - 28 x 250 100 LB 6	27,4
	32,9	52	1,7	MR 31 81 - 28 x 250 100 LB 6	27,4
	35,2	48,2	1,4	MR 31 80 - 24 x 200 90 LB 4	39,8
	35,2	48,2	1,8	MR 31 81 - 24 x 200 90 LB 4	39,8
	36,3	46,7	0,9	MR 31 64 - 24 x 200 90 LB 4	38,5
	36,4	46,5	2,8	MR 31 100 - 24 x 200 90 LB 4	38,4
	40	42,4	3	MR 31 100 - 24 x 200 90 LB 4	35
	40,2	42,2	0,8	MR 31 63 - 24 x 200 90 LB 4	34,8
	40,2	42,2	1,06	MR 31 64 - 24 x 200 90 LB 4	34,8
	40,3	42,1	1,5	MR 31 80 - 24 x 200 90 LB 4	34,8
	40,3	42,1	2	MR 31 81 - 24 x 200 90 LB 4	34,8
	43,8	38,8	3,35	MR 31 100 - 24 x 200 90 LB 4	32
	44,2	38,4	0,85	MR 31 63 - 24 x 200 90 LB 4	31,7
	44,2	38,4	1,12	MR 31 64 - 24 x 200 90 LB 4	31,7
	45,5	37,3	1,7	MR 31 80 - 24 x 200 90 LB 4	30,8
	45,5	37,3	2,36	MR 31 81 - 24 x 200 90 LB 4	30,8
	48,1	35,3	0,85	MR 31 63 - 24 x 200 90 LB 4	29,1
	48,1	35,3	1,12	MR 31 64 - 24 x 200 90 LB 4	29,1
	48,7	34,8	1,9	MR 31 80 - 28 x 250 100 LB 6	18,5
	48,7	34,8	2,5	MR 31 81 - 28 x 250 100 LB 6	18,5
	53,6	31,7	1	MR 31 63 - 24 x 200 90 LB 4	26,1
	53,6	31,7	1,32	MR 31 64 - 24 x 200 90 LB 4	26,1
	53,6	31,7	2	MR 31 80 - 24 x 200 90 LB 4	26,1
	53,6	31,7	2,8	MR 31 81 - 24 x 200 90 LB 4	26,1
	55,4	31,3	1,9	MR 21 80 - 28 x 250 100 LB 6	16,3
	57,1	30,3	1,7	MR 21 80 - 24 x 200 90 LB 4	24,5
	57,7	30	0,85	MR 21 63 - 19 x 200 90 LB *	24,3
	59,3	28,6	1,12	MR 31 63 - 24 x 200 90 LB 4	23,6
	59,3	28,6	1,5	MR 31 64 - 24 x 200 90 LB 4	23,6
	59,7	28,4	2,24	MR 31 80 - 24 x 200 90 LB 4	23,5
	59,7	28,4	3	MR 31 81 - 24 x 200 90 LB 4	23,5
	62,1	27,9	2,12	MR 21 80 - 28 x 250 100 LB 6	14,5
	62,1	27,9	2,8	MR 21 81 - 28 x 250 100 LB 6	14,5
	65,2	26	1,25	MR 31 63 - 24 x 200 90 LB 4	21,5
	65,2	26	1,6	MR 31 64 - 24 x 200 90 LB 4	21,5
	68,7	24,7	2,65	MR 31 80 - 24 x 200 90 LB 4	20,4
	69,8	24,8	2,36	MR 21 80 - 24 x 200 90 LB 4	20,1
	69,8	24,8	2,8	MR 21 81 - 24 x 200 90 LB 4	20,1
	73,7	23,5	1,18	MR 21 63 - 19 x 200 90 LB *	19
	73,7	23,5	1,5	MR 21 64 - 19 x 200 90 LB *	19
	76,2	22,3	1,4	MR 31 63 - 24 x 200 90 LB 4	18,4
	76,2	22,3	1,9	MR 31 64 - 24 x 200 90 LB 4	18,4
	78,3	22,1	2,65	MR 21 80 - 24 x 200 90 LB 4	17,9
	82,7	20,9	1,4	MR 21 63 - 19 x 200 90 LB *	16,9
	82,7	20,9	1,8	MR 21 64 - 19 x 200 90 LB *	16,9
	84,7	20	1,6	MR 31 63 - 24 x 200 90 LB 4	16,5
	84,7	20	2,12	MR 31 64 - 24 x 200 90 LB 4	16,5
	86,4	20	1,25	MR 21 63 - 24 x 200 90 LB 4	16,2
	87,1	19,9	3,15	MR 21 80 - 24 x 200 90 LB 4	16,1
	92,1	18,8	1,6	MR 21 63 - 19 x 200 90 LB *	15,2
	92,1	18,8	2,12	MR 21 64 - 19 x 200 90 LB *	15,2
	93,4	18,5	0,95	MR 21 51 - 24 x 200 100 LB *	9,64
	96,6	17,9	3,35	MR 21 80 - 24 x 200 90 LB 4	14,5
	98,8	17,5	1,7	MR 21 63 - 19 x 200 90 LB *	14,2
	98,8	17,5	2,12	MR 21 64 - 19 x 200 90 LB *	14,2
	104	16,7	0,85	MR 21 50 - 24 x 200 100 LB *	8,67
	104	16,7	1,12	MR 21 51 - 24 x 200 100 LB *	8,67
	108	16,1	3,75	MR 21 80 - 24 x 200 90 LB 4	13
	110	15,7	1,9	MR 21 63 - 19 x 200 90 LB *	12,7
110	15,7	1,8	MR 21 63 - 24 x 200 90 LB 4	12,7	
110	15,7	2,5	MR 21 64 - 19 x 200 90 LB *	12,7	

Motor (cat. TX) with efficiency value not according to IE3 class (IEC 60034-30); the nominal power and nameplate data refer to intermittent duty S3 70%.

1) Powers valid for continuous duty S1; **increase** possible for S2 ... S10 (ch. 2b) in which case P_2 and M_2 increase and f_s decreases proportionately.

2) For complete designation when ordering, see ch. 3.

* Mounting position **B5R** (see table ch. 2b).

** Mounting position **B5A** (see table ch. 2b).

Gearmotors selection tables

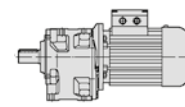

3.7

P_1 kW	n_2 min ⁻¹	M_2 daN m	f_s	Riduttore - Motore Gear reducer - Motor				i
1)				2)				
1.85	110	15,7	2,12	MR 2I 64 - 24 x 200	90 LB	4	12,7	
	114	15,1	0,85	MR 2I 50 - 19 x 200	90 LB *	4	12,2	
	114	15,1	1,12	MR 2I 51 - 19 x 200	90 LB *	4	12,2	
	115	15,1	0,95	MR 2I 50 - 24 x 200	100 LB *	6	7,85	
	115	15,1	1,32	MR 2I 51 - 24 x 200	100 LB *	6	7,85	
	120	14,5	0,85	MR 2I 50 - 24 x 200	90 LB	4	11,7	
	124	14	2,12	MR 2I 63 - 24 x 200	90 LB	4	11,3	
	124	14	2,65	MR 2I 64 - 24 x 200	90 LB	4	11,3	
	127	13,6	1	MR 2I 50 - 19 x 200	90 LB *	4	11	
	127	13,6	1,4	MR 2I 51 - 19 x 200	90 LB *	4	11	
	138	12,6	2,36	MR 2I 63 - 24 x 200	90 LB	4	10,2	
	138	12,6	3,15	MR 2I 64 - 24 x 200	90 LB	4	10,2	
	141	12,3	1,6	MR 2I 51 - 19 x 200	90 LB *	4	9,96	
	145	11,9	1,12	MR 2I 50 - 24 x 200	90 LB	4	9,64	
	145	11,9	1,4	MR 2I 51 - 24 x 200	90 LB	4	9,64	
	153	11,4	2,65	MR 2I 63 - 24 x 200	90 LB	4	9,18	
	162	10,7	1,25	MR 2I 50 - 24 x 200	90 LB	4	8,67	
	162	10,7	1,7	MR 2I 51 - 24 x 200	90 LB	4	8,67	
	168	10,3	2,8	MR 2I 63 - 24 x 200	90 LB	4	8,34	
	169	10,3	1,4	MR 2I 50 - 19 x 200	90 LB *	4	8,29	
	169	10,3	2	MR 2I 51 - 19 x 200	90 LB *	4	8,29	
	178	9,7	1,4	MR 2I 50 - 24 x 200	90 LB	4	7,85	
	178	9,7	2	MR 2I 51 - 24 x 200	90 LB	4	7,85	
	196	8,8	1,6	MR 2I 50 - 24 x 200	90 LB	4	7,14	
	196	8,8	2,24	MR 2I 51 - 24 x 200	90 LB	4	7,14	
	196	8,8	3,35	MR 2I 63 - 24 x 200	90 LB	4	7,14	
	214	8,1	1,7	MR 2I 50 - 24 x 200	90 LB	4	6,53	
	214	8,1	2,5	MR 2I 51 - 24 x 200	90 LB	4	6,53	
	218	7,9	3,75	MR 2I 63 - 24 x 200	90 LB	4	6,42	
	248	7	2	MR 2I 50 - 24 x 200	90 LB	4	5,65	
	248	7	2,65	MR 2I 51 - 24 x 200	90 LB	4	5,65	
	274	6,3	2,24	MR 2I 50 - 24 x 200	90 LB	4	5,11	
	274	6,3	2,65	MR 2I 51 - 24 x 200	90 LB	4	5,11	
	342	5,1	2,24	MR 2I 50 - 24 x 200	90 LB	4	4,1	
2.2	7.68	263	0,95	MR 3I 125 - 28 x 250	112 M	6	117	
	7.68	263	1,12	MR 3I 126 - 28 x 250	112 M	6	117	
	7.68	263	1,6	MR 3I 140 - 28 x 250	112 M	6	117	
	9.36	216	1	MR 3I 125 - 28 x 250	100 LA	4	150	
	9.42	214	2,24	MR 3I 140 - 28 x 250	112 M	6	95,5	
	9.6	210	1,25	MR 3I 125 - 28 x 250	112 M	6	93,7	
	9.6	210	1,6	MR 3I 126 - 28 x 250	112 M	6	93,7	
	11.5	175	1	MR 3I 101 - 28 x 250	112 M	6	77,9	
	11.8	170	0,9	MR 3I 101 - 24 x 200	90 LC	4	118	
	12	169	1,4	MR 3I 125 - 28 x 250	100 LA	4	117	
	12	169	1,8	MR 3I 126 - 28 x 250	100 LA	4	117	
	12	169	2,5	MR 3I 140 - 28 x 250	100 LA	4	117	
	12.1	167	1,6	MR 3I 125 - 28 x 250	112 M	6	74,4	
	12.1	167	2,12	MR 3I 126 - 28 x 250	112 M	6	74,4	
	14.2	142	0,95	MR 3I 100 - 28 x 250	112 M	6	63,2	
	14.2	142	1,25	MR 3I 101 - 28 x 250	112 M	6	63,2	
	14.6	138	0,9	MR 3I 100 - 28 x 250	100 LA	4	95,7	
	14.6	139	0,95	MR 3I 100 - 24 x 200	90 LC	4	96,2	
	14.6	138	1,06	MR 3I 101 - 28 x 250	100 LA	4	95,7	
	14.6	139	1,25	MR 3I 101 - 24 x 200	90 LC	4	96,2	
	14.9	135	2	MR 3I 125 - 28 x 250	100 LA	4	93,7	
	14.9	135	2,5	MR 3I 126 - 28 x 250	100 LA	4	93,7	
	15.8	128	1	MR 3I 100 - 28 x 250	112 M	6	57,1	
	15.8	128	1,32	MR 3I 101 - 28 x 250	112 M	6	57,1	
	16.3	124	2,12	MR 3I 125 - 28 x 250	112 M	6	55,3	
	16.3	124	2,8	MR 3I 126 - 28 x 250	112 M	6	55,3	
	18	112	1,18	MR 3I 100 - 28 x 250	100 LA	4	77,9	
	18	112	1,18	MR 3I 100 - 24 x 200	90 LC	4	77,9	
	18	112	1,6	MR 3I 101 - 28 x 250	100 LA	4	77,9	
	18	112	1,6	MR 3I 101 - 24 x 200	90 LC	4	77,9	
	18.8	107	2,5	MR 3I 125 - 28 x 250	100 LA	4	74,4	
	19.5	104	2,5	MR 3I 125 - 28 x 250	112 M	6	46,2	
	20.7	97	0,9	MR 3I 81 - 24 x 200	90 LC	4	67,5	
	20.9	97	1,4	MR 3I 100 - 28 x 250	112 M	6	43,1	

P_1 kW	n_2 min ⁻¹	M_2 daN m	f_s	Riduttore - Motore Gear reducer - Motor				i
1)				2)				
2.2	20,9	97	1,9	MR 3I 101 - 28 x 250	112 M	6	43,1	
	21,1	96	0,8	MR 3I 81 - 28 x 250	100 LA	4	66,4	
	21,6	93	0,95	MR 3I 81 - 28 x 250	112 M	6	41,7	
	22	92	1,4	MR 3I 100 - 24 x 200	90 LC	4	63,8	
	22	92	1,9	MR 3I 101 - 24 x 200	90 LC	4	63,8	
	22,1	91	1,4	MR 3I 100 - 28 x 250	100 LA	4	63,2	
	22,1	91	1,9	MR 3I 101 - 28 x 250	100 LA	4	63,2	
	22,9	88	3	MR 3I 125 - 28 x 250	100 LA	4	61,2	
	23,6	85	0,95	MR 3I 81 - 28 x 250	100 LA	4	59,2	
	23,8	85	0,95	MR 3I 81 - 24 x 200	90 LC	4	58,8	
	24,1	84	1,6	MR 3I 100 - 24 x 200	90 LC	4	58	
	24,1	84	2,12	MR 3I 101 - 24 x 200	90 LC	4	58	
	24,5	82	1,5	MR 3I 100 - 28 x 250	100 LA	4	57,1	
	24,5	82	2	MR 3I 101 - 28 x 250	100 LA	4	57,1	
	25,3	80	3,35	MR 3I 125 - 28 x 250	100 LA	4	55,3	
	26,3	77	0,85	MR 3I 80 - 28 x 250	100 LA	4	53,2	
	26,3	77	1,12	MR 3I 81 - 28 x 250	100 LA	4	53,2	
	26,4	76	1,7	MR 3I 100 - 24 x 200	90 LC	4	53,1	
	26,4	76	2,36	MR 3I 101 - 24 x 200	90 LC	4	53,1	
	26,5	76	0,85	MR 3I 80 - 24 x 200	90 LC	4	52,9	
	26,5	76	1,12	MR 3I 81 - 24 x 200	90 LC	4	52,9	
	27,1	75	1,8	MR 3I 100 - 28 x 250	100 LA	4	51,7	
	27,1	75	2,36	MR 3I 101 - 28 x 250	100 LA	4	51,7	
	28,7	70	0,95	MR 3I 80 - 28 x 250	112 M	6	31,3	
	28,7	70	1,32	MR 3I 81 - 28 x 250	112 M	6	31,3	
	29,7	68	1,9	MR 3I 100 - 28 x 250	100 LA	4	47,1	
	29,7	68	2,65	MR 3I 101 - 28 x 250	100 LA	4	47,1	
	29,9	68	1	MR 3I 80 - 24 x 200	90 LC	4	46,9	
	29,9	68	1,32	MR 3I 81 - 24 x 200	90 LC	4	46,9	
	30,2	67	0,95	MR 3I 80 - 28 x 250	100 LA	4	46,4	
	30,2	67	1,18	MR 3I 81 - 28 x 250	100 LA	4	46,4	
	30,5	66	2	MR 3I 100 - 24 x 200	90 LC	4	45,9	
	30,5	66	2,8	MR 3I 101 - 24 x 200	90 LC	4	45,9	
	32,5	62	2,12	MR 3I 100 - 28 x 250	100 LA	4	43,1	
	32,5	62	2,8	MR 3I 101 - 28 x 250	100 LA	4	43,1	
	32,9	61	1,06	MR 3I 80 - 28 x 250	112 M	6	27,4	
	32,9	61	1,4	MR 3I 81 - 28 x 250	112 M	6	27,4	
	33,6	60	1,06	MR 3I 80 - 28 x 250	100 LA	4	41,7	
	33,6	60	1,4	MR 3I 81 - 28 x 250	100 LA	4	41,7	
	35,2	57	1,18	MR 3I 80 - 24 x 200	90 LC	4	39,8	
	35,2	57	1,6	MR 3I 81 - 24 x 200	90 LC	4	39,8	
	36,4	55	2,36	MR 3I 100 - 24 x 200	90 LC	4	38,4	
	37,6	54	2,5	MR 3I 100 - 28 x 250	100 LA	4	37,2	
	37,9	53	1,25	MR 3I 80 - 28 x 250	100 LA	4	36,9	
	37,9	53	1,6	MR 3I 81 - 28 x 250	100 LA	4	36,9	
	38,4	54	2	MR 2I 100 - 28 x 250	112 M	6	23,4	
	40	50	2,5	MR 3I 100 - 24 x 200	90 LC	4	35	
	40,2	50	0,85	MR 3I 64 - 24 x 200	90 LC	4	34,8	
	40,3	50	1,32	MR 3I 80 - 24 x 200	90 LC	4	34,8	
	40,3	50	1,7	MR 3I 81 - 24 x 200	90 LC	4	34,8	
	43,8	46,1	2,8	MR 3I 100 - 24 x 200	90 LC	4	32	
	44,2	45,6	0,95	MR 3I 64 - 24 x 200	90 LC	4	31,7	
	44,7	45,1	1,4	MR 3I 80 - 28 x 250	100 LA	4	31,3	
	44,7	45,1	1,9	MR 3I 81 - 28 x 250	100 LA	4	31,3	
	44,9	44,9	2,8	MR 3I 100 - 28 x 250	100 LA	4	31,2	
	45,3	45,4	1,12	MR 2I 80 - 28 x 250	112 M	6	19,9	
	45,5	44,4	1,5	MR 3I 80 - 24 x 200	90 LC	4	30,8	
45,5	44,4	2	MR 3I 81 - 24 x 200	90 LC	4	30,8		
46,7	44,1	2,65	MR 2I 100 - 28 x 250	112 M	6	19,3		
48,1	41,9	0,95	MR 3I 64 - 24 x 200	90 LC	4	29,1		
49,3	40,9	3,15	MR 3I 100 - 28 x 250	100 LA	4	28,4		
51,1	39,4	1,6	MR 3I 80 - 28 x 250	100 LA	4	27,4		
51,1	39,4	2,12	MR 3I 81 - 28 x 250	100 LA	4	27,4		
53,6	37,6	0,85	MR 3I 63 - 24 x 200	90 LC	4	26,1		
53,6	37,6	1,12	MR 3I 64 - 24 x 200	90 LC	4	26,1		
53,6	37,7	1,7	MR 3I 80 - 24 x 200	90 LC	4	26,1		
53,6	37,7	2,24	MR 3I 81 - 24 x 200	90 LC	4	26,1		
55,4	37,2	1,6	MR 2I 80 - 28 x 250	112 M	6	16,3		
55,4	37,2	1,9	MR 2I 81 - 28 x 250	112 M	6	16,3		
57,1	36,1	1,4	MR 2I 80 - 24 x 200	90 LC	4	24,5		
57,7	35	1,8	MR 3I 80 - 28 x 250	100 LA	4	24,3		
57,7	35	2,5	MR 3I 81 - 28 x 250	100 LA	4	24,3		

Motor (cat. TX) with efficiency value not according to IE3 class (IEC 60034-30); the nominal power and nameplate data refer to intermittent duty S3 70%.

1) Powers valid for continuous duty S1; increase possible for S2 ... S10 (ch. 2b) in which case P_2 and M_2 increase and f_s decreases proportionately.

2) For complete designation when ordering, see ch. 3.

* Mounting position B5R (see table ch. 2b).

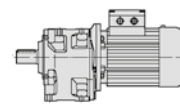

P_1 kW	n_2 min ⁻¹	M_2 daN m	f_s	Riduttore - Motore Gear reducer - Motor	i	
2,2	59,3	34	0,95	MR 3I 63 - 24 x 200 90 LC	4	23,6
	59,3	34	1,25	MR 3I 64 - 24 x 200 90 LC	4	23,6
	59,7	33,8	1,9	MR 3I 80 - 24 x 200 90 LC	4	23,5
	59,7	33,8	2,5	MR 3I 81 - 24 x 200 90 LC	4	23,5
	59,8	34,5	3,15	MR 2I 100 - 28 x 250 100 LA	4	23,4
	65,2	30,9	1	MR 3I 63 - 24 x 200 90 LC	4	21,5
	65,2	30,9	1,4	MR 3I 64 - 24 x 200 90 LC	4	21,5
	68	29,7	2,12	MR 3I 80 - 28 x 250 100 LA	4	20,6
	68	29,7	2,8	MR 3I 81 - 28 x 250 100 LA	4	20,6
	68,7	29,4	2,24	MR 3I 80 - 24 x 200 90 LC	4	20,4
	69,1	29,8	2,12	MR 2I 80 - 28 x 250 112 M	6	13
	69,1	29,8	2,8	MR 2I 81 - 28 x 250 112 M	6	13
	69,8	29,5	1,9	MR 2I 80 - 24 x 200 90 LC	4	20,1
	69,8	29,5	2,36	MR 2I 81 - 24 x 200 90 LC	4	20,1
	70,5	29,2	0,85	MR 2I 63 - 28 x 250 112 M	6	12,8
	70,5	29,2	1,7	MR 2I 80 - 28 x 250 100 LA	4	19,9
	75,7	26,6	2,36	MR 3I 80 - 28 x 250 100 LA	4	18,5
	76,2	26,5	1,18	MR 3I 63 - 24 x 200 90 LC	4	18,4
	76,2	26,5	1,6	MR 3I 64 - 24 x 200 90 LC	4	18,4
	78,3	26,3	2,24	MR 2I 80 - 24 x 200 90 LC	4	17,9
	84,7	23,8	1,32	MR 3I 63 - 24 x 200 90 LC	4	16,5
	84,7	23,8	1,8	MR 3I 64 - 24 x 200 90 LC	4	16,5
	86,2	23,9	2,36	MR 2I 80 - 28 x 250 100 LA	4	16,3
	86,2	23,9	2,8	MR 2I 81 - 28 x 250 100 LA	4	16,3
	86,4	23,8	1,06	MR 2I 63 - 24 x 200 90 LC	4	16,2
	87,1	23,6	2,65	MR 2I 80 - 24 x 200 90 LC	4	16,1
	87,2	23,1	2,8	MR 3I 80 - 28 x 250 100 LA	4	16,1
	90	22,9	1,25	MR 2I 63 - 28 x 250 112 M	6	10
	90	22,9	1,5	MR 2I 64 - 28 x 250 112 M	6	10
	96,6	21,3	2,8	MR 2I 80 - 28 x 250 100 LA	4	14,5
	96,6	21,3	2,8	MR 2I 80 - 24 x 200 90 LC	4	14,5
	101	20,4	1,4	MR 2I 63 - 28 x 250 112 M	6	8,91
	101	20,4	1,8	MR 2I 64 - 28 x 250 112 M	6	8,91
	108	19,1	3,15	MR 2I 80 - 28 x 250 100 LA	4	13
	110	18,8	1,32	MR 2I 63 - 28 x 250 100 LA	4	12,8
	110	18,7	1,5	MR 2I 63 - 24 x 200 90 LC	4	12,7
	110	18,7	1,8	MR 2I 64 - 24 x 200 90 LC	4	12,7
	113	18,3	1,7	MR 2I 63 - 28 x 250 112 M	6	8
	113	18,3	2,12	MR 2I 64 - 28 x 250 112 M	6	8
	114	18	0,95	MR 2I 51 - 19 x 200 90 LC *	4	12,2
	124	16,5	1,8	MR 2I 63 - 28 x 250 112 M	6	7,23
	124	16,6	1,7	MR 2I 63 - 24 x 200 90 LC	4	11,3
	124	16,5	2,5	MR 2I 64 - 28 x 250 112 M	6	7,23
	124	16,6	2,24	MR 2I 64 - 24 x 200 90 LC	4	11,3
	127	16,2	0,85	MR 2I 50 - 19 x 200 90 LC *	4	11
	127	16,2	1,12	MR 2I 51 - 19 x 200 90 LC *	4	11
	138	14,9	2	MR 2I 63 - 24 x 200 90 LC	4	10,2
	138	14,9	2,65	MR 2I 64 - 24 x 200 90 LC	4	10,2
	140	14,7	1,9	MR 2I 63 - 28 x 250 100 LA	4	10
	140	14,7	2,24	MR 2I 64 - 28 x 250 100 LA	4	10
	141	14,6	1,32	MR 2I 51 - 19 x 200 90 LC *	4	9,96
	145	14,2	0,9	MR 2I 50 - 24 x 200 90 LC	4	9,64
	145	14,2	1,18	MR 2I 51 - 24 x 200 90 LC	4	9,64
	153	13,5	2,24	MR 2I 63 - 24 x 200 90 LC	4	9,18
	153	13,5	3	MR 2I 64 - 24 x 200 90 LC	4	9,18
	157	13,1	2,12	MR 2I 63 - 28 x 250 100 LA	4	8,91
	157	13,1	2,8	MR 2I 64 - 28 x 250 100 LA	4	8,91
	162	12,7	1,06	MR 2I 50 - 24 x 200 90 LC	4	8,67
	162	12,7	1,4	MR 2I 51 - 24 x 200 90 LC	4	8,67
	168	12,3	2,5	MR 2I 63 - 24 x 200 90 LC	4	8,34
	169	12,2	1,18	MR 2I 50 - 19 x 200 90 LC *	4	8,29
	169	12,2	1,7	MR 2I 51 - 19 x 200 90 LC *	4	8,29
	175	11,8	2,5	MR 2I 63 - 28 x 250 100 LA	4	8
	175	11,8	3,35	MR 2I 64 - 28 x 250 100 LA	4	8
	178	11,5	1,18	MR 2I 50 - 24 x 200 90 LC	4	7,85
	178	11,5	1,7	MR 2I 51 - 24 x 200 90 LC	4	7,85
	194	10,6	2,8	MR 2I 63 - 28 x 250 100 LA	4	7,23
	196	10,5	1,32	MR 2I 50 - 24 x 200 90 LC	4	7,14
	196	10,5	1,9	MR 2I 51 - 24 x 200 90 LC	4	7,14
	196	10,5	2,8	MR 2I 63 - 24 x 200 90 LC	4	7,14
	213	9,7	3	MR 2I 63 - 28 x 250 100 LA	4	6,57

P_1 kW	n_2 min ⁻¹	M_2 daN m	f_s	Riduttore - Motore Gear reducer - Motor	i	
2,2	214	9,6	1,4	MR 2I 50 - 24 x 200 90 LC	4	6,53
	214	9,6	2,12	MR 2I 51 - 24 x 200 90 LC	4	6,53
	218	9,4	3,15	MR 2I 63 - 24 x 200 90 LC	4	6,42
	248	8,3	1,7	MR 2I 50 - 24 x 200 90 LC	4	5,65
	248	8,3	2,24	MR 2I 51 - 24 x 200 90 LC	4	5,65
	249	8,3	3,55	MR 2I 63 - 28 x 250 100 LA	4	5,63
	274	7,5	1,9	MR 2I 50 - 24 x 200 90 LC	4	5,11
	274	7,5	2,24	MR 2I 51 - 24 x 200 90 LC	4	5,11
	277	7,4	4	MR 2I 63 - 28 x 250 100 LA	4	5,06
	342	6	1,9	MR 2I 50 - 24 x 200 90 LC	4	4,1
	342	6	2,24	MR 2I 51 - 24 x 200 90 LC	4	4,1
	392	5,3	2,5	MR 2I 50 - 24 x 200 90 LA	2	7,14
	392	5,3	3,55	MR 2I 51 - 24 x 200 90 LA	2	7,14
	429	4,8	2,8	MR 2I 50 - 24 x 200 90 LA	2	6,53
	496	4,15	3,15	MR 2I 50 - 24 x 200 90 LA	2	5,65
	548	3,76	3,55	MR 2I 50 - 24 x 200 90 LA	2	5,11
	684	3,01	3,75	MR 2I 50 - 24 x 200 90 LA	2	4,1
3	7,31	376	2,24	MR 3I 180 - 38 x 300 132 S	6	123
	7,54	365	1,6	MR 3I 160 - 38 x 300 132 S	6	119
	7,68	358	0,85	MR 3I 126 - 28 x 250 112 MC	6	117
	7,68	358	1,18	MR 3I 140 - 28 x 250 112 MC	6	117
	8,97	306	2,24	MR 3I 160 - 38 x 300 132 S	6	100
	9,42	292	1,7	MR 3I 140 - 28 x 250 112 MC	6	95,5
	9,6	286	0,95	MR 3I 125 - 28 x 250 112 MC	6	93,7
	9,6	286	1,18	MR 3I 126 - 28 x 250 112 MC	6	93,7
	10,7	256	2,65	MR 3I 160 - 38 x 300 132 S	6	83,8
	11,9	232	2,12	MR 3I 140 - 28 x 250 112 MC	6	75,8
	12	230	1,06	MR 3I 125 - 28 x 250 112 MA	4	117
	12	230	1,32	MR 3I 126 - 28 x 250 112 MA	4	117
	12	230	1,8	MR 3I 140 - 28 x 250 112 MA	4	117
	12,1	227	1,18	MR 3I 125 - 28 x 250 112 MC	6	74,4
	12,1	227	1,5	MR 3I 126 - 28 x 250 112 MC	6	74,4
	14,2	193	0,9	MR 3I 101 - 28 x 250 112 MC	6	63,2
	14,6	188	0,8	MR 3I 101 - 28 x 250 112 MA	4	95,7
	14,7	188	2,65	MR 3I 140 - 28 x 250 112 MA	4	95,5
	14,9	184	1,4	MR 3I 125 - 28 x 250 112 MA	4	93,7
	14,9	184	1,9	MR 3I 126 - 28 x 250 112 MA	4	93,7
	15,8	175	0,95	MR 3I 101 - 28 x 250 112 MC	6	57,1
	16,2	170	3	MR 3I 140 - 28 x 250 112 MC	6	55,7
	16,3	169	1,6	MR 3I 125 - 28 x 250 112 MC	6	55,3
	16,3	169	2,12	MR 3I 126 - 28 x 250 112 MC	6	55,3
	17,7	155	3,15	MR 3I 140 - 28 x 250 112 MC	6	50,8
	18	153	0,85	MR 3I 100 - 28 x 250 112 MA	4	77,9
	18	153	1,12	MR 3I 101 - 28 x 250 112 MA	4	77,9
	18,8	146	1,8	MR 3I 125 - 28 x 250 112 MA	4	74,4
	18,8	146	2,36	MR 3I 126 - 28 x 250 112 MA	4	74,4
	19,1	144	0,9	MR 3I 100 - 28 x 250 112 MC	6	47,1
	19,1	144	1,25	MR 3I 101 - 28 x 250 112 MC	6	47,1
	19,3	143	3,15	MR 3I 140 - 28 x 250 112 MC	6	46,7
	19,5	141	1,8	MR 3I 125 - 28 x 250 112 MC	6	46,2
	19,5	141	2,36	MR 3I 126 - 28 x 250 112 MC	6	46,2
	19,7	140	0,9	MR 3I 100 - 38 x 300 132 S	6	45,7
	19,7	140	1,18	MR 3I 101 - 38 x 300 132 S	6	45,7
	20,2	136	1,9	MR 3I 125 - 38 x 300 132 S	6	44,5
	20,9	132	1	MR 3I 100 - 28 x 250 112 MC	6	43,1
	20,9	132	1,4	MR 3I 101 - 28 x 250 112 MC	6	43,1
	22,1	124	1,06	MR 3I 100 - 28 x 250 112 MA	4	63,2
	22,1	124	1,4	MR 3I 101 - 28 x 250 112 MA	4	63,2
	22,9	120	2,24	MR 3I 125 - 28 x 250 112 MA	4	61,2
	22,9	120	2,8	MR 3I 126 - 28 x 250 112 MA	4	61,2
	24,2	114	1,6	MR 3I 101 - 28 x 250 112 MC	6	37,2
	24,5	112	1,12	MR 3I 100 - 28 x 250 112 MA	4	57,1
	24,5	112	1,5	MR 3I 101 - 28 x 250 112 MA	4	57,1
	25,3	109	2,5	MR 3I 125 - 28 x 250 112 MA	4	55,3
	26,3	105	0,85	MR 3I 81 - 28 x 250 112 MA	4	53,2
	27,1	102	1,32	MR 3I 100 - 28 x 250 112 MA	4	51,7
	27,1	102	1,7	MR 3I 101 - 28 x 250 112 MA	4	51,7

Motor (cat. TX) with efficiency value not according to IE3 class (IEC 60034-30); the nominal power and nameplate data refer to intermittent duty S3 70%.

1) Powers valid for continuous duty S1; increase possible for S2 ... S10 (ch. 2b) in which case P_2 and M_2 increase and f_s decreases proportionately.
2) For complete designation when ordering, see ch. 3.

* Mounting position B5R (see table ch. 2b).

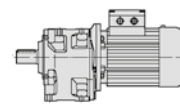

P_1 kW	n_2 min ⁻¹	M_2 daNm	f_s	Riduttore - Motore Gear reducer - Motor	i	P_1 kW	n_2 min ⁻¹	M_2 daNm	f_s	Riduttore - Motore Gear reducer - Motor	i
1)				2)		1)				2)	
4	14.9	245	1,4	MR 3I 126 - 28 x 250 112 M	4	72.6	52	2,65	MR 2I 101 - 28 x 250 112 M	4	19,3
	15,7	234	3	MR 3I 160 - 38 x 300 132 M	6	75,7	48,4	1,32	MR 3I 80 - 28 x 250 112 M	4	18,5
	16,2	226	2	MR 3I 140 - 38 x 300 132 M	6	75,7	48,4	1,8	MR 3I 81 - 28 x 250 112 M	4	18,5
	16,4	223	1,12	MR 3I 125 - 38 x 300 132 M	6	78,3	47,8	1,25	MR 2I 80 - 24 x 200 112 M	*	4 17,9
	16,4	223	1,5	MR 3I 126 - 38 x 300 132 M	6	78,3	47,8	1,6	MR 2I 81 - 24 x 200 112 M	*	4 17,9
	18	204	0,85	MR 3I 101 - 28 x 250 112 M	4	80,8	46,3	2,5	MR 2I 100 - 28 x 250 112 M	4	17,3
	18,5	199	2,36	MR 3I 140 - 28 x 250 112 M	4	86,2	43,5	1,32	MR 2I 80 - 28 x 250 112 M	4	16,3
	18,8	195	1,4	MR 3I 125 - 28 x 250 112 M	4	86,2	43,5	1,6	MR 2I 81 - 28 x 250 112 M	4	16,3
	18,8	195	1,8	MR 3I 126 - 28 x 250 112 M	4	87,1	43	1,4	MR 2I 80 - 24 x 200 112 M	*	4 16,1
	19,7	186	0,9	MR 3I 101 - 38 x 300 132 M	6	87,1	43	1,9	MR 2I 81 - 24 x 200 112 M	*	4 16,1
	20,1	183	2,65	MR 3I 140 - 38 x 300 132 M	6	87,2	42,1	1,5	MR 3I 80 - 28 x 250 112 M	4	16,1
	20,2	181	1,5	MR 3I 125 - 38 x 300 132 M	6	87,2	42,1	2	MR 3I 81 - 28 x 250 112 M	4	16,1
	20,2	181	2	MR 3I 126 - 38 x 300 132 M	6	89,2	42	3	MR 2I 100 - 28 x 250 112 M	4	15,7
	22,1	166	0,8	MR 3I 100 - 28 x 250 112 M	4	96,6	38,7	1,5	MR 2I 80 - 28 x 250 112 M	4	14,5
	22,1	166	1,06	MR 3I 101 - 28 x 250 112 M	4	96,6	38,7	1,9	MR 2I 81 - 28 x 250 112 M	4	14,5
	22,5	163	3	MR 3I 140 - 28 x 250 112 M	4	102	36,8	3,15	MR 2I 100 - 28 x 250 112 M	4	13,8
	22,9	160	1,7	MR 3I 125 - 28 x 250 112 M	4	108	34,8	1,7	MR 2I 80 - 28 x 250 112 M	4	13
	22,9	160	2,12	MR 3I 126 - 28 x 250 112 M	4	108	34,8	2,24	MR 2I 81 - 28 x 250 112 M	4	13
	24,5	150	0,85	MR 3I 100 - 28 x 250 112 M	4	110	33,9	1	MR 2I 64 - 24 x 200 112 M	*	4 12,7
	24,5	150	1,12	MR 3I 101 - 28 x 250 112 M	4	112	33,3	3,55	MR 2I 100 - 28 x 250 112 M	4	12,5
	25,3	145	1,8	MR 3I 125 - 28 x 250 112 M	4	119	31,4	1,8	MR 2I 80 - 28 x 250 112 M	4	11,8
	25,3	145	2,5	MR 3I 126 - 28 x 250 112 M	4	119	31,4	2,36	MR 2I 81 - 28 x 250 112 M	4	11,8
	26,1	141	0,95	MR 3I 100 - 38 x 300 132 M	6	121	30,9	2	MR 2I 80 - 24 x 200 112 M	*	4 11,5
	26,1	141	1,32	MR 3I 101 - 38 x 300 132 M	6	121	30,9	2,65	MR 2I 81 - 24 x 200 112 M	*	4 11,5
	27,1	135	0,95	MR 3I 100 - 28 x 250 112 M	4	124	30,2	0,95	MR 2I 63 - 24 x 200 112 M	*	4 11,3
	27,1	135	1,25	MR 3I 101 - 28 x 250 112 M	4	124	30,2	1,18	MR 2I 64 - 24 x 200 112 M	*	4 11,3
	27,9	132	2	MR 3I 125 - 28 x 250 112 M	4	124	30,3	4	MR 2I 100 - 28 x 250 112 M	4	11,3
	27,9	132	2,65	MR 3I 126 - 28 x 250 112 M	4	133	28,3	2,12	MR 2I 80 - 28 x 250 112 M	4	10,6
	29,7	123	1,06	MR 3I 100 - 28 x 250 112 M	4	133	28,3	2,8	MR 2I 81 - 28 x 250 112 M	4	10,6
	29,7	123	1,4	MR 3I 101 - 28 x 250 112 M	4	138	27,2	1,12	MR 2I 63 - 24 x 200 112 M	*	4 10,2
	30,3	121	2,12	MR 3I 125 - 28 x 250 112 M	4	138	27,2	1,4	MR 2I 64 - 24 x 200 112 M	*	4 10,2
	30,3	121	2,65	MR 3I 126 - 28 x 250 112 M	4	140	26,7	1,06	MR 2I 63 - 28 x 250 112 M	4	10
	32,5	113	1,18	MR 3I 100 - 28 x 250 112 M	4	140	26,7	1,25	MR 2I 64 - 28 x 250 112 M	4	10
	32,5	113	1,6	MR 3I 101 - 28 x 250 112 M	4	150	25	2,36	MR 2I 80 - 28 x 250 112 M	4	9,36
	33,6	109	0,8	MR 3I 81 - 28 x 250 112 M	4	150	25	3,15	MR 2I 81 - 28 x 250 112 M	4	9,36
	33,8	109	2,36	MR 3I 125 - 28 x 250 112 M	4	157	23,8	1,18	MR 2I 63 - 28 x 250 112 M	4	8,91
	36,1	102	1,25	MR 3I 100 - 38 x 300 132 M	6	157	23,8	1,5	MR 2I 64 - 28 x 250 112 M	4	8,91
	36,1	102	1,7	MR 3I 101 - 38 x 300 132 M	6	158	23,8	2,5	MR 2I 80 - 38 x 300 132 M	6	5,71
	37,1	101	2,12	MR 2I 125 - 38 x 300 132 M	6	168	22,3	1,32	MR 2I 63 - 24 x 200 112 M	*	4 8,34
	37,3	98	2,65	MR 3I 125 - 28 x 250 112 M	4	168	22,3	1,8	MR 2I 64 - 24 x 200 112 M	*	4 8,34
	37,6	98	1,32	MR 3I 100 - 28 x 250 112 M	4	175	21,4	1,4	MR 2I 63 - 28 x 250 112 M	4	8
	37,6	98	1,8	MR 3I 101 - 28 x 250 112 M	4	175	21,4	1,8	MR 2I 64 - 28 x 250 112 M	4	8
	37,9	97	0,9	MR 3I 81 - 28 x 250 112 M	4	176	21,2	2,8	MR 2I 80 - 28 x 250 112 M	4	7,95
	41,1	89	3	MR 3I 125 - 28 x 250 112 M	4	178	21	0,9	MR 2I 51 - 24 x 200 112 M	*	4 7,85
	44,7	82	0,8	MR 3I 80 - 28 x 250 112 M	4	194	19,3	1,5	MR 2I 63 - 28 x 250 112 M	4	7,23
	44,7	82	1,06	MR 3I 81 - 28 x 250 112 M	4	194	19,3	2	MR 2I 64 - 28 x 250 112 M	4	7,23
	44,9	82	1,6	MR 3I 100 - 28 x 250 112 M	4	196	19,1	1,06	MR 2I 51 - 24 x 200 112 M	*	4 7,14
	44,9	82	2	MR 3I 101 - 28 x 250 112 M	4	196	19,1	3,15	MR 2I 80 - 28 x 250 112 M	4	7,13
	47,4	79	3	MR 2I 125 - 38 x 300 132 M	6	213	17,6	1,7	MR 2I 63 - 28 x 250 112 M	4	6,57
	49,3	74	1,7	MR 3I 100 - 28 x 250 112 M	4	213	17,6	2,24	MR 2I 64 - 28 x 250 112 M	4	6,57
	49,3	74	2,36	MR 3I 101 - 28 x 250 112 M	4	214	17,5	1,12	MR 2I 51 - 24 x 200 112 M	*	4 6,53
	51,1	72	0,9	MR 3I 80 - 28 x 250 112 M	4	226	16,6	3,55	MR 2I 80 - 28 x 250 112 M	4	6,2
	51,1	72	1,18	MR 3I 81 - 28 x 250 112 M	4	248	15,1	1,25	MR 2I 51 - 24 x 200 112 M	*	4 5,65
	53,9	68	1,9	MR 3I 100 - 28 x 250 112 M	4	249	15	2	MR 2I 63 - 28 x 250 112 M	4	5,63
	53,9	68	2,5	MR 3I 101 - 28 x 250 112 M	4	249	15	2,36	MR 2I 64 - 28 x 250 112 M	4	5,63
	57,7	66	0,8	MR 2I 80 - 24 x 200 112 M	*	274	13,7	1,25	MR 2I 51 - 24 x 200 112 M	*	4 5,11
	57,7	64	1	MR 3I 80 - 28 x 250 112 M	4	277	13,5	2,12	MR 2I 63 - 28 x 250 112 M	4	5,06
	57,7	64	1,32	MR 3I 81 - 28 x 250 112 M	4	277	13,5	2,36	MR 2I 64 - 28 x 250 112 M	4	5,06
	59,8	63	1,7	MR 2I 100 - 28 x 250 112 M	4	342	11	1,25	MR 2I 51 - 24 x 200 112 M	*	4 4,1
	60,1	62	1,7	MR 2I 100 - 38 x 300 132 M	6	350	10,7	2,24	MR 2I 63 - 28 x 250 112 M	4	4
	62,4	59	2,12	MR 3I 100 - 28 x 250 112 M	4	350	10,7	2,36	MR 2I 64 - 28 x 250 112 M	4	4
	62,4	59	3	MR 3I 101 - 28 x 250 112 M	4						
	68	54	1,18	MR 3I 80 - 28 x 250 112 M	4	5,5	7,31	689	1,25	MR 3I 180 - 38 x 300 132 MB	6 123
	68	54	1,6	MR 3I 81 - 28 x 250 112 M	4	7,54	669	0,9	MR 3I 160 - 38 x 300 132 MB	6 119	
	69	53	2,36	MR 3I 100 - 28 x 250 112 M	4	8,93	565	1,7	MR 3I 180 - 38 x 300 132 MB	6 101	
	69,8	54	1,06	MR 2I 80 - 24 x 200 112 M	*	8,97	562	1,25	MR 3I 160 - 38 x 300 132 MB	6 100	
	69,8	54	1,32	MR 2I 81 - 24 x 200 112 M	*	10,7	469	1,5	MR 3I 160 - 38 x 300 132 MB	6 83,8	
	70,5	53	0,95	MR 2I 80 - 28 x 250 112 M	4	10,7	472	2	MR 3I 180 - 38 x 300 132 MB	6 84,2	
	72,6	52	2,24	MR 2I 100 - 28 x 250 112 M	4	11,4	443	1,9	MR 3I 180 - 38 x 300 132 S	4 123	

1) Powers valid for continuous duty S1; **increase** possible for S2 ... S10 (ch. 2b) in which case P_2 and M_2 increase and f_s decreases proportionately.
2) For complete designation when ordering, see ch. 3.

* Mounting position **B5R** (see table ch. 2b).

Gearmotors selection tables

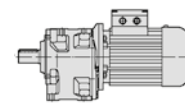

3.7

P_1 kW	n_2 min ⁻¹	M_2 daN m	f_s	Riduttore - Motore Gear reducer - Motor	i
1)				2)	
5,5	11,7	430	1,4	MR 3I 160 - 38 x 300 132 S	4 119
	12	419	1	MR 3I 140 - 38 x 300 132 MB	6 74,8
	12	422	1	MR 3I 140 - 28 x 250 112 MC	4 117
	13,9	363	2,65	MR 3I 180 - 38 x 300 132 S	4 101
	14	361	1,9	MR 3I 160 - 38 x 300 132 S	4 100
	14,7	344	1,4	MR 3I 140 - 28 x 250 112 MC	4 95,5
	14,9	338	0,8	MR 3I 125 - 28 x 250 112 MC	4 93,7
	14,9	338	1	MR 3I 126 - 28 x 250 112 MC	4 93,7
	16,2	310	1,5	MR 3I 140 - 38 x 300 132 MB	6 55,4
	16,4	307	0,85	MR 3I 125 - 38 x 300 132 MB	6 54,8
	16,4	307	1,06	MR 3I 126 - 38 x 300 132 MB	6 54,8
	16,6	303	3	MR 3I 180 - 38 x 300 132 S	4 84,2
	16,7	302	2,24	MR 3I 160 - 38 x 300 132 S	4 83,8
	17,9	281	1,7	MR 3I 140 - 38 x 300 132 MB	6 50,2
	18,1	279	2,5	MR 3I 160 - 38 x 300 132 MB	6 49,7
	18,3	276	0,95	MR 3I 125 - 38 x 300 132 MB	6 49,3
	18,3	276	1,25	MR 3I 126 - 38 x 300 132 MB	6 49,3
	18,5	273	1,8	MR 3I 140 - 28 x 250 112 MC	4 75,8
	18,7	270	0,9	MR 3I 125 - 38 x 300 132 S	4 74,8
	18,7	270	1,12	MR 3I 126 - 38 x 300 132 S	4 74,8
	18,7	270	1,6	MR 3I 140 - 38 x 300 132 S	4 74,8
	18,8	268	1	MR 3I 125 - 28 x 250 112 MC	4 74,4
	18,8	268	1,32	MR 3I 126 - 28 x 250 112 MC	4 74,4
	20,1	251	2	MR 3I 140 - 38 x 300 132 MB	6 44,9
	20,2	249	1,06	MR 3I 125 - 38 x 300 132 MB	6 44,5
	20,2	249	1,4	MR 3I 126 - 38 x 300 132 MB	6 44,5
	20,9	242	2,8	MR 3I 160 - 38 x 300 132 MB	6 43,1
	21,3	236	3	MR 3I 160 - 38 x 300 132 S	4 65,6
	22,5	225	2,12	MR 3I 140 - 28 x 250 112 MC	4 62,3
	22,9	220	1,18	MR 3I 125 - 28 x 250 112 MC	4 61,2
	22,9	220	1,6	MR 3I 126 - 28 x 250 112 MC	4 61,2
	22,9	220	2,12	MR 3I 140 - 38 x 300 132 S	4 61
	23,4	216	1,25	MR 3I 125 - 38 x 300 132 S	4 59,9
	23,4	216	1,6	MR 3I 126 - 38 x 300 132 S	4 59,9
	23,9	211	0,85	MR 3I 101 - 38 x 300 132 MB	6 37,7
	24,4	207	3,35	MR 3I 160 - 38 x 300 132 S	4 57,4
	24,5	206	0,8	MR 3I 101 - 28 x 250 112 MC	4 57,1
	25,1	201	2,5	MR 3I 140 - 28 x 250 112 MC	4 55,7
	25,3	199	1,32	MR 3I 125 - 28 x 250 112 MC	4 55,3
	25,3	199	1,8	MR 3I 126 - 28 x 250 112 MC	4 55,3
	25,3	200	2,24	MR 3I 140 - 38 x 300 132 S	4 55,4
	25,5	198	1,32	MR 3I 125 - 38 x 300 132 S	4 54,8
	25,5	198	1,6	MR 3I 126 - 38 x 300 132 S	4 54,8
	26,1	193	0,95	MR 3I 101 - 38 x 300 132 MB	6 34,5
	27,1	186	0,95	MR 3I 101 - 28 x 250 112 MC	4 51,7
	27,6	182	0,95	MR 3I 101 - 38 x 300 132 S	4 50,6
	27,6	183	2,65	MR 3I 140 - 28 x 250 112 MC	4 50,8
	27,9	181	1,5	MR 3I 125 - 28 x 250 112 MC	4 50,2
	27,9	181	2	MR 3I 126 - 28 x 250 112 MC	4 50,2
	27,9	181	2,65	MR 3I 140 - 38 x 300 132 S	4 50,2
	28,4	177	1,5	MR 3I 125 - 38 x 300 132 S	4 49,3
	28,4	177	1,9	MR 3I 126 - 38 x 300 132 S	4 49,3
	29,7	170	0,8	MR 3I 100 - 28 x 250 112 MC	4 47,1
	29,7	170	1,06	MR 3I 101 - 28 x 250 112 MC	4 47,1
	30	168	2,65	MR 3I 140 - 28 x 250 112 MC	4 46,7
	30,3	166	1,5	MR 3I 125 - 28 x 250 112 MC	4 46,2
	30,3	166	1,9	MR 3I 126 - 28 x 250 112 MC	4 46,2
	30,6	165	1	MR 3I 101 - 38 x 300 132 S	4 45,7
	31,2	162	3	MR 3I 140 - 38 x 300 132 S	4 44,9
	31,4	160	1,6	MR 3I 125 - 38 x 300 132 S	4 44,5
	31,4	160	2,24	MR 3I 126 - 38 x 300 132 S	4 44,5
	32,5	155	0,85	MR 3I 100 - 28 x 250 112 MC	4 43,1
	32,5	155	1,12	MR 3I 101 - 28 x 250 112 MC	4 43,1
	33,8	149	0,85	MR 3I 100 - 38 x 300 132 S	4 41,4
	33,8	149	1,12	MR 3I 101 - 38 x 300 132 S	4 41,4
	33,8	149	1,7	MR 3I 125 - 28 x 250 112 MC	4 41,5
	33,8	149	2,24	MR 3I 126 - 28 x 250 112 MC	4 41,5
	34,6	146	1,8	MR 3I 125 - 38 x 300 132 S	4 40,5
	34,6	146	2,36	MR 3I 126 - 38 x 300 132 S	4 40,5
	37,1	136	0,95	MR 3I 100 - 38 x 300 132 S	4 37,7
	37,1	136	1,32	MR 3I 101 - 38 x 300 132 S	4 37,7

P_1 kW	n_2 min ⁻¹	M_2 daN m	f_s	Riduttore - Motore Gear reducer - Motor	i
1)				2)	
5,5	37,1	139	1,5	MR 2I 125 - 38 x 300 132 MB	6 24,3
	37,3	135	1,9	MR 3I 125 - 28 x 250 112 MC	4 37,5
	37,3	135	2,5	MR 3I 126 - 28 x 250 112 MC	4 37,5
	37,3	135	3,35	MR 3I 140 - 38 x 300 132 S	4 37,6
	37,6	134	1	MR 3I 100 - 28 x 250 112 MC	4 37,2
	37,6	134	1,32	MR 3I 101 - 28 x 250 112 MC	4 37,2
	37,6	134	1,9	MR 3I 125 - 38 x 300 132 S	4 37,2
	37,6	134	2,36	MR 3I 126 - 38 x 300 132 S	4 37,2
	40,6	124	1,06	MR 3I 100 - 38 x 300 132 S	4 34,5
	40,6	124	1,4	MR 3I 101 - 38 x 300 132 S	4 34,5
	41,1	123	2,12	MR 3I 125 - 28 x 250 112 MC	4 34,1
	41,9	120	2,12	MR 3I 125 - 38 x 300 132 S	4 33,4
	41,9	120	2,8	MR 3I 126 - 38 x 300 132 S	4 33,4
	44,7	113	0,8	MR 3I 81 - 28 x 250 112 MC	4 31,3
	44,9	112	1,12	MR 3I 100 - 28 x 250 112 MC	4 31,2
	44,9	112	1,5	MR 3I 101 - 28 x 250 112 MC	4 31,2
	46,4	109	2,36	MR 3I 125 - 38 x 300 132 S	4 30,2
	47	107	1,18	MR 3I 100 - 38 x 300 132 S	4 29,8
	47	107	1,6	MR 3I 101 - 38 x 300 132 S	4 29,8
	47,4	109	2,12	MR 2I 125 - 38 x 300 132 MB	6 19
	49,3	102	1,25	MR 3I 100 - 28 x 250 112 MC	4 28,4
	49,3	102	1,7	MR 3I 101 - 28 x 250 112 MC	4 28,4
	51	99	2,65	MR 3I 125 - 38 x 300 132 S	4 27,4
	51,1	99	0,85	MR 3I 81 - 28 x 250 112 MC	4 27,4
	53,9	93	1,32	MR 3I 100 - 28 x 250 112 MC	4 26
	53,9	93	1,8	MR 3I 101 - 28 x 250 112 MC	4 26
	56,1	90	1,4	MR 3I 100 - 38 x 300 132 S	4 25
	56,1	90	1,8	MR 3I 101 - 38 x 300 132 S	4 25
	57,7	87	1	MR 3I 81 - 28 x 250 112 MC	4 24,3
	57,7	89	2,36	MR 2I 125 - 38 x 300 132 S	4 24,3
	59,6	85	3	MR 3I 125 - 38 x 300 132 S	4 23,5
	59,8	86	1,25	MR 2I 100 - 28 x 250 112 MC	4 23,4
	60,1	86	1,25	MR 2I 100 - 38 x 300 132 MB	6 15
	61,6	82	1,5	MR 3I 100 - 38 x 300 132 S	4 22,7
	61,6	82	2,12	MR 3I 101 - 38 x 300 132 S	4 22,7
	62,4	81	1,6	MR 3I 100 - 28 x 250 112 MC	4 22,4
	62,4	81	2,12	MR 3I 101 - 28 x 250 112 MC	4 22,4
	66,3	76	3,35	MR 3I 125 - 38 x 300 132 S	4 21,1
	67,4	75	1,7	MR 3I 100 - 38 x 300 132 S	4 20,8
	67,4	75	2,24	MR 3I 101 - 38 x 300 132 S	4 20,8
	68	74	0,85	MR 3I 80 - 28 x 250 112 MC	4 20,6
	68	74	1,18	MR 3I 81 - 28 x 250 112 MC	4 20,6
	69	73	1,7	MR 3I 100 - 28 x 250 112 MC	4 20,3
	69	73	2,36	MR 3I 101 - 28 x 250 112 MC	4 20,3
	72,6	71	1,6	MR 2I 100 - 28 x 250 112 MC	4 19,3
	72,6	71	2	MR 2I 101 - 28 x 250 112 MC	4 19,3
	73,1	70	1,6	MR 2I 100 - 38 x 300 132 MB	6 12,3
	73,1	70	2	MR 2I 101 - 38 x 300 132 MB	6 12,3
	73,7	70	3,35	MR 2I 125 - 38 x 300 132 S	4 19
	75,7	67	0,95	MR 3I 80 - 28 x 250 112 MC	4 18,5
	75,7	67	1,32	MR 3I 81 - 28 x 250 112 MC	4 18,5
	77,9	65	1,9	MR 3I 100 - 38 x 300 132 S	4 18
	77,9	65	2,65	MR 3I 101 - 38 x 300 132 S	4 18
	80,8	64	1,9	MR 2I 100 - 28 x 250 112 MC	4 17,3
	80,8	64	2,36	MR 2I 101 - 28 x 250 112 MC	4 17,3
	85,2	60	1,12	MR 2I 81 - 38 x 300 132 MB	6 10,6
	86,1	59	2,12	MR 3I 100 - 38 x 300 132 S	4 16,3
	86,1	59	3	MR 3I 101 - 38 x 300 132 S	4 16,3
	86,2	60	0,95	MR 2I 80 - 28 x 250 112 MC	4 16,3
	86,2	60	1,18	MR 2I 81 - 28 x 250 112 MC	4 16,3
	87,2	58	1,12	MR 3I 80 - 28 x 250 112 MC	4 16,1
	87,2	58	1,5	MR 3I 81 - 28 x 250 112 MC	4 16,1
	89,2	58	2,12	MR 3I 100 - 28 x 250 112 MC	4 15,7
	89,2	58	2,8	MR 3I 101 - 28 x 250 112 MC	4 15,7
	93,5	55	1,9	MR 2I 100 - 38 x 300 132 S	4 15
	96,6	53	1,12	MR 2I 80 - 28 x 250 112 MC	4 14,5
	96,6	53	1,4	MR 2I 81 - 28 x 250 112 MC	4 14,5
	102	51	2,36	MR 2I 100 - 28 x 250 112 MC	4 13,8
	106	48,4	1,25	MR 2I 80 - 38 x 300 132 MB	6 8,46
	106	48,4	1,6	MR 2I 81 - 38 x 300 132 MB	6 8,46
	108	47,9	1,25	MR 2I 80 - 28 x 250 112 MC	4 13
	108	47,5	1,06	MR 2I 80 - 38 x 300 132 S	4 12,9

Motor (cat. TX) with efficiency value not according to IE3 class (IEC 60034-30); the nominal power and nameplate data refer to intermittent duty S3 70%.

1) Powers valid for continuous duty S1; increase possible for S2 ... S10 (ch. 2b) in which case P_2 and M_2 increase and f_s decreases proportionately.
2) For complete designation when ordering, see ch. 3.

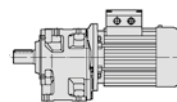

P_1 kW	n_2 min ⁻¹	M_2 daNm	f_s	Riduttore - Motore Gear reducer - Motor	i	
1)	2)					
5,5	108	47,9	1,7	MR 2I 81 - 28 x 250 112 MC	4	13
	112	45,8	2,65	MR 2I 100 - 28 x 250 112 MC	4	12,5
	114	45,3	2,5	MR 2I 100 - 38 x 300 132 S	4	12,3
	114	45,3	3	MR 2I 101 - 38 x 300 132 S	4	12,3
	119	43,2	1,32	MR 2I 80 - 28 x 250 112 MC	4	11,8
	119	43,2	1,7	MR 2I 81 - 28 x 250 112 MC	4	11,8
	120	42,9	1,4	MR 2I 80 - 38 x 300 132 MB	6	7,5
	120	42,9	1,9	MR 2I 81 - 38 x 300 132 MB	6	7,5
	124	41,7	2,8	MR 2I 100 - 28 x 250 112 MC	4	11,3
	126	40,7	2,8	MR 2I 100 - 38 x 300 132 S	4	11,1
	133	38,8	1,5	MR 2I 80 - 28 x 250 112 MC	4	10,6
	133	38,8	1,4	MR 2I 80 - 38 x 300 132 S	4	10,6
	133	38,8	2	MR 2I 81 - 28 x 250 112 MC	4	10,6
	133	38,8	1,7	MR 2I 81 - 38 x 300 132 S	4	10,6
	135	38,1	3,15	MR 2I 100 - 28 x 250 112 MC	4	10,4
	140	36,8	0,9	MR 2I 64 - 28 x 250 112 MC	4	10
	140	36,9	3,15	MR 2I 100 - 38 x 300 132 S	4	10
	141	36,4	2,24	MR 2I 81 - 38 x 300 132 MB	6	6,36
	149	34,6	1,7	MR 2I 80 - 38 x 300 132 S	4	9,41
	149	34,6	2,12	MR 2I 81 - 38 x 300 132 S	4	9,41
	150	34,4	1,7	MR 2I 80 - 28 x 250 112 MC	4	9,36
	150	34,4	2,36	MR 2I 81 - 28 x 250 112 MC	4	9,36
	153	33,6	3,55	MR 2I 100 - 38 x 300 132 S	4	9,13
	157	32,8	0,85	MR 2I 63 - 28 x 250 112 MC	4	8,91
	157	32,8	1,12	MR 2I 64 - 28 x 250 112 MC	4	8,91
	165	31,1	1,9	MR 2I 80 - 38 x 300 132 S	4	8,46
	165	31,1	2,5	MR 2I 81 - 38 x 300 132 S	4	8,46
	175	29,4	1	MR 2I 63 - 28 x 250 112 MC	4	8
	175	29,4	1,32	MR 2I 64 - 28 x 250 112 MC	4	8
	176	29,2	2	MR 2I 80 - 28 x 250 112 MC	4	7,95
	176	29,2	2,8	MR 2I 81 - 28 x 250 112 MC	4	7,95
	187	27,6	2,12	MR 2I 80 - 38 x 300 132 S	4	7,5
	187	27,6	2,8	MR 2I 81 - 38 x 300 132 S	4	7,5
	194	26,6	1,12	MR 2I 63 - 28 x 250 112 MC	4	7,23
	194	26,6	1,5	MR 2I 64 - 28 x 250 112 MC	4	7,23
	196	26,2	2,24	MR 2I 80 - 28 x 250 112 MC	4	7,13
	196	26,2	3	MR 2I 81 - 28 x 250 112 MC	4	7,13
	213	24,2	1,18	MR 2I 63 - 28 x 250 112 MC	4	6,57
	213	24,2	1,6	MR 2I 64 - 28 x 250 112 MC	4	6,57
	220	23,4	2,5	MR 2I 80 - 38 x 300 132 S	4	6,36
	226	22,8	2,65	MR 2I 80 - 28 x 250 112 MC	4	6,2
	245	21	2,8	MR 2I 80 - 38 x 300 132 S	4	5,71
	249	20,7	1,4	MR 2I 63 - 28 x 250 112 MC	4	5,63
	249	20,7	1,8	MR 2I 64 - 28 x 250 112 MC	4	5,63
	277	18,6	1,6	MR 2I 63 - 28 x 250 112 MC	4	5,06
	277	18,6	1,8	MR 2I 64 - 28 x 250 112 MC	4	5,06
	282	18,2	3,15	MR 2I 80 - 38 x 300 132 S	4	4,96
	350	14,7	1,7	MR 2I 63 - 28 x 250 112 MC	4	4
	350	14,7	1,8	MR 2I 64 - 28 x 250 112 MC	4	4
	353	14,6	3,35	MR 2I 80 - 38 x 300 132 S	4	3,96

P_1 kW	n_2 min ⁻¹	M_2 daNm	f_s	Riduttore - Motore Gear reducer - Motor	i		
1)	2)						
7,5	18,1	380	1,9	MR 3I 160 - 38 x 300 132 MC	6	49,7	
	18,3	376	0,9	MR 3I 126 - 38 x 300 132 MC	6	49,3	
	18,3	376	0,9	MR 3I 126 - 42 x 350 160 M	6	49,3	
	18,5	372	2,5	MR 3I 180 - 38 x 300 132 MC	6	48,7	
	18,7	368	0,8	MR 3I 126 - 38 x 300 132 M	4	74,8	
	18,7	368	1,18	MR 3I 140 - 38 x 300 132 M	4	74,8	
	20,1	343	1,4	MR 3I 140 - 38 x 300 132 MC	6	44,9	
	20,2	340	0,8	MR 3I 125 - 38 x 300 132 MC	6	44,5	
	20,2	340	1,06	MR 3I 126 - 38 x 300 132 MC	6	44,5	
	20,8	331	1,4	MR 3I 140 - 42 x 350 160 M	6	43,4	
	20,9	329	2,12	MR 3I 160 - 38 x 300 132 MC	6	43,1	
	21,2	324	3	MR 3I 180 - 42 x 350 160 M	6	42,5	
	21,2	324	3	MR 3I 180 - 38 x 300 132 M	4	65,9	
	21,3	322	2,12	MR 3I 160 - 38 x 300 132 M	4	65,6	
	22,9	300	1,6	MR 3I 140 - 38 x 300 132 M	4	61	
	23,4	294	0,9	MR 3I 125 - 38 x 300 132 M	4	59,9	
	23,4	294	1,18	MR 3I 126 - 38 x 300 132 M	4	59,9	
	24,4	282	2,5	MR 3I 160 - 38 x 300 132 M	4	57,4	
	25,3	272	1,7	MR 3I 140 - 38 x 300 132 M	4	55,4	
	25,5	269	0,95	MR 3I 125 - 38 x 300 132 M	4	54,8	
	25,5	269	1,18	MR 3I 126 - 38 x 300 132 M	4	54,8	
	25,8	266	1,32	MR 3I 126 - 42 x 350 160 M	6	34,8	
	26,4	260	1,9	MR 3I 140 - 38 x 300 132 MC	6	34	
	27,9	247	1,9	MR 3I 140 - 38 x 300 132 M	4	50,2	
	28,2	244	3	MR 3I 160 - 38 x 300 132 M	4	49,7	
	28,4	242	1,06	MR 3I 125 - 38 x 300 132 M	4	49,3	
	28,4	242	1,4	MR 3I 126 - 38 x 300 132 M	4	49,3	
	29,6	232	2,12	MR 3I 140 - 38 x 300 132 MC	6	30,4	
	30,2	228	0,8	MR 3I 101 - 38 x 300 132 MC	6	29,8	
	31,2	220	2,24	MR 3I 140 - 38 x 300 132 M	4	44,9	
	31,4	219	1,18	MR 3I 125 - 38 x 300 132 M	4	44,5	
	31,4	219	1,6	MR 3I 126 - 38 x 300 132 M	4	44,5	
	32,5	212	3,15	MR 3I 160 - 38 x 300 132 M	4	43,1	
	33,8	203	0,85	MR 3I 101 - 38 x 300 132 M	4	41,4	
	34,3	201	2,36	MR 3I 140 - 38 x 300 132 M	4	40,9	
	34,6	199	1,32	MR 3I 125 - 38 x 300 132 M	4	40,5	
	34,6	199	1,8	MR 3I 126 - 38 x 300 132 M	4	40,5	
	37,1	185	0,95	MR 3I 101 - 38 x 300 132 M	4	37,7	
	37,3	185	2,36	MR 3I 140 - 38 x 300 132 M	4	37,6	
	37,6	183	1,32	MR 3I 125 - 38 x 300 132 M	4	37,2	
	37,6	183	1,7	MR 3I 126 - 38 x 300 132 M	4	37,2	
	40,6	169	1,06	MR 3I 101 - 38 x 300 132 M	4	34,5	
	41,1	167	2,8	MR 3I 140 - 38 x 300 132 M	4	34	
	41,9	164	1,6	MR 3I 125 - 38 x 300 132 M	4	33,4	
	41,9	164	2	MR 3I 126 - 38 x 300 132 M	4	33,4	
	44,4	158	1,32	MR 2I 125 - 42 x 350 160 M	6	20,3	
	46	149	3,15	MR 3I 140 - 38 x 300 132 M	4	30,4	
	46,4	148	1,7	MR 3I 125 - 38 x 300 132 M	4	30,2	
	46,4	148	2,36	MR 3I 126 - 38 x 300 132 M	4	30,2	
	47	146	0,9	MR 3I 100 - 38 x 300 132 M	4	29,8	
	47	146	1,18	MR 3I 101 - 38 x 300 132 M	4	29,8	
	47,4	148	1,6	MR 2I 125 - 38 x 300 132 MC	6	19	
	50,1	137	0,95	MR 3I 100 - 38 x 300 132 MC	6	18	
	50,1	137	1,25	MR 3I 101 - 38 x 300 132 MC	6	18	
	51	135	1,9	MR 3I 125 - 38 x 300 132 M	4	27,4	
	51	135	2,5	MR 3I 126 - 38 x 300 132 M	4	27,4	
	56,1	123	1	MR 3I 100 - 38 x 300 132 M	4	25	
	56,1	123	1,32	MR 3I 101 - 38 x 300 132 M	4	25	
	56,7	124	1,9	MR 2I 125 - 42 x 350 160 M	6	15,9	
	57,7	122	1,7	MR 2I 125 - 38 x 300 132 M	4	24,3	
	59,2	119	2,12	MR 2I 125 - 38 x 300 132 MC	6	15,2	
	59,6	115	2,24	MR 3I 125 - 38 x 300 132 M	4	23,5	
	59,6	115	3	MR 3I 126 - 38 x 300 132 M	4	23,5	
	59,8	117	0,9	MR 2I 100 - 28 x 250 132 M	*	4	23,4
	60,1	117	0,9	MR 2I 100 - 38 x 300 132 MC	6	15	
	60,1	117	0,9	MR 2I 100 - 42 x 350 160 M	6	15	
	61,6	112	1,12	MR 3I 100 - 38 x 300 132 M	4	22,7	
	61,6	112	1,5	MR 3I 101 - 38 x 300 132 M	4	22,7	
	63,7	110	2,24	MR 2I 125 - 38 x 300 132 MC	6	14,1	
	66,3	104	2,5	MR 3I 125 - 38 x 300 132 M	4	21,1	
	67,4	102	1,25	MR 3I 100 - 38 x 300 132 M	4	20,8	

Motor (cat. TX) with efficiency value not according to IE3 class (IEC 60034-30); the nominal power and nameplate data refer to intermittent duty S3 70%.

1) Powers valid for continuous duty S1; **increase** possible for S2 ... S10 (ch. 2b) in which case P_2 and M_2 increase and f_s decreases proportionately.
2) For complete designation when ordering, see ch. 3.

* Mounting position **B5R** (see table ch. 2b).

Gearmotors selection tables

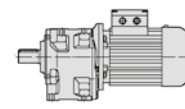

3.7

P_1 kW	n_2 min ⁻¹	M_2 daN m	f_s	Riduttore - Motore Gear reducer - Motor	i	
7,5	67,4	102	1,7	MR 3I 101 - 38 × 300 132 M	4	20,8
	72,6	97	1,18	MR 2I 100 - 28 × 250 132 M *	4	19,3
	72,6	97	1,4	MR 2I 101 - 28 × 250 132 M *	4	19,3
	73,1	96	1,18	MR 2I 100 - 38 × 300 132 MC	6	12,3
	73,1	96	1,18	MR 2I 100 - 42 × 350 160 M	6	12,3
	73,1	96	1,4	MR 2I 101 - 38 × 300 132 MC	6	12,3
	73,1	96	1,4	MR 2I 101 - 42 × 350 160 M	6	12,3
	73,7	95	2,36	MR 2I 125 - 38 × 300 132 M	4	19
	73,7	95	3	MR 2I 126 - 38 × 300 132 M	4	19
	77,9	88	1,4	MR 3I 100 - 38 × 300 132 M	4	18
	77,9	88	1,9	MR 3I 101 - 38 × 300 132 M	4	18
	80,8	87	1,4	MR 2I 100 - 28 × 250 132 M *	4	17,3
	80,8	87	1,7	MR 2I 101 - 28 × 250 132 M *	4	17,3
	81,3	86	1,4	MR 2I 100 - 38 × 300 132 MC	6	11,1
	81,3	86	1,4	MR 2I 100 - 42 × 350 160 M	6	11,1
	81,3	86	1,7	MR 2I 101 - 38 × 300 132 MC	6	11,1
	81,3	86	1,7	MR 2I 101 - 42 × 350 160 M	6	11,1
	82,7	85	2,8	MR 2I 125 - 38 × 300 132 M	4	16,9
	86,1	80	1,6	MR 3I 100 - 38 × 300 132 M	4	16,3
	86,1	80	2,12	MR 3I 101 - 38 × 300 132 M	4	16,3
	86,2	81	0,85	MR 2I 81 - 28 × 250 132 M *	4	16,3
	89,2	79	1,6	MR 2I 100 - 28 × 250 132 M *	4	15,7
	89,2	79	2	MR 2I 101 - 28 × 250 132 M *	4	15,7
	89,8	78	1,6	MR 2I 100 - 38 × 300 132 MC	6	10
	89,8	78	2	MR 2I 101 - 38 × 300 132 MC	6	10
	89,8	78	2	MR 2I 101 - 42 × 350 160 M	6	10
	92,1	76	3,15	MR 2I 125 - 38 × 300 132 M	4	15,2
	93,5	75	1,4	MR 2I 100 - 38 × 300 132 M	4	15
	96,6	73	0,8	MR 2I 80 - 28 × 250 132 M *	4	14,5
	96,6	73	1	MR 2I 81 - 28 × 250 132 M *	4	14,5
	98,6	71	1,7	MR 2I 100 - 38 × 300 132 MC	6	9,13
	98,6	71	2,36	MR 2I 101 - 38 × 300 132 MC	6	9,13
	99	71	3,35	MR 2I 125 - 38 × 300 132 M	4	14,1
	102	69	1,7	MR 2I 100 - 28 × 250 132 M *	4	13,8
	102	69	2,12	MR 2I 101 - 28 × 250 132 M *	4	13,8
	104	68	1,7	MR 2I 100 - 42 × 350 160 M	6	8,67
	104	68	2,24	MR 2I 101 - 42 × 350 160 M	6	8,67
	108	65	0,95	MR 2I 80 - 28 × 250 132 M *	4	13
	108	65	0,8	MR 2I 80 - 38 × 300 132 M	4	12,9
	108	65	1,18	MR 2I 81 - 28 × 250 132 M *	4	13
	110	64	3,75	MR 2I 125 - 38 × 300 132 M	4	12,7
	112	62	1,9	MR 2I 100 - 28 × 250 132 M *	4	12,5
	112	62	2,5	MR 2I 101 - 28 × 250 132 M *	4	12,5
	114	62	1,8	MR 2I 100 - 38 × 300 132 M	4	12,3
	114	62	2,24	MR 2I 101 - 38 × 300 132 M	4	12,3
	119	59	1	MR 2I 80 - 28 × 250 132 M *	4	11,8
	119	59	1,25	MR 2I 81 - 28 × 250 132 M *	4	11,8
	120	58	1,4	MR 2I 81 - 38 × 300 132 MC	6	7,5
	126	56	2,12	MR 2I 100 - 38 × 300 132 M	4	11,1
	126	56	2,65	MR 2I 101 - 38 × 300 132 M	4	11,1
	133	53	1,12	MR 2I 80 - 28 × 250 132 M *	4	10,6
	133	53	1,06	MR 2I 80 - 38 × 300 132 M	4	10,6
	133	53	1,5	MR 2I 81 - 28 × 250 132 M *	4	10,6
	133	53	1,25	MR 2I 81 - 38 × 300 132 M	4	10,6
	140	50	2,36	MR 2I 100 - 38 × 300 132 M	4	10
	140	50	3,15	MR 2I 101 - 38 × 300 132 M	4	10
	149	47,2	1,18	MR 2I 80 - 38 × 300 132 M	4	9,41
	149	47,2	1,5	MR 2I 81 - 38 × 300 132 M	4	9,41
	150	46,9	1,25	MR 2I 80 - 28 × 250 132 M *	4	9,36
	150	46,9	1,7	MR 2I 81 - 28 × 250 132 M *	4	9,36
	153	45,8	2,65	MR 2I 100 - 38 × 300 132 M	4	9,13
	165	42,4	1,4	MR 2I 80 - 38 × 300 132 M	4	8,46
	165	42,4	1,8	MR 2I 81 - 38 × 300 132 M	4	8,46
	168	41,9	2,8	MR 2I 100 - 38 × 300 132 M	4	8,35
	175	40,1	0,95	MR 2I 64 - 28 × 250 132 M *	4	8
	187	37,6	1,6	MR 2I 80 - 38 × 300 132 M	4	7,5
	187	37,6	2,12	MR 2I 81 - 38 × 300 132 M	4	7,5
	194	36,3	1,06	MR 2I 64 - 28 × 250 132 M *	4	7,23
	194	36,2	3,35	MR 2I 100 - 38 × 300 132 M	4	7,22
	196	35,8	1,7	MR 2I 80 - 28 × 250 132 M *	4	7,13
	196	35,8	2,24	MR 2I 81 - 28 × 250 132 M *	4	7,13

P_1 kW	n_2 min ⁻¹	M_2 daN m	f_s	Riduttore - Motore Gear reducer - Motor	i	
7,5	213	32,9	1,18	MR 2I 64 - 28 × 250 132 M *	4	6,57
	220	31,9	1,8	MR 2I 80 - 38 × 300 132 M	4	6,36
	220	31,9	2,5	MR 2I 81 - 38 × 300 132 M	4	6,36
	245	28,6	2	MR 2I 80 - 38 × 300 132 M	4	5,71
	245	28,6	2,5	MR 2I 81 - 38 × 300 132 M	4	5,71
	249	28,2	1,32	MR 2I 64 - 28 × 250 132 M *	4	5,63
	277	25,4	1,32	MR 2I 64 - 28 × 250 132 M *	4	5,06
	282	24,9	2,36	MR 2I 80 - 38 × 300 132 M	4	4,96
	282	24,9	2,5	MR 2I 81 - 38 × 300 132 M	4	4,96
	350	20,1	1,32	MR 2I 64 - 28 × 250 132 M *	4	4
	353	19,9	2,5	MR 2I 80 - 38 × 300 132 M	4	3,96
9,2	11,4	741	1,12	MR 3I 180 - 38 × 300 132 MB	4	123
	11,7	720	0,85	MR 3I 160 - 38 × 300 132 MB	4	119
	13,9	607	1,5	MR 3I 180 - 38 × 300 132 MB	4	101
	14	604	1,12	MR 3I 160 - 38 × 300 132 MB	4	100
	16,6	507	1,8	MR 3I 180 - 38 × 300 132 MB	4	84,2
	16,7	505	1,4	MR 3I 160 - 38 × 300 132 MB	4	83,8
	18,7	451	0,95	MR 3I 140 - 38 × 300 132 MB	4	74,8
	21,2	397	2,5	MR 3I 180 - 38 × 300 132 MB	4	65,9
	21,3	395	1,7	MR 3I 160 - 38 × 300 132 MB	4	65,6
	22,9	368	1,32	MR 3I 140 - 38 × 300 132 MB	4	61
	23,4	361	0,95	MR 3I 126 - 38 × 300 132 MB	4	59,9
	24,4	346	2	MR 3I 160 - 38 × 300 132 MB	4	57,4
	24,5	344	2,8	MR 3I 180 - 38 × 300 132 MB	4	57,1
	25,3	334	1,4	MR 3I 140 - 38 × 300 132 MB	4	55,4
	25,5	330	0,95	MR 3I 126 - 38 × 300 132 MB	4	54,8
	27,9	302	1,6	MR 3I 140 - 38 × 300 132 MB	4	50,2
	28,2	300	2,36	MR 3I 160 - 38 × 300 132 MB	4	49,7
	28,4	297	0,9	MR 3I 125 - 38 × 300 132 MB	4	49,3
	28,4	297	1,12	MR 3I 126 - 38 × 300 132 MB	4	49,3
	28,8	293	3,15	MR 3I 180 - 38 × 300 132 MB	4	48,7
	31,2	270	1,8	MR 3I 140 - 38 × 300 132 MB	4	44,9
	31,4	268	1	MR 3I 125 - 38 × 300 132 MB	4	44,5
	31,4	268	1,32	MR 3I 126 - 38 × 300 132 MB	4	44,5
	32,5	260	2,65	MR 3I 160 - 38 × 300 132 MB	4	43,1
	34,3	246	1,9	MR 3I 140 - 38 × 300 132 MB	4	40,9
	34,6	244	1,06	MR 3I 125 - 38 × 300 132 MB	4	40,5
	34,6	244	1,4	MR 3I 126 - 38 × 300 132 MB	4	40,5
	37,1	227	0,8	MR 3I 101 - 38 × 300 132 MB	4	37,7
	37,1	227	3	MR 3I 160 - 38 × 300 132 MB	4	37,7
	37,3	226	2	MR 3I 140 - 38 × 300 132 MB	4	37,6
	37,6	224	1,12	MR 3I 125 - 38 × 300 132 MB	4	37,2
	37,6	224	1,4	MR 3I 126 - 38 × 300 132 MB	4	37,2
	40,6	208	0,85	MR 3I 101 - 38 × 300 132 MB	4	34,5
	41,1	205	2,24	MR 3I 140 - 38 × 300 132 MB	4	34
	41,9	201	1,25	MR 3I 125 - 38 × 300 132 MB	4	33,4
	41,9	201	1,7	MR 3I 126 - 38 × 300 132 MB	4	33,4
	46	183	2,65	MR 3I 140 - 38 × 300 132 MB	4	30,4
	46,4	182	1,4	MR 3I 125 - 38 × 300 132 MB	4	30,2
	46,4	182	1,9	MR 3I 126 - 38 × 300 132 MB	4	30,2
	47	180	1	MR 3I 101 - 38 × 300 132 MB	4	29,8
	51	165	1,5	MR 3I 125 - 38 × 300 132 MB	4	27,4
	51	165	2,12	MR 3I 126 - 38 × 300 132 MB	4	27,4
	53,7	157	3,15	MR 3I 140 - 38 × 300 132 MB	4	26,1
	56,1	150	0,85	MR 3I 100 - 38 × 300 132 MB	4	25
	56,1	150	1,12	MR 3I 101 - 38 × 300 132 MB	4	25
	57,7	149	1,4	MR 2I 125 - 38 × 300 132 MB	4	24,3
	59,6	141	1,8	MR 3I 125 - 38 × 300 132 MB	4	23,5
	59,6	141	2,36	MR 3I 126 - 38 × 300 132 MB	4	23,5
	61,6	137	0,9	MR 3I 100 - 38 × 300 132 MB	4	22,7
	61,6	137	1,25	MR 3I 101 - 38 × 300 132 MB	4	22,7
	66,3	127	2	MR 3I 125 - 38 × 300 132 MB	4	21,1
	66,3	127	2,65	MR 3I 126 - 38 × 300 132 MB	4	21,1
	67,4	125	1	MR 3I 100 - 38 × 300 132 MB	4	20,8
	67,4	125	1,32	MR 3I 101 - 38 × 300 132 MB	4	20,8
	73,7	117	1,9	MR 2I 125 - 38 × 300 132 MB	4	19
	73,7	117	2,36	MR 2I 126 - 38 × 300 132 MB	4	19
	77,9	108	1,18	MR 3I 100 - 38 × 300 132 MB	4	18

Motor (cat. TX) with efficiency value not according to IE3 class (IEC 60034-30); the nominal power and nameplate data refer to intermittent duty S3 70%.

1) Powers valid for continuous duty S1; increase possible for S2... S10 (ch. 2b) in which case P_2 and M_2 increase and f_s decreases proportionately.

2) For complete designation when ordering, see ch. 3.

* Mounting position B5R (see table ch. 2b).

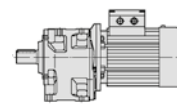

P_1 kW	n_2 min ⁻¹	M_2 daN m	f_s	Riduttore - Motore Gear reducer - Motor	i	P_1 kW	n_2 min ⁻¹	M_2 daN m	f_s	Riduttore - Motore Gear reducer - Motor	i			
1)				2)		1)				2)				
9,2	77,9	108	1,6	MR 3I 101 - 38 x 300	132 MB 4	18	11	382	2,5	MR 3I 180 - 42 x 350	160 M 4	53,1		
	82,7	104	2,24	MR 2I 125 - 38 x 300	132 MB 4	16,9		26,4	380	1,8	MR 3I 160 - 42 x 350	160 M 4	52,8	
	82,7	104	2,8	MR 2I 126 - 38 x 300	132 MB 4	16,9		26,5	380	2,5	MR 3I 180 - 38 x 300	132 MC 4	52,7	
	86,1	98	1,32	MR 3I 100 - 38 x 300	132 MB 4	16,3		27,9	362	1,32	MR 3I 140 - 38 x 300	132 MC 4	50,2	
	86,1	98	1,7	MR 3I 101 - 38 x 300	132 MB 4	16,3		27,9	362	1,32	MR 3I 140 - 42 x 350	160 M 4	50,2	
	92,1	93	2,65	MR 2I 125 - 38 x 300	132 MB 4	15,2		28,2	358	2	MR 3I 160 - 38 x 300	132 MC 4	49,7	
	93,5	92	1,12	MR 2I 100 - 38 x 300	132 MB 4	15		28,4	355	0,95	MR 3I 126 - 38 x 300	132 MC 4	49,3	
	99	87	2,65	MR 2I 125 - 38 x 300	132 MB 4	14,1		28,4	355	0,95	MR 3I 126 - 42 x 350	160 M 4	49,3	
	110	78	3,15	MR 2I 125 - 38 x 300	132 MB 4	12,7		28,8	351	2,65	MR 3I 180 - 38 x 300	132 MC 4	48,7	
	114	76	1,5	MR 2I 100 - 38 x 300	132 MB 4	12,3		30,3	333	2,12	MR 3I 160 - 42 x 350	160 M 4	46,2	
	114	76	1,8	MR 2I 101 - 38 x 300	132 MB 4	12,3		30,4	331	2,8	MR 3I 180 - 42 x 350	160 M 4	46	
	122	71	3,35	MR 2I 125 - 38 x 300	132 MB 4	11,5		31,2	323	1,5	MR 3I 140 - 38 x 300	132 MC 4	44,9	
	126	68	1,7	MR 2I 100 - 38 x 300	132 MB 4	11,1		31,4	321	0,8	MR 3I 125 - 38 x 300	132 MC 4	44,5	
	126	68	2,12	MR 2I 101 - 38 x 300	132 MB 4	11,1		31,4	321	1,12	MR 3I 126 - 38 x 300	132 MC 4	44,5	
	133	65	0,85	MR 2I 80 - 38 x 300	132 MB 4	10,6		32,3	312	1,4	MR 3I 140 - 42 x 350	160 M 4	43,4	
	133	65	1,06	MR 2I 81 - 38 x 300	132 MB 4	10,6		32,5	311	2,12	MR 3I 160 - 38 x 300	132 MC 4	43,1	
	140	62	1,9	MR 2I 100 - 38 x 300	132 MB 4	10		32,6	309	0,8	MR 3I 125 - 42 x 350	160 M 4	42,9	
	140	62	2,5	MR 2I 101 - 38 x 300	132 MB 4	10		32,6	309	1	MR 3I 126 - 42 x 350	160 M 4	42,9	
	149	58	1	MR 2I 80 - 38 x 300	132 MB 4	9,41		34,3	294	1,6	MR 3I 140 - 38 x 300	132 MC 4	40,9	
	149	58	1,25	MR 2I 81 - 38 x 300	132 MB 4	9,41		34,6	291	0,9	MR 3I 125 - 38 x 300	132 MC 4	40,5	
	153	56	2,12	MR 2I 100 - 38 x 300	132 MB 4	9,13		34,6	291	1,18	MR 3I 126 - 38 x 300	132 MC 4	40,5	
	153	56	2,8	MR 2I 101 - 38 x 300	132 MB 4	9,13		35	288	2,5	MR 3I 160 - 42 x 350	160 M 4	40	
	165	52	1,12	MR 2I 80 - 38 x 300	132 MB 4	8,46		35,6	283	1,7	MR 3I 140 - 42 x 350	160 M 4	39,3	
	165	52	1,5	MR 2I 81 - 38 x 300	132 MB 4	8,46		36,3	278	0,95	MR 3I 125 - 42 x 350	160 M 4	38,5	
	168	51	2,36	MR 2I 100 - 38 x 300	132 MB 4	8,35		36,3	278	1,18	MR 3I 126 - 42 x 350	160 M 4	38,5	
	168	51	3,15	MR 2I 101 - 38 x 300	132 MB 4	8,35		37,1	272	2,5	MR 3I 160 - 38 x 300	132 MC 4	37,7	
	187	46,1	1,25	MR 2I 80 - 38 x 300	132 MB 4	7,5		37,3	271	1,6	MR 3I 140 - 38 x 300	132 MC 4	37,6	
	187	46,1	1,7	MR 2I 81 - 38 x 300	132 MB 4	7,5		37,6	268	0,95	MR 3I 125 - 38 x 300	132 MC 4	37,2	
	194	44,4	2,65	MR 2I 100 - 38 x 300	132 MB 4	7,22		37,6	268	1,18	MR 3I 126 - 38 x 300	132 MC 4	37,2	
	214	40,2	3	MR 2I 100 - 38 x 300	132 MB 4	6,53		39,9	253	1,9	MR 3I 140 - 42 x 350	160 M 4	35,1	
	220	39,1	1,5	MR 2I 80 - 38 x 300	132 MB 4	6,36		40,2	251	1	MR 3I 125 - 42 x 350	160 M 4	34,8	
	220	39,1	2	MR 2I 81 - 38 x 300	132 MB 4	6,36		40,2	251	1,4	MR 3I 126 - 42 x 350	160 M 4	34,8	
	245	35,1	1,7	MR 2I 80 - 38 x 300	132 MB 4	5,71		40,3	250	2,65	MR 3I 160 - 42 x 350	160 M 4	34,7	
	245	35,1	2,12	MR 2I 81 - 38 x 300	132 MB 4	5,71		41,1	245	1,9	MR 3I 140 - 38 x 300	132 MC 4	34	
	282	30,5	1,9	MR 2I 80 - 38 x 300	132 MB 4	4,96		41,9	241	1,06	MR 3I 125 - 38 x 300	132 MC 4	33,4	
	282	30,5	2,12	MR 2I 81 - 38 x 300	132 MB 4	4,96		41,9	241	1,4	MR 3I 126 - 38 x 300	132 MC 4	33,4	
	353	24,4	2	MR 2I 80 - 38 x 300	132 MB 4	3,96		42,8	235	3	MR 3I 160 - 38 x 300	132 MC 4	32,7	
	353	24,4	2,12	MR 2I 81 - 38 x 300	132 MB 4	3,96		43,8	230	2	MR 3I 140 - 42 x 350	160 M 4	32	
	11	10,7	943	1	MR 3I 180 - 42 x 350	160 L 6		84,2	44,2	228	1,5	MR 3I 126 - 42 x 350	160 M 4	31,7
		11,4	886	0,95	MR 3I 180 - 38 x 300	132 MC 4		123	46	219	2,24	MR 3I 140 - 38 x 300	132 MC 4	30,4
		13,3	756	0,9	MR 3I 160 - 42 x 350	160 L 6		67,4	46,1	219	3,15	MR 3I 160 - 42 x 350	160 M 4	30,4
		13,6	740	1,12	MR 3I 180 - 42 x 350	160 M 4		103	46,4	217	1,18	MR 3I 125 - 38 x 300	132 MC 4	30,2
		13,9	726	1,32	MR 3I 180 - 38 x 300	132 MC 4		101	46,4	217	1,6	MR 3I 126 - 38 x 300	132 MC 4	30,2
		14	722	0,95	MR 3I 160 - 38 x 300	132 MC 4		100	47	215	0,8	MR 3I 101 - 38 x 300	132 MC 4	29,8
		16,6	606	1,5	MR 3I 180 - 38 x 300	132 MC 4		84,2	47,6	212	2,12	MR 3I 140 - 42 x 350	160 M 4	29,4
		16,6	606	1,5	MR 3I 180 - 42 x 350	160 M 4		84,2	48,1	210	1,18	MR 3I 125 - 42 x 350	160 M 4	29,1
		16,7	603	1,12	MR 3I 160 - 38 x 300	132 MC 4		83,8	48,1	210	1,5	MR 3I 126 - 42 x 350	160 M 4	29,1
16,7		603	1,12	MR 3I 160 - 42 x 350	160 M 4	83,8	51	198	1,32	MR 3I 125 - 38 x 300	132 MC 4	27,4		
17,9		563	0,85	MR 3I 140 - 42 x 350	160 L 6	50,2	51	198	1,7	MR 3I 126 - 38 x 300	132 MC 4	27,4		
20,7		488	1,9	MR 3I 180 - 42 x 350	160 M 4	67,8	51,9	198	3,15	MR 2I 160 - 42 x 350	160 L 6	17,3		
20,8		486	0,95	MR 3I 140 - 42 x 350	160 L 6	43,4	52,6	192	2,36	MR 3I 140 - 42 x 350	160 M 4	26,6		
20,8		486	1,4	MR 3I 160 - 42 x 350	160 M 4	67,4	53,6	188	1,32	MR 3I 125 - 42 x 350	160 M 4	26,1		
21,2		475	2	MR 3I 180 - 38 x 300	132 MC 4	65,9	53,6	188	1,7	MR 3I 126 - 42 x 350	160 M 4	26,1		
21,3		473	1,5	MR 3I 160 - 38 x 300	132 MC 4	65,6	53,6	188	2,65	MR 3I 140 - 38 x 300	132 MC 4	26,1		
22,5		449	1,6	MR 3I 160 - 42 x 350	160 L 6	40	56,1	180	0,9	MR 3I 101 - 38 x 300	132 MC 4	25		
22,9		440	1,06	MR 3I 140 - 38 x 300	132 MC 4	61	57,7	178	1,18	MR 2I 125 - 38 x 300	132 MC 4	24,3		
22,9		440	1,06	MR 3I 140 - 42 x 350	160 M 4	61	58,8	171	2,8	MR 3I 140 - 42 x 350	160 M 4	23,8		
23,3		432	0,8	MR 3I 126 - 42 x 350	160 L 6	38,5	59,3	170	1,5	MR 3I 125 - 42 x 350	160 M 4	23,6		
23,4		431	0,8	MR 3I 126 - 38 x 300	132 MC 4	59,9	59,3	170	2	MR 3I 126 - 42 x 350	160 M 4	23,6		
23,5		430	2,12	MR 3I 180 - 42 x 350	160 M 4	59,6	59,4	170	2,65	MR 3I 140 - 38 x 300	132 MC 4	23,6		
24,3		414	1,6	MR 3I 160 - 42 x 350	160 M 4	57,5	59,6	169	1,5	MR 3I 125 - 38 x 300	132 MC 4	23,5		
24,4		413	1,7	MR 3I 160 - 38 x 300	132 MC 4	57,4	59,6	169	2	MR 3I 126 - 38 x 300	132 MC 4	23,5		
24,5		412	2,36	MR 3I 180 - 38 x 300	132 MC 4	57,1	61,6	164	1,06	MR 3I 101 - 38 x 300	132 MC 4	22,7		
25,3		399	1,12	MR 3I 140 - 38 x 300	132 MC 4	55,4	65,2	155	1,6	MR 3I 125 - 42 x 350	160 M 4	21,5		
25,3		399	1,12	MR 3I 140 - 42 x 350	160 M 4	55,4	65,2	155	2,24	MR 3I 126 - 42 x 350	160 M 4	21,5		
25,5		395	0,8	MR 3I 126 - 38 x 300	132 MC 4	54,8	66,3	152	1,7	MR 3I 125 - 38 x 300	132 MC 4	21,1		
25,6		393	1,25	MR 3I 140 - 42 x 350	160 L 6	35,1	66,3	152	2,24	MR 3I 126 - 38 x 300	132 MC 4	21,1		
25,8		390	0,9	MR 3I 126 - 42 x 350	160 L 6	34,8	67,4	150	0,85	MR 3I 100 - 38 x 300	132 MC 4	20,8		
							67,4	150	1,12	MR 3I 101 - 38 x 300	132 MC 4	20,8		
							68,6	147	3,15	MR 3I 140 - 42 x 350	160 M 4	20,4		
							69,1	149	1,4	MR 2I 125 - 42 x 350	160 M 4	20,3		

Motor (cat. TX) with efficiency value not according to IE3 class (IEC 60034-30); the nominal power and nameplate data refer to intermittent duty S3 70%.

1) Powers valid for continuous duty S1; increase possible for S2... S10 (ch. 2b) in which case P_2 and M_2 increase and f_s decreases proportionately.
2) For complete designation when ordering, see ch. 3.

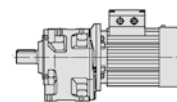

P_1 kW	n_2 min ⁻¹	M_2 daNm	f_s	Riduttore - Motore Gear reducer - Motor	i	P_1 kW	n_2 min ⁻¹	M_2 daNm	f_s	Riduttore - Motore Gear reducer - Motor	i
1)				2)		1)				2)	
15	75,9	181	2,36	MR 3I 140 - 42 x 350 160 L	4	18,5	46,3	366	2,65	MR 3I 180 - 48 x 350 180 M	4
	76,2	180	1,4	MR 3I 125 - 42 x 350 160 L	4		47,6	356	1,25	MR 3I 140 - 48 x 350 180 M	4
	76,2	180	1,9	MR 3I 126 - 42 x 350 160 L	4		48,1	353	0,85	MR 3I 126 - 48 x 350 180 M	4
	78,3	179	2,36	MR 2I 140 - 48 x 350 180 L	6		51,3	331	3	MR 3I 180 - 48 x 350 180 M	4
	79,1	178	1,32	MR 2I 125 - 48 x 350 180 L	6		52,6	323	1,4	MR 3I 140 - 48 x 350 180 M	4
	79,1	178	1,7	MR 2I 126 - 48 x 350 180 L	6		53,2	319	2,12	MR 3I 160 - 48 x 350 180 M	4
	80,8	174	3,35	MR 2I 160 - 42 x 350 160 L	4		53,6	317	0,8	MR 3I 125 - 48 x 350 180 M	4
	84,7	162	1,6	MR 3I 125 - 42 x 350 160 L	4		53,6	317	1,06	MR 3I 126 - 48 x 350 180 M	4
	84,7	162	2,12	MR 3I 126 - 42 x 350 160 L	4		58,8	288	1,7	MR 3I 140 - 48 x 350 180 M	4
	88	159	2	MR 2I 126 - 48 x 350 180 L	6		59,3	286	0,9	MR 3I 125 - 48 x 350 180 M	4
	88,2	159	1,4	MR 2I 125 - 42 x 350 160 L	4		59,3	286	1,18	MR 3I 126 - 48 x 350 180 M	4
	88,2	159	1,7	MR 2I 126 - 42 x 350 160 L	4		59,3	286	2,36	MR 3I 160 - 48 x 350 180 M	4
	88,2	159	2,5	MR 2I 140 - 42 x 350 160 L	4		65,2	260	0,95	MR 3I 125 - 48 x 350 180 M	4
	98	143	3	MR 2I 140 - 42 x 350 160 L	4		65,2	260	1,32	MR 3I 126 - 48 x 350 180 M	4
	99	142	1,7	MR 2I 125 - 42 x 350 160 L	4		68,2	249	2,8	MR 3I 160 - 48 x 350 180 M	4
	99	142	2,12	MR 2I 126 - 42 x 350 160 L	4		68,6	247	1,9	MR 3I 140 - 48 x 350 180 M	4
	110	127	1,9	MR 2I 125 - 42 x 350 160 L	4		73,9	234	2,36	MR 2I 160 - 48 x 350 180 M	4
	110	127	2,5	MR 2I 126 - 42 x 350 160 L	4		75,9	223	2	MR 3I 140 - 48 x 350 180 M	4
	114	123	0,9	MR 2I 100 - 42 x 350 160 L	4		76,2	223	1,12	MR 3I 125 - 48 x 350 180 M	4
	114	123	1,12	MR 2I 101 - 42 x 350 160 L	4		76,2	223	1,5	MR 3I 126 - 48 x 350 180 M	4
	123	114	2	MR 2I 125 - 42 x 350 160 L	4		80,8	214	2,8	MR 2I 160 - 48 x 350 180 M	4
	123	114	2,5	MR 2I 126 - 42 x 350 160 L	4		84,7	200	1,25	MR 3I 125 - 48 x 350 180 M	4
	126	111	1,06	MR 2I 100 - 42 x 350 160 L	4		84,7	200	1,7	MR 3I 126 - 48 x 350 180 M	4
	126	111	1,32	MR 2I 101 - 42 x 350 160 L	4		85,8	202	1	MR 2I 125 - 48 x 350 180 M	4
	137	103	2,36	MR 2I 125 - 42 x 350 160 L	4		88	197	3,15	MR 2I 160 - 48 x 350 180 M	4
	137	103	3	MR 2I 126 - 42 x 350 160 L	4		100	173	2,36	MR 2I 140 - 55 x 400 200 LR	6
	140	101	1,18	MR 2I 100 - 42 x 350 160 L	4		101	171	1,4	MR 2I 125 - 55 x 400 200 LR	6
	140	101	1,5	MR 2I 101 - 42 x 350 160 L	4		101	171	1,7	MR 2I 126 - 55 x 400 200 LR	6
	152	93	2,5	MR 2I 125 - 42 x 350 160 L	4		101	172	3,75	MR 2I 160 - 48 x 350 180 M	4
	162	87	1,32	MR 2I 100 - 42 x 350 160 L	4		110	158	1,4	MR 2I 125 - 48 x 350 180 M	4
	162	87	1,6	MR 2I 101 - 42 x 350 160 L	4		110	158	1,7	MR 2I 126 - 48 x 350 180 M	4
	167	84	2,8	MR 2I 125 - 42 x 350 160 L	4		110	158	2,5	MR 2I 140 - 48 x 350 180 M	4
	178	79	1,5	MR 2I 100 - 42 x 350 160 L	4		122	142	3	MR 2I 140 - 48 x 350 180 M	4
	178	79	1,9	MR 2I 101 - 42 x 350 160 L	4		123	141	1,6	MR 2I 125 - 48 x 350 180 M	4
	195	72	3,35	MR 2I 125 - 42 x 350 160 L	4		123	141	2,12	MR 2I 126 - 48 x 350 180 M	4
	196	72	1,6	MR 2I 100 - 42 x 350 160 L	4		137	126	1,9	MR 2I 125 - 48 x 350 180 M	4
	196	72	2,24	MR 2I 101 - 42 x 350 160 L	4		137	126	2,5	MR 2I 126 - 48 x 350 180 M	4
	214	66	1,8	MR 2I 100 - 42 x 350 160 L	4		145	119	0,9	MR 2I 100 - 48 x 350 180 M	4
	214	66	2,36	MR 2I 101 - 42 x 350 160 L	4		145	119	1,12	MR 2I 101 - 48 x 350 180 M	4
	217	65	3,75	MR 2I 125 - 42 x 350 160 L	4		152	114	2,12	MR 2I 125 - 48 x 350 180 M	4
	248	57	2,12	MR 2I 100 - 42 x 350 160 L	4		152	114	2,8	MR 2I 126 - 48 x 350 180 M	4
	248	57	2,65	MR 2I 101 - 42 x 350 160 L	4		162	107	1,06	MR 2I 100 - 48 x 350 180 M	4
274	51	2,24	MR 2I 100 - 42 x 350 160 L	4	162	107	1,32	MR 2I 101 - 48 x 350 180 M	4		
274	51	2,65	MR 2I 101 - 42 x 350 160 L	4	167	104	2,24	MR 2I 125 - 48 x 350 180 M	4		
342	41,1	2,36	MR 2I 100 - 42 x 350 160 L	4	167	104	3	MR 2I 126 - 48 x 350 180 M	4		
18,5	20,7	821	1,12	MR 3I 180 - 48 x 350 180 M	4	178	97	1,18	MR 2I 100 - 48 x 350 180 M	4	
	20,8	817	0,85	MR 3I 160 - 48 x 350 180 M	4	178	97	1,6	MR 2I 101 - 48 x 350 180 M	4	
	23,5	722	1,25	MR 3I 180 - 48 x 350 180 M	4	195	89	2,65	MR 2I 125 - 48 x 350 180 M	4	
	24,3	697	0,9	MR 3I 160 - 48 x 350 180 M	4	196	88	1,32	MR 2I 100 - 48 x 350 180 M	4	
	24,9	681	1,06	MR 3I 160 - 55 x 400 200 LR	6	196	88	1,8	MR 2I 101 - 48 x 350 180 M	4	
	26,4	643	1,5	MR 3I 180 - 48 x 350 180 M	4	214	81	1,4	MR 2I 100 - 48 x 350 180 M	4	
	26,4	640	1,06	MR 3I 160 - 48 x 350 180 M	4	214	81	2	MR 2I 101 - 48 x 350 180 M	4	
	28,7	590	1,18	MR 3I 160 - 55 x 400 200 LR	6	217	80	3	MR 2I 125 - 48 x 350 180 M	4	
	30,3	560	1,25	MR 3I 160 - 48 x 350 180 M	4	248	70	1,7	MR 2I 100 - 48 x 350 180 M	4	
	30,4	557	1,7	MR 3I 180 - 48 x 350 180 M	4	248	70	2,12	MR 2I 101 - 48 x 350 180 M	4	
	32,3	525	0,85	MR 3I 140 - 48 x 350 180 M	4	274	63	1,9	MR 2I 100 - 48 x 350 180 M	4	
	33	514	1,9	MR 3I 180 - 48 x 350 180 M	4	274	63	2,12	MR 2I 101 - 48 x 350 180 M	4	
	35	485	1,4	MR 3I 160 - 48 x 350 180 M	4	342	51	1,9	MR 2I 100 - 48 x 350 180 M	4	
	35,6	476	1	MR 3I 140 - 48 x 350 180 M	4	342	51	2,12	MR 2I 101 - 48 x 350 180 M	4	
	35,7	475	1,9	MR 3I 180 - 48 x 350 180 M	4	22	19,3	1046	0,9	MR 3I 180 - 55 x 400 200 L	6
	39,9	425	1,12	MR 3I 140 - 48 x 350 180 M	4	20,7	976	0,95	MR 3I 180 - 48 x 350 180 L	4	
	40,1	423	2,24	MR 3I 180 - 48 x 350 180 M	4	21,7	931	1,06	MR 3I 180 - 55 x 400 200 L	6	
	40,2	422	0,8	MR 3I 126 - 48 x 350 180 M	4	23,5	859	1,06	MR 3I 180 - 48 x 350 180 L	4	
	40,3	420	1,6	MR 3I 160 - 48 x 350 180 M	4	24,3	828	0,8	MR 3I 160 - 48 x 350 180 L	4	
	43,8	388	1,18	MR 3I 140 - 48 x 350 180 M	4	24,9	810	0,9	MR 3I 160 - 55 x 400 200 L	6	
	44,2	384	0,9	MR 3I 126 - 48 x 350 180 M	4	26,4	765	1,25	MR 3I 180 - 48 x 350 180 L	4	
	46,1	368	1,9	MR 3I 160 - 48 x 350 180 M	4	26,5	761	0,9	MR 3I 160 - 48 x 350 180 L	4	

1) Powers valid for continuous duty S1; **Increase** possible for S2... S10 (ch. 2b) in which case P_2 and M_2 increase and f_s decreases proportionately.
 2) For complete designation when ordering, see ch. 3.

Gearmotors selection tables

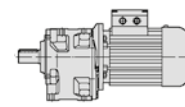

3.7

P_1 kW	n_2 min ⁻¹	M_2 daN m	f_s	Riduttore - Motore Gear reducer - Motor	i	P_1 kW	n_2 min ⁻¹	M_2 daN m	f_s	Riduttore - Motore Gear reducer - Motor	i	
1)				2)		1)				2)		
22	27,1	745	1,32	MR 3I 180 - 55 x 400 200 L	6	22	195	106	2,24	MR 2I 125 - 48 x 350 180 L	4	
	28,7	702	1	MR 3I 160 - 55 x 400 200 L	6		195	106	3	MR 2I 126 - 48 x 350 180 L	4	
	30,3	666	1,06	MR 3I 160 - 48 x 350 180 L	4		217	95	2,5	MR 2I 125 - 48 x 350 180 L	4	
	30,4	663	1,4	MR 3I 180 - 48 x 350 180 L	4		274	75	2,65	MR 2I 125 - 48 x 350 180 L	4	
	33	612	1,6	MR 3I 180 - 48 x 350 180 L	4		30	30	917	1	MR 3I 180 - 55 x 400 200 L	4
	35	577	1,18	MR 3I 160 - 48 x 350 180 L	4			33,7	816	1,18	MR 3I 180 - 55 x 400 200 L	4
	35,6	566	0,85	MR 3I 140 - 48 x 350 180 L	4			38,7	710	0,95	MR 3I 160 - 55 x 400 200 L	4
	35,7	565	1,6	MR 3I 180 - 48 x 350 180 L	4			38,9	707	1,32	MR 3I 180 - 55 x 400 200 L	4
	39,9	506	0,95	MR 3I 140 - 48 x 350 180 L	4			42,1	653	1,4	MR 3I 180 - 55 x 400 200 L	4
	40,1	502	1,9	MR 3I 180 - 48 x 350 180 L	4			44,7	616	1,12	MR 3I 160 - 55 x 400 200 L	4
	40,3	500	1,32	MR 3I 160 - 48 x 350 180 L	4			45,7	602	1,5	MR 3I 180 - 55 x 400 200 L	4
	43,8	461	1	MR 3I 140 - 48 x 350 180 L	4			51,3	536	1,7	MR 3I 180 - 55 x 400 200 L	4
	46,1	437	1,6	MR 3I 160 - 48 x 350 180 L	4			51,5	534	1,25	MR 3I 160 - 55 x 400 200 L	4
	46,3	435	2,24	MR 3I 180 - 48 x 350 180 L	4			52,6	523	0,9	MR 3I 140 - 48 x 350 200 L	*
	47,6	424	1,06	MR 3I 140 - 48 x 350 180 L	4			58,8	468	1	MR 3I 140 - 48 x 350 200 L	*
	51,3	393	2,5	MR 3I 180 - 48 x 350 180 L	4			58,9	467	1,4	MR 3I 160 - 55 x 400 200 L	4
	52,6	384	1,18	MR 3I 140 - 48 x 350 180 L	4			59,2	465	2	MR 3I 180 - 55 x 400 200 L	4
	53,2	379	1,8	MR 3I 160 - 48 x 350 180 L	4			65,6	420	2,24	MR 3I 180 - 55 x 400 200 L	4
	53,6	376	0,85	MR 3I 126 - 48 x 350 180 L	4			68	405	1,7	MR 3I 160 - 55 x 400 200 L	4
	55,9	368	2,12	MR 2I 180 - 55 x 400 200 L	6			68,6	401	1,18	MR 3I 140 - 48 x 350 200 L	*
	57,6	357	1,6	MR 2I 160 - 55 x 400 200 L	6			75,2	366	2,36	MR 3I 180 - 55 x 400 200 L	4
	58,8	343	1,4	MR 3I 140 - 48 x 350 180 L	4			75,7	363	1,9	MR 3I 160 - 55 x 400 200 L	4
	58,8	343	2,65	MR 3I 180 - 48 x 350 180 L	4			75,9	362	1,18	MR 3I 140 - 48 x 350 200 L	*
	59,3	340	1	MR 3I 126 - 48 x 350 180 L	4			87	323	2,36	MR 2I 180 - 55 x 400 200 L	4
	59,3	340	2	MR 3I 160 - 48 x 350 180 L	4			87,2	316	2,12	MR 3I 160 - 55 x 400 200 L	4
	60,8	339	2,5	MR 2I 180 - 55 x 400 200 L	6			89,6	313	1,8	MR 2I 160 - 55 x 400 200 L	4
	63	327	1,9	MR 2I 160 - 55 x 400 200 L	6			94,5	297	2,8	MR 2I 180 - 55 x 400 200 L	4
	65,2	309	0,8	MR 3I 125 - 48 x 350 180 L	4			98	286	2	MR 2I 160 - 55 x 400 200 L	4
	65,2	309	1,12	MR 3I 126 - 48 x 350 180 L	4			106	264	3,35	MR 2I 180 - 55 x 400 200 L	4
	68,2	296	2,36	MR 3I 160 - 48 x 350 180 L	4			107	263	2,36	MR 2I 160 - 55 x 400 200 L	4
	68,6	294	1,6	MR 3I 140 - 48 x 350 180 L	4			110	256	0,85	MR 2I 125 - 55 x 400 200 L	4
	70,4	292	0,8	MR 2I 125 - 55 x 400 200 L	6			110	256	1,06	MR 2I 126 - 55 x 400 200 L	4
	70,4	292	0,95	MR 2I 126 - 55 x 400 200 L	6			110	256	1,5	MR 2I 140 - 55 x 400 200 L	4
	70,4	292	1,32	MR 2I 140 - 55 x 400 200 L	6			122	231	1,8	MR 2I 140 - 55 x 400 200 L	4
	71,7	287	2,8	MR 2I 180 - 48 x 350 180 L	4			122	230	2,8	MR 2I 160 - 55 x 400 200 L	4
	73,9	279	2	MR 2I 160 - 48 x 350 180 L	4			123	228	1	MR 2I 125 - 55 x 400 200 L	4
	75,9	266	1,6	MR 3I 140 - 48 x 350 180 L	4			123	228	1,25	MR 2I 126 - 55 x 400 200 L	4
	76,2	265	0,95	MR 3I 125 - 48 x 350 180 L	4			134	209	2,12	MR 2I 140 - 55 x 400 200 L	4
	76,2	265	1,25	MR 3I 126 - 48 x 350 180 L	4			137	205	1,18	MR 2I 125 - 55 x 400 200 L	4
	77,9	264	3,15	MR 2I 180 - 48 x 350 180 L	4			137	205	1,5	MR 2I 126 - 55 x 400 200 L	4
	80,8	255	2,36	MR 2I 160 - 48 x 350 180 L	4			141	199	3,15	MR 2I 160 - 55 x 400 200 L	4
	84,7	238	1,06	MR 3I 125 - 48 x 350 180 L	4			156	180	2,24	MR 2I 140 - 55 x 400 200 L	4
	84,7	238	1,4	MR 3I 126 - 48 x 350 180 L	4			157	179	1,25	MR 2I 125 - 55 x 400 200 L	4
	85,8	240	0,85	MR 2I 125 - 48 x 350 180 L	4			157	179	1,6	MR 2I 126 - 55 x 400 200 L	4
	86,4	238	1,9	MR 2I 140 - 55 x 400 200 L	6			172	164	2,65	MR 2I 140 - 55 x 400 200 L	4
	88	234	1,06	MR 2I 125 - 55 x 400 200 L	6			175	160	1,5	MR 2I 125 - 55 x 400 200 L	4
	88	234	1,32	MR 2I 126 - 55 x 400 200 L	6			175	160	1,9	MR 2I 126 - 55 x 400 200 L	4
	88	234	2,65	MR 2I 160 - 48 x 350 180 L	4			192	146	2,65	MR 2I 140 - 55 x 400 200 L	4
	100	206	2	MR 2I 140 - 55 x 400 200 L	6			194	145	1,6	MR 2I 125 - 55 x 400 200 L	4
	101	204	1,12	MR 2I 125 - 55 x 400 200 L	6			194	145	2,12	MR 2I 126 - 55 x 400 200 L	4
101	204	1,4	MR 2I 126 - 55 x 400 200 L	6	213	132		1,8	MR 2I 125 - 55 x 400 200 L	4		
101	205	3,15	MR 2I 160 - 48 x 350 180 L	4	213	132		2,36	MR 2I 126 - 55 x 400 200 L	4		
110	188	1,18	MR 2I 125 - 48 x 350 180 L	4	224	125		2,65	MR 2I 140 - 55 x 400 200 L	4		
110	188	1,4	MR 2I 126 - 48 x 350 180 L	4	249	113		2,12	MR 2I 125 - 55 x 400 200 L	4		
110	187	2,36	MR 2I 140 - 55 x 400 200 L	6	249	113	2,65	MR 2I 126 - 55 x 400 200 L	4			
110	188	2	MR 2I 140 - 48 x 350 180 L	4	277	101	2,36	MR 2I 125 - 55 x 400 200 L	4			
113	183	1,32	MR 2I 125 - 55 x 400 200 L	6	277	101	2,65	MR 2I 126 - 55 x 400 200 L	4			
113	183	1,7	MR 2I 126 - 55 x 400 200 L	6	350	80	2,5	MR 2I 125 - 55 x 400 200 L	4			
116	177	3,75	MR 2I 160 - 48 x 350 180 L	4	37	30	1131	0,8	MR 3I 180 - 60 x 450 225 S	4		
122	169	2,5	MR 2I 140 - 48 x 350 180 L	4		33,7	1006	0,95	MR 3I 180 - 60 x 450 225 S	4		
123	167	1,4	MR 2I 125 - 48 x 350 180 L	4		38,7	876	0,8	MR 3I 160 - 60 x 450 225 S	4		
123	167	1,7	MR 2I 126 - 48 x 350 180 L	4		38,9	872	1,06	MR 3I 180 - 60 x 450 225 S	4		
124	165	2	MR 2I 126 - 55 x 400 200 L	6		42,1	805	1,18	MR 3I 180 - 60 x 450 225 S	4		
134	153	2,8	MR 2I 140 - 48 x 350 180 L	4		44,7	759	0,9	MR 3I 160 - 60 x 450 225 S	4		
137	150	1,6	MR 2I 125 - 48 x 350 180 L	4		45,7	743	1,18	MR 3I 180 - 60 x 450 225 S	4		
137	150	2	MR 2I 126 - 48 x 350 180 L	4								
152	136	1,8	MR 2I 125 - 48 x 350 180 L	4								
152	136	2,36	MR 2I 126 - 48 x 350 180 L	4								
167	123	1,9	MR 2I 125 - 48 x 350 180 L	4								
167	123	2,65	MR 2I 126 - 48 x 350 180 L	4								

1) Powers valid for continuous duty S1; increase possible for S2 ... S10 (ch. 2b) in which case M_2 increases and f_s decreases proportionately.

2) For complete designation when ordering, see ch. 3.

* Mounting position **B5R** (see table ch. 2b).

* In case of ambient temperature > 30 °C check the thermal power (ch. 4).

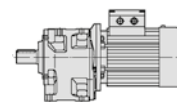

P_1 kW	n_2 min ⁻¹	M_2 daN m	f_s	Riduttore - Motore Gear reducer - Motor	i	
1)	2)					
37	51,3	661	1,4	MR 3I 180 - 60 x 450 225 S	4 27,3	
	51,5	658	1	MR 3I 160 - 60 x 450 225 S	4 27,2	
	58,9	576	1,18	MR 3I 160 - 60 x 450 225 S	4 23,8	
	59,2	573	1,7	MR 3I 180 - 60 x 450 225 S	4 23,7	
	65,6	517	1,8	MR 3I 180 - 60 x 450 225 S	4 21,4	
	68	499	1,32	MR 3I 160 - 60 x 450 225 S	4 20,6	
	75,2	451	1,9	MR 3I 180 - 60 x 450 225 S	4 18,6	
	75,7	448	1,5	MR 3I 160 - 60 x 450 225 S	4 18,5	
	87,2	389	1,7	MR 3I 160 - 60 x 450 225 S	4 16,1	
	106	325	2,36	MR 2I 180 - 60 x 450 225 S	4 13,1	
	110	316	1,7	MR 2I 160 - 60 x 450 225 S	4 12,8	
	116	299	2,8	MR 2I 180 - 60 x 450 225 S	4 12,1	
	120	289	2	MR 2I 160 - 60 x 450 225 S	4 11,7	
	130	266	3,15	MR 2I 180 - 60 x 450 225 S	4 10,8	
	131	265	2,36	MR 2I 160 - 60 x 450 225 S	4 10,7	
	*	140	247	1,5	MR 2I 140 - 60 x 450 225 S	4 10
	*	149	232	2,8	MR 2I 160 - 60 x 450 225 S	4 9,37
	*	150	231	3,15	MR 2I 180 - 60 x 450 225 S	4 9,33
	*	156	223	1,8	MR 2I 140 - 60 x 450 225 S	4 9
	*	172	202	2,12	MR 2I 140 - 60 x 450 225 S	4 8,15
*	172	201	3,15	MR 2I 160 - 60 x 450 225 S	4 8,12	
*	192	180	2,12	MR 2I 140 - 60 x 450 225 S	4 7,29	
*	224	155	2,12	MR 2I 140 - 60 x 450 225 S	4 6,25	
*	248	140	2,12	MR 2I 140 - 60 x 450 225 S	4 5,65	
45	33,7	1224	0,8	MR 3I 180 - 60 x 450 225 M	4 41,5	
	38,9	1061	0,9	MR 3I 180 - 60 x 450 225 M	4 36	
	42,1	979	0,95	MR 3I 180 - 60 x 450 225 M	4 33,2	
	45,7	904	0,95	MR 3I 180 - 60 x 450 225 M	4 30,7	
	51,3	804	1,18	MR 3I 180 - 60 x 450 225 M	4 27,3	
	51,5	800	0,8	MR 3I 160 - 60 x 450 225 M	4 27,2	
	58,9	700	0,95	MR 3I 160 - 60 x 450 225 M	4 23,8	
	59,2	697	1,4	MR 3I 180 - 60 x 450 225 M	4 23,7	
	65,6	629	1,5	MR 3I 180 - 60 x 450 225 M	4 21,4	
	68	607	1,12	MR 3I 160 - 60 x 450 225 M	4 20,6	
	75,2	549	1,6	MR 3I 180 - 60 x 450 225 M	4 18,6	
	75,7	545	1,25	MR 3I 160 - 60 x 450 225 M	4 18,5	
	87,2	473	1,4	MR 3I 160 - 60 x 450 225 M	4 16,1	
	106	396	2	MR 2I 180 - 60 x 450 225 M	4 13,1	
	110	384	1,4	MR 2I 160 - 60 x 450 225 M	4 12,8	
	116	364	2,24	MR 2I 180 - 60 x 450 225 M	4 12,1	
	120	351	1,7	MR 2I 160 - 60 x 450 225 M	4 11,7	
	130	324	2,65	MR 2I 180 - 60 x 450 225 M	4 10,8	

P_1 kW	n_2 min ⁻¹	M_2 daN m	f_s	Riduttore - Motore Gear reducer - Motor	i		
1)	2)						
45	131	322	1,9	MR 2I 160 - 60 x 450 225 M	4 10,7		
	*	140	301	1,25	MR 2I 140 - 60 x 450 225 M	4 10	
	*	149	282	2,24	MR 2I 160 - 60 x 450 225 M	4 9,37	
	*	150	281	2,65	MR 2I 180 - 60 x 450 225 M	4 9,33	
	*	156	271	1,5	MR 2I 140 - 60 x 450 225 M	4 9	
	*	172	245	1,7	MR 2I 140 - 60 x 450 225 M	4 8,15	
	*	172	244	2,65	MR 2I 160 - 60 x 450 225 M	4 8,12	
	*	192	219	1,7	MR 2I 140 - 60 x 450 225 M	4 7,29	
	*	192	219	2,65	MR 2I 160 - 60 x 450 225 M	4 7,29	
	*	221	191	2,65	MR 2I 160 - 60 x 450 225 M	4 6,34	
	*	224	188	1,7	MR 2I 140 - 60 x 450 225 M	4 6,25	
	*	248	170	1,7	MR 2I 140 - 60 x 450 225 M	4 5,65	
	55	**	42,1	1197	0,8	MR 3I 180 - 60 x 450 250 M	* 4 33,2
		**	45,7	1105	0,8	MR 3I 180 - 60 x 450 250 M	* 4 30,7
		**	51,3	983	0,95	MR 3I 180 - 60 x 450 250 M	* 4 27,3
**		59,2	852	1,12	MR 3I 180 - 60 x 450 250 M	* 4 23,7	
**		65,6	769	1,25	MR 3I 180 - 60 x 450 250 M	* 4 21,4	
**		75,2	671	1,32	MR 3I 180 - 60 x 450 250 M	* 4 18,6	
*		106	483	1,6	MR 2I 180 - 65 x 550 250 M	4 13,1	
*		110	469	1,18	MR 2I 160 - 65 x 550 250 M	4 12,8	
*		116	445	1,9	MR 2I 180 - 65 x 550 250 M	4 12,1	
*		120	429	1,32	MR 2I 160 - 65 x 550 250 M	4 11,7	
*		130	396	2,12	MR 2I 180 - 65 x 550 250 M	4 10,8	
*		131	394	1,6	MR 2I 160 - 65 x 550 250 M	4 10,7	
*		149	345	1,9	MR 2I 160 - 65 x 550 250 M	4 9,37	
*		150	343	2,12	MR 2I 180 - 65 x 550 250 M	4 9,33	
*		166	310	2,12	MR 2I 180 - 65 x 550 250 M	4 8,43	
75	**	136	516	1,5	MR 2I 180 - 75 x 550 280 S	4 10,3	
	**	148	475	1,7	MR 2I 180 - 75 x 550 280 S	4 9,48	
	**	166	423	1,7	MR 2I 180 - 75 x 550 280 S	4 8,44	
	**	191	367	1,7	MR 2I 180 - 75 x 550 280 S	4 7,31	
	**	212	331	1,7	MR 2I 180 - 75 x 550 280 S	4 6,6	
	**	243	289	1,7	MR 2I 180 - 75 x 550 280 S	4 5,76	

1) Powers valid for continuous duty S1; **increase** possible for S2 ... S10 (ch. 2b) in which case M_2 increases and f_s decreases proportionately.

2) For complete designation when ordering, see ch. 3.

* Mounting position **B5R** (see table ch. 2b).

* In case of ambient temperature > 30 °C check the thermal power (ch. 4).

** Check the thermal power.

Designs, dimensions, mounting positions and lubricant quantities 3.8

blank page

Designs, dimensions, mounting positions and lubricant quantities 3.8

MR 2I, 3I 32 ... 41

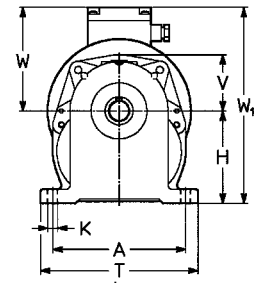
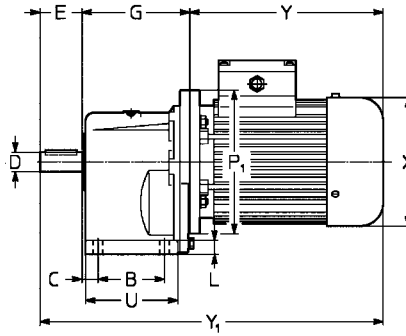
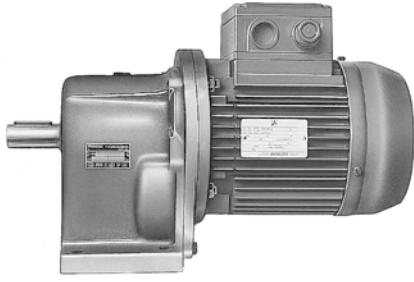

UTC 210

Standard design¹⁾

Mounting position B3, B6, B7, B8, V5, V6

PC1A

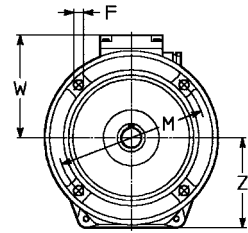
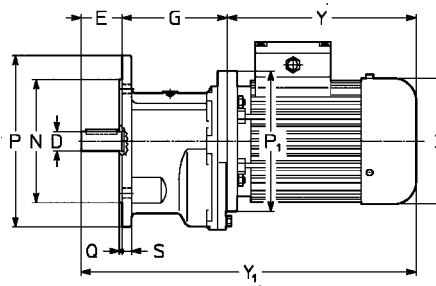
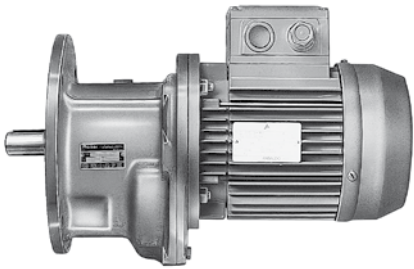

UTC 211

Standard design¹⁾

Mounting position B5, V1, V3

FC1A

Size red. motor	A	B	C	D ∅	E	F ∅	G	H h11	K ∅	L	M ∅	N ∅ h6	P ∅	Q	S	T	U	V Z	P ₁ ∅	X ∅ ≈	Y ≈	Y ₁ ≈	W ≈	W ₁ ≈	Mass kg	HB	HBZ			
	B5																								11)					
32	63	115	53	20	16	30	9,5	98-88 ⁵⁾	75	9,5	10	115	95	140	3	10	139	77	48	140	123	189	244	317	372	95	170	4	9	11
	71 ⁴⁾																		73	140	138	235	297	363	425	112	187	4	12	15
40	63	132	63	19	19	40	9,5	113	90	9,5	12	130	110	160	3,5	10	156	92	56	140	123	189	244	342	397	95	185	7	12	14
	71																		87	160	138	216	278	369	431	112	202	7	15	18
	80 ³⁾																		160	156	254	323	407	476	121	211	7	19	23	
41	63	132	63	34	24	36	9,5	128-113 ⁵⁾	90	9,5	12	130	110	160	3,5	10	156	92	56	140	123	189	244	353	408	95	185	7	12	14
	71																		87	160	138	216	278	380	442	112	202	7	15	18
	80 ³⁾																		160	156	254	323	418	487	121	211	7	19	23	

- 1) See ch. 3 for motor design.
- 2) Values valid for brake motor.
- 3) Mounting position B5A (see ch. 2b).
- 4) Mounting position B5R (see ch. 2b).
- 5) Dimensions of shaft end shoulder and flange surface respectively.
- 6) For size 51 Y₁ is -8 mm.
- 7) For motor shaft H is -15 mm, H₀ +15 mm.
- 8) For motor shaft H is -8 mm, H₀ +8 mm.
- 9) For motor shaft H is -29 mm, H₀ +29 mm.
- 10) Two of the motor flange holes are slotted (see ch. 2b).
- 11) Values valid for gearmotor without motor.
- 12) Brake motor cat. TX not possible.

Mounting positions and grease quantities [kg]

Design	Mounting positions						Size	Grease quantities [kg]	
	B3	B6	B7	B8	V5	V6		B3, B6 B7, B8	V5, V6
PC1A							32 40,41	0,14 0,26	0,25 0,47
FC1A							32 40,41	0,1 0,19	0,18 0,35

UTC 217

Designs, dimensions, mounting positions and lubricant quantities 3.8

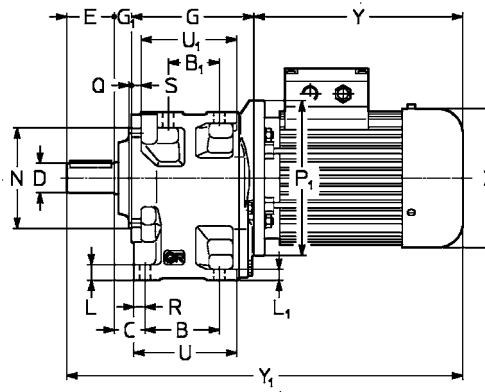
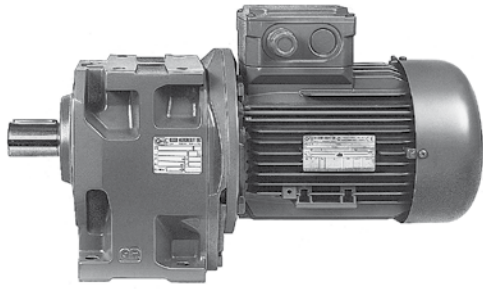

MR 2I, 3I 50 ... 180

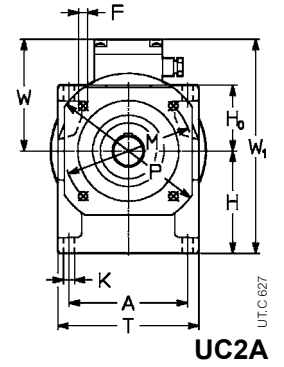

Standard design¹⁾

Mounting position B3, B6, B7, B8, V5, V6

Size	A	B	B1	C	D ∅	E	F ∅	G	G1	H h11	Hb h11	K ∅	L	L1	M ∅	N ∅ h6	P ∅	R	S	T	U	U1	P1 ∅	X ∅	Y		Y1		W	W1	Mass			
																									HB	HBZ	HB	HBZ			TX	kg		HB
50 51	124	76	52	30,5	24 (50) 28 (51)	50 (50) 42 (51)	9,5	128	16	106	71	11,5	17	12	130	110	160 3,5	13,5	10	148	110	100	140	123	189	244	383	438	95	201	12	17	19	
																							160	138	216	278	410	472	112	218	12	20	23	
																							200	156	233	302	427	496	121	227	12	24	28	
																							200	176	287	366	481	560	141	247	12	31	37	
																							200	194	337	-	531	-	151	257	12	38	-	
63 64	153	96	66	36,5	32 (63) 38 (64)	58	11,5	158	19	132	85	14	20	14	165	130	200 3,5	16	12	182	136	124	160	138	216	278	451	513	112	244	20	28	31	
																							200	156	233	302	468	537	121	253	20	32	36	
																							200	176	287	366	522	601	141	273	20	39	45	
																							250	194	310	405	545	640	151	283	20	46	52	
																							250	218	336	435	571	670	163	295	20	55	64	
80 81	192	123	87	43	38 (80) 48 (81)	80	14	197	22	160	106	16	24	17	215	180	250 4	19	14	226	171	157	200	156	233	302	532	601	121	281	35	47	51	
																							200	176	287	366	586	665	141	301	35	54	60	
																							250	194	310	405	609	704	151	311	35	61	67	
																							250	218	336	435	635	734	163	323	35	70	79	
																							300	257	445	553	747	855	194	354	35	104	116	
100 101	240	160	119	51,5	48 (100) 55 (101)	82	14	242	27	195	132	18	28,5	20	265	230	300 4	22,5	16	280	214	198	200	176	287	366	638	717	141	336	62	81	87	
																							250	194	310	405	661	756	151	346	62	88	94	
																							250	218	336	435	687	786	163	358	62	97	106	
																							300	257	445	553	796	904	194	389	62	131	143	
																							350	315	540	630	907	997	240	435	62	185	222	
125 126	297	200	151	59	60 (125) 70 (126)	105	18	297	30	236	160	22	35	25	300	250	350 5	26,5	19	345	264	245	250	194	310	405	742	837	151	396	110	136	142	
																							250	218	336	435	768	867	163	399	110	145	154	
																							300	257	445	553	877	985	194	430	110	179	191	
																							350	315	540	630	972	1062	240	476	110	233	270	
																							350	360	590	725	1022	1157	278	514	110	350	398	
140	297	218	169	59	80	130	18	315	30	250 7)	160 7)	22	35	25	300	250	350 5	26,5	19	345	282	263	250	194	310	405	785	880	151	410	123	149	155	
																							250	218	336	435	811	910	163	410	123	158	167	
																							300	257	445	553	920	1028	194	429	123	192	204	
																							350	315	540	630	1015	1105	240	475	123	246	283	
																							350	360	590	725	1065	1200	278	513	123	363	411	
160	373	250	191	68,5	90	130	22	366	34	295 8)	200 8)	27	42	30	400	350	450 5	31,5	22	430	326	304	300	257	445	553	975	1083	194	495	195	264	276	
																							350	315	540	630	1070	1160	240	527	195	318	355	
																							350	360	590	725	1120	1255	278	565	195	435	483	
																							400	400	650	760	1180	1290	310	597	195	430	478	
																							450	450	680	-	1212	-	330	617	195	525	-	
180	373	275	216	68,5	100	165	22	391	34	315 9)	200 9)	27	42	30	400	350	450 5	31,5	22	430	351	329	300	257	445	553	1035	1143	194	515	218	287	299	
																							350	315	540	630	1130	1220	240	526	218	341	378	
																							350	360	590	725	1180	1315	278	564	218	458	506	
																							400	400	650	760	1240	1350	310	596	218	453	501	
																							450	450	680	-	1272	-	330	616	218	548	-	
550	485	736	-	1340	-	375	661	218	691	-																								
550	550	928	-	1532	-	405	691	218	900	-																								

See notes on page 62

Mounting positions and oil quantities [1]

B3	B6	B7	B8	V5	V6	Size	B3	B6, B7	B8, V6	V5
						50, 51	0,8	1,1	1,1	1,4
						63, 64	1,6	2,2	2,2	2,8
						80, 81	3,1	4,3	4,3	5,5
						100, 101	5,6	7,1	8	10
						125, 126	10,2	13,1	14,6	18,3
						140	11,6	14,8	16,6	21
						160	19,6	25	28	35
						180	23	29	32	40

Nominal torques for final gear reducer

M_{N2} [daN m] for $n_2 \leq 11,2 \text{ min}^{-1}$ ³⁾	η_{final}	i_{final}	Final gear reducer	+	Initial gear reducer or gearmotor
33,5	0,94	30	MR 3I 63-19×160 - 30¹⁾	+	R 2I or MR 2I, 3I 40
45		30	MR 3I 64-19×160 - 30¹⁾	+	R 2I or MR 2I, 3I 40
67		32,8	MR 3I 80-19×160 - 32,8¹⁾	+	R 2I or MR 2I, 3I 40
90		49,8	MR 3I 81-19×160 - 49,8¹⁾	+	R 2I or MR 2I, 3I 40
132		32	MR 3I 100-24×200 - 32	+	R 2I, 3I or MR 2I, 3I 50²⁾
180		53,1	MR 3I 101-24×200 - 53,1	+	R 2I, 3I or MR 2I, 3I 50²⁾
265		34,1	MR 3I 125-28×250 - 34,1	+	R 2I, 3I or MR 2I, 3I 63²⁾
355		50,2	MR 3I 126-28×250 - 50,2	+	R 2I, 3I or MR 2I, 3I 63²⁾
500		55,7	MR 3I 140-28×250 - 55,7	+	R 2I, 3I or MR 2I, 3I 63²⁾
710		49,7	MR 3I 160-38×300 - 49,7	+	R 2I, 3I or MR 2I, 3I 80²⁾
1 000		57,1	MR 3I 180-38×300 - 57,1	+	R 2I, 3I or MR 2I, 3I 80²⁾

For initial gear reducer or gearmotor performance data see ch. 3.5 and 3.7.

1) Final gearmotor has a 160 mm motor mounting flange (see dimension P_0 ch. 3.8).

2) Gear reducer in design «Oversized B5 flange» (see ch. 5); moreover, size 63 has the low speed shaft reduced to 28 mm: «Oversized B5 flange - Ø 28».

3) Provided that f_s is always $\geq 0,8$, it can be reduced by **1,06** for $n_2 = 2,8 \rightarrow 0,71 \text{ min}^{-1}$, by **1,12** for $n_2 \leq 0,71 \text{ min}^{-1}$.

Combined unit dimensions ¹⁾

3.10

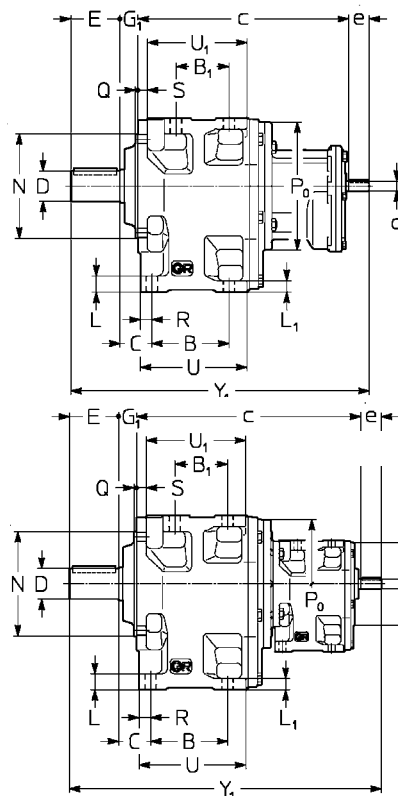

MR 3I 63 ... 81 + R 2I, 3I ...

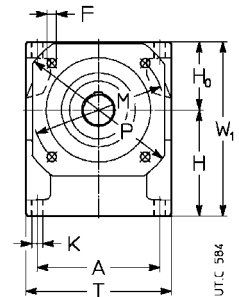

MR 3I 100 ... 180 + R 2I, 3I ...

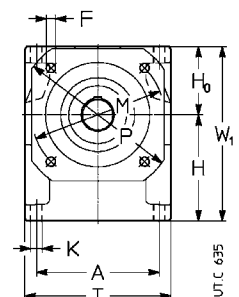

1) For design, mounting position and lubricant quantity of single gear reducers, see ch. 3.6 and 3.8.

Notes of page 65.

1) For high speed shaft or motor shaft H is -15 mm, H_0 +15 mm.

2) For high speed shaft or motor shaft H is -8 mm, H_0 +8 mm.

3) For high speed shaft or motor shaft H is -29 mm, H_0 +29 mm.

4) Values valid for brake motor.

5) Values valid for gearmotor without motor.

Combined unit dimensions

3.10

Gear reducer size		A	B	C	c	D	E	d	Y ₁	d	Y ₁	d	Y ₁	F	G ₁	H	K	L	M	N	P	P ₀	P ₁	R	S	T	U	W ₁	Mass		
final	initial	B ₁				∅		∅		∅		∅		∅		h ₁₁	∅	L ₁	∅	∅	∅	∅	∅	∅	∅	∅	∅	∅	∅	kg	
								R2I		R3I						H ₀					h ₆	Q ₀₊₂						U ₁			
								e h ₁ ≤ 12,5	e h ₁ ≥ 16	e h ₁ ≤ 80	e h ₁ ≥ 100																				
MR 3I 63 64	R 2I 40	153	96 66	36,5	280	32 38	58	11 23	380	11 23	380	—	—	—	11,5	19	132 85	14	20 14	165	130	200 3,5	160	—	16	12	182	136 124	217	27	
MR 3I 80 81	R 2I 40	192	123 87	43	319	38 48	80	11 23	444	11 23	444	—	—	—	14	22	160 106	16	24 17	215	180	250 4	160	—	19	14	226	171 157	266	42	
MR 3I 100 101	R 2I, 3I 50	240	160 119	51,5	396	48 55	82	14 30	535	14 30	535	11 23	528	11 23	528	14	27	195 132	18	28,5 20	265	230	300 4	200	140	22,5	16	280	214 198	327	74
MR 3I 125 126	R 2I, 3I 63	297	200 151	59	484	60 70	105	19 40	649	16 30	649	14 30	649	14 30	649	18	30	236 160	22	35 25	300	250	350 5	250	160	26,5	19	345	264 245	396	130
MR 3I 140	R 2I, 3I 63	297	218 169	59	502	80	130	11 23	692	16 30	692	14 30	692	14 30	692	18	30	250 ¹⁾ 160 ¹⁾	22	35 25	300	250	350 5	250	160	26,5	19	345	282 263	410	143
MR 3I 160	R 2I, 3I 80	373	250 191	68,5	596	90	130	11 23	800	19 40	800	19 40	800	16 30	790	22	34	295 ²⁾ 200 ²⁾	27	42 30	400	350	450 5	300	200	31,5	22	430	326 304	495	230
MR 3I 180	R 2I, 3I 80	373	275 216	68,5	621	100	165	11 23	800	19 40	860	19 40	860	16 30	850	22	34	315 ³⁾ 200 ³⁾	27	42 30	400	350	450 5	300	200	31,5	22	430	351 329	515	253

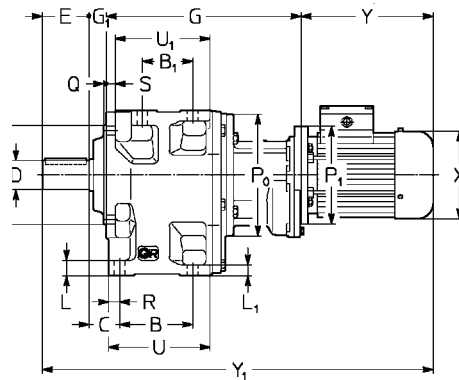

MR 3I 63 ... 81 + MR 2I, 3I ...

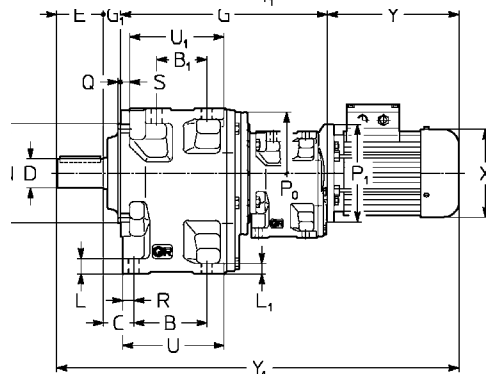
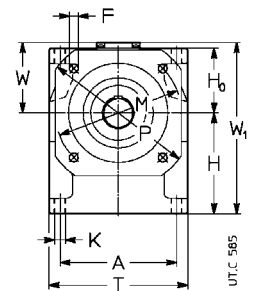

MR 3I 100 ... 180 + R 2I, 3I ...

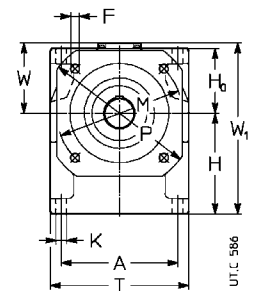

Size		A	B	C	D	E	F	G	G ₁	H	K	L	M	N	P	R	S	T	U	P ₀	P ₁	X	Y	Y ₁	W	W ₁	Mass	Mass				
gear reducer	motor				∅	∅	∅			h ₁₁	∅	L ₁	∅	h ₆	∅	∅	∅	∅	∅	∅	∅	∅					kg	kg				
final	initial	B ₁								H ₀		L ₁		h ₆	Q				U ₁													
															0+2								4)	4)	5)	4)						
MR 3I 63 64	MR 2I, 3I 40	63 71	153	96 66	36,5	32 (63) 38 (64)	58	11,5	271	19	132 85	14	20 14	165	130	200 3,5	16	12	182	136 124	160	140 160	123 138	189 216	244 278	537 564	592 626	95 112	227 244	27	32 35	34 38
MR 3I 80 81	MR 2I, 3I 40	63 71 80 ^{B5A}	192	123 87	43	38 (80) 48 (81)	80	14	310	22	160 106	16	24 17	215	180	250 4	19	14	226	171 157	160	140 160	123 156	189 216	244 278	601 628	656 690	95 112	266 272	42 42	47 50	49 53 58
MR 3I 100 101	MR 2I, 3I 50	63 71 80 90	240	160 119	51,5	48 (100) 55 (101)	82	14	386	27	195 132	18	28,5 20	265	230	300 4	22,5	16	280	214 198	200	140 160 200	123 138 156	189 216 233	244 278 302	684 711 728	739 773 797	95 112 121	327 327 327	74 74 74	79 82 86	81 85 90
MR 3I 125 126	MR 2I, 3I 63	71 80 90 100	297	200 151	59	60 (125) 70 (126)	105	18	474	30	236 160	22	35 25	300	250	350 5	26,5	19	345	264 245	250	160 200 200	138 156 176	216 233 287	278 302 366	825 842 896	887 911 975	112 121 141	396 396 396	130 130 130	138 142 149	141 154 155
MR 3I 140	MR 2I, 3I 63	71 80 90 100 112	297	218 169	59	80	130	18	492	30	250 160 1)	22	35 25	300	250	350 5	26,5	19	345	282 263	250	160 200 200	138 156 176	216 233 287	278 302 366	868 885 939	930 954 1018	112 121 141	410 410 410	143 143 143	151 154 162	154 159 168
MR 3I 160	MR 2I, 3I 80	80 90 100 112 132	373	250 191	68,5	90	130	22	585	34	295 200 2)	27	42 30	400	350	450 5	31,5	22	430	326 304	300	200 200 250	156 176 194	233 287 310	302 366 405	982 1036 1085	1051 1115 1184	121 141 163	495 495 495	230 249 265	242 255 274	246 269 285
MR 3I 180	MR 2I, 3I 80	80 90 100 112 132	373	275 216	68,5	100	165	22	610	37	315 200 3)	27	42 30	400	350	450 5	31,5	22	430	351 329	300	200 200 250	156 176 194	233 287 310	302 366 405	1045 1099 1122	1114 1178 1217	121 141 151	515 515 515	253 253 253	265 272 279	269 278 285

See notes on page 52.

Radial loads generated on the shaft end by a drive connecting gear reducer and motor must be less than or equal to those given in the relevant table.

The radial load F_{r1} given by the following formula refers to most common drives:

$$F_{r1} = \frac{2865 \cdot P_1}{d \cdot n_1} \text{ [daN]} \quad \text{for timing belt drive}$$

$$F_{r1} = \frac{4775 \cdot P_1}{d \cdot n_1} \text{ [daN]} \quad \text{for V-belt drive}$$

where: P_1 [kW] is power required at the input side of the gear reducer, n_1 [min^{-1}] is the speed, d [m] is the pitch diameter.

Radial loads given in the table are valid for overhung loads on centre line of high speed shaft end, i.e. operating at a distance of $0,5 \cdot e$ (e = shaft end length) from the shoulder. If they operate at $0,315 \cdot e$ multiply by 1,25; if they operate at $0,8 \cdot e$ multiply by 0,8.

n_1 [min^{-1}]	Gear reducer																		
	32		40		50			63			80			100, 101		125, 126, 140		160, 180	
	R 2I	R 2I	R 2I	R 2I	R 3I	R 2I	R 2I	R 3I	R 2I	R 2I	R 3I	R 2I	R 2I	R 3I	R 2I	R 3I	R 2I	R 3I	
1 400	11,2	17	42,5	26,5	17	67	42,5	26,5	106	67	42,5	170	67	265	170	425	265		
1 120	11,8	18	45	28	18	71	45	28	112	71	45	180	71	280	180	450	280		
900	12,5	19	47,5	30	19	75	47,5	30	118	75	47,5	190	75	300	190	475	300		
710	14	21,2	53	33,5	21,2	85	53	33,5	132	85	53	212	85	335	212	530	335		
560	15	22,4	56	35,5	22,4	90	56	35,5	140	90	56	224	90	355	224	560	355		
450	16	23,6	60	37,5	23,6	95	60	37,5	150	95	60	236	95	375	236	600	375		
355	18	26,5	67	42,5	26,5	106	67	42,5	170	106	67	265	106	425	265	670	425		

1) An axial load of up to 0,2 times the value in the table is permissible, simultaneously with the radial load. If exceeded consult us.

IMPORTANT: tabulated values for radial load F_{r1} can increase considerably in certain instances (direction of rotation, angular position of load, etc.). **Consult us** if need be.

Radial F_{r2} [daN] or axial loads F_{a2} [daN] on low speed shaft end 3.12

Axial loads F_{a2}

Permissible F_{a2} is shown in the column where direction of rotation of low speed shaft (black or white arrow) and direction of the axial force (solid or broken arrow) correspond to those of the gear reducer in question.

Wherever possible, choose the load conditions corresponding to the **column** with **highest** admissible values.

Radial loads F_{r2}

Radial loads generated on the shaft end by a drive connecting gear reducer and machine must be less than or equal to those given in the relevant table.

Normally, radial loads on low speed shaft ends are considerable: in fact there is a tendency to connect the gear reducer to the machine by means of a transmission with high transmission ratio (economizing on the gear reducer) and with small diameters (economizing on the drive, and for requirements dictated by overall dimensions).

Bearing life and wear (which also affect gears unfavourably) and low speed shaft strength, clearly impose limits on permissible radial load.

The high value which radial load may take on, and the importance of not exceeding permissible values, make it necessary to take full advantage of the gear reducer's possibilities.

Permissible radial loads given in the table are therefore based on: the product of speed n_2 [min^{-1}] multiplied by bearing life L_n [h] required, the direction of rotation, the angular position φ [$^\circ$] of the load and torque M_2 [daN m] required.

Radial loads given in the table are valid for overhung loads on centre line of low speed shaft end, i.e. operating at a distance of $0,5 \cdot E$ (E = shaft end length) from the shoulder. If operating at $0,315 \cdot E$ multiply by 1,25; if operating at $0,8 \cdot E$ multiply by 0,8.

Radial F_{r2} [daN] or axial loads F_{a2} [daN] on low speed shaft end 3.12

Radial load F_{r2} for most common drives has the following value and angular position:

$$F_{r2} = \frac{1\,910 \cdot P_2}{d \cdot n_2} \text{ [daN]}$$

for chain drive (lifting in general); for timing belt drive replace 1 910 with 2 865

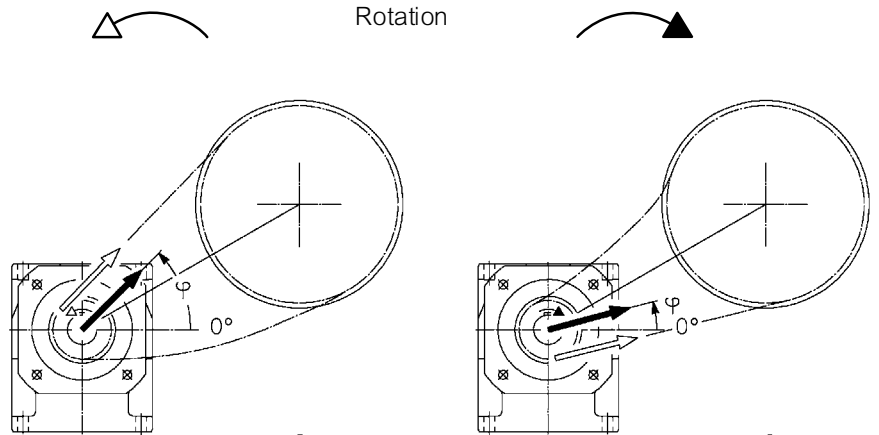

$$F_{r2} = \frac{4\,775 \cdot P_2}{d \cdot n_2} \text{ [daN]}$$

for V-belt drive

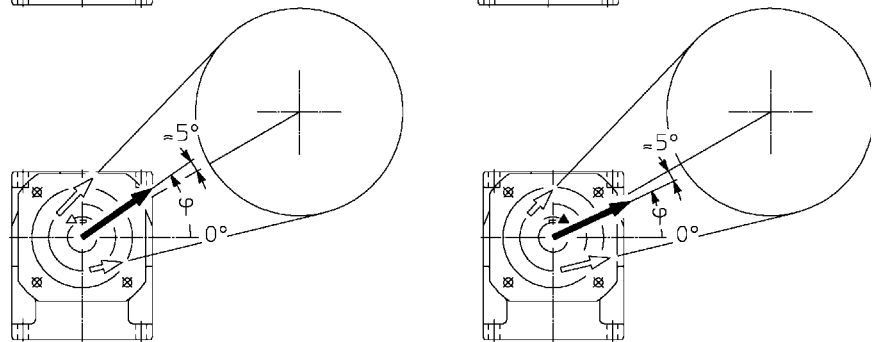

$$F_{r2} = \frac{2\,032 \cdot P_2}{d \cdot n_2} \text{ [daN]}$$

for spur gear pair drive

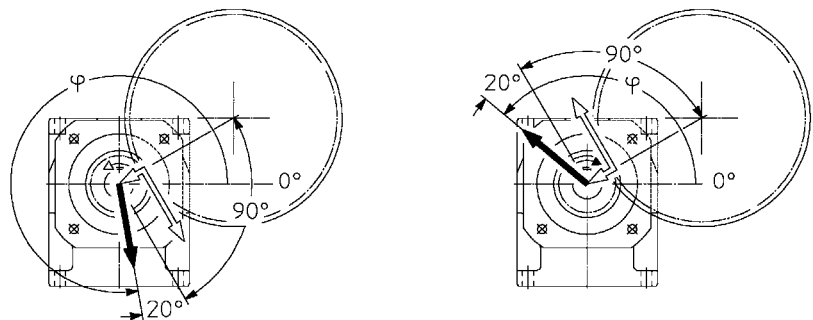

$$F_{r2} = \frac{6\,781 \cdot P_2}{d \cdot n_2} \text{ [daN]}$$

for friction wheel drive (rubber-on-metal)

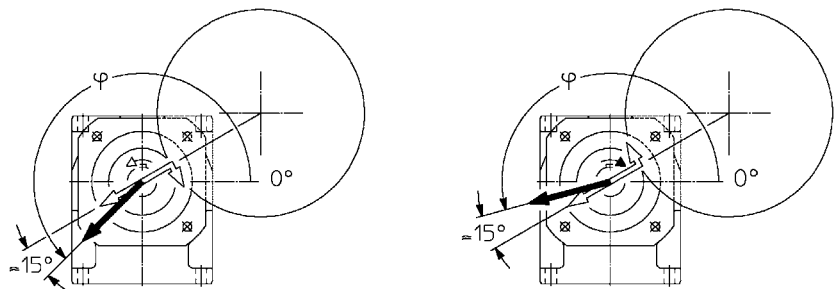

where: P_2 [kW] is power required at the output side of the gear reducer, n_2 [min^{-1}] is the speed, d [m] is the pitch diameter.

IMPORTANT: 0° coincides with a half line parallel to the bolted base of the housing as shown above, and therefore it follows the rotation of the housing, as shown below.

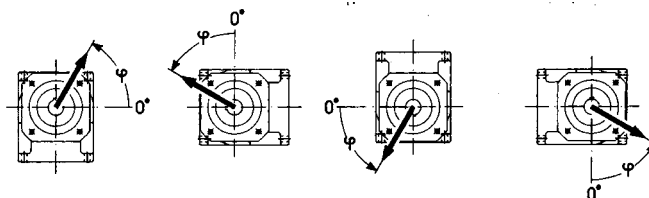

In the flanged design (sizes 32 ... 41), 0° remains in the same position, as per the same shape of the housing.

Radial F_{r2} [daN] or axial loads F_{a2} [daN] on low speed shaft end 3.12

size **32**

$n_2 \cdot L_1$ min ⁻¹ · h	M_2 daN m	$F_{r2}^{(1)}$																$F_{a2}^{(1)}$			
		0	45	90	135	180	225	270	315	0	45	90	135	180	225	270	315	→	←	↕	
900 000	3,55	125	125	125	125	125	125	125	125	125	125	125	118	118	125	125	125	35,5	71	71	35,5
	2,5	125	125	125	125	125	125	125	125	125	125	125	125	125	125	125	125	35,5	71	71	35,5
	1,8	125	125	125	125	125	125	125	125	125	125	125	125	125	125	125	125	35,5	71	71	35,5
1 120 000	3,55	106	106	118	125	125	125	125	118	125	125	118	106	100	118	125	125	35,5	71	71	35,5
	2,5	112	112	125	125	125	125	125	125	125	125	125	112	106	125	125	125	35,5	71	71	35,5
	1,8	118	118	125	125	125	125	125	125	125	125	125	118	112	125	125	125	35,5	71	71	35,5
1 400 000	2,5	100	106	112	125	125	112	118	118	125	125	112	100	95	112	125	125	35,5	71	71	35,5
	1,8	106	112	118	125	125	125	125	125	125	125	118	106	100	118	125	125	35,5	71	71	35,5
	1,25	112	118	118	125	125	125	125	125	125	125	118	112	112	118	125	125	35,5	71	71	35,5
1 800 000	2,5	95	95	106	125	118	100	106	112	112	118	106	90	85	106	125	125	33,5	71	71	33,5
	1,8	100	100	112	125	125	125	125	112	125	125	106	100	95	106	118	125	35,5	71	71	35,5
	1,25	106	106	112	125	125	125	125	112	125	125	112	106	100	112	118	125	35,5	71	71	35,5
2 240 000	2,5	85	85	95	112	112	100	106	95	112	112	95	85	80	90	100	112	35,5	71	71	35,5
	1,8	90	90	100	118	118	100	112	100	118	118	100	90	85	100	112	125	35,5	71	71	35,5
	1,25	95	95	100	118	118	118	112	106	125	118	100	95	90	100	112	125	35,5	71	71	35,5
2 800 000	2,5	71	80	85	112	112	90	95	85	95	95	90	71	75	85	106	112	35,5	71	71	35,5
	1,8	80	85	90	112	112	95	100	95	106	106	90	80	80	90	106	118	35,5	71	71	35,5
	1,25	90	90	95	106	112	112	106	100	118	112	95	90	85	95	106	118	35,5	71	71	35,5
3 550 000	1,8	75	80	85	106	100	85	90	90	95	95	85	75	71	85	95	106	35,5	67	71	31,5
	1,25	80	85	90	100	106	100	95	90	106	106	90	80	80	90	95	106	35,5	71	71	35,5
4 500 000	1,8	67	71	80	95	85	75	80	80	80	90	75	67	63	80	90	100	35,5	63	71	25
	1,25	75	75	80	95	100	90	90	85	95	95	80	75	71	80	90	100	35,5	63	71	35,5
5 600 000	1,25	67	67	75	85	90	80	85	75	85	90	75	67	63	75	85	95	35,5	60	71	31,5
max		125																35,5	71	71	35,5

1) An axial load of up 0,2 times the value in the table is permissible, simultaneously with the radial load and vice versa. If exceeded consult us.

Radial F_{r2} [daN] or axial loads F_{a2} [daN] on low speed shaft end 3.12

size **40**

$n_2 \cdot L_n$	M_2	$F_{r2}^{1)}$														$F_{a2}^{1)}$					
		0	45	90	135	180	225	270	315	0	45	90	135	180	225	270	315	UFC 645	UFC 645		
710 000	7,1	150	140	170	200	170	132	160	170	160	180	170	150	132	160	180	200	112	56	56	112
	5	160	160	180	200	200	180	190	180	200	200	180	160	150	170	200	200	112	56	56	112
	3,55	170	180	190	200	200	200	200	190	200	200	190	170	170	180	200	200	112	56	56	112
900 000	7,1	150	150	170	200	180	160	170	170	180	190	160	150	140	170	200	170	112	45	56	112
	5	160	160	170	200	200	190	190	180	200	200	170	160	150	170	190	200	112	56	56	112
	3,55	170	170	180	200	200	200	190	180	200	200	180	170	160	180	190	200	112	56	56	112
1 120 000	7,1	125	132	140	200	140	125	118	140	140	160	140	125	118	140	170	190	112	30	56	112
	5	132	140	150	200	160	140	140	160	160	170	150	132	125	150	180	200	112	56	56	112
	3,55	140	150	160	190	190	170	180	160	180	180	160	140	140	160	180	200	112	56	56	112
1 400 000	5	118	125	140	180	140	118	125	150	140	150	132	118	106	140	170	190	112	56	56	112
	3,55	132	132	150	180	170	150	160	150	170	160	140	132	125	150	170	180	112	56	56	112
	2,5	140	140	150	170	180	180	160	150	180	170	150	140	132	150	160	180	112	56	56	112
1 800 000	5	106	112	132	170	125	100	106	132	118	132	125	106	95	125	150	170	112	45	56	112
	3,55	118	112	132	160	160	132	140	140	150	150	132	118	112	132	150	170	112	56	56	112
	2,5	125	132	140	160	170	160	150	140	170	160	140	125	125	140	150	170	112	56	56	112
2 240 000	5	95	106	118	140	132	106	112	118	118	132	112	95	90	112	132	140	112	28,5	56	112
	3,55	106	112	125	150	140	118	125	125	132	140	118	106	100	125	140	160	112	56	56	112
	2,5	118	118	125	150	150	140	140	132	150	150	125	118	112	125	140	160	112	56	56	112
2 800 000	5	95	95	106	132	112	80	85	106	100	112	106	90	80	100	125	132	112	20	56	106
	3,55	100	100	112	140	125	100	106	118	118	125	112	95	90	112	132	150	112	50	56	112
	2,5	106	106	118	140	140	125	132	118	140	140	118	106	100	118	132	150	112	56	56	112
3 500 000	3,55	90	95	106	132	106	90	95	106	106	112	100	85	80	100	125	140	112	40	56	100
	2,5	95	100	106	132	132	112	118	112	125	125	106	95	90	106	125	132	112	56	56	100
4 500 000	3,55	80	85	95	125	95	80	80	100	95	100	90	80	71	95	112	132	112	30	56	90
	2,5	90	90	100	118	118	100	106	100	112	112	95	90	85	100	112	125	112	50	56	95
5 600 000	2,5	80	85	90	112	106	90	95	95	100	100	90	80	75	90	106	118	112	40	56	80
max		200														112	56	56	112		

size **41**

710 000	7,1	212	212	236	250	190	150	180	224	180	200	224	200	200	224	250	224	140	67	71	140
	5	224	224	236	250	250	236	250	236	250	250	236	212	212	224	250	250	140	71	71	140
	3,55	224	224	236	250	250	250	250	236	250	250	236	224	224	236	250	250	140	71	71	140
900 000	7,1	190	190	212	250	200	180	190	212	200	212	212	180	180	200	236	190	140	67	71	140
	5	200	200	224	250	250	212	236	212	224	250	212	200	190	212	236	250	140	71	71	140
	3,55	212	212	224	236	250	250	236	224	250	250	224	212	200	212	236	250	140	71	71	140
1 120 000	7,1	170	170	190	224	160	140	132	190	160	180	190	160	160	180	224	212	140	47,5	71	140
	5	180	190	200	224	212	170	200	200	190	212	200	180	180	190	224	236	140	71	71	140
	3,55	190	190	200	224	236	236	224	200	236	224	200	190	190	200	224	236	140	71	71	140
1 400 000	5	170	170	190	212	180	140	170	180	160	190	180	160	160	180	212	212	140	71	71	140
	3,55	180	180	190	212	224	212	200	190	224	212	190	170	170	180	200	224	140	71	71	140
	2,5	180	180	190	200	212	212	200	190	212	212	190	180	180	190	200	212	140	71	71	140
1 800 000	5	160	160	170	200	150	112	140	170	140	160	170	150	150	160	190	190	140	67	71	140
	3,55	160	160	180	190	200	180	190	170	200	200	170	160	160	170	190	212	140	71	71	140
	2,5	170	170	180	190	200	200	190	180	200	190	180	170	170	170	190	200	140	71	71	140
2 240 000	5	140	140	160	180	150	118	125	150	132	150	150	132	132	150	180	160	140	47,5	71	140
	3,55	150	150	160	180	190	160	180	160	170	180	160	150	140	160	180	190	140	71	71	140
	2,5	160	160	160	180	180	180	170	160	190	180	160	150	150	160	170	190	140	71	71	140
2 800 000	5	132	132	150	170	125	90	106	140	112	125	140	118	125	132	160	150	140	67	71	125
	3,55	140	140	150	170	160	132	150	150	150	170	150	132	132	140	160	180	140	71	71	132
	2,5	140	140	150	160	170	170	160	150	180	170	150	140	140	150	160	180	140	71	71	140
3 550 000	3,55	125	125	140	160	140	112	125	132	125	140	140	118	118	132	150	160	140	56	71	118
	2,5	132	132	140	150	160	160	150	140	170	160	140	132	125	140	150	160	140	71	71	132
4 500 000	3,55	112	118	125	150	112	90	106	125	106	118	125	112	106	118	140	150	140	45	71	106
	2,5	118	125	132	140	150	140	140	125	150	150	132	118	118	125	140	150	140	71	71	118
5 600 000	2,5	112	118	125	132	140	132	132	118	132	140	125	112	112	112	132	140	140	63	71	106
max		250														140	71	71	140		

1) An axial load of up to 0,2 times the value in the table is permissible, simultaneously with the radial load and vice versa. If exceeded consult us.

Radial F_{r2} [daN] or axial loads F_{a2} [daN] on low speed shaft end 3.12

size **50**

$n_2 \cdot L_1$ min ⁻¹ · h	M_2 daN m	$F_{r2}^{(1)}$														$F_{a2}^{(1)}$					
		0	45	90	135	180	225	270	315	0	45	90	135	180	225	270	315	→ ↓ ← →		→ ↑ ← →	
710 000	12,5	300	280	300	335	280	280	355	355	224	335	355	335	300	300	335	224	100	200	200	100
	9	315	300	335	355	315	315	355	355	315	355	335	355	315	315	335	300	100	200	200	100
900 000	12,5	280	250	265	315	236	236	355	335	180	280	355	300	265	280	280	180	100	200	200	100
	9	300	280	300	315	315	335	355	335	280	355	335	315	280	300	315	280	100	200	200	100
	6,3	300	300	300	335	355	355	355	335	355	355	335	315	300	300	315	355	100	200	200	100
1 120 000	12,5	250	224	236	265	190	200	300	300	140	224	315	265	250	250	224	140	100	200	200	75
	9	265	250	265	300	280	280	355	315	250	335	315	280	265	265	300	250	100	200	200	100
	6,3	280	265	280	300	315	315	335	315	315	335	315	300	280	280	300	315	100	200	200	100
1 400 000	9	250	224	236	280	250	250	335	280	212	300	300	265	236	250	265	212	100	200	200	100
	6,3	265	250	250	280	315	315	315	280	280	315	300	265	250	265	280	280	100	200	200	100
	4,5	265	250	265	280	300	315	315	280	315	300	300	280	265	265	280	300	100	200	200	100
1 800 000	9	224	200	212	250	212	212	300	265	170	250	280	236	224	224	250	180	100	200	200	95
	6,3	236	224	236	265	280	280	300	265	250	300	280	250	236	236	250	250	100	200	200	100
	4,5	250	236	236	265	280	300	280	265	280	280	265	250	236	250	265	280	100	200	200	100
2 240 000	9	200	180	190	236	180	180	265	236	140	212	250	224	200	200	212	140	100	200	200	67
	6,3	212	200	212	236	236	250	280	250	212	280	250	224	212	212	236	212	100	200	200	100
	4,5	224	212	224	236	265	280	265	250	265	265	250	236	224	224	236	250	100	200	200	100
2 800 000	9	180	170	180	200	150	150	236	224	112	170	236	200	180	190	180	112	100	180	200	50
	6,3	200	180	190	224	212	224	265	224	190	250	236	212	200	200	212	190	100	180	200	100
	4,5	212	200	200	224	250	265	250	224	236	250	236	212	200	212	224	236	100	200	200	100
3 550 000	6,3	180	170	180	200	190	190	236	212	160	224	212	190	180	180	200	160	100	170	200	80
	4,5	190	180	190	200	224	236	236	212	212	236	212	200	190	190	200	212	100	180	200	100
4 500 000	6,3	160	150	160	190	160	170	224	190	132	190	200	180	160	170	180	132	100	150	200	63
	4,5	170	160	170	190	200	212	212	200	190	212	200	180	170	170	190	190	100	160	200	95
5 600 000	6,3	150	140	140	170	140	140	200	180	112	160	190	160	150	150	160	112	100	140	200	50
	4,5	160	150	150	170	180	190	200	180	160	200	190	170	160	160	170	170	100	150	200	80
max		355														100	200	200	100		

size **51**

450 000	18	375	355	375	425	425	425	425	425	425	425	425	425	375	375	425	425	118	236	236	118
	12,5	375	355	355	425	425	425	425	425	425	425	425	400	375	375	425	425	118	236	236	118
560 000	18	315	280	300	375	355	375	425	400	280	425	425	355	315	315	375	280	118	236	236	118
	12,5	335	315	335	375	425	425	425	400	425	425	425	375	335	335	375	425	118	236	236	118
	9	355	335	355	400	425	425	425	400	425	425	425	375	355	355	375	425	118	236	236	118
710 000	18	280	250	265	335	300	315	425	375	224	355	400	315	280	280	335	224	118	236	236	118
	12,5	315	280	300	355	425	425	425	375	400	425	400	335	315	315	355	400	118	236	236	118
	9	335	315	315	355	400	425	425	375	425	425	375	355	335	335	355	400	118	236	236	118
900 000	18	250	224	236	315	236	250	400	335	160	265	355	280	250	265	280	160	118	236	236	80
	12,5	280	265	280	335	400	400	400	335	335	400	355	315	280	280	315	335	118	236	236	118
	9	300	280	300	335	375	400	400	355	400	375	355	315	300	300	335	375	118	236	236	118
1 120 000	18	224	190	212	280	190	200	335	300	100	190	335	265	224	236	190	100	118	236	236	45
	12,5	265	236	250	300	335	355	375	315	280	375	335	280	250	265	300	280	118	236	236	118
	9	280	250	265	300	355	375	375	315	375	355	335	300	280	280	300	335	118	236	236	118
1 400 000	12,5	236	212	224	280	280	300	355	300	236	355	315	265	236	236	265	236	118	236	236	118
	9	250	236	250	280	335	355	335	300	335	335	300	265	250	250	315	315	118	236	236	118
	6,3	265	250	265	280	315	335	335	300	335	335	300	280	265	265	280	315	118	236	236	118
1 800 000	12,5	212	190	200	250	250	250	335	265	190	300	280	236	212	212	250	190	118	236	236	90
	9	236	212	224	265	315	335	315	280	300	315	280	250	224	236	265	300	118	236	236	118
	6,3	250	236	236	265	300	315	315	280	315	300	280	265	250	250	265	300	118	236	236	118
2 240 000	12,5	190	170	180	224	200	212	315	250	140	224	265	212	190	190	224	140	118	236	236	60
	9	212	190	200	236	280	300	300	250	250	300	265	224	212	212	236	250	118	236	236	118
	6,3	224	212	212	250	280	300	280	250	280	280	265	236	224	224	236	265	118	236	236	118
2 800 000	12,5	170	150	160	212	160	170	265	224	100	180	250	200	170	180	180	100	118	212	236	40
	9	190	170	180	224	250	265	280	236	212	280	250	212	190	190	212	212	118	236	236	100
	6,3	200	190	200	224	265	280	265	236	265	265	250	212	200	200	224	250	118	236	236	118
3 550 000	9	170	160	170	200	224	224	265	212	180	265	224	190	170	180	200	180	118	212	236	80
	6,3	190	170	180	212	250	265	250	224	250	250	224	200	190	190	212	236	118	224	236	118
4 500 000	9	160	140	150	190	180	190	250	200	140	224	212	170	160	160	180	140	118	190	236	56
	6,3	170	160	170	190	224	250	236	200	224	236	212	180	170	170	190	212	118	200	236	106
5 600 000	9	140	125	132	170	150	160	236	180	112	180	190	160	140	140	170	112	118	170	236	40
	6,3	160	140	150	180	212	236	224	190	200	212	190	170	150	160	170	200	118	180	236	85
max		425 (355 per «piedi corti» - for «short feet»)														118	236	236	118		

1) An axial load of up 0,2 times the value in the table is permissible, simultaneously with the radial load and vice versa. If exceeded consult us.

Radial F_{r2} [daN] or axial loads F_{a2} [daN] on low speed shaft end 3.12

size **63**

$n_2 \cdot L_n$	M_2	$F_{r2}^{(1)}$																$F_{a2}^{(1)}$			
min ⁻¹ · h	daN · m	0	45	90	135	180	225	270	315	0	45	90	135	180	225	270	315	←	→	←	→
450 000	25	450	500	530	530	355	375	530	475	450	530	450	425	475	530	530	475	300	150	150	300
560 000	25 18	425	475	530	450	280	300	475	425	375	475	400	375	425	530	530	400	300	150	150	300
710 000	25 18	375	425	500	355	212	224	375	375	315	450	355	335	375	475	500	315	300	150	150	300
900 000	25 18 12,5	355	400	475	250	150	150	280	355	250	375	335	300	355	450	400	250	300	118	150	300
1 120 000	25 18 12,5	315	355	425	160	106	112	180	315	180	300	300	280	315	400	335	190	300	75	150	300
1 400 000	18 12,5 9	335	375	425	400	280	280	375	335	335	375	335	315	335	425	500	355	300	150	150	300
1 800 000	18 12,5 9	315	335	400	335	224	224	355	315	300	355	300	280	315	375	425	300	300	140	150	300
2 240 000	18 12,5 9	335	355	400	425	375	375	355	335	425	375	315	315	335	400	450	425	300	150	150	300
2 800 000	18 12,5 9	355	375	425	450	425	425	400	355	400	375	335	335	375	425	475	475	300	150	150	300
3 550 000	12,5 9	280	315	375	265	170	180	300	280	236	335	265	250	280	355	375	250	300	106	150	300
4 500 000	12,5 9	300	335	375	400	315	315	335	315	375	335	300	280	315	355	400	375	300	150	150	300
5 600 000	12,5 9	315	335	375	400	400	375	335	315	375	335	315	300	315	355	400	400	300	150	150	300
max		530																300	150	150	300

size **64**

$n_2 \cdot L_n$	M_2	$F_{r2}^{(1)}$																$F_{a2}^{(1)}$			
min ⁻¹ · h	daN · m	0	45	90	135	180	225	270	315	0	45	90	135	180	225	270	315	←	→	←	→
355 000	35,5	600	670	670	670	500	530	670	600	630	670	560	530	600	670	670	670	375	190	190	375
450 000	35,5 25	530	600	670	600	400	400	600	530	530	600	500	475	530	670	670	530	375	190	190	375
560 000	35,5 25 18	560	630	670	670	670	670	630	560	670	630	560	530	560	670	670	670	375	190	190	375
710 000	35,5 25 18	475	530	670	475	300	300	530	475	425	560	450	425	475	630	670	450	375	190	190	375
900 000	35,5 25 18	530	560	630	670	560	560	530	530	670	600	500	475	530	630	670	670	375	190	190	375
1 120 000	35,5 25 18	560	600	630	670	670	630	600	560	670	600	530	530	560	630	670	670	375	190	190	375
1 400 000	35,5 25 18	425	500	600	355	200	212	400	450	335	500	400	375	450	560	560	355	375	170	190	375
1 800 000	25 18 12,5	475	530	600	670	475	500	530	475	560	530	450	450	475	600	670	600	375	190	190	375
2 240 000	35,5 25 18	500	530	600	630	630	600	560	500	630	560	500	475	500	600	670	670	375	190	190	375
2 800 000	35,5 25 18	400	450	560	224	118	118	250	400	250	400	355	335	400	530	450	265	375	106	190	375
3 550 000	35,5 25 18	425	475	560	560	400	400	500	425	500	500	425	400	450	530	630	500	375	190	190	375
4 500 000	35,5 25 18	450	500	560	600	560	560	500	475	600	500	450	425	475	530	600	630	375	190	190	375
5 600 000	35,5 25 18	355	400	530	190	100	106	125	355	180	300	315	300	355	475	335	180	375	53	190	375
1 400 000	25 18 12,5	400	450	530	475	315	315	450	400	400	450	375	355	400	500	600	425	375	190	190	375
1 800 000	25 18 12,5	425	450	500	560	500	500	450	425	530	475	400	400	425	500	560	560	375	190	190	375
2 240 000	25 18 12,5	355	400	475	400	250	250	400	355	335	425	335	315	355	450	530	355	375	160	190	375
2 800 000	25 18 12,5	500	425	475	500	500	475	425	400	500	425	375	355	400	475	530	500	375	190	190	375
3 550 000	25 18 12,5	375	425	475	530	425	450	425	400	500	450	400	400	425	475	500	530	375	190	190	375
4 500 000	25 18 12,5	335	375	450	300	180	190	335	335	280	375	300	280	335	425	450	280	375	118	190	375
5 600 000	25 18 12,5	355	400	450	500	375	375	400	355	425	400	335	335	355	425	500	450	375	190	190	375
2 240 000	25 18 12,5	450	400	450	475	475	450	400	375	450	400	375	355	375	425	475	500	375	190	190	375
2 800 000	25 18 12,5	300	335	425	200	112	118	224	300	212	335	265	250	300	400	355	224	375	71	190	375
3 550 000	25 18 12,5	375	355	400	425	300	300	355	315	375	355	300	300	315	400	475	375	375	170	190	375
4 500 000	25 18 12,5	425	375	400	425	450	400	375	335	425	375	335	315	355	400	450	450	375	190	190	375
5 600 000	25 18 12,5	265	300	375	170	100	106	118	265	160	250	236	224	265	355	280	160	375	40	190	335
1 800 000	18 12,5	300	335	375	355	250	250	335	300	315	335	280	265	300	375	450	315	375	140	190	355
2 800 000	18 12,5	315	335	375	400	400	375	335	315	400	355	300	300	335	375	425	425	375	190	190	375
3 550 000	18 12,5	265	300	355	300	190	200	300	265	265	300	250	236	265	335	400	265	375	106	190	315
4 500 000	18 12,5	280	315	355	375	335	335	315	280	375	315	280	265	300	335	400	400	375	180	190	335
5 600 000	18 12,5	236	280	335	224	132	140	224	236	212	280	224	212	236	315	335	224	375	75	190	300
1 800 000	18 12,5	265	280	335	355	280	300	280	265	335	300	250	236	265	315	355	335	375	150	190	300
5 600 000	18 12,5	212	250	300	140	112	118	150	212	170	250	200	190	212	280	280	170	375	45	180	265
1 800 000	18 12,5	236	265	300	335	236	250	265	236	280	265	224	224	236	300	335	300	375	118	190	265
max		670 (530 per «piedi corti» - for «short feet»)																375	190	190	375

1) An axial load of up 0,2 times the value in the table is permissible, simultaneously with the radial load and vice versa. If exceeded consult us.

Radial F_{r2} [daN] or axial loads F_{a2} [daN] on low speed shaft end **3.12**

size **80**

$n_2 \cdot L_1$ min ⁻¹ · h	M_2 daN m	$F_{r2}^{(1)}$																$F_{a2}^{(1)}$			
		0	45	90	135	180	225	270	315	0	45	90	135	180	225	270	315	← ↓ → ↑		← ↑ → ↓	
355 000	50	800	710	750	800	710	750	800	800	600	800	800	800	750	750	800	600	224	450	450	224
	35,5	800	710	750	800	800	800	800	800	670	800	800	600	800	800	800	670	224	450	450	224
450 000	50	710	630	670	800	600	630	800	800	475	710	800	750	710	710	750	475	224	450	450	224
	35,5	750	710	710	800	800	800	800	800	750	800	800	800	750	750	800	750	224	450	450	224
560 000	50	630	560	600	710	500	500	750	800	355	560	800	710	630	630	600	375	224	450	450	224
	35,5	670	630	670	750	710	750	800	800	630	800	800	750	670	670	750	630	224	450	450	224
710 000	50	600	530	530	600	400	425	670	750	265	450	750	630	560	600	475	280	224	450	450	170
	35,5	630	560	600	670	630	630	800	750	530	750	750	670	630	630	670	560	224	450	450	224
900 000	50	530	475	500	475	315	335	530	670	180	315	710	600	530	530	335	180	224	450	450	100
	35,5	560	530	530	630	560	560	750	670	450	630	710	630	560	560	630	450	224	450	450	224
1 120 000	50	475	400	425	375	236	250	425	630	100	190	670	530	475	475	212	106	224	450	450	40
	35,5	530	475	500	560	450	475	670	630	375	530	670	560	530	530	560	375	224	450	450	224
1 400 000	50	560	530	530	600	630	630	710	630	560	710	630	600	560	560	600	560	224	450	450	224
	35,5	475	425	450	530	400	400	600	600	300	450	600	530	475	475	300	300	224	450	450	170
1 800 000	50	500	475	500	560	560	560	670	600	500	630	600	530	500	500	560	500	224	450	450	224
	35,5	530	500	500	560	630	670	630	600	600	630	600	560	530	530	560	600	224	450	450	224
2 240 000	50	425	400	400	475	315	335	500	530	224	355	560	475	425	425	375	224	224	450	450	118
	35,5	475	425	450	500	475	500	630	530	425	560	560	500	475	475	500	425	224	450	450	224
2 800 000	50	500	450	475	530	560	600	600	530	560	600	560	500	475	475	500	560	224	450	450	224
	35,5	400	335	355	375	250	265	425	500	150	265	530	450	375	400	280	160	224	400	450	67
3 550 000	50	425	400	400	475	315	335	500	530	355	500	530	450	425	425	450	355	224	450	450	200
	35,5	450	425	425	475	530	530	560	500	475	530	500	475	450	450	475	475	224	450	450	224
4 500 000	50	355	315	335	300	190	200	335	450	75	140	500	400	355	355	160	75	224	375	450	28
	35,5	280	355	375	425	355	375	500	475	300	425	475	425	375	375	425	300	224	400	450	150
5 560 000	50	400	375	400	450	475	475	530	475	425	500	475	425	400	400	425	425	224	425	450	224
	35,5	355	315	335	400	300	315	450	425	236	355	450	400	355	355	375	236	224	355	450	118
4 500 000	50	315	280	300	355	250	265	400	400	180	280	425	355	315	315	300	190	224	315	400	80
	35,5	335	315	335	375	355	375	450	400	315	425	400	375	335	335	375	315	224	335	450	160
5 560 000	50	300	265	265	300	200	212	335	375	140	224	375	315	280	280	250	140	224	300	450	50
	35,5	315	280	300	335	315	315	425	375	265	375	375	335	315	315	335	265	224	300	450	132
max		800																224	450	450	224

size **81**

$n_2 \cdot L_1$ min ⁻¹ · h	M_2 daN m	$F_{r2}^{(1)}$																$F_{a2}^{(1)}$			
		0	45	90	135	180	225	270	315	0	45	90	135	180	225	270	315	← ↓ → ↑		← ↑ → ↓	
710 000	71	1000	1000	1000	1000	1000	1000	1000	1000	950	1000	1000	1000	1000	1000	1000	950	—	560	560	—
	50	1000	900	950	1000	1000	1000	1000	1000	800	1000	1000	1000	1000	1000	1000	800	—	560	560	—
900 000	71	1000	1000	1000	1000	1000	1000	1000	1000	1000	1000	1000	1000	1000	1000	1000	1000	—	560	560	—
	50	1000	1000	1000	1000	1000	1000	1000	1000	1000	1000	1000	1000	1000	1000	1000	1000	—	560	560	—
1 120 000	71	900	850	850	1000	950	950	1000	1000	600	900	1000	1000	900	900	1000	630	—	560	560	—
	50	1000	900	950	1000	1000	1000	1000	1000	1000	1000	1000	1000	1000	1000	1000	1000	—	560	560	—
1 400 000	71	1000	1000	1000	1000	1000	1000	1000	1000	1000	1000	1000	1000	1000	1000	1000	1000	—	560	560	—
	50	1000	1000	1000	1000	1000	1000	1000	1000	1000	1000	1000	1000	1000	1000	1000	1000	—	560	560	—
1 800 000	71	900	850	900	1000	1000	1000	1000	1000	1000	1000	1000	1000	900	900	1000	1000	—	560	560	—
	50	950	900	950	1000	1000	1000	1000	1000	1000	1000	1000	1000	950	950	1000	1000	—	560	560	—
2 240 000	71	1000	950	950	1000	1000	1000	1000	1000	1000	1000	1000	1000	1000	1000	1000	1000	—	560	560	—
	50	1000	1000	1000	1000	1000	1000	1000	1000	1000	1000	1000	1000	1000	1000	1000	1000	—	560	560	—
2 800 000	71	900	850	850	950	1000	1000	1000	1000	900	1000	1000	900	850	850	900	900	—	560	560	—
	50	950	900	950	1000	1000	1000	1000	1000	1000	1000	1000	950	900	900	950	1000	—	560	560	—
3 550 000	71	1000	950	950	1000	1000	1000	1000	1000	1000	1000	1000	1000	1000	1000	1000	1000	—	560	560	—
	50	1000	1000	1000	1000	1000	1000	1000	1000	1000	1000	1000	1000	1000	1000	1000	1000	—	560	560	—
4 500 000	71	900	850	850	950	1000	1000	1000	1000	900	1000	1000	900	850	850	900	900	—	560	560	—
	50	950	900	950	1000	1000	1000	1000	1000	1000	1000	1000	950	900	900	950	1000	—	560	560	—
5 560 000	71	1000	950	950	1000	1000	1000	1000	1000	1000	1000	1000	1000	1000	1000	1000	1000	—	560	560	—
	50	1000	1000	1000	1000	1000	1000	1000	1000	1000	1000	1000	1000	1000	1000	1000	1000	—	560	560	—
710 000	71	800	710	750	850	900	900	1000	950	670	950	950	850	750	750	850	670	—	560	560	—
	50	800	750	800	900	1000	1000	1000	950	1000	1000	950	850	800	800	850	950	—	560	560	—
900 000	71	850	800	850	900	1000	1000	1000	950	1000	1000	950	900	850	850	900	950	—	560	560	—
	50	850	800	850	900	1000	1000	1000	950	1000	1000	950	900	850	850	900	950	—	560	560	—
1 120 000	71	710	630	670	800	800	800	1000	850	560	800	900	800	710	710	800	560	—	560	560	—
	50	750	710	750	800	950	1000	1000	850	900	950	900	800	750	750	800	900	—	560	560	—
1 400 000	71	800	750	750	850	900	950	950	850	950	950	900	800	800	800	850	900	—	560	560	—
	50	800	750	750	850	900	950	950	850	950	950	900	800	800	800	850	900	—	560	560	—
1 800 000	71	710	670	670	750	900	900	900	800	800	900	850	750	710	710	750	850	—	560	560	—
	50	750	710	710	800	850	900	900	800	900	900	850	750	710	750	750	850	—	560	560	—
2 240 000																					

Radial F_{r2} [daN] or axial loads F_{a2} [daN] on low speed shaft end 3.12

$n_2 \cdot L_1$ min ⁻¹ · h	M_2 daN m	$F_{r2}^{(1)}$														$F_{a2}^{(1)}$					
		0	45	90	135	180	225	270	315	0	45	90	135	180	225	270	315	size		100	
280 000	100	1250	1250	1250	1250	1000	1000	1250	1250	1250	1250	1250	1250	1250	1250	1250	1250	710	355	355	710
355 000	100	1180	1250	1250	1180	800	850	1250	1180	1060	1250	1120	1120	1250	1250	1250	1060	710	355	355	710
450 000	100 71	1120	1250	1250	950	630	630	1060	1060	850	1250	1000	1000	1120	1250	1250	900	710	355	355	710
560 000	100 71 50	1060	1180	1250	1250	900	950	1120	1060	1120	1180	1000	1000	1060	1250	1250	1120	710	355	355	710
710 000	100 71 50	1000	1120	1250	1250	1250	1250	1180	1120	710	1060	950	900	1000	1250	1120	710	710	355	355	710
900 000	100 71 50	900	1000	1250	530	300	315	600	900	560	850	850	800	900	1180	950	560	710	265	355	710
1 120 000	100 71 50	950	1060	1180	1120	800	800	1060	950	950	1060	950	900	1000	1180	1250	950	710	355	355	710
1 400 000	100 71 50	1000	1120	1250	1120	1120	1120	1060	1000	1250	1120	1000	950	1060	1180	1250	1250	710	355	355	710
1 800 000	100 71 50 35,5	800	950	1120	280	150	150	335	800	400	670	750	710	800	1060	710	425	710	160	355	710
2 240 000	100 71 50	900	1000	1120	900	630	630	950	900	800	1000	850	800	900	1060	1180	800	710	355	355	710
2 800 000	100 71 50	950	1000	1120	1180	950	1000	1000	950	1060	1000	900	900	950	1060	1180	1120	710	355	355	710
3 550 000	100 71 50	750	850	1000	375	200	212	425	750	425	710	670	630	750	950	750	450	710	170	355	710
4 500 000	71 50 35,5	800	900	1060	750	500	500	800	800	670	900	750	750	800	1000	1000	670	710	335	355	710
5 600 000	71 50 35,5	850	900	1000	1120	850	850	900	850	950	950	850	800	850	1000	1120	950	710	355	355	710
1 400 000	71 50 35,5	750	800	950	600	375	400	670	750	560	800	710	670	750	900	850	560	710	250	355	710
1 800 000	71 50 35,5	800	850	950	950	710	750	850	800	850	850	750	750	800	950	1060	850	710	355	355	710
2 240 000	71 50 35,5	800	850	950	1000	950	950	850	800	950	900	800	800	850	900	1000	1000	710	355	355	710
2 800 000	71 50 35,5	670	750	900	450	265	280	500	670	450	670	630	600	670	850	710	450	710	180	355	710
3 550 000	71 50 35,5	710	800	900	850	600	630	800	710	750	800	710	670	750	850	1000	750	710	355	355	710
4 500 000	71 50 35,5	750	800	900	950	850	850	800	750	900	800	750	710	750	850	950	950	710	355	355	710
5 600 000	71 50 35,5	600	670	850	236	125	125	265	600	335	530	560	530	600	800	560	335	710	100	355	630
2 800 000	71 50 35,5	670	710	800	710	500	500	710	670	630	710	630	600	670	800	900	630	710	280	355	670
3 550 000	71 50 35,5	710	750	800	850	710	750	750	670	800	750	670	670	710	800	850	850	710	355	355	710
4 500 000	71 50 35,5	560	630	750	315	170	170	355	560	355	530	500	475	560	710	600	355	710	112	355	630
5 600 000	50 35,5	600	670	750	600	400	425	630	600	530	670	560	560	600	750	750	530	710	224	355	600
1 120 000	50 35,5	630	670	750	800	630	630	670	630	710	670	630	600	630	750	800	750	710	355	355	630
1 400 000	50 35,5	560	600	710	500	315	315	530	560	450	600	530	500	560	670	670	450	710	170	355	560
1 800 000	50 35,5	600	630	710	750	560	560	630	600	630	630	560	560	600	670	750	630	710	300	355	560
2 240 000	50 35,5	500	560	670	375	224	236	425	500	355	530	475	450	500	630	560	355	710	118	355	530
2 800 000	50 35,5	530	560	630	630	475	475	560	530	560	600	500	500	530	630	710	560	710	250	355	530
3 550 000	50 35,5	450	500	600	190	106	106	224	450	280	425	425	400	450	560	450	280	710	71	355	450
4 500 000	50 35,5	475	530	600	560	375	400	530	475	475	530	475	450	500	600	670	475	710	200	355	475
max		1 250 (1 120 per «piedi corti» - for «short feet»)														710	355	355	710		

size	101																	size		101	
		0	45	90	135	180	225	270	315	0	45	90	135	180	225	270	315				
560 000	140	1600	1600	1600	1600	1250	1250	1600	1600	1600	1600	1600	1600	1600	1600	1600	1600	900	—	—	900
710 000	140	1600	1600	1600	1500	950	1000	1600	1600	1600	1600	1600	1500	1600	1600	1600	1600	900	—	—	900
900 000	140 100	1500	1600	1600	1120	710	710	1250	1500	1320	1600	1400	1400	1500	1600	1600	1320	900	—	—	900
1 120 000	140 100 71	1600	1600	1600	1600	1600	1600	1600	1600	1600	1600	1600	1500	1600	1600	1600	1600	900	—	—	900
1 400 000	140 100 71	1400	1600	1600	750	450	450	900	1400	1120	1600	1320	1250	1400	1600	1600	1120	900	—	—	900
1 800 000	100 71 50	1500	1600	1600	1600	1400	1500	1600	1500	1600	1600	1400	1400	1500	1600	1600	1600	900	—	—	900
2 240 000	100 71 50	1600	1600	1600	1600	1600	1600	1600	1600	1600	1600	1500	1500	1600	1600	1600	1600	900	—	—	900
2 800 000	100 71 50	1400	1500	1600	1500	1060	1120	1500	1400	1500	1500	1320	1250	1400	1600	1600	1500	900	—	—	900
3 550 000	100 71 50	1400	1500	1600	1600	1600	1600	1500	1400	1600	1600	1400	1400	1500	1600	1600	1600	900	—	—	900
4 500 000	100 71 50	1500	1600	1600	1600	1600	1600	1600	1500	1600	1600	1500	1400	1500	1600	1600	1600	900	—	—	900
5 600 000	100 71 50	1250	1400	1600	1250	850	900	1400	1250	1320	1400	1250	1180	1250	1500	1600	1320	900	—	—	900
2 240 000	100 71 50	1320	1400	1600	1600	1500	1600	1400	1320	1600	1500	1320	1250	1320	1500	1600	1600	900	—	—	900
2 800 000	100 71 50	1400	1500	1600	1600	1600	1600	1500	1400	1600	1500	1400	1320	1400	1500	1600	1600	900	—	—	900
3 550 000	100 71 50	1250	1400	1600	1250	850	900	1400	1250	1320	1400	1250	1180	1250	1500	1600	1320	900	—	—	900
4 500 000	100 71 50	1600	1600	1600	1600	1600	1600	1600	1600	1600	1600	1600	1500	1600	1600	1600	1600	900	—	—	900
5 600 000	100 71 50	1600	1600	1600	1600	1600	1600	1600	1600	1600	1600	1600	1500	1600	1600	1600	1600	900	—	—	900
2 240 000	100 71 50	1180	1250	1500	1000	670	670	1120	1180	1120	1320	1120	1060	1180	1400	1600	1120	900	—	—	900
2 800 000	100 71 50	1250	1320	1500	1600	1320	1400	1320	1250	1500	1320	1180	1180	1250	1400	1600	1500	900	—	—	900
3 550 000	100 71 50	1250	1320	1500	1500	1500	1500	1320	1250	1500	1400	1250	1250	1320	1400	1500	1600	900	—	—	900
4 500 000	100 71 50	1060	1180	1400	750	475	500	850	1060	950	1180	1000	950	1060	1320	1400	950	900	—	—	900
5 600 000	100 71 50	1120	1250	1400	1500	1180	1180	1250	1120	1320	1250	1120	1060	1180	1320	1500	1400	900	—	—	900
3 550 000	71 50	1060	1120	1250	1250	1000	1060	1120	1060	1180	1180	1000	1000	1060	1250	1400	1250	900	—	—	900
4 500 000	71 50	1120	1180	125	1320	1320	1250	1180	1120	1320	1180	1060	1060	1120	1250	1400	1400	900	—	—	900
5 600 000	71 50	950	1060	1180	1060	750	800	1060	950	1060	1060	950	900	1000	1180	1320	1060	900	—	—	900
max		1 600 (1 120 per «piedi corti» - for «short feet»)																			

Radial F_{r2} [daN] or axial loads F_{a2} [daN] on low speed shaft end 3.12

size **125**

$n_2 \cdot L_1$ min ⁻¹ · h	M_2 daN m	$F_{r2}^{(1)}$												$F_{a2}^{(1)}$							
		0	45	90	135	180	225	270	315	0	45	90	135	180	225	270	315	→ ↓ ← ↑	→ ↑ ← ↓		
560 000	200	2000	2000	2000	2000	2000	2000	2000	2000	1900	2000	2000	2000	2000	1900	1700	1700	560	1120	1120	560
710 000	200	2000	2000	2000	2000	2000	2000	2000	2000	1700	1900	2000	2000	2000	1700	1500	1500	560	1120	1120	560
900 000	200 140	2000 2000	1800 1900	1800 1900	2000 2000	2000 2000	2000 2000	2000 2000	2000 2000	1500 1800	1700 2000	1800 2000	2000 2000	1900 2000	1400 1900	1250 1700	1320 1700	560 560	1120 1120	1120 1120	560 560
1 120 000	200 140 100	1800 1900 2000	1600 1800 1900	1700 1800 1900	1900 2000 2000	1900 2000 2000	1900 2000 2000	2000 2000 2000	2000 2000 2000	1320 1600 1900	1500 1800 2000	1600 1900 2000	1800 2000 2000	1600 1900 2000	1180 1700 1900	1060 1500 1800	1120 1500 1800	560 560 560	1120 1120 1120	1120 1120 1120	560 560 560
1 400 000	140 100 71	1800 1800 1900	1600 1700 1800	1700 1700 1800	1800 1900 1900	2000 2000 2000	2000 2000 2000	2000 2000 2000	2000 2000 2000	1500 1700 1900	1600 1800 2000	1800 1900 1900	1900 1900 1900	1800 1800 1800	1500 1800 1800	1320 1600 1800	1400 1600 1800	560 560 560	1120 1120 1120	1120 1120 1120	560 560 560
1 800 000	140 100 71	1700 1700 1800	1500 1600 1700	1500 1600 1700	1700 1700 1800	2000 1900 1900	2000 2000 2000	2000 2000 1900	1900	1320 1600 1700	1500 1700 1800	1600 1800 1900	1800 1800 1800	1600 1700 1700	1320 1600 1700	1180 1500 1700	1250 1500 1700	560 560 560	1120 1120 1120	1120 1120 1120	560 560 560
2 240 000	140 100 71	1500 1600 1600	1400 1500 1500	1400 1500 1600	1600 1600 1600	1700 1800 1800	1800 1900 1900	1800 1800 1700	1800	1180 1400 1600	1320 1500 1700	1400 1600 1800	1600 1700 1700	1500 1600 1600	1180 1500 1500	1060 1320 1320	1060 1320 1500	560 560 560	1120 1120 1120	1120 1120 1120	560 560 560
2 800 000	140 100 71	1400 1500 1500	1250 1400 1400	1250 1400 1400	1500 1500 1500	1500 1700 1800	1600 1800 1800	1900 1700 1600	1700	1060 1250 1400	1180 1400 1500	1320 1600 1600	1500 1500 1500	1400 1320 1320	1000 1180 1180	900 1180 1180	950 1180 1400	560 560 560	1120 1120 1120	1120 1120 1120	560 560 560
3 550 000	100 71	1400 1400	1250 1320	1250 1320	1400 1400	1600 1600	1700 1700	1700 1600	1500	1180 1320	1250 1400	1400 1500	1500 1500	1320 1400	1180 1400	1060 1250	1060 1250	560 560	1120 1120	1120 1120	560 560
4 500 000	100 71	1250 1320	1180 1250	1180 1250	1320 1320	1500 1500	1600 1600	1600 1500	1400	1060 1180	1120 1250	1250 1400	1320 1400	1250 1250	1060 1180	950 1120	950 1120	560 560	1120 1120	1120 1120	560 560
5 600 000	100 71	1180 1180	1060 1120	1060 1120	1180 1250	1400 1400	1400 1500	1500 1400	1320	950 1120	1060 1250	1120 1250	1120 1250	950 1180	850 1060	850 1060	560 560	1120 1120	1120 1120	560 560	
max		2 000 (1 800 per «piedi corti» - for «short feet»)															560 1120	1 120 560			

size **126**

280 000	280	2500	2500	2500	2500	2500	2500	2500	2500	2240	2500	2500	2500	2500	2360	2000	2000	710	1400	1400	710
355 000	280	2500	2500	2500	2500	2500	2500	2500	2500	2000	2360	2500	2500	2500	2000	1700	1800	710	1400	1400	710
450 000	280 200	2500 2500	2360 2500	2360 2500	2500 2500	2360 2500	2360 2500	2500 2560	2500	1800 2240	2000 2500	2240 2500	2500 2500	2360 2500	1700 2360	1500 2120	1500 2120	710 710	1400 1400	1400 1400	710 710
560 000	280 200 140	2500 2500 2500	2360 2360 2500	2120 2360 2500	2500 2500 2500	2000 2500 2500	2120 2500 2500	2500 2500 2500	2500	1500 2000 2360	1800 2240 2500	2000 2500 2500	2240 2500 2500	2000 2120 2500	1400 2120 2240	1250 1800 2240	1320 1800 2240	710 710 710	1400 1400 1400	1400 1400 1400	710 710 710
710 000	280 200 140	2240 2360 2500	2000 2120 2240	2000 2240 2360	2240 2500 2500	1700 2500 2500	1800 2500 2500	2500 2500 2500	2500	1250 1800 2120	1600 2000 2360	1700 2240 2500	1900 2500 2500	1600 2360 2360	1120 1900 2000	1000 1600 2120	1120 1600 2120	710 710 710	1400 1400 1400	1400 1400 1400	670 710 710
900 000	280 200 140	2000 2120 2240	1800 2000 2120	1800 2000 2120	1900 2240 2360	1400 2120 2500	1500 2240 2500	2240 2500 2500	2500	900 1600 1900	1400 1800 2120	1500 2000 2360	1500 2120 2500	1250 2500 2500	850 1600 2000	750 1400 1800	900 1400 1800	710 710 710	1400 1400 1400	1400 1400 1400	475 710 710
1 120 000	280 200 140	1900 2000 2120	1600 1800 1900	1600 1800 2000	1600 2120 2360	1180 1900 2360	1180 1900 2500	1900 2360 2360	2360	630 1400 1800	1060 1600 1900	1250 1800 2120	1180 2000 2240	850 1900 2120	560 1400 1800	530 1180 1600	670 1250 1600	710 710 710	1400 1400 1400	1400 1400 1400	315 710 710
1 400 000	200 140 100	1900 1900 2000	1700 1800 1900	1700 1800 1900	1900 2000 2120	1700 2240 2360	1700 2240 2360	2360 2240 2240	2240	1250 1600 1800	1400 1700 1900	1600 1900 2120	1800 2120 2120	1700 1900 2000	1180 1700 1900	1000 1500 1800	1060 1500 1700	710 710 710	1400 1400 1400	1400 1400 1400	710 710 710
1 800 000	200 140 100	1700 1800 1900	1500 1700 1800	1500 1700 1800	1800 1900 1900	1400 2000 2120	1500 2000 2240	2120 2120 2000	2120	1060 1400 1700	1250 1600 1800	1400 1900 2000	1600 1800 2000	1400 1800 1800	1000 1500 1800	850 1320 1600	900 1320 1600	710 710 710	1400 1400 1400	1400 1400 1400	600 710 710
2 240 000	200 140 100	1600 1700 1700	1400 1500 1600	1400 1500 1600	1600 1700 1800	1180 1700 1900	1250 1800 2000	1800 1900 1900	1900	800 1250 1500	1120 1400 1600	1250 1600 1800	1320 1800 1800	1120 1700 1700	750 1320 1400	670 1180 1400	750 1180 1400	710 710 710	1400 1400 1400	1400 1400 1400	450 710 710
2 800 000	200 140 100	1500 1500 1600	1250 1400 1500	1250 1400 1500	1320 1600 1600	1000 1500 1800	1000 1600 1900	1800 2000 1800	1800	630 1120 1400	950 1320 1500	1060 1400 1700	1060 1600 1700	850 1500 1600	560 1180 1400	530 1000 1250	600 1000 1250	710 710 710	1400 1400 1400	1400 1400 1400	335 710 710
3 550 000	140 100	1400 1500	1250 1400	1320 1400	1500 1500	1400 1700	1400 1800	1900 1700	1700	1000 1250	1180 1320	1250 1500	1500 1600	1400 1500	1000 1320	900 1180	900 1180	710 710	1400 1400	1400 1400	630 710
4 500 000	140 100	1320 1400	1180 1250	1180 1250	1400 1400	1180 1500	1250 1600	1700 1700	1600	900 1120	1060 1250	1120 1320	1320 1500	1180 1400	850 1180	750 1060	800 1060	710 710	1400 1400	1400 1400	530 710
5 600 000	140 100	1250 1250	1060 1180	1120 1180	1250 1320	1000 1400	1060 1400	1500 1600	1500	750 1000	900 1120	1000 1250	1120 1400	1000 1250	710 1060	600 900	670 900	710 710	1250 1320	1400 1400	425 670
max		2 500 (1 800 per «piedi corti» - for «short feet»)															710 1400	1 400 710			

1) An axial load of up to 0,2 times the value in the table is permissible, simultaneously with the radial load and vice versa. If exceeded consult us.

Radial F_{r2} [daN] or axial loads F_{a2} [daN] on low speed shaft end 3.12

size **140**

$n_2 \cdot L_n$	M_2	$F_{r2}^{(1)}$												$F_{a2}^{(1)}$								
min ⁻¹ · h	daN · m	0	45	90	135	180	225	270	315	0	45	90	135	180	225	270	315	←	→	↑	↓	
280 000	400	3150	3150	3150	3150	3150	3150	3150	3150	2800	3150	3150	3150	3150	3150	3000	2650	2650	900	1800	1800	900
	280	3150	3150	3150	3150	3150	3150	3150	3150	3150	3150	3150	3150	3150	3150	3150	3150	900	1800	1800	900	
	200	3150	3150	3150	3150	3150	3150	3150	3150	3150	3150	3150	3150	3150	3150	3150	3150	900	1800	1800	900	
355 000	400	3150	3000	3000	3150	3150	3150	3150	3150	2650	3000	3150	3150	3150	2650	2240	2240	900	1800	1800	900	
	280	3150	3150	3150	3150	3150	3150	3150	3150	3150	3150	3150	3150	3150	3150	3000	3000	900	1800	1800	900	
	200	3150	3150	3150	3150	3150	3150	3150	3150	3150	3150	3150	3150	3150	3150	3150	3150	900	1800	1800	900	
450 000	400	3150	2800	2800	3150	3000	3000	3150	3150	2240	2650	3000	3150	3150	2240	1900	2000	900	1800	1800	900	
	280	3150	3000	3000	3150	3150	3150	3150	3150	2800	3150	3150	3150	3150	3150	2650	2650	900	1800	1800	900	
	200	3150	3150	3150	3150	3150	3150	3150	3150	3150	3150	3150	3150	3150	3150	3150	3150	900	1800	1800	900	
560 000	400	2800	2500	2500	2800	2500	2650	3150	2500	1900	2360	2650	3150	2800	1900	1600	1700	900	1800	1800	900	
	280	3000	2800	2800	3000	3150	3150	3150	3150	2500	2800	3150	3150	3000	2800	2360	2360	900	1800	1800	900	
	200	3150	3000	3000	3150	3150	3150	3150	3150	3000	3150	3150	3150	3150	3000	2800	2800	900	1800	1800	900	
710 000	400	2650	2360	2360	2500	2240	2240	3150	3150	1600	2000	2360	2650	2360	1600	1320	1400	900	1800	1800	900	
	280	2800	2500	2650	2800	3150	3150	3150	3150	2360	2650	3000	3000	2800	2500	2120	2120	900	1800	1800	900	
	200	2800	2650	2650	3000	3150	3150	3150	3150	2650	3000	3150	3000	2800	2800	2650	2650	900	1800	1800	900	
900 000	400	2500	2120	2120	2120	1800	1900	2800	3000	1180	1800	2000	2240	1800	1250	1060	1120	900	1800	1800	750	
	280	2650	2360	2360	2650	2800	2800	3150	3000	2120	2360	2650	2800	2500	2240	1900	1900	900	1800	1800	900	
	200	2650	2500	2500	2650	3000	3150	3150	3000	2500	2650	3000	2800	2650	2650	2360	2360	900	1800	1800	900	
1 120 000	400	2240	1900	1900	1700	1500	1500	2500	2800	850	1400	1700	1800	1320	900	750	850	900	1800	1800	530	
	280	2360	2120	2120	2360	2360	2500	3150	2800	1800	2120	2360	2650	2360	1900	1600	1600	900	1800	1800	900	
	200	2500	2240	2360	2500	2800	3000	3000	2800	2240	2500	2650	2650	2500	2360	2120	2120	900	1800	1800	900	
1 400 000	280	2240	2000	2000	2240	2120	2240	2800	2650	1600	1900	2120	2500	2240	1600	1400	1400	900	1800	1800	900	
	200	2360	2120	2120	2360	2650	2800	2800	2650	2000	2240	2500	2500	2240	2120	1900	1900	900	1800	1800	900	
	140	2360	2240	2240	2360	2650	2800	2800	2650	2360	2500	2650	2500	2360	2360	2240	2240	900	1800	1800	900	
1 800 000	280	2000	1800	1800	2000	1800	1900	2650	2500	1400	1700	1900	2240	2000	1400	1180	1250	900	1800	1800	900	
	200	2120	2000	2000	2120	2500	2500	2650	2500	1800	2000	2240	2360	2120	2000	1700	1700	900	1800	1800	900	
	140	2240	2120	2120	2240	2500	2650	2650	2360	2120	2240	2500	2360	2240	2120	2120	2000	900	1800	1800	900	
2 240 000	280	1900	1600	1700	1700	1600	1600	2240	2240	1120	1500	1700	1900	1600	1120	950	1000	900	1800	1800	710	
	200	2000	1800	1800	2000	2240	2240	2500	2240	1600	1800	2000	2120	2000	1700	1500	1500	900	1800	1800	900	
	140	2000	1900	1900	2000	2240	2360	2360	2240	1900	2120	2240	2120	2000	2000	1900	1800	900	1800	1800	900	
2 800 000	280	1700	1500	1500	1500	1320	1320	2120	2120	850	1250	1400	1600	1320	900	750	850	900	1800	1800	530	
	200	1800	1700	1700	1900	1900	2000	2360	2120	1500	1700	1900	2000	1800	1500	1320	1320	900	1800	1800	900	
	140	1900	1800	1800	1900	1900	2120	2240	2120	1700	1900	2120	2000	1900	1800	1700	1700	900	1800	1800	900	
3 550 000	200	1700	1500	1500	1700	1700	1800	2240	2000	1320	1500	1700	1900	1700	1320	1120	1180	900	1800	1800	900	
	140	1800	1600	1600	1800	2000	2120	2120	2000	1600	1700	1900	1900	1800	1700	1500	1500	900	1800	1800	900	
4 500 000	200	1600	1400	1400	1600	1500	1500	2000	1900	1120	1320	1500	1700	1600	1180	1000	1000	900	1800	1800	750	
	140	1600	1500	1500	1700	1900	2000	2000	1800	1400	1600	1800	1700	1600	1500	1400	1320	900	1800	1800	900	
5 600 000	200	1400	1250	1250	1400	1250	1320	1800	1700	950	1180	1320	1500	1400	950	800	850	900	1700	1800	600	
	140	1500	1400	1400	1500	1700	1800	1900	1700	1250	1400	1600	1600	1500	1400	1180	1180	900	1700	1800	900	
max		3 150 (2 000 per «piedi corti» - for «short feet»)															900	1 800	1 800	900		

1) An axial load of up to 0,2 times the value in the table is permissible, simultaneously with the radial load and vice versa. If exceeded consult us.
 2) An unfavourable direction of load can limit F_{r2} to $0,9 \cdot F_{r2max}$

Radial F_{r2} [daN] or axial loads F_{a2} [daN] on low speed shaft end 3.12

size **160**

$n_2 \cdot L_n$ min ⁻¹ · h	M_2 daN m	$F_{r2}^{(1)}$														$F_{a2}^{(1)}$					
		0	45	90	135	180	225	270	315	0	45	90	135	180	225	270	315	→	←	→	←
224 000	560	4000	4000	4000	4000	4000	3750	3550	4000	4000	4000	4000	4000	4000	4000	4000	4000	2240	1120	1120	2240
	400	4000	4000	4000	4000	4000	4000	4000	4000	4000	4000	4000	4000	4000	4000	4000	4000	2240	1120	1120	2240
	280	4000	4000	4000	4000	4000	4000	4000	4000	4000	4000	4000	4000	4000	4000	4000	4000	2240	1120	1120	2240
280 000	560	4000	4000	4000	4000	3550	3350	3150	3550	4000	4000	4000	4000	4000	4000	4000	4000	2240	1120	1120	2240
	400	4000	4000	4000	4000	4000	4000	4000	4000	4000	4000	4000	4000	4000	4000	4000	4000	2240	1120	1120	2240
	280	4000	4000	4000	4000	4000	4000	4000	4000	4000	4000	4000	4000	4000	4000	4000	4000	2240	1120	1120	2240
355 000	560	4000	4000	4000	3750	3350	2800	2800	3150	4000	4000	3750	3750	4000	4000	4000	4000	2240	1120	1120	2240
	400	4000	4000	4000	4000	4000	3750	3750	4000	4000	4000	4000	4000	4000	4000	4000	4000	2240	1120	1120	2240
	280	4000	4000	4000	4000	4000	4000	4000	4000	4000	4000	4000	4000	4000	4000	4000	4000	2240	1120	1120	2240
450 000	560	3750	4000	3550	3350	2800	2500	2360	2650	4000	4000	3350	3350	3750	4000	4000	4000	2240	1120	1120	2240
	400	4000	4000	4000	4000	3550	3350	3350	3750	4000	4000	3750	3750	4000	4000	4000	4000	2240	1120	1120	2240
	280	4000	4000	4000	4000	4000	4000	4000	4000	4000	4000	4000	4000	4000	4000	4000	4000	2240	1120	1120	2240
560 000	560	3000	3550	3150	3000	2500	2120	1900	2240	3550	3550	3150	3000	3550	4000	4000	3550	2240	1120	1120	2240
	400	3550	4000	4000	3550	3150	3000	3000	3350	4000	3750	3350	3350	3750	4000	4000	4000	2240	1120	1120	2240
	280	3750	4000	4000	4000	3750	3550	3550	3750	4000	4000	3550	3550	3750	4000	4000	4000	2240	1120	1120	2240
710 000	560	2500	3000	2800	2650	2120	1700	1600	1800	3000	3150	2800	2800	3150	4000	4000	3000	2240	1060	1120	2240
	400	3350	3750	3550	3150	2800	2650	2650	3000	4000	3550	3150	3150	3350	4000	4000	4000	2240	1120	1120	2240
	280	3550	3750	4000	3750	3350	3150	3150	3550	4000	3550	3350	3350	3550	4000	4000	4000	2240	1120	1120	2240
900 000	560	1900	2360	2360	2240	1600	1400	1180	1320	2500	2800	2500	2500	3000	3750	3750	2500	2240	750	1120	2240
	400	3150	3550	3150	2800	2500	2240	2240	2500	3750	3150	2800	2800	3150	3750	4000	3750	2240	1120	1120	2240
	280	3350	3550	3550	3350	3150	2800	3000	3150	3750	3350	3150	3000	3350	3750	4000	4000	2240	1120	1120	2240
1 120 000	560	1320	1800	2000	1900	1180	1060	850	900	2000	2240	2360	2240	2650	3550	3350	2120	2240	500	1120	2240
	400	2800	3150	2800	2650	2240	2000	1900	2240	4000	3750	3350	3350	3000	3550	4000	3350	2240	1120	1120	2240
	280	3000	3350	3350	3000	2800	2650	2650	3000	3550	3150	2800	2800	3000	3550	3750	3750	2240	1120	1220	2240
1 400 000	400	2650	2800	2500	2360	2000	1700	1600	1900	2800	2800	2360	2360	2650	3350	3750	2800	2240	1120	1120	2240
	280	2800	3000	3000	2800	2500	2360	2360	2650	3350	2800	2650	2650	2800	3350	3550	3550	2240	1120	1120	2240
	200	2800	3000	3350	3000	2800	2800	2800	2800	3350	3000	2800	2800	3000	3150	3550	3550	2240	1120	1120	2240
1 800 000	400	2120	2500	2240	2000	1800	1500	1400	1500	2500	2500	2240	2120	2500	3150	3350	2500	2240	950	1120	2240
	280	2650	2800	2800	2500	2240	2120	2120	2360	3150	2650	2360	2360	2650	3000	3350	3350	2240	1120	1120	2240
	200	2650	2800	3000	2800	2650	2500	2500	2650	3000	2800	2500	2500	2800	3000	3350	3350	2240	1120	1120	2240
2 240 000	400	1700	2000	1900	1800	1500	1180	1060	1180	2120	2240	2000	2000	2240	2800	3000	2120	2240	710	1120	2240
	280	2360	2650	2500	2240	2000	1800	1800	2120	2800	2500	2240	2240	2360	2800	3150	3000	2240	1120	1120	2240
	200	2500	2650	2800	2500	2360	2240	2240	2500	2800	2500	2360	2360	2500	2800	3000	3000	2240	1120	1120	2240
2 800 000	400	1320	1700	1700	1600	1120	950	850	900	1700	1900	1800	1800	2120	2650	2650	1800	2240	530	1120	2240
	100	2240	2500	2000	2240	1800	1600	1600	1800	2650	2360	2000	2000	2240	2650	3000	2650	2240	1120	1120	2240
	200	2360	2500	2500	2360	2120	2000	2000	2240	2650	2360	2120	2120	2360	2650	2800	2800	2240	1120	1120	2240
3 550 000	280	2000	2240	2000	1900	1600	1400	1400	1600	2360	2120	1900	1900	2120	2800	2800	2360	2240	1000	1120	2240
	200	2120	2360	2360	2120	2000	1800	1900	2120	2500	2240	2000	2000	2120	2500	2650	2800	2240	1120	1120	2240
4 500 000	280	1900	2000	1800	1600	1400	1250	1180	1320	2000	2000	1700	1700	1900	2360	2650	2120	2240	850	1120	2240
	200	2000	2120	2120	2000	1800	1700	1600	1900	2360	2000	1900	1800	2000	2360	2500	2500	2240	1120	1200	2240
5 600 000	280	1500	1700	1600	1500	1250	1060	950	1120	1800	1800	1600	1500	1800	2120	2360	1800	2240	670	1120	2000
	200	1800	2000	1900	1800	1600	1500	1500	1700	2240	1900	1700	1700	1900	2120	2360	2360	2240	1120	1120	2120
max		4 000 (2 800 per «piedi corti» - for «short feet»)														2 240 1120	1 120 2 240				

1) An axial load of up 0,2 times the value in the table is permissible, simultaneously with the radial load and vice versa. If exceeded consult us.

Radial F_{r2} [daN] or axial loads F_{a2} [daN] on low speed shaft end 3.12

size **180**

$n_2 \cdot L_h$	M_2	$F_{r2}^{1)}$														$F_{a2}^{1)}$					
min ⁻¹ · h	daN · m	0	45	90	135	180	225	270	315	0	45	90	135	180	225	270	315	↓	↑	←	→
224 000	800	5000	5000	5000	5000	4500	4000	4000	4750	5000	5000	5000	5000	5000	5000	5000	5000	2800	1400	1400	2800
	560	5000	5000	5000	5000	5000	5000	5000	5000	5000	5000	5000	5000	5000	5000	5000	5000	2800	1400	1400	2800
	400	5000	5000	5000	5000	5000	5000	5000	5000	5000	5000	5000	5000	5000	5000	5000	5000	2800	1400	1400	2800
280 000	800	5000	5000	5000	4500	4000	3550	3550	4000	5000	5000	4750	4750	5000	5000	5000	5000	2800	1400	1400	2800
	560	5000	5000	5000	5000	5000	5000	4500	4750	5000	5000	5000	5000	5000	5000	5000	5000	2800	1400	1400	2800
	400	5000	5000	5000	5000	5000	5000	5000	5000	5000	5000	5000	5000	5000	5000	5000	5000	2800	1400	1400	2800
355 000	800	4750	5000	4750	4000	3550	3000	3000	3550	4500	5000	4250	4250	5000	5000	5000	4750	2800	1400	1400	2800
	560	5000	5000	5000	5000	4500	4250	4250	4750	5000	5000	4750	4750	5000	5000	5000	5000	2800	1400	1400	2800
	400	5000	5000	5000	5000	5000	4750	5000	5000	5000	5000	5000	5000	5000	5000	5000	5000	2800	1400	1400	2800
450 000	800	4250	4750	4000	3550	3000	2650	2500	3000	4000	4500	4000	4000	4500	5000	5000	5000	2800	1400	1400	2800
	560	4750	5000	5000	4500	4000	3750	3750	4250	5000	4750	4250	4250	4750	5000	5000	5000	2800	1400	1400	2800
	400	4750	5000	5000	5000	4500	4250	4500	4750	5000	4750	4500	4500	4750	5000	5000	5000	2800	1400	1400	2800
560 000	800	3350	4000	3550	3150	2240	2120	2000	2360	3350	4000	3550	3550	4250	5000	5000	3350	2800	1400	1400	2800
	560	4250	4750	4500	4000	3550	3350	3350	3750	5000	4500	4000	4000	4250	5000	5000	5000	2800	1400	1400	2800
	400	4500	4750	5000	4500	4250	4000	4000	4250	5000	4500	4250	4250	4500	5000	5000	5000	2800	1400	1400	2800
710 000	800	2800	3350	3150	2800	1700	1800	1600	1900	2800	3350	3350	3350	3750	4750	4500	2800	2800	1180	1400	2800
	560	4000	4500	4000	3550	3150	2800	2800	3350	4250	4000	3750	3750	4000	4750	5000	4500	2800	1400	1400	2800
	400	4250	4500	4500	4250	3750	3550	3750	4000	4750	4250	4000	4000	4250	4750	5000	5000	2800	1400	1400	2800
900 000	800	2000	2650	2650	2000	1180	1180	1180	1320	2240	2800	3000	3000	3550	4500	3750	2240	2800	850	1400	2800
	560	3750	4000	3750	3350	2800	2500	2500	3000	3750	3750	3350	3350	3750	4500	5000	3750	2800	1400	1400	2800
	400	3750	4000	4250	3750	3350	3150	3350	3750	4250	4000	3550	3550	4000	4250	4750	4750	2800	1400	1400	2800
1 120 000	800	1250	2000	2120	1180	630	670	750	800	1700	2240	2650	2650	3150	4000	3000	1700	2800	500	1400	2800
	560	3350	3750	3350	2800	2500	2120	2120	2500	3350	3550	3000	3000	3350	4000	4500	3350	2800	1400	1400	2800
	400	3550	3750	3750	3350	3150	2800	3000	3350	4000	3550	3350	3350	3550	4000	4500	4500	2800	1400	1400	2800
1 400 000	560	3000	3350	3000	2650	2120	1900	1800	2120	2800	3150	2800	2800	3150	3750	4000	3000	2800	1400	1400	2800
	400	3350	3550	3550	3150	2800	2650	2650	3000	3750	3350	3000	3000	3350	3750	4250	4000	2800	1400	1400	2800
	280	3350	3550	3750	3550	3350	3150	3150	3350	3750	3350	3150	3150	3350	3750	4000	4000	2800	1400	1400	2800
1 800 000	560	2500	3000	2650	2240	1700	1600	1500	1700	2360	2800	2650	2650	3000	3550	3750	2500	2800	1120	1400	2800
	400	3000	3350	3150	2800	2500	2360	2360	2650	3550	3150	2800	2800	3150	3550	4000	3550	2800	1400	1400	2800
	280	3150	3350	3550	3150	3000	2800	2800	3150	3550	3150	3000	3000	3150	3550	3750	3750	2800	1400	1400	2800
2 240 000	560	2000	2360	2240	2000	1250	1250	1120	1320	2000	2360	2360	2360	2650	3350	3150	2000	2800	850	1400	2800
	400	2800	3150	2800	2500	2240	2000	2000	2360	3000	2800	2650	2500	2800	3350	3750	3150	2800	1400	1400	2800
	280	3000	3150	3150	3000	2650	2500	2650	2800	3350	3000	2800	2800	3000	3350	3550	3550	2800	1400	1400	2800
2 800 000	560	1500	1900	1900	1500	850	900	850	1000	1600	2000	2120	2120	2500	3150	2650	1700	2800	630	1320	2800
	400	2650	2800	2650	2240	2000	1800	1700	2000	2650	2650	2360	2360	2650	3150	3550	2650	2800	1400	1400	2800
	280	2650	3000	3000	2650	2500	2240	2360	2650	3150	2800	2500	2500	2800	3150	3350	3350	2800	1400	1400	2800
3 550 000	400	2360	2650	2360	2000	1800	1500	1500	1800	2360	2500	2120	2120	2500	3000	3150	2360	2800	1180	1400	2800
	280	2500	2800	2800	2500	2240	2120	2120	2360	2800	2500	2360	2360	2500	2800	3150	3150	2800	1400	1400	2800
4 500 000	400	2120	2360	2000	1800	1500	1320	1250	1500	2000	2240	2000	2000	2240	2800	3000	2000	2800	1000	1400	2650
	280	2360	2500	2500	2240	2000	1800	1900	2120	2650	2360	2120	2120	2360	2650	3000	2800	2800	1400	1400	2800
5 600 000	400	1700	2000	1800	1600	1120	1060	1000	1180	1700	2000	1800	1800	2120	2500	2500	1700	2800	800	1400	2500
	280	2120	2360	2240	2000	1800	1600	1600	1900	2500	2240	2000	2000	2240	2500	2800	2500	2800	1400	1400	2650
max		5 000 (3 150 per «piedi corti» - for «short feet»)														2800 1400 1400 2800					

1) An axial load of up to 0.2 times the value in the table is permissible, simultaneously with the radial load and vice versa. If exceeded consult us.
 2) An unfavourable direction of load can limit F_{r2} to $0,9 \cdot F_{r2max}$

Efficiency η :

– gear reducer with 2 gear pairs (2l) 0,96, with 3 gear pairs (3l) 0,94; for $M_2 \ll M_{N2}$, η could considerably decrease; consult us.

Overloads

Where a gear reducer is subjected to high static and dynamic overloads, the need arises for verifying that such overloads will always remain lower than $2 \cdot M_{N2}$ (see ch. 3.5; see ch. 3.7 where $M_{N2} = M_2 \cdot fs$).

Overloads are normally generated when one has:

- starting on full load (especially for high inertias and low transmission ratios), braking, shocks;
- gear reducers in which the low speed shaft becomes driving member due to driven machine inertia;
- applied power higher than that required; other static or dynamic causes.

The following general observations on overloads are accompanied by some formulae for carrying out evaluations in certain typical instances.

Where no evaluation is possible, install safety devices which will keep values within $2 \cdot M_{N2}$.

Starting torque

When starting on full load (especially for high inertias and low transmission ratios) verify that $2 \cdot M_{N2}$ is equal to or greater than starting torque, by using the following formula:

$$M_2 \text{ start} = \left(\frac{M \text{ start}}{M_N} \cdot M_2 \text{ available} - M_2 \text{ required} \right) \frac{J}{J + J_0} + M_2 \text{ required}$$

where:

M_2 required is torque absorbed by the machine through work and frictions;

M_2 available is output torque due to the motor's nominal power;

J_0 is the moment of inertia (of mass) of the motor;

J is the external moment of inertia (of mass) in kg m^2 (gear reducers, couplings, driven machine) referred to the motor shaft;

for other symbols see ch. 2b.

NOTE: when seeking to verify that starting torque is sufficiently high for starting, take into account starting friction, if any, in evaluating M_2 required.

Stopping machines with high kinetic energy (high moments of inertia combined with high speeds) with brake motor

Verify braking stress by means of the formula:

$$\left(\frac{Mf}{\eta} \cdot i + M_2 \text{ required} \right) \frac{J}{J + J_0} - M_2 \text{ required} \leq 2 \cdot M_{N2}$$

where:

Mf is the braking torque setting (see table in ch. 2b); for other symbols see above and ch. 1.

Operation with brake motor

Starting time t_a and revolutions of motor φ_{a_1}

$$t_a = \frac{(J_0 + J) \cdot n_1}{95,5 \left(M \text{ start} - \frac{M_2 \text{ required}}{i} \right)} \text{ [s];} \quad \varphi_{a_1} = \frac{t_a \cdot n_1}{19,1} \text{ [rad]}$$

Braking time t_f and revolutions of motor φ_{f_1}

$$t_f = \frac{(J_0 + J) \cdot n_1}{95,5 \left(Mf + \frac{M_2 \text{ required}}{i} \right)} \text{ [s];} \quad \varphi_{f_1} = \frac{t_f \cdot n_1}{19,1} \text{ [rad]}$$

where:

$M \text{ start}$ [daN m] is motor starting torque $\left(\frac{955 \cdot P_1}{n_1} \cdot \frac{M \text{ start}}{M_N} \right)$ (see ch. 2b);

Mf [daN m] is the braking torque setting of the motor (see ch. 2b);

for other symbols see above and ch. 1.

Assuming a regular air-gap and ambient humidity, and utilizing suitable electrical equipment, repetition of the braking action, as affected by variation in temperature of the brake and by the state of wear of friction surface, is approx $\pm 0,1 \cdot \varphi_{f_1}$.

Duration of friction surface

As a rough guide, the number of applications permissible between successive adjustments of the air-gap is given by the formula:

$$\frac{W \cdot 10^5}{Mf \cdot \varphi_{f_1}}$$

where:

W [MJ] is the work of friction between successive adjustments of the airgap as indicated in the table; for other symbols see above.

The air-gap should measure between 0,25 minimum and 0,6 maximum; as a rule, 5 adjustments can be made.

Grandezza motore Motor size	W MJ
63	10,6
71	14
80	18
90	24
100	24
112	45
132	67
160, 180M	90
180L, 200	125

Low speed shaft angular backlash and torsional stiffness

A rough guide for the angular backlash (high speed shaft being locked) is given in the table. Values vary according to temperature and transmission ratio.

Also the **approx.** values for low speed shaft torsional stiffness — high speed shaft being locked — are given in the table according to the train of gears.

On request it is possible to supply gear reducers with **reduced backlash** (sizes 32 ... 41 excluded) lower than or equal to the minimum values stated on the table.

1) At the distance of 1 m from the low speed shaft centre, angular backlash in mm is obtained by multiplying the value stated in the table by 1 000 (1 rad = 3438').

Grandezza riduttore Gear reducer size	Gioco angolare [rad] ¹⁾ Angular backlash [rad] ¹⁾		Rigidezza torsionale [N m/'] Torsional stiffness [N m/']	
	min	max	R, MR 2I	R, MR 3I
32	0,0050	0,0100	1,6	0,9
40	0,0045	0,0090	3,15	1,8
41	0,0045	0,0090	3,55	2
50	0,0036	0,0071	7,5	4,3
51	0,0036	0,0071	8,5	4,8
63	0,0032	0,0063	15	8,5
64	0,0032	0,0063	17	9,5
80	0,0028	0,0056	30	17
81	0,0028	0,0056	33,5	19
100	0,0023	0,0050	60	33,5
101	0,0025	0,0050	67	37,5
125	0,0022	0,0044	118	67
126	0,0022	0,0044	132	75
140	0,0022	0,0044	150	85
160	0,0020	0,0040	236	132
180	0,0020	0,0040	335	190

Gear reducers input face

The input face of gear reducers (size ≥ 50) has a flange with tapped holes and «hole» centering for eventual fitting of motor support, etc. The use of threaded holes closed with dowel, if any, requires the removal of dowel (avoiding eventual oil loss) and the readjustment of sealant.

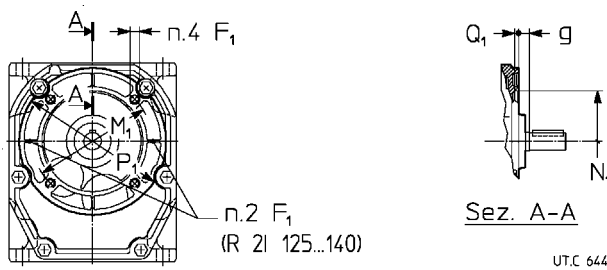

Grand. riduttore Gear reducer size	F ₁	g	M ₁ ∅	N ₁ ∅ H7	P ₁ ∅	Q ₁
50, 51	M 8	9,5	115 ²⁾	95	140	4
63, 64	M 8	10	130	110	160	4,5
80, 81	M 10	10,5	165	130	200	4,5
100, 101	M 12	11	215	180	250	5
125, 126, 140	M 12 ⁶⁾	14 ³⁾	265	230	300	5
160, 180	M 16	19 ³⁾	350	300	400	6

1) Working length of thread 1,05 F₁, 1,5 F₁ for R 2I 125 ... 180.
2) The two upper holes are on a diameter M₁ of 130 mm: consult us.
3) For R 3I g dimension is -4 mm (sizes 125 ... 140), -6 mm (sizes 160 and 180).

Shaft end

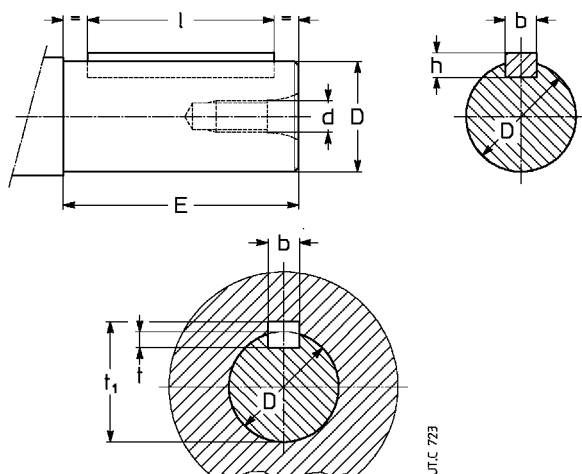

1) I valori tra parentesi sono relativi all'estremità d'albero corta.
1) Values in brackets are for short shaft end.

Estremità d'albero Shaft end			Linguetta Parallel key	Cava Keyway			
D ∅	E ¹⁾	d ∅	b × h × l ¹⁾	b	t	t ₁	
11	j 6	23 (20)	M 5	4 × 4 × 18 (12)	4	2,5	12,7
14	j 6	30	M 6	5 × 5 × 25	5	3	16,2
16	j 6	30	M 6	5 × 5 × 25	5	3	18,2
19	j 6	40	M 6	6 × 6 × 36	6	3,5	21,7
24	j 6	50 (36)	M 8	8 × 7 × 45 (25)	8	4	27,2
28	j 6	60 (42)	M 8	8 × 7 × 45 (36)	8	4	31,2
32	k 6	80 (58)	M 10	10 × 8 × 70 (50)	10	5	35,3
38	k 6	80 (58)	M 10	10 × 8 × 70 (50)	10	5	41,3
42	k 6	110	M 12	12 × 8 × 90	12	5	45,3
45	k 6	82	M 12	14 × 9 × 70	14	5,5	48,8
48	k 6	82 (80)	M 12	14 × 9 × 70	14	5,5	51,8
55	m 6	82	M 12	16 × 10 × 70	16	6	59,3
60	m 6	105	M 16	18 × 11 × 90	18	7	64,4
70	m 6	105	M 16	20 × 12 × 90	20	7,5	74,9
80	m 6	130	M 20	22 × 14 × 110	22	9	85,4
90	m 6	130	M 20	25 × 14 × 110	25	9	95,4
100	m 6	165	M 24	28 × 16 × 140	28	10	106,4

Fixing bolt dimensions for gear reducer feet

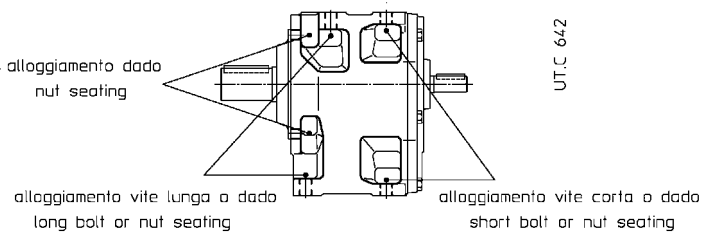

Grandezza riduttore Gear reducer size	Vite corta Short bolt	Vite lunga Long bolt
	UNI 5737-88 (l max)	
50, 51	M 10 × 30	M 10 × 35
63, 64	M 12 × 35	M 12 × 40
80, 81	M 14 × 40	M 14 × 50
100, 101	M 16 × 50	M 16 × 60
125, 126, 140	M 20 × 60	M 20 × 70
160, 180	M 24 × 70	M 24 × 90

Plug position

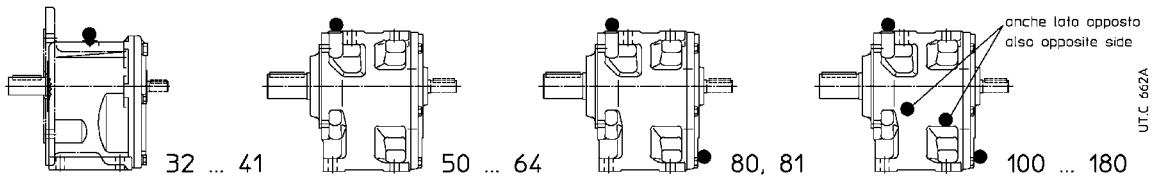

Maximum bending moment of flange MR

In case of assembly of motors supplied by the customer, verify that the static bending moment M_b generated by motor weight on the counter flange of gear reducer is lower than the value allowed M_{bmax} , stated in the table:

$$M_b \leq M_{bmax}$$

where:

$$M_b = G \cdot (X + HF) / 1000 \text{ [daN m]}$$

G [daN] motor weight; numerically nearly equal to motor mass, expressed in kg

X [mm] distance from motor center of gravity from flange surface

HF [mm] given in the table, according to gear reducer size and flange diameter P_1 .

Very long and thin motors, though with bending moments within the prescribed limits, may generate anomalous vibrations during the operation. In these cases it is necessary to foresee a proper additional motor support (see motor specific documentation).

Loads higher than permissible loads may be present in dynamical applications where the gearmotor is subjected to translations, rotations or oscillations: consult us for the study of every specific case

Max allowable bending moment M_{bmax} and HF dimension

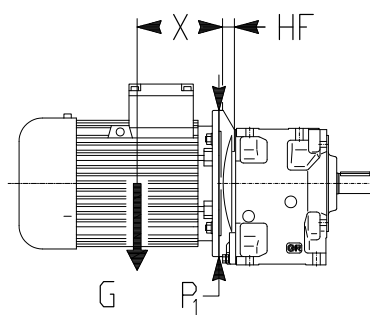

Grandezza riduttore Gear reducer size	P_1 Ø	2I		3I	
		HF mm	M_{bmax} daN m	HF mm	M_{bmax} daN m
32	140	11	14	11	14
40, 41	140	12	25	13,5	25
	160	12	25	13,5	25
50, 51	140	—	—	16	28
	160	16	28	16	28
	200	16	40	16	40
63, 64	160	—	—	19	50
	200	19	50	19	50
	250	19	90	—	—
80, 81	200	22	112	22	112
	250	22	112	22	112
	300	24,5	160	—	—
	350	40	140	—	—
100, 101	200	—	—	24	140
	250	24	140	24	140
	300	24	140	24	140
	350	40	140	—	—
	—	—	—	—	—
125 ... 140	250	—	—	28,5	250
	300	28,5	250	28,5	250
	350	28,5	250	28,5	250
	400	30	250	—	—
	450	52,5	315	—	—
160, 180	300	—	—	34	560
	350	34	560	34	560
	400	34	560	34	560
	450	36	560	36	560
	550	48	560	—	—

4

Installation and maintenance





Section content

4.1	General	84
4.2	Lubrication	85
4.3	Motor replacement	86
4.4	Systems of motor-gear reducer mounting	87

4.1 - General

Be sure that the structure on which gear reducer or gearmotor is fitted is plane, levelled and sufficiently dimensioned in order to assure fitting stability and vibration absence, keeping in mind all transmitted forces due to the masses, to the torque, to the radial and axial loads.

Position the gear reducer or gearmotor so as to allow a free passage of air for cooling both gear reducer and motor (especially at motor fan side).

Avoid: any obstruction to the air-flow; heat sources near the gear reducer that might affect the temperature of cooling-air and of gear reducer for radiation; insufficient air recycle or any other factor hindering the steady dissipation of heat.

Mount the gear reducer so as not to receive vibrations.

When external loads are present use pins or locking blocks, if necessary.

When fitting gear reducer and machine and/or gear reducer and eventual flange **B5** it is recommended to use **locking adhesives** such as LOCTITE on the fastening screws (also on flange mating surfaces).

For outdoor installation or in a hostile environment protect the gear reducer or gearmotor with anticorrosion paint. Added protection may be afforded by water-repellent grease (especially around the rotary seating of seal rings and the accessible zones of shaft end).

Gear reducers and gearmotors should be protected wherever possible, and by whatever appropriate means, from solar radiation and extremes of weather; weather protection **becomes essential** when high or low speed shafts are vertically disposed, or where the motor is installed vertical with fan uppermost.

For ambient temperatures greater than 40 °C or less than 0 °C, consult us.

Before wiring-up the gearmotor, make sure that motor voltage corresponds to input voltage. If the direction of rotation is not as desired, invert two phases at the terminals.

Star-delta starting should be adopted for starting on no load (or with a very small load) and/or when the necessity is for smooth starts, low starting current and limited stresses.

If overloads are imposed for long periods of time, or if shocks or danger of jamming are envisaged, then motor-protections, electronic torque limiters, fluid couplings, safety couplings, control units or other suitable devices should be fitted.

Where duty cycles involve a high number of starts on-load, it is advisable to utilize **thermal probes** (fitted on the wiring) for motor protection; a thermal overload relay is unsuitable since its threshold must be set higher than the motor's nominal current rating.

Use varistors to limit voltage peaks due to contactors.

Warning! Bearing life, good shaft and coupling running depend on alignment precision between the shafts. Carefully align the gear reducer with the motor and the driven machine (with the aid of shims if need be), interposing flexible couplings whenever possible.

Whenever a leakage of lubricant could cause heavy damages, increase the frequency of inspections and/or envisage appropriate control devices (e.g.: remote oil level gauge, lubricant for food industry, etc.).

In polluting surroundings, take suitable precautions against lubricant contamination through seal rings or other.

Gear reducer or gearmotor should not be put into service before it has been incorporated on a machine which is conform to 2006/42/EC directive.

For brake or non-standard motors, consult us for specific information.

Fitting of components to shaft ends

It is recommended that the bore of parts keyed to shaft ends is machined to H7 tolerance; for low speed shaft ends, tolerance must be **K7** when load is not uniform and light. Other details are given in the «Shaft end» table (ch. 3.13).

Before mounting, clean mating surfaces thoroughly and lubricate against seizure and fretting corrosion.

Installing and removal operations should be carried out with **pullers** and **jacking screws** using the tapped hole at the shaft butt-end; for H7/m6 and K7/j6 fits it is advisable that the part to be keyed is pre-heated to a temperature of 80 ÷ 100 °C.

4.2 - Lubrication

Gear pairs and bearings are oil-bath or splash lubricated excluding sizes 32 ... 41 which are grease lubricated.

Sizes 32 ... 41: gear reducers are supplied **filled with synthetic grease** (SHELL Gadus S5, MOBIL SHX Polyrex 005), providing lubrication «for life» – assuming pollution-free surroundings.

Sizes 50 ... 81: gear reducers are supplied **filled with synthetic oil** (KLÜBER Klübersynth GH 6-220, MOBIL Glygoyle 220, SHELL Omala S4 WE 220) providing lubrication «for life» – assuming pollution-free surroundings. Ambient temperature range $0 \div 40$ °C with peaks of -20 °C and +50 °C.

Important verify mounting position keeping in mind that if gear reducer is installed in a mounting position which differs from the one indicated on the name plate, it could require the addition of the difference between the two quantities of lubricant given in ch. 3.6 and 3.8, by way of the housing filler hole.

Sizes 100 ... 180: gear reducers are supplied **without oil**; before putting into service, fill to the specified level with **mineral oil** having the ISO viscosity grade given in the table.

1) Lubricant quantities stated on ch. 3.6 and 3.8 are approximate for provisioning. The exact oil quantity the gear reducer is to be filled with is definitely given by the level.

When it is required to increase oil change interval («long life»), the ambient temperature range, and/or reduce oil temperature, use **synthetic oil** with polyalphaolefines basis (PAO), always suggested, or with polyglycol basis (PAG) having ISO viscosity grade as indicated in the table.

Manufacturer	PAO synthetic oil	PAG synthetic oil	Mineral Oil
AGIP	Blasia SX	Blasia S	Blasia
ARAL	Degol PAS	Degol GS	Degol BG
BP	Enersyn EPX	Enersyn SG-XP	Energol GR XP
CASTROL	Alphasyn EP	Optiflex A	Alpha SP
FUCHS	Renolin Unisys	Renolin PG	CLP Renolin CLP
KLÜBER	Klübersynth GEM4	Klübersynth GH6	Klüberoil GEM1
MOBIL	Mobil SHC Gear	Mobil Glygoyle	Mobilgear 600 XP
SHELL	Omala S4 GX	Omala S4 WE	Omala S2 G
TEXACO	Pinnacle	Synlube CLP	Meropa
TOTAL	Carter SH	Carter SY	Carter EP

ISO viscosity grade

Mean kinematic viscosity [cSt] at 40 °C.

Speed n_2 min ⁻¹	Ambient temperature ²⁾ [°C]		
	mineral oil		synthetic oil
	0 ÷ 20	10 ÷ 40	0 ÷ 40
> 224	150	150	150
224 ÷ 22,4	150	220	220
22,4 ÷ 5,6	220	320	320
< 5,6	320	460	460

2) Peaks of 10 °C above and 10 °C (20 °C for synthetic oil) below the ambient temperature range are acceptable.

An overall guide to **oil-change interval** is given in the table, and assumes pollution-free surroundings. Where heavy overloads are present, halve the values.

Oil temperature [°C]	Oil-change interval [h]	
	mineral oil	synthetic oil
≤ 65	8 000	25 000
65 ÷ 80	4 000	18 000
80 ÷ 95	2 000	12 500

Combined gear reducer and gearmotor units: lubrication remains independent, thus data relative to each single gear reducer hold good.

Seal rings: duration depends on several factors such as dragging speed, temperature, ambient conditions, etc.; as a rough guide; it can vary from 3 150 to 12 500 h.

Warning: for gear reducers sizes 100 ... 180, before unscrewing the filler plug with valve (symbol ) wait until the unit has cooled and then open with caution.

4.3 - Motor replacement

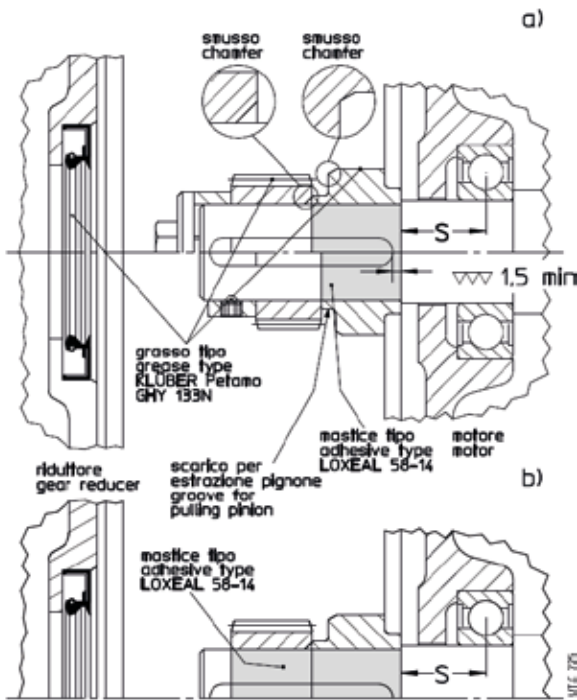

Motor size	Min dynamic load capacity [daN]		Max dimension 'S' mm
	Front	Rear	
63	450	335	16
71	630	475	18
80	900	670	20
90	1 320	1 000	22,5
100	2 000	1 500	25
112	2 500	1 900	28
132	3 550	2 650	33,5
160	4 750	3 350	37,5
180	6 300	4 500	40
200	8 000	5 600	45
225	10 000	7 100	47,5
250	12 500	9 000	53
280	16 000	11 200	56

As all gearmotors are fitted with **standard** motors, motor replacement is extremely easy. Simply observe the following instructions:

- be sure that the mating surfaces are machined under accuracy rating (IEC 60072-1);
- clean surfaces to be fitted thoroughly;
- check that the fit-tolerance (push-fit) between hole and shaft end is K6/j6 for $D \leq 28$ mm, J6/k6 for $D \geq 38$ mm;
- in the event of a lowered keyway, replace the motor keyway with the one supplied with the gear reducer; adjust the keyway length to the motor shaft, if need be.; check that between the top and the bottom of the hole keyway there is a backlash of $0,1 \div 0,2$ mm; in the event of output shaft keyway, lock the key by pins;
- make sure that the motors have bearing location and overhang (distance S) as shown in the table;
- make sure that the motors have bearing location and overhang (distance S) as shown in the table;
- assemble on motor shaft, as follows:
 - the **spacer** pre-heated at **65 °C** sealing the motor shaft part with **locking adhesive type LOXEAL 58-14** and ensuring that between keyway and motor shaft shoulder there is a ground helical section of at least 1,5 mm; pay attention **not to damage the external surface** of spacer;
 - **the key** in the keyway, taking care that a brief segment of at least 0,9 times the pinion width;
 - the pinion pre-heated at **80 ÷ 100 °C**;
 - **the axial fastening system** where foreseen (head self-locking screw with base, spacer, or hub clamp with one or more dowels, fig. a); for the cases foreseen **without axial fastening** (fig. b), seal with **locking adhesive type LOXEAL 58-14** also the motor shaft section below the **pinion**;
- in the event of axial fastening system with hub clamp and dowels, be sure that these ones do not overhang from spacer external surface: screw the dowel and matrix the motor shaft with a tip;
- grease the pinion teeth, the sealing ring rotary seat and the seal ring (with KLÜBER Petamo GHY 133N), and assemble carefully, **paying attention not to damage the seal ring lip due to accidental shock with the pinion toothings.**

4.4 - Systems of motor-gear reducer mounting

S

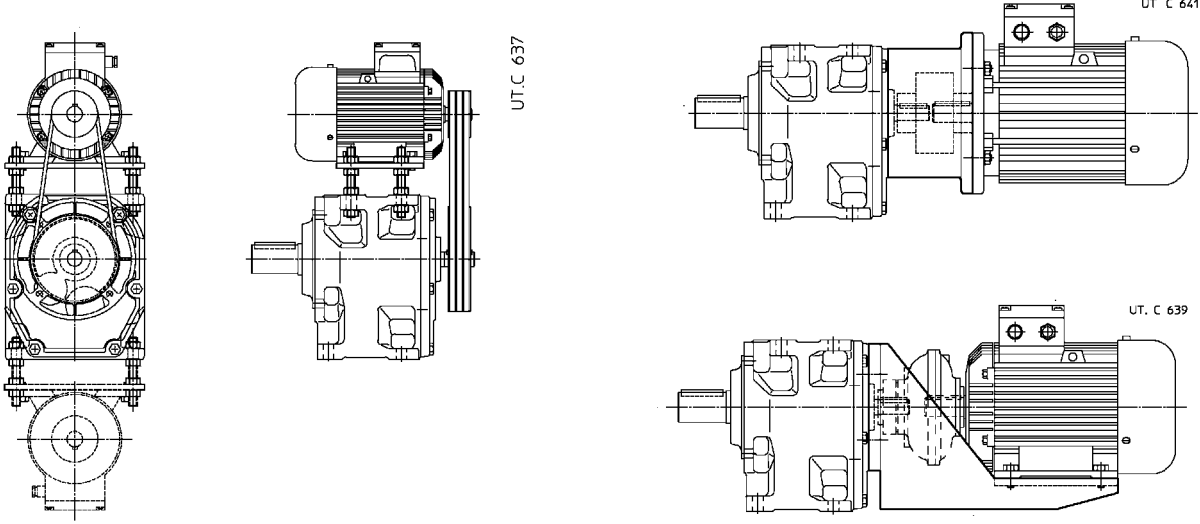

Accessories and non-standard designs





Section content

5.1	Strengthened high speed shaft bearings	90
5.2	Non-standard low speed shaft end	90
5.3	Oversized B5 flange (low speed shaft)	90
5.4	Design for agitators and aerators	91
5.5	Gear reducer design ATEX II 2GD and 3 GD	91
	Miscellaneous	93

5.1 - Strengthened high speed shaft bearings

Gear reducer R 2I sizes 50, 63, 80 and sizes 51, 64, 81 with $i_N \geq 16$ and R 3I sizes 63 ... 101 can be supplied with cylindrical roller bearings on high speed shaft so as to allow high radial loads, values **x 1,6** (ch. 13); this design is standard for all remaining gear reducers, which present cylindrical roller or taper roller bearings as a standard.

Supplementary description when ordering by **designation: strengthened high speed shaft bearings.**

5.2 - Non-standard low speed shaft end

The gear reducers and gearmotors size 40 ... 101 can be supplied with non-standard low speed shaft end; dimensions as per following table.

Gear reducer size	D Ø	E	d Ø	Keyway b x h x l
40 ¹⁾	20 g6	40	M6	6 x 6 x 36
41	20 j6	36	M6	6 x 6 x 25
50	25 j6	50	M8	8 x 7 x 45
51	25 j6	42	M8	8 x 7 x 36
63, 64	30 k6	58	M10	8 x 7 x 45
63 ¹⁾	35 g6	58	M10	10 x 8 x 50
64	35 k6	58	M10	10 x 8 x 50
80 ¹⁾	40 g6	80	M12	12 x 8 x 70
81	40 k6	80	M12	12 x 8 x 70
100 ¹⁾	50 g6	82	M12	14 x 9 x 70
101	50 k6	82	M12	14 x 9 x 70

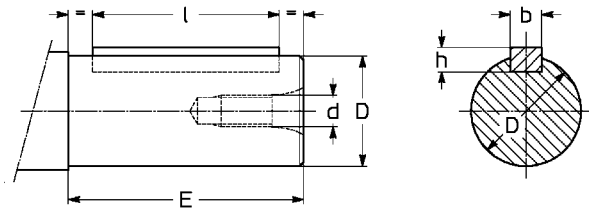

1) Shaft end without shoulder.

Supplementary description when ordering by **designation: nonstandard low speed shaft end, D ...** (dimension D Ø).

5.3 - Oversized B5 flange (low speed shaft)

All gear reducers and gearmotors (sizes ≥ 50) can be supplied with oversized B5 flange (always having through holes) supplied separately (complete with stud bolts) or fitted on standard B5 flange – if indicated when ordering –. Flange plane coincides with low speed shaft end shoulder.

The gear reducer is to be fastened after having fastened the flange on the machine.

Locking adhesives such as LOCTITE, should be used both on screws and coupling surfaces.

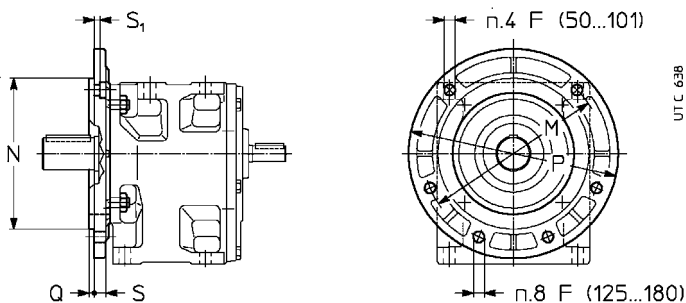

Gear reducer size	F Ø	M Ø	N Ø h6	P Ø	Q	S	S ₁ 1)
50, 51	10,5	165	130	200	3,5	12	5,5
63, 64	13	215	180	250	4	14	6,5
80, 81	13	265	230	300	4	15	9
100, 101	17	300	250	350	5	17	10,5
125, 126, 140	17 ^b	400	350	450	5	17	—
160, 180	17 ^b	500	450	550	5	20	—

1) Screw type UNI 5931-84

Supplementary description when ordering by **designation: oversized B5 flange.**

5.4 - Design for agitators and aerators

This design has been specifically developed for aerators and agitators.

In addition to the rigid and precise **single-piece** housing, **universal** mounting, taper roller bearings (sizes 125 ... 180), the main features of this **reliable compact and economic** design are:

- extended bearing housing to improve radial and axial load ratings (sizes ≥ 125 : taper roller bearings) and to reduce overhangs;
- plentiful low speed shaft end diameter;
- double seals on the low speed shaft with chromium plated raceway;
- space between double seals packed with grease and top hat arrangement which acts as water splash guard for aerators;
- **oil** lubricated bearing on low speed shaft end side; additional stainless steel drain plug to facilitate complete oil drainage; all this ensures **total reliability** (gear pairs and bearings) during running and **minimum maintenance**;
- special single compound paint: antirust zinc primer plus blue RAL 5010 DIN 1843 synthetic paint.

Options:

- drip proof cover for motor (standard protection IP 55);
- special dual compound paint;
- remote oil level and/or oil temperature indicator with threshold signal (sizes ≥ 160).
- oversized B5 flange.

Axial load F_{a2} on low speed shaft end can be doubled according to direction of rotation for combinations **2** (as shown in the ch. 3.12 and in table) which are to be **preferred**; (for sizes 81 and 101 consult us for values of F_{a2}).

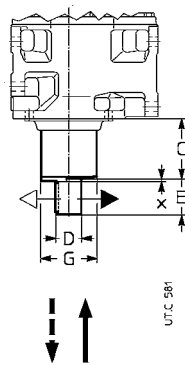

Gear reducer size	C	D Ø	E	G Ø	x = 1)	Axial load F_{a2}			
						←	↑	↓	→
80, 81	112	45 k6	82	104	—	1	2	2	1
100, 101	137	55 m6	82	126	—	2	1	1	2
125, 126	139	70 m6	105	140	3	1	2	2	1
140	140	80 m6	130	159	3	1	2	2	1
160	168	90 m6	130	183	4	2	1	1	2
180	158	100 m6	165	226	4	2	1	1	2

1) Thickness of protection disc.

Supplementary description when ordering by **designation: design for agitators**.

5.5 Gear reducer design ATEX II 2 GD and 3 GD

Coaxial gear reducers and gearmotors (sizes 32 ... 41 excluding) may be supplied according to European Community Directive ATEX 2014/34/EU in order to be used in potentially explosive atmospheres:

- category **2 GD** (for operation in zones 1 (G = gas), 21 (D = dust); **probable** presence of explosive atmosphere) and **3 GD** (for operation in zones 2 (gas), 22 (dust): **improbable** presence of explosive atmosphere) - with surface temperature $T \leq 135^\circ\text{C}$ (T4).

These are the main variations of the product:

- fluoro-rubber seal rings;
- metal plugs; filler plug with filter and valve;
- special name plate with ATEX mark and indication of application limits.
- external protection tested on a water-soluble dual-compound polyurethane **conductive** enamel, **color grey** RAL 7040, corrosivity class C3 ISO 12944-2;
- «ATEX instructions» manual.

For category 2 GD, depending on **minimum control intervals**, also:

- 2 GD monthly control
- double seal rings on low speed shaft;
- 2 GD quarterly control (size 100 ... 180)
- double seal rings on low speed shaft;
- oil temperature probe;
- bearing temperature probe, if any;

this solution is advisable when the gear reducer has difficult acces or when a decrease in control frequency is required.

Operating ambient temperature: $-20 \pm +40^\circ\text{C}$.

The «**ATEX operating instructions**» (with the additional documentation, if any) are **integral part of the supply** of each gear reducer; every indication stated in it must be carefully applied. In case of needs, consult us.

Gear reducer size selection

Determine the size of gear reducer as indicated in ch. 5 considering following additional limitations:

- maximum input speed $n_1 \leq 1\,500 \text{ min}^{-1}$;
- **service factor requested** determined according to ch. 3.4 increased with the factors stated in following table - **never lower than 1**.

Verify, at last, that the applied power P_1 is lower than or equal to nominal thermal power P_{tn} multiplied by thermal factors $f_{t2} \dots f_{t5}$ (see ch 4) and by corrective factor f_{ATEX} given in the following table.

ATEX design **corrective factors** for required service factor f_s and nominal thermal power P_{tn} .

Categoria ATEX - ATEX Category	f_{sATEX}	f_{ATEX}
2 GD	1,18	0,8
3 GD	1,06	0,9

Motor category selection

In the table on the right the minimum features of motors to be installed with Rossi gear reducers in ATEX design, in potentially explosive atmosphere areas.

Protection methods of electric tools:

- EEEx **e** increased safety;
- EEEx **d** flameproof enclosure;
- EEEx **de** combination of «d» and «e»;
- EEEx **nA** reduced sparking

Zona Zone	Riduttore Rossi in esecuzione ATEX II Rossi Gear reducer ATEX II design	Categoria motore richiesta ¹⁾ Required motor category ¹⁾
1	2 GD	2 G EEEx e 2 G EEEx d 2 G EEEx de con termistori o Pt100
21		2 D IP65
1, 21		2 GD EEEx e 2 GD EEEx d 2 GD EEEx de with thermistors or Pt100
2	3 GD	3 G EEEx nA –
22		3 D IP54 ²⁾ –
2, 22		3 GD EEEx nA

1) The devices suitable for zone 1 are also suitable for zone 2, similarly the devices suitable for zone 21 are also suitable for zone 22.

2) For conductive dusts motor must be 2 D IP65.

Supplementary description when ordering by **designation**¹⁾:
design ATEX II ...

- ... **3 GD T4** sizes 50 ... 180
- ... **2 GD T4 monthly control** sizes 50 ... 180
- ... **2 GD T4 quarterly control** sizes 100 ... 180

1) For gearmotors, this designation refers to the only **gear reducer part**.

Miscellaneous

- Gearmotors with:
 - **brake motor** (also single-phase) with d.c. **safety and/or parking brake** (sizes 63 ... 132) having overall dimensions nearly the same of a standard motor and braking torque $M_f \geq M_N$, maximum economy; **suitable for running with inverter**, non-standard designs with axial independent cooling fan and/or encoder (see ch. 2b);
 - **two-speed motor** (standard, brake motor, brake motor with safety brake and/or parking brake, with flywheel) with 2.4, 2.6, 2.8, 2.12, 4.6, 4.8, 6.8 poles;

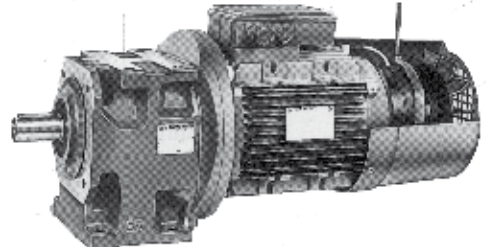
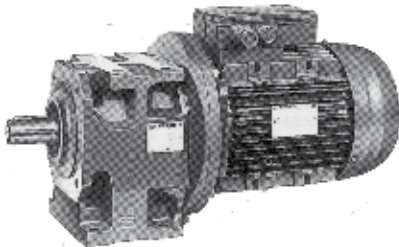

- motor featuring: d.c. supply; single-phase; explosion-proof; with second shaft end; with non-standard protection, voltage and frequency; provided with devices against overloads and overheating;
- **motor without fan** externally cooled **by natural convection** (sizes 63 ... 112); design for textile industry.

– **MLA unit, mechanical torque limiter on input shaft**, motor sizes **80 ... 200**.

Mechanical torque limiter unit to be interposed between gear reducer and B5 mounting position motor standardized to IEC (or wide belt or planetary motor-variator) or, in **combined units**, between the initial gear reducer and the final gear reducer.

Axially ultra-compact design: excellent load bearing with life lubricated double row angular contact ball bearings (motor size ≤ 112) or «O» disposed taper roller bearings.

The unit protects the drive from accidental overloads by excluding inertia loads transmitted from up-line masses and down-line masses.

LA unit is friction type (friction surfaces without asbestos). When the transmitted torque tends to exceed the setting, the drive «slips» although **it remains** engaged and transmits torque equal to the limiter setting value; slipping stops as soon as the load returns to normal; in the case of very brief overloads the driven machine will continue normal operation (after decelerating or stopping) without requiring reset procedures.

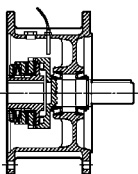

MLA
friction

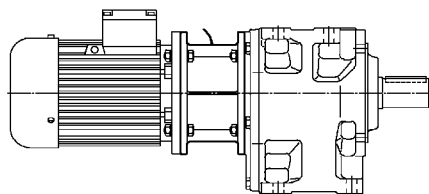

MLA
mounted between gear reducer
and motor or motor-variator

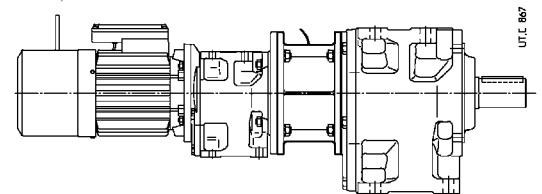

MLA
mounted onto combined units

* on request

- Gearmotors with interposed compact clutch-brake or fluid coupling/brake unit.
- Semi-flexible low speed shaft couplings.
- Special paint options:
 - **external, single-compound:** antirust zinc primer plus blue RAL 5010 DIN 1843 synthetic paint (excluding 32 ... 41);
 - **external, dual-compound:** dual-compound epoxy-polyamidic antirust primer plus dual-compound blue RAL 5010 DIN 1843 polyurethane enamel;
 - **internal, dual-compound:** unaffected by polyglycol synthetic oils (sizes 100 ... 180).
- Special seal rings; double seal.

blank page

Technical formulae





Main formulae concerning mechanical drives, according to the Technical System and International Unit System (SI).

Size	Con unità Sistema Tecnico With Technical System units	Con unità SI With SI units
starting or stopping time as a function of an acceleration or deceleration, of a starting or braking torque	$t = \frac{Gd^2 \cdot n}{375 \cdot M} [s]$	$t = \frac{J \cdot \omega}{M} [s]$
velocity in rotary motion	$v = \frac{\pi \cdot d \cdot n}{60} = \frac{d \cdot n}{19,1} [m/s]$	$v = \omega \cdot r [m/s]$
speed n and angular velocity ω	$n = \frac{60 \cdot v}{\pi \cdot d} = \frac{19,1 \cdot v}{d} [min^{-1}]$	$\omega = \frac{v}{r} [rad/s]$
acceleration or deceleration as a function of starting or stopping time		$a = \frac{v}{t} [m/s^2]$
angular acceleration or deceleration as a function of a starting or stopping time, of a starting or braking torque	$\alpha = \frac{n}{9,55 \cdot t} [rad/s^2]$ $\alpha = \frac{39,2 \cdot M}{Gd^2} [rad/s^2]$	$\alpha = \frac{\omega}{t} [rad/s^2]$ $\alpha = \frac{M}{J} [rad/s^2]$
starting or stopping distance as a function of an acceleration or deceleration, of a final or initial velocity		$s = \frac{a \cdot t^2}{2} [m]$ $s = \frac{v \cdot t}{2} [m]$
starting or stopping angle as a function of an angular acceleration or deceleration, of a final or initial angular velocity	$\varphi = \frac{n \cdot t}{19,1} [rad]$	$\varphi = \frac{\omega \cdot t}{2} [rad]$
mass	$m = \frac{G}{g} [\frac{kgf \cdot s^2}{m}]$	m è l'unità di massa [kg] m is the unit of mass [kg]
weight (weight force)	G è l'unità di peso (forza peso) [kgf] $G = m \cdot g [N]$ G is the unit of weight (weight force) [kgf]	
force in vertical (lifting), horizontal, inclined motion of translation (μ = coefficient of friction; φ = angle of inclination)	$F = G [kgf]$ $F = \mu \cdot G [kgf]$ $F = G (\mu \cdot \cos \varphi + \sin \varphi) [kgf]$	$F = m \cdot g [N]$ $F = \mu \cdot m \cdot g [N]$ $F = m \cdot g (\mu \cdot \cos \varphi + \sin \varphi) [N]$
dynamic moment Gd², moment of inertia J due to a motion of translation (numerically $J = \frac{Gd^2}{4}$)	$Gd^2 = \frac{365 \cdot G \cdot v^2}{n^2} [kgf \cdot m^2]$	$J = \frac{m \cdot v^2}{\omega^2} [kg \cdot m^2]$
torque as a function of a force, of a dynamic moment or of a moment of inertia, of a power	$M = \frac{F \cdot d}{2} [kgf \cdot m]$ $M = \frac{Gd^2 \cdot n}{375 \cdot t} [kgf \cdot m]$ $M = \frac{716 \cdot P}{n} [kgf \cdot m]$	$M = F \cdot r [N \cdot m]$ $M = \frac{J \cdot \omega}{t} [N \cdot m]$ $M = \frac{P}{\omega} [N \cdot m]$
work, energy in motion of translation, in rotary motion	$W = \frac{G \cdot v^2}{19,6} [kgf \cdot m]$ $W = \frac{Gd^2 \cdot n^2}{7160} [kgf \cdot m]$	$W = \frac{m \cdot v^2}{2} [J]$ $W = \frac{J \cdot \omega^2}{2} [J]$
power in motion of translation, in rotary motion	$P = \frac{F \cdot v}{75} [CV]$ $P = \frac{M \cdot n}{716} [CV]$	$P = F \cdot v [W]$ $P = M \cdot \omega [W]$
power available at the shaft of a single-phase motor ($\cos \varphi$ = power factor)	$P = \frac{U \cdot I \cdot \eta \cdot \cos \varphi}{736} [CV]$	$P = U \cdot I \cdot \eta \cdot \cos \varphi [W]$
power available at the shaft of a three-phase motor	$P = \frac{U \cdot I \cdot \eta \cdot \cos \varphi}{425} [CV]$	$P = 1,73 \cdot U \cdot I \cdot \eta \cdot \cos \varphi [W]$

Note. Acceleration or deceleration are understood constant; motion of translation and rotary motion are understood rectilinear and circular respectively.

Rossi S.p.A.
Via Emilia Ovest 915/A
41123 Modena - Italy

info@rossi.com
www.rossi.com

2611.CATE-22.11-0-EN

© Rossi S.p.A. Rossi reserves the right to make any modification whenever to this publication contents. The information given in this document only contains general descriptions and/or performance features which may not always specifically reflect those described.

The Customer is responsible for the correct selection and application of product in view of its industrial and/or commercial needs, unless the use has been recommended by technical qualified personnel of Rossi, who were duly informed about Customer's application purposes. In this case all the necessary data required for the selection shall be communicated exactly and in writing by the Customer, stated in the order and confirmed by Rossi. The Customer is always responsible for the safety of product applications. Every care has been taken in the drawing up of the catalog to ensure the accuracy of the information contained in this publication, however Rossi can accept no responsibility for any errors, omissions or outdated data. Due to the constant evolution of the state of the art, Rossi reserves the right to make any modification whenever to this publication contents. The responsibility for the product selection is of the Customer, excluding different agreements duly legalized in writing and undersigned by the Parties.